

French Dr., Hobbs, NM 88240  
 District II  
 1301 W. Grand Avenue, Artesia, NM 88210  
 District III  
 1000 Rio Brazos Road, Aztec, NM 87410  
 District IV  
 1220 S. St. Francis Dr., Santa Fe, NM 87505

State of New Mexico  
 Energy Minerals and Natural Resources

Form C-101  
 May 27, 2004

Oil Conservation Division  
 1220 South St. Francis Dr.  
 Santa Fe, NM 87505

RECEIVED

Submit to appropriate District Office

JUL 20 2005

AMENDED REPORT

OCD-ARTEZIA

APPLICATION FOR PERMIT TO DRILL, RE-ENTER, DEEPEN, PLUGBACK, OR ADD A ZONE

Operator Name and Address Mewbourne Oil Company Po Box 5270 Hobbs, NM 88240		OGRID Number 14744
Property Code 34969		API Number 30-015-34230
Property Name Pecos River 20		Well No. 1
Proposed Pool 1 South Carlsbad Morrow	73960	Proposed Pool 2

Surface Location

UL or lot no. P	Section	Township	Range	Lot Idn	Feet from the	North/South line	Feet from the	East/West line	County
	20	22S	27E		868	S	990	E	Eddy

Proposed Bottom Hole Location If Different From Surface

UL or lot no.	Section	Township	Range	Lot Idn	Feet from the	North/South line	Feet from the	East/West line	County
---------------	---------	----------	-------	---------	---------------	------------------	---------------	----------------	--------

Additional Well Information

Work Type Code N	Well Type Code G	Cable/Rotary R	Lease Type Code P	Ground Level Elevation 3128'
Multiple No	Proposed Depth 12100	Formation Morrow	Contractor TBA	Spud Date ASAP
Depth to Groundwater 50' or more but less than 100 yes = 20 pts		Distance from nearest fresh water well Less than 1000 from all other wtr sources .20 pts		Distance from nearest surface water 1000' or more 10 pts
Pit: Liner: Synthetic <input checked="" type="checkbox"/> _____ mils thick Clay <input type="checkbox"/>		Pit Volume: 24000 bbls		Drilling Method: Production
Closed-Loop System <input type="checkbox"/>		Fresh Water <input checked="" type="checkbox"/> Brine <input checked="" type="checkbox"/> Diesel/Oil-based <input type="checkbox"/> Gas/Air <input type="checkbox"/>		

Proposed Casing and Cement Program

Hole Size	Casing Size	Casing weight/foot	Setting Depth	Sacks of Cement	Estimated TOC
17 1/2"	13 3/8"	48#	400'	400	Surface
12 1/4"	9 5/8"	40#	2100'	1000	Surface
8 3/4"	7"	26#	8900'	1500	Tie Back
6 1/8"	5"	18#	12200'	500	Tie Back

Describe the proposed program. If this application is to DEEPEN or PLUG BACK, give the data on the present productive zone and proposed new productive zone. Describe the blowout prevention program, if any. Use additional sheets if necessary.

BOP Program: 13 3/4" 2k Hydril (see Exhibit #2) from surface casing to intermediate TD. Schaffer LWS or equivalent (Double-Ram Hydraulic) 11" 5000# with Hydril. (See Exhibit #2A) from surface casing to total depth. Rotating head, PVT, flow monitors and mud gas Separator from the Wolfcamp to TD.

Mud Program:

- 0' to 400' Fresh Water, spud mud, lime for PH and LCM as needed for seepage.
- 400' to 2100' Brine Water, lime for PH and LCM as needed for seepage.
- 2100' to 8900' Fresh Water, lime for PH and LCM as needed for seepage.
- 8900' to TD Cut brine. 9.3 #/g, Caustic for PH, Starch for WL control and LCM as needed for seepage

**AS A CONDITION OF APPROVAL, A DETAILED CLOSURE PLAN MUST BE APPROVED BEFORE CLOSURE MAY COMMENCE.**

City of Carlsbad Permit required to spud.

I hereby certify that the information given above is true and complete to the best of my knowledge and belief. I further certify that the drilling pit will be constructed according to NMOCD guidelines  a general permit , or an (attached) alternative OCD-approved plan .

OIL CONSERVATION DIVISION

Approved by: *Jim W. Brown*  
 District II Supervisor

Title:

Approval Date: JUL 26 2005 Expiration Date: JUL 26 2006

Printed name: Kristi Green *Kristi Green*

Title: Hobbs Production

E-mail Address:

Date: 07/19/05

**As a condition of approval, if during pit construction water is encountered or if water seeps in pits after construction the OCD MUST BE CONTACTED IMMEDIATELY!**

Conditions of Approval Attached

**NOTIFY OCD OF SPUD & TIME TO WITNESS CEMENTING OF SURFACE CASING**

79.5 S.C.I.T

DISTRICT III  
1000 Rio Brazos Rd., Aztec, NM 87410  
DISTRICT IV  
2040 South Pacheco, Santa Fe, NM 87505

OIL CONSERVATION DIVISION  
P.O. Box 2088  
Santa Fe, New Mexico 87504-2088

AMENDED REPORT

WELL LOCATION AND ACREAGE DEDICATION PLAT

API Number	Pool Code	Pool Name South Carlsbad Morrow
Property Code	Property Name PECOS RIVER "20"	Well Number 81
OGRID No. 14744	Operator Name MEWBOURNE OIL COMPANY	Elevation 3128

Surface Location

UL or lot No.	Section	Township	Range	Lot Idn	Feet from the	North/South line	Feet from the	East/West line	County
P	20	22S	27E		868	SOUTH	990	EAST	EDDY

Bottom Hole Location If Different From Surface

UL or lot No.	Section	Township	Range	Lot Idn	Feet from the	North/South line	Feet from the	East/West line	County

Dedicated Acres 320	Joint or infill	Consolidation Code	Order No.
------------------------	-----------------	--------------------	-----------

NO ALLOWABLE WILL BE ASSIGNED TO THIS COMPLETION UNTIL ALL INTERESTS HAVE BEEN CONSOLIDATED OR A NON-STANDARD UNIT HAS BEEN APPROVED BY THE DIVISION

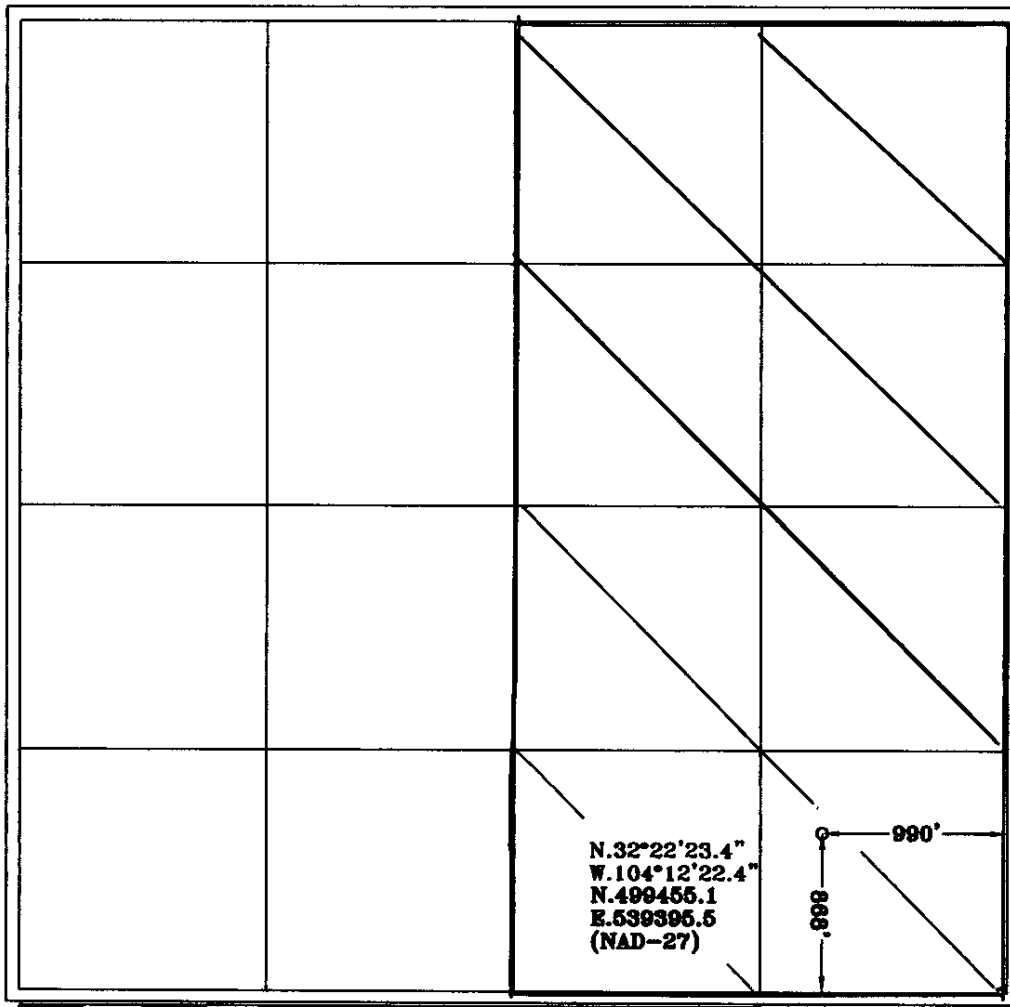

**OPERATOR CERTIFICATION**

I hereby certify that the information contained herein is true and complete to the best of my knowledge and belief.

*Kristi Green*  
Signature  
Kristi Green  
Printed Name  
Hobbs Regulatory  
Title  
06/22/05  
Date

---

**SURVEYOR CERTIFICATION**

I hereby certify that the well location shown on this plat was plotted from field notes of actual surveys made by me or under my supervision, and that the same is true and correct to the best of my belief.

6/07/2005  
Date Surveyed

Signature & Seal of Professional Surveyor  
  
 Certificate No. Herschel L. Jones RLS 3640  
 PECOS RIVER 20  
 GENERAL SURVEYING COMPANY

0 330' 660' 990' 1650' 1980' 2310' 2310' 1980' 1650' 990' 660' 330' 0'

## MULTI-POINT SURFACE USE AND OPERATIONS PLAN

### MEWBOURNE OIL COMPANY

Pecos River 20 #1  
868' FSL & 990' FEL  
Section 20-T22S-R27E  
Eddy County, New Mexico

This plan is submitted with Form 3160-3, Application for Permit to Drill, Covering the above described well. The purpose of this plan is to describe the location of the proposed well, the proposed construction activities and operations plan, the magnitude of the surface disturbance involved, and the procedures to be followed in restoring the surface so that a complete appraisal can be made of the environmental impact associated with the proposed operations.

#### 1. Existing Roads:

- A. Exhibit #3 is a road map showing the location of the proposed well. Exhibit #3A is a topographic map showing the location of the proposed well and access road. Existing roads are highlighted in red and proposed roads are highlighted in yellow.
- B. **Directions to location from Carlsbad, NM: South on Canal street to Old Caverns Hwy and turn left. Continue east then road will turn south. Continue approx 1 mile to Elgin Road and turn left. Continue east 0.75 miles to new location.**

#### 2. Proposed Access Road:

- A. Will need 1500' of new road.
- B. The access to the location will be limited to 16' in width and will adequately drain runoff and control erosion as presently constructed.

#### 3. Location of Existing and/or Proposed Facilities:

- A. There are no production facilities on this lease at the present time.
- B. In the event that the well is productive, production facilities will be located on the well pad.
- C. All production vessels left on location will be painted to conform with BLM painting stipulations within 180 days of installation.

#### 4. Location and Type of Water Supply

The well will be drilled with a combination of fresh water and brine water based mud systems. The water will be obtained from commercial suppliers in the area and/or hauled to the location by transport trucks over existing and proposed roads as indicated in Exhibit #3.

#### 5. Source of Construction Materials

All material required for construction of the drill pad and access roads will be obtained from private, state, or federal pits. The construction contractor will be solely responsible for securing construction materials required for this operation and paying any royalties that may be required on those materials.

**6. Methods of Handling Waste Disposal:**

- A. Drill cuttings not retained for evaluation purposed will be disposed of in the reserve pit.
- B. Drilling fluids will be allowed to evaporate in the reserve pit prior to closure.
- C. Water produced during operations will be disposed of in the reserve pit.
- D. If any liquid hydrocarbons are produced during operations, those liquids will be stored in suitable tanks until sold.
- E. Current regulations regarding the proper disposal of human waste will be followed.
- F. All trash, junk, and other waste materials will be stored in proper containers to prevent dispersal and will be removed to an appropriate facility within one week of cessation of drilling and completion activities.

**7. Ancillary Facilities**

There are no ancillary facilities within the immediate vicinity of the proposed well site.

**8. Well Site Layout**

- A. A diagram of the drill pad is shown in Exhibit #5. Dimensions of the pad, pits, and location of major rig components are shown.
- B. The reserve pit will be lined with a high quality plastic sheeting to prevent migration of fluids.
- C. The pad dimension of 400' X 250' has been staked and flagged.

**9. Plans for Restoration of Surface**

- A. Upon cessation of the proposed operations, if the well is abandoned, the location and road will be ripped and re-seeded. The reserve pit area, after allowing to dry will be leveled. The entire location will be restored to the original contour as much as reasonable possible. All trash, garbage, and pit lining will be hauled to appropriate disposal to assure the location is aesthetically pleasing as reasonable possible. All restoration work will be completed within 180 days of cessation of activities.
- B. The disturbed area will be restored by re-seeding during the proper growing season.
- C. Three sides of the reserve pit will be fenced prior to and during drilling operations. The reserve pit will be fenced on the fourth side after the drilling rig is removed to prevent the endangerment of livestock. The fence will remain in place until the pit area has been leveled and restored.
- D. Upon cessation of the proposed operations, if the well is not abandoned, the reserve pit area will be restored as per OCD guidelines. Any additional caliche required for production facilities will be obtained from a source as described in Section 6.
- E. Within 90 days of cessation of drilling and completion operations, all equipment not necessary for production operations will be removed. The location will be cleaned of all trash and junk to assure the well site is left as aesthetically pleasing as reasonably possible.

**10. Surface Ownership:**

The surface is owned by: Walterscheid Trucking & Farms, Inc  
3226 Tidwell Road  
Carlsbad, NM 88220  
(505) 361-3432 (Phillip Walterscheid)

**11. Other Information:**

- A. Topography: Refer to the archaeological report for a detailed description of flora, fauna, soil characteristics, dwellings, and historical or cultural sites.
- B. The primary use of the surface at the location is for grazing of livestock.

**12. Operator's Representative:**

- A. Through APD approval, drilling, completion and production operations:

**N.M. Young, District Manager**  
Mewbourne Oil Company  
PO Box 5270  
Hobbs, NM 88241  
505-393-5905

**13. Certification**

I hereby certify that I, or persons under my direct supervision, have inspected the proposed drill site and access route; that I am familiar with the conditions which currently exist; that the statements made in this plan are to the best of my knowledge, true and correct; and the work associated with the operations proposed herein will be performed by Mewbourne Oil Company, its contractors and subcontractors, in accordance with this plan and the terms and conditions under which it is approved. This statement is subject to the provisions of 18 U.S.C. 1001 for the filing of a false statement.

Date: *Scotti Que for N.M. Young* Signature: 07/19/05

**N.M. Young, District Manager**  
Mewbourne Oil Company  
PO Box 5270  
Hobbs, NM 88241  
(505) 393-5905

**Hydrogen Sulfide Drilling Operations Plan**  
**Mewbourne Oil Company**  
Pecos River 20 #1  
868' FSL & 990' FEL  
Section 20-T22S-R27E  
Eddy County, New Mexico

1. Hydrogen Sulfide Training

All personnel, whether regularly assigned, contracted, or employed on an unscheduled basis, will have received training from a qualified instructor in the following areas prior to entering the drilling pad area of the well:

- A. The hazards and characteristics of hydrogen sulfide gas.
- B. The proper use of personal protective equipment and life support systems.
- C. The proper use of hydrogen sulfide detectors, alarms, warning systems, briefing areas, evacuation procedures.
- D. The proper techniques for first aid and rescue operations.

Additionally, supervisory personnel will be trained in the following areas:

- A. The effects of hydrogen sulfide on metal components. If high tensile tubular systems are utilized, supervisory personnel will be trained in their special maintenance requirements.
- B. Corrective action and shut in procedures, blowout prevention, and well control procedures while drilling a well.
- C. The contents of the Hydrogen Sulfide Drilling Operations Plan.

There will be an initial training session prior to encountering a known hydrogen sulfide source. The initial training session shall include a review of the site specific Hydrogen Sulfide Drilling Operations Plan.

2. Hydrogen Sulfide Safety Equipment and Systems

All hydrogen sulfide safety equipment and systems will be installed, tested, and operational prior to drilling below the intermediate casing.

- A. Well Control Equipment
  - 1. Flare line with automatic igniter or continuous ignition source.
  - 2. Choke manifold with minimum of one adjustable choke.
  - 3. Blowout preventers equipped with blind rams and pipe rams to accommodate all pipe sizes with properly sized closing unit
  - 4. Auxiliary equipment including rotating head and annular type blowout preventer.
- B. Protective Equipment for Essential Personnel

Thirty minute self contained work unit located at briefing area as indicated on well site diagram.

C. Hydrogen Sulfide Protection and Monitoring Equipment

Two portable hydrogen sulfide monitors positioned on location for optimum coverage and detection. The units shall have audible sirens to notify personnel when hydrogen sulfide levels exceed 20 ppm.

D. Visual Warning Systems

1. Wind direction indicators as indicated on the well site diagram.
2. Caution signs shall be posted on roads providing access to location. Signs shall be painted a high visibility color with lettering of sufficient size to be readable at reasonable distances from potentially contaminated areas.

3. **Mud Program**

The mud program has been designed to minimize the amount of hydrogen sulfide entrained in the mud system. Proper mud weight, safe drilling practices, and the use of hydrogen sulfide scavengers will minimize hazards while drilling the well.

4. **Metallurgy**

All tubular systems, wellheads, blowout preventers, drilling spools, kill lines, choke manifolds, and valves shall be suitable for service in a hydrogen sulfide environment when chemically treated.

5. **Communications**

State & County Officials phone numbers are posted on rig floor and supervisors trailer. Communications in company vehicles and tool pushers are either two way radios or cellular phones.

6. **Well Testing**

Drill stem testing is not an anticipated requirement for evaluation of this well. A drill stem test is required, it will be conducted with a minimum number of personnel in the immediate vicinity. The test will be conducted during daylight hours only.

7. **General Requirements**

MOC has researched this area and no high concentrations of H<sub>2</sub>S was found. MOC will have on location and working all H<sub>2</sub>S safety equipment before Delaware formations.

**Notes Regarding Blowout Preventer**

**Mewbourne Oil Company**

Pecos River 20 #1

868' FSL & 990' FEL

Section 20-T22S-R27E

Eddy County, New Mexico

1. Drilling nipple (bell nipple) to be constructed so that it can be removed without the use of a welder through the opening of the rotary table, with minimum internal diameter equal to blowout preventer bore.
2. Blowout preventer and all fittings must be in good condition with a minimum 5000 psi working pressure.
3. Safety valve must be available on the rig floor at all times with proper connections to install in the drill string. Valve must be full bore with minimum 5000 psi working pressure.
4. Equipment through which bit must pass shall be at least as large as internal diameter of the casing.
5. A kelly cock shall be installed on the kelly at all times.
6. Blowout preventer closing equipment to include and accumulator of at least 40 gallon capacity, two independent sources of pressure on closing unit, and meet all other API specifications.



Mewbourne Oil Company  
 BOP Scematic for  
 12 1/4" Hole

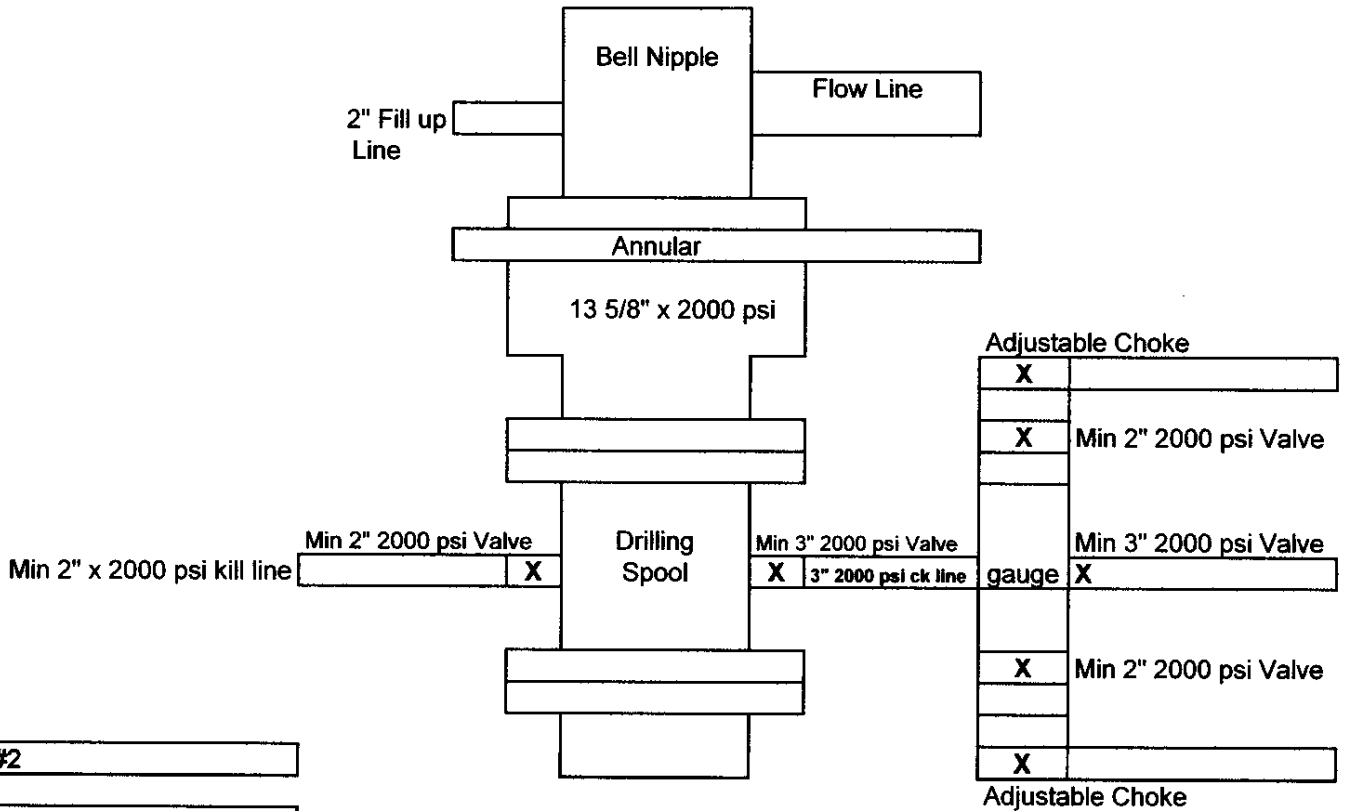

Exhibit #2

Pecos River 20 #1  
 868' FSL & 990' FEL  
 Section 20-T22S-R27E  
 Eddy County, New Mexico  
 New Mexico

Mewbourne Oil Company  
 BOP Scematic for  
 8 3/4" or 7 7/8" Hole

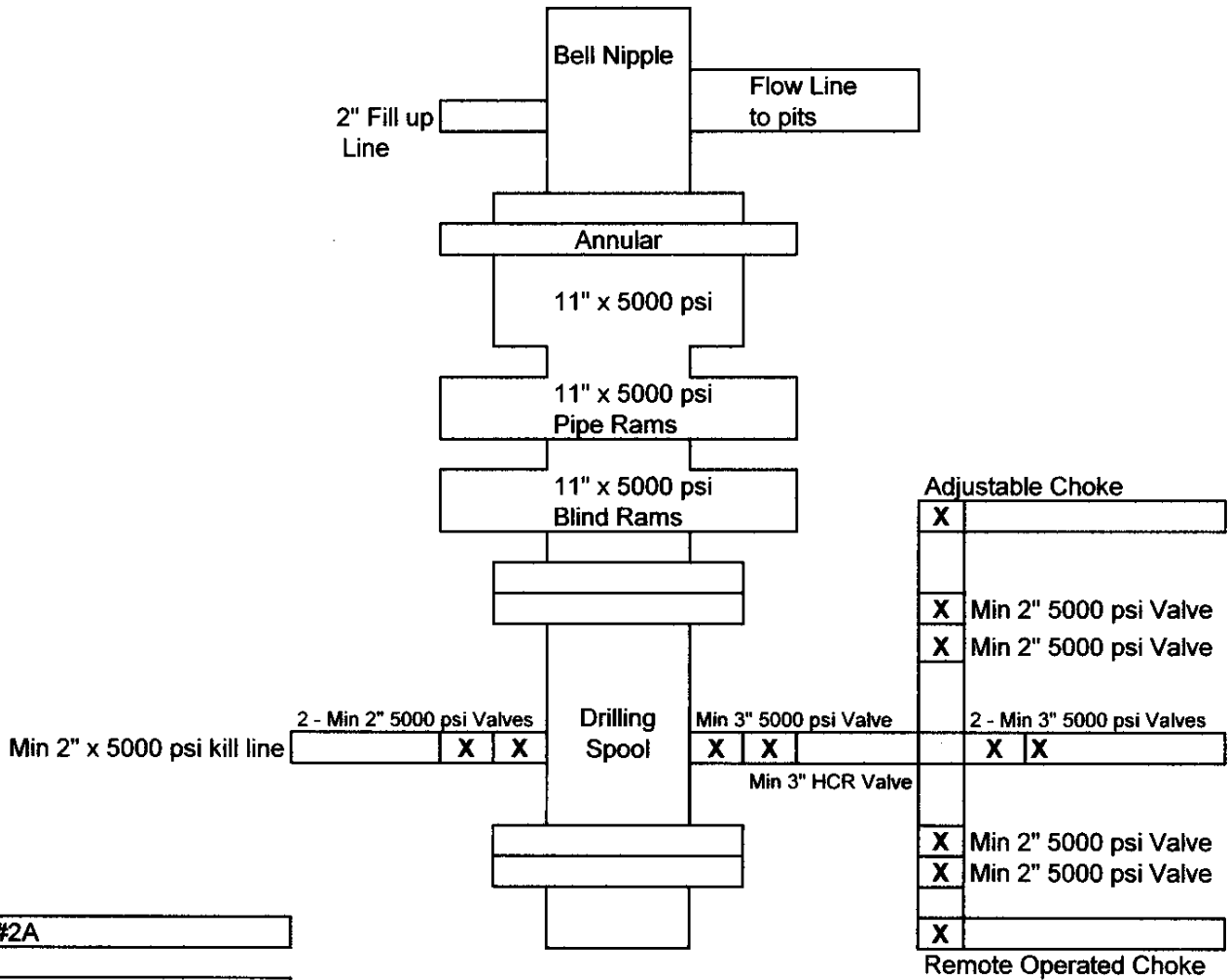
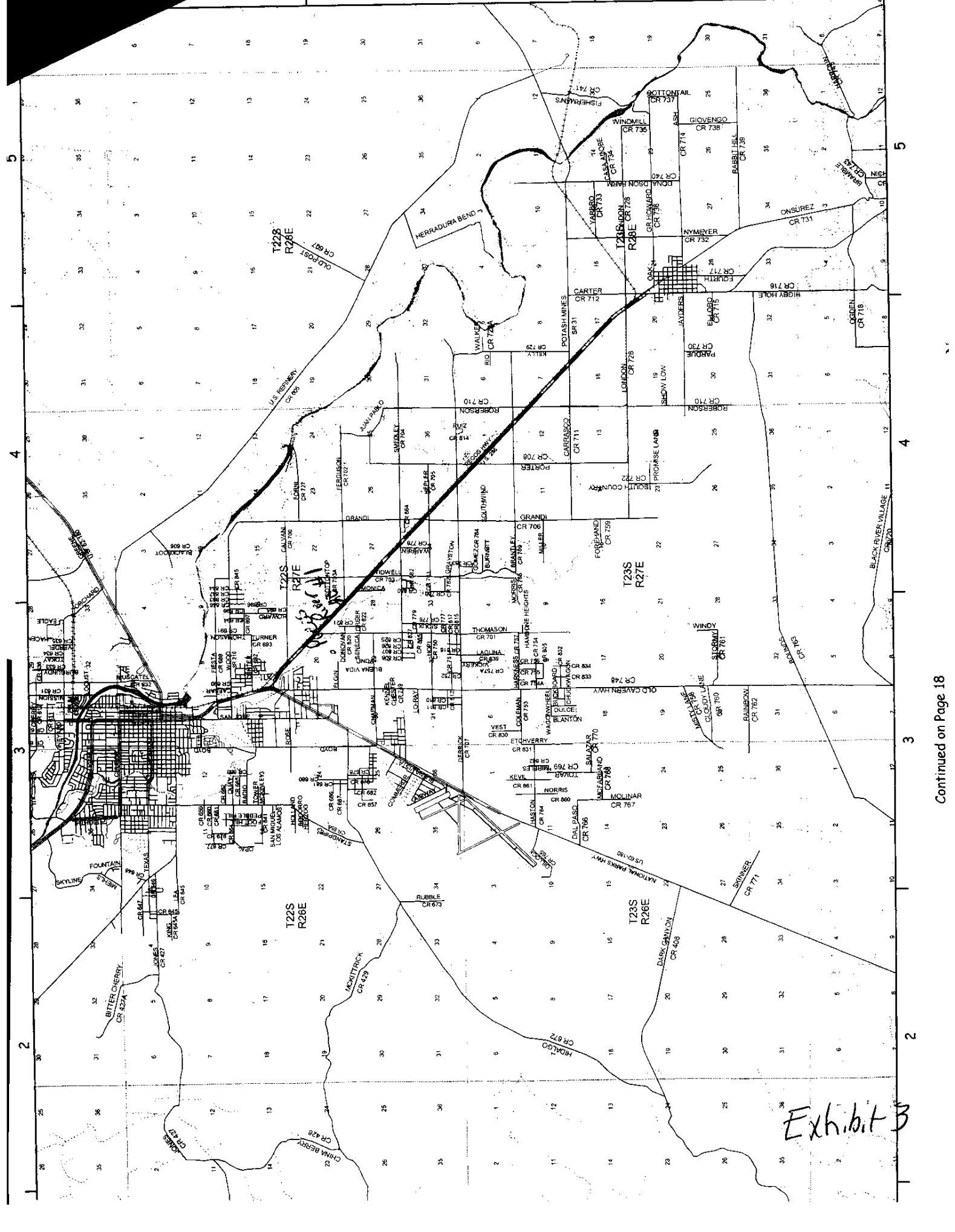

Exhibit #2A

Pecos River 20 #1  
 868' FSL & 990' FEL  
 Section 20-T22S-R27E  
 Eddy County, New Mexico  
 New Mexico



T225  
R26E

T225  
R27E

T235  
R27E

T225  
R26E

T235  
R26E

Exhibit B

SECTION 20, TOWNSHIP 22 SOUTH, RANGE 27 EAST, NMPM, EDDY COUNTY, NEW MEXICO.

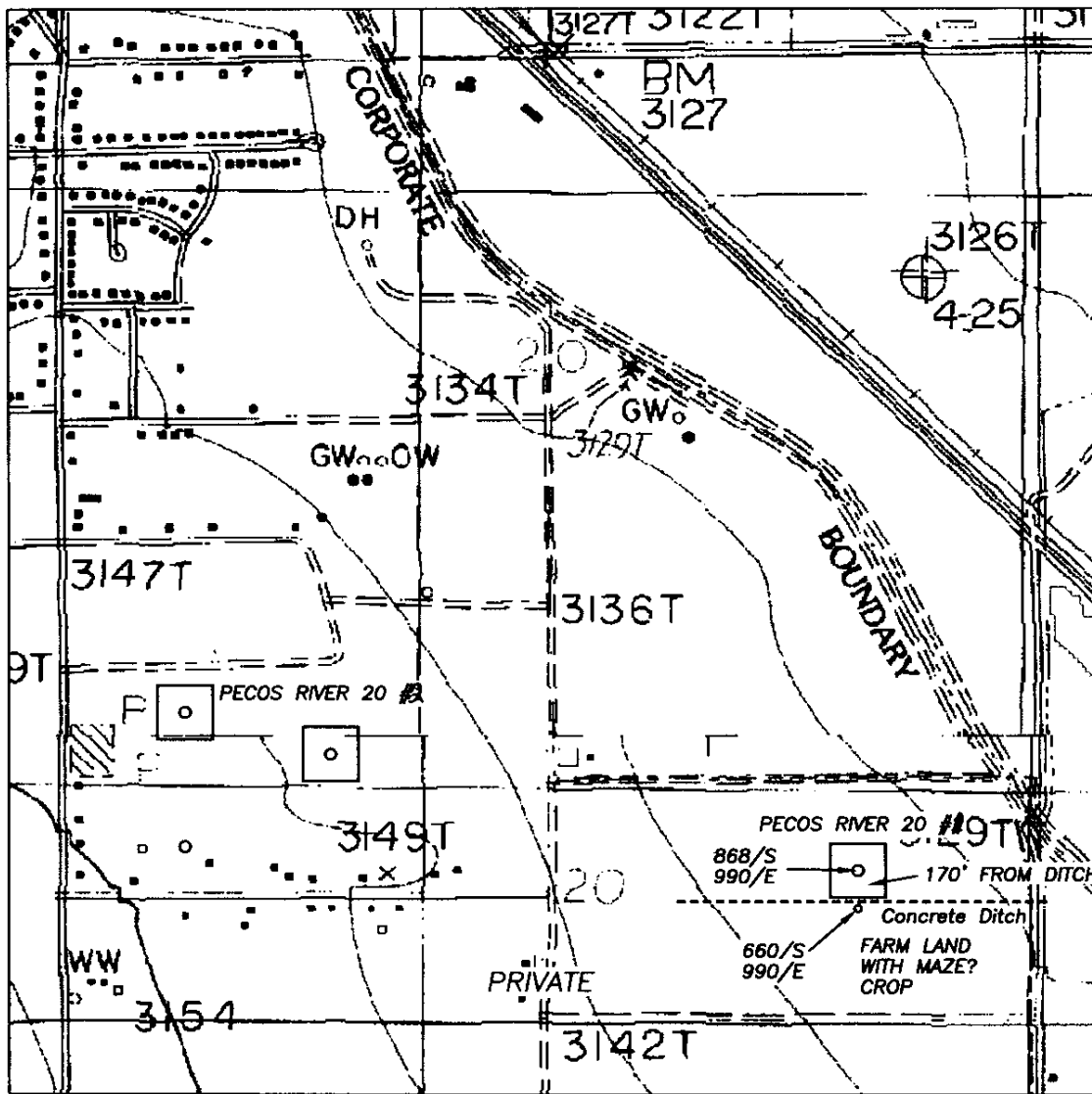

Exhibit 3A



THE PREPARATION OF THIS PLAT AND THE PERFORMANCE OF THE SURVEY UPON WHICH IT IS BASED WERE DONE UNDER MY DIRECTION AND THE PLAT ACCURATELY DEPICTS THE RESULTS OF SAID SURVEY AND MEET THE REQUIREMENTS OF THE STANDARDS FOR LAND SURVEYS IN NEW MEXICO AS ADOPTED BY THE NEW MEXICO STATE BOARD OF REGISTRATION FOR PROFESSIONAL ENGINEERS AND LAND SURVEYORS.



GENERAL SURVEYING COMPANY, P.O. BOX 1928  
LOVINGTON, NEW MEXICO 88260

### MEWBOURNE OIL COMPANY

LEASE ROAD TO ACCESS THE MEWBOURNE PECOS RIVER "20" #1 & 2 WELLS, LOCATED IN SECTION 20, TOWNSHIP 22 SOUTH, RANGE 27 EAST, NMPM, EDDY COUNTY, NEW MEXICO.

Survey Date: 6/06/2005	Sheet 1 of 1 Sheets
Drawn By: Ed Blevins	W.O. Number
Date: 6/06/05	Scale 1" = 1000' PECOS RIVER

# Mewbourne Oil Company

## Exhibit #5

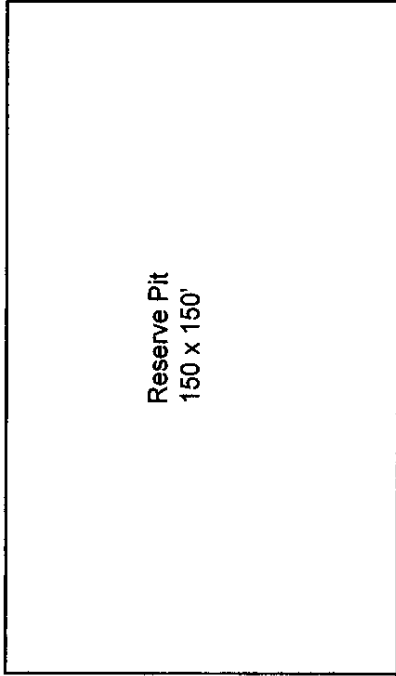

Well Name	Pecos River 20 #1
Footages	868' FSL & 990' FEL
STR	Sec 20-T22S-R27E
County	Eddy, County
State	New Mexico

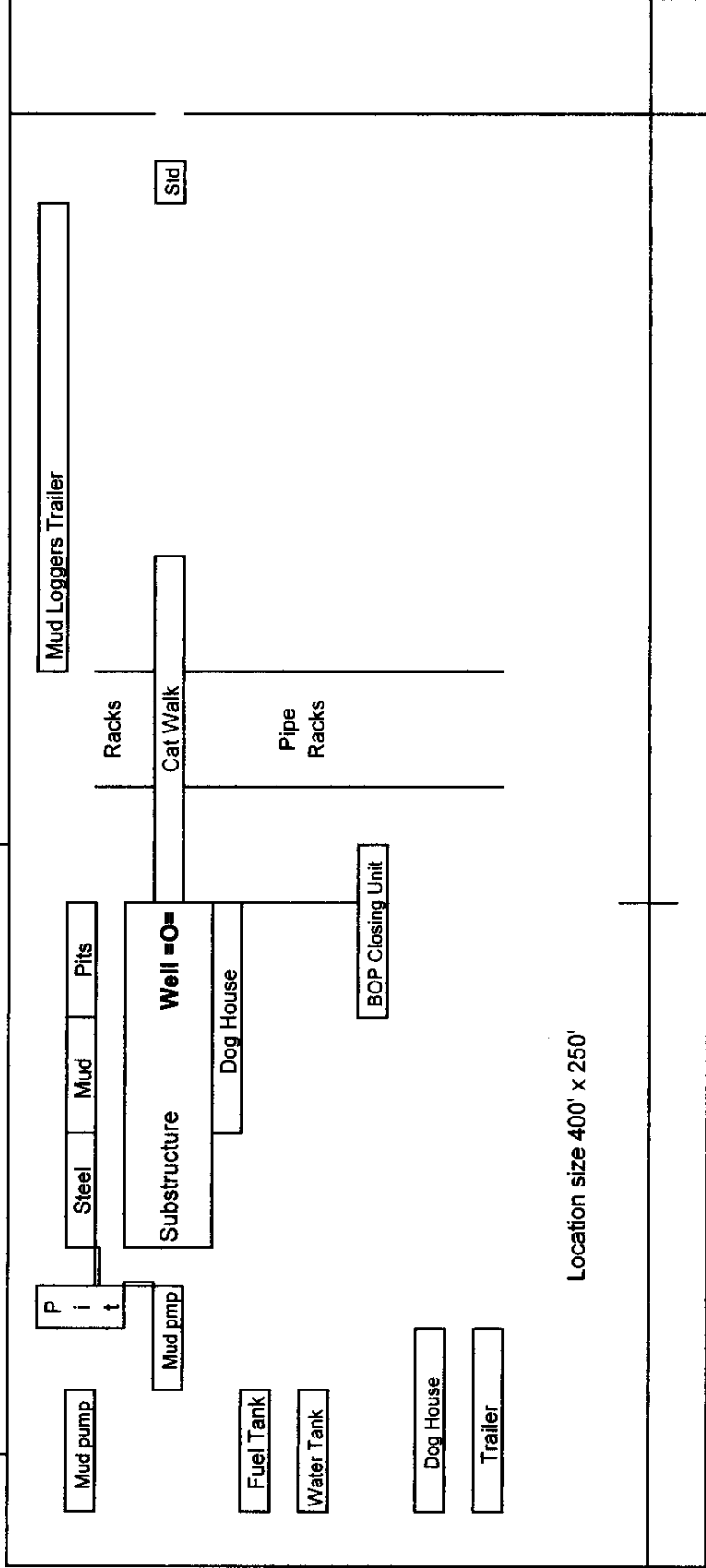

Rig Location Schematic

# Proposed Production Facilities Schematic

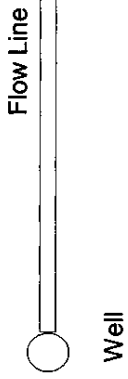
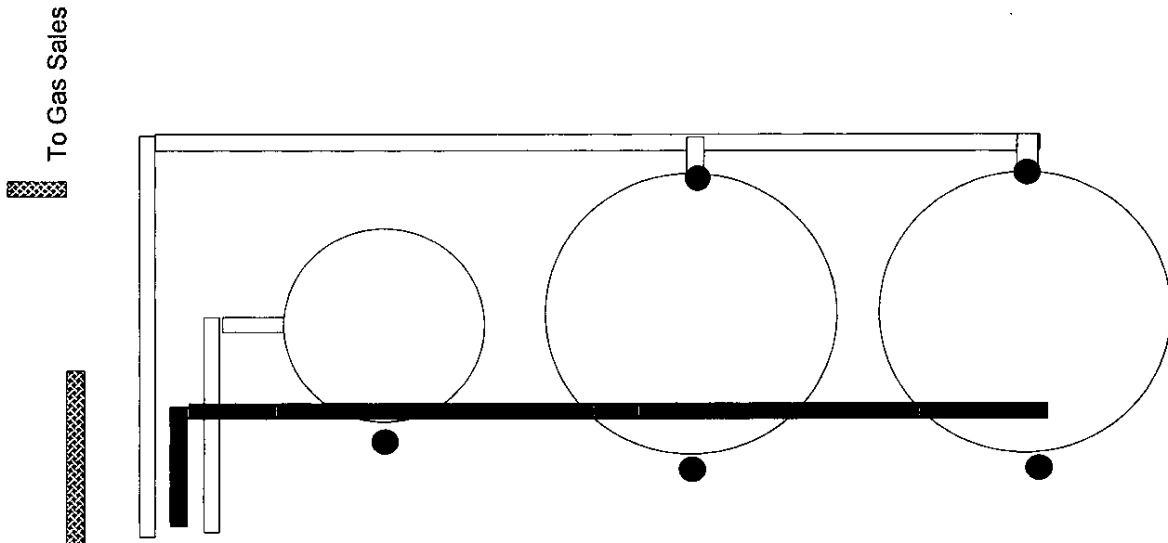

- Flow Line
- Water Line
- Oil Dump Line
- Gas Sales Line
- Sealing Valve ●
- Non Sealing Valve ○

**Mewbourne Oil Company**  
 Exhibit # 6  
 Proposed Production Facilities Schematic

Pecos River 20 #1  
 868' FSL & 990' FEL  
 Section 20-T22S-R27E  
 Eddy County  
 New Mexico

RECEIVED  
JUL 20 2005  
OCD-ARTEZIA

*H2S*

*CONTINGENCY PLAN*

*FOR*

*MEWBOURNE OIL*  
*COMPANY*

*PECOS RIVER 20 #1*  
*(868' FSL & 990' FEL of*  
*Sec 20-T22S-R27E)*

## Table of Contents

- I. H2S Contingency Plan Section
  - A. Scope
  - B. Objective
  - C. Discussion of Plan
- II. Emergency Procedures Section
  - A. Emergency Procedures
  - B. Emergency Reaction Steps
  - C. Simulated Blowout Control Drills
- III. Ignition Procedures Section
  - A. Responsibility
  - B. Instructions
- IV. Training Program Section
  - A. Training Requirements
- V. Emergency Equipment Section
  - A. Emergency Equipment Requirements
- VI. Check Lists Section
  - A. Status Check List
  - B. Procedural Check List
- VII. Briefing Procedure Section
  - A. Briefing Procedures
- VIII. Evacuation Plan Section
  - A. General Plan
  - B. Emergency Assistance Telephone List
- IX. Maps and Plats Section
  - A. Map showing Wellsite
  - B. Map showing Public within Radius of Exposure and Evacuation Routes
  - B. Emergency Call List of Residents and Businesses



X. General Information Section

- A. Drilling / Re-entry Permits
- B. 100 ppm Exposure Radius Chart
- C. 500 ppm Exposure Radius Chart
- D. Toxic Effects of Hydrogen Sulfide Poisoning
- E. Use of Self Contained Breathing Apparatus
- F. Rescue-First Aid for Hydrogen Sulfide Poisoning

## 1. H2S CONTINGENCY PLAN SECTION

### Scope

This contingency plan establishes guidelines for all company employees and contract employees whose work activities may involve exposure to Hydrogen Sulfide gas (H<sub>2</sub>S).

### Objective

1. Prevent any and all accidents and prevent the uncontrolled release of H<sub>2</sub>S into the atmosphere.
2. Provide proper evacuation procedures to cope with emergencies.
3. Provide immediate and adequate medical attention should an injury occur.

### Discussion of Plan

**Implementation:** This plan, with all details, is to be fully implemented before drilling below 1000'.

**Emergency Response Procedure:** This section outlines the conditions and denotes steps to be taken in the event of an emergency.

**Emergency Equipment and Procedure:** This section outlines the safety and emergency equipment that will be required for the drilling of this well.

**Training Provisions:** This section outlines the training provisions that must be adhered to prior to drilling below 1000'.

**Emergency Call Lists:** Included are the telephone numbers of all persons that would need to be contacted should an emergency occur.

**Briefing:** This section deals with the briefing of all people involved in the drilling operation.

**Public Safety:** Public Safety Personnel will be made aware of the drilling of this well.

**Check Lists:** Status Check Lists and Procedural Check Lists have been included to insure adherence to the plan.

**General Information:** A general information section has been included to supply support information.

## 2. EMERGENCY PROCEDURES SECTION

### Emergency Procedures

- I. In the event of any evidence of H<sub>2</sub>S level above 10 ppm, take the following steps immediately:
  - A. Secure breathing apparatus.
  - B. Order non-essential personnel out of the danger zone.
  - C. Take steps to determine if the H<sub>2</sub>S level can be corrected or suppressed and if so, proceed with normal operations.
  
- II. If uncontrollable conditions occur, proceed with the following:
  - A. Take steps to protect and / or remove any public downwind of the rig including partial evacuation or isolation. Notify necessary Public Safety personnel and Mewbourne Oil Company, Drilling Superintendent, Micky Young of the situation.
  - B. Remove all personnel to the Safe Briefing Area.
  - C. Notify public safety personnel for help with maintaining roadblocks and implementing evacuation.
  - D. Determine and proceed with the best possible plan to regain control of the well. Maintain tight security and safety procedures.
  
- III. Responsibility
  - A. The Company Approved Supervisor shall be responsible for the total implementation of the plan.
  - B. The Company Approved Supervisor shall be in complete command during any emergency.
  - C. The Company Approved Supervisor shall designate a back up Supervisor in the event that he / she is not available.

### 3. Emergency Procedure Implementation

#### I. Drilling or Tripping

##### A. All Personnel

1. When alarm sounds, don escape unit and report to upwind Safe Briefing Area
2. Check status of other personnel (Buddy System).
3. Secure breathing apparatus.
4. Await order from Supervisor

##### B. Drilling Foreman

1. Report to the upwind Safe Briefing Area.
2. Don breathing apparatus and return to the point of release with the Tool Pusher or Driller (Buddy System).
3. Determine the concentration of H<sub>2</sub>S.
4. Assess the situation and take appropriate control measures.

##### C. Tool Pusher

1. Report to the upwind Safe Briefing Area.
2. Don breathing apparatus and return to the point of release with the Drilling Foreman or Driller (Buddy System).
3. Determine the concentration of H<sub>2</sub>S.
4. Assess the situation and take appropriate control measures.

##### D. Driller

1. Don escape unit.
2. Check monitor for point of release.
3. Report to the Safe Briefing Area.
4. Check the status of other personnel (in a rescue attempt, always use the buddy system).
5. Assign the least essential person to notify the Drilling Foreman and Tool Pusher, in the event of their absence.
6. Assume the responsibility of the Drilling Foreman and Tool Pusher until they arrive, in the event of their absence.

E. Derrick Man

1. Remain in the Safe Briefing Area until otherwise instructed by Supervisor.

F. Mud Engineer

1. Report to Safe Briefing Area.
2. When instructed, begin check of mud for pH level and H2S level.

G. Safety Personnel

1. Don appropriate breathing apparatus.
2. Check status of all personnel.
3. Await instructions from Drilling Foreman

II. Taking a Kick

- A. All personnel report to Safe Briefing Area.
- B. Follow standard BOP procedures.

III. Open Hole Logging

- A. All unnecessary personnel should leave the rig floor.
- B. Drilling Foreman and Safety personnel should monitor the conditions and make necessary safety equipment recommendations.

IV. Running Casing or Plugging

- A. Follow "Drilling or Tripping" procedures.
- C. Assure that all personnel have access to protective equipment.

#### 4. Simulated Blowout Control Drills

All drills will be initiated by activating alarm devices (air horn). One long blast, on air horn, for Actual and Simulated Blowout Control Drills. The Drilling Foreman or Tool Pusher will perform this operation at least one time per week for each of the following conditions, with each crew:

- |         |                     |
|---------|---------------------|
| Drill 1 | Bottom Drilling     |
| Drill 2 | Tripping Drill Pipe |

In each of these drills, the initial reaction time to shutting in the well shall be timed as well as the total time for the crew to complete its entire pit drill assignment. The times must be recorded on the IADC Driller's Log as "Blowout Control Drill".

Drill No.: \_\_\_\_\_

Reaction time to shut-in: \_\_\_\_\_ minutes, \_\_\_\_\_ seconds.

Total time to complete assignment: \_\_\_\_\_ minutes, \_\_\_\_\_ seconds.

##### I. Drill Overviews

###### A. Drill No. 1--Bottom Drilling

1. Sound the alarm immediately
2. Stop the rotary and hoist the kelly joint above the rotary table.
3. Stop the circulatory pump.
4. Close drill pipe rams.
5. Record casing and drill pipe shut-in pressures and pit volume increases.

###### B. Drill No. 2--Tripping Drill Pipe

1. Sound the alarm immediately
2. Position the upper tool joint just above the rotary table and set slips.
3. Install a full opening valve or inside blowout preventer tool in order to close the drill pipe.
4. Close the drill pipe rams.
5. Record the shut-in annular pressure.

## II. Crew Assignments

### A. Drill No. 1--Bottom Drilling

#### 1. Driller

- a. Stop the rotary and hoist Kelly joint above the rotary table.
- b. Stop the circulatory pump.
- c. Check flow.
- d. If flowing, sound the alarm immediately.
- e. Record the shut-in drill pipe pressure.
- f. Record all data reported by the crew.
- g. Determine the mud weight increase needed or other courses of action.

#### 2. Derrickman

- a. Open choke line valve at BOP.
- b. Signal Floor Man #1 at accumulator, that choke line is open.
- c. Close choke and upstream valve after pipe tams have been closed.
- d. Read the shut-in annular pressure and report readings to Driller.

#### 3. Floor Man #1

- a. Close the pipe tams after receiving the signal from the Derrickman.
- b. Report to Driller for further instructions.

#### 4. Floor Man #2

- a. Notify the Tool Pusher and Operator Representative of the H<sub>2</sub>S alarms.
- b. Check for open fires and if safe to do so, extinguish them.
- c. Stop all welding operations.
- d. Turn off all non-explosion proof lights and instruments.
- e. Report to Driller for further instructions.

5. Tool Pusher
    - a. Report to the rig floor.
    - b. Have a meeting with all crews.
    - c. Compile and summarize all information.
    - d. Calculate the proper kill weight.
    - e. Ensure that proper well procedures are put into action.
  6. Operator Representative
    - a. Notify the Drilling Superintendent.
    - b. Determine if an emergency exists and if so, activate the contingency plan.
- B. Drill No. 2-Tripping Pipe
1. Driller
    - a. Sound the alarm immediately when mud volume increase has been detected.
    - b. Position the upper tool joint just above the rotary table and set slips.
    - c. Install a full opening valve or inside blowout preventor tool to close the drill pipe.
    - d. Check flow.
    - e. Record all data reported by the crew.
    - f. Determine the course of action.
  2. Derrickman
    - a. Come down out of derrick.
    - b. Notify Tool Pusher and Operator Representative.
    - c. Check for open fires and, if safe to do so, extinguish them.
    - d. Stop all welding operations.
    - e. Report to Driller for further instructions.



3. Floor Man #1
  - a. Pick up full opening valve or inside blowout preventors and stab into tool joint above rotary table (with Floor Man #2).
  - b. Tighten valve with back-up tongs.
  - c. Close pipe rams after signal from Floor Man #2.
  - d. Read accumulator pressure and check for possible high-pressure fluid leaks in valves or piping.
  - e. Report to Driller for further instructions.
4. Floor Man #2
  - a. Pick-up full opening valve or inside blowout preventors and stab into tool joint above rotary table (with Floor Man #1).
  - b. Position back-up tongs on drill pipe.
  - c. Open choke line valve at BOP.
  - d. Signal Floor Man #1, at accumulator, that choke line is open.
  - e. Close choke and upstream valve after pipe rams have been closed.
  - f. Check for leaks on BOP stack and choke manifold.
  - g. Read annular pressure.
  - h. Report readings to the Driller.
5. Tool Pusher
  - a. Report to rig floor.
  - b. Have a meeting with all crews.
  - c. Compile and summarize all information.
  - d. Calculate proper kill weight.
  - e. See that proper well kill procedures are put into action.
6. Operator Representative
  - a. Notify Drilling Superintendent.
  - b. Determine if an emergency exists, and if so, activate the contingency plans.

### III. IGNITION PROCEDURES SECTION

#### Responsibility

The decision to ignite the well is the responsibility of the **DRILLING FOREMAN** in concurrence with the **STATE POLICE**. In the event the Drilling Foreman is incapacitated, it becomes the responsibility of the **RIG TOOL PUSHER**. This decision should be made only as a last resort and in a situation where it is clear that:

1. Human life and property are endangered.
2. There is no hope of controlling the blowout under the prevailing conditions.

If time permits, notify the main office, but do not delay if human life is in danger. Initiate the first phase of the evacuation plan.

#### Instructions for Igniting the Well

1. Two people are required for the actual igniting operation. Both men must wear self-contained breathing apparatus and attach a safety rope. One man must monitor the atmosphere for explosive gases with the Explosimeter, while the Drilling Foreman is responsible for igniting the well.
2. The primary method to ignite is a 25mm flare gun with a range of approximately 500 feet.
3. Ignite from upwind and do not approach any closer than is warranted.
4. Select the ignition site best suited for protection and which offers an easy escape route.
5. Before igniting, check for the presence of combustible gases.
6. After igniting, continue emergency actions and procedures as before.
7. All unassigned personnel will limit their actions to those directed by the Drilling Foreman.

**NOTE:** After the well is ignited, burning Hydrogen Sulfide will convert to Sulfur Dioxide, which is also highly toxic. Do not assume the area is safe after the well is ignited.

#### IV. TRAINING PROGRAM SECTION

##### Training Requirements

When working in an area where Hydrogen Sulfide gas (H<sub>2</sub>S) might be encountered, definite training requirements must be carried out. The Company Supervisor will insure that all personnel, at the wellsite, have had adequate training in the following:

1. Hazards and characteristics of H<sub>2</sub>S.
2. Physical effects of Hydrogen Sulfide on the human body.
3. Toxicity of Hydrogen Sulfide and Sulfur Dioxide.
4. H<sub>2</sub>S detection.
5. Emergency rescue.
6. Resuscitators.
7. First aid and artificial resuscitation.
8. The effects of H<sub>2</sub>S on metals.
9. Location Safety.

Service company personnel and visiting personnel must be notified in the zone contains H<sub>2</sub>S. Each service company must provide adequate training and equipment for their employees before they arrive at the well site.

## EMERGENCY EQUIPMENT SECTION

### Emergency Equipment Requirements

- I. Signs
- A. Located at the location entrance with the following information:
- CAUTION - POTENTIAL POISON GAS  
HYDROGEN SULFIDE  
NO ADMITTANCE WITHOUT AUTHORIZATION**
- II.\* Fresh air breathing equipment
- A. Air line units for all rig personnel on location.
- B. Cascade system with hose lines to rig floor and one to the derrickman and other operation areas. Spare cascade (trailer) on location.
- III. Wind Socks or Wind Streamers
- A. Two 10" windsocks located at strategic locations at a height visible from the rig floor.
- B. Wind streamers (if preferred) to be placed at various locations on the wellsite to insure wind consciousness at all times. (Corners of location).
- IV. Hydrogen Sulfide detector and alarms.
- A. 1 - four channel H<sub>2</sub>S monitor with alarms.
- B. 4 - Sensors, located at floor, bell nipple, shale shaker and pits.0
- \* C. Hand operated detectors with tubes.
- \* D. H<sub>2</sub>S monitor tester.
- V. Condition sign and flags
- A. One each of green, yellow and red condition flags to be displayed to denote conditions:
- |               |                                       |
|---------------|---------------------------------------|
| <b>GREEN</b>  | <b>Normal Conditions</b>              |
| <b>YELLOW</b> | <b>Potential Danger</b>               |
| <b>RED</b>    | <b>Danger, H<sub>2</sub>S Present</b> |
- B. The condition flag shall be posted at the location entrance.
- VI.\* Auxiliary rescue equipment
- A. Stretcher
- B. Two 100' lengths of 5/8" nylon rope.
- VII.\* Mud Inspection devices
- A. Garrett Gas Train or Hach Tester for inspection of Hydrogen Sulfide concentration in the mud system.
- VIII. Fire Extinguishers
- A. Adequate fire extinguishers shall be located at strategic locations.
- IX. Blowout prevention equipment
- A. The well shall have hydraulic BOP equipment for the anticipated BHP.
- B. Equipment must be tested upon installation.
- X.\* Combustible gas detectors
- A. There shall be one combustible gas detector on location at all times.
- XI. BOP Testing
- A. BOP, Choke Line and Kill Line will be tested as specified by operator

XII. Audio System

- A. Radio/cellular communications shall be available at the rig.
- B. Radio/cellular communications shall be available at the rig floor or trailer.
- C. Radio/cellular communications shall be available on vehicles.

XIII. Special control equipment

- A. Hydraulic BOP equipment with remote control on ground.
- B. Rotating head at surface casing point.

XIV. Evacuation Plan

- A. Evacuation routes should be established prior to spudding each well.
- B. Should be discussed with all rig personnel.

XV. Designated Areas

- A. Parking and visitor area.
  - 1. All vehicles are to be parked at a pre-determined safe distance from the wellhead.
  - 2. Designated smoking area.
- B. Safe Briefing Area
  - 1. Two Safe Briefing Areas shall be designated on either side of the location at the maximum allowable distance from the well bore so they offset prevailing winds or they are at a 180 degree angle if wind directions tend to shift in the area.
  - 2. Personal protective equipment should be stored in both protection centers or if a moveable trailer is used, it should be kept upwind of existing winds. When wind is from the prevailing direction, both protection centers should be accessible.

- \*Additional equipment will be available at Callaway Safety Equipment Co., Inc., (505) 392-2973, 3229 Industrial, Hobbs, New Mexico, 88240.
- Additional personal Hydrogen Sulfide monitors on location for all hands.
- Automatic Flare igniter installed on rig.

VI. CHECK LIST SECTION

Status Check List

**NOTE:** Date each item as they are implemented.

1. Sign at location entrance \_\_\_\_\_
2. Two (2) windsocks (in required locations) \_\_\_\_\_
3. Wind streamers (if required) \_\_\_\_\_
4. 30 minute pressure demand air packs on location for all rig personnel and mud loggers. \_\_\_\_\_
5. Air packs, inspected and ready for use. \_\_\_\_\_
6. Spare bottles for each air pack (if required) \_\_\_\_\_
7. Cascade system and hose line hook up \_\_\_\_\_
8. Cascade system for refilling air bottles \_\_\_\_\_
9. Choke manifold hooked up and tested (Before drilling out surface casing) \_\_\_\_\_
10. Remote Hydraulic BOP control (hooked up and tested before drilling out surface casing) \_\_\_\_\_
11. BOP Preventor tested (before drilling out surface casing) \_\_\_\_\_
12. Mud engineer on location with equipment to test mud for Hydrogen Sulfide \_\_\_\_\_
13. Safe Briefing Areas set up \_\_\_\_\_
14. Condition sign and flags on location and ready \_\_\_\_\_
15. Hydrogen Sulfide detection system hooked up \_\_\_\_\_
16. Hydrogen Sulfide alarm system hooked up \_\_\_\_\_
17. Stretcher on location at Safe Briefing Area \_\_\_\_\_
18. 1 - 100' length of 5/8" nylon rope on location \_\_\_\_\_
19. 1 - 20 # or 30 # ABC fire extinguisher in safety trailer in addition to those on rig \_\_\_\_\_
20. Combustible gas detector on location and tested \_\_\_\_\_
21. All rig crews and supervisors trained (as required) \_\_\_\_\_

- 22. Access restricted for unauthorized personnel \_\_\_\_\_
- 23. Drills on H2S and well control procedures \_\_\_\_\_
- 24. All outside service contractors advised of potential Hydrogen Sulfide on well \_\_\_\_\_
- 25. **NO SMOKING** sign posted \_\_\_\_\_
- 26. Hand operated H2S detector with tubes on location \_\_\_\_\_
- 27. 25 mm flare gun with flares \_\_\_\_\_
- 28. Automatic Flare igniter installed on rig \_\_\_\_\_

## Procedural Check List

### Perform the following on each tour:

1. Check fire extinguishers to see that they have the proper charge.
2. Check breathing equipment to insure that it has not been tampered with.
3. Check pressure on supply air bottles to see that they are capable of recharging.
4. Make sure all of the Hydrogen Sulfide detection systems are operative.

### Perform the following each week:

1. Check each piece of breathing equipment to make sure that the demand regulator is working. This requires that the bottle be opened and the mask assembly be put on tight enough so that when you inhale, you get air.
2. Blowout preventor skills.
3. Check supply pressure on BOP accumulator stand-by source.
4. Check all work/escape units for operation: demand regulator, escape bottle air volumes, supply bottle air volume.
5. Check breathing equipment mask assembly to see that straps are loosened and turned back.
6. Check pressure on breathing equipment air bottles to make sure they are charged to full volume.
7. Check breathing equipment air bottles to make sure all demand regulators are working. This requires that the bottles be opened and the mask assembly be put on tight enough so that when you inhale, you get air.
8. Confirm pressure on all supply air bottles.
9. Perform breathing equipment drills with on-site personnel.

### Check the following supplies for availability:

- a. Stretcher
  - b. Safety belts and ropes
  - c. Emergency telephone lists
  - d. Spare air bottle
  - e. Spare oxygen bottles (if resuscitator required)
  - f. Hand operated H<sub>2</sub>S detectors and tubes
10. Test the Explosimeter to verify batteries are good.



## VII. BRIEFING PROCEDURE SECTION

### Briefing Procedures

The following scheduled briefings will be held to insure the effective drilling and operation of this project:

#### Pre-Spud Meeting

**Date:** Prior to spudding the well

**Attendance:** Drilling Supervisor  
Drilling Engineer  
Drilling Foreman  
Rig Pushers  
Rig Driller  
Mud Engineer  
All Safety Personnel  
Service Companies

**Purpose:** Review and discuss the well program, step by step, to insure complete understanding of assignments and responsibilities.

## VIII. EVACUATION PLAN SECTION

### General Plan

The direct lines of action prepared by CALLAWAY SAFETY EQUIPMENT CO., INC. to protect the public from hazardous gas situations are as follows:

1. When the company approved supervisor (Drilling Foreman, Tool Pusher, Driller) determine Hydrogen Sulfide gas cannot be limited to the well location and the public will be involved, he will activate the evacuation plan. Escape routes are noted on the Area map.
2. Company safety personnel or designee will notify the appropriate local government agency that a hazardous condition exists and evacuation needs to be implemented.
3. Company approved safety personnel that have been trained in the use of Hydrogen Sulfide detection equipment and self-contained breathing equipment will be utilized.
4. Law Enforcement personnel (State Police, Sheriff's Department, local Police Department and local Fire Department) will be called to aid in setting up and maintaining road blocks. Also, they will aid in evacuation of the public if necessary.

**NOTE:** Law enforcement personnel will not be asked to come into a contaminated area. Their assistance will be limited to uncontaminated areas. Constant radio contact will be maintained with them.

5. After the discharge of gas has been controlled, "Company" safety personnel will determine when the area is safe for re-entry.

See Emergency Reaction Plan

## EMERGENCY ASSISTANCE TELEPHONE LIST

### PUBLIC SAFETY

---

Carlsbad P.D.	(505) 885-2111 or 911
Eddy County Sheriff's Department	(505) 746-9888 or 911
New Mexico State Police	(505) 622-7200 or 911
Fire Department (Artesia)	(505) 746-5050 or 911
New Mexico, OCD (Tim Gum)	(505) 748-1283
New Mexico, D.O.T.	(505) 827-5100
Bureau of Land Management	(505) 393-3612
U.S. Dept. of Labor	(505) 248-5302
State Emergency Operation Center	(505) 476-9635

### MEWBOURNE OIL CO.

---

Frosty Latham	Drilling Foreman	(505) 390-4103 (mobile)
		(505) 738-8040 (home)

Micky Young	Drilling Superintendent	(505) 390-0999
		(505) 392-0869

### SAFETY CONTRACTOR

---

Callaway Safety Equipment	Hobbs	(505) 393-2973
	Odessa	(915) 561-5049

**Affected Public Notification List**  
(within a 65' radius of exposure @ 100 ppm)

The geologic zones that will be encountered during drilling are known to contain hazardous quantities of H<sub>2</sub>S. The accompanying map illustrates the affected areas of the community. The residents within this radius will be notified via a hand delivered written notice describing the activities, potential hazards, conditions of evacuation, evacuation drill siren alarms and other precautionary measures.

**Evacuee Description:** Residents - There are no residents that live within 1000'.

**Notification Process:** A continuous siren audible to all residents will be activated, signaling evacuation of previously notified and informed residents.

**Evacuation Plan:** All evacuees will migrate lateral to the wind direction.

The Oil Company will identify all homebound or highly susceptible individuals and make special evacuation preparations, interfacing with the local fire and emergency medical services as necessary.

**IX. MAPS AND PLATS SECTION**

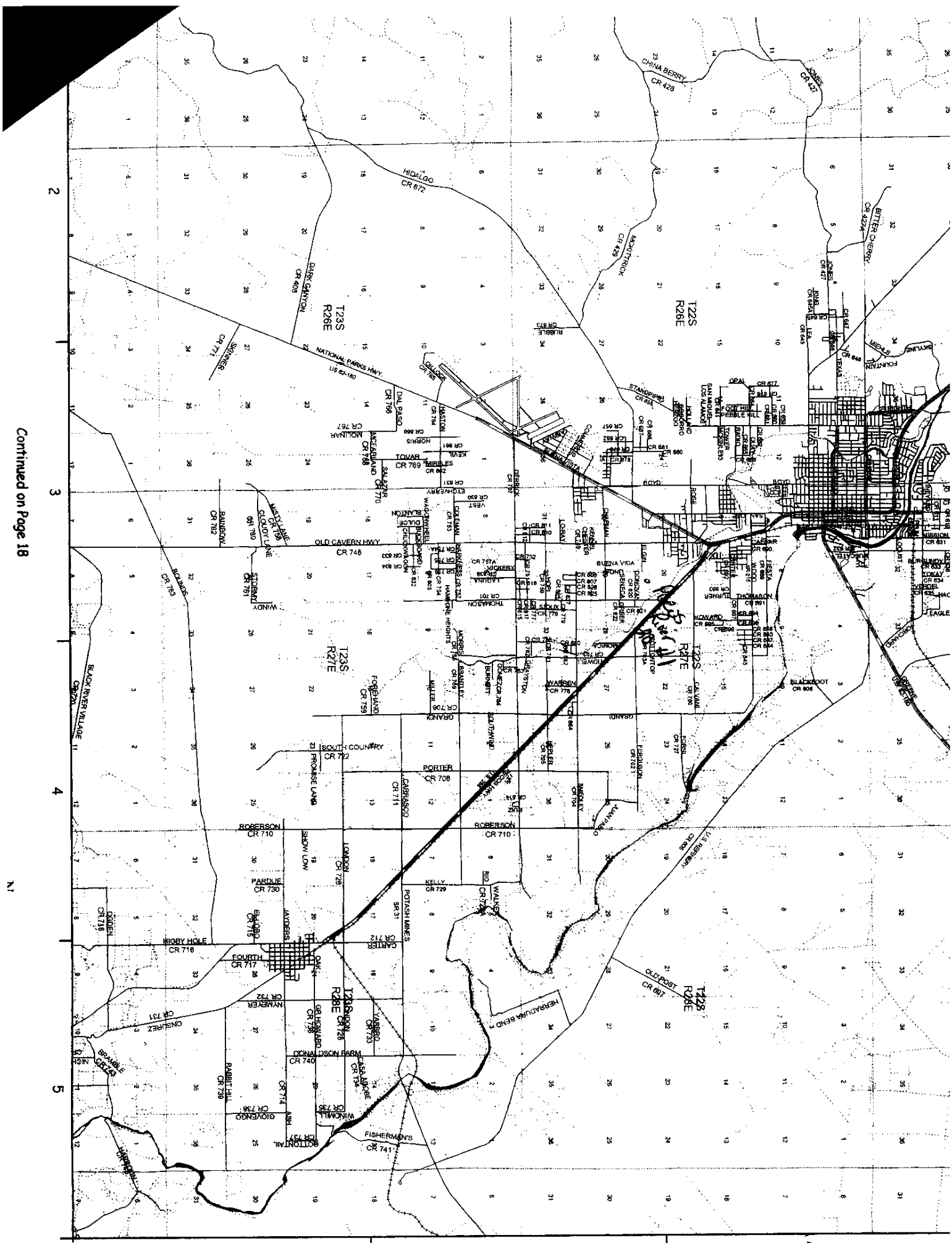

Continued on Page 18



DISTRICT II  
 1000 Rio Brazos Rd., Artesia, NM 88210  
 DISTRICT III  
 1000 Rio Brazos Rd., Artesia, NM 87410  
 DISTRICT IV  
 2040 South Pacheco, Santa Fe, NM 87505

**OIL CONSERVATION DIVISION**  
 P.O. Box 2088  
 Santa Fe, New Mexico 87504-2088

AMENDED REPORT

**WELL LOCATION AND ACREAGE DEDICATION PLAT**

API Number	Pool Code	Pool Name South Carlsbad Morrow
Property Code	Property Name PECOS RIVER "20"	Well Number 8 /
OGRID No. 14744	Operator Name MEWBOURNE OIL COMPANY	Elevation 3128

**Surface Location**

UL or lot No.	Section	Township	Range	Lot Idn	Feet from the	North/South line	Feet from the	East/West line	County
P	20	22S	27E		868	SOUTH	990	EAST	EDDY

**Bottom Hole Location If Different From Surface**

UL or lot No.	Section	Township	Range	Lot Idn	Feet from the	North/South line	Feet from the	East/West line	County

Dedicated Acres	Joint or Infill	Consolidation Code	Order No.
320			

**NO ALLOWABLE WILL BE ASSIGNED TO THIS COMPLETION UNTIL ALL INTERESTS HAVE BEEN CONSOLIDATED OR A NON-STANDARD UNIT HAS BEEN APPROVED BY THE DIVISION**

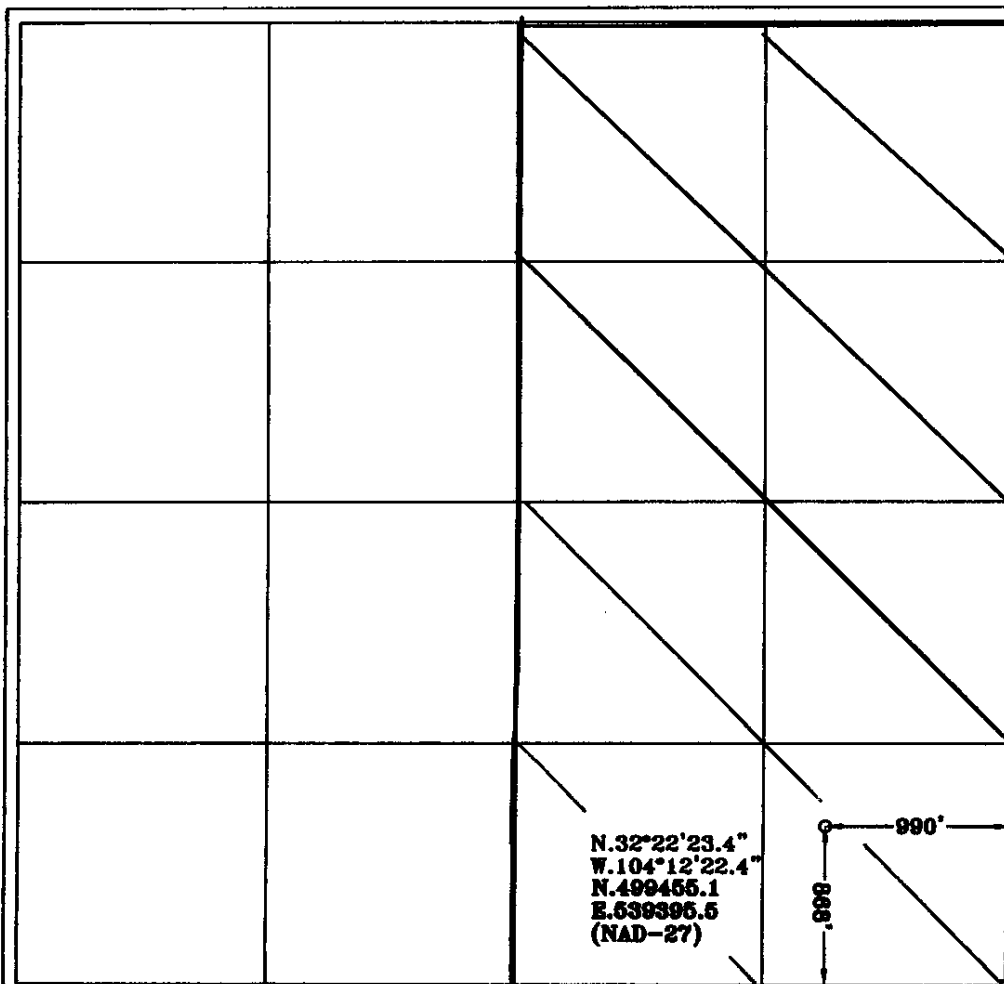

**OPERATOR CERTIFICATION**

*I hereby certify that the information contained herein is true and complete to the best of my knowledge and belief.*

*Kristi Green*  
 Signature  
 Kristi Green  
 Printed Name  
 Hobbs Regulatory  
 Title  
 06/22/05  
 Date

---

**SURVEYOR CERTIFICATION**

*I hereby certify that the well location shown on this plat was plotted from field notes of actual surveys made by me or under my supervision, and that the same is true and correct to the best of my belief.*

6/07/2005  
 Date Surveyed

Signature & Seal of Professional Surveyor

Certificate No. Herschel L. Jones, RLS 3640  
 PECOS RIVER "20"  
 GENERAL SURVEYING COMPANY

0 330' 660' 990' 1650' 1980' 2310' 2310' 1980' 1650' 990' 660' 330' 0'





x. GENERAL INFORMATION SECTION

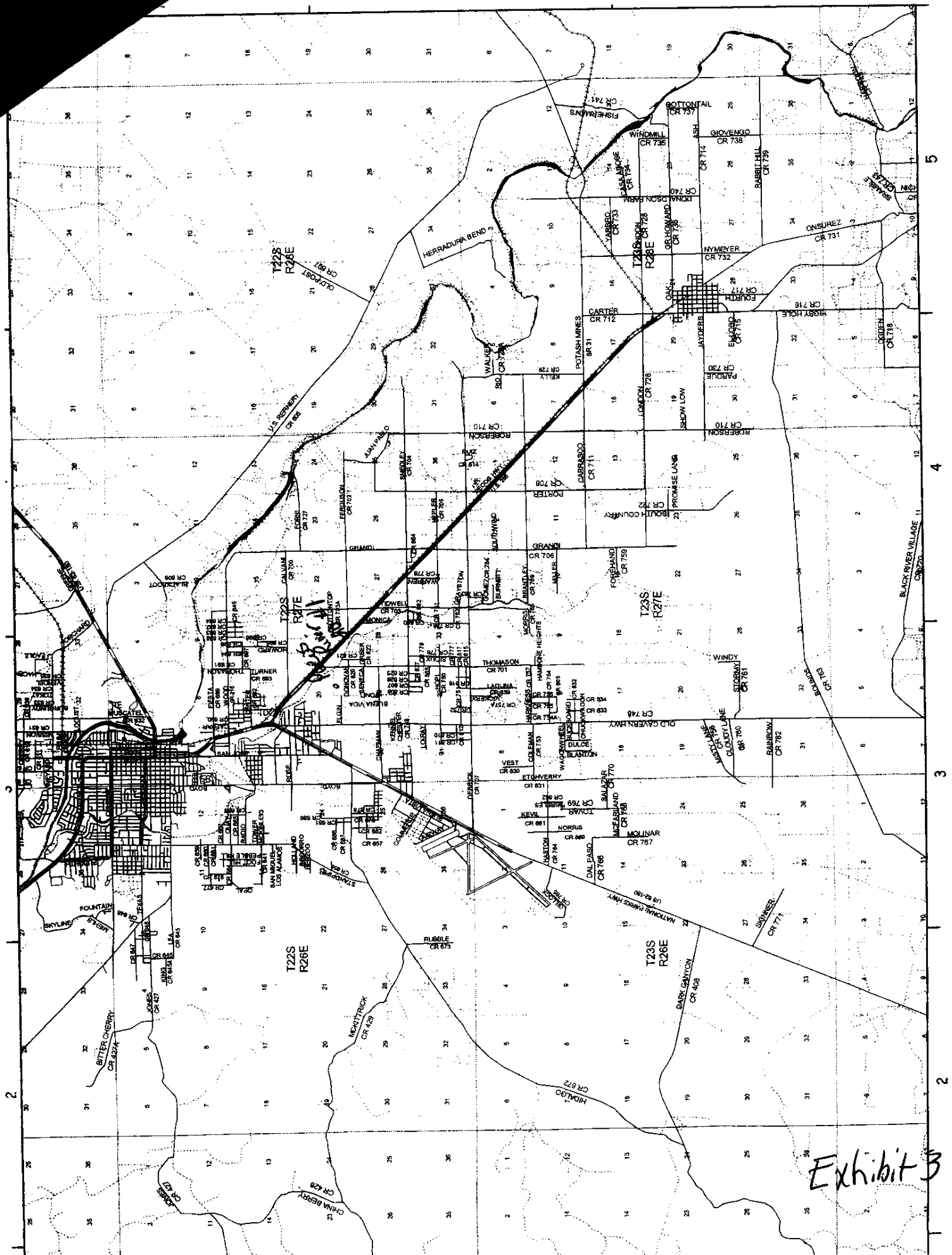

*Handwritten note:*  
R26E  
R27E  
R28E  
R29E  
R30E  
R31E  
R32E  
R33E  
R34E  
R35E  
R36E  
R37E  
R38E  
R39E  
R40E  
R41E  
R42E  
R43E  
R44E  
R45E  
R46E  
R47E  
R48E  
R49E  
R50E  
R51E  
R52E  
R53E  
R54E  
R55E  
R56E  
R57E  
R58E  
R59E  
R60E  
R61E  
R62E  
R63E  
R64E  
R65E  
R66E  
R67E  
R68E  
R69E  
R70E  
R71E  
R72E  
R73E  
R74E  
R75E  
R76E  
R77E  
R78E  
R79E  
R80E  
R81E  
R82E  
R83E  
R84E  
R85E  
R86E  
R87E  
R88E  
R89E  
R90E  
R91E  
R92E  
R93E  
R94E  
R95E  
R96E  
R97E  
R98E  
R99E  
R100E

*Handwritten text:*  
Exhibit B

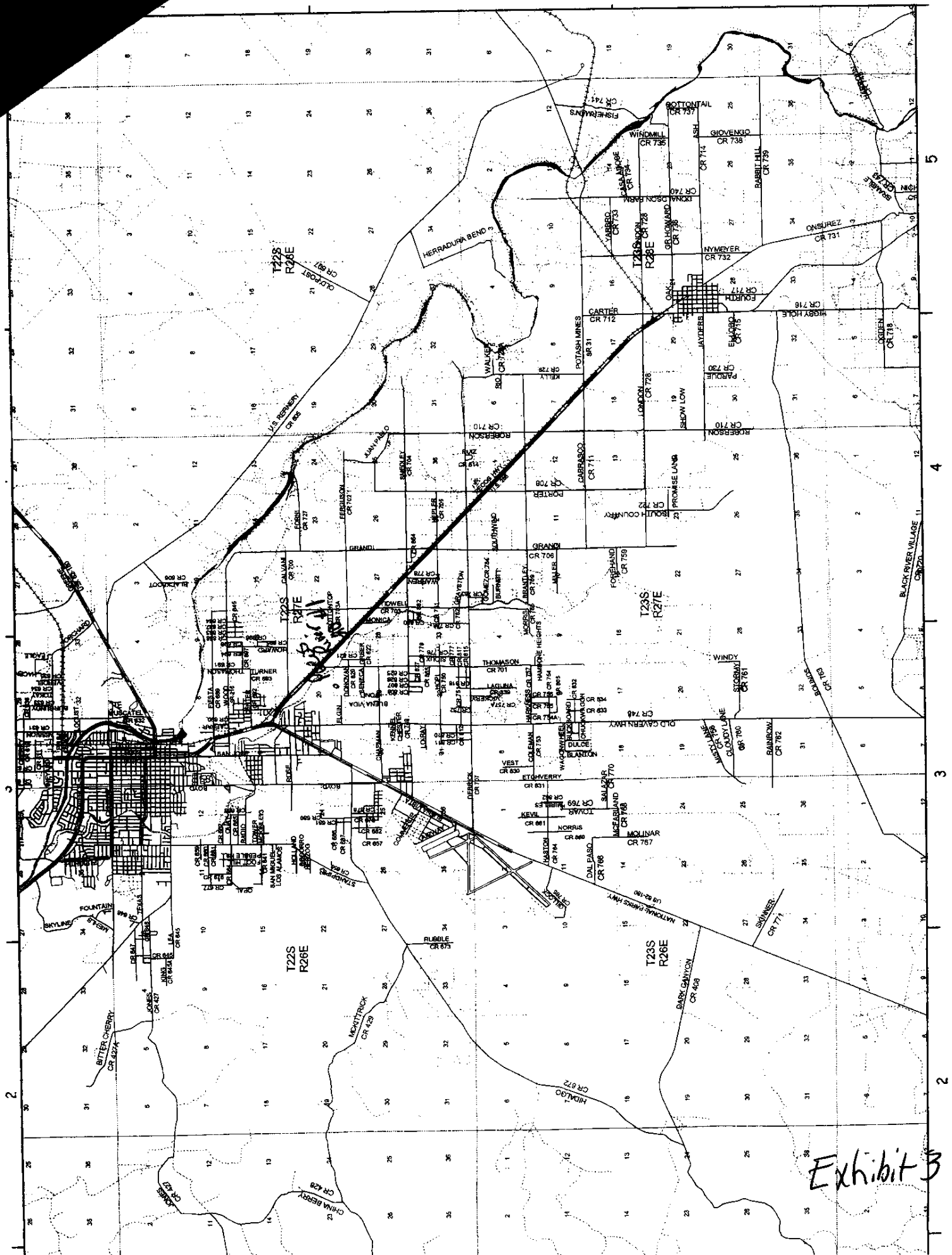

SECTION 20, TOWNSHIP 22 SOUTH, RANGE 27 EAST, NMPM, EDDY COUNTY, NEW MEXICO.

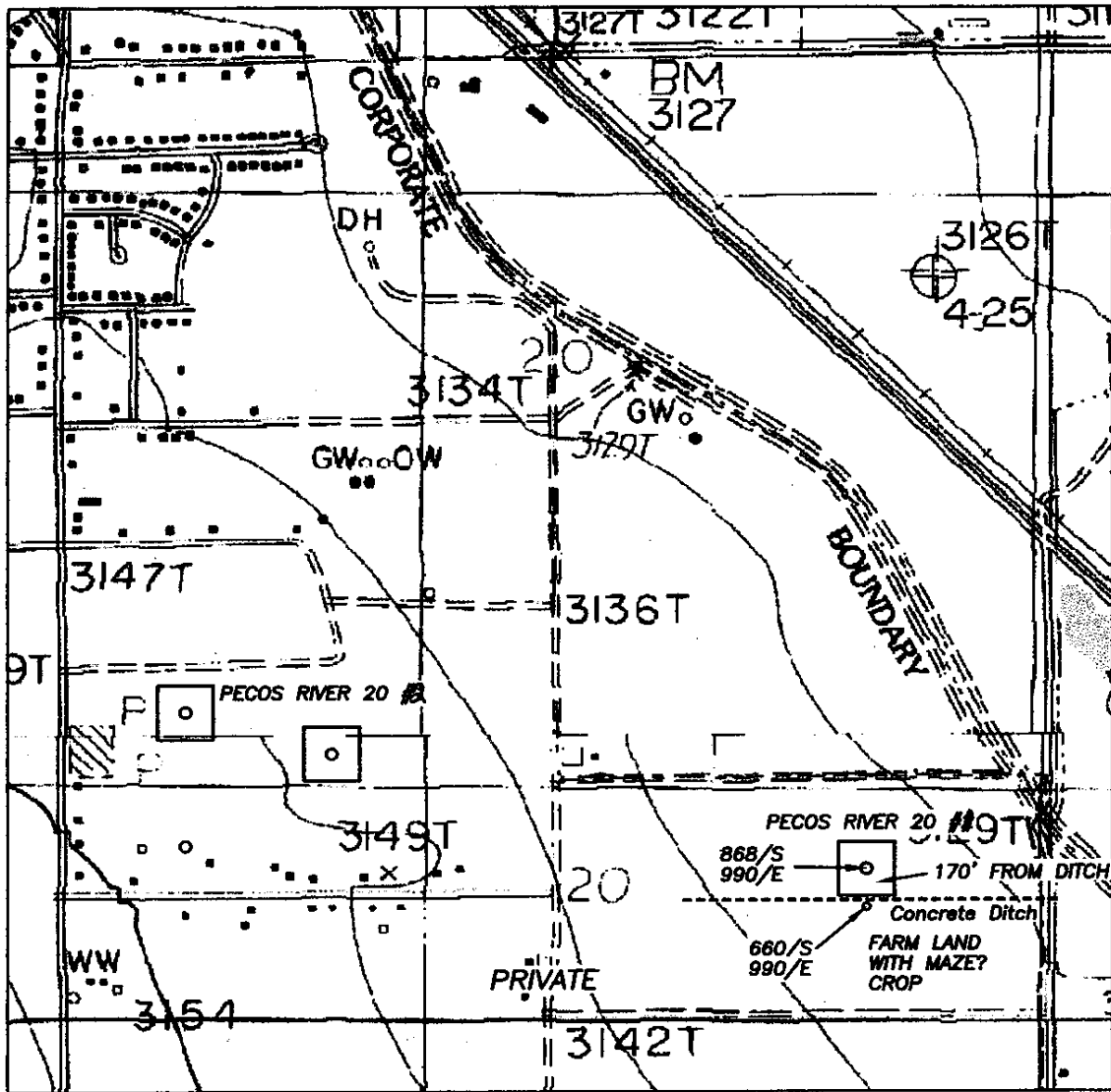
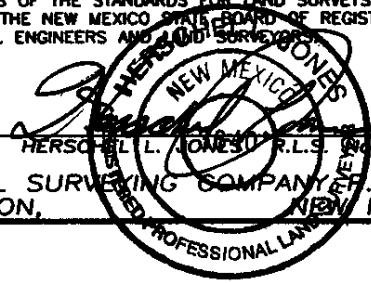

Exhibit 3A



THE PREPARATION OF THIS PLAT AND THE PERFORMANCE OF THE SURVEY UPON WHICH IT IS BASED WERE DONE UNDER MY DIRECTION AND THE PLAT ACCURATELY DEPICTS THE RESULTS OF SAID SURVEY AND MEET THE REQUIREMENTS OF THE STANDARDS FOR LAND SURVEYS IN NEW MEXICO AS ADOPTED BY THE NEW MEXICO STATE BOARD OF REGISTRATION FOR PROFESSIONAL ENGINEERS AND LAND SURVEYORS.



GENERAL SURVEYING COMPANY, P.O. BOX 1928  
LOVINGTON, NEW MEXICO 88260

<b>MEWBOURNE OIL COMPANY</b>	
LEASE ROAD TO ACCESS THE MEWBOURNE PECOS RIVER "20" #1 & 2 WELLS, LOCATED IN SECTION 20, TOWNSHIP 22 SOUTH, RANGE 27 EAST, NMPM, EDDY COUNTY, NEW MEXICO.	
Survey Date: 6/06/2005	Sheet 1 of 1 Sheets
Drawn By: Ed Blevins	W.O. Number
Date: 6/06/05	Scale 1" = 1000' PECOS RIVER

# Mewbourne Oil Company

## Exhibit #5

Well Name | Pecos River 20 #1  
 Footages | 868' FSL & 990' FEL  
 STR | Sec 20-T22S-R27E  
 County | Eddy, County  
 State | New Mexico

Reserve Pit  
 150 x 150'

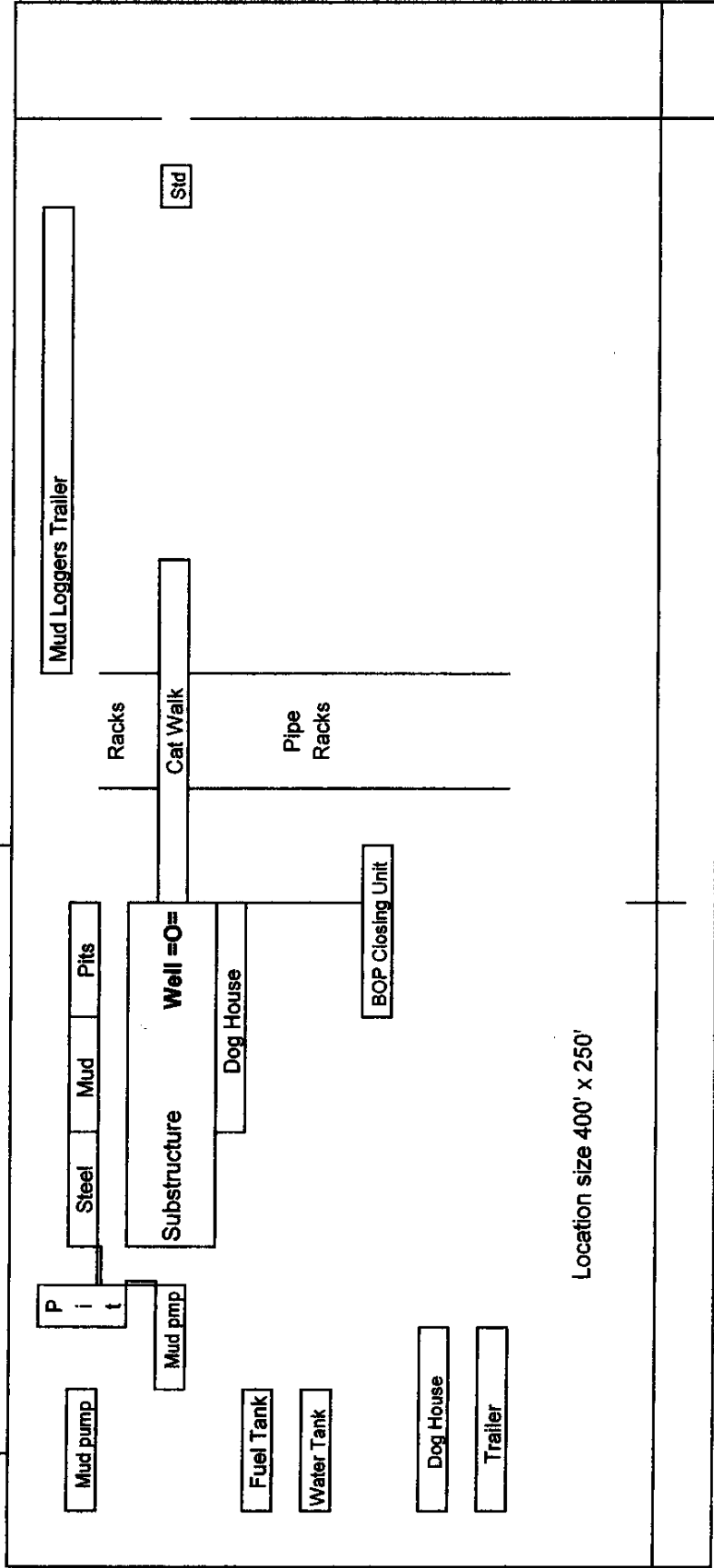

Location size 400' x 250'

Rig Location Schematic

# Proposed Production Facilities Schematic

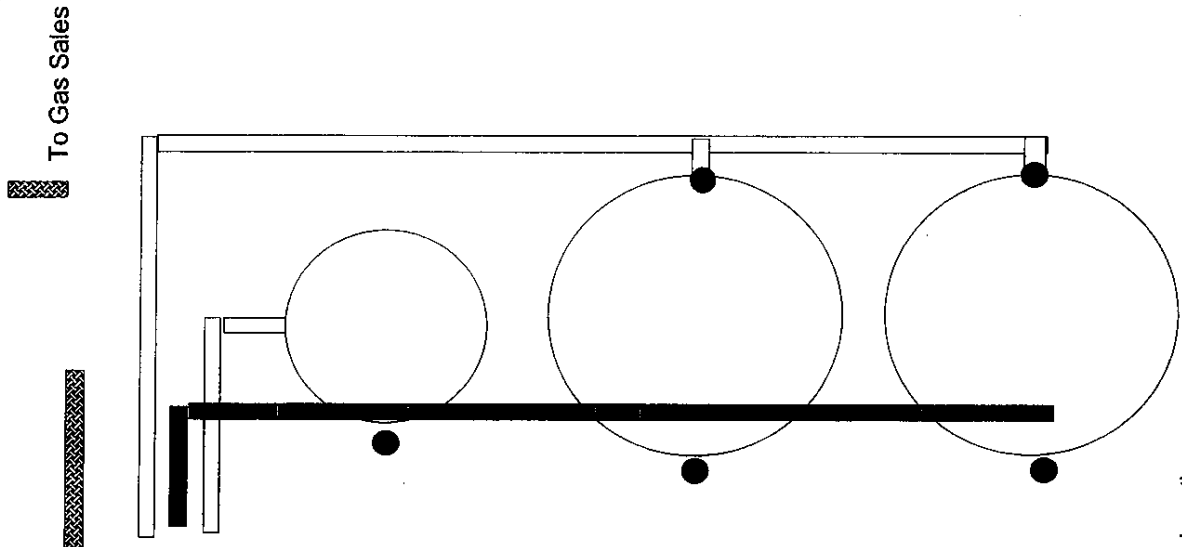

Well

Flow Line

Separation Unit

Water Tank

Stock Tank

Stock Tank

To Gas Sales

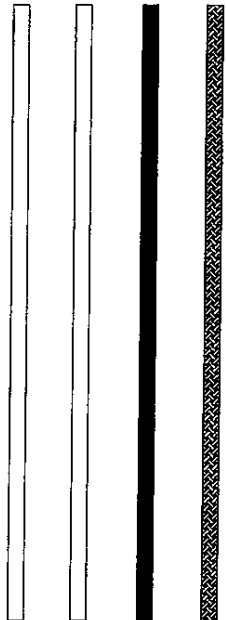

Flow Line  
Water Line  
Oil Dump Line  
Gas Sales Line



Sealing Valve  
Non Sealing Valve

*Newbourne Oil Company*  
Exhibit # 6  
Proposed Production Facilities Schematic

Pecos River 20 #1  
868' FSL & 990' FEL  
Section 20-T22S-R27E  
Eddy County  
New Mexico

### Toxic Effects of Hydrogen Sulfide Poisoning

Hydrogen Sulfide is extremely toxic. The acceptable ceiling concentration for eight-hour exposure is 20 ppm, which is .002% by volume. Hydrogen Sulfide is heavier than air (specific gravity - 1.192) and colorless. It forms an explosive mixture with air between 4.3 and 46.0 percent by volume. Hydrogen Sulfide is almost as toxic as Hydrogen Cyanide and is between five and six times more toxic than Carbon Monoxide. Toxicity data for Hydrogen Sulfide and various other gases are compared below in Table I. Physical effects at various Hydrogen Sulfide levels are shown in Table II.

**Table I**  
Toxicity of Various Gases

Common Name	Chemical Formula	Specific Gravity	Threshold Limit (A)	Hazardous Limit (B)	Lethal Concentration (C)
Hydrogen Cyanide	HCN	0.94	10 ppm	150 ppm/hr	300 ppm
Hydrogen Sulfide	H <sub>2</sub> S	1.18	10 ppm (D) 20 ppm (E)	250 ppm/hr	600 ppm
Sulfur Dioxide	SO <sub>2</sub>	2.21	5 ppm		1000 ppm
Chlorine	CL <sub>2</sub>	2.45	1 ppm	4 ppm/hr	1000 ppm
Carbon Monoxide	CO	0.97	50 ppm	400 ppm/hr	1000 ppm
Carbon Dioxide	CO <sub>2</sub>	1.52	5000 ppm	(5 %)	(10 %)
Methane	CH <sub>4</sub>	0.55	90,000 ppm	(9 %)	Combustible Above 5% in air

- A. **Threshold Limit** - Concentration at which it is believed that all workers may be repeatedly exposed day after day without adverse effects.
- B. **Hazardous Limit** - Concentration that may cause death.
- C. **Lethal Concentration** - Concentration that will cause death with short-term exposure.
- D. **Threshold Limit (10 ppm)** - 1972 ACGIH (American Conference of Governmental Industrial Hygienists).
- E. **Threshold Limit (20 ppm)** - 1966 ANSI acceptable ceiling concentration for eight-hour exposure (based on 40 hour week) is 20 ppm. OSHA Rules and Regulations (Federal Register, Volume 37, No. 202, Part II, dated 10/18/72)

**Table II**  
Physical Effects of Hydrogen Sulfide

Percent (%)	ppm	Physical Effects
0.001	10	Obvious and unpleasant odor
0.002	20	Safe for 8 hrs. exposure
0.01	100	Kills smell in 3-5 minutes; may sting eyes & throat
0.02	200	Kills smell shortly; stings eyes and throat
0.03	300	IDLH (Immediate Danger to Life and Health) Level
0.05	500	Dizziness; breathing ceases in a few minutes
0.07	700	Unconscious quickly; death will result if not rescued
0.10	1000	Unconscious at once; followed by death within minutes

**\* CAUTION:** Hydrogen Sulfide is a colorless and transparent gas and is highly flammable. It is heavier than air and may accumulate in low places.

**Use of Self-Contained Breathing Apparatus**  
(SCBA)

- I. Written procedures shall be prepared covering safe use of respirators in dangerous atmospheric situations, which might be encountered in normal operations or in emergencies. Personnel shall be familiar with these procedures and the available respirators.
- II. Respirators shall be inspected frequently, at random, to insure that they are properly used, cleaned and maintained.
- III. Anyone who may use respirators shall be trained in how to properly seal the face piece. They shall wear respirators in normal air and then in a test atmosphere. **(NOTE: Such items as facial hair (beard or sideburns) and eyeglass temple pieces will not allow a proper seal).** Anyone that may be expected to wear respirators should have these items removed before entering a toxic atmosphere. A special mask must be obtained for anyone who must wear eyeglasses. Contact lenses should not be allowed.
- IV. Maintenance and care of Respirators
  - A. A program of maintenance and care of respirators shall include the following:
    1. Inspection for defects, including leak checks.
    2. Cleaning and disinfecting.
    3. Repair
    4. Storage
  - B. Inspection: Self Contained Breathing Apparatus (SCBA) for emergency use shall be inspected monthly and records maintained for the following:
    1. Fully charged cylinders.
    2. Regulator and warning device operation.
    3. Condition of face piece and connection.
    4. Elastomer or rubber parts shall be stretched or massaged to keep them pliable and prevent deterioration.
  - C. Routinely used respirators shall be collected, cleaned and disinfected as frequently as necessary to insure proper protection is provided.
- V. Persons assigned tasks that require the use of Self Contained Breathing Equipment shall be certified physically fit for breathing equipment usage by the local company physician at least annually.
- VI. Respirators should be worn during the following conditions:
  - A. Any employee who works near the top or on the top of any tank unless tests reveal less than 20 ppm of H<sub>2</sub>S.
  - B. When breaking out any line where H<sub>2</sub>S can reasonably be expected.
  - C. When sampling air in areas to determine if toxic concentrations of H<sub>2</sub>S exist.
  - D. When working in areas where over 20 ppm H<sub>2</sub>S has been detected.
  - E. At any time there is a doubt as to the H<sub>2</sub>S level in the area to be entered.



## **Rescue-First Aid for Hydrogen Sulfide Poisoning**

**DO NOT PANIC !!!!**

**Remain Calm -- THINK**

1. Hold your breath (Do not inhale; stop breathing) and go to Briefing Area.
2. Put on Breathing apparatus.
3. Remove victim(s) to fresh air as quickly as possible. (Go upwind from the source or at right angles to the wind; **NOT** downwind).
4. Briefly apply chest pressure-arm lift method of artificial respiration to clear the victim's lungs and to avoid inhaling any toxic gas directly from the victim's lungs.
5. Provide for prompt transportation to the hospital and continue giving artificial respiration if needed.
6. Hospital(s) or medical facilities need to be informed, beforehand, of the possibility of H<sub>2</sub>S gas poisoning, no matter how remote the possibility.
7. Notify emergency room personnel that the victim(s) have been exposed to H<sub>2</sub>S gas.

Besides basic first aid, everyone on location should have a good working knowledge of artificial respiration, as well as first aid for eyes and skin contact with liquid H<sub>2</sub>S. Everyone needs to master these necessary skills.