

UNITED STATES
DEPARTMENT OF THE INTERIOR
BUREAU OF LAND MANAGEMENT

OCD-ARTESIA

FORM APPROVED
OMB No. 1004-0137
Expires March 31, 2007

SUNDRY NOTICES AND REPORTS ON WELLS

Do not use this form for proposals to drill or reenter an abandoned well. Use Form 3160-3 (APD) for such proposals.

SUBMIT IN TRIPLICATE - Other instructions on page 2.

1. Type of Well <input checked="" type="checkbox"/> Oil Well <input type="checkbox"/> Gas Well <input type="checkbox"/> Other (re-entry)		5. Lease Serial No SH NM-101584 BH NM-101582
2. Name of Operator Yates Petroleum Corporation 025575		6. If Indian, Allottee or Tribe Name Not Applicable
3a. Address 105 South Fourth Street, Artesia, NM 88210	3b. Phone No. (include area code) (575) 748-1471	7. If Unit or CA/Agreement, Name and/o Not Applicable
4. Location of Well (Footage, Sec., T., R., M., or Survey Description) 1100' FSL and 330' FEL, Surface Hole 400' FSL and 330' FWL, Bottom Hole Section 27, T16S-R27E		8. Well Name and No. Mucho Luck BBW Federal Com #2t
		9. API Well No. 30-015-39348
		10. Field and Pool, or Exploratory Area Empire NW Wolfcamp
		11. County or Parish, State Eddy County, New Mexico

12. CHECK THE APPROPRIATE BOX(ES) TO INDICATE NATURE OF NOTICE, REPORT, OR OTHER DATA

TYPE OF SUBMISSION	TYPE OF ACTION			
<input type="checkbox"/> Notice of Intent	<input type="checkbox"/> Acidize	<input type="checkbox"/> Deepen	<input type="checkbox"/> Production (Start/Resume)	<input type="checkbox"/> Water Shut-Off
<input type="checkbox"/> Subsequent Report	<input type="checkbox"/> Alter Casing	<input type="checkbox"/> Fracture Treat	<input type="checkbox"/> Reclamation	<input type="checkbox"/> Well Integrity
<input type="checkbox"/> Final Abandonment Notice	<input type="checkbox"/> Casing Repair	<input type="checkbox"/> New Construction	<input type="checkbox"/> Recomplete	<input type="checkbox"/> Other _____
	<input checked="" type="checkbox"/> Change Plans	<input type="checkbox"/> Plug and Abandon	<input type="checkbox"/> Temporarily Abandon	
	<input type="checkbox"/> Convert to Injection	<input type="checkbox"/> Plug Back	<input type="checkbox"/> Water Disposal	

13. Describe Proposed or Completed Operation: Clearly state all pertinent details, including estimated starting date of any proposed work and approximate duration thereof. If the proposal is to deepen directionally or recompleat horizontally, give subsurface locations and measured and true vertical depths of all pertinent markers and zones. Attach the Bond under which the work will be performed or provide the Bond No. on file with BLM/BIA. Required subsequent reports must be filed within 30 days following completion of the involved operations. If the operation results in a multiple completion or recompleat in a new interval, a Form 3160-4 must be filed once testing has been completed. Final Abandonment Notices must be filed only after all requirements, including reclamation, have been completed, and the operator has determined that the site is ready for final inspection.)

Yates Petroleum Corporation wishes to change the Interim Reclamation Plan
Please see attached Exhibit.

AR Dade 11/16/11
RECEIVED
OCT 25 2011
NMOCD ARTESIA

Thank you.

14. I hereby certify that the foregoing is true and correct

Name (Printed/Typed) Monti Sanders	Title Land Regulatory Technician
Signature <i>Monti Sanders</i>	Date October 5, 2011

THIS SPACE FOR FEDERAL OR STATE-USE

Approved by <i>James A. Brown</i>	Title SAS	Date 10-6-11
Conditions of approval, if any, are attached. Approval of this notice does not warrant or certify that the applicant holds legal or equitable title to those rights in the subject lease which would entitle the applicant to conduct operations thereon.	Office 110	

Title 18 U.S.C. Section 1001, make it a crime for any person knowingly and willfully to make to any department or agency of the United States any false, fictitious or fraudulent statements or representations as to any matter within its jurisdiction.



YATES PETROLEUM CORPORATION
Mucho Luck BBW Federal Com. #2H
Plan for Surface Interim Reclamation
Exhibit F

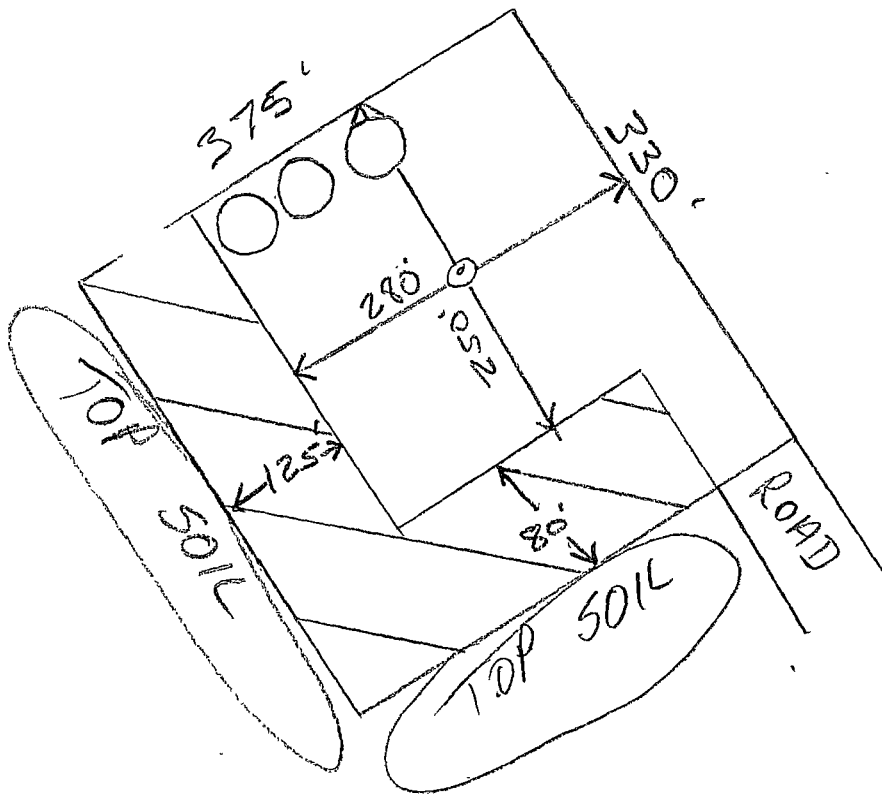

Not to Scale
This plat may
be different
After Final
Reclamation

Possible
Reclaimed
Area