

HIGH CAVEKARST

UNITED STATES
DEPARTMENT OF THE INTERIOR
BUREAU OF LAND MANAGEMENT

APPLICATION FOR PERMIT TO DRILL OR REENTER

5. Lease Serial No.
NMNM 13237 - SL & BHL

TES
8-18-14

6. If Indian, Allottee or Tribe Name

7. If Unit or CA Agreement, Name and No.

1a. Type of work: DRILL REENTER

1b. Type of Well: Oil Well Gas Well Other Single Zone Multiple Zone

8. Lease Name and Well No.
Ruger 31 B3EH Federal #2H

3135557

2. Name of Operator Mewbourne Oil Company

947447

9. API Well No.

30-015-42595

3a. Address PO Box 5270
Hobbs, NM 88241

3b. Phone No. (include area code)
575-393-5905

10. Field and Pool, or Exploratory
Winchester Bone Spring (65010)

4. Location of Well (Report location clearly and in accordance with any State requirements.)*
At surface 2345' FNL & 185' FWL, Sec. 31 T19S R29E
At proposed prod. zone 1850' FNL & 330' FEL, Sec. 31 T19S R29E

11. Sec., T. R. M. or Blk. and Survey or Area
Sec. 31 T19S R29E

14. Distance in miles and direction from nearest town or post office*
15 miles NE of Carlsbad, NM

12. County or Parish
Eddy

13. State
NM

15. Distance from proposed* location to nearest property or lease line, ft. (Also to nearest drig. unit line, if any)
185'

16. No. of acres in lease
NMNM 13237 - 919.88
acres

17. Spacing Unit dedicated to this well
152.40

18. Distance from proposed location* to nearest well, drilling, completed, applied for, on this lease, ft.
139' - Ruger 31 B2EH
Fed #1H

19. Proposed Depth
13,224' - MD
8,907' - TVD

20. BLM/BIA Bond No. on file
NM 1693 nationwide, NMB-000919

21. Elevations (Show whether DF, KDB, RT, GL, etc.)
3297' - GL

22. Approximate date work will start*
06/15/2014

23. Estimated duration
60 days

24. Attachments

The following, completed in accordance with the requirements of Onshore Oil and Gas Order No.1, must be attached to this form:

- 1. Well plat certified by a registered surveyor.
- 2. A Drilling Plan.
- 3. A Surface Use Plan (if the location is on National Forest System Lands, the SUPO must be filed with the appropriate Forest Service Office).
- 4. Bond to cover the operations unless covered by an existing bond on file (see Item 20 above).
- 5. Operator certification
- 6. Such other site specific information and/or plans as may be required by the BLM.

25. Signature

Bradley Bishop

Name (Printed/Typed)
Bradley Bishop

Date
04/30/2014

Title

Approved by (Signature)

Steve Caffey

Name (Printed/Typed)

Date
AUG 13 2014

Title

FIELD MANAGER

Office

CARLSBAD FIELD OFFICE

Application approval does not warrant or certify that the applicant holds legal or equitable title to those rights in the subject lease which would entitle the applicant to conduct operations thereon.

Conditions of approval, if any, are attached.

APPROVAL FOR TWO YEARS

Title 18 U.S.C. Section 1001 and Title 43 U.S.C. Section 1212, make it a crime for any person knowingly and willfully to make to any department or agency of the United States any false, fictitious or fraudulent statements or representations as to any matter within its jurisdiction.

(Continued on page 2)

*(Instructions on page 2)

NM OIL CONSERVATION
ARTESIA DISTRICT

Capitan Controlled Water Basin

AUG 19 2014



RECEIVED

Approval Subject to General Requirements
& Special Stipulations Attached

**SEE ATTACHED FOR
CONDITIONS OF APPROVAL**

Mewbourne Oil Company

PO Box 5270
Hobbs, NM 88241
(575) 393-5905

I hereby certify that I, or someone under my direct supervision, have inspected the drill site and access route proposed herein; that I am familiar with the conditions which currently exist; that I have full knowledge of State and Federal laws applicable to this operation; that the statements made in this APD package are, to the best of my knowledge, true and correct; and that the work associated with the operations proposed herein will be performed in conformity with this APD package and the terms and conditions under which it is approved. I also certify that I, or the company I represent, am responsible for the operations conducted under this application. These statements are subject to the provisions of 18 U.S.C. 1001 for the filing of false statements.

Executed this 30 day of APRIL, 2014.

Name: Robin Terrell

Signature: *Buddy Belp FOR Robin TERRELL*

Position Title: Hobbs District Manager

Address: PO Box 5270, Hobbs NM 88241

Telephone: 575-393-5905

E-mail: myoung@mewbourne.com

DISTRICT I
1625 N. French Dr., Hobbs, NM 88240
Phone: (575) 393-6161 Fax: (575) 393-0720

DISTRICT II
#11 S. First St., Artesia, NM 88210
Phone: (575) 748-1283 Fax: (575) 748-9720

DISTRICT III
1000 Rio Brazos Rd., Aztec, NM 87410
Phone: (505) 334-6178 Fax: (505) 334-6170

DISTRICT IV
1220 S. St. Francis Dr., Santa Fe, NM 87505
Phone: (505) 476-3460 Fax: (505) 476-3462

State of New Mexico
Energy, Minerals & Natural Resources Department
OIL CONSERVATION DIVISION
1220 South St. Francis Dr.
Santa Fe, New Mexico 87505

Form C-102
Revised August 1, 2011
Submit one copy to appropriate
District Office
 AMENDED REPORT

WELL LOCATION AND ACREAGE DEDICATION PLAT

API Number 30-015-42595		Pool Code 65010	Pool Name WINCHESTER BONE SPRING
Property Code 313595	Property Name RUGER 31 B3EH FEDERAL		Well Number 2H
OGRID No. 14744	Operator Name MEWBOURNE OIL COMPANY		Elevation 3297'

Surface Location

UL or lot no.	Section	Township	Range	Lot Idn	Feet from the	North/South line	Feet from the	East/West line	County
2/E	31	19 S	29 E	(2)	2345	NORTH	185	WEST	EDDY

Bottom Hole Location If Different From Surface

UL or lot no.	Section	Township	Range	Lot Idn	Feet from the	North/South line	Feet from the	East/West line	County
H	31	19 S	29 E		1850	NORTH	330	EAST	EDDY

Dedicated Acres 152.40	Joint or Infill	Consolidated Code	Order No.
----------------------------------	-----------------	-------------------	-----------

No allowable will be assigned to this completion until all interests have been consolidated or a non-standard unit has been approved by the division.

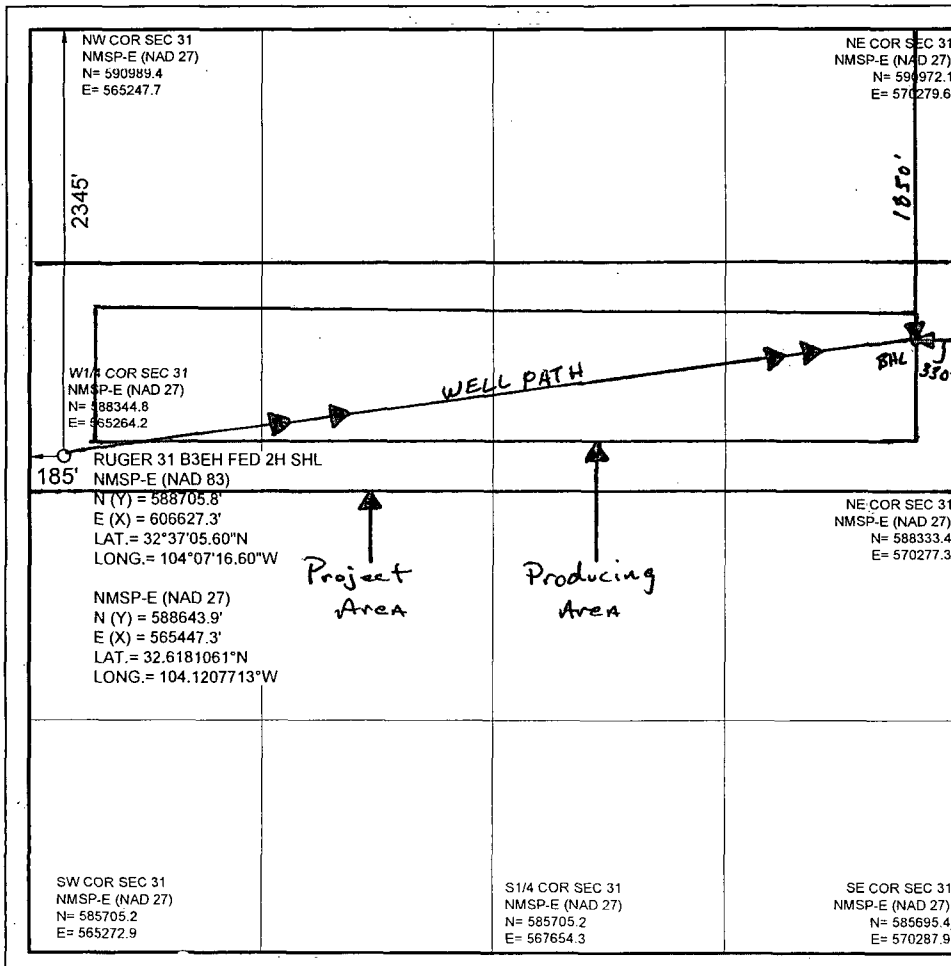

OPERATOR CERTIFICATION
I hereby certify that the information contained herein is true and complete to the best of my knowledge and belief, and that this organization either owns a working interest or unleased mineral interest in the land including the proposed bottom hole location or has a right to drill this well at this location pursuant to a contract with an owner of such a mineral or working interest, or to voluntary pooling agreement or a compulsory pooling order heretofore entered by the division.

Bradley Bishop 4-30-14
Signature Date
BRADLEY BISHOP
Print Name
E-mail Address

SURVEYORS CERTIFICATION
I hereby certify that the well location shown on this plat was plotted from field notes of actual surveys made by me or under my supervision, and that the same is true and correct to the best of my belief.

MARCH 21, 2014
Date of Survey
Signature and Seal of Professional Surveyor
James E. Tompkins
Job No.: WTC49793
JAMES E. TOMPKINS 14729
Certificate Number

SITE LOCATION

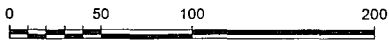
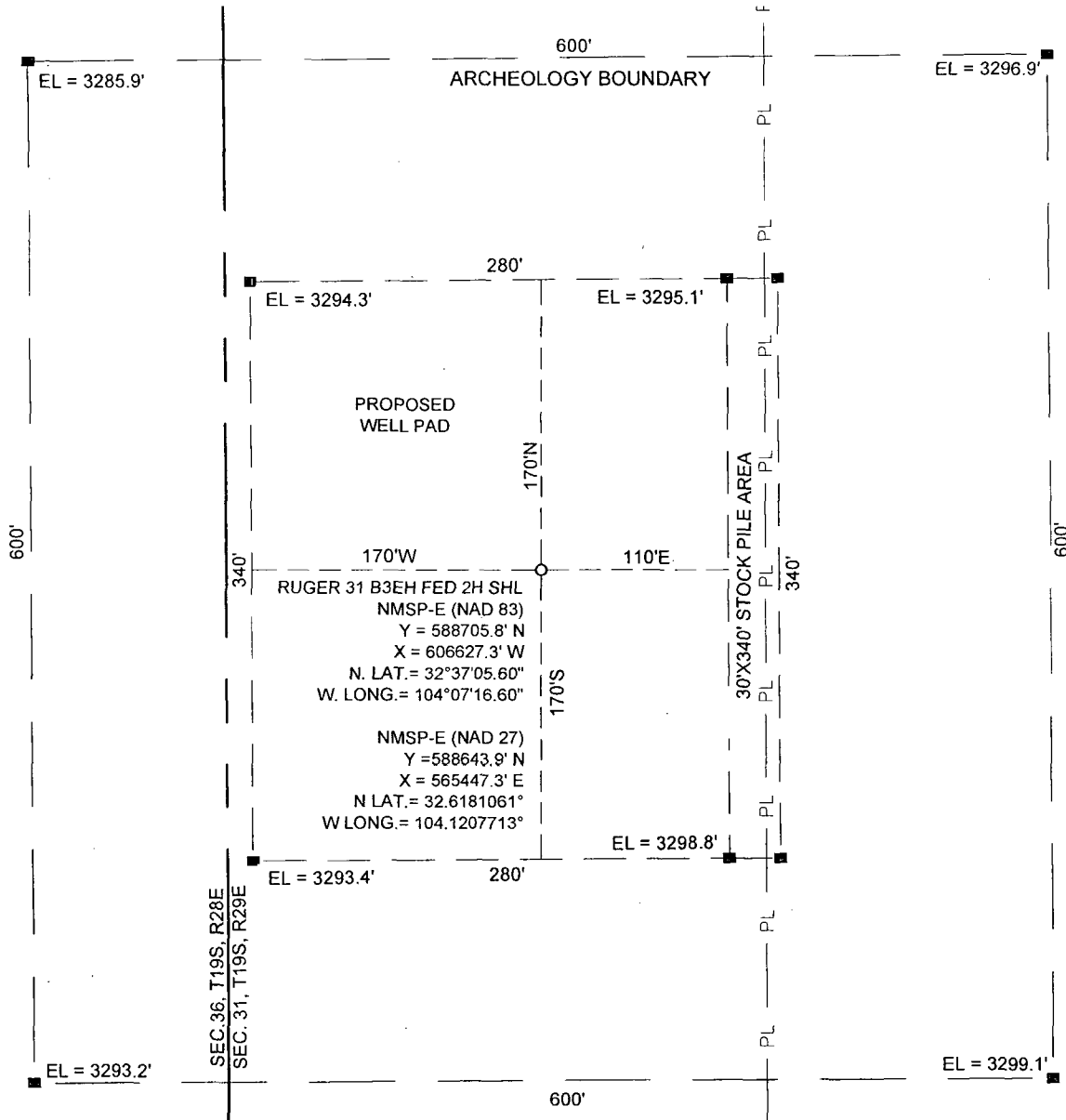

GRAPHIC SCALE 1" = 100'

SECTION 31, T 19 S, R 29 E, N.M.P.M.

COUNTY: EDDY STATE: NM

DESCRIPTION: 2345' FNL & 185' FWL

OPERATOR: MEWBOURNE OIL COMPANY

WELL NAME: RUGER 31 B3EH FEDERAL 2H

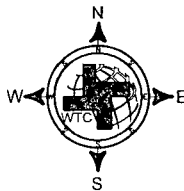

DRIVING DIRECTIONS:

From intersection of Hwy. 285 and Hwy. 62-180. Go Northeast on Hwy. 62-180 for approximately 8.1 miles to Magnum Rd. turn left. Go North on Magnum Rd. 5.8 miles to fork in road. Turn right at fork and go to Intersection of Magnum Rd. and Burton Flat Rd. Go West on Burton Flat Rd. 1.8 miles to Buckskin Rd. Go North on Buckskin Rd. 3.5 miles to a lease road road right, and go east 0.7 mile. The location 0.1 mile South.



WTC, INC.

405 S.W. 1st Street
Andrews, TX 79714
(432) 523-2181

MEWBOURNE OIL COMPANY

"3A"

VICINITY MAP

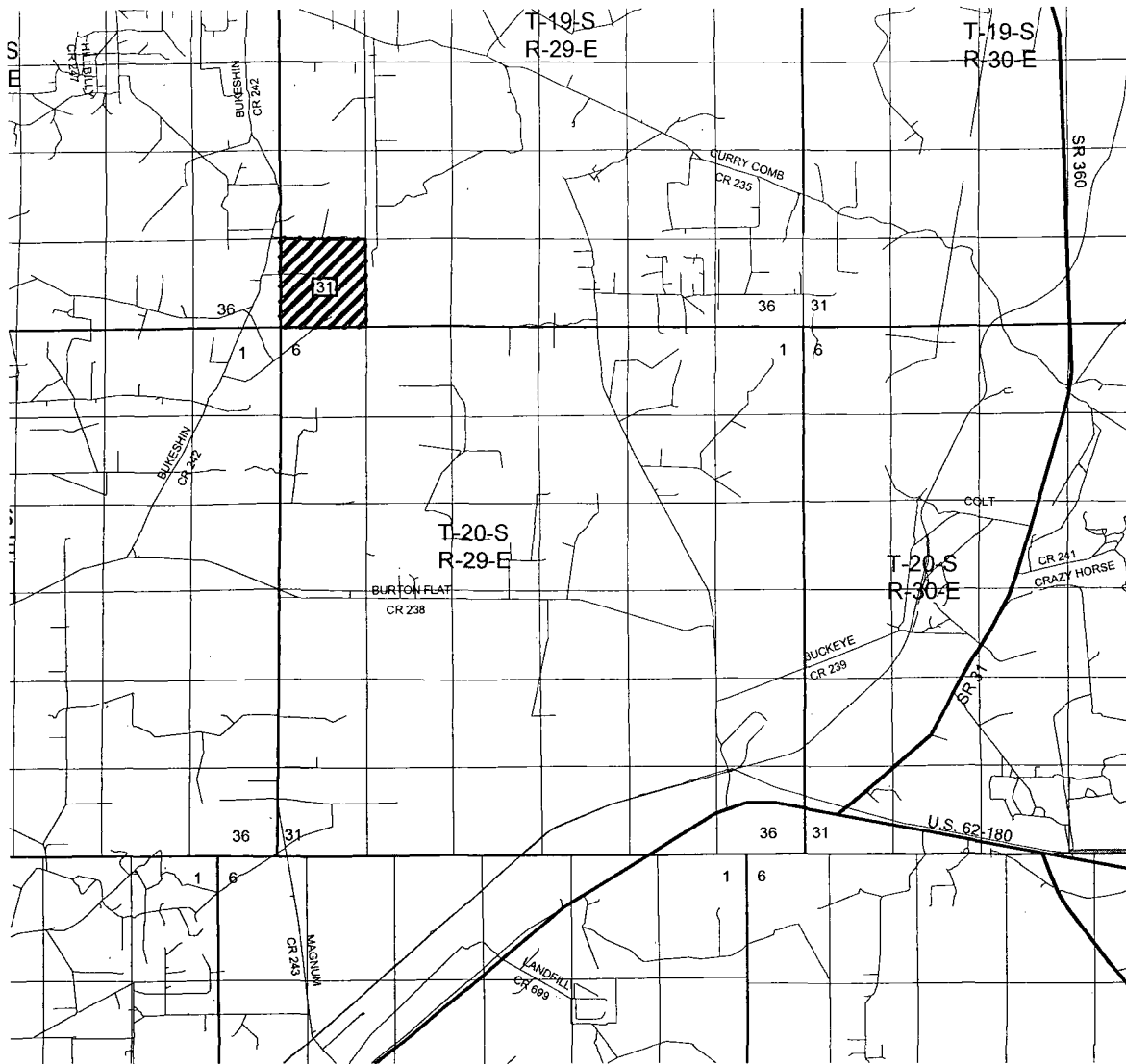

GRAPHIC SCALE OF MILES 1" = 2 MILES

SECTION 31, T 19 S, R 29 E, N.M.P.M.

COUNTY: EDDY STATE: NM

DESCRIPTION: 2345' FNL & 185' FWL

OPERATOR: MEWBOURNE OIL COMPANY

WELL NAME: RUGER 31 B3EH FEDERAL 2H

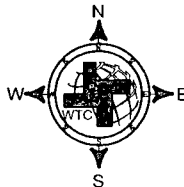

DRIVING DIRECTIONS:

From intersection of Hwy. 285 and Hwy. 62-180. Go Northeast on Hwy. 62-180 for approximately 8.1 miles to Magnum Rd. turn left. Go North on Magnum Rd. 5.8 miles to fork in road. Turn right at fork and go to Intersection of Magnum Rd. and Burton Flat Rd. Go West on Burton Flat Rd. 1.8 miles to Buckskin Rd. Go North on Buckskin Rd. 3.5 miles to a lease road road right, and go east 0.7 mile. The location 0.1 mile South.



WTC, INC.

405 S.W. 1st Street
 Andrews, TX 79714
 (432) 523-2181

MEWBOURNE OIL COMPANY

AERIAL MAP

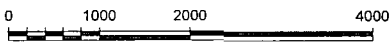
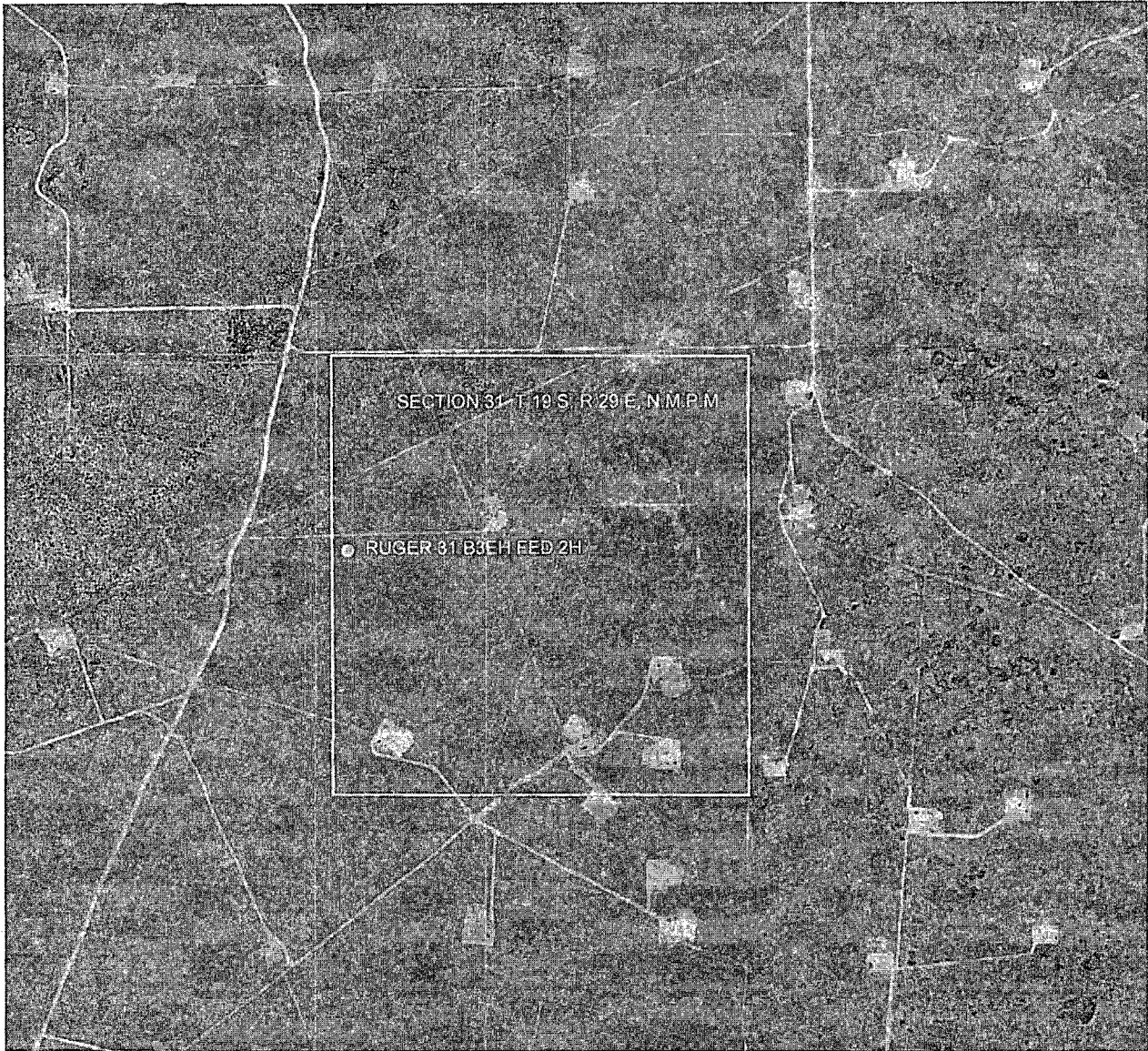

GRAPHIC SCALE 1" = 2000'

SECTION 31, T 19 S, R 29 E, N.M.P.M.

COUNTY: EDDY STATE: NM

DESCRIPTION: 2345' FNL & 185' FWL

OPERATOR: MEWBOURNE OIL COMPANY

WELL NAME: RUGER 31 B3EH FEDERAL 2H

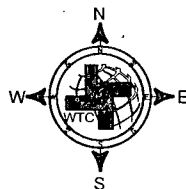

DRIVING DIRECTIONS:

From intersection of Hwy. 285 and Hwy. 62-180. Go Northeast on Hwy. 62-180 for approximately 8.1 miles to Magnum Rd. turn left. Go North on Magnum Rd. 5.8 miles to fork in road. Turn right at fork and go to Intersection of Magnum Rd. and Burton Flat Rd. Go West on Burton Flat Rd. 1.8 miles to Buckskin Rd. Go North on Buckskin Rd. 3.5 miles to a lease road road right, and go east 0.7 mile. The location 0.1 mile South.



W T C, INC.

405 S.W. 1st Street
 Andrews, TX 79714
 (432) 523-2181

MEWBOURNE OIL COMPANY

LOCATION VERIFICATION MAP

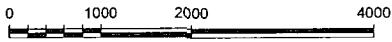
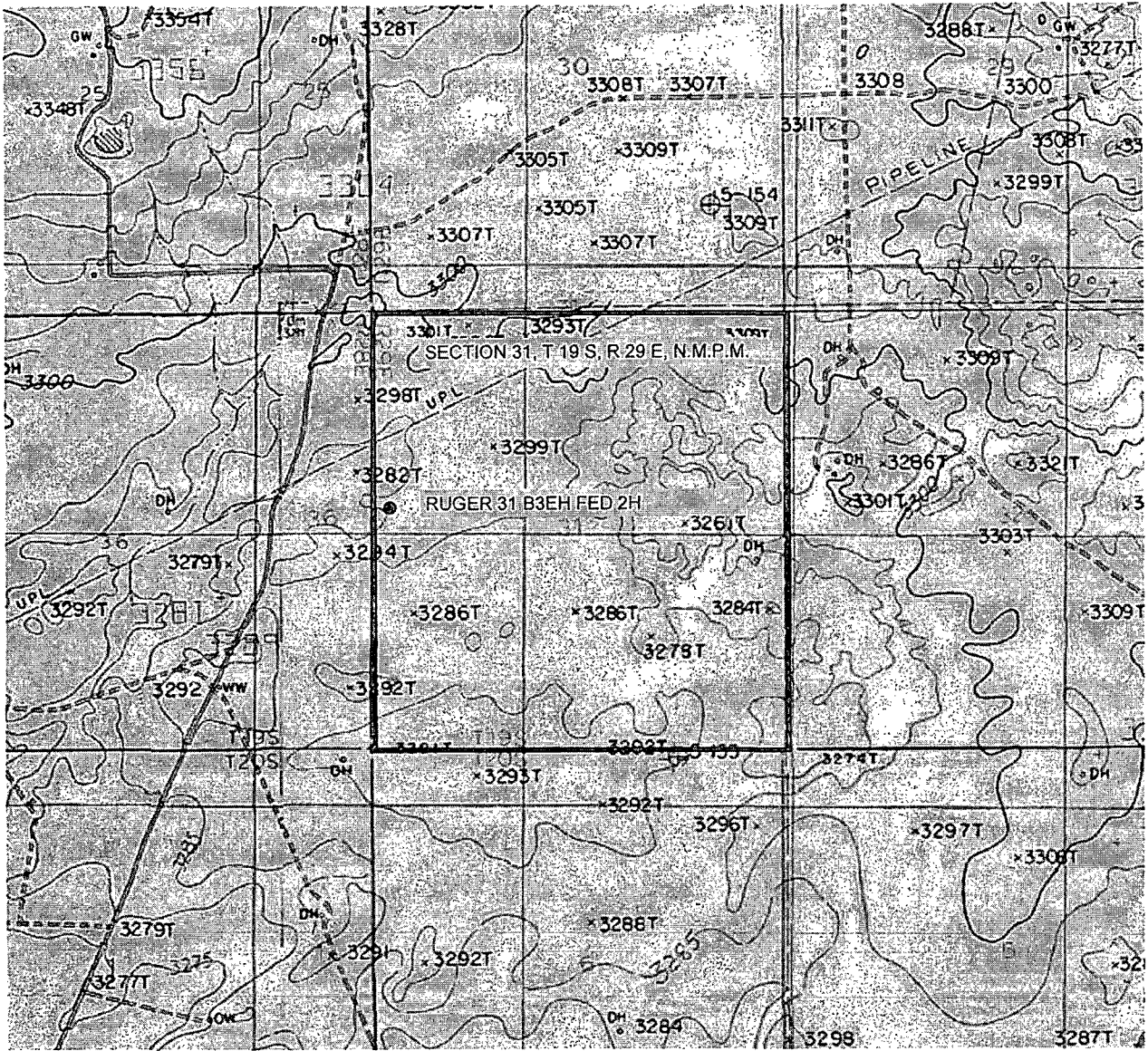

GRAPHIC SCALE 1" = 2000'

SECTION 31, T 19 S, R 29 E, N.M.P.M.

COUNTY: EDDY STATE: NM

DESCRIPTION: 2345' FNL & 185' FWL

OPERATOR: MEWBOURNE OIL COMPANY

WELL NAME: RUGER 31 B3EH FEDERAL 2H

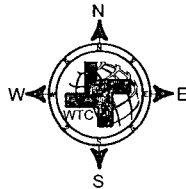

DRIVING DIRECTIONS:

From intersection of Hwy. 285 and Hwy. 62-180. Go Northeast on Hwy. 62-180 for approximately 8.1 miles to Magnum Rd. turn left. Go North on Magnum Rd. 5.8 miles to fork in road. Turn right at fork and go to Intersection of Magnum Rd. and Burton Flat Rd. Go West on Burton Flat Rd. 1.8 miles to Buckskin Rd. Go North on Buckskin Rd. 3.5 miles to a lease road right, and go east 0.7 mile. The location 0.1 mile South.



WTC, INC.

405 S.W. 1st Street
 Andrews, TX 79714
 (432) 523-2181

MEWBOURNE OIL COMPANY

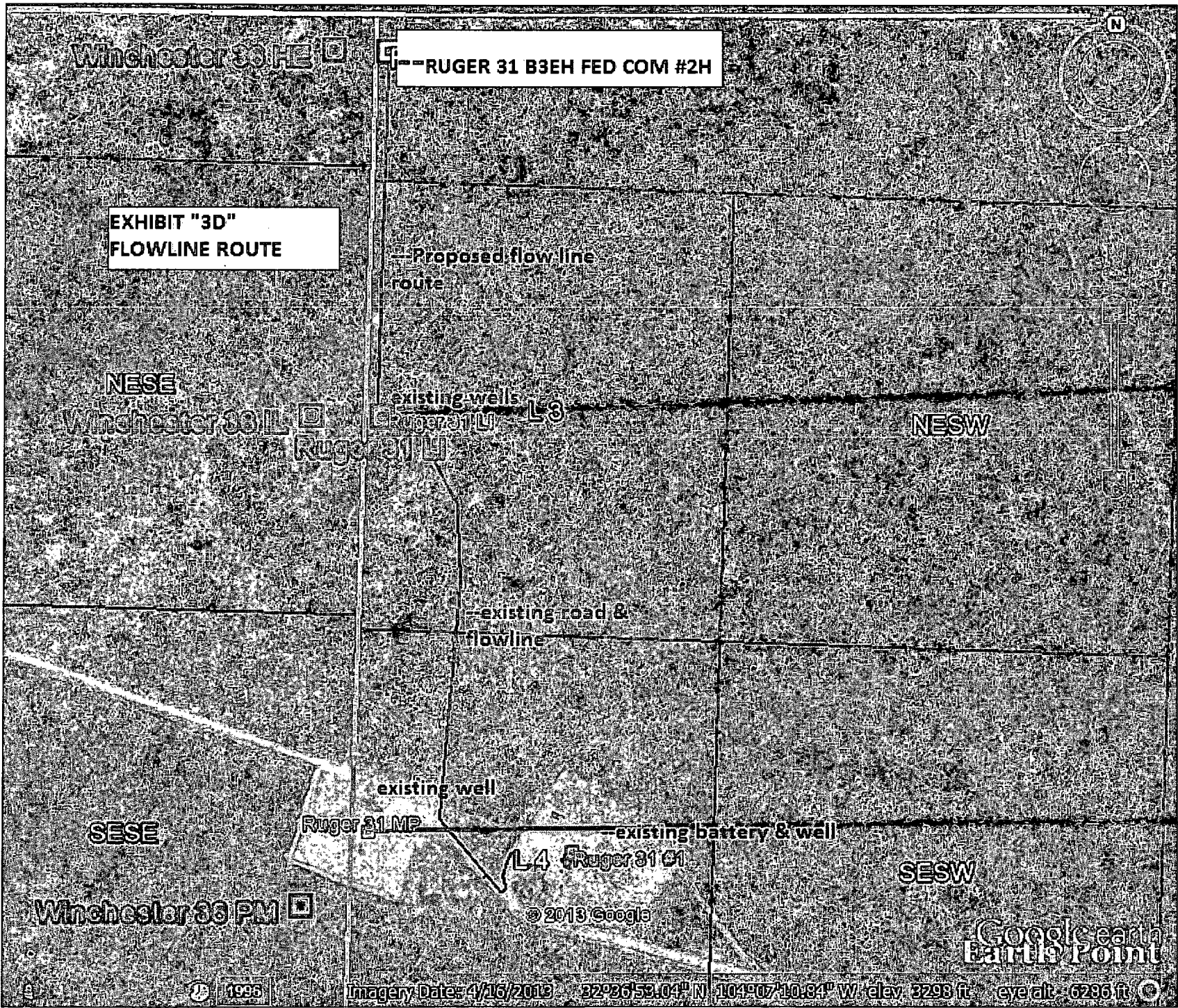

EXHIBIT "3E"

SENECA

L2

Seneca road

WATER 31-82EH

proposed well site
RUGER 31-82EH FED COM #1H

proposed well site
RUGER 31-83EH FED COM #2H

© 2014 Google

Google earth
Earth Point

Image Date: 4/6/2014 11:32:37 AM Scale: 10:1072264 W. elev: 9230 ft. Sea ell: 3389 ft.

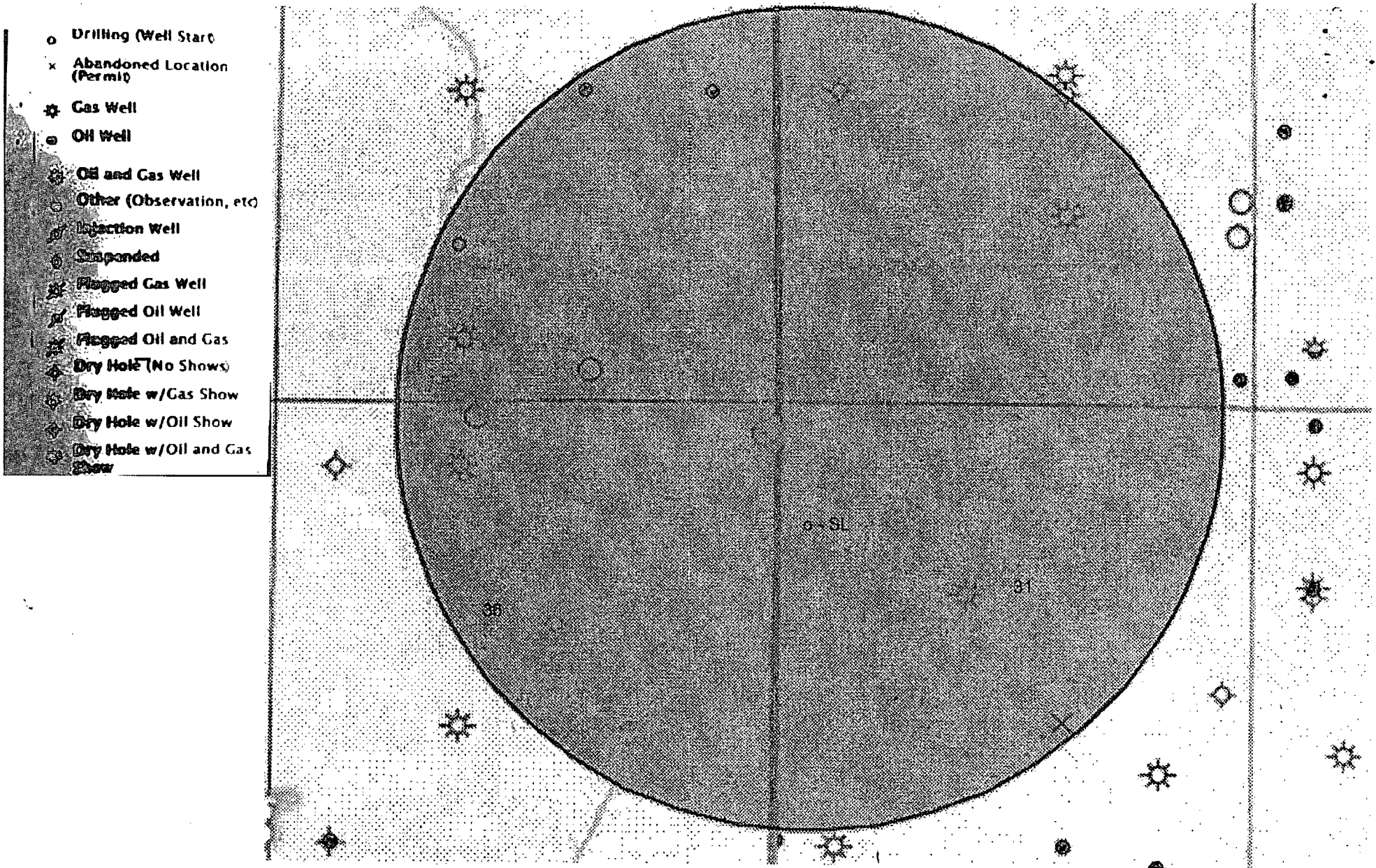

Exhibit "4" - Ruger 31 B3EH Fed Com #2H - SL - 2345' FNL & 185' FWL, Sec. 31 T19S R29E, Eddy Co. NM

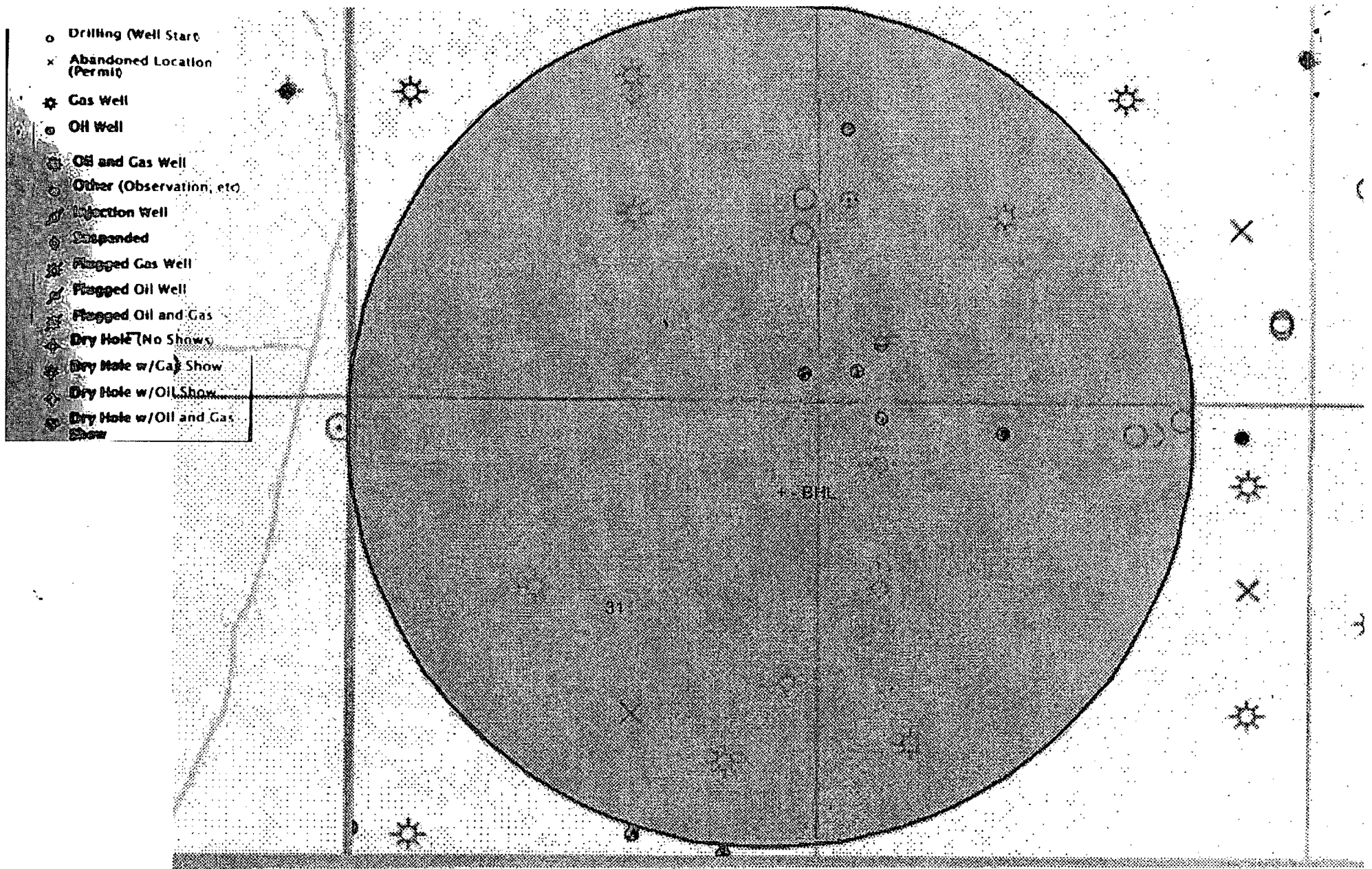

Exhibit "4A" - Ruger 31 B3EH Fed Com #2H - BHL - 1850' FNL & 330' FEL, Sec. 31 T19S R29E, Eddy Co. NM

Drilling Program
Mewbourne Oil Company
 Ruger 31.B3EH Federal #2H
 2345' FNL & 185' FWL
 Sec 31-T19S-R29E
 Eddy County, New Mexico

1. The estimated tops of geological markers are as follows:

Rustler	200'
Top Salt	311'
Base Salt/Tansill	811'
Yates	1009'
Seven Rivers	1307'
Queen	1906'
Capitan	NP
Grayburg	NP
San Andres	NP
*Delaware(Lamar)	3110'
*Bone Spring	4520'
1 st Bone Spring Sand	6750'
2 nd Bone Spring Sand	7530'
3 rd Bone Spring Sand	8605'

← present according to BLM geologist 2/35 at approximately 2135'

2. Estimated depths of anticipated fresh water, oil, or gas:

Water	Fresh water is anticipated at 75' and will be protected by setting surface casing at 225' ^{350'} and cementing to surface.
Hydrocarbons	Oil and gas are anticipated in the above (*) formations. These zones will be protected by casing as necessary.

3. Pressure control equipment:

MOC requests a variance to install 2M diverter after running 20" casing. A 2000# WP Annular will be installed after running 13 3/8" casing. A 3000# WP Double Ram BOP and 3000# WP Annular will be installed after running 9 5/8" & 7" casing strings. Pressure tests will be conducted prior to drilling out under all casing strings. BOP controls will be installed prior to drilling under surface casing and will remain in use until completion of drilling operations. BOPE will be inspected and operated as recommended in Onshore Order #2. A kelly cock and a sub equipped with a full opening valve sized to fit the drill pipe and collars will be available on the rig floor in the open position when the kelly is not in use. Will test the 13 3/8" annular to 1500# and the 9 5/8" & 7" BOPE to 3000# and annular to 1500# with a third party testing company before drilling below each shoe, but will test again, if needed, in 30 days from the 1st test as per BLM Onshore Oil and Gas Order #2.

4. Drilling Program:

MOC proposes to drill a vertical wellbore to 8400' & kick off to horizontal @ 8877' TVD. The well will be drilled to 13224' MD (8907' TVD). See attached directional plan.

5. Proposed casing and cementing program:

A. Casing Program:

Hole Size	Casing	Wt/Ft.	Grade	Depth	Jt Type
26"	20"	94#	K55	0-225'	ST&C
17 1/2"	13 3/8" (new)	48#	H40	0'-1300'	ST&C
12 1/4"	9 5/8" (new)	36#	J55	0'-3000'	LT&C
				External csg packer & DV tool @ 1400'	
8 3/4"	7" (new)	26#	P110	0'-8400' MD	LT&C
8 3/4"	7" (new)	26#	P110	8400'-9146' MD	BT&C
6 1/8"	4 1/2" (new)	13.5#	P110	8946'-13224' MD	LT&C

See COA →

see COA

350

Minimum casing design factors: Collapse 1.125, Burst 1.0, Tensile strength 1.8.

*Subject to availability of casing.

B. Cementing Program:

- i. Surface Casing: 250 sacks Class "C" (35:65:4) light cement w/ salt and LCM additives. Yield at 2.0 cuft/sk. Mix water @ 11.17 gal/sk. 200 sacks Class "C" cement w/ 2% CaCl₂. Yield at 1.34 cuft/sk. Mix water @ 6.33 gal/sk. Cmt circulated to surface w/100% excess. *see COA*
- ii. 1st Intermediate Casing: 500 sacks Class "C" (35:65:4) light cement w/ salt and LCM additives. Yield at 2.0 cuft/sk. Mix water @ 11.17 gal/sk. 200 sacks Class "C" cement w/2% CaCl₂. Yield at 1.34 cuft/sk. Mix water @ 6.33 gal/sk. Cmt circulated to surface w/25% excess. *see COA*
- iii. 2nd Intermediate Casing:
 1st Stage: 200 sacks Class "C" (35:65:4) light cement w/ salt and LCM additives. Yield at 2.0 cuft/sk. Mix water @ 11.17 gal/sk. 200 sacks Class "C" cement w/2% CaCl₂. Yield at 1.34 cuft/sk. Mix water @ 6.33 gal/sk. Cmt circulated to 1400' w/25% excess.
 External casing packer & DV tool @ 1400'.
 2nd Stage: 200 sacks Class "C" (35:65:4) light cement w/ salt and LCM additives. Yield at 2.0 cuft/sk. Mix water @ 11.17 gal/sk. 100 sacks Class "C" cement w/2% CaCl₂. Yield at 1.34 cuft/sk. Mix water @ 6.33 gal/sk. Cmt circulated to surface w/25% excess. *— see COA 3%*
- iii. Production Casing: 475 sacks Class H light cement (35:65:4) with fluid loss, LCM, & salt additives. Yield at 2.12 cuft/sk. Mix water @ 11.32 gal/sk. 400 sacks Class H cement containing fluid loss additives. Yield at 1.18 cuft/sk. Mix water @ 5.22 gal/sk. Cmt calculated to 2800' w/25% excess. *— see COA*
- iv. Production Liner: This will be a Packer/Port completion from TD to 200' inside 7" casing with packer type liner hanger.

*Referring to above blends of light cement: (wt% fly ash : wt% cement : wt% bentonite of the total of first two numbers). Generic names of additives are used since the availability of specific company and products are unknown at this time.

6. Mud Program:

Interval	Type System	Weight	Viscosity	Fluid Loss
0'-225' <i>350'</i>	FW spud mud	8.6-9.0	32-34	NA
225'-1300'	Brine water	10.0-10.2	28-30	NA
1300'-8400'(KOP)	FW	8.5-8.7	28-30	NA
8400'- TD	FW w/Polymer	8.5-8.7	32-35	15

*Visual mud monitoring system shall be in place to detect volume changes indicating loss or gain of circulation fluid volume. Sufficient mud materials will be kept on location at all times to combat abnormal conditions.

7. Evaluation Program:

Samples: 10' samples from surface casing to TD
 Logging: GR, CN & Gyro 100' above KOP (8300') to surface. GR from 8300' to TD.

8. Downhole Conditions

Zones of abnormal pressure:	None anticipated
Zones of lost circulation:	Anticipated in surface and intermediate holes
Maximum bottom hole temperature:	120 degree F
Maximum bottom hole pressure:	8.3 lbs/gal gradient or less ($.43368 \times 8907' = 3863$ psi)

9. Anticipated Starting Date:

Mewbourne Oil Company intends to drill this well as soon as possible after receiving approval with approximately 60 days involved in drilling operations and an additional 20 days involved in completion operations on the project.

Mewbourne Oil Co

Eddy County, New Mexico

Sec 31, T9S, R9E

Ruger 31 B3EH Federal #2H

Wellbore #1

Plan: Design #1

DDC Well Planning Report

21 April, 2014



DDC
Well Planning Report



Database:	EDM 5000.1:Single User.Db	Local Co-ordinate Reference:	Well Ruger 31 B3EH Federal #2H
Company:	Mewbourne Oil Co	TVD Reference:	Well @ 3317.0usft (Patterson #46)
Project:	Eddy County, New Mexico	MD Reference:	Well @ 3317.0usft (Patterson #46)
Site:	Sec.31-T9S, R9E	North Reference:	Grid
Well:	Ruger 31 B3EH Federal #2H	Survey Calculation Method:	Minimum Curvature
Wellbore:	Wellbore #1		
Design:	Design #1		

Project	Eddy County, New Mexico		
Map System:	US State Plane 1927 (Exact solution)	System Datum:	Mean Sea Level
Geo Datum:	NAD 1927 (NADCON CONUS)		
Map Zone:	New Mexico East 3001		

Site	Sec 31, T9S, R9E				
Site Position:		Northing:	586,420.00 usft	Latitude:	32° 36' 43.178 N
From:	Map	Easting:	565,319.60 usft	Longitude:	104° 7' 16.322 W
Position Uncertainty:	0.0 usft	Slot Radius:	13-3/16"	Grid Convergence:	0.11°

Well	Ruger 31 B3EH Federal #2H					
Well Position	+N-S	2,223.9 usft	Northing:	588,643.90 usft	Latitude:	32° 37' 5.182 N
	+E-W	127.7 usft	Easting:	565,447.30 usft	Longitude:	104° 7' 14.777 W
Position Uncertainty		0.0 usft	Wellhead Elevation:	0.0 usft	Ground Level:	3,297.0 usft

Wellbore	Wellbore #1				
-----------------	-------------	--	--	--	--

Magnetics	Model Name	Sample Date	Declination (°)	Dip Angle (°)	Field Strength (nT)
	IGRF2010	4/21/2014	7.52	60.39	48,509

Design	Design #1			
---------------	-----------	--	--	--

Audit Notes:				
Version:	Phase:	PLAN	Tie On Depth:	0.0

Vertical Section:	Depth From (TVD) (usft)	+N-S (usft)	+E-W (usft)	Direction (°)
	0.0	0.0	0.0	81.42

Plan Sections										
Measured Depth (usft)	Inclination (°)	Azimuth (°)	Vertical Depth (usft)	+N-S (usft)	+E-W (usft)	Dogleg Rate (°/100usft)	Build Rate (°/100usft)	Turn Rate (°/100usft)	TFO (°)	Target
0.0	0.00	0.00	0.0	0.0	0.0	0.00	0.00	0.00	0.00	
8,399.5	0.00	0.00	8,399.5	0.0	0.0	0.00	0.00	0.00	0.00	
9,146.0	89.58	81.42	8,877.0	70.7	468.6	12.00	12.00	10.91	81.42	
13,224.0	89.58	81.42	8,907.0	679.3	4,500.9	0.00	0.00	0.00	0.00	PBHL Ruger 31 B3EH

DDC
Well Planning Report



Database:	EDM 5000.1 Single User Db	Local Co-ordinate Reference:	Well Ruger 31:B3EH.Federal #2H
Company:	Mewbourne Oil Co	TVD Reference:	Well @ 3317.0usft (Patterson #46)
Project:	Eddy County, New Mexico	MD Reference:	Well @ 3317.0usft (Patterson #46)
Site:	Sec 31 T9S R9E	North Reference:	Grid
Well:	Ruger 31:B3EH.Federal #2H	Survey Calculation Method:	Minimum Curvature
Wellbore:	Wellbore #1		
Design:	iDesign #1		

Planned Survey

Measured Depth (usft)	Inclination (°)	Azimuth (°)	Vertical Depth (usft)	+N-S (usft)	+E-W (usft)	Vertical Section (usft)	Dogleg Rate (°/100usft)	Build Rate (°/100usft)	Turn Rate (°/100usft)
Curve KOP//Build:12°/100'									
8,399.5	0.00	0.00	8,399.5	0.0	0.0	0.0	0.00	0.00	0.00
8,425.0	3.06	81.42	8,425.0	0.1	0.7	0.7	12.00	12.00	0.00
8,450.0	6.06	81.42	8,449.9	0.4	2.6	2.7	12.00	12.00	0.00
8,475.0	9.06	81.42	8,474.7	0.9	5.9	6.0	12.00	12.00	0.00
8,500.0	12.06	81.42	8,499.3	1.6	10.4	10.5	12.00	12.00	0.00
8,525.0	15.06	81.42	8,523.6	2.4	16.2	16.4	12.00	12.00	0.00
8,550.0	18.06	81.42	8,547.5	3.5	23.3	23.5	12.00	12.00	0.00
8,575.0	21.06	81.42	8,571.1	4.8	31.5	31.9	12.00	12.00	0.00
8,600.0	24.06	81.42	8,594.2	6.2	41.0	41.5	12.00	12.00	0.00
8,625.0	27.06	81.42	8,616.7	7.8	51.7	52.3	12.00	12.00	0.00
8,650.0	30.06	81.42	8,638.7	9.6	63.5	64.2	12.00	12.00	0.00
8,675.0	33.06	81.42	8,660.0	11.5	76.4	77.3	12.00	12.00	0.00
8,700.0	36.06	81.42	8,680.6	13.7	90.5	91.5	12.00	12.00	0.00
8,725.0	39.06	81.42	8,700.4	15.9	105.5	106.7	12.00	12.00	0.00
8,750.0	42.06	81.42	8,719.4	18.4	121.6	123.0	12.00	12.00	0.00
8,775.0	45.06	81.42	8,737.5	20.9	138.6	140.2	12.00	12.00	0.00
8,800.0	48.06	81.42	8,754.7	23.6	156.6	158.4	12.00	12.00	0.00
8,825.0	51.06	81.42	8,770.9	26.5	175.4	177.4	12.00	12.00	0.00
8,850.0	54.06	81.42	8,786.1	29.4	195.0	197.2	12.00	12.00	0.00
8,875.0	57.06	81.42	8,800.2	32.5	215.4	217.8	12.00	12.00	0.00
8,900.0	60.06	81.42	8,813.2	35.7	236.5	239.2	12.00	12.00	0.00
8,925.0	63.06	81.42	8,825.2	39.0	258.2	261.1	12.00	12.00	0.00
8,950.0	66.06	81.42	8,835.9	42.3	280.5	283.7	12.00	12.00	0.00
8,975.0	69.06	81.42	8,845.4	45.8	303.4	306.8	12.00	12.00	0.00
9,000.0	72.06	81.42	8,853.8	49.3	326.7	330.4	12.00	12.00	0.00
9,025.0	75.06	81.42	8,860.8	52.9	350.4	354.4	12.00	12.00	0.00
9,050.0	78.06	81.42	8,866.6	56.5	374.4	378.7	12.00	12.00	0.00
9,075.0	81.06	81.42	8,871.2	60.2	398.8	403.3	12.00	12.00	0.00
9,100.0	84.06	81.42	8,874.4	63.9	423.3	428.1	12.00	12.00	0.00
9,125.0	87.06	81.42	8,876.3	67.6	447.9	453.0	12.00	12.00	0.00
End of Curve @ 9146' MD / 89.58° Inc. / 8877' TVD									
9,146.0	89.58	81.42	8,877.0	70.7	468.6	473.9	12.00	12.00	0.00
9,200.0	89.58	81.42	8,877.3	78.8	522.1	528.0	0.00	0.00	0.00
9,300.0	89.58	81.42	8,878.1	93.7	620.9	628.0	0.00	0.00	0.00
9,400.0	89.58	81.42	8,878.8	108.6	719.8	728.0	0.00	0.00	0.00
9,500.0	89.58	81.42	8,879.6	123.6	818.7	828.0	0.00	0.00	0.00
9,600.0	89.58	81.42	8,880.3	138.5	917.6	928.0	0.00	0.00	0.00
9,700.0	89.58	81.42	8,881.0	153.4	1,016.4	1,027.9	0.00	0.00	0.00
9,800.0	89.58	81.42	8,881.8	168.3	1,115.3	1,127.9	0.00	0.00	0.00
9,900.0	89.58	81.42	8,882.5	183.3	1,214.2	1,227.9	0.00	0.00	0.00
10,000.0	89.58	81.42	8,883.2	198.2	1,313.1	1,327.9	0.00	0.00	0.00
10,100.0	89.58	81.42	8,884.0	213.1	1,411.9	1,427.9	0.00	0.00	0.00
10,200.0	89.58	81.42	8,884.7	228.0	1,510.8	1,527.9	0.00	0.00	0.00
10,300.0	89.58	81.42	8,885.5	243.0	1,609.7	1,627.9	0.00	0.00	0.00
10,400.0	89.58	81.42	8,886.2	257.9	1,708.6	1,727.9	0.00	0.00	0.00
10,500.0	89.58	81.42	8,886.9	272.8	1,807.5	1,827.9	0.00	0.00	0.00
10,600.0	89.58	81.42	8,887.7	287.7	1,906.3	1,927.9	0.00	0.00	0.00
10,700.0	89.58	81.42	8,888.4	302.7	2,005.2	2,027.9	0.00	0.00	0.00
10,800.0	89.58	81.42	8,889.1	317.6	2,104.1	2,127.9	0.00	0.00	0.00
10,900.0	89.58	81.42	8,889.9	332.5	2,203.0	2,227.9	0.00	0.00	0.00
11,000.0	89.58	81.42	8,890.6	347.4	2,301.8	2,327.9	0.00	0.00	0.00
11,100.0	89.58	81.42	8,891.3	362.3	2,400.7	2,427.9	0.00	0.00	0.00

DDC
Well Planning Report



Database:	EDM 5000.1 Single User Db	Local Co-ordinate Reference:	Well Ruger 31 B3EH Federal #2H
Company:	Mewbourne Oil Co	TVD Reference:	Well @ 3317.0usft (Patterson #46)
Project:	Eddy County, New Mexico	MD Reference:	Well @ 3317.0usft (Patterson #46)
Site:	Sec 31 T9S R9E	North Reference:	Grid
Well:	Ruger 31 B3EH Federal #2H	Survey Calculation Method:	Minimum Curvature
Wellbore:	Wellbore #1		
Design:	Design #1		

Planned Survey

Measured Depth (usft)	Inclination (°)	Azimuth (°)	Vertical Depth (usft)	+N/-S (usft)	+E/-W (usft)	Vertical Section (usft)	Dogleg Rate (°/100usft)	Build Rate (°/100usft)	Turn Rate (°/100usft)
11,200.0	89.58	81.42	8,892.1	377.3	2,499.6	2,527.9	0.00	0.00	0.00
11,300.0	89.58	81.42	8,892.8	392.2	2,598.5	2,627.9	0.00	0.00	0.00
11,400.0	89.58	81.42	8,893.6	407.1	2,697.4	2,727.9	0.00	0.00	0.00
11,500.0	89.58	81.42	8,894.3	422.0	2,796.2	2,827.9	0.00	0.00	0.00
11,600.0	89.58	81.42	8,895.0	437.0	2,895.1	2,927.9	0.00	0.00	0.00
11,700.0	89.58	81.42	8,895.8	451.9	2,994.0	3,027.9	0.00	0.00	0.00
11,800.0	89.58	81.42	8,896.5	466.8	3,092.9	3,127.9	0.00	0.00	0.00
11,900.0	89.58	81.42	8,897.2	481.7	3,191.7	3,227.9	0.00	0.00	0.00
12,000.0	89.58	81.42	8,898.0	496.7	3,290.6	3,327.9	0.00	0.00	0.00
12,100.0	89.58	81.42	8,898.7	511.6	3,389.5	3,427.9	0.00	0.00	0.00
12,200.0	89.58	81.42	8,899.5	526.5	3,488.4	3,527.9	0.00	0.00	0.00
12,300.0	89.58	81.42	8,900.2	541.4	3,587.2	3,627.9	0.00	0.00	0.00
12,400.0	89.58	81.42	8,900.9	556.4	3,686.1	3,727.9	0.00	0.00	0.00
12,500.0	89.58	81.42	8,901.7	571.3	3,785.0	3,827.9	0.00	0.00	0.00
12,600.0	89.58	81.42	8,902.4	586.2	3,883.9	3,927.9	0.00	0.00	0.00
12,700.0	89.58	81.42	8,903.1	601.1	3,982.8	4,027.9	0.00	0.00	0.00
12,800.0	89.58	81.42	8,903.9	616.1	4,081.6	4,127.9	0.00	0.00	0.00
12,900.0	89.58	81.42	8,904.6	631.0	4,180.5	4,227.9	0.00	0.00	0.00
13,000.0	89.58	81.42	8,905.3	645.9	4,279.4	4,327.9	0.00	0.00	0.00
13,100.0	89.58	81.42	8,906.1	660.8	4,378.3	4,427.9	0.00	0.00	0.00
13,200.0	89.58	81.42	8,906.8	675.8	4,477.1	4,527.9	0.00	0.00	0.00
PBHL @ 13224' MD / 8907' TVD									
13,224.0	89.58	81.42	8,907.0	679.3	4,500.9	4,551.8	0.00	0.00	0.00

Design Targets

Target Name

hit/miss target	Dip Angle (°)	Dip Dir. (°)	TVD (usft)	+N/-S (usft)	+E/-W (usft)	Northing (usft)	Easting (usft)	Latitude	Longitude
- Shape									
PBHL Ruger 31 B3EH F	0.00	0.00	8,907.0	679.3	4,500.9	589,323.23	569,948.17	32° 37' 11.812 N	104° 6' 22.135 W
- plan hits target center									
- Point									

Plan Annotations

Measured Depth (usft)	Vertical Depth (usft)	Local Coordinates		Comment
		+N/-S (usft)	+E/-W (usft)	
8,399.5	8,399.5	0.0	0.0	Curve KOP / Build 12°/100'
9,146.0	8,877.0	70.7	468.6	End of Curve @ 9146' MD / 89.58° Inc. / 8877' TVD
13,224.0	8,907.0	679.3	4,500.9	PBHL @ 13224' MD / 8907' TVD

Mewbourne Oil Company

Eddy County, New Mexico
Sec 31, T9S, R9E
Ruger 31 B3EH Federal #2H
Design #1

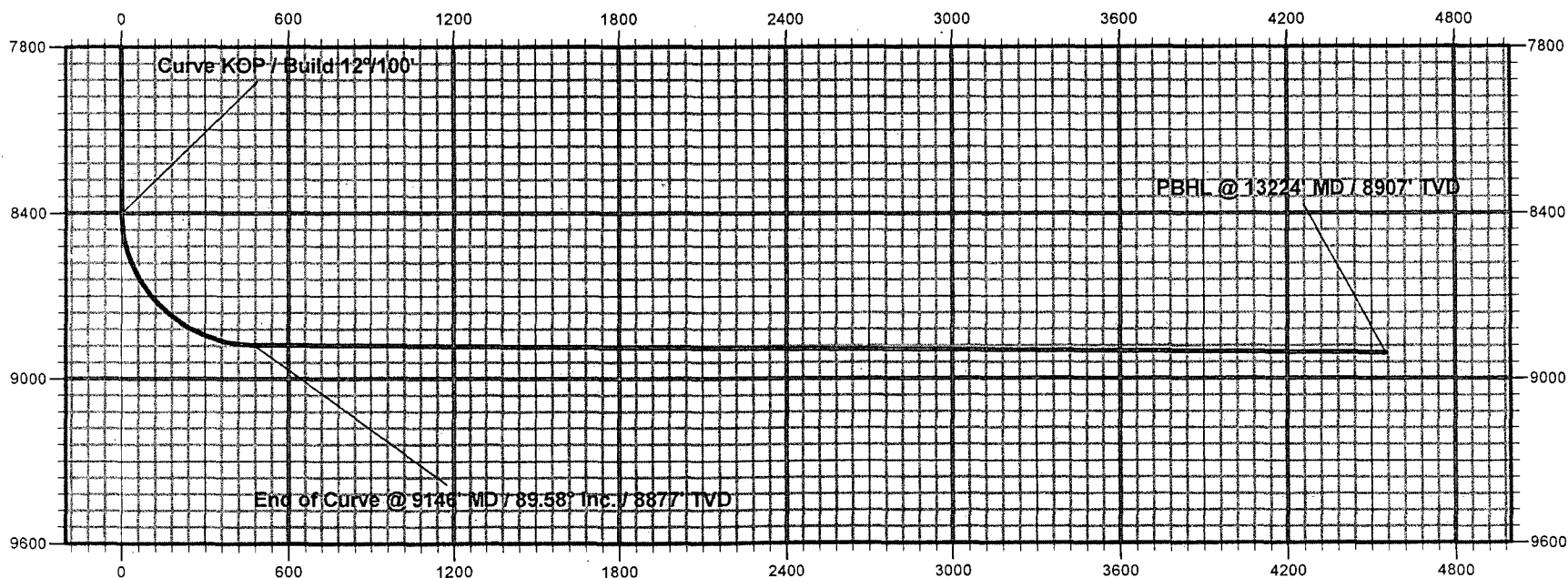
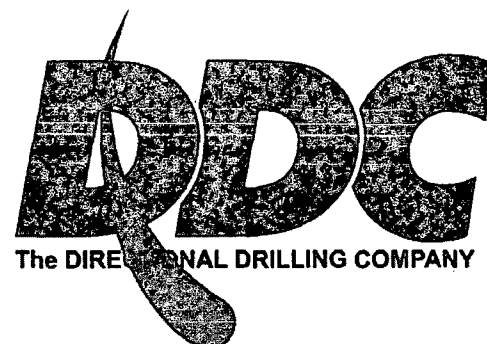

Vertical Section at 81.42° (600 usft/in)

Mewbourne Oil Co

Eddy County, New Mexico

Sec 31, T9S, R9E

Ruger 31 B3EH Federal #2H

Design #1

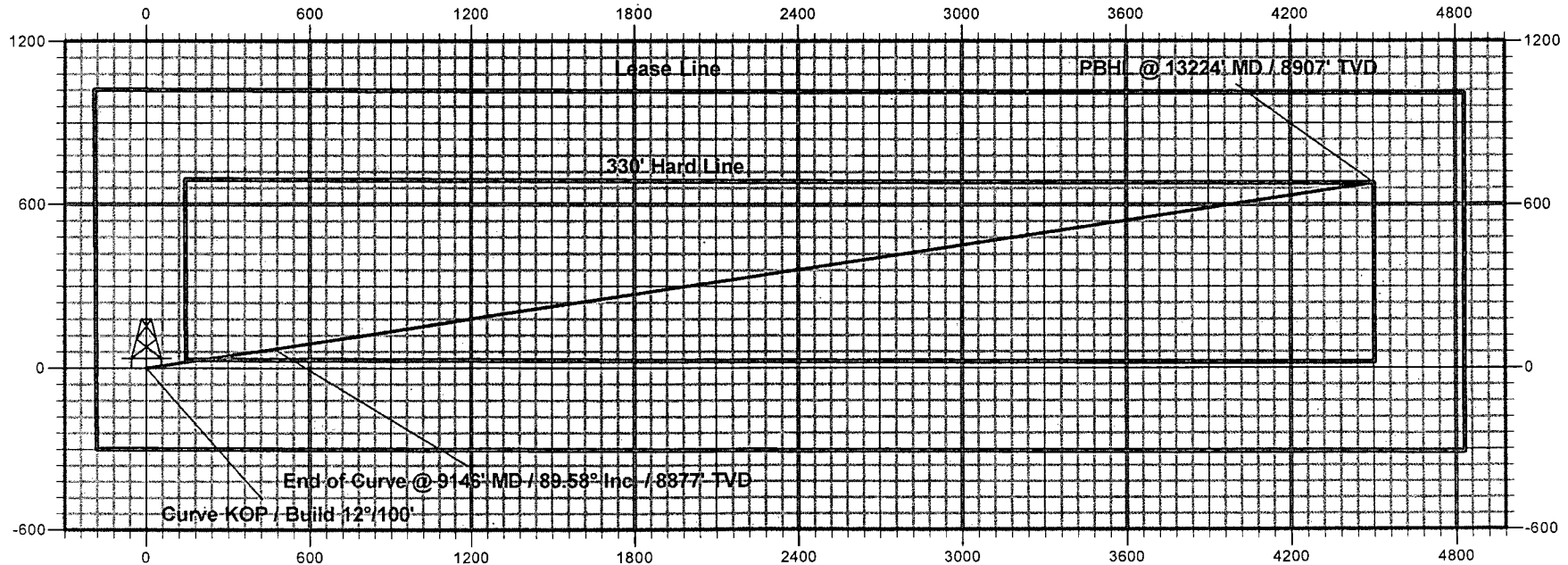
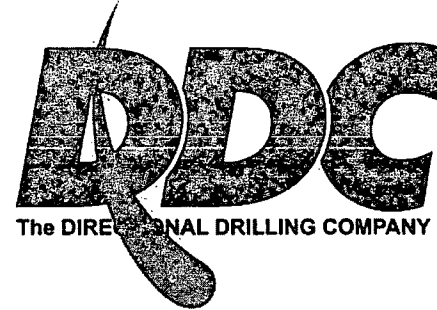

13 5/8" 2M BOPE & Closed Loop Equipment Schematic

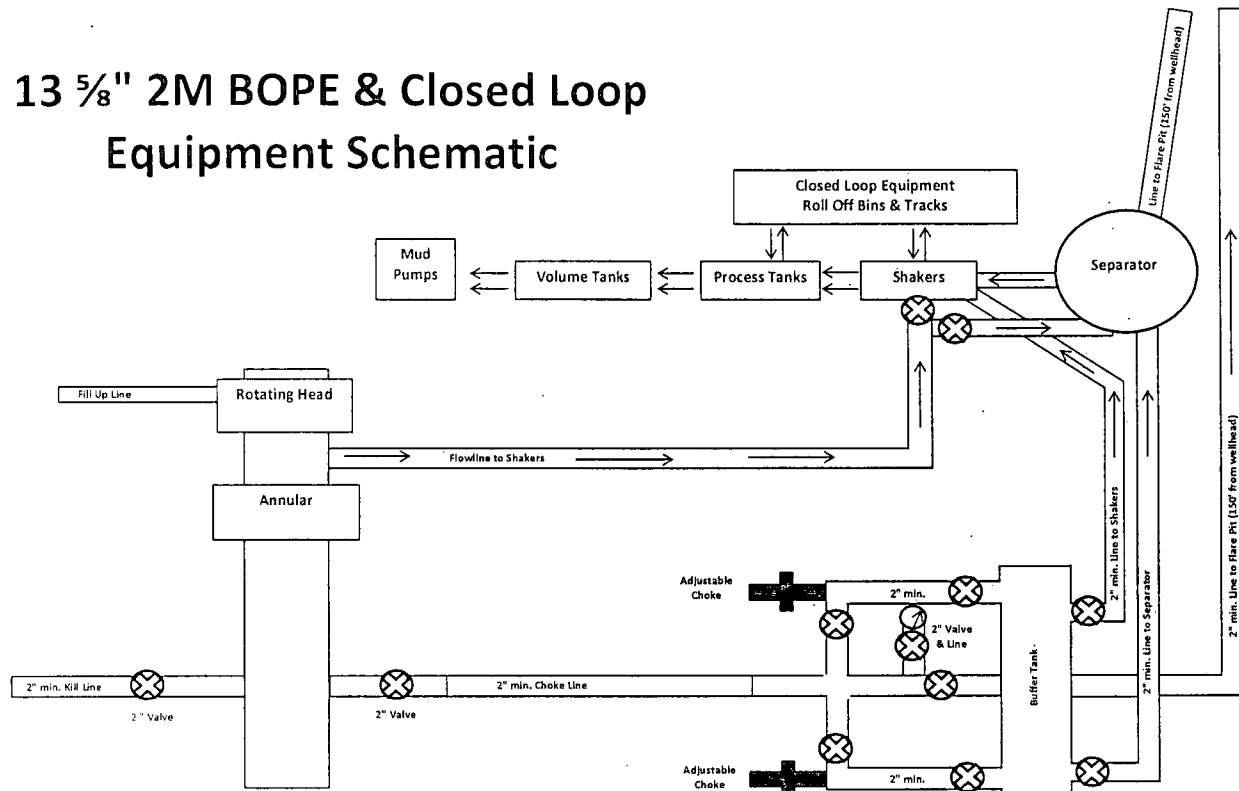

Exhibit 2A
Ruger 31 B3EH Fed Com #2H

11" 3M BOPE & Closed Loop Equipment Schematic

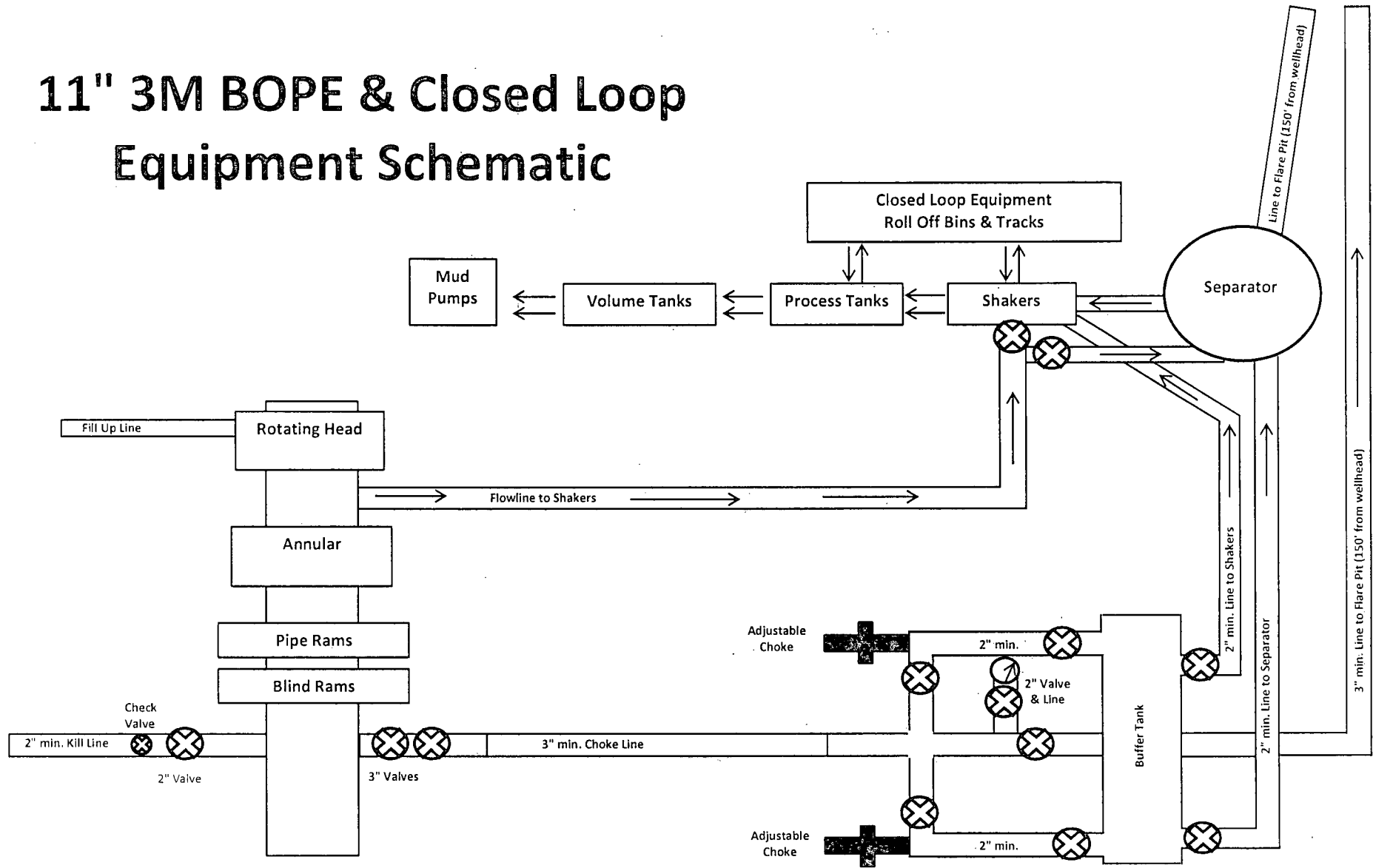

Exhibit 2
Ruger 31 B3EH Fed Com #2H

Note: All valves & lines on choke manifold are 3" unless otherwise noted. Exact manifold configuration may vary.

Notes Regarding Blowout Preventer

Mewbourne Oil Company

Ruger 31 B3EH Fed #2H

2345' FNL & 185' FWL

Sec. 31-T19S-R29E



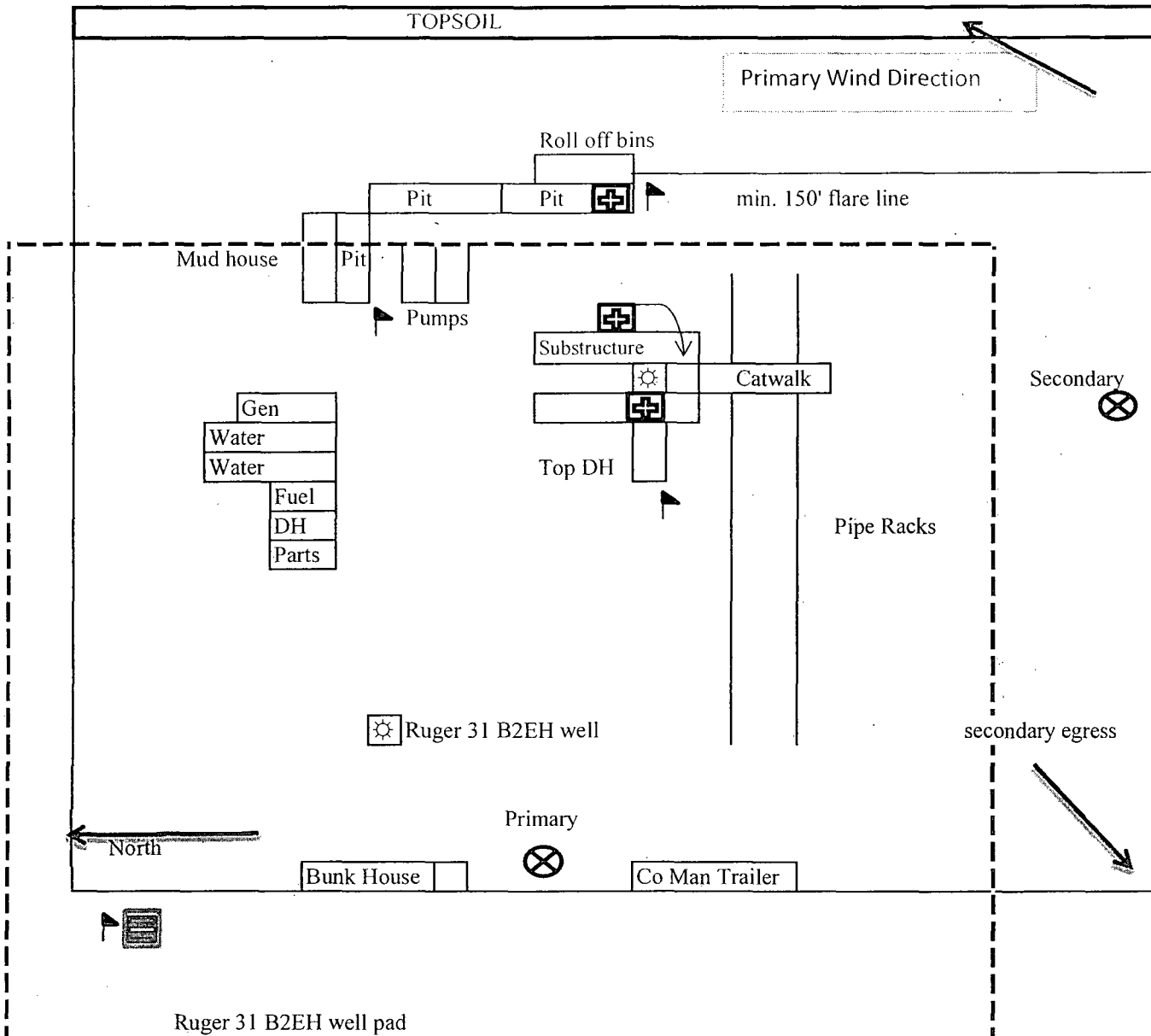

Eddy County, New Mexico

- I. Drilling nipple (bell nipple) to be constructed so that it can be removed without the use of a welder through the opening of the rotary table, with minimum internal diameter equal to blowout preventer bore.
- II. Blowout preventer and all fittings must be in good condition with a minimum 3000 psi working pressure on 9 5/8" and 7" casing.
- III. Safety valve must be available on the rig floor at all times with proper connections to install in the drill string. Valve must be full bore with minimum 3000 psi working pressure.
- IV. Equipment through which bit must pass shall be at least as large as internal diameter of the casing.
- V. A kelly cock shall be installed on the kelly at all times.

Blowout preventer closing equipment to include and accumulator of at least 40 gallon capacity, two independent sources of pressure on closing unit, and meet all other API specifications.



Mewbourne Oil Company
 Ruger 31 B3EH Fed #2H
 2345' FNL & 185' FWL
 Sec. 31, T19S, R29E
 Eddy County, NM

-  = Warning Signs
-  = Wind Markers
-  = H2S Monitors
-  = Safety Stations

Hydrogen Sulfide Drilling Operations Plan

Mewbourne Oil Company

Ruger 31 B3EH Fed #2H

2345' FNL & 185' FWL

Sec. 31-T19S-R29E

Eddy County, New Mexico

1. General Requirements

Rule 118 does not apply to this well because MOC has researched this area and no high concentrations of H₂S were found. MOC will have on location and working all H₂S safety equipment before the Delaware formation for purposes of safety and insurance requirements.

2. Hydrogen Sulfide Training

All personnel, whether regularly assigned, contracted, or employed on an unscheduled basis, will have received training from a qualified instructor in the following areas prior to entering the drilling pad area of the well:

1. The hazards and characteristics of hydrogen sulfide gas.
2. The proper use of personal protective equipment and life support systems.
3. The proper use of hydrogen sulfide detectors, alarms, warning systems, briefing areas, evacuation procedures.
4. The proper techniques for first aid and rescue operations.

Additionally, supervisory personnel will be trained in the following areas:

- 1 The effects of hydrogen sulfide on metal components. If high tensile tubular systems are utilized, supervisory personnel will be trained in their special maintenance requirements.
- 2 Corrective action and shut in procedures, blowout prevention, and well control procedures while drilling a well.
- 3 The contents of the Hydrogen Sulfide Drilling Operations Plan.

There will be an initial training session prior to encountering a known hydrogen sulfide source. The initial training session shall include a review of the site specific Hydrogen Sulfide Drilling Operations Plan.

3. Hydrogen Sulfide Safety Equipment and Systems

All hydrogen sulfide safety equipment and systems will be installed, tested, and operational prior to drilling below the 9 5/8" intermediate casing.

1. Well Control Equipment
 - A. Choke manifold with minimum of one adjustable choke/remote choke.
 - B. Blowout preventers equipped with blind rams and pipe rams to accommodate all pipe sizes with properly sized closing unit
 - C. Auxiliary equipment including annular type blowout preventer.
2. Protective Equipment for Essential Personnel

Thirty minute self contained work unit located in the dog house and at briefing areas.

Additionally: If H₂S is encountered in concentrations less than 10 ppm, fans will be placed in work areas to prevent the accumulation of hazardous amounts of poisonous gas. If higher concentrations of H₂S are detected the well will be shut in MOC will follow Onshore Order 6 and install a rotating head, mud/gas separator, remote choke and flare line with igniter will be installed.

3. Hydrogen Sulfide Protection and Monitoring Equipment

Two portable hydrogen sulfide monitors positioned on location for optimum coverage and detection. The units shall have audible sirens to notify personnel when hydrogen sulfide levels exceed 20 PPM.

4. Visual Warning Systems

A. Wind direction indicators as indicated on the wellsite diagram.

B. Caution signs shall be posted on roads providing access to location. Signs shall be painted a high visibility color with lettering of sufficient size to be readable at reasonable distances from potentially contaminated areas.

4. **Mud Program**

The mud program has been designed to minimize the amount of hydrogen sulfide entrained in the mud system. Proper mud weight, safe drilling practices, and the use of hydrogen sulfide scavengers will minimize hazards while drilling the well.

5. **Metallurgy**

All tubular systems, wellheads, blowout preventers, drilling spools, kill lines, choke manifolds, and valves shall be suitable for service in a hydrogen sulfide environment when chemically treated.

6. **Communications**

State & County Officials phone numbers are posted on rig floor and supervisors trailer. Communications in company vehicles and toolpushers are either two way radios or cellular phones.

7. **Well Testing**

Drill stem testing is not an anticipated requirement for evaluation of this well. A drill stem test is required, it will be conducted with a minimum number of personnel in the immediate vicinity. The test will be conducted during daylight hours only.

8. **Emergency Phone Numbers**

Lea County Sheriff's Office	911 or 575-396-3611
Ambulance Service	911 or 575-885-2111
Carlsbad Fire Dept	911 or 575-885-2111
Closest Medical Facility - Columbia Medical Center of Carlsbad	575-492-5000

Mewbourne Oil Company	Hobbs District Office	575-393-5905
	Fax	575-397-6252
	2 nd Fax	575-393-7259

District Manager	Micky Young	575-390-0999
Drilling Superintendent	Frosty Lathan	575-390-4103
	Bradley Bishop	575-390-6838
Drilling Foreman	Wesley Noseff	575-441-0729

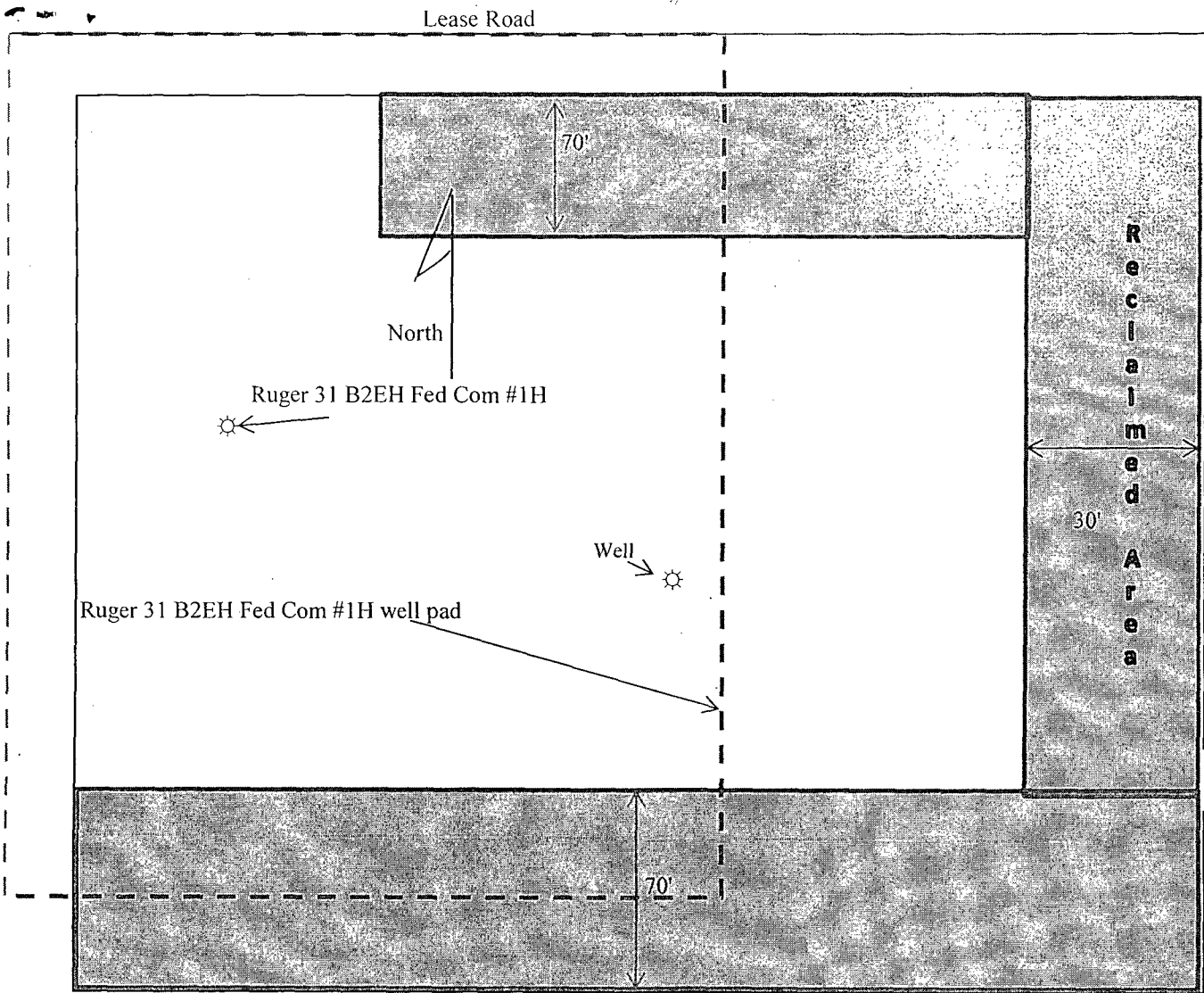

Exhibit "6"

Mewbourne Oil Company
 Ruger 31 B3EH Fed #2H
 2345' FNL & 185' FWL
 Sec. 31-T191S-R29E
 Eddy Co. NM

SURFACE USE PLAN OF OPERATIONS
MEWBOURNE OIL COMPANY

Ruger 31 B3EH Federal #2H
2345' FNL & 185 FWL (SHL)
Sec. 31 – T19S-R29E
Eddy County, New Mexico

Introduction

This plan is submitted with Form 3160-3, Application for Permit to Drill, Covering the above described well. The purpose of this plan is to describe the location of the proposed well, the proposed construction activities and operations plan, the magnitude of the surface disturbance involved, and the procedures to be followed in restoring the surface so that a complete appraisal can be made of the environmental impact associated with the proposed operations.

1. Existing Roads

- a. The existing access road route to the proposed project is depicted on Exhibit 3E. Improvements to the driving surface will be done where necessary. No new surface disturbance will be done, unless otherwise noted in the New or Reconstructed Access Roads section of this surface use plan.
- b. The existing oil and gas roads utilized to access the proposed project will be maintained by crowning, clearing ditches, and fixing potholes. All existing structures on the entire access route such as cattleguards, other range improvement projects, culverts, etc. will be properly repaired or replaced if they are damaged or have deteriorated beyond practical use.
- c. Mewbourne Oil Co. will cooperate with other operators in the maintenance of lease roads.

2. New or Reconstructed Access Roads

- a. No new road construction will be needed since the well pad adjoins a sufficient oil and gas road.

3. Location of Existing Wells

- a. Exhibit 4, 4A of the APD depicts all known wells within a one mile radius of the proposed well.

4. Location of Existing and/or Proposed Production Facilities

- a. All permanent, lasting more than 6 months, above ground structures including but not limited to pumpjacks, storage tanks, pipeline risers, meter housing, etc. that are not subject to safety requirements will be painted a non-reflective paint color that blends in with the surrounding landscape. The paint color will be one of the colors from the BLM Standard Environmental Colors chart selected by the BLM authorized officer.

- b. All proposed production facilities that are located on the well pad will be strategically placed to allow for maximum interim reclamation, recontouring, and revegetation of the well location.
- c. Production from the proposed well will be transported to the production facility located on the **Ruger 31 Fed #1H** well location. The location of the well is as follows: 660' FSL & 660' FWL, Sec 31-T19S-R29E, Eddy Co., NM.
- d. A pipeline to transport production will be installed from the proposed well to the existing production facility.
 - i. Mewbourne Oil Co. plans to install about **2935'** of surface pipeline.
 - ii. Mewbourne Oil Co. plans to install a 2 7/8" **surface steel** pipeline from the proposed well to the production facility. The working pressure of the pipeline will be about **125 psi**. If the pipeline route follows an existing road, the surface pipeline will be installed no farther than 15 feet from the edge of the road. All construction and maintenance activity will use the existing road where available.
 - iii. **Exhibit 3** depicts the proposed production pipeline route from the well to the production facility.
- e. If any plans change regarding the production facility or other infrastructure (pipeline, electric line, etc.), we will submit a sundry notice or right of way (if applicable) prior to installation of construction.
- f. An electric line will be applied for through a sundry notice or BLM right of way at a later date.

5. Location and Types of Water

- a. The well will be drilled with a combination of fresh water and brine water based mud systems. The water will be obtained from commercial suppliers in the area and/or hauled to the location by transport trucks over existing and proposed roads as identified above in this surface use plan.

6. Construction Materials

- a. Construction material that will be used to build the well pad and road will be caliche.
- b. The construction contractor will be solely responsible for securing construction materials required for this operation and paying any royalties that may be required on those materials.
- c. Obtaining caliche: One way of obtaining caliche to build locations and roads will be by "turning over" the location. This means, caliche will be obtained from the actual well site. A caliche permit will be obtained from BLM prior to obtaining caliche. Amount of caliche will vary for each pad. The procedure below has been approved by BLM personnel:

- i. The top 6 inches of topsoil is pushed off and stockpiled along the side of the location.
- ii. An approximate 160' X 160' area is used within the proposed well site to remove caliche.
- iii. Subsoil is removed and stockpiled within the surveyed well pad.
- iv. When caliche is found, material will be stock piled within the pad site to build the location and road.
- v. Then subsoil is pushed back in the hole and caliche is spread accordingly across entire location and road.
- vi. Once well is drilled, the stock piled top soil will be used for interim reclamation and spread along areas where caliche is picked up and the location size is reduced.
- vii. Neither caliche, nor subsoil will be stock piled outside of the well pad. Topsoil will be stockpiled along the edge of the pad as depicted in the Well Site Layout or survey plat.

In the event that no caliche is found onsite, caliche will be hauled in from a BLM, state, or private mineral pit. A BLM mineral material permit will be acquired prior to obtaining any mineral material from BLM pits or land.

7. Methods of Handling Waste

- a. The well will be drilled utilizing a closed loop system. Drill cuttings will be properly contained in steel tanks and taken to an NMOCD approved disposal facility.
- b. Drilling fluids and produced oil and water from the well during completion operations will be stored safely in closed containers and disposed of properly in an NMOCD approved disposal facility.
- c. Garbage and trash produced during drilling and completion operations will be collected in trash containers and disposed of properly at a state approved site. All trash on and around the well site will be collected for disposal.
- d. All human waste and grey water from drilling and completion operations will be properly contained and disposed of properly at a disposal facility.
- e. After drilling and completion operations, trash, chemicals, salts, frac sand and other waste material will be removed and disposed of properly at a disposal site.

8. Ancillary Facilities

- a. No ancillary facilities will be needed for this proposed project.

9. Well Site Layout

- a. The proposed drilling pad to be built was staked and surveyed by a professional surveyor. The attached survey plat of the well site depicts the drilling pad layout as staked.
- b. A title of a well site diagram is **Exhibit 5**. This diagram depicts the rig layout.
- c. In areas to be heavily disturbed, the top 6 inches of soil material, will be stripped and stockpiled on the perimeter of the well location to keep topsoil viable, and to make redistribution of topsoil more efficient during interim reclamation. Stockpiled topsoil should include vegetative material. Topsoil will be clearly segregated and stored separately from subsoils. Contaminated soil will not be stockpiled, but properly treated and handled prior to topsoil salvaging.

10. Plans for Surface Reclamation

Within 90 days of cessation of drilling and completion operations, all equipment not necessary for production operations will be removed. The location will be cleaned of all trash and junk to assure the well site is left as aesthetically pleasing as reasonably possible.

a. Interim Reclamation (well pad)

- i. Interim reclamation will be performed on the well site after the well is drilled and completed. **Exhibit 6** depicts the location and dimensions of the planned interim reclamation for the well site.
- ii. The well location and surrounding areas will be cleared of, and maintained free of, all materials, trash, and equipment not required for production.
- iii. In areas planned for interim reclamation, all the surfacing material will be removed and returned to the original mineral pit or recycled to repair or build roads and well pads.
- iv. The areas planned for interim reclamation will then be recontoured to the original contour if feasible, or if not feasible, to an interim contour that blends with the surrounding topography as much as possible. Where applicable, the fill material of the well pad will be backfilled into the cut to bring the area back to the original contour. The interim cut and fill slopes prior to re-seeding will not be steeper than a 3:1 ratio, unless the adjacent native topography is steeper. Note: Constructed slopes may be much steeper during drilling, but will be recontoured to the above ratios during interim reclamation.
- v. Topsoil will be evenly respread and aggressively revegetated over the entire disturbed area not needed for all-weather operations including cuts

& fills. To seed the area, the proper BLM seed mixture, free of noxious weeds, will be used. Final seedbed preparation will consist of contour cultivating to a depth of 4 to 6 inches within 24 hours prior to seeding, dozer tracking, or other imprinting in order to break the soil crust and create seed germination micro-sites.

- vi. Proper erosion control methods will be used on the area to control erosion, runoff and siltation of the surrounding area.
- vii. The interim reclamation will be monitored periodically to ensure that vegetation has reestablished and that erosion and invasive/noxious weeds are controlled.

b. Final Reclamation (well pad, buried pipelines, etc.)

- i. Prior to final reclamation procedures, the well pad, road, and surrounding area will be cleared of material, trash, and equipment.
- ii. All surfacing material will be removed and returned to the original mineral pit or recycled to repair or build roads and well pads.
- iii. All disturbed areas, including roads, pipelines, pads, production facilities, and interim reclaimed areas will be recontoured to the contour existing prior to initial construction or a contour that blends indistinguishably with the surrounding landscape. Topsoil that was spread over the interim reclamation areas will be stockpiled prior to recontouring. The topsoil will be redistributed evenly over the entire disturbed site to ensure successful revegetation.
- iv. After all the disturbed areas have been properly prepared, the areas will be seeded with the proper BLM seed mixture, free of noxious weeds. Final seedbed preparation will consist of contour cultivating to a depth of 4 to 6 inches within 24 hours prior to seeding, dozer tracking, or other imprinting in order to break the soil crust and create seed germination micro-sites.
- v. Proper erosion control methods will be used on the entire area to control erosion, runoff and siltation of the surrounding area.
- vi. All unused equipment and structures including pipelines, electric line poles, tanks, etc. that serviced the well will be removed.
- vii. All reclaimed areas will be monitored periodically to ensure that revegetation occurs, that the area is not redisturbed, and that erosion and invasive/noxious weeds are controlled.

11. Surface Ownership

- a. The surface ownership of the proposed project is private and federal. The access road is on private land and the well site is on federal land. The private land is owned by:

Surface Owner: Winston Ballard

Phone Number: 575-513-9366

Address: 104 Ole Barn Road, Carlsbad, NM 88220

- b. A surface use agreement was obtained from the private surface owner regarding the proposed project (access road).

12. Other Information

- a. No other information is needed at this time.

13. Operator's Representative

- a. Through APD approval, drilling, completion and production operations:

Robin Terrell, District Manager

Mewbourne Oil Company

PO Box 5270

Hobbs, NM 88241

575-393-5905

PECOS DISTRICT CONDITIONS OF APPROVAL

OPERATOR'S NAME:	Mewbourne Oil Co
LEASE NO.:	NM13237
WELL NAME & NO.:	2H-Ruger 31 B3EH Federal
SURFACE HOLE FOOTAGE:	2345'/N & 185'/W
BOTTOM HOLE FOOTAGE:	1850'/N & 330'/E
LOCATION:	Sec. 31, T. 19 S., R. 29 E.
COUNTY:	Eddy County, New Mexico

TABLE OF CONTENTS

Standard Conditions of Approval (COA) apply to this APD. If any deviations to these standards exist or special COAs are required, the section with the deviation or requirement will be checked below.

- General Provisions**
- Permit Expiration**
- Archaeology, Paleontology, and Historical Sites**
- Noxious Weeds**
- Special Requirements**
 - Pipeline Installation Requirements
 - Berm Pad
 - Cave/Karst
- Construction**
 - Notification
 - Topsoil
 - Closed Loop System
 - Federal Mineral Material Pits
 - Well Pads
 - Roads
- Road Section Diagram**
- Drilling**
 - High cave/karst
 - Capitan Reef
 - H2S requirements
 - Cement requirements
 - Logging requirements
 - Waste Material and Fluids
- Production (Post Drilling)**
 - Well Structures & Facilities
 - Pipelines
- Interim Reclamation**
- Final Abandonment & Reclamation**

I. GENERAL PROVISIONS

The approval of the Application For Permit To Drill (APD) is in compliance with all applicable laws and regulations: 43 Code of Federal Regulations 3160, the lease terms, Onshore Oil and Gas Orders, Notices To Lessees, New Mexico Oil Conservation Division (NMOCD) Rules, National Historical Preservation Act As Amended, and instructions and orders of the Authorized Officer. Any request for a variance shall be submitted to the Authorized Officer on Form 3160-5, Sundry Notices and Report on Wells.

II. PERMIT EXPIRATION

If the permit terminates prior to drilling and drilling cannot be commenced within 60 days after expiration, an operator is required to submit Form 3160-5, Sundry Notices and Reports on Wells, requesting surface reclamation requirements for any surface disturbance. However, if the operator will be able to initiate drilling within 60 days after the expiration of the permit, the operator must have set the conductor pipe in order to allow for an extension of 60 days beyond the expiration date of the APD. (Filing of a Sundry Notice is required for this 60 day extension.)

III. ARCHAEOLOGICAL, PALEONTOLOGY & HISTORICAL SITES

Any cultural and/or paleontological resource discovered by the operator or by any person working on the operator's behalf shall immediately report such findings to the Authorized Officer. The operator is fully accountable for the actions of their contractors and subcontractors. The operator shall suspend all operations in the immediate area of such discovery until written authorization to proceed is issued by the Authorized Officer. An evaluation of the discovery shall be made by the Authorized Officer to determine the appropriate actions that shall be required to prevent the loss of significant cultural or scientific values of the discovery. The operator shall be held responsible for the cost of the proper mitigation measures that the Authorized Officer assesses after consultation with the operator on the evaluation and decisions of the discovery. Any unauthorized collection or disturbance of cultural or paleontological resources may result in a shutdown order by the Authorized Officer.

IV. NOXIOUS WEEDS

The operator shall be held responsible if noxious weeds become established within the areas of operations. Weed control shall be required on the disturbed land where noxious weeds exist, which includes the roads, pads, associated pipeline corridor, and adjacent land affected by the establishment of weeds due to this action. The operator shall consult with the Authorized Officer for acceptable weed control methods, which include following EPA and BLM requirements and policies.

V. SPECIAL REQUIREMENT(S)

Pipeline Installation Requirements

1. The proposed production pipeline and future pipelines must follow the route depicted in the "Proposed Pipeline Map" in this COA document. It is similar to the pipeline map in the APD, but in more detail.
2. The pipeline must be installed on the east side of the proposed access road for the Ruger 31 DA Federal #1H.
3. When the pipeline travels across open country (north of Ruger 31 LI Fed #1H):
 - a. The pipeline route cannot be used as a road way. Mewbourne Oil Company must take necessary measures to prevent all vehicle traffic from traveling along this pipeline route. At a minimum, Mewbourne must have barricades at both ends of the pipeline route where the pipeline leaves an existing disturbance it is following (north side of Ruger 31 Fed #1H well pad and south side of Ruger 31 EH Fed #1H or existing lease road if this pad is not built). These barricades (example: fence) should be constructed in a way to prevent traffic on the pipeline route. If a road way develops on this pipeline route, Mewbourne will be responsible for reclaiming the trespass road to BLM reclamation standards.
 - b. Two pipelines must be installed at the same time between the Ruger 31 LI Fed #1H and proposed Ruger 31 EH Fed #1H to limit disturbance on the route. This is the only segment of the pipeline route that requires installation of two pipelines at the same time. Both pipelines must be installed immediately adjacent to each other (no farther than one foot) and travel in a straight line. The pipelines cannot have any horizontal curves or bends. Both pipelines must be secured to the ground with rebar or similar apparatus every 100 feet.
4. No fence shall be cut or disturbed in the installation of the pipeline.

Berming of the Well Pad

The entire perimeter of the well pad will be bermed to prevent oil, salt, and other chemical contaminants from leaving the well pad.

- The berm shall be constructed at a minimum of 24 inches high with impermeable mineral material (e.g. caliche).
- No water flow from the uphill side(s) of the pad shall be allowed to enter the well pad.
- The topsoil stockpile shall be located outside the bermed well pad.
- Topsoil, either from the well pad or surrounding area, shall not be used to construct the berm.
- No storm drains, tubing or openings shall be placed in the berm.
- If fluid collects within the bermed area, the fluid must be vacuumed into a safe container and disposed of properly at a state approved facility.
- The integrity of the berm shall be maintained around the surfaced pad throughout the life of the well and around the downsized pad after interim reclamation has been completed.

Any access road entering the well pad shall be constructed so that the integrity of the berm height surrounding the well pad is not compromised. (Any access road crossing the berm cannot be lower than the berm height.)

Cave and Karst

** Depending on location, additional Drilling, Casing, and Cementing procedures may be required by engineering to protect critical karst groundwater recharge areas.

Cave/Karst Surface Mitigation

The following stipulations will be applied to minimize impacts during construction, drilling and production.

Construction:

In the advent that any underground voids are opened up during construction activities, construction activities will be halted and the BLM will be notified immediately.

No Blasting:

No blasting will be utilized for pad construction. The pad will be constructed and leveled by adding the necessary fill and caliche.

Pad Berming:

The entire perimeter of the well pad will be bermed to prevent oil, salt, and other chemical contaminants from leaving the well pad.

- The compacted berm shall be constructed at a minimum of 12 inches high with impermeable mineral material (e.g. caliche).
- No water flow from the uphill side(s) of the pad shall be allowed to enter the well pad.
- The topsoil stockpile shall be located outside the bermed well pad.
- Topsoil, either from the well pad or surrounding area, shall not be used to construct the berm.
- No storm drains, tubing or openings shall be placed in the berm.
- If fluid collects within the bermed area, the fluid must be vacuumed into a safe container and disposed of properly at a state approved facility.
- The integrity of the berm shall be maintained around the surfaced pad throughout the life of the well and around the downsized pad after interim reclamation has been completed.
- Any access road entering the well pad shall be constructed so that the integrity of the berm height surrounding the well pad is not compromised. (Any access road crossing the berm cannot be lower than the berm height.)

Tank Battery Liners and Berms:

Tank battery locations will be lined and bermed. A 20 mil permanent liner will be installed with a 4 oz. felt backing to prevent tears or punctures. Tank battery berms must be large enough to contain 1 ½ times the content of the largest tank.

Leak Detection System:

A method of detecting leaks is required. The method could incorporate gauges to measure loss, siting valves and lines so they can be visually inspected, or installing electronic sensors to alarm when a leak is present. Leak detection plan will be submitted to BLM for approval.

Automatic Shut-off Systems:

Automatic shut off, check valves, or similar systems will be installed for pipelines and tanks to minimize the effects of catastrophic line failures used in production or drilling.

Cave/Karst Subsurface Mitigation

The following stipulations will be applied to protect cave/karst and ground water concerns:

Rotary Drilling with Fresh Water:

Fresh water will be used as a circulating medium in zones where caves or karst features are expected. SEE ALSO: Drilling COAs for this well.

Directional Drilling:

Kick off for directional drilling will occur at least 100 feet below the bottom of the cave occurrence zone. SEE ALSO: Drilling COAs for this well.

Lost Circulation:

ALL lost circulation zones from the surface to the base of the cave occurrence zone will be logged and reported in the drilling report.

Regardless of the type of drilling machinery used, if a void of four feet or more and circulation losses greater than 70 percent occur simultaneously while drilling in any cave-bearing zone, the BLM will be notified immediately by the operator. The BLM will assess the situation and work with the operator on corrective actions to resolve the problem.

Abandonment Cementing:

Upon well abandonment in high cave karst areas additional plugging conditions of approval may be required. The BLM will assess the situation and work with the operator to ensure proper plugging of the wellbore.

Pressure Testing:

Annual pressure monitoring will be performed by the operator on all casing annuli and reported in a sundry notice. If the test results indicated a casing failure has occurred, remedial action will be undertaken to correct the problem to the BLM's approval.

Proposed Pipeline Map

Ruger 31 DA Fed #1H

Ruger 31 EH Fed #1H

Ruger 31 LI Fed #1H

Ruger 31 MP Fed #1H

Ruger 31
Tank Battery

T 019 S
R 028 E

030

T 019 S
R 029 E
031



No warranty is made by the Bureau of Land Management as to the accuracy, reliability, or completeness of these data for individual use or aggregate use with other data, or for purposes not intended by BLM. Spatial information may not meet National Map Accuracy Standards. This information may be updated without notification.

Legend	
	Proposed Pipeline
	Access Road
	Well Pad
	NM Townships
	NM Sections

T 020 S 0
R 028 E

345 006 690

1:380

Feet

VI. CONSTRUCTION

A. NOTIFICATION

The BLM shall administer compliance and monitor construction of the access road and well pad. Notify the Carlsbad Field Office at (575) 234-5909 at least 3 working days prior to commencing construction of the access road and/or well pad.

When construction operations are being conducted on this well, the operator shall have the approved APD and Conditions of Approval (COA) on the well site and they shall be made available upon request by the Authorized Officer.

B. TOPSOIL

The operator shall strip the top portion of the soil (root zone) from the entire well pad area and stockpile the topsoil along the edge of the well pad as depicted in the APD. The root zone is typically six (6) inches in depth. All the stockpiled topsoil will be redistributed over the interim reclamation areas. Topsoil shall not be used for berming the pad or facilities. For final reclamation, the topsoil shall be spread over the entire pad area for seeding preparation.

Other subsoil (below six inches) stockpiles must be completely segregated from the topsoil stockpile. Large rocks or subsoil clods (not evident in the surrounding terrain) must be buried within the approved area for interim and final reclamation.

C. CLOSED LOOP SYSTEM

Tanks are required for drilling operations: No Pits.

The operator shall properly dispose of drilling contents at an authorized disposal site.

D. FEDERAL MINERAL MATERIALS PIT

Payment shall be made to the BLM prior to removal of any federal mineral materials. Call the Carlsbad Field Office at (575) 234-5972.

E. WELL PAD SURFACING

Surfacing of the well pad is not required.

If the operator elects to surface the well pad, the surfacing material may be required to be removed at the time of reclamation. The well pad shall be constructed in a manner which creates the smallest possible surface disturbance, consistent with safety and operational needs.

F. EXCLOSURE FENCING (CELLARS & PITS)

Exclosure Fencing

The operator will install and maintain exclosure fencing for all open well cellars to prevent access to public, livestock, and large forms of wildlife before and after drilling operations until the pit is free of fluids and the operator initiates backfilling. (For examples of exclosure fencing design, refer to BLM's Oil and Gas Gold Book, Exclosure Fence Illustrations, Figure 1, Page 18.)

G. ON LEASE ACCESS ROADS

Road Width

The access road shall have a driving surface that creates the smallest possible surface disturbance and does not exceed fourteen (14) feet in width. The maximum width of surface disturbance, when constructing the access road, shall not exceed twenty-five (25) feet.

Surfacing

Surfacing material is not required on the new access road driving surface. If the operator elects to surface the new access road or pad, the surfacing material may be required to be removed at the time of reclamation.

Where possible, no improvements should be made on the unsurfaced access road other than to remove vegetation as necessary, road irregularities, safety issues, or to fill low areas that may sustain standing water.

The Authorized Officer reserves the right to require surfacing of any portion of the access road at any time deemed necessary. Surfacing may be required in the event the road deteriorates, erodes, road traffic increases, or it is determined to be beneficial for future field development. The surfacing depth and type of material will be determined at the time of notification.

Crowning

Crowning shall be done on the access road driving surface. The road crown shall have a grade of approximately 2% (i.e., a 1" crown on a 14' wide road). The road shall conform to Figure 1; cross section and plans for typical road construction.

Ditching

Ditching shall be required on both sides of the road.

Turnouts

Vehicle turnouts shall be constructed on the road. Turnouts shall be intervisible with interval spacing distance less than 1000 feet. Turnouts shall conform to Figure 1; cross section and plans for typical road construction.

Drainage

Drainage control systems shall be constructed on the entire length of road (e.g. ditches, sidehill outsloping and insloping, lead-off ditches, culvert installation, and low water crossings).

A typical lead-off ditch has a minimum depth of 1 foot below and a berm of 6 inches above natural ground level. The berm shall be on the down-slope side of the lead-off ditch.

Cross Section of a Typical Lead-off Ditch

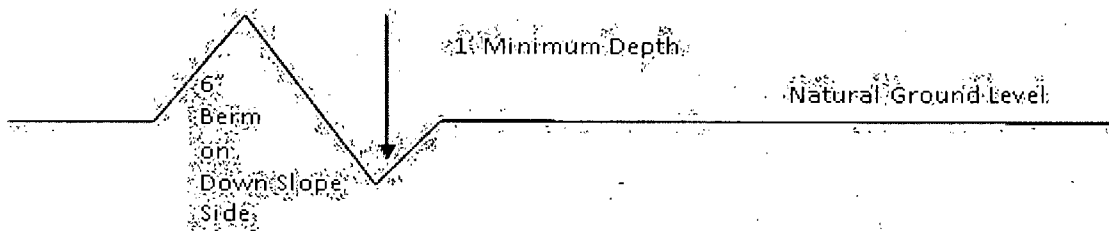

All lead-off ditches shall be graded to drain water with a 1 percent minimum to 3 percent maximum ditch slope. The spacing interval are variable for lead-off ditches and shall be determined according to the formula for spacing intervals of lead-off ditches, but may be amended depending upon existing soil types and centerline road slope (in %);

Formula for Spacing Interval of Lead-off Ditches

Example - On a 4% road slope that is 400 feet long, the water flow shall drain water into a lead-off ditch. Spacing interval shall be determined by the following formula:

$$400 \text{ foot road with } 4\% \text{ road slope: } \frac{400'}{4\%} + 100' = 200' \text{ lead-off ditch interval}$$

Cattleguards

An appropriately sized cattleguard sufficient to carry out the project shall be installed and maintained at fence/road crossings. Any existing cattleguards on the access road route shall be repaired or replaced if they are damaged or have deteriorated beyond practical use. The operator shall be responsible for the condition of the existing cattleguards that are in place and are utilized during lease operations.

Fence Requirement

Where entry is granted across a fence line, the fence shall be braced and tied off on both sides of the passageway prior to cutting. The operator shall notify the private surface landowner or the grazing allotment holder prior to crossing any fences.

Public Access

Public access on this road shall not be restricted by the operator without specific written approval granted by the Authorized Officer.

Construction Steps

1. Salvage topsoil
2. Construct road

3. Redistribute topsoil
4. Revegetate slopes

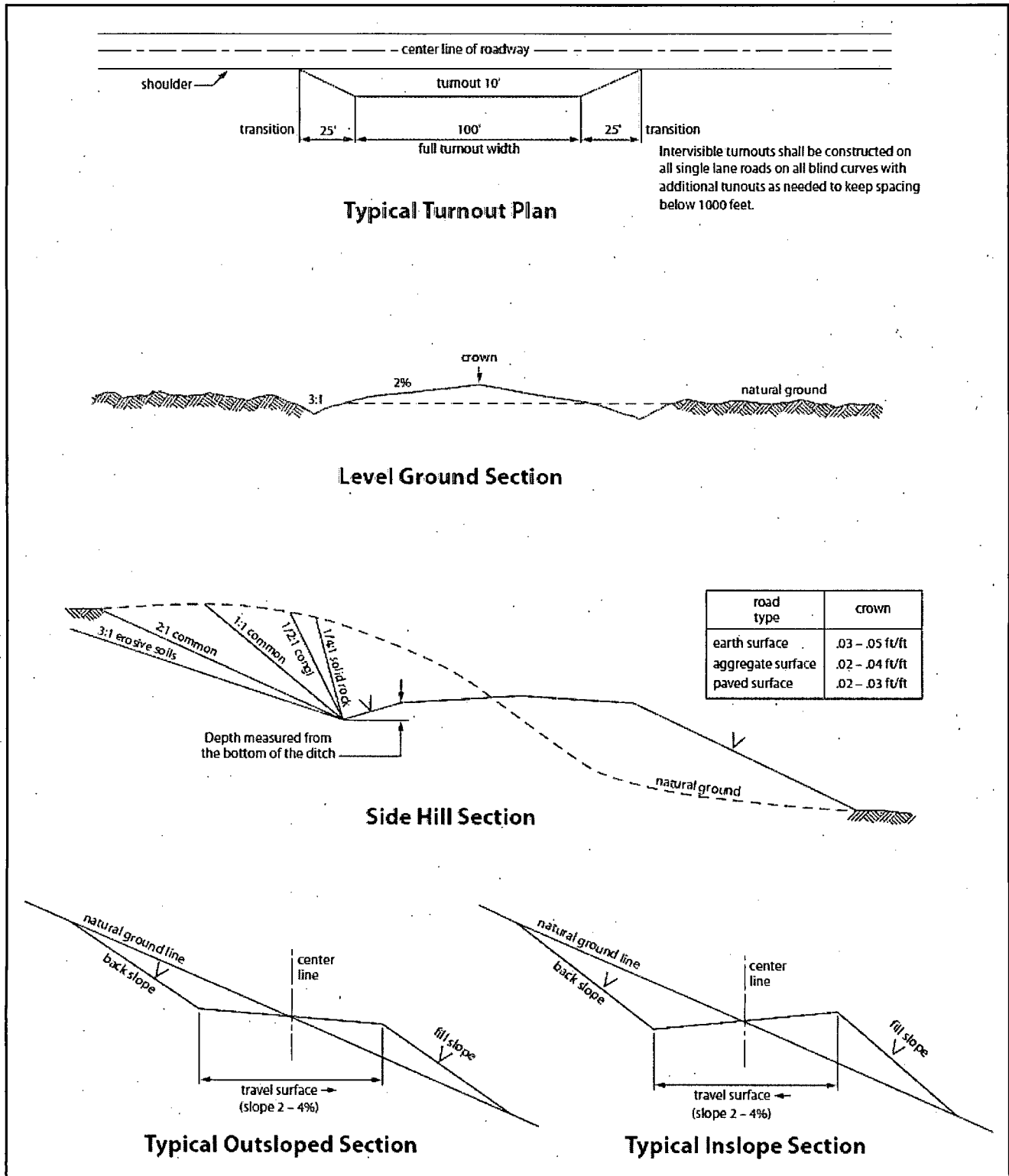

Figure 1. Cross-sections and plans for typical road sections representative of BLM resource or FS local and higher-class roads.

VII. DRILLING

A. DRILLING OPERATIONS REQUIREMENTS

The BLM is to be notified in advance for a representative to witness:

- a. Spudding well (minimum of 24 hours)
- b. Setting and/or Cementing of all casing strings (minimum of 4 hours)
- c. BOPE tests (minimum of 4 hours)

Eddy County

Call the Carlsbad Field Office, 620 East Greene St., Carlsbad, NM 88220,
(575) 361-2822

1. A Hydrogen Sulfide (H₂S) Drilling Plan shall be activated 500 feet prior to drilling into the **Bone Spring** formation. **As a result, the Hydrogen Sulfide area must meet Onshore Order 6 requirements, which includes equipment and personnel/public protection items. If Hydrogen Sulfide is encountered, please provide measured values and formations to the BLM.**
2. Unless the production casing has been run and cemented or the well has been properly plugged, the drilling rig shall not be removed from over the hole without prior approval. **If the drilling rig is removed without approval – an Incident of Non-Compliance will be written and will be a “Major” violation.**
3. Floor controls are required for 3M or Greater systems. These controls will be on the rig floor, unobstructed, readily accessible to the driller and will be operational at all times during drilling and/or completion activities. Rig floor is defined as the area immediately around the rotary table; the area immediately above the substructure on which the draw works is located, this does not include the dog house or stairway area.
4. **The record of the drilling rate along with the GR/N well log run from TD to surface (horizontal well – vertical portion of hole) shall be submitted to the BLM office as well as all other logs run on the borehole 30 days from completion. If available, a digital copy of the logs is to be submitted in addition to the paper copies. The Rustler top and top and bottom of Salt are to be recorded on the Completion Report.**

B. CASING

Changes to the approved APD casing program need prior approval if the items substituted are of lesser grade or different casing size or are Non-API. The Operator can exchange the components of the proposal with that of superior strength (i.e. changing from J-55 to N-80, or from 36# to 40#). Changes to the approved cement program need prior approval if the altered cement plan has less volume or strength or if the changes are substantial (i.e. Multistage tool, ECP, etc.).

Centralizers required on surface casing per Onshore Order 2.III.B.1.f.

Wait on cement (WOC) time prior to drilling out for a primary cement job will be a minimum 18 hours for a water basin, 24 hours in the potash area, or 500 pounds compressive strength, whichever is greater for all casing strings. **DURING THIS WOC TIME, NO DRILL PIPE, ETC. SHALL BE RUN IN THE HOLE.** Provide compressive strengths including hours to reach required 500 pounds compressive strength prior to cementing each casing string. **IF OPERATOR DOES NOT HAVE THE WELL SPECIFIC CEMENT DETAILS ONSITE PRIOR TO PUMPING THE CEMENT FOR EACH CASING STRING, THE WOC WILL BE 30 HOURS.** See individual casing strings for details regarding lead cement slurry requirements.

No pea gravel permitted for remedial or fall back remedial without prior authorization from the BLM engineer.

Capitan Reef

Possible water flows Artesia Group, Salado, and Queen.

Possible lost circulation in the Artesia Group, Rustler, Grayburg, Capitan Reef, and Delaware.

A MINIMUM OF TWO CASING STRINGS CEMENTED TO SURFACE IS REQUIRED IN HIGH CAVE/KARST AREAS. THE CEMENT MUST BE IN A SOLID SHEATH. THEREFORE, ONE INCH OPERATIONS ARE NOT SUFFICIENT TO PROTECT CAVE KARST RESOURCES. A CASING DESIGN THAT HAS A ONE INCH JOB PERFORMED DOES NOT COUNT AS A SOLID SHEATH.

1. The 20 inch surface casing shall be set at approximately 350 feet (a minimum of 25 feet into the Rustler Anhydrite and above the salt) and cemented to the surface. **If salt is encountered, set casing at least 25 feet above the salt. Fresh water mud to setting depth. Excess cement calculates to 16% - Additional cement may be required.**

- a. If cement does not circulate to the surface, the appropriate BLM office shall be notified and a temperature survey utilizing an electronic type temperature survey with surface log readout will be used or a cement bond log shall be run to verify the top of the cement. Temperature survey will be run a minimum of six hours after pumping cement and ideally between 8-10 hours after completing the cement job.
- b. **Wait on cement (WOC) time for a primary cement job is to include the lead cement slurry.**
- c. Wait on cement (WOC) time for a remedial job will be a minimum of 4 hours after bringing cement to surface or 500 pounds compressive strength, whichever is greater.
- d. If cement falls back, remedial cementing will be done prior to drilling out that string.

13-3/8 inch 1st Intermediate casing shall be kept fluid filled while running into hole to meet BLM minimum collapse requirements as operator design is slightly less.

2. The minimum required fill of cement behind the 13-3/8 inch 1st intermediate casing is:

- Cement to surface. If cement does not circulate see B.1.a, c-d above. **Excess calculates to 20% - Additional cement may be required. Wait on cement (WOC) time for a primary cement job is to include the lead cement slurry due to cave/karst.**

3. The minimum required fill of cement behind the 9-5/8 inch 2nd intermediate casing is:

Operator has proposed DV tool at depth of 1400'. Operator is to submit sundry if DV tool depth varies by more than 100' from approved depth.

- a. First stage to DV tool:

- Cement to circulate. If cement does not circulate, contact the appropriate BLM office before proceeding with second stage cement job. Operator should have plans as to how they will achieve circulation on the next stage.

- b. Second stage above DV tool:

- Cement to surface. If cement does not circulate see B.1.a, c-d above. **Wait on cement (WOC) time for a primary cement job is to include the lead cement slurry due to cave/karst and Captian Reef. Excess calculates to 3% - Additional cement may be required.**

Centralizers required through the curve and a minimum of one every other joint.

4. The minimum required fill of cement behind the 7 inch production casing is:
 - Cement top shall be a minimum of 50' above the top of the Capitan Reef – estimated at 2135', cement top 2085' or shallower. Operator shall provide method of verification.
5. Cement not required on the 4-1/2" casing. **Packer system being used.**
6. If hardband drill pipe is rotated inside casing, returns will be monitored for metal. If metal is found in samples, drill pipe will be pulled and rubber protectors which have a larger diameter than the tool joints of the drill pipe will be installed prior to continuing drilling operations.

C. PRESSURE CONTROL

1. All blowout preventer (BOP) and related equipment (BOPE) shall comply with well control requirements as described in Onshore Oil and Gas Order No. 2 and API RP 53 Sec. 17.
2. **A variance is granted for the use of a diverter on the 20" surface casing.**
3. Minimum working pressure of the blowout preventer (BOP) and related equipment (BOPE) required for drilling below the 13-3/8 1st intermediate casing shoe shall be **2000 (2M) psi.**
4. Minimum working pressure of the blowout preventer (BOP) and related equipment (BOPE) required for drilling below the 9-5/8 2nd intermediate casing shoe shall be **3000 (3M) psi.**
5. The appropriate BLM office shall be notified a minimum of 4 hours in advance for a representative to witness the tests.
 - a. In a water basin, for all casing strings utilizing slips, these are to be set as soon as the crew and rig are ready and any fallback cement remediation has been done. The casing cut-off and BOP installation can be initiated four hours after installing the slips, which will be approximately six hours after bumping the plug. For those casing strings not using slips, the minimum wait time before cut-off is eight hours after bumping the plug. BOP/BOPE testing can begin after cut-off or once cement reaches 500 psi compressive strength (including lead when specified); whichever is greater. However, if the float does not hold, cut-off cannot be initiated until cement reaches 500 psi compressive strength (including lead when specified).

- b. The tests shall be done by an independent service company utilizing a test plug **not a cup or J-packer**.
- c. The test shall be run on a 5000 psi chart for a 2-3M BOP/BOP, on a 10000 psi chart for a 5M BOP/BOPE and on a 15000 psi chart for a 10M BOP/BOPE. If a linear chart is used, it shall be a one hour chart. A circular chart shall have a maximum 2 hour clock. If a twelve hour or twenty-four hour chart is used, tester shall make a notation that it is run with a two hour clock.
- d. The results of the test shall be reported to the appropriate BLM office.
- e. All tests are required to be recorded on a calibrated test chart. **A copy of the BOP/BOPE test chart and a copy of independent service company test will be submitted to the appropriate BLM office.**
- f. The BOP/BOPE test shall include a low pressure test from 250 to 300 psi. The test will be held for a minimum of 10 minutes if test is done with a test plug and 30 minutes without a test plug. This test shall be performed prior to the test at full stack pressure.

D. DRILL STEM TEST

If drill stem tests are performed, Onshore Order 2.III.D shall be followed.

E. WASTE MATERIAL AND FLUIDS

All waste (i.e. drilling fluids, trash, salts, chemicals, sewage, gray water, etc.) created as a result of drilling operations and completion operations shall be safely contained and disposed of properly at a waste disposal facility. No waste material or fluid shall be disposed of on the well location or surrounding area.

Porto-johns and trash containers will be on-location during fracturing operations or any other crew-intensive operations.

WWI 081314

VIII. PRODUCTION (POST DRILLING)

A. WELL STRUCTURES & FACILITIES

Placement of Production Facilities

Production facilities should be placed on the well pad to allow for maximum interim recontouring and revegetation of the well location.

Exclosure Netting (Open-top Tanks)

Immediately following active drilling or completion operations, the operator will take actions necessary to prevent wildlife and livestock access, including avian wildlife, to all open-topped tanks that contain or have the potential to contain salinity sufficient to cause harm to wildlife or livestock, hydrocarbons, or Resource Conservation and Recovery Act of 1976-exempt hazardous substances. At a minimum, the operator will net, screen, or cover open-topped tanks to exclude wildlife and livestock and prevent mortality. If the operator uses netting, the operator will cover and secure the open portion of the tank to prevent wildlife entry. The operator will net, screen, or cover the tanks until the operator removes the tanks from the location or the tanks no longer contain substances that could be harmful to wildlife or livestock. Use a maximum netting mesh size of 1 ½ inches. The netting must not be in contact with fluids and must not have holes or gaps.

Chemical and Fuel Secondary Containment and Exclosure Screening

The operator will prevent all hazardous, poisonous, flammable, and toxic substances from coming into contact with soil and water. At a minimum, the operator will install and maintain an impervious secondary containment system for any tank or barrel containing hazardous, poisonous, flammable, or toxic substances sufficient to contain the contents of the tank or barrel and any drips, leaks, and anticipated precipitation. The operator will dispose of fluids within the containment system that do not meet applicable state or U. S. Environmental Protection Agency livestock water standards in accordance with state law; the operator must not drain the fluids to the soil or ground. The operator will design, construct, and maintain all secondary containment systems to prevent wildlife and livestock exposure to harmful substances. At a minimum, the operator will install effective wildlife and livestock exclosure systems such as fencing, netting, expanded metal mesh, lids, and grate covers. Use a maximum netting mesh size of 1 ½ inches.

Open-Vent Exhaust Stack Exclosures

The operator will construct, modify, equip, and maintain all open-vent exhaust stacks on production equipment to prevent birds and bats from entering, and to discourage perching, roosting, and nesting. (*Recommended exclosure structures on open-vent exhaust stacks are in the shape of a cone.*) Production equipment includes, but may not be limited to, tanks, heater-treaters, separators, dehydrators, flare stacks, in-line units, and compressor mufflers.

Containment Structures

Proposed production facilities such as storage tanks and other vessels will have a secondary containment structure that is constructed to hold the capacity of 1.5 times the largest tank, plus freeboard to account for precipitation, unless more stringent protective requirements are deemed necessary.

Painting Requirement

All above-ground structures including meter housing that are not subject to safety requirements shall be painted a flat non-reflective paint color, **Shale Green** from the BLM Standard Environmental Color Chart (CC-001: June 2008).

B. PIPELINES

1. The holder shall indemnify the United States against any liability for damage to life or property arising from the occupancy or use of public lands under this grant.
2. The holder shall comply with all applicable Federal laws and regulations existing or hereafter enacted or promulgated. In any event, the holder shall comply with the Toxic Substances Control Act of 1976 as amended, 15 USC 2601 et seq. (1982) with regards to any toxic substances that are used, generated by or stored on the right-of-way or on facilities authorized under this right-of-way grant. (See 40 CFR, Part 702-799 and especially, provisions on polychlorinated biphenyls, 40 CFR 761.1-761.193.) Additionally, any release of toxic substances (leaks, spills, etc.) in excess of the reportable quantity established by 40 CFR, Part 117 shall be reported as required by the Comprehensive Environmental Response, Compensation, and Liability Act, section 102b. A copy of any report required or requested by any Federal agency or State government as a result of a reportable release or spill of any toxic substances shall be furnished to the authorized officer concurrent with the filing of the reports to the involved Federal agency or State government.
3. The holder agrees to indemnify the United States against any liability arising from the release of any hazardous substance or hazardous waste (as these terms are defined in the Comprehensive Environmental Response, Compensation and Liability Act of 1980, 42 U.S.C. 9601, et seq. or the Resource Conservation and Recovery Act, 42 U.S.C. 6901, et seq.) on the Right-of-Way (unless the release or threatened release is wholly unrelated to activity of the Right-of-Way holder's activity on the Right-of-Way), or resulting from the activity of the Right-of-Way holder on the Right-of-Way. This agreement applies without regard to whether a release is caused by the holder, its agent, or unrelated third parties.
4. The holder shall be liable for damage or injury to the United States to the extent provided by 43 CFR Sec. 2883.1-4. The holder shall be held to a standard of strict liability for damage or injury to the United States resulting from pipe rupture, fire, or spills caused or substantially aggravated by any of the following within the right-of-way or permit area:

- a. Activities of the holder including, but not limited to construction, operation, maintenance, and termination of the facility.
- b. Activities of other parties including, but not limited to:
 - (1) Land clearing.
 - (2) Earth-disturbing and earth-moving work.
 - (3) Blasting.
 - (4) Vandalism and sabotage.
- c. Acts of God.

The maximum limitation for such strict liability damages shall not exceed one million dollars (\$1,000,000) for any one event, and any liability in excess of such amount shall be determined by the ordinary rules of negligence of the jurisdiction in which the damage or injury occurred.

This section shall not impose strict liability for damage or injury resulting primarily from an act of war or from the negligent acts or omissions of the United States.

5. If, during any phase of the construction, operation, maintenance, or termination of the pipeline, any oil, salt water, or other pollutant should be discharged from the pipeline system, impacting Federal lands, the control and total removal, disposal, and cleaning up of such oil, salt water, or other pollutant, wherever found, shall be the responsibility of the holder, regardless of fault. Upon failure of the holder to control, dispose of, or clean up such discharge on or affecting Federal lands, or to repair all damages resulting therefrom, on the Federal lands, the Authorized Officer may take such measures as he deems necessary to control and clean up the discharge and restore the area, including, where appropriate, the aquatic environment and fish and wildlife habitats, at the full expense of the holder. Such action by the Authorized Officer shall not relieve the holder of any responsibility as provided herein.

6. All construction and maintenance activity will be confined to the authorized right-of-way width of 20 feet. If the pipeline route follows an existing road or buried pipeline right-of-way, the surface pipeline must be installed no farther than 10 feet from the edge of the road or buried pipeline right-of-way. If existing surface pipelines prevent this distance, the proposed surface pipeline must be installed immediately adjacent to the outer surface pipeline. All construction and maintenance activity will be confined to existing roads or right-of-ways.

7. No blading or clearing of any vegetation will be allowed unless approved in writing by the Authorized Officer.

8. The holder shall install the pipeline on the surface in such a manner that will minimize suspension of the pipeline across low areas in the terrain. In hummocky or dune areas, the pipeline will be "snaked" around hummocks and dunes rather than suspended across these features.

9. The pipeline shall be buried with a minimum of 24 inches under all roads, "two-tracks," and trails. Burial of the pipe will continue for 20 feet on each side of each crossing. The condition of the road, upon completion of construction, shall be returned to at least its former state with no bumps or dips remaining in the road surface.

10. The holder shall minimize disturbance to existing fences and other improvements on public lands. The holder is required to promptly repair improvements to at least their former state. Functional use of these improvements will be maintained at all times. The holder will contact the owner of any improvements prior to disturbing them. When necessary to pass through a fence line, the fence shall be braced on both sides of the passageway prior to cutting of the fence. No permanent gates will be allowed unless approved by the Authorized Officer.

11. In those areas where erosion control structures are required to stabilize soil conditions, the holder will install such structures as are suitable for the specific soil conditions being encountered and which are in accordance with sound resource management practices.

12. Excluding the pipe, all above-ground structures not subject to safety requirement shall be painted by the holder to blend with the natural color of the landscape. The paint used shall be a color which simulates "Standard Environmental Colors" – **Shale Green**, Munsell Soil Color No. 5Y 4/2; designated by the Rocky Mountain Five State Interagency Committee.

13. The pipeline will be identified by signs at the point of origin and completion of the right-of-way and at all road crossings. At a minimum, signs will state the holder's name, BLM serial number, and the product being transported. Signs will be maintained in a legible condition for the life of the pipeline.

14. The holder shall not use the pipeline route as a road for purposes other than routine maintenance as determined necessary by the Authorized Officer in consultation with the holder. The holder will take whatever steps are necessary to ensure that the pipeline route is not used as a roadway.

15. Any cultural and/or paleontological resource (historic or prehistoric site or object) discovered by the holder, or any person working on his behalf, on public or Federal land shall be immediately reported to the authorized officer. Holder shall suspend all operations in the immediate area of such discovery until written authorization to proceed is issued by the authorized officer. An evaluation of the discovery will be made by the authorized officer to determine appropriate cultural or scientific values. The holder will be responsible for the cost of evaluation and any decision as to proper mitigation measures will be made by the authorized officer after consulting with the holder.

16. The operator shall be held responsible if noxious weeds become established within the areas of operations. Weed control shall be required on the disturbed land where noxious weeds exist, which includes the roads, powerline corridor, and adjacent land affected by the establishment of weeds due to this action. The operator shall consult with the Authorized Officer for acceptable weed control methods, which include following EPA and BLM requirements and policies.

17. Surface pipelines must be less than or equal to 4 inches and a working pressure below 125 psi.

IX. INTERIM RECLAMATION

During the life of the development, all disturbed areas not needed for active support of production operations should undergo interim reclamation in order to minimize the environmental impacts of development on other resources and uses.

Within six (6) months of well completion, operators should work with BLM surface management specialists (Jim Amos: 575-234-5909) to devise the best strategies to reduce the size of the location. Interim reclamation should allow for remedial well operations, as well as safe and efficient removal of oil and gas.

During reclamation, the removal of caliche is important to increasing the success of revegetating the site. Removed caliche that is free of contaminants may be used for road repairs, fire walls or for building other roads and locations. In order to operate the well or complete workover operations, it may be necessary to drive, park and operate on restored interim vegetation within the previously disturbed area. Disturbing revegetated areas for production or workover operations will be allowed. If there is significant disturbance and loss of vegetation, the area will need to be revegetated. Communicate with the appropriate BLM office for any exceptions/exemptions if needed.

All disturbed areas after they have been satisfactorily prepared need to be reseeded with the seed mixture provided below.

Upon completion of interim reclamation, the operator shall submit a Sundry Notices and Reports on Wells, Subsequent Report of Reclamation (Form 3160-5).

X. FINAL ABANDONMENT & RECLAMATION

At final abandonment, well locations, production facilities, and access roads must undergo "final" reclamation so that the character and productivity of the land are restored.

Earthwork for final reclamation must be completed within six (6) months of well plugging. All pads, pits, facility locations and roads must be reclaimed to a satisfactory revegetated, safe, and stable condition, unless an agreement is made with the landowner or BLM to keep the road and/or pad intact.

After all disturbed areas have been satisfactorily prepared, these areas need to be revegetated with the seed mixture provided below. Seeding should be accomplished by drilling on the contour whenever practical or by other approved methods. Seeding may need to be repeated until revegetation is successful, as determined by the BLM.

Operators shall contact a BLM surface protection specialist prior to surface abandonment operations for site specific objectives (Jim Amos: 575-234-5909).

Seed Mixture 1, for Loamy Sites

The holder shall seed all disturbed areas with the seed mixture listed below. The seed mixture shall be planted in the amounts specified in pounds of pure live seed (PLS)* per acre. There shall be no primary or secondary noxious weeds in the seed mixture. Seed will be tested and the viability testing of seed will be done in accordance with State law(s) and within nine (9) months prior to purchase. Commercial seed will be either certified or registered seed. The seed container will be tagged in accordance with State law(s) and available for inspection by the authorized officer.

Seed will be planted using a drill equipped with a depth regulator to ensure proper depth regulator to ensure proper depth of planting where drilling is possible. The seed mixture will be evenly and uniformly planted over the disturbed area (small/heavier seeds have a tendency to drop the bottom of the drill and are planted first). The holder shall take appropriate measures to ensure this does not occur. Where drilling is not possible, seed will be broadcast and the area shall be raked or chained to cover the seed. When broadcasting the seed, the pounds per acre are to be doubled. The seeding will be repeated until a satisfactory stand is established as determined by the authorized officer. Evaluation of growth will not be made before completion of at least one full growing season after seeding.

Species to be planted in pounds of pure live seed* per acre:

<u>Species</u>	<u>lb/acre</u>
Plains lovegrass (<i>Eragrostis intermedia</i>)	0.5
Sand dropseed (<i>Sporobolus cryptandrus</i>)	1.0
Sideoats grama (<i>Bouteloua curtipendula</i>)	5.0
Plains bristlegrass (<i>Setaria macrostachya</i>)	2.0

*Pounds of pure live seed:

Pounds of seed x percent purity x percent germination = pounds pure live seed