

District I
1625 N. French Dr., Hobbs, NM 88240
Phone: (575) 393-6161 Fax: (575) 393-0720

District II
811 S. First St., Artesia, NM 88210
Phone: (575) 748-1283 Fax: (575) 748-9720

District III
1000 Rio Brazos Road, Aztec, NM 87410
Phone: (505) 334-6178 Fax: (505) 334-6170

District IV
1220 S. St. Francis Dr., Santa Fe, NM 87505
Phone: (505) 476-3460 Fax: (505) 476-3462

State of New Mexico
Energy Minerals and Natural Resources
NEW MEXICO CONSERVATION

Form C-101
Revised July 18, 2013

Oil Conservation Division
1220 South St. Francis Dr.

ARTESIA DISTRICT

AMENDED Report

AUG 6 2015

Santa Fe, NM 87505

RECEIVED

APPLICATION FOR PERMIT TO DRILL, RE-ENTER, DEEPEN, PLUGBACK, OR ADD A ZONE

¹ Operator Name and Address Lime Rock Resources II-A, L.P. 1111 Bagby Street, Suite 4600 Houston, Texas 77002		² OGRID Number 277558
		³ Well Number 30-015-43301
⁴ Property Code 39002	⁵ Property Name Kaiser 7 K	⁶ Well No. #4

⁷ Surface Location

UL - Lot	Section	Township	Range	Lot Idn	Feet From	N/S Line	Feet From	E/W Line	County
K	7	18S	27E		2140	S	1475	W	Eddy

⁸ Proposed Bottom Hole Location

UL - Lot	Section	Township	Range	Lot Idn	Feet From	N/S Line	Feet From	E/W Line	County
K	7	18S	27E		2310	S	1650	W	Eddy

⁹ Pool Information

Red Lake; Glorieta-Yeso	51120
-------------------------	-------

Additional Well Information

⁹ Work Type N	¹⁰ Well Type O	¹¹ Cable/Rotary R	¹² Lease Type P	¹³ Ground Level Elevation 3291.7
¹⁴ Multiple N	¹⁵ Proposed Depth 4700' MD / 4700' TVD	¹⁶ Formation Yeso	¹⁷ Contractor United Drilling, Inc.	¹⁸ Snud Date After 6/1/2015
Depth to Ground Water: 8 Ft.		Distance from nearest fresh water well: 0.31 Miles		Distance from nearest surface water: 0.08 Miles

We will be using a closed-loop system in lieu of lined pits

¹⁹ Proposed Casing and Cement Program

Type	Hole Size	Casing Size	Casing Weight/ft	Setting Depth	Sacks of Cement	Estimated TOC
Conductor	26"	20"	91.5	60	60	Surface
Surface	12-1/4"	8-5/8"	24	425	350	Surface
Production	7-7/8"	5-1/2"	17	4700	870	Surface

Casing/Cement Program: Additional Comments

--

Proposed Blowout Prevention Program

Type	Working Pressure	Test Pressure	Manufacturer
XLT 11"	5000	2000	National Varco

I hereby certify that the information given above is true and complete to the best of my knowledge and belief.

I further certify that I have complied with 19.15.14.9 (A) NMAC and/or 19.15.14.9 (B) NMAC 0, if applicable.

Signature: *Spencer Cox*

Printed Name: Spencer Cox

Title: Production Engineer

E-mail Address: scox@limerockresources.com

Date: 5/20/2015

Phone: 713-292-9528

OIL CONSERVATION DIVISION

Approved By:

AR Dade

Title:

Dist H. Spewison

Approved Date:

8/14/2015

Expiration Date:

8/14/2017

Conditions of Approval Attached

District I
1625 N. French Dr., Hobbs, NM 88240
District II
1301 W. Grand Avenue, Artesia, NM 88210
District III
1000 Rio Brazos Rd., Aztec, NM 87410
District IV
1220 S. St. Francis Dr., Santa Fe, NM 87505

State of New Mexico
Energy, Minerals & Natural Resources Department
OIL CONSERVATION DIVISION
1220 South St. Francis Dr.
Santa Fe, NM 87505

Form C-102
Revised October 15, 2009
Submit one copy to appropriate
District Office
 AMENDED REPORT

WELL LOCATION AND ACREAGE DEDICATION PLAT

¹ API Number 30-015-43301		² Pool Code 51120		³ Pool Name Dad Laha Gloriaeta Yeso	
⁴ Property Code 39002		⁵ Property Name KAISER "7" K			⁶ Well Number 4
⁷ OGRID No. 277558		⁸ Operator Name LIME ROCK RESOURCES II A, LP			⁹ Elevation 3291.7

¹⁰ Surface Location

UL or lot no.	Section	Township	Range	Lot Idn	Feet from the	North/South line	Feet from the	East/West line	County
K	7	18 S	27 E		2140	SOUTH	1475	WEST	EDDY

¹¹ Bottom Hole Location If Different From Surface

UL or lot no.	Section	Township	Range	Lot Idn	Feet from the	North/South line	Feet from the	East/West line	County
K	7	18 S	27 E		2310	SOUTH	1650	WEST	EDDY

¹² Dedicated Acres 40	¹³ Joint or Infill	¹⁴ Consolidation Code	¹⁵ Order No.
-------------------------------------	-------------------------------	----------------------------------	-------------------------

No allowable will be assigned to this completion until all interests have been consolidated or a non-standard unit has been approved by the division.

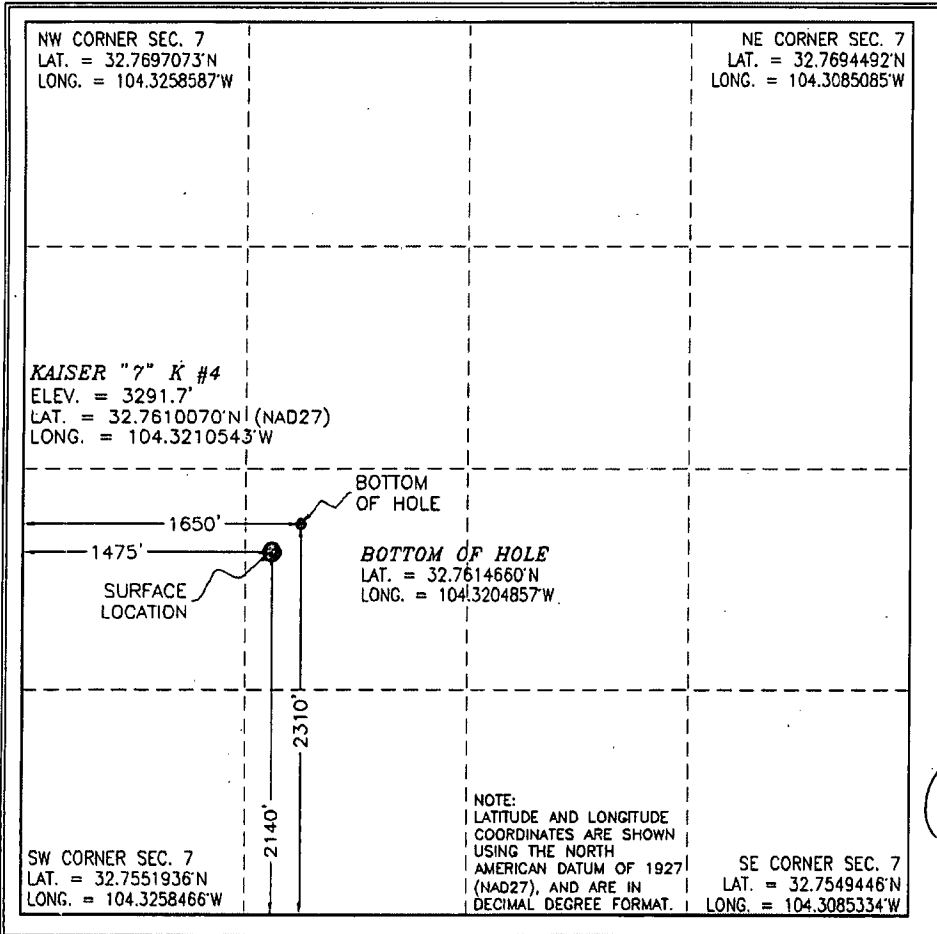

¹⁷ OPERATOR CERTIFICATION
I hereby certify that the information contained herein is true and complete to the best of my knowledge and belief, and that this organization either owns a working interest or unleased mineral interest in the land including the proposed bottom hole location or has a right to drill this well at this location pursuant to a contract with an owner of such a mineral or working interest, or to a voluntary pooling agreement or a compulsory pooling order heretofore entered by the division.

Signature: *Spencer Cox* Date: 5-20-15

Printed Name: Spencer Cox

¹⁸ SURVEYOR CERTIFICATION
I hereby certify that the well location shown on this plat was plotted from field notes of actual surveys made by me or under my supervision, and that the same is true and correct to the best of my belief.

Date of Survey: JANUARY 26, 2012

Signature and Seal of Professional Surveyor: *Filimon F. Jaramillo*

Certificate Number: FILIMON F. JARAMILLO, PLS 12797
SURVEY NO. 798

SECTION 7, TOWNSHIP 18 SOUTH, RANGE 27 EAST, N.M.P.M.
 EDDY COUNTY, STATE OF NEW MEXICO

NOTE: THE LATITUDE AND LONGITUDE COORDINATES ARE SHOWN USING THE NORTH AMERICAN DATUM OF 1927 (NAD27), AND ARE IN DECIMAL DEGREE FORMAT.

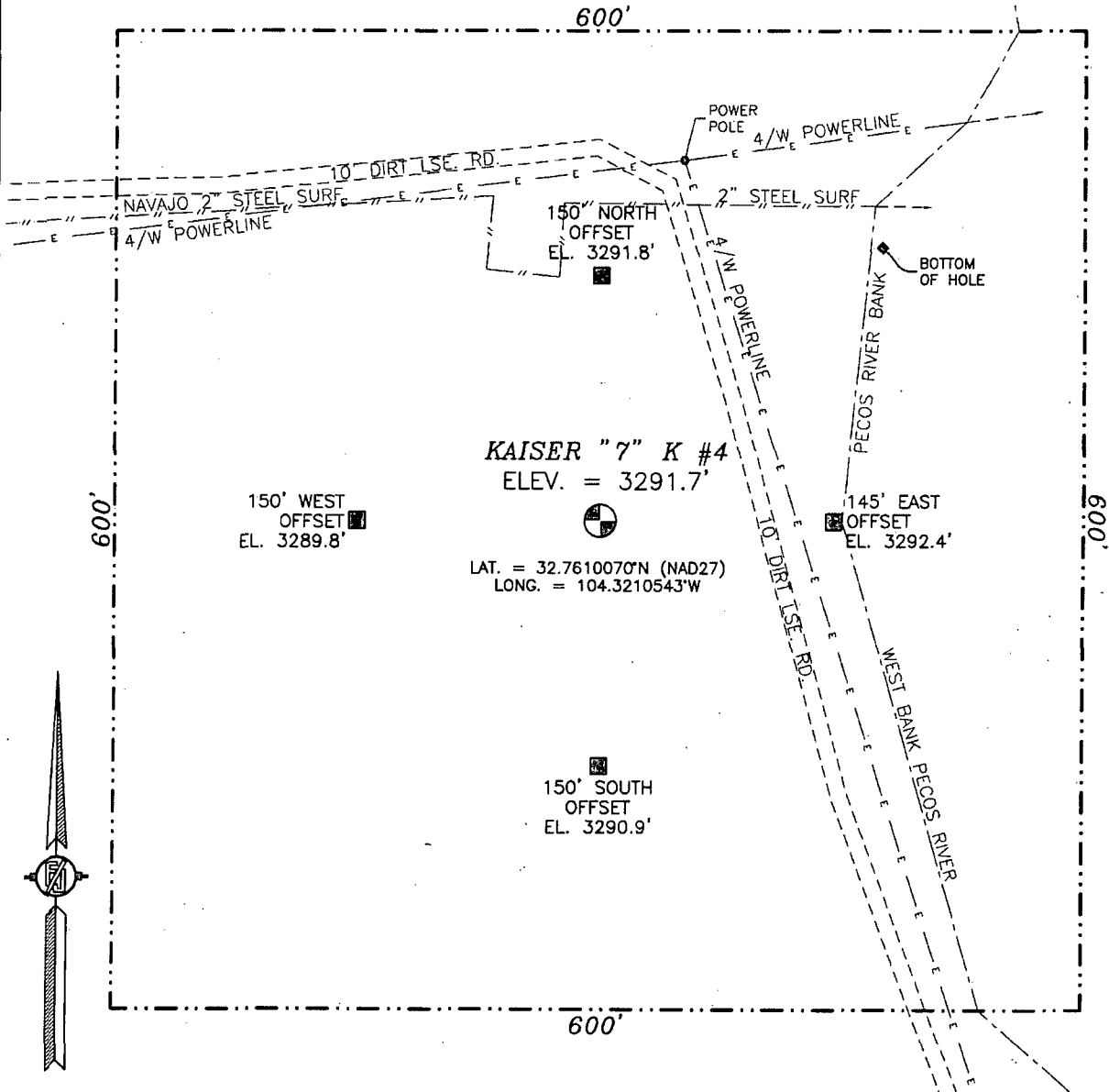

0 10 50 100 200

SCALE 1" = 100'

DIRECTIONS TO LOCATION

FROM PAVED CR. #34 (LAKE RD.) AND PAVED CR. #39 (FOUR DINKUS) GO EAST ON CR. #39 1.7 MILES AND CONTINUE EAST ON CALICHE ROAD 1.0 MILES, BEND LEFT AND GO NE 0.4 MILES, BEND RIGHT AND GO EAST 0.2 MILES, TURN LEFT AND GO NORTH 0.2 MILES AND LOCATION IS ON THE LEFT (WEST) 135'.

LIME ROCK RESOURCES II A, LP
KAISER "7" K #4
 LOCATED 2140' FT. FROM THE SOUTH LINE
 AND 1475 FT. FROM THE WEST LINE OF
 SECTION 7, TOWNSHIP 18 SOUTH,
 RANGE 27 EAST, N.M.P.M.
 EDDY COUNTY, STATE OF NEW MEXICO

JANUARY, 26, 2012

SURVEY NO. 798

MADRON SURVEYING, INC. 301 SOUTH CANAL (575) 234-3341 CARLSBAD, NEW MEXICO

SECTION 7, TOWNSHIP 18 SOUTH, RANGE 27 EAST, N.M.P.M.
 EDDY COUNTY, STATE OF NEW MEXICO
 VICINITY MAP

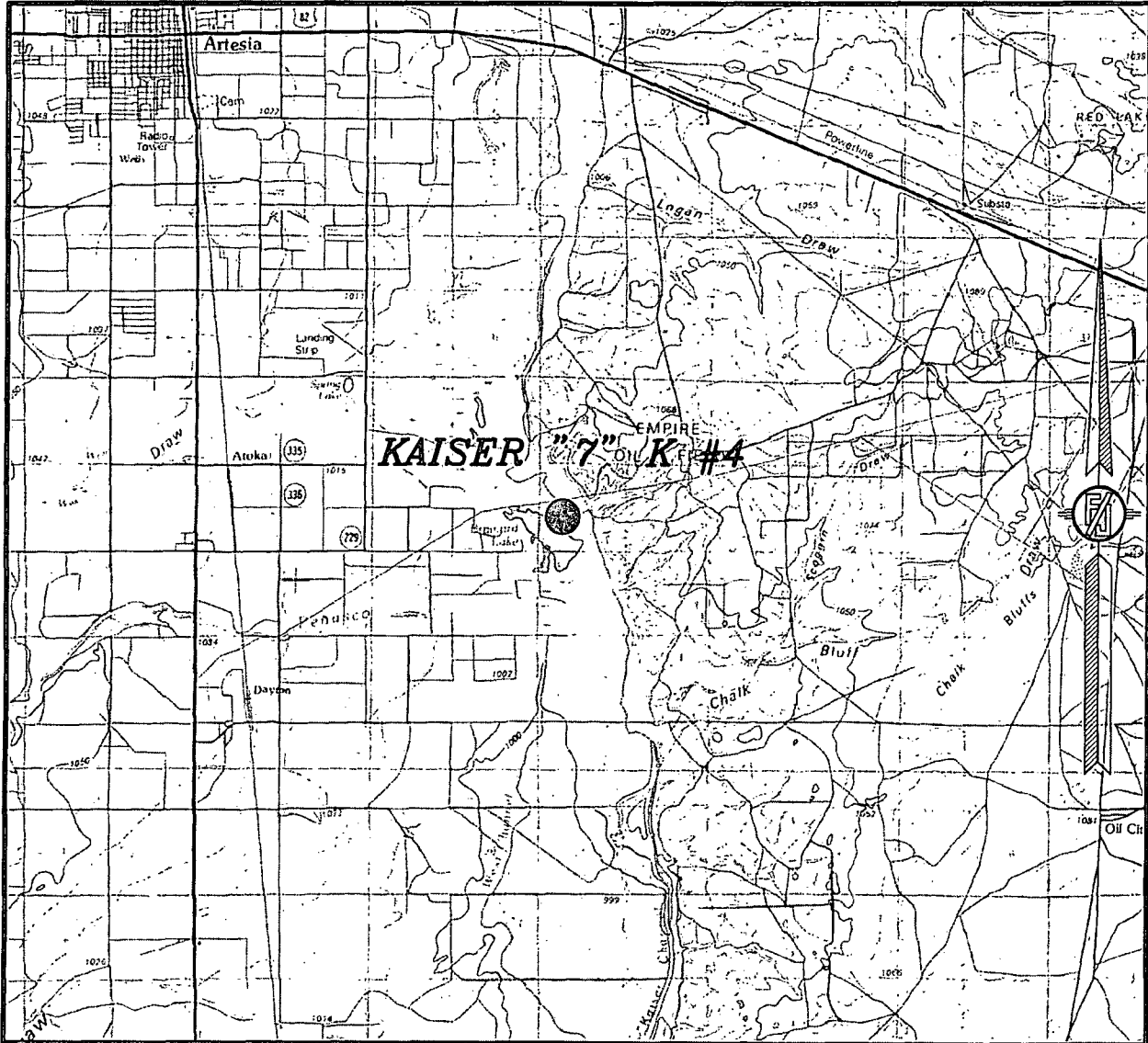

NOT TO SCALE

LIME ROCK RESOURCES II A, LP
KAISER "7" K #4
 LOCATED 2140' FT. FROM THE SOUTH LINE
 AND 1475 FT. FROM THE WEST LINE OF
 SECTION 7, TOWNSHIP 18 SOUTH,
 RANGE 27 EAST, N.M.P.M.
 EDDY COUNTY, STATE OF NEW MEXICO

JANUARY, 26, 2012

SURVEY NO. 798

MADRON SURVEYING, INC. 301 SOUTH CANAL CARLSBAD, NEW MEXICO
 (575) 234-3341

SECTION 7, TOWNSHIP 18 SOUTH, RANGE 27 EAST, N.M.P.M.
 EDDY COUNTY, STATE OF NEW MEXICO
 LOCATION VERIFICATION MAP

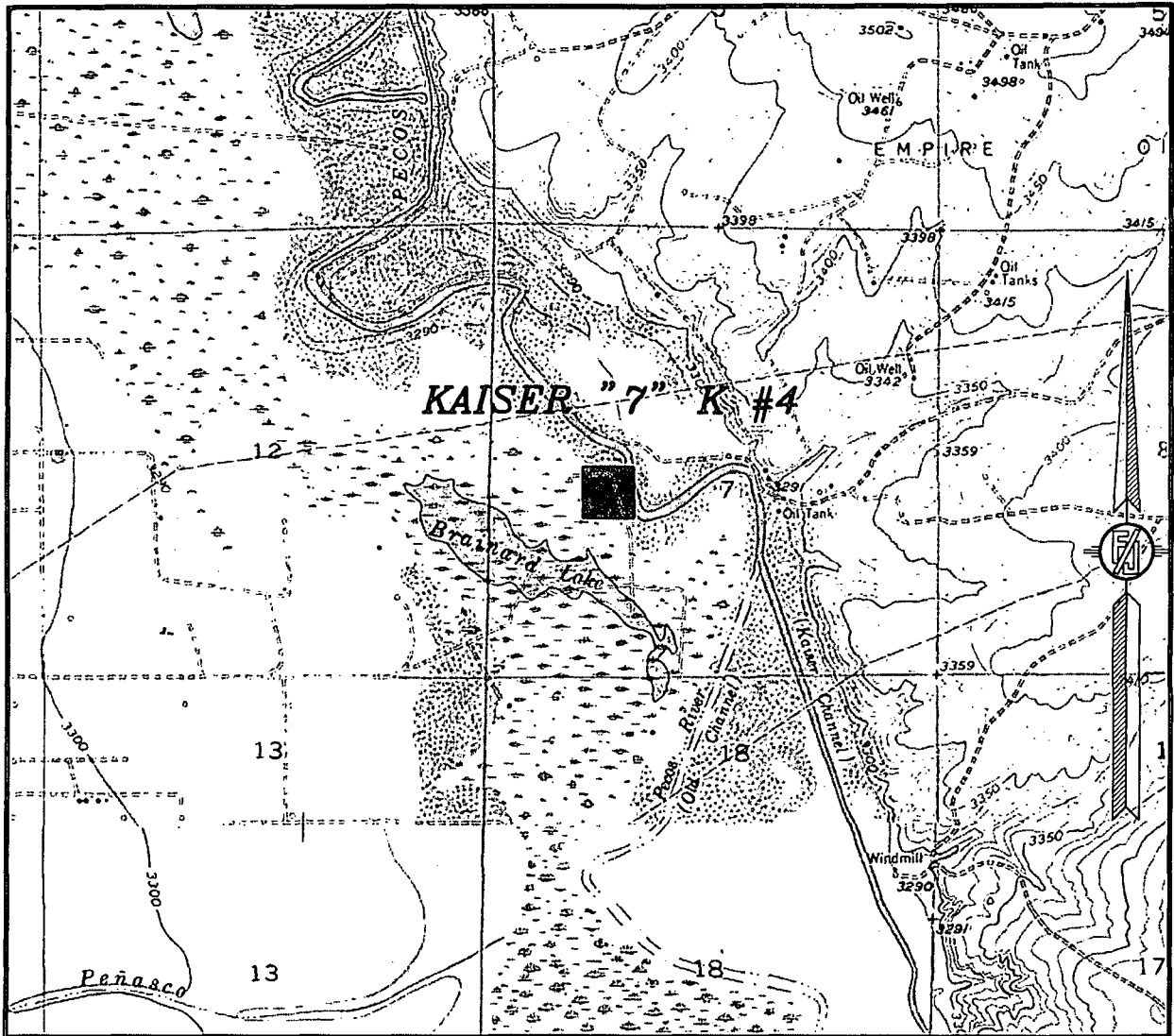

USGS QUAD MAP:
 SPRING LAKE

NOT TO SCALE

LIME ROCK RESOURCES II A, LP
 KAISER "7" K #4
 LOCATED 2140' FT. FROM THE SOUTH LINE
 AND 1475 FT. FROM THE WEST LINE OF
 SECTION 7, TOWNSHIP 18 SOUTH,
 RANGE 27 EAST, N.M.P.M.
 EDDY COUNTY, STATE OF NEW MEXICO

JANUARY, 26, 2012

SURVEY NO. 798

MADRON SURVEYING, INC. 301 SOUTH CANAL CARLSBAD, NEW MEXICO
 (575) 234-3341

SECTION 7, TOWNSHIP 18 SOUTH, RANGE 27 EAST, N.M.P.M.
EDDY COUNTY, STATE OF NEW MEXICO
AERIAL PHOTO

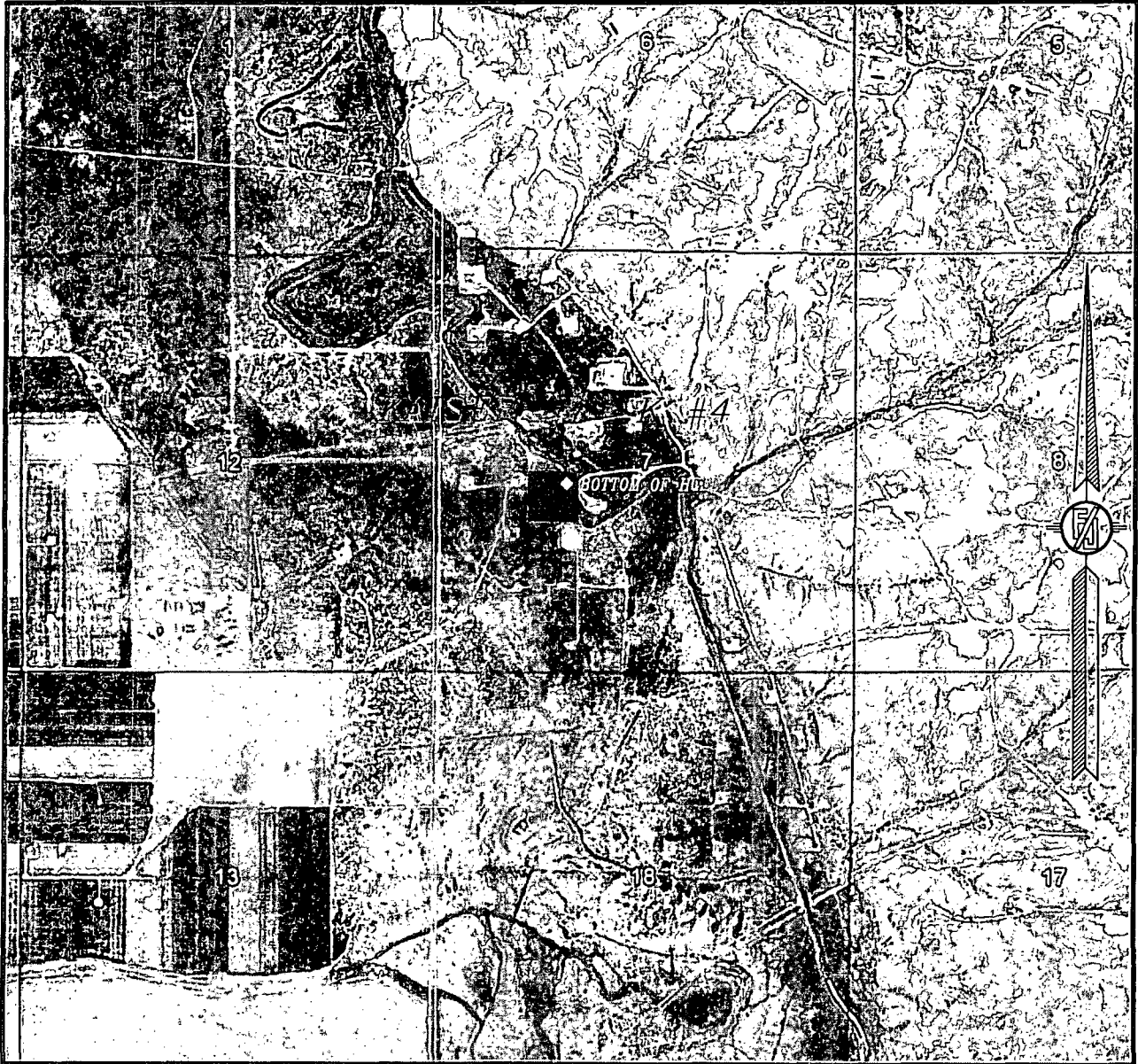

NOT TO SCALE
AERIAL PHOTO:
GOOGLE EARTH
JUNE, 2011

LIME ROCK RESOURCES II A, LP
KAISER "7" K #4
LOCATED 2140' FT. FROM THE SOUTH LINE
AND 1475 FT. FROM THE WEST LINE OF
SECTION 7, TOWNSHIP 18 SOUTH,
RANGE 27 EAST, N.M.P.M.
EDDY COUNTY, STATE OF NEW MEXICO

SURVEY NO. 798

JANUARY, 26, 2012

MADRON SURVEYING, INC. 301 SOUTH CANAL CARLSBAD, NEW MEXICO
(575) 234-3341

**Lime Rock Resources II-A, L.P.
Drilling Plan**

**Kaiser 7 K #4
2140' FSL 1475' FWL
(K) 7-18S-27E
Eddy County, NM**

1. The elevation of the unprepared ground is 3291.7 feet above sea level.
2. The geologic name of the surface formation is Quaternary – Alluvium.
3. A rotary rig will be utilized to drill the well to 4700' and run casing. This equipment will be rigged down and the well will be completed with a workover rig.
4. Well will be drilled to a total proposed depth of 4700' MD./ 4700' TVD. inside a 30' X 30' square target inside of 40 acre spacing regulatory quarter-quarter setback distances. The KOP for directional drilling will be at '. See directional plan for detail.
5. Estimated tops of geologic markers:

	MD	TVD
Quaternary – Alluvium	Surface	Surface
Yates	NA	NA
7 Rivers	20	20
Queen	365	365
Grayburg	1355	1355
Premier	NA	NA
San Andres	1032	1032
Glorieta	2364	2364
Yeso	2522	2522
Tubb	4035	4035
TD	4700	4700

6. Estimated depths at which anticipated oil, gas, or other mineral bearing formations are expected to be encountered:

	MD	TVD
Yates	NA	NA
7 Rivers	20	20
Queen	365	365
Grayburg	1355	1355
Premier	NA	NA
San Andres	1032	1032
Glorieta	2364	2364
Yeso	2522	2522
Tubb	4035	4035
TD	4700	4700

7. Proposed Casing and Cement program is as follows:

Type	Hole	Casing	Wt	Grade	Thread	Depth	Sx	Density	Yield	Components
Conductor	26"	20"	91.5	B	Welded	60	60			Ready Mix
Surface	12-1/4"	8-5/8"	24	J-55	ST&C	425	350	14.8	1.35	Cl C Cmt + 0.25 lbs/sk Cello Flake + 2% CaCl ₂
Intermediate										
Production	7-7/8"	5-1/2"	17	J-55	LT&C	4700	200	12.8	1.903	(35:65) Poz/Cl C Cmt + 5% NaCl + 0.25 lbs/sk Cello Flake + 5 lbs/sk LCM-1 +0.2% R-3 + 6% Gel
							670	14.8	1.33	Class C w/ 0.6% R-3 and 1/4 pps cello flake

8. Proposed Mud Program is as follows

Depth	0-425	425-4550	4550-4700
Mud Type	Fresh Water Mud	Brine	Brine, Salt Gel, & Starch
Properties			
MW	8.4-9.2	9.8-10.1	9.9-10.1
pH	9.0-10.5	10.0-12.0	10.0-12.0
WL	NC	NC	20-30
Vis	28-34	28-29	32-34
MC	NC	NC	<2
Solids	NC	<2%	<3%
Pump Rate	300-500 gpm	375-425 gpm	400-425 gpm
Special		Use Poymers sticks and MF-55 Hi-Vis Sweeps as necessary	Hi Vis Sweeps, add acid and starch as req. Raise Vis to 35 for log.

9. **Pressure Control Equipment: See Attached Description and diagram of Pressure Control Equipment.**

10. **Testing, Logging and Coring Program**

Testing Program: No drill stem tests are anticipated

Electric Logging Program: SGR-DLL-CDL-CNL Quad Combo from 4700 to surf. Csg. SGR-CNL to Surf.

Coring Program: No full or sidewall cores are anticipated.

11. **Potential Hazards:**

No abnormal temperatures or pressures are expected. There is no known presence of H₂S in this area. If H₂S is encountered the operator will comply with the provisions of Onshore Oil and Gas Order No. 6. All personnel will be familiar with all aspects of safe operation of equipment being used to drill this well.

Estimated BHP 2068 psi based on 0.44 x TD. The estimated BHT is 125 degrees F.

12. **Duration of Operations:**

Anticipated spud date will be soon after approval and as soon as a rig will be available. Move in operations and drilling is expected to take 10 days. An additional 14 days will be needed it complete the well and to construct surface facilities.

LIME ROCK RESOURCES

EDDY COUNTY, NM (NAD 27)

SEC. 7 T18S RGE. 27E

KAISER "7" K #4

ORIGINAL WELLBORE

20 March, 2012

Plan: PROPOSAL #2



Project: EDDY COUNTY, NM (NAD 27)
 Site: SEC. 7 T18S RGE. 27E
 Well: KAISER "7" K #4
 Wellbore: ORIGINAL WELLBORE
 Design: PROPOSAL #2

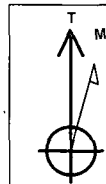
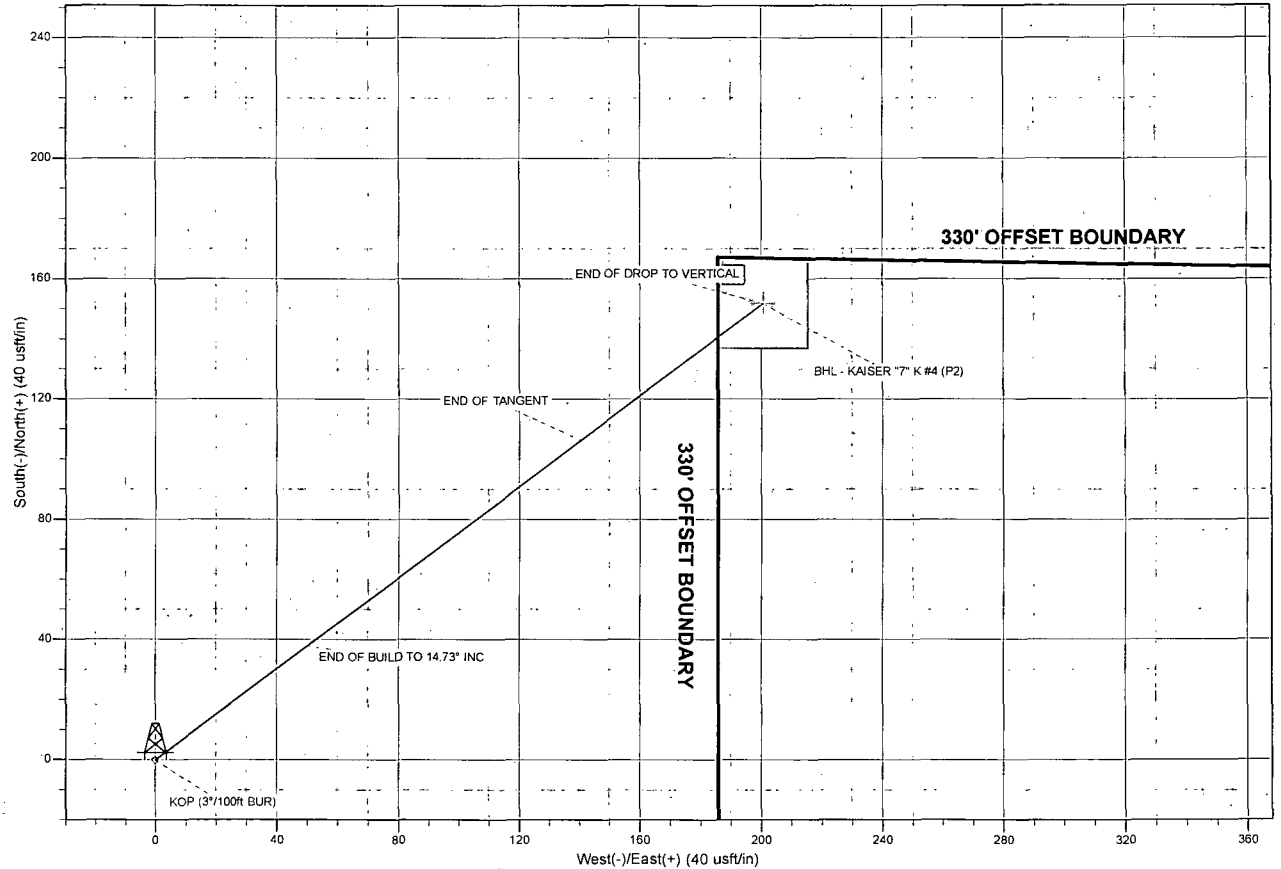
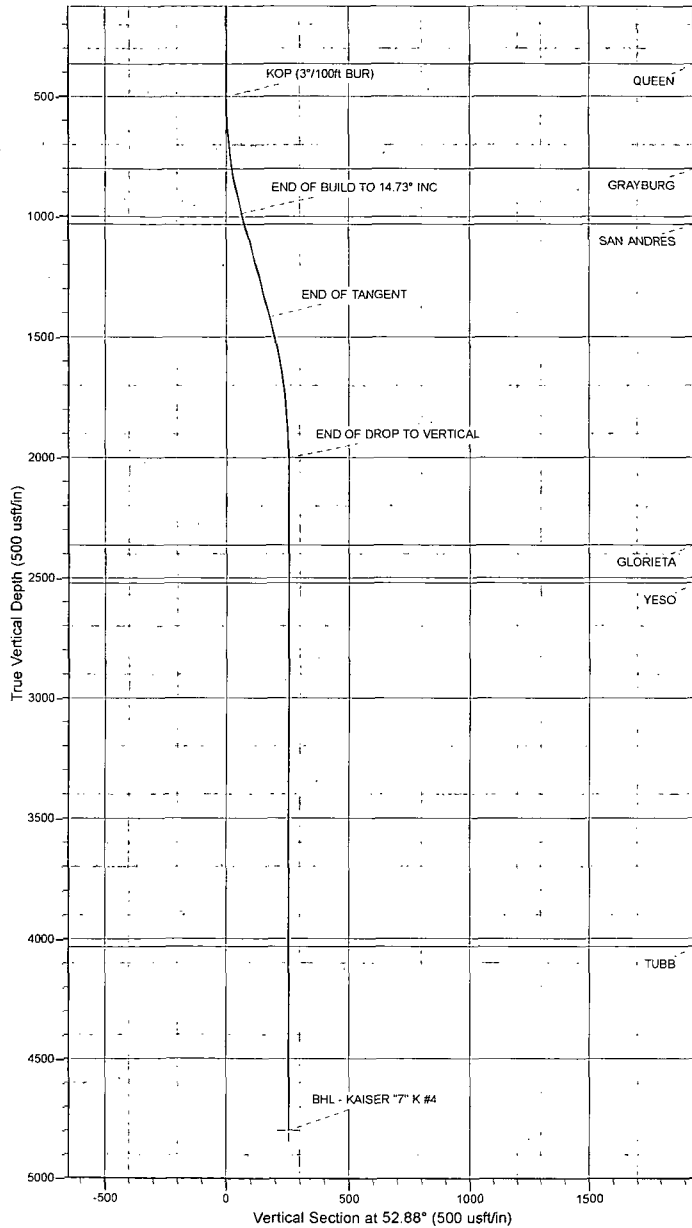

Azimuths to True North
 Magnetic North: 7.88°

Magnetic Field
 Strength: 48780.2snT
 Dip Angle: 60.53°
 Date: 20/03/2012
 Model: IGRF2010

ANNOTATIONS

TVD	MD	Inc	Azi	+N-S	+E/-W	Vsect	Annotation
500.0	500.0	0.00	0.00	0.0	0.0	0.0	KOP (3"/100ft BUR)
985.5	990.9	14.73	52.88	37.9	50.0	62.7	END OF BUILD TO 14.73° INC
1417.3	1437.4	14.73	52.88	106.4	140.6	176.3	END OF TANGENT
2000.0	2026.5	0.00	52.88	151.8	200.6	251.6	END OF DROP TO VERTICAL
4800.0	4826.5	0.00	0.00	151.8	200.6	251.6	BHL - KAISER "7" K #4



Database:	EDM_5000_1_7	Local Co-ordinate Reference:	Well KAISER "7" K #4
Company:	LIME ROCK RESOURCES	TVD Reference:	KB-EST @ 3305.1usft (Original Well Elev)
Project:	EDDY COUNTY, NM (NAD 27)	MD Reference:	KB-EST @ 3305.1usft (Original Well Elev)
Site:	SEC. 7 T18S RGE. 27E	North Reference:	True
Well:	KAISER "7" K #4	Survey Calculation Method:	Minimum Curvature
Wellbore:	ORIGINAL WELLBORE		
Design:	PROPOSAL #2		

Project	EDDY COUNTY, NM (NAD 27)		
Map System:	US State Plane 1927 (Exact solution)	System Datum:	Mean Sea Level
Geo Datum:	NAD 1927 (NADCON CONUS)		
Map Zone:	New Mexico East 3001		Using geodetic scale factor

Site	SEC. 7 T18S RGE. 27E				
Site Position:		Northing:	640,565.51 usft	Latitude:	32° 45' 39.625 N
From:	Lat/Long	Easting:	503,774.66 usft	Longitude:	104° 19' 15.795 W
Position Uncertainty:	0.0 usft	Slot Radius:	13-3/16"	Grid Convergence:	0.01 °

Well	KAISER "7" K #4					
Well Position	+N/-S	0.0 usft	Northing:	640,565.51 usft	Latitude:	32° 45' 39.625 N
	+E/-W	0.0 usft	Easting:	503,774.66 usft	Longitude:	104° 19' 15.795 W
Position Uncertainty		0.0 usft	Wellhead Elevation:	usft	Ground Level:	3,291.7 usft

Wellbore	ORIGINAL WELLBORE				
-----------------	-------------------	--	--	--	--

Magnetics	Model Name	Sample Date	Declination (°)	Dip Angle (°)	Field Strength (nT)
	IGRF2010	20/03/2012	7.88	60.53	48,780

Design	PROPOSAL #2				
---------------	-------------	--	--	--	--

Audit Notes:					
Version:		Phase:	PROTOTYPE	Tie On Depth:	0.0
Vertical Section:	Depth From (TVD) (usft)	+N/-S (usft)	+E/-W (usft)	Direction (°)	
	0.0	0.0	0.0	52.88	

Plan Sections											
MD (usft)	Inc (°)	Azi (°)	Vertical Depth	SS (usft)	+N/-S (usft)	+E/-W (usft)	Dogleg Rate (°/100usft)	Build Rate (°/100usft)	Turn Rate (°/100usft)	TFO (°)	Target
0.0	0.00	0.00	0.0	-3,305.1	0.0	0.0	0.00	0.00	0.00	0.00	
500.0	0.00	0.00	500.0	-2,805.1	0.0	0.0	0.00	0.00	0.00	0.00	
990.9	14.73	52.88	985.6	-2,319.5	37.9	50.0	3.00	3.00	0.00	52.88	
1,437.4	14.73	52.88	1,417.3	-1,887.8	106.4	140.6	0.00	0.00	0.00	0.00	
2,026.5	0.00	0.00	2,000.0	-1,305.1	151.8	200.6	2.50	-2.50	0.00	180.00	
4,826.5	0.00	0.00	4,800.0	1,494.9	151.8	200.6	0.00	0.00	0.00	0.00	BHL - KAISER "7" †

Database:	EDM_5000_1_7	Local Co-ordinate Reference:	Well KAISER "7" K #4
Company:	LIME ROCK RESOURCES	TVD Reference:	KB-EST @ 3305.1usft (Original Well Elev)
Project:	EDDY COUNTY, NM (NAD 27)	MD Reference:	KB-EST @ 3305.1usft (Original Well Elev)
Site:	SEC. 7 T18S RGE. 27E	North Reference:	True
Well:	KAISER "7" K #4	Survey Calculation Method:	Minimum Curvature
Wellbore:	ORIGINAL WELLBORE		
Design:	PROPOSAL #2		

Planned Survey

MD (usft)	Inc (°)	Azi (°)	TVD (usft)	SS (usft)	+N/-S (usft)	+E/-W (usft)	Vertical Section (usft)	Dogleg Rate (°/100usft)	Build Rate (°/100usft)	Turn Rate (°/100usft)
0.0	0.00	0.00	0.0	3,305.10	0.0	0.0	0.0	0.00	0.00	0.00
7 RIVERS										
20.0	0.00	0.00	20.0	3,285.10	0.0	0.0	0.0	0.00	0.00	0.00
100.0	0.00	0.00	100.0	3,205.10	0.0	0.0	0.0	0.00	0.00	0.00
200.0	0.00	0.00	200.0	3,105.10	0.0	0.0	0.0	0.00	0.00	0.00
300.0	0.00	0.00	300.0	3,005.10	0.0	0.0	0.0	0.00	0.00	0.00
QUEEN										
365.0	0.00	0.00	365.0	2,940.10	0.0	0.0	0.0	0.00	0.00	0.00
400.0	0.00	0.00	400.0	2,905.10	0.0	0.0	0.0	0.00	0.00	0.00
KOP (3°/100ft BUR)										
500.0	0.00	0.00	500.0	2,805.10	0.0	0.0	0.0	0.00	0.00	0.00
600.0	3.00	52.88	600.0	2,705.15	1.6	2.1	2.6	3.00	3.00	0.00
700.0	6.00	52.88	699.6	2,605.47	6.3	8.3	10.5	3.00	3.00	0.00
800.0	9.00	52.88	798.8	2,506.33	14.2	18.8	23.5	3.00	3.00	0.00
GRAYBURG										
801.2	9.04	52.88	800.0	2,505.10	14.3	18.9	23.7	3.00	3.00	0.00
900.0	12.00	52.88	897.1	2,408.02	25.2	33.3	41.7	3.00	3.00	0.00
END OF BUILD TO 14.73° INC										
990.9	14.73	52.88	985.5	2,319.59	37.9	50.0	62.7	3.00	3.00	0.00
1,000.0	14.73	52.88	994.3	2,310.79	39.3	51.9	65.1	0.02	0.02	0.00
SAN ANDRES										
1,039.0	14.73	52.88	1,032.0	2,273.10	45.2	59.8	75.0	0.00	0.00	0.00
1,100.0	14.73	52.88	1,091.0	2,214.07	54.6	72.2	90.5	0.00	0.00	0.00
1,200.0	14.73	52.88	1,187.7	2,117.36	69.9	92.4	115.9	0.00	0.00	0.00
1,300.0	14.73	52.88	1,284.5	2,020.64	85.3	112.7	141.3	0.00	0.00	0.00
1,400.0	14.73	52.88	1,381.2	1,923.93	100.6	133.0	166.8	0.00	0.00	0.00
END OF TANGENT										
1,437.4	14.73	52.88	1,417.3	1,887.76	106.4	140.6	176.3	0.00	0.00	0.00
1,500.0	13.16	52.88	1,478.1	1,827.01	115.5	152.6	191.3	2.50	-2.50	0.00
1,600.0	10.66	52.88	1,575.9	1,729.17	127.9	169.0	212.0	2.50	-2.50	0.00
1,700.0	8.16	52.88	1,674.6	1,630.52	137.8	182.1	228.3	2.50	-2.50	0.00
1,800.0	5.66	52.88	1,773.8	1,531.26	145.1	191.7	240.4	2.50	-2.50	0.00
1,900.0	3.16	52.88	1,873.5	1,431.56	149.7	197.8	248.1	2.50	-2.50	0.00
2,000.0	0.66	52.88	1,973.5	1,331.62	151.7	200.5	251.4	2.50	-2.50	0.00
END OF DROP TO VERTICAL										
2,026.5	0.00	52.88	2,000.0	1,305.13	151.8	200.6	251.6	2.50	-2.50	0.00
2,100.0	0.00	0.00	2,073.5	1,231.63	151.8	200.6	251.6	0.00	0.00	0.00
2,200.0	0.00	0.00	2,173.5	1,131.63	151.8	200.6	251.6	0.00	0.00	0.00
2,300.0	0.00	0.00	2,273.5	1,031.63	151.8	200.6	251.6	0.00	0.00	0.00
GLORIETA										
2,390.5	0.00	0.00	2,364.0	941.10	151.8	200.6	251.6	0.00	0.00	0.00
2,400.0	0.00	0.00	2,373.5	931.63	151.8	200.6	251.6	0.00	0.00	0.00
2,500.0	0.00	0.00	2,473.5	831.63	151.8	200.6	251.6	0.00	0.00	0.00
YESO										
2,548.5	0.00	0.00	2,522.0	783.10	151.8	200.6	251.6	0.00	0.00	0.00
2,600.0	0.00	0.00	2,573.5	731.63	151.8	200.6	251.6	0.00	0.00	0.00
2,700.0	0.00	0.00	2,673.5	631.63	151.8	200.6	251.6	0.00	0.00	0.00
2,800.0	0.00	0.00	2,773.5	531.63	151.8	200.6	251.6	0.00	0.00	0.00
2,900.0	0.00	0.00	2,873.5	431.63	151.8	200.6	251.6	0.00	0.00	0.00
3,000.0	0.00	0.00	2,973.5	331.63	151.8	200.6	251.6	0.00	0.00	0.00
3,100.0	0.00	0.00	3,073.5	231.63	151.8	200.6	251.6	0.00	0.00	0.00
3,200.0	0.00	0.00	3,173.5	131.63	151.8	200.6	251.6	0.00	0.00	0.00
3,300.0	0.00	0.00	3,273.5	31.63	151.8	200.6	251.6	0.00	0.00	0.00

Database:	EDM_5000_1_7	Local Co-ordinate Reference:	Well KAISER "7" K #4
Company:	LIME ROCK RESOURCES	TVD Reference:	KB-EST @ 3305.1usft (Original Well Elev)
Project:	EDDY COUNTY, NM (NAD 27)	MD Reference:	KB-EST @ 3305.1usft (Original Well Elev)
Site:	SEC. 7 T18S RGE. 27E	North Reference:	True
Well:	KAISER "7" K #4	Survey Calculation Method:	Minimum Curvature
Wellbore:	ORIGINAL WELLBORE		
Design:	PROPOSAL #2		

Planned Survey:

MD (usft)	Inc (°)	Azi (°)	TVD (usft)	SS (usft)	+N/-S (usft)	+E/-W (usft)	Vertical Section (usft)	Dogleg Rate (°/100usft)	Build Rate (°/100usft)	Turn Rate (°/100usft)
3,400.0	0.00	0.00	3,373.5	-68.37	151.8	200.6	251.6	0.00	0.00	0.00
3,500.0	0.00	0.00	3,473.5	-168.37	151.8	200.6	251.6	0.00	0.00	0.00
3,600.0	0.00	0.00	3,573.5	-268.37	151.8	200.6	251.6	0.00	0.00	0.00
3,700.0	0.00	0.00	3,673.5	-368.37	151.8	200.6	251.6	0.00	0.00	0.00
3,800.0	0.00	0.00	3,773.5	-468.37	151.8	200.6	251.6	0.00	0.00	0.00
3,900.0	0.00	0.00	3,873.5	-568.37	151.8	200.6	251.6	0.00	0.00	0.00
4,000.0	0.00	0.00	3,973.5	-668.37	151.8	200.6	251.6	0.00	0.00	0.00
TUBB										
4,061.5	0.00	0.00	4,035.0	-729.90	151.8	200.6	251.6	0.00	0.00	0.00
4,100.0	0.00	0.00	4,073.5	-768.37	151.8	200.6	251.6	0.00	0.00	0.00
4,200.0	0.00	0.00	4,173.5	-868.37	151.8	200.6	251.6	0.00	0.00	0.00
4,300.0	0.00	0.00	4,273.5	-968.37	151.8	200.6	251.6	0.00	0.00	0.00
4,400.0	0.00	0.00	4,373.5	-1,068.37	151.8	200.6	251.6	0.00	0.00	0.00
4,500.0	0.00	0.00	4,473.5	-1,168.37	151.8	200.6	251.6	0.00	0.00	0.00
4,600.0	0.00	0.00	4,573.5	-1,268.37	151.8	200.6	251.6	0.00	0.00	0.00
4,700.0	0.00	0.00	4,673.5	-1,368.37	151.8	200.6	251.6	0.00	0.00	0.00
4,800.0	0.00	0.00	4,773.5	-1,468.37	151.8	200.6	251.6	0.00	0.00	0.00
BHL - KAISER "7" K #4										
4,826.5	0.00	0.00	4,800.0	-1,494.87	151.8	200.6	251.6	0.00	0.00	0.00

Formations

MD (usft)	TVD (usft)	Name	Lithology	Dip (°)	Dip Direction (°)
20.0	20.0	7 RIVERS		0.00	
365.0	365.0	QUEEN		0.00	
801.2	800.0	GRAYBURG		0.00	
1,039.0	1,032.0	SAN ANDRES		0.00	
2,390.5	2,364.0	GLORIETA		0.00	
2,548.5	2,522.0	YESO		0.00	
4,061.5	4,035.0	TUBB		0.00	

Plan Annotations

MD (usft)	TVD (usft)	Local Coordinates		Comment
		+N/-S (usft)	+E/-W (usft)	
500.0	500.0	0.0	0.0	KOP (3°/100ft BUR)
990.9	985.5	37.9	50.0	END OF BUILT TO 14.73° INC
1,437.4	1,417.3	106.4	140.6	END OF TANGENT
2,026.5	2,000.0	151.8	200.6	END OF DROP TO VERTICAL
4,826.5	4,800.0	151.8	200.6	BHL - KAISER "7" K #4

Hydrogen Sulfide Drilling Plan Summary

A. All personnel shall receive proper H₂S training in accordance with Onshore Order 6 III.C.3.a.

B. Briefing Area: two perpendicular areas will be designated by signs and readily accessible.

C. Required Emergency Equipment:

1 Well control equipment

- a. Flare line 150' from wellhead to be ignited by flare gun.
- b. Choke manifold with a remotely operated choke.
- c. Mud/gas separator

2 Protective equipment for essential personnel.

Breathing apparatus:

- a. Rescue Packs (SCBA) — 1 unit shall be placed at each breathing area, 2 shall be stored in the safety trailer.
- b. Work/Escape packs — 4 packs shall be stored on the rig floor and contain sufficiently long air hoses as to not to restrict work activity.
- c. Emergency Escape Packs — 4 packs shall be stored in the doghouse for emergency evacuation.

Auxiliary Rescue Equipment:

- a. Stretcher
- b. Two OSHA full body harness
- c. 100 ft 5/8 inch OSHA approved rope
- d. 1-20# class ABC fire extinguisher

3 H₂S detection and monitoring equipment:

The stationary detector with three sensors will be placed in the upper dog house if equipped, set to visually alarm @ 10 ppm and audible @ 14 ppm. Calibrate a minimum of every 30 days or as needed. The sensors will be placed in the following places: Rig floor / Bell nipple / End of flow line or where well bore fluid is being discharged.
(Gas sample tubes will be stored in the safety trailer)

4 Visual warning systems:

- a. One color code condition sign will be placed at the entrance to the site reflecting the possible conditions at the site.
- b. A colored condition flag will be on display, reflecting the current condition at the site at the time.
- c. Two wind socks will be placed in strategic locations, visible from all angles.

5 Mud program:

The mud program has been designed to minimize the volume of H₂S circulated to surface. The operator will have the necessary mud products to minimize hazards while drilling in H₂S bearing zones.

■ Metallurgy:

- a. All drill strings, casings, tubing, wellhead, blowout preventer, drilling spool, kill lines, choke manifold and lines, and valves shall be suitable for H₂S service.
- b. All elastomers used for packing and seals shall be H₂S trim.

■ Communication:

Communication will be via two way radio in emergency and company vehicles. Cell phones and land lines where available.

H2S CONTINGENCY DRILLING PLAN EMERGENCY CONTACTS

Company Offices - Lime Rock Houston Office
 Answering Service (After Hours)
 Artesia, NM Office
 Roswell, NM

713-292-9510
 713-292-9555
 575-748-9724
 575-623-8424

KEY PERSONNEL

Name	Title	Location	Office #	Cell #	Home #
Mike Loudermilk	Operations Manager	Houston	713-292-9526	832-331-7367	Same as Cell
Spencer Cox	Operations Engineer	Houston	713-292-9528	432-254-5140	Same as Cell
Eric McClusky	Operations Engineer	Houston	713-360-5714	405-821-0534	832-491-3079
Jerry Smith	Assistant Production Supervisor	Artesia	575-748-9724	505-918-0556	575-746-2478
Michael Barrett	Production Supervisor	Roswell	575-623-8424	505-353-2644	575-623-4707
Gary McClland	Well Site Supervisor	Rotates on Site	NA	903-503-8997	NA
Dave Williamson	Well Site Supervisor	Rotates on Site	NA	575-308-9980	NA

Agency Call List

City	Agency or Office	Telephone #
Artesia	Ambulance	911
Artesia	State Police	575-746-2703
Artesia	Sherriff's Office	575-746-9888
Artesia	City Police	575-746-2703
Artesia	Fire Department	575-746-2701
Artesia	Local Emergency Planning Committee	575-746-2122
Artesia	New Mexico OCD District II	575-748-1283
Carlsbad	Ambulance	911
Carlsbad	State Police	575-885-3137
Carlsbad	Sherriff's Office	575-887-7551
Carlsbad	City Police	575-885-2111
Carlsbad	Fire Department	575-885-2111
Carlsbad	Local Emergency Planning Committee	575-887-3798
Carlsbad	US DOI Bureau of Land Management	575-887-6544
State Wide	New Mexico Emergency Response Commisssion ("NMERC")	505-476-9600
State Wide	NMERC 24 Hour Number	505-827-9126
State Wide	New Mexico State Emergency Operations Center	505-476-9635
National	National Emergency Response Center (Washington D.C.)	800-424-8802

Emergency Services

Name	Service	Location	Telephone Number	Alternate Number
Boots & Coots International Well Control	Well Control	Houston / Odessa	1-800-256-9688	281-931-8884
Cudd Pressure Control	Well Control/Pumping	Odessa	915-699-0139	915-563-3356
Baker Hughes Inc.	Pumping Services	Artesia, Hobbs & Odessa	575-746-2757	Same
Total Safety	Safety Equipment & Personnel	Artesia	575-746-2847	Same
Cutter Oilfield Services	Drilling Systems Equipment	Midland	432-488-6707	Same
Safety Dog	Safety Equipment & Personnel	Artesia	575-748-5847	575-441-1370
Fighting for Life	Emergency Helicopter Evacuation	Lubbock	806-743-9911	Same
Aerocare	Emergency Helicopter Evacuation	Lubbock	806-747-8923	Same
Med Flight Air Ambulance	Emergency Helicopter Evacuation	Albuquerque	505-842-4433	Same
Artesia General Hospital	Emergency Medical Care	Artesia	575-748-3333	702 North 13th Street

Pressure Control Equipment

The blowout preventer equipment (BOP) will consist of a 5000 psi rated, "XLT" type, National VARCO double ram preventer that will be tested to a maximum pressure of 2000 psi. The unit will be hydraulically operated and the ram type preventer will be equipped with blind rams on top and drill pipe rams on bottom. The 2M BOP will be installed on the 8 5/8" surface casing and utilized continuously until total depth is reached. All casing strings will be tested as per Onshore Order #2. This also includes a thirty day (30) test, should the rig still be operating on the same well in thirty days.

Pipe rams will be operated and checked each 24 hour period and each time the drill pipe is out of the hole. These functional tests will be documented on the daily drilling logs.

The BOP equipment will consist of the following:-

- Double ram with blind rams (top) and pipe rams (bottom),
- Drilling spool, or blowout preventer with 2 side outlets (choke side shall be a 2" minimum diameter, kill side will be at least 2 inch diameter),
- Kill line (2 inch minimum),
- A minimum of 2 choke line valves (2 inch minimum),
- 2 inch diameter choke line,
- 2 kill valves, one of which will be a check valve (2 inch minimum),
- 2 chokes, one of which will be capable of remote operation,
- Pressure gauge on choke manifold,
- Upper Kelly cock valve with handle available,
- Safety valve and subs to fit all drill string connections in use,
- All BOPE connections subjected to well pressure will be flanged, welded, or clamped,
- A Fill-up line above the uppermost preventer.

2M BOP SCHEMATIC

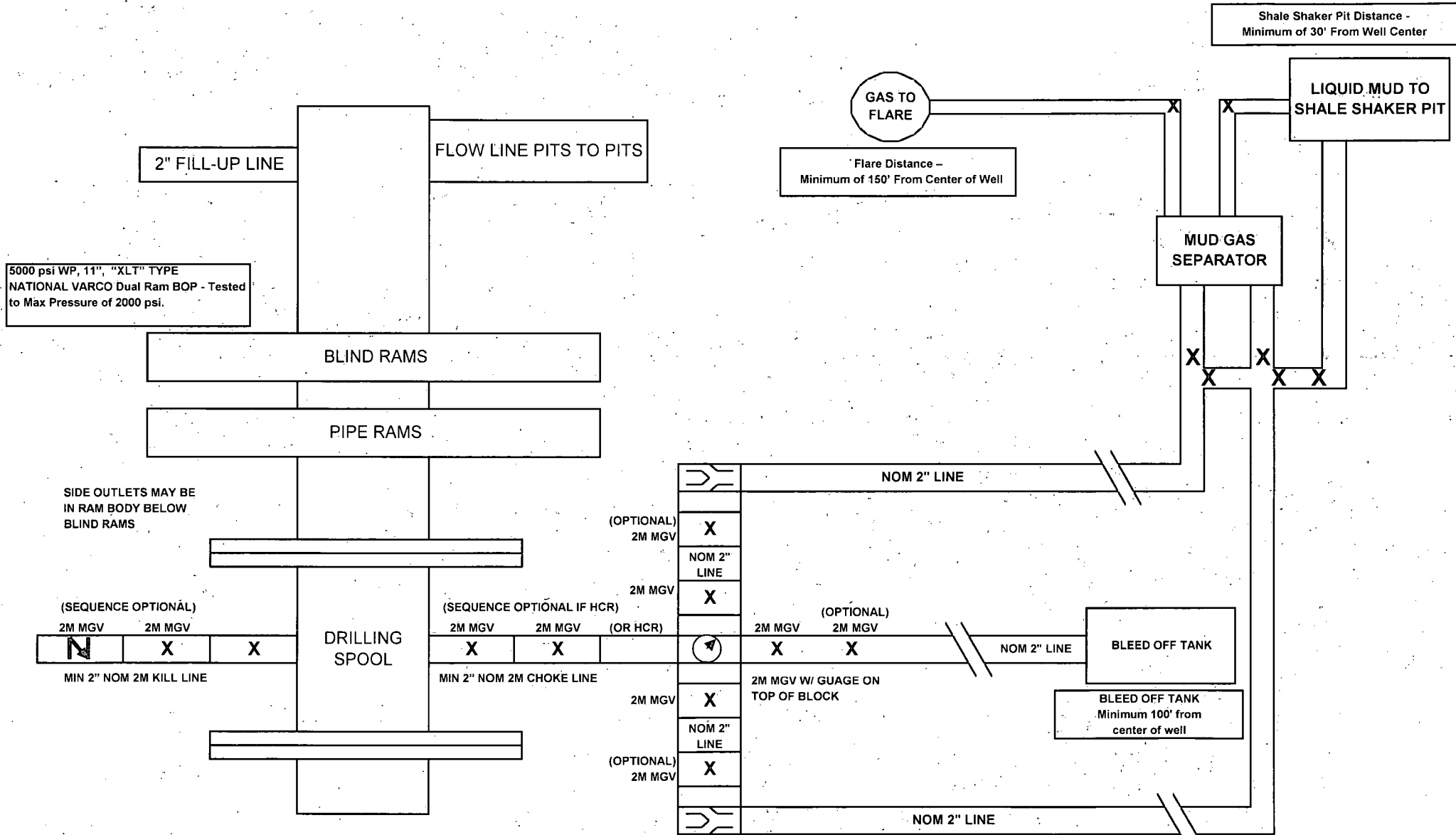

MGV = Manual Gate Valve
 CKV = Check Valve
 HCR = Hydraulically Controlled Remote Valve

NOTE: All lines, valves and chokes are shown at the minimum size allowed, but may be larger

Lime Rock Resources II-A, L.P.

Kaiser 7 K #4

Unit K, S7-T18S-R27E, Eddy County, NM

Design: Closed Loop System with roll-off steel bins (pits)

CRI/HOBBS will supply (2) bins (100 bbl) volume, rails and transportation relating to the Close Loop System. Specification of the Closed Loop System is attached.

Contacts: Gary Wallace (432) 638-4076 Cell (575) 393-1079 Office

Scomi Oil Tool: Supervisor – Armando Soto (432) 553-7979 Hobbs, NM

Monitoring 24 Hour service.

Equipment:

Centrifuges – Derrick Brand

Rig Shakers – Brandt Brand

D-watering Unit

Air pumps on location for immediate remediation process

Layout of Close Loop System with bins, centrifuges and shakers attached.

Cuttings and associated liquids will be hauled to a State regulated third party disposal site (CRI or Controlled Recovery, Inc.). The disposal site permit is DFP = #R9166.

2- (250 bbl) tanks to hold fluid

2-CRI bins with track system

2-500 bbl frac tanks with fresh water

2-500 bbl frac tanks for brine water

Operations:

Closed Loop System equipment will be inspected daily by each tour and any necessary maintenance performed. leak in system will be repaired and/or contained immediately. OCD will be notified within 48 hours of any spill. Remediation process will start immediately.

Closure:

During drilling operations all liquids, drilling fluids and cuttings will be hauled off via CRI equipment to DFP #R9166.

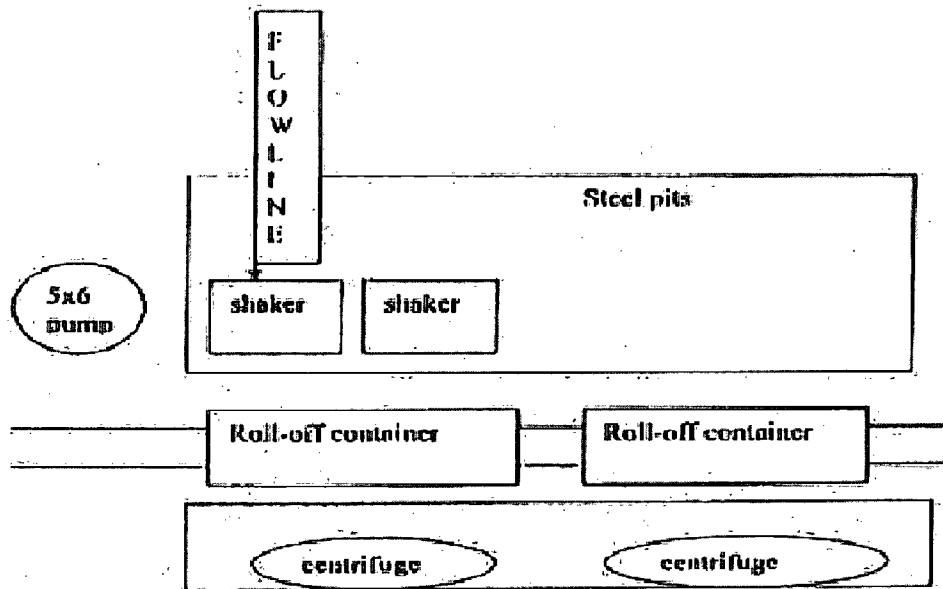

This will be maintained by 24 hour solids control personnel that stay on location.

TOMMY WILSON
CLS
 CLOSED LOOP
 SPECIALTY

Office: 973.746.1689

Cell: 973.748.6367

Permit Conditions of Approval

API: 30-015-43301

OCD Reviewer	Condition
	Once the well is spud, to prevent ground water contamination through whole or partial conduits from the surface, the operator shall drill without interruption through the fresh water zone or zones and shall immediately set in cement the water protection string