

UNITED STATES
DEPARTMENT OF THE INTERIOR
BUREAU OF LAND MANAGEMENT

NMOCD
Artesia

FORM APPROVED
OMB NO. 1004-0137
Expires: January 31, 2018.

SUNDRY NOTICES AND REPORTS ON WELLS
Do not use this form for proposals to drill or to re-enter an abandoned well. Use form 3160-3 (APD) for such proposals.

- 5. Lease Serial No.
NMLC061634B
- 6. If Indian, Allottee or Tribe Name
- 7. If Unit or CA/Agreement, Name and/or No.
891000303X

SUBMIT IN TRIPLICATE - Other instructions on page 2

- 8. Well Name and No.
POKER LAKE UNIT 29 BS 122H
- 9. API Well No.
30-015-45916-00-X1

1. Type of Well
 Oil Well Gas Well Other

2. Name of Operator
 XTO PERMIAN OPERATING LLC
 Contact: KELLY KARDOS
 E-Mail: kelly_kardos@xtoenergy.com

3a. Address
 6401 HOLIDAY HILL ROAD BLDG 5
 MIDLAND, TX 79707

3b. Phone No. (include area code)
 Ph: 432-620-4374

- 10. Field and Pool or Exploratory Area
POWER
- 11. County or Parish, State
EDDY COUNTY, NM

4. Location of Well (Footage, Sec., T., R., M., or Survey Description)
 Sec 29 T25S R31E SWNW 2310FNL 690FWL
 32.102200 N Lat, 103.806656 W Lon

12. CHECK THE APPROPRIATE BOX(ES) TO INDICATE NATURE OF NOTICE, REPORT, OR OTHER DATA

TYPE OF SUBMISSION	TYPE OF ACTION			
<input checked="" type="checkbox"/> Notice of Intent	<input type="checkbox"/> Acidize	<input type="checkbox"/> Deepen	<input type="checkbox"/> Production (Start/Resume)	<input type="checkbox"/> Water Shut-Off
<input type="checkbox"/> Subsequent Report	<input type="checkbox"/> Alter Casing	<input type="checkbox"/> Hydraulic Fracturing	<input type="checkbox"/> Reclamation	<input type="checkbox"/> Well Integrity
<input type="checkbox"/> Final Abandonment Notice	<input type="checkbox"/> Casing Repair	<input type="checkbox"/> New Construction	<input type="checkbox"/> Recomplete	<input checked="" type="checkbox"/> Other Change to Original A PD
	<input type="checkbox"/> Change Plans	<input type="checkbox"/> Plug and Abandon	<input type="checkbox"/> Temporarily Abandon	
	<input type="checkbox"/> Convert to Injection	<input type="checkbox"/> Plug Back	<input type="checkbox"/> Water Disposal	

13. Describe Proposed or Completed Operation: Clearly state all pertinent details, including estimated starting date of any proposed work and approximate duration thereof. If the proposal is to deepen directionally or recomplete horizontally, give subsurface locations and measured and true vertical depths of all pertinent markers and zones. Attach the Bond under which the work will be performed or provide the Bond No. on file with BLM/BIA. Required subsequent reports must be filed within 30 days following completion of the involved operations. If the operation results in a multiple completion or recompletion in a new interval, a Form 3160-4 must be filed once testing has been completed. Final Abandonment Notices must be filed only after all requirements, including reclamation, have been completed and the operator has determined that the site is ready for final inspection.

XTO Permian Operation, LLC requests permission to make the following changes to the original APD:

Change the BHL from 200' FSL & 990' FWL in Sec. 5-T26S-R31E to 200' FSL & 990' FWL in Sec. 32-T25S-R31E.

Change the casing/cement program per the attached procedure.

XTO requests to not utilize centralizers in the curve and lateral

XTO requests a variance to be able to batch drill this well if necessary. In doing so, XTO will set 7" casing and ensure that the well is cemented properly and the well is static. With floats holding, no pressure on the csg annulus, and the installation of a 10K TA cap as per GE

SEE ATTACHED FOR
CONDITIONS OF APPROVAL
RECEIVED
DEC 28 2019

14. I hereby certify that the foregoing is true and correct.

Electronic Submission #493144 verified by the BLM Well Information System
 For XTO PERMIAN OPERATING LLC, sent to the Carlsbad
 Committed to AFMSS for processing by PRISCILLA PEREZ on 11/20/2019 (20PP0478SE)

Name (Printed/Typed) KELLY KARDOS Title REGULATORY COORDINATOR

Signature (Electronic Submission) Date 11/20/2019

APPROVED

THIS SPACE FOR FEDERAL OR STATE OFFICE USE
 DEF 11 2019

Approved By _____ Title _____ Date _____

Office BUREAU OF LAND MANAGEMENT
 ROSWELL FIELD OFFICE

Title 18 U.S.C. Section 1001 and Title 43 U.S.C. Section 1212, make it a crime for any person knowingly and willfully to make to any department or agency of the United States any false, fictitious or fraudulent statements or representations as to any matter within its jurisdiction.

11/27/20 K4

Additional data for EC transaction #493144 that would not fit on the form

32. Additional remarks, continued

recommendations, XTO will contact the BLM to skid the rig to drill the remaining wells on the pad. Once surface and both intermediate strings are all completed, XTO will begin drilling the production hole on each of the wells.

Poker Lake Unit 29 BS 701H ? 30-015-45918
Poker Lake Unit 29 BS 901H ? 30-015-45936
Poker Lake Unit 29 BS 121H ? 30-015-45935
Poker Lake Unit 29 BS 122H ? 30-015-45916
Poker Lake Unit 29 BS 102H ? 30-015-46715

District I
1625 N. French Dr., Hobbs, NM 88240
Phone: (575) 393-6161 Fax: (575) 393-0720
District II
811 S. First St., Artesia, NM 88210
Phone: (575) 748-1283 Fax: (575) 748-9720
District III
1000 Rio Brazos Road, Aztec, NM 87410
Phone: (505) 334-6178 Fax: (505) 334-6170
District IV
1220 S. St. Francis Dr., Santa Fe, NM 87505
Phone: (505) 476-3460 Fax: (505) 476-3462

State of New Mexico
Energy, Minerals & Natural Resources Department
OIL CONSERVATION DIVISION
1220 South St. Francis Dr.
Santa Fe, NM 87505

Form C-102
Revised August 1, 2011
Submit one copy to appropriate
District Office
 AMENDED REPORT

WELL LOCATION AND ACREAGE DEDICATION PLAT

¹ API Number 30-015-45916		² Pool Code 98220		³ Pool Name PURPLE SAGE WOLFCAMP					
⁴ Property Code		⁵ Property Name POKER LAKE UNIT 29 BS			⁶ Well Number 122H				
⁷ OGRID No. 373075		⁸ Operator Name XTO PERMIAN OPERATING, LLC.			⁹ Elevation 3,364'				
¹⁰ Surface Location									
UL or lot no. E	Section 29	Township 25 S	Range 31 E	Lot Idn	Feet from the 2,310	North/South line NORTH	Feet from the 690	East/West line WEST	County EDDY
¹¹ Bottom Hole Location If Different From Surface									
UL or lot no. M	Section 32	Township 25 S	Range 31 E	Lot Idn	Feet from the 200	North/South line SOUTH	Feet from the 990	East/West line WEST	County EDDY
¹² Dedicated Acres 480	¹³ Joint or Infill	¹⁴ Consolidation Code	¹⁵ Order No.						

No allowable will be assigned to this completion until all interests have been consolidated or a non-standard unit has been approved by the division.

	<p>16</p> <p>GEODETIC COORDINATES NAD 83 NME SURFACE LOCATION Y = 401,315.6 X = 704,420.7 LAT. = 32.102201°N LONG. = 103.806656°W</p> <p>FIRST TAKE POINT NAD 83 NME Y = 400,628.0 X = 704,718.3 LAT. = 32.100307°N LONG. = 103.805706°W</p> <p>CORNER COORDINATES TABLE NAD 83 NME A - Y = 400,966.5 N, X = 703,729.5 E B - Y = 400,975.3 N, X = 705,056.4 E C - Y = 398,308.0 N, X = 703,719.7 E D - Y = 398,321.1 N, X = 705,044.2 E E - Y = 395,652.0 N, X = 703,732.0 E F - Y = 395,661.7 N, X = 705,058.7 E G - Y = 392,996.2 N, X = 703,742.0 E H - Y = 393,006.1 N, X = 705,072.1 E</p> <p>CORNER COORDINATES TABLE NAD 27 NME A - Y = 400,908.6 N, X = 662,544.0 E B - Y = 400,917.4 N, X = 663,870.9 E C - Y = 398,250.2 N, X = 662,534.1 E D - Y = 398,263.3 N, X = 663,858.6 E E - Y = 395,594.2 N, X = 662,546.3 E F - Y = 395,603.9 N, X = 663,873.0 E G - Y = 392,938.5 N, X = 662,556.2 E H - Y = 392,948.4 N, X = 663,886.3 E</p> <p>GEODETIC COORDINATES NAD 27 NME SURFACE LOCATION Y = 401,257.7 X = 663,235.2 LAT. = 32.102076°N LONG. = 103.806178°W</p> <p>FIRST TAKE POINT NAD 27 NME Y = 400,570.1 X = 663,532.8 LAT. = 32.100182°N LONG. = 103.805227°W</p>	<p>17 OPERATOR CERTIFICATION</p> <p>I hereby certify that the information contained herein is true and complete to the best of my knowledge and belief, and that this organization either owns a working interest or unleased mineral interest in the land including the proposed bottom hole location or has a right to drill this well at this location pursuant to a contract with an owner of such a mineral or working interest, or to a voluntary pooling agreement or a compulsory pooling order heretofore entered by the division.</p> <p>Kelly Kardos 11/20/19</p> <p>Signature Date</p> <p>Kelly Kardos Printed Name</p> <p>kelly_kardos@xtoenergy.com E-mail Address</p>
	<p>GEODETIC COORDINATES NAD 83 NME SURFACE LOCATION Y = 401,315.6 X = 704,420.7 LAT. = 32.102201°N LONG. = 103.806656°W</p> <p>FIRST TAKE POINT NAD 83 NME Y = 400,628.0 X = 704,718.3 LAT. = 32.100307°N LONG. = 103.805706°W</p> <p>CORNER COORDINATES TABLE NAD 83 NME A - Y = 400,966.5 N, X = 703,729.5 E B - Y = 400,975.3 N, X = 705,056.4 E C - Y = 398,308.0 N, X = 703,719.7 E D - Y = 398,321.1 N, X = 705,044.2 E E - Y = 395,652.0 N, X = 703,732.0 E F - Y = 395,661.7 N, X = 705,058.7 E G - Y = 392,996.2 N, X = 703,742.0 E H - Y = 393,006.1 N, X = 705,072.1 E</p> <p>CORNER COORDINATES TABLE NAD 27 NME A - Y = 400,908.6 N, X = 662,544.0 E B - Y = 400,917.4 N, X = 663,870.9 E C - Y = 398,250.2 N, X = 662,534.1 E D - Y = 398,263.3 N, X = 663,858.6 E E - Y = 395,594.2 N, X = 662,546.3 E F - Y = 395,603.9 N, X = 663,873.0 E G - Y = 392,938.5 N, X = 662,556.2 E H - Y = 392,948.4 N, X = 663,886.3 E</p> <p>GEODETIC COORDINATES NAD 27 NME SURFACE LOCATION Y = 401,257.7 X = 663,235.2 LAT. = 32.102076°N LONG. = 103.806178°W</p> <p>FIRST TAKE POINT NAD 27 NME Y = 400,570.1 X = 663,532.8 LAT. = 32.100182°N LONG. = 103.805227°W</p>	<p>18 SURVEYOR CERTIFICATION</p> <p>I hereby certify that the well location shown on this plat was plotted from field notes of actual surveys made by me or under my supervision, and that the same is true and correct to the best of my belief.</p> <p>07-08-2019 Date of Survey</p> <p>Signature and Seal of Professional Surveyor:</p> <p>MARK DILLON HARP 23786 Certificate Number</p> <p>RR 2017071005</p>

Intent As Drilled

API #
30-015-45916

Operator Name: XTO PERMIAN OPERATING, LLC	Property Name: POKER LAKE UNIT 29 BS	Well Number 122H
--	---	---------------------

Kick Off Point (KOP)

UL	Section	Township	Range	Lot	Feet	From N/S	Feet	From E/W	County
E	29	25S	31E		2310	NORTH	690	WEST	EDDY
Latitude					Longitude			NAD	
32.102201					-103.806656			83	

First Take Point (FTP)

UL	Section	Township	Range	Lot	Feet	From N/S	Feet	From E/W	County
L	29	25S	31E		2310	SOUTH	990	WEST	EDDY
Latitude					Longitude			NAD	
32.100307					-103.805706			83	

Last Take Point (LTP)

UL	Section	Township	Range	Lot	Feet	From N/S	Feet	From E/W	County
M	32	25S	31E		330	SOUTH	990	WEST	EDDY
Latitude					Longitude			NAD	
32.080255					-103.805781			83	

Is this well the defining well for the Horizontal Spacing Unit? N

Is this well an infill well? Y

If infill is yes please provide API if available, Operator Name and well number for Defining well for Horizontal Spacing Unit.

API #
30-015-45918

Operator Name: XTO PERMIAN OPERATING, LLC	Property Name: POKER LAKE UNIT 29 BS	Well Number 701H
--	---	---------------------

DRILLING PLAN: BLM COMPLIANCE
(Supplement to BLM 3160-3)

XTO Energy Inc.
Poker Lake Unit 25 Brushy Draw 122H
Projected TD: 20309' MD / 12534' TVD
SHL: 2310' FNL & 690' FWL , Section 29, T25S, R31E
BHL: 200' FSL & 990' FWL , Section 32, T25S, R31E
Eddy County, NM

1. Geologic Name of Surface Formation
A. Quaternary

2. Estimated Tops of Geological Markers & Depths of Anticipated Fresh Water, Oil or Gas

Formation	Well Depth (TVD)	Water/Oil/Gas
Rustler	811'	Water
Top of Salt	1174'	Water
Base of Salt	3910'	Water
Delaware	4124'	Water
Bone Spring	8066'	Water
1st Bone Spring Ss	9063'	Water/Oil/Gas
2nd Bone Spring Ss	9924'	Water/Oil/Gas
3rd Bone Spring Ss	11018'	Water/Oil/Gas
Wolfcamp Shale	11429'	Water/Oil/Gas
Wolfcamp A	11587'	Water/Oil/Gas
Wolfcamp B	12025'	Water/Oil/Gas
Wolfcamp D	12418'	Water/Oil/Gas
Target/Land Curve	12534'	Water/Oil/Gas

*** Hydrocarbons @ Brushy Canyon
*** Groundwater depth 40' (per NM State Engineers Office).

No other formations are expected to yield oil, gas or fresh water in measurable volumes. The surface fresh water sands will be protected by setting 13 3/8" inch casing @ 1050' (124' above the salt) and circulating cement back to surface. The salt will be isolated by setting 9-5/8" inch casing at 4050' and circulating cement to surface. The second intermediate will isolate from the salt down to the next casing seat by setting 7-0" inch casing at 11925'. A 6-0" inch curve and lateral hole will be drilled to MD/TD and a 4-1/2 inch liner will be set at TD and cemented.

3. Casing Design

Hole Size	Depth	OD Csg	Weight	Collar	Grade	New/Used	SF Burst	SF Collapse	SF Tension
17-1/2"	0' - 1050'	13 3/8"	54.5	STC	J-55	New	2.17	2.38	8.98
12-1/4"	0' - 4050'	9-5/8"	40	STC	J-55	New	1.21	2.02	2.79
8-3/4"	0' - 11925'	7-0"	32	BTC	P-110	New	1.31	1.83	2.35
6-0"	11,600' - 20309'	4-1/2"	13.5	BTC	P-110	New	1.31	1.21	2.02

- XTO requests to not utilize centralizers in the curve and lateral
- 9-5/8" Collapse analyzed using 50% evacuation based on regional experience.
- 4-1/2" Tension calculated using vertical hanging weight plus the lateral weight multiplied by a friction factor of 0.35
- Test on Casing will be limited to 70% burst of the casing or 1500 psi, whichever is less

Wellhead:

Permanent Wellhead - GE RSH Multibowl System

- A. Starting Head: 13-5/8" 10M top flange x 13-3/8" SOW bottom
- B. Tubing Head: 13-5/8" 10M bottom flange x 7-1/16" 15M top flange
- Wellhead will be installed by manufacturer's representatives.
 - Manufacturer will monitor welding process to ensure appropriate temperature of seal.
 - Operator will test the 7-0" casing per BLM Onshore Order 2
 - Wellhead Manufacturer representative will not be present for BOP test plug installation

4. Cement Program

Surface Casing: 13 3/8", 54.5 New J-55, STC casing to be set at +/- 1050'

Lead: 550 sxs EconoCem-HLTRRC (mixed at 12.9 ppg, 1.87 ft³/sx, 10.13 gal/sx water)
Tail: 300 sxs Halcem-C + 2% CaCl (mixed at 14.8 ppg, 1.35 ft³/sx, 6.39 gal/sx water)
Compressives: 12-hr = 900 psi 24 hr = 1500 psi
TOC @ Surface

1st Intermediate Casing: 9-5/8", 40 New J-55, STC casing to be set at +/- 4050'

Lead: 1080 sxs EconoCem-HLTRRC (mixed at 12.9 ppg, 1.87 ft³/sx, 10.13 gal/sx water)
Tail: 370 sxs Halcem-C + 2% CaCl (mixed at 14.8 ppg, 1.35 ft³/sx, 6.39 gal/sx water)
Compressives: 12-hr = 900 psi 24 hr = 1500 psi
TOC @ Surface

2nd Intermediate Casing: 7-0", 32 New P-110, BTC casing to be set at +/- 11925'

Lead: 1130 sxs Halcem-C + 2% CaCl (mixed at 12.9 ppg, 1.88 ft³/sx, 9.61 gal/sx water)
Tail: 220 sxs Halcem-C + 2% CaCl (mixed at 14.8 ppg, 1.33 ft³/sx, 6.39 gal/sx water)
Compressives: 12-hr = 900 psi 24 hr = 1500 psi
TOC @ 3800'

Production Liner: 4-1/2", 13.5 New P-110, BTC casing to be set at +/- 20309'

Tail: 610 sxs VersaCem (mixed at 13.2 ppg, 1.61 ft³/sx, 8.38 gal/sx water)
Compressives: 12-hr = 1375 psi 24 hr = 2285 psi

5. Pressure Control Equipment

Once the permanent WH is installed on the 13-3/8 casing, the blow out preventer equipment (BOP) will consist of a 13-5/8" minimum 5M Hydril and a 13-5/8" minimum 10M 3-Ram BOP. MASP should not exceed 6041 psi. In any instance where 10M BOP is required by BLM, XTO requests a variance to utilize 5M annular with 10M ram preventers (a common BOP configuration, which allows use of 10M rams in unlikely event that pressures exceed 5M). Also a variance is requested to test the 5M annular to 70% of working pressure at 3500 psi.

All BOP testing will be done by an independent service company. Annular pressure tests will be limited to 50% of the working pressure. When nipping up on the 13 3/8", 10M bradenhead and flange, the BOP test will be limited to 10000 psi. When nipping up on the 7-0", the BOP will be tested to a minimum of 10000 psi. All BOP tests will include a low pressure test as per BLM regulations. The 10M BOP diagrams are attached. Blind rams will be functioned tested each trip, pipe rams will be functioned tested each day.

A variance is requested to allow use of a flex hose as the choke line from the BOP to the Choke Manifold. If this hose is used, a copy of the manufacturer's certification and pressure test chart will be kept on the rig. Attached is an example of a certification and pressure test chart. The manufacturer does not require anchors.

XTO requests a variance to be able to batch drill this well if necessary. In doing so, XTO will set 7" casing and ensure that the well is cemented properly and the well is static. With floats holding, no pressure on the csg annulus, and the installation of a 10K TA cap as per GE recommendations, XTO will contact the BLM to skid the rig to drill the remaining wells on the pad. Once surface and both intermediate strings are all completed, XTO will begin drilling the production hole on each of the wells.

6. Proposed Mud Circulation System

INTERVAL	Hole Size	Mud Type	MW (ppg)	Viscosity (sec/qt)	Fluid Loss (cc)
0' - 1050'	17-1/2"	FW/Native	8.4-8.8	35-40	NC
1050' - 4050'	12-1/4"	Brine	9.8-10.2	30-32	NC
4050' to 11925'	8-3/4"	FW / Cut Brine	8.7-10.0	32-36	NC
11925' to 20309'	6-0"	Cut Brine / Polymer / OBM	13 - 13.5	32-50	NC - 20

The necessary mud products for weight addition and fluid loss control will be on location at all times. Spud with fresh water/native mud. Drill out from under 13-3/8" surface casing with brine solution. A 9.8-10.2 ppg brine mud will be used while drilling through the salt formation. Use fibrous materials as needed to control seepage and lost circulation. Pump viscous sweeps as needed for hole cleaning. Pump speed will be recorded on a daily drilling report after mudding up. A Pason or Totco will be used to detect changes in loss or gain of mud volume. A mud test will be performed every 24 hours to determine: density, viscosity, strength, filtration and pH as necessary. Use available solids controls equipment to help keep mud weight down after mud up. Rig up solids control equipment to operate as a closed loop system.

7. Auxiliary Well Control and Monitoring Equipment

- A. A Kelly cock will be in the drill string at all times.
- B. A full opening drill pipe stabbing valve having appropriate connections will be on the rig floor at all times.
- C. H2S monitors will be on location when drilling below the 9-5/8" casing.

8. Logging, Coring and Testing Program

Mud Logger: Mud Logging Unit (2 man) below intermediate casing.

Open hole logging will not be done on this well.

9. Abnormal Pressures and Temperatures / Potential Hazards

None Anticipated. BHT of 160 to 180 F is anticipated. No H2S is expected but monitors will be in place to detect any H2S occurrences. Should these circumstances be encountered the operator and drilling contractor are prepared to take all necessary steps to ensure safety of all personnel and environment. Lost circulation could occur but is not expected to be a serious problem in this area and hole seepage will be compensated for by additions of small amounts of LCM in the drilling fluid. The maximum anticipated bottom hole pressure for this well is 8799 psi.

10. Anticipated Starting Date and Duration of Operations

Road and location construction will begin after Santa Fe and BLM have approved the APD. Anticipated spud date will be as soon after Santa Fe and BLM approval and as soon as a rig will be available. Move in operations and drilling is expected to take 45 days. If production casing is run, an additional 30 days will be needed to complete well and construct surface facilities and/or lay flow lines in order to place well on production.

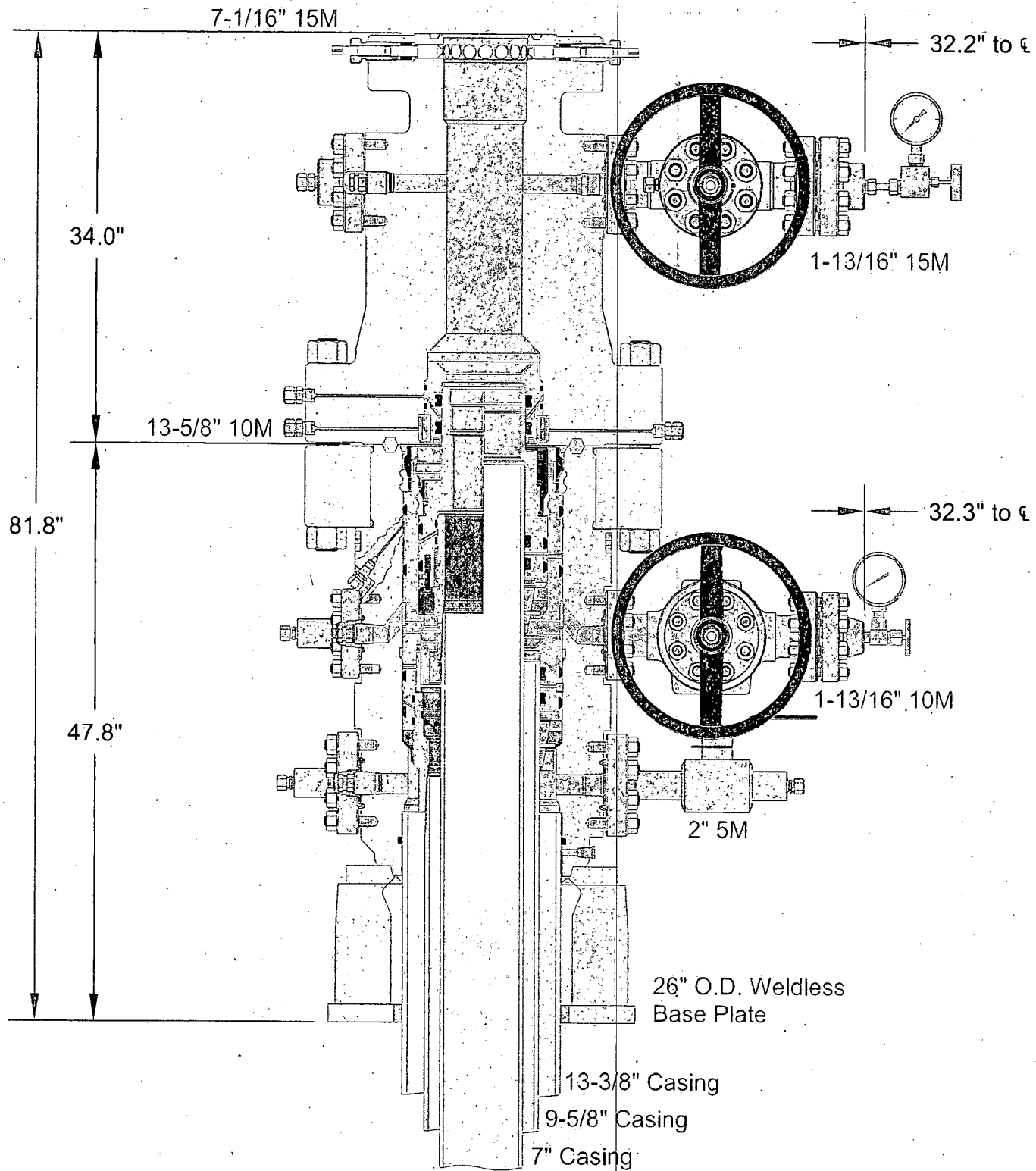

Pressure Control

13-3/8" x 9-5/8" x 7" 15M RSH-2 Wellhead
 Assembly, With T-EBS-F-HP Tubing Head



COPYRIGHT & PROPRIETARY NOTICE

Copyright 2017 Baker Hughes, a GE company, LLC (unpublished work). All rights reserved. The information contained in this document is company confidential and proprietary property of Baker Hughes and its affiliates. It is to be used only for the benefit of Baker Hughes and may not be distributed, transmitted, reproduced, altered or used for any purpose without the express written consent of Baker Hughes.

ALL DIMENSIONS ARE APPROXIMATE, NOT FOR MANUFACTURING USE.

DRAWN BY:	VJK	DRAWING NO.	HP180197
REVIEWED BY:		Rev.	NC Sht. 1 of 1
APPROVED BY:		DATE:	31OCT18

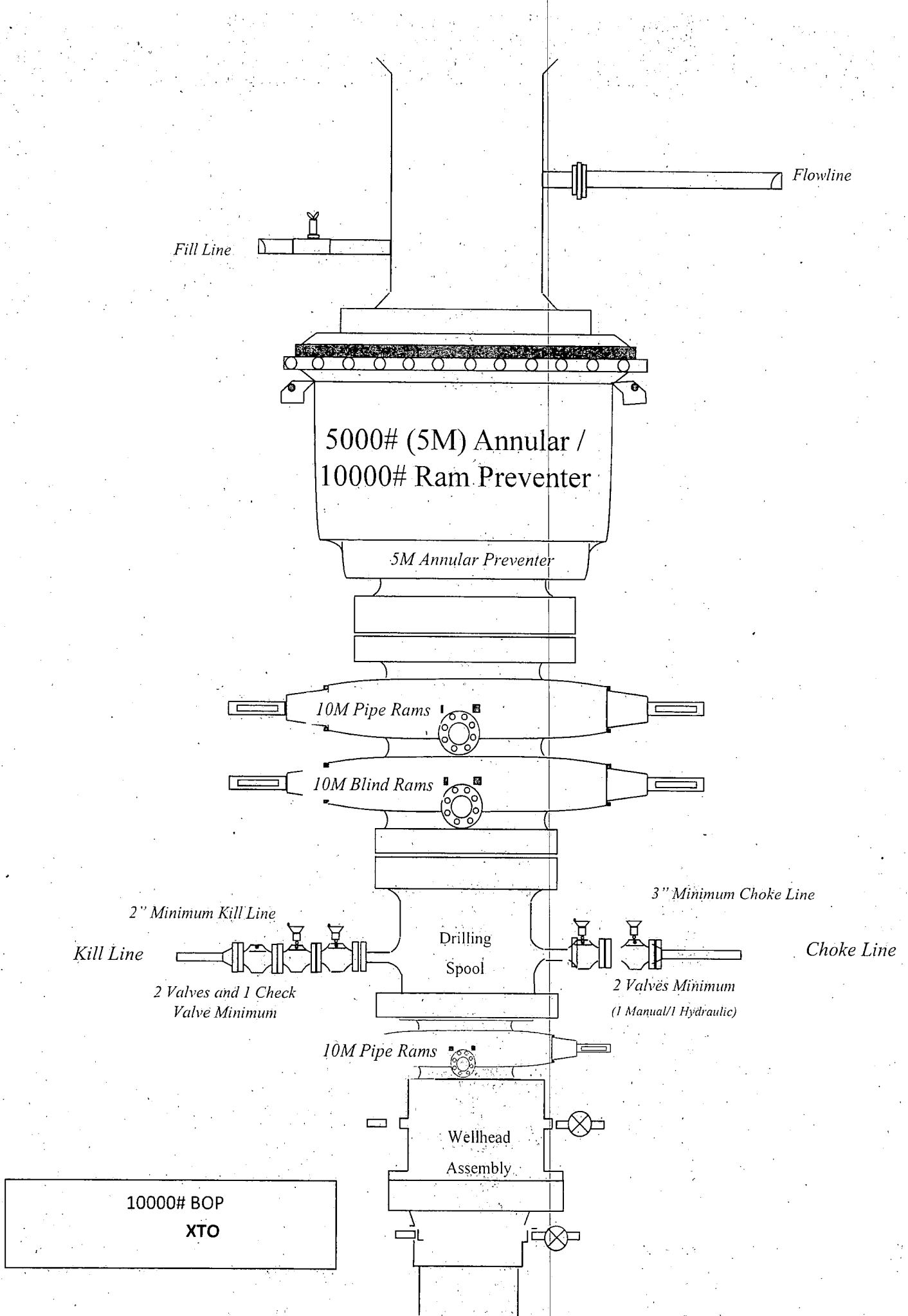

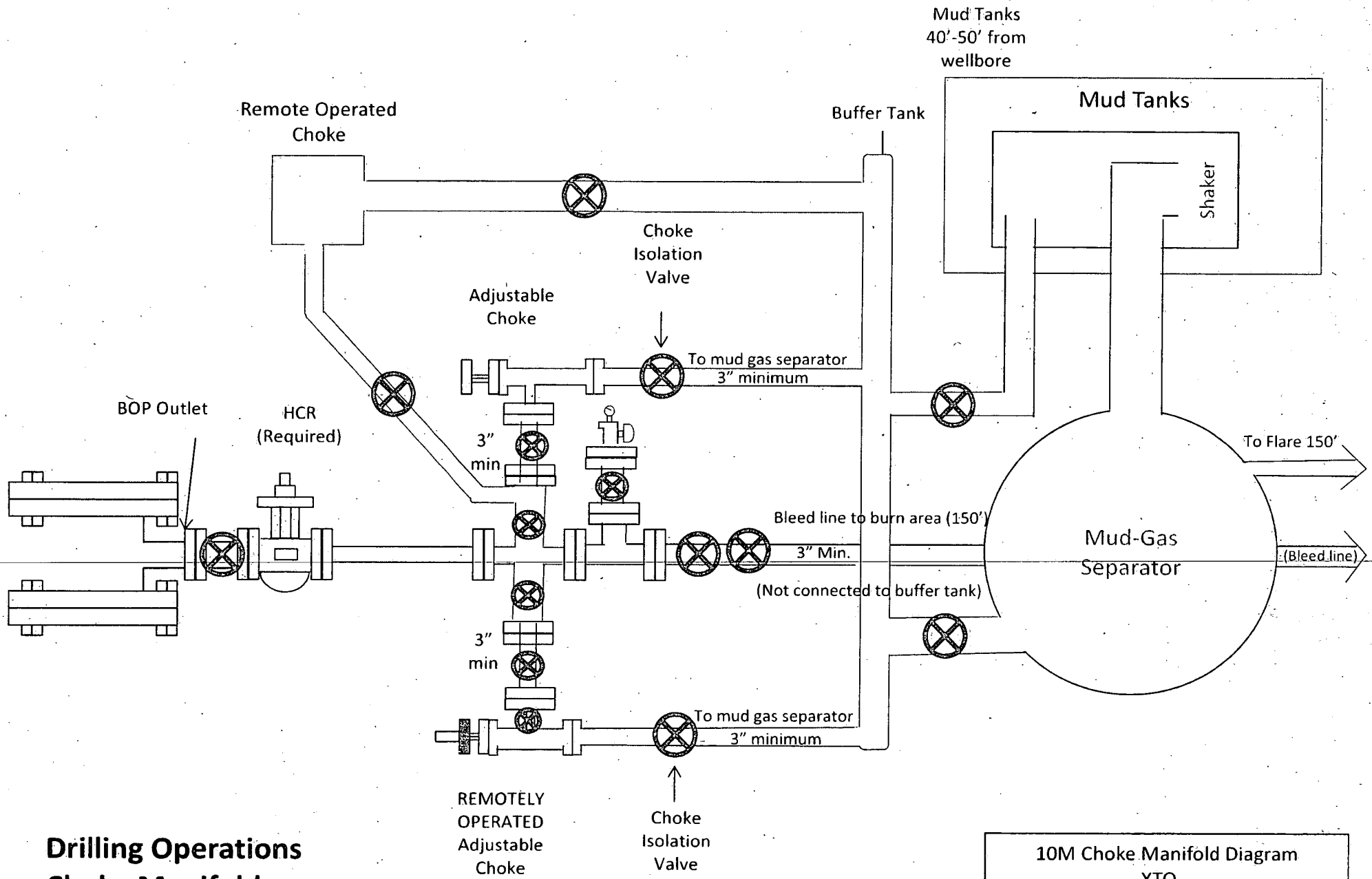

**Drilling Operations
Choke Manifold
10M Service**

10M Choke Manifold Diagram
XTO

10,000 PSI Annular BOP Variance Request

XTO Energy/XTO Permian Op. request a variance to use a 5000 psi annular BOP with a 10,000 psi BOP stack. The component and compatibility tables along with the general well control plans demonstrate how the 5000 psi annular BOP will be protected from pressures that exceed its rated working pressure (RWP). The pressure at which the control of the wellbore is transferred from the annular preventer to another available preventer will not exceed 3500 psi (70% of the RWP of the 5000 psi annular BOPL).

1. Component and Preventer Compatibility Tables

The tables below outline the tubulars and the compatible preventers in use. This table, combined with the drilling fluid, documents that two barriers to flow will be maintained at all times.

8-1/2" Production Hole Section 10M psi Requirement					
Component	OD	Primary Preventer	RWP	Alternate Preventer(s)	RWP
Drillpipe	5.000" or 4.500"	Annular	5M	Upper 3.5"-5.5" VBR Lower 3.5"-5.5" VBR	10M 10M
HWDP	5.000" or 4.500"	Annular	5M	Upper 3.5"-5.5" VBR Lower 3.5"-5.5" VBR	10M 10M
Jars	6.500"	Annular	5M	-	-
DCs and MWD tools	6.500"-8.000"	Annular	5M	-	-
Mud Motor	6.750"-8.000"	Annular	5M	-	-
Production Casing	5-1/2"	Annular	5M	-	-
Open-Hole	-	Blind Rams	10M	-	-

2. Well Control Procedures

Below are the minimal high-level tasks prescribed to assure a proper shut-in while drilling, tripping, running casing, pipe out of the hole (open hole), and moving the BHA through the BOPs. At least one well control drill will be performed weekly per crew to demonstrate compliance with the procedure and well control plan. The well control drill will be recorded in the daily drilling log. The type of drill will be determined by the ongoing operations, but reasonable attempts will be made to vary the type of drill conducted (pit, trip, open hole, choke, etc.). This well control plan will be available for review by rig personnel in the XTO Energy/Permian Operating drilling supervisor's office on location and on the rig floor. All BOP equipment will be tested as per Onshore O&G Order No. 2 with the exception of the 5000 psi annular which will be tested to 70% of its RWP.

General Procedure While Drilling

1. Sound alarm (alert crew)
2. Space out drill string
3. Shut down pumps (stop pumps and rotary)
4. Shut-in well (uppermost applicable BOP, typically annular preventer, first. HCR & choke will already be in the closed position.)
5. Confirm shut-in
6. Notify toolpusher/company representative
7. Read and record the following:
 - a. SIDPP & SICP
 - b. Pit gain
 - c. Time
8. Regroup and identify forward plan

9. If pressure has built or is anticipated during the kill to reach 70% or greater of the RWP of the annular preventer, confirm spacing and close the upper variable bore rams.

General Procedure While Tripping

1. Sound alarm (alert crew)
2. Stab full-opening safety valve & close
3. Space out drill string
4. Shut-in well (uppermost applicable BOP, typically annular preventer, first. HCR & choke will already be in the closed position.)
5. Confirm shut-in
6. Notify toolpusher/company representative
7. Read and record the following:
 - a. SIDPP & SICP
 - b. Pit gain
 - c. Time
8. Regroup and identify forward plan
9. If pressure has built or is anticipated during the kill to reach 70% of the RWP of the annular preventer, confirm spacing and close the upper variable bore rams.

General Procedure While Running Production Casing

1. Sound alarm (alert crew)
2. Stab crossover and full-opening safety valve and close
3. Space out string
4. Shut-in well (uppermost applicable BOP, typically annular preventer, first. HCR & choke will already be in the closed position.)
5. Confirm shut-in
6. Notify toolpusher/company representative
7. Read and record the following:
 - a. SIDPP & SICP
 - b. Pit gain
 - c. Time
8. Regroup and identify forward plan
9. If pressure has built or is anticipated during the kill to reach 70% or greater of the RWP of the annular preventer, confirm spacing and close the upper variable bore rams.

General Procedure With No Pipe In Hole (Open Hole)

1. Sound alarm (alert crew)
2. Shut-in with blind rams (HCR & choke will already be in the closed position)
3. Confirm shut-in
4. Notify toolpusher/company representative
5. Read and record the following:
 - a. SICP
 - b. Pit gain
 - c. Time
6. Regroup and identify forward plan

General Procedures While Pulling BHA Through Stack

1. PRIOR to pulling last joint of drillpipe through stack:
 - a. Perform flow check. If flowing, continue to (b).
 - b. Sound alarm (alert crew)
 - c. Stab full-opening safety valve and close
 - d. Space out drill string with tool joint just beneath the upper variable bore rams
 - e. Shut-in using upper variable bore rams (HCR & choke will already be in the closed position)
 - f. Confirm shut-in
 - g. Notify toolpusher/company representative
 - h. Read and record the following:
 - i. SIDPP & SICP
 - ii. Pit gain
 - iii. Time
 - i. Regroup and identify forward plan
2. With BHA in the stack and compatible ram preventer and pipe combination immediately available:
 - a. Sound alarm (alert crew)
 - b. Stab crossover and full-opening safety valve and close
 - c. Space out drill string with upset just beneath the upper variable bore rams
 - d. Shut-in using upper variable bore rams (HCR & choke will already be in the closed position)
 - e. Confirm shut-in
 - f. Notify toolpusher/company representative
 - g. Read and record the following:
 - i. SIDPP & SICP

- ii. Pit gain
 - iii. Time
- h. Regroup and identify forward plan
- 3. With BHA in the stack and NO compatible ram preventer and pipe combination immediately available:
 - a. Sound alarm (alert crew)
 - b. If possible, pull string clear of the stack and follow "Open Hole" procedure.
 - c. If impossible to pull string clear of the stack:
 - d. Stab crossover, make up one joint/stand of drillpipe and full-opening safety valve and close
 - e. Space out drill string with tooljoint just beneath the upper variable bore ram
 - f. Shut-in using upper variable bore ram (HCR & choke will already be in the closed position)
 - g. Confirm shut-in
 - h. Notify toolpusher/company representative
 - i. Read and record the following:
 - i. SIDPP & SICP
 - ii. Pit gain
 - iii. Time
 - j. Regroup and identify forward plan

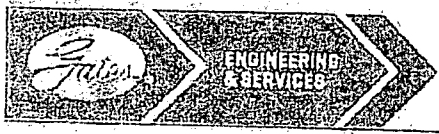

GATES E & S NORTH AMERICA, INC
 DU-TEX
 134 44TH STREET
 CORPUS CHRISTI, TEXAS 78405

PHONE: 361-887-9807
 FAX: 361-887-0812
 EMAIL: crpe@s@gates.com
 WEB: www.gates.com

GRADE D PRESSURE TEST CERTIFICATE

Customer :	AUSTIN DISTRIBUTING	Test Date:	6/8/2014
Customer Ref. :	PENDING	Hose Serial No.:	D-060814-1
Invoice No. :	201709	Created By:	NORMA

Product Description:	FD3.0:210R41716.5KFLGE/E LE		
End Fitting 1 :	4 1/16 in.SK FLG	End Fitting 2 :	4 1/16 in.SK FLG
Gates Part No. :	4774-6001	Assembly Code :	L33090011513D-060814-1
Working Pressure :	5,000 PSI	Test Pressure :	7,500 PSI

Gates E & S North America, Inc. certifies that the following hose assembly has been tested to the Gates Oilfield Roughneck Agreement/Specification requirements and passed the 15 minute hydrostatic test per API Spec 7K/Q1, Fifth Edition, June 2010, Test pressure 9.6.7 and per Table 9 to 7,500 psi in accordance with this product number. Hose burst pressure 9.6.7.2 exceeds the minimum of 2.5 times the working pressure per Table 9.

Quality:	QUALITY	Technical Supervisor:	PRODUCTION
Date:	6/8/2014	Date:	6/8/2014
Signature:	<i>[Signature]</i>	Signature:	<i>[Signature]</i>

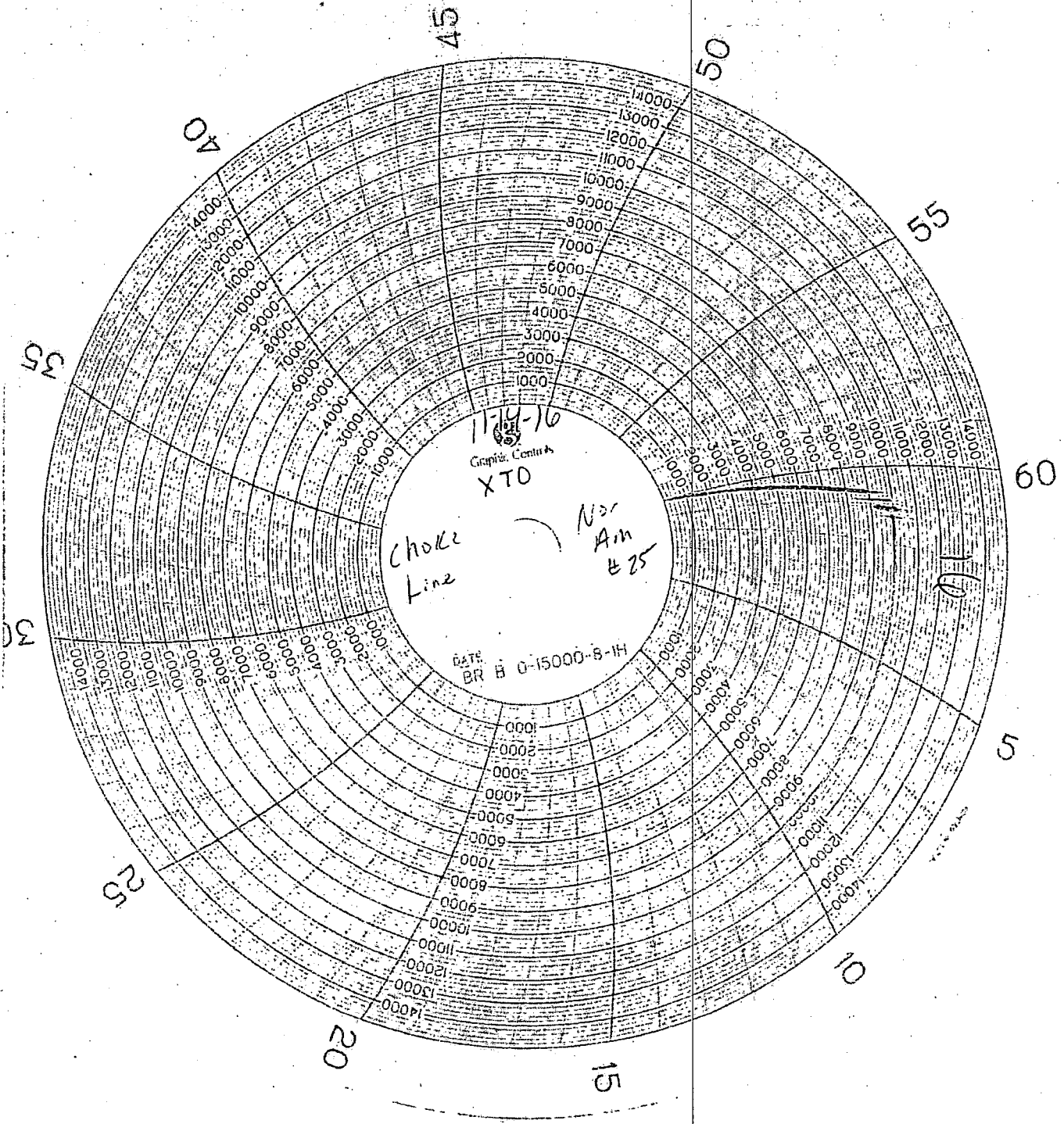

NOON

HOSE I.D. 2 1/2" LENGTH 42ft END 1 4 1/16" 8XFLY END 2 4 1/16" 8XFLY

GRADE D WORKING PRESSURE 5,000 P.S.I.

TEST PRESSURE 7,500 P.S.I. ASSEMBLY DATE 6-8-14

TEST DATE 6-8-14 SERIAL # L3309601151 3D-0408-1K

NAME D. J. CR # 25013

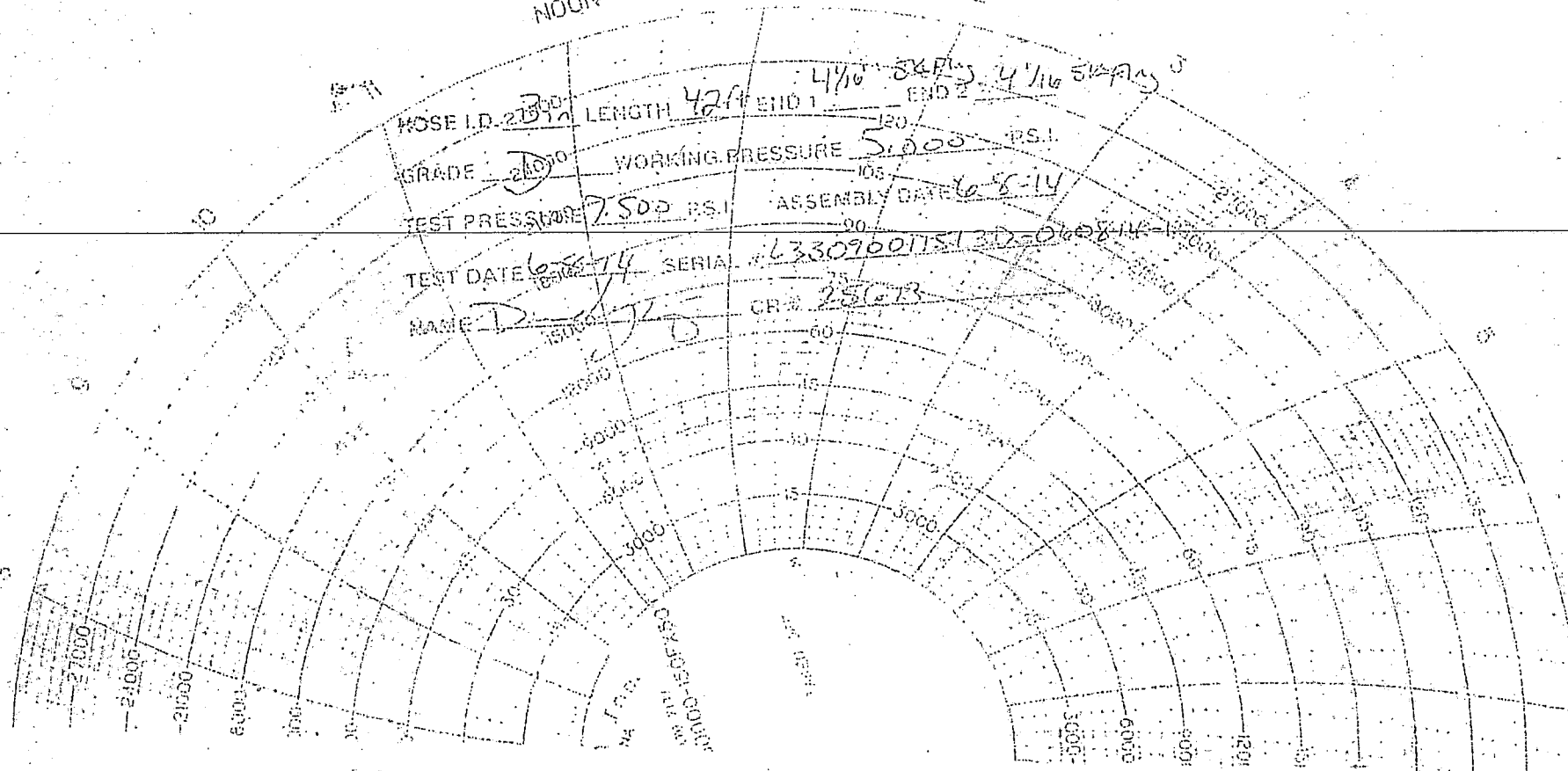

XTO Enerav

Project: Eddy County, NM (NAD27) NMEZ Grid
 Site: PLU 29 BS
 Well: 122H
 Wellbore: 122H Lateral
 Design: Plan #1

3364+25 @ 3389.00ustf (T E101)
 NAD 1927 (NADCON CONUS)

To convert a Magnetic Direction to a True Direction, Add 6.79° East
 To convert a Magnetic Direction to a Grid Direction, Add 6.51°
 Magnetic North is 6.79° East of True North (Magnetic Declination)
 Magnetic North is 6.51° East of Grid North (Magnetic Convergence)

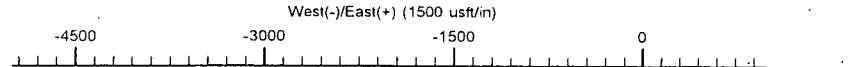

SECTION DETAILS

MD	Inc	Azi	TVD	+N/-S	+E/-W	Dleg	TFace	VSect
0.00	0.00	0.00	0.00	0.00	0.00	0.00	0.00	0.00
7870.00	0.00	0.00	7870.00	0.00	0.00	0.00	0.00	0.00
8203.28	5.00	104.75	8202.85	-3.70	14.05	1.50	104.75	3.72
11432.05	5.00	104.75	11419.34	-75.35	286.13	0.00	0.00	75.80
11682.00	0.00	0.00	11668.98	-78.13	296.67	2.00	180.00	78.60
11882.00	0.00	0.00	11868.98	-78.13	296.67	0.00	0.00	78.60
12382.00	40.00	179.90	12329.34	-245.69	296.96	8.00	179.90	246.15
12885.00	90.30	179.90	12534.00	-687.60	297.73	10.00	0.00	688.06
20179.31	90.30	179.90	12495.81	-7981.80	310.46	0.00	0.00	7982.28
20309.31	90.30	179.90	12495.13	-8111.80	310.69	0.00	0.00	8112.28

TARGET DETAILS

Name	TVD	+N/-S	+E/-W	Northing	Easting	Shape
PLU29 BS 122H SHL	0.00	0.00	0.00	401257.70	663235.20	Point
PLU29 BS 122H LTP_330FSL_340FEL	12495.00	-7981.80	309.70	393275.90	663544.90	Point
PLU29 BS 122H PBHL_200FSL_340FEL	12495.13	-8111.80	310.20	393145.90	663545.40	Point
PLU29 BS 122H FTP_345FNL_336FEL	12534.00	-687.60	297.60	400570.10	663532.80	Point
PLU29 BS 122H LP	12534.00	-687.60	297.73	400570.10	663532.93	Point

FORMATION TOP DETAILS

TVDPATH	MDPATH	Formation
811.00	811.00	Rustler
1174.00	1174.00	Salado
3910.00	3910.00	Base of Salt
4124.00	4124.00	Delaware
5114.00	5114.00	Cherry Canyon
6800.00	6800.00	Brushy Canyon
7851.00	7851.00	Basal Brushy Canyon
8066.00	8066.09	Bone Spring
8093.00	8093.13	Bone Spring Lime
9063.00	9066.71	1st Bone Sand
9475.00	9480.28	2nd Bone Lime
9924.00	9930.99	2nd Bone Sand
10146.00	10153.84	3rd Bone Lime
11018.00	11029.17	3rd Bone Sand
11340.00	11352.40	Red Hills
11429.00	11441.74	Wolfcamp
11458.00	11470.83	Wolfcamp X
11553.00	11565.99	Wolfcamp Y
11587.00	11600.01	Wolfcamp A
12025.00	12039.28	Wolfcamp B
12418.00	12510.95	Wolfcamp D
12534.00	12878.79	LP

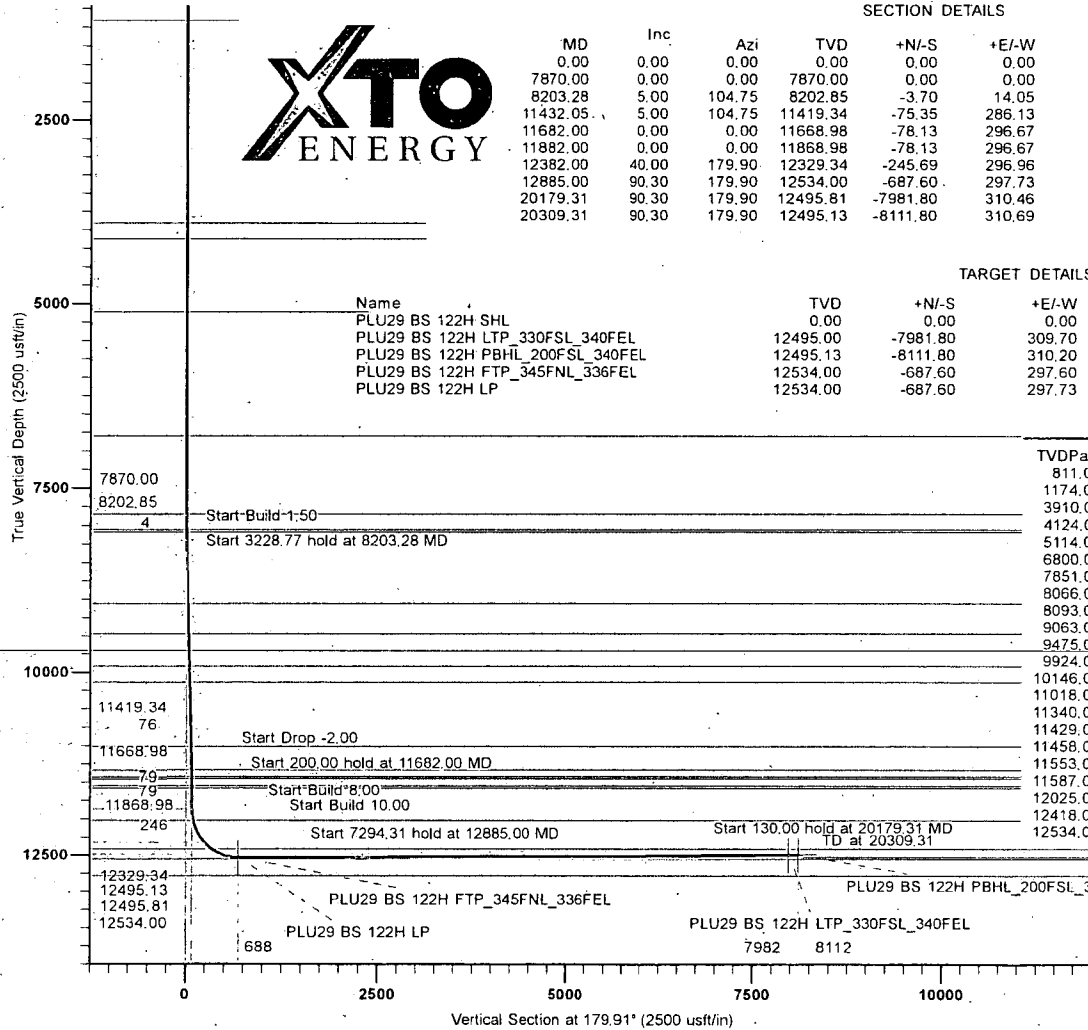

Azimuths to Grid North
 True North: -0.28°
 Magnetic North: 6.51°

Magnetic Field
 Strength: 47596.2nT
 Dip Angle: 59.88°
 Date: 11/07/2019
 Model: IGRF2015

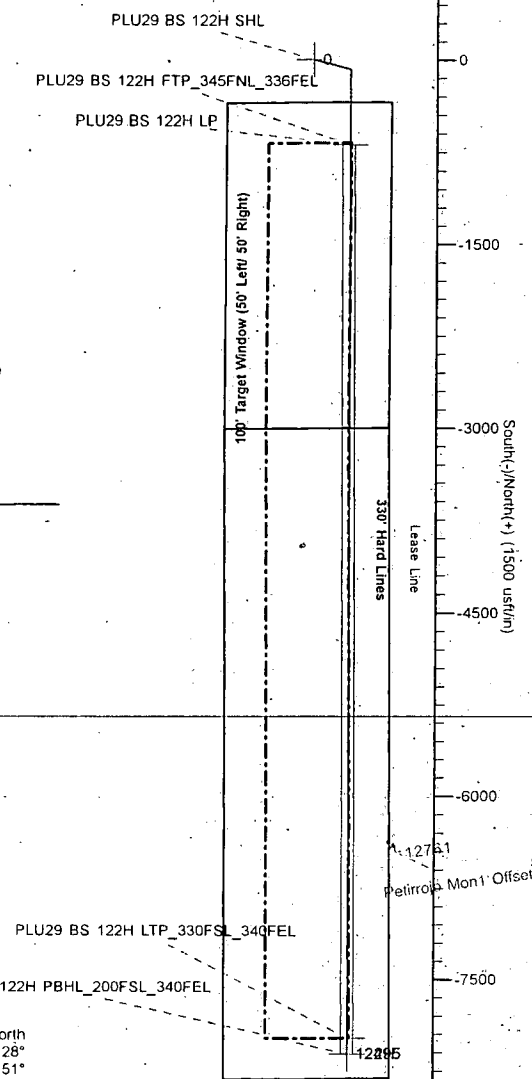

Planning Report

Database:	STRYKER_EDM	Local Co-ordinate Reference:	Well 122H - Slot PLU29 BS 122H SHL
Company:	XTO Energy	TVD Reference:	3364+25 @ 3389.00usft (T E101)
Project:	Eddy County, NM (NAD27) NMEZ Grid	MD Reference:	3364+25 @ 3389.00usft (T E101)
Site:	PLU 29 BS	North Reference:	Grid
Well:	122H	Survey Calculation Method:	Minimum Curvature
Wellbore:	122H Lateral		
Design:	Plan #1		

Project:	Eddy County, NM (NAD27) NMEZ Grid		
Map System:	US State Plane 1927 (Exact solution)	System Datum:	Mean Sea Level
Geo Datum:	NAD 1927 (NADCON CONUS)		
Map Zone:	New Mexico East 3001		

Site:	PLU 29 BS		
Site Position:	Map	Northing:	401,257.20 usft
From:		Easting:	663,145.30 usft
Position Uncertainty:	0.00 usft	Slot Radius:	13.20 in
		Latitude:	32° 6' 7.47468126 N
		Longitude:	103° 48' 23.28438096 W
		Grid Convergence:	0.28 °

Well:	122H - Slot PLU29 BS 122H SHL			
Well Position:	+N-S	0.50 usft	Northing:	401,257.70 usft
	+E-W	89.90 usft	Easting:	663,235.20 usft
Position Uncertainty:	0.00 usft		Wellhead Elevation:	
			Latitude:	32° 6' 7.47528042 N
			Longitude:	103° 48' 22.23921945 W
			Ground Level:	3,364.00 usft

Wellbore:	122H Lateral				
Magnetics:	Model Name	Sample Date	Declination (°)	Dip Angle (°)	Field Strength (nT)
	IGRF2015	11/07/19	6.79	59.88	47,596.16748860

Design:	Plan #1			
Audit Notes:				
Version:	Phase:	PROTOTYPE	Tie On Depth:	0.00
Vertical Section:	Depth From (TVD) (usft)	+N-S (usft)	+E-W (usft)	Direction (°)
	0.00	0.00	0.00	179.91

Plan Survey Tool Program	Date	11/07/19		
Depth From (usft)	Depth To (usft)	Survey (Wellbore)	Tool Name	Remarks
1	0.00	20,309.32 Plan #1 (122H Lateral)	MWD+IFR1+MS OWSG MWD + IFR1 + Multi-St	

Planning Report

Database:	STRYKER_EDM	Local Co-ordinate Reference:	Well 122H - Slot PLU29 BS 122H SHL
Company:	XTO Energy	TVD Reference:	3364+25 @ 3389.00usft (T E101)
Project:	Eddy County, NM (NAD27) NMEZ Grid	MD Reference:	3364+25 @ 3389.00usft (T E101)
Site:	PLU 29 BS	North Reference:	Grid
Well:	122H	Survey Calculation Method:	Minimum Curvature
Wellbore:	122H Lateral		
Design:	Plan #1		

Plan Sections										
Measured Depth (usft)	Inclination (°)	Azimuth (°)	Vertical Depth (usft)	+N/-S (usft)	+E/-W (usft)	Dogleg Rate (°/100ft)	Build Rate (°/100ft)	Turn Rate (°/100ft)	TFO (°)	Target
0.00	0.00	0.00	0.00	0.00	0.00	0.00	0.00	0.00	0.00	
7,870.00	0.00	0.00	7,870.00	0.00	0.00	0.00	0.00	0.00	0.00	
8,203.28	5.00	104.75	8,202.85	-3.70	14.05	1.50	1.50	0.00	104.75	
11,432.05	5.00	104.75	11,419.34	-75.35	286.13	0.00	0.00	0.00	0.00	
11,682.00	0.00	0.00	11,668.98	-78.13	296.67	2.00	-2.00	0.00	180.00	
11,862.00	0.00	0.00	11,868.98	-78.13	296.67	0.00	0.00	0.00	0.00	
12,382.00	40.00	179.90	12,329.34	-245.69	296.96	8.00	8.00	0.00	179.90	
12,885.00	90.30	179.90	12,534.00	-687.60	297.73	10.00	10.00	0.00	0.00	
20,179.31	90.30	179.90	12,495.81	-7,981.80	310.46	0.00	0.00	0.00	0.00	PLU29 BS 122H LTP
20,309.32	90.30	179.90	12,495.13	-8,111.80	310.69	0.00	0.00	0.00	0.00	PLU29 BS 122H PBH

Planning Report

Database:	STRYKER_EDM	Local Co-ordinate Reference:	Well-122H - Slot PLU29 BS 122H SHL
Company:	XTO Energy	TVD Reference:	3364+25 @ 3389.00usft (T E101)
Project:	Eddy County, NM (NAD27) NMEZ Grid	MD Reference:	3364+25 @ 3389.00usft (T E101)
Site:	PLU 29 BS	North Reference:	Grid
Well:	122H	Survey Calculation Method:	Minimum Curvature
Wellbore:	122H Lateral		
Design:	Plan #1		

Planned Survey										
Measured Depth (usft)	Inclination (°)	Azimuth (°)	Vertical Depth (usft)	+N/-S (usft)	+E/-W (usft)	Vertical Section (usft)	Dogleg Rate (°/100ft)	Build Rate (°/100ft)	Turn Rate (°/100ft)	
0.00	0.00	0.00	0.00	0.00	0.00	0.00	0.00	0.00	0.00	0.00
100.00	0.00	0.00	100.00	0.00	0.00	0.00	0.00	0.00	0.00	0.00
200.00	0.00	0.00	200.00	0.00	0.00	0.00	0.00	0.00	0.00	0.00
300.00	0.00	0.00	300.00	0.00	0.00	0.00	0.00	0.00	0.00	0.00
400.00	0.00	0.00	400.00	0.00	0.00	0.00	0.00	0.00	0.00	0.00
500.00	0.00	0.00	500.00	0.00	0.00	0.00	0.00	0.00	0.00	0.00
600.00	0.00	0.00	600.00	0.00	0.00	0.00	0.00	0.00	0.00	0.00
700.00	0.00	0.00	700.00	0.00	0.00	0.00	0.00	0.00	0.00	0.00
800.00	0.00	0.00	800.00	0.00	0.00	0.00	0.00	0.00	0.00	0.00
811.00	0.00	0.00	811.00	0.00	0.00	0.00	0.00	0.00	0.00	0.00
Rüstler										
900.00	0.00	0.00	900.00	0.00	0.00	0.00	0.00	0.00	0.00	0.00
1,000.00	0.00	0.00	1,000.00	0.00	0.00	0.00	0.00	0.00	0.00	0.00
1,100.00	0.00	0.00	1,100.00	0.00	0.00	0.00	0.00	0.00	0.00	0.00
1,174.00	0.00	0.00	1,174.00	0.00	0.00	0.00	0.00	0.00	0.00	0.00
Salado										
1,200.00	0.00	0.00	1,200.00	0.00	0.00	0.00	0.00	0.00	0.00	0.00
1,300.00	0.00	0.00	1,300.00	0.00	0.00	0.00	0.00	0.00	0.00	0.00
1,400.00	0.00	0.00	1,400.00	0.00	0.00	0.00	0.00	0.00	0.00	0.00
1,500.00	0.00	0.00	1,500.00	0.00	0.00	0.00	0.00	0.00	0.00	0.00
1,600.00	0.00	0.00	1,600.00	0.00	0.00	0.00	0.00	0.00	0.00	0.00
1,700.00	0.00	0.00	1,700.00	0.00	0.00	0.00	0.00	0.00	0.00	0.00
1,800.00	0.00	0.00	1,800.00	0.00	0.00	0.00	0.00	0.00	0.00	0.00
1,900.00	0.00	0.00	1,900.00	0.00	0.00	0.00	0.00	0.00	0.00	0.00
2,000.00	0.00	0.00	2,000.00	0.00	0.00	0.00	0.00	0.00	0.00	0.00
2,100.00	0.00	0.00	2,100.00	0.00	0.00	0.00	0.00	0.00	0.00	0.00
2,200.00	0.00	0.00	2,200.00	0.00	0.00	0.00	0.00	0.00	0.00	0.00
2,300.00	0.00	0.00	2,300.00	0.00	0.00	0.00	0.00	0.00	0.00	0.00
2,400.00	0.00	0.00	2,400.00	0.00	0.00	0.00	0.00	0.00	0.00	0.00
2,500.00	0.00	0.00	2,500.00	0.00	0.00	0.00	0.00	0.00	0.00	0.00
2,600.00	0.00	0.00	2,600.00	0.00	0.00	0.00	0.00	0.00	0.00	0.00
2,700.00	0.00	0.00	2,700.00	0.00	0.00	0.00	0.00	0.00	0.00	0.00
2,800.00	0.00	0.00	2,800.00	0.00	0.00	0.00	0.00	0.00	0.00	0.00
2,900.00	0.00	0.00	2,900.00	0.00	0.00	0.00	0.00	0.00	0.00	0.00
3,000.00	0.00	0.00	3,000.00	0.00	0.00	0.00	0.00	0.00	0.00	0.00
3,100.00	0.00	0.00	3,100.00	0.00	0.00	0.00	0.00	0.00	0.00	0.00
3,200.00	0.00	0.00	3,200.00	0.00	0.00	0.00	0.00	0.00	0.00	0.00
3,300.00	0.00	0.00	3,300.00	0.00	0.00	0.00	0.00	0.00	0.00	0.00
3,400.00	0.00	0.00	3,400.00	0.00	0.00	0.00	0.00	0.00	0.00	0.00
3,500.00	0.00	0.00	3,500.00	0.00	0.00	0.00	0.00	0.00	0.00	0.00
3,600.00	0.00	0.00	3,600.00	0.00	0.00	0.00	0.00	0.00	0.00	0.00
3,700.00	0.00	0.00	3,700.00	0.00	0.00	0.00	0.00	0.00	0.00	0.00
3,800.00	0.00	0.00	3,800.00	0.00	0.00	0.00	0.00	0.00	0.00	0.00
3,900.00	0.00	0.00	3,900.00	0.00	0.00	0.00	0.00	0.00	0.00	0.00
3,910.00	0.00	0.00	3,910.00	0.00	0.00	0.00	0.00	0.00	0.00	0.00
Base of Salt										
4,000.00	0.00	0.00	4,000.00	0.00	0.00	0.00	0.00	0.00	0.00	0.00
4,100.00	0.00	0.00	4,100.00	0.00	0.00	0.00	0.00	0.00	0.00	0.00
4,124.00	0.00	0.00	4,124.00	0.00	0.00	0.00	0.00	0.00	0.00	0.00
Delaware										
4,200.00	0.00	0.00	4,200.00	0.00	0.00	0.00	0.00	0.00	0.00	0.00
4,300.00	0.00	0.00	4,300.00	0.00	0.00	0.00	0.00	0.00	0.00	0.00
4,400.00	0.00	0.00	4,400.00	0.00	0.00	0.00	0.00	0.00	0.00	0.00
4,500.00	0.00	0.00	4,500.00	0.00	0.00	0.00	0.00	0.00	0.00	0.00

Planning Report

Database:	STRYKER_EDM	Local Co-ordinate Reference:	Well 122H - Slot PLU29 BS 122H SHL
Company:	XTO Energy	TVD Reference:	3364+25 @ 3389.00usft (T-E101)
Project:	Eddy County, NM (NAD27) NMEZ Grid	MD Reference:	3364+25 @ 3389.00usft (T-E101)
Site:	PLU 29 BS	North Reference:	Grid
Well:	122H	Survey Calculation Method:	Minimum Curvature
Wellbore:	122H Lateral		
Design:	Plan #1		

Planned Survey									
Measured Depth (usft)	Inclination (°)	Azimuth (°)	Vertical Depth (usft)	+N/-S (usft)	+E/-W (usft)	Vertical Section (usft)	Dogleg Rate (°/100ft)	Build Rate (°/100ft)	Turn Rate (°/100ft)
4,600.00	0.00	0.00	4,600.00	0.00	0.00	0.00	0.00	0.00	0.00
4,700.00	0.00	0.00	4,700.00	0.00	0.00	0.00	0.00	0.00	0.00
4,800.00	0.00	0.00	4,800.00	0.00	0.00	0.00	0.00	0.00	0.00
4,900.00	0.00	0.00	4,900.00	0.00	0.00	0.00	0.00	0.00	0.00
5,000.00	0.00	0.00	5,000.00	0.00	0.00	0.00	0.00	0.00	0.00
5,100.00	0.00	0.00	5,100.00	0.00	0.00	0.00	0.00	0.00	0.00
5,114.00	0.00	0.00	5,114.00	0.00	0.00	0.00	0.00	0.00	0.00
Cherry Canyon									
5,200.00	0.00	0.00	5,200.00	0.00	0.00	0.00	0.00	0.00	0.00
5,300.00	0.00	0.00	5,300.00	0.00	0.00	0.00	0.00	0.00	0.00
5,400.00	0.00	0.00	5,400.00	0.00	0.00	0.00	0.00	0.00	0.00
5,500.00	0.00	0.00	5,500.00	0.00	0.00	0.00	0.00	0.00	0.00
5,600.00	0.00	0.00	5,600.00	0.00	0.00	0.00	0.00	0.00	0.00
5,700.00	0.00	0.00	5,700.00	0.00	0.00	0.00	0.00	0.00	0.00
5,800.00	0.00	0.00	5,800.00	0.00	0.00	0.00	0.00	0.00	0.00
5,900.00	0.00	0.00	5,900.00	0.00	0.00	0.00	0.00	0.00	0.00
6,000.00	0.00	0.00	6,000.00	0.00	0.00	0.00	0.00	0.00	0.00
6,100.00	0.00	0.00	6,100.00	0.00	0.00	0.00	0.00	0.00	0.00
6,200.00	0.00	0.00	6,200.00	0.00	0.00	0.00	0.00	0.00	0.00
6,300.00	0.00	0.00	6,300.00	0.00	0.00	0.00	0.00	0.00	0.00
6,400.00	0.00	0.00	6,400.00	0.00	0.00	0.00	0.00	0.00	0.00
6,500.00	0.00	0.00	6,500.00	0.00	0.00	0.00	0.00	0.00	0.00
6,600.00	0.00	0.00	6,600.00	0.00	0.00	0.00	0.00	0.00	0.00
6,700.00	0.00	0.00	6,700.00	0.00	0.00	0.00	0.00	0.00	0.00
6,800.00	0.00	0.00	6,800.00	0.00	0.00	0.00	0.00	0.00	0.00
Brushy Canyon									
6,900.00	0.00	0.00	6,900.00	0.00	0.00	0.00	0.00	0.00	0.00
7,000.00	0.00	0.00	7,000.00	0.00	0.00	0.00	0.00	0.00	0.00
7,100.00	0.00	0.00	7,100.00	0.00	0.00	0.00	0.00	0.00	0.00
7,200.00	0.00	0.00	7,200.00	0.00	0.00	0.00	0.00	0.00	0.00
7,300.00	0.00	0.00	7,300.00	0.00	0.00	0.00	0.00	0.00	0.00
7,400.00	0.00	0.00	7,400.00	0.00	0.00	0.00	0.00	0.00	0.00
7,500.00	0.00	0.00	7,500.00	0.00	0.00	0.00	0.00	0.00	0.00
7,600.00	0.00	0.00	7,600.00	0.00	0.00	0.00	0.00	0.00	0.00
7,700.00	0.00	0.00	7,700.00	0.00	0.00	0.00	0.00	0.00	0.00
7,800.00	0.00	0.00	7,800.00	0.00	0.00	0.00	0.00	0.00	0.00
7,851.00	0.00	0.00	7,851.00	0.00	0.00	0.00	0.00	0.00	0.00
Basal Brushy Canyon									
7,870.00	0.00	0.00	7,870.00	0.00	0.00	0.00	0.00	0.00	0.00
7,900.00	0.45	104.75	7,900.00	-0.03	0.11	0.03	1.50	1.50	0.00
8,000.00	1.95	104.75	7,999.98	-0.56	2.14	0.57	1.50	1.50	0.00
8,066.09	2.94	104.75	8,066.00	-1.28	4.87	1.29	1.50	1.50	0.00
Bone Spring									
8,093.13	3.35	104.75	8,093.00	-1.66	6.30	1.67	1.50	1.50	0.00
Bone Spring Lime									
8,100.00	3.45	104.75	8,099.86	-1.76	6.69	1.77	1.50	1.50	0.00
8,203.28	5.00	104.75	8,202.85	-3.70	14.05	3.72	1.50	1.50	0.00
8,300.00	5.00	104.75	8,299.21	-5.85	22.20	5.88	0.00	0.00	0.00
8,400.00	5.00	104.75	8,398.83	-8.07	30.63	8.11	0.00	0.00	0.00
8,500.00	5.00	104.75	8,498.45	-10.29	39.06	10.35	0.00	0.00	0.00
8,600.00	5.00	104.75	8,598.07	-12.50	47.48	12.58	0.00	0.00	0.00
8,700.00	5.00	104.75	8,697.69	-14.72	55.91	14.81	0.00	0.00	0.00
8,800.00	5.00	104.75	8,797.31	-16.94	64.34	17.04	0.00	0.00	0.00

Planning Report

Database:	STRYKER_EDM	Local Co-ordinate Reference:	Well 122H - Slot PLU29 BS 122H SHL
Company:	XTO Energy	TVD Reference:	3364+25 @ 3389.00usft (T E101)
Project:	Eddy County, NM (NAD27) NMEZ Grid	MD Reference:	3364+25 @ 3389.00usft (T E101)
Site:	PLU 29 BS	North Reference:	Grid
Well:	122H	Survey Calculation Method:	Minimum Curvature
Wellbore:	122H Lateral		
Design:	Plan #1		

Planned Survey										
Measured Depth (usft)	Inclination (°)	Azimuth (°)	Vertical Depth (usft)	+N/-S (usft)	+E/-W (usft)	Vertical Section (usft)	Dogleg Rate (°/100ft)	Build Rate (°/100ft)	Turn Rate (°/100ft)	
8,900.00	5.00	104.75	8,896.93	-19.16	72.76	19.28	0.00	0.00	0.00	
9,000.00	5.00	104.75	8,996.55	-21.38	81.19	21.51	0.00	0.00	0.00	
9,066.71	5.00	104.75	9,063.00	-22.86	86.81	23.00	0.00	0.00	0.00	
1st Bone Sand										
9,100.00	5.00	104.75	9,096.17	-23.60	89.62	23.74	0.00	0.00	0.00	
9,200.00	5.00	104.75	9,195.79	-25.82	98.04	25.97	0.00	0.00	0.00	
9,300.00	5.00	104.75	9,295.41	-28.04	106.47	28.21	0.00	0.00	0.00	
9,400.00	5.00	104.75	9,395.03	-30.26	114.90	30.44	0.00	0.00	0.00	
9,480.28	5.00	104.75	9,475.00	-32.04	121.66	32.23	0.00	0.00	0.00	
2nd Bone Lime										
9,500.00	5.00	104.75	9,494.64	-32.48	123.32	32.67	0.00	0.00	0.00	
9,600.00	5.00	104.75	9,594.26	-34.70	131.75	34.90	0.00	0.00	0.00	
9,700.00	5.00	104.75	9,693.88	-36.92	140.18	37.14	0.00	0.00	0.00	
9,800.00	5.00	104.75	9,793.50	-39.14	148.60	39.37	0.00	0.00	0.00	
9,900.00	5.00	104.75	9,893.12	-41.35	157.03	41.60	0.00	0.00	0.00	
9,931.00	5.00	104.75	9,924.00	-42.04	159.64	42.29	0.00	0.00	0.00	
2nd Bone Sand										
10,000.00	5.00	104.75	9,992.74	-43.57	165.46	43.83	0.00	0.00	0.00	
10,100.00	5.00	104.75	10,092.36	-45.79	173.88	46.07	0.00	0.00	0.00	
10,153.84	5.00	104.75	10,146.00	-46.99	178.42	47.27	0.00	0.00	0.00	
3rd Bone Lime										
10,200.00	5.00	104.75	10,191.98	-48.01	182.31	48.30	0.00	0.00	0.00	
10,300.00	5.00	104.75	10,291.60	-50.23	190.74	50.53	0.00	0.00	0.00	
10,400.00	5.00	104.75	10,391.22	-52.45	199.16	52.76	0.00	0.00	0.00	
10,500.00	5.00	104.75	10,490.84	-54.67	207.59	55.00	0.00	0.00	0.00	
10,600.00	5.00	104.75	10,590.46	-56.89	216.02	57.23	0.00	0.00	0.00	
10,700.00	5.00	104.75	10,690.08	-59.11	224.44	59.46	0.00	0.00	0.00	
10,800.00	5.00	104.75	10,789.70	-61.33	232.87	61.69	0.00	0.00	0.00	
10,900.00	5.00	104.75	10,889.32	-63.55	241.30	63.93	0.00	0.00	0.00	
11,000.00	5.00	104.75	10,988.94	-65.77	249.72	66.16	0.00	0.00	0.00	
11,029.17	5.00	104.75	11,018.00	-66.41	252.18	66.81	0.00	0.00	0.00	
3rd Bone Sand										
11,100.00	5.00	104.75	11,088.56	-67.99	258.15	68.39	0.00	0.00	0.00	
11,200.00	5.00	104.75	11,188.18	-70.21	266.58	70.62	0.00	0.00	0.00	
11,300.00	5.00	104.75	11,287.80	-72.42	275.00	72.86	0.00	0.00	0.00	
11,352.40	5.00	104.75	11,340.00	-73.59	279.42	74.03	0.00	0.00	0.00	
Red Hills										
11,400.00	5.00	104.75	11,387.42	-74.64	283.43	75.09	0.00	0.00	0.00	
11,432.05	5.00	104.75	11,419.34	-75.35	286.13	75.80	0.00	0.00	0.00	
11,441.74	4.81	104.75	11,429.00	-75.57	286.93	76.02	2.00	-2.00	0.00	
Wolfcamp										
11,470.83	4.22	104.75	11,458.00	-76.15	289.15	76.60	2.00	-2.00	0.00	
Wolfcamp X										
11,500.00	3.64	104.75	11,487.10	-76.66	291.08	77.12	2.00	-2.00	0.00	
11,565.99	2.32	104.75	11,553.00	-77.53	294.40	77.99	2.00	-2.00	0.00	
Wolfcamp Y										
11,600.00	1.64	104.75	11,586.99	-77.83	295.54	78.30	2.00	-2.00	0.00	
11,600.01	1.64	104.75	11,587.00	-77.83	295.54	78.30	0.01	0.00	0.00	
Wolfcamp A										
11,682.00	0.00	0.00	11,668.98	-78.13	296.67	78.60	2.00	-2.00	0.00	
11,700.00	0.00	0.00	11,686.98	-78.13	296.67	78.60	0.00	0.00	0.00	
11,800.00	0.00	0.00	11,786.98	-78.13	296.67	78.60	0.00	0.00	0.00	

Planning Report

Database:	STRYKER_EDM	Local Co-ordinate Reference:	Well 122H - Slot PLU29 BS 122H SHL
Company:	XTO Energy	TVD Reference:	3364+25 @ 3389.00usft (T E101)
Project:	Eddy County, NM (NAD27) NMEZ Grid	MD Reference:	3364+25 @ 3389.00usft (T E101)
Site:	PLU 29 BS	North Reference:	Grid
Well:	122H	Survey Calculation Method:	Minimum Curvature
Wellbore:	122H Lateral		
Design:	Plan #1		

Planned Survey										
Measured Depth (usft)	Inclination (°)	Azimuth (°)	Vertical Depth (usft)	+N/-S (usft)	+E/-W (usft)	Vertical Section (usft)	Dogleg Rate (°/100ft)	Build Rate (°/100ft)	Turn Rate (°/100ft)	
11,882.00	0.00	0.00	11,868.98	-78.13	296.67	78.60	0.00	0.00	0.00	
11,900.00	1.44	179.90	11,886.98	-78.36	296.67	78.82	8.00	8.00	0.00	
11,950.00	5.44	179.90	11,936.88	-81.36	296.68	81.82	8.00	8.00	0.00	
12,000.00	9.44	179.90	11,986.45	-87.83	296.69	88.29	8.00	8.00	0.00	
12,039.28	12.58	179.90	12,025.00	-95.33	296.70	95.80	8.00	8.00	0.00	
Wolfcamp B										
12,050.00	13.44	179.90	12,035.44	-97.74	296.70	98.21	8.00	8.00	0.00	
12,100.00	17.44	179.90	12,083.63	-111.05	296.73	111.52	8.00	8.00	0.00	
12,150.00	21.44	179.90	12,130.77	-127.69	296.76	128.16	8.00	8.00	0.00	
12,200.00	25.44	179.90	12,176.63	-147.57	296.79	148.04	8.00	8.00	0.00	
12,250.00	29.44	179.90	12,221.00	-170.61	296.83	171.08	8.00	8.00	0.00	
12,300.00	33.44	179.90	12,263.65	-196.69	296.88	197.15	8.00	8.00	0.00	
12,350.00	37.44	179.90	12,304.38	-225.67	296.93	226.14	8.00	8.00	0.00	
12,382.00	40.00	179.90	12,329.34	-245.69	296.96	246.15	8.00	8.00	0.00	
12,400.00	41.80	179.90	12,342.95	-257.47	296.98	257.94	10.00	10.00	0.00	
12,450.00	46.80	179.90	12,378.72	-292.38	297.04	292.85	10.00	10.00	0.00	
12,500.00	51.80	179.90	12,411.31	-330.28	297.11	330.74	10.00	10.00	0.00	
12,510.95	52.89	179.90	12,418.00	-338.94	297.13	339.41	10.00	10.00	0.00	
Wolfcamp D										
12,550.00	56.80	179.90	12,440.48	-370.87	297.18	371.33	10.00	10.00	0.00	
12,600.00	61.80	179.90	12,466.00	-413.85	297.26	414.31	10.00	10.00	0.00	
12,650.00	66.80	179.90	12,487.68	-458.89	297.33	459.35	10.00	10.00	0.00	
12,700.00	71.80	179.90	12,505.35	-505.64	297.42	506.11	10.00	10.00	0.00	
12,750.00	76.80	179.90	12,518.87	-553.76	297.50	554.23	10.00	10.00	0.00	
12,800.00	81.80	179.90	12,528.15	-602.88	297.59	603.34	10.00	10.00	0.00	
12,850.00	86.80	179.90	12,533.12	-652.61	297.67	653.08	10.00	10.00	0.00	
12,878.79	89.68	179.90	12,534.00	-681.38	297.72	681.85	10.00	10.00	0.00	
LP										
12,885.00	90.30	179.90	12,534.00	-687.60	297.73	688.06	10.00	10.00	0.00	
12,900.00	90.30	179.90	12,533.92	-702.60	297.76	703.06	0.00	0.00	0.00	
13,000.00	90.30	179.90	12,533.40	-802.60	297.93	803.06	0.00	0.00	0.00	
13,100.00	90.30	179.90	12,532.88	-902.59	298.11	903.06	0.00	0.00	0.00	
13,200.00	90.30	179.90	12,532.35	-1,002.59	298.28	1,003.06	0.00	0.00	0.00	
13,300.00	90.30	179.90	12,531.83	-1,102.59	298.46	1,103.06	0.00	0.00	0.00	
13,400.00	90.30	179.90	12,531.30	-1,202.59	298.63	1,203.06	0.00	0.00	0.00	
13,500.00	90.30	179.90	12,530.78	-1,302.59	298.81	1,303.06	0.00	0.00	0.00	
13,600.00	90.30	179.90	12,530.26	-1,402.59	298.98	1,403.05	0.00	0.00	0.00	
13,700.00	90.30	179.90	12,529.73	-1,502.58	299.16	1,503.05	0.00	0.00	0.00	
13,800.00	90.30	179.90	12,529.21	-1,602.58	299.33	1,603.05	0.00	0.00	0.00	
13,900.00	90.30	179.90	12,528.69	-1,702.58	299.51	1,703.05	0.00	0.00	0.00	
14,000.00	90.30	179.90	12,528.16	-1,802.58	299.68	1,803.05	0.00	0.00	0.00	
14,100.00	90.30	179.90	12,527.64	-1,902.58	299.85	1,903.05	0.00	0.00	0.00	
14,200.00	90.30	179.90	12,527.12	-2,002.58	300.03	2,003.05	0.00	0.00	0.00	
14,300.00	90.30	179.90	12,526.59	-2,102.58	300.20	2,103.04	0.00	0.00	0.00	
14,400.00	90.30	179.90	12,526.07	-2,202.57	300.38	2,203.04	0.00	0.00	0.00	
14,500.00	90.30	179.90	12,525.55	-2,302.57	300.55	2,303.04	0.00	0.00	0.00	
14,600.00	90.30	179.90	12,525.02	-2,402.57	300.73	2,403.04	0.00	0.00	0.00	
14,700.00	90.30	179.90	12,524.50	-2,502.57	300.90	2,503.04	0.00	0.00	0.00	
14,800.00	90.30	179.90	12,523.97	-2,602.57	301.08	2,603.04	0.00	0.00	0.00	
14,900.00	90.30	179.90	12,523.45	-2,702.57	301.25	2,703.04	0.00	0.00	0.00	
15,000.00	90.30	179.90	12,522.93	-2,802.57	301.43	2,803.04	0.00	0.00	0.00	
15,100.00	90.30	179.90	12,522.40	-2,902.56	301.60	2,903.03	0.00	0.00	0.00	
15,200.00	90.30	179.90	12,521.88	-3,002.56	301.77	3,003.03	0.00	0.00	0.00	

Planning Report

Database:	STRYKER_EDM	Local Co-ordinate Reference:	Well 122H - Slot PLU29 BS 122H SHL
Company:	XTO Energy	TVD Reference:	3364+25 @ 3389.00usft (T E101)
Project:	Eddy County, NM (NAD27) NMEZ Grid	MD Reference:	3364+25 @ 3389.00usft (T E101)
Site:	PLU 29 BS	North Reference:	Grid
Well:	122H	Survey Calculation Method:	Minimum Curvature
Wellbore:	122H Lateral		
Design:	Plan #1		

Planned Survey										
Measured Depth (usft)	Inclination (°)	Azimuth (°)	Vertical Depth (usft)	+N/-S (usft)	+E/-W (usft)	Vertical Section (usft)	Dogleg Rate (°/100ft)	Build Rate (°/100ft)	Turn Rate (°/100ft)	
15,300.00	90.30	179.90	12,521.36	-3,102.56	301.95	3,103.03	0.00	0.00	0.00	
15,400.00	90.30	179.90	12,520.83	-3,202.56	302.12	3,203.03	0.00	0.00	0.00	
15,500.00	90.30	179.90	12,520.31	-3,302.56	302.30	3,303.03	0.00	0.00	0.00	
15,600.00	90.30	179.90	12,519.79	-3,402.56	302.47	3,403.03	0.00	0.00	0.00	
15,700.00	90.30	179.90	12,519.26	-3,502.55	302.65	3,503.03	0.00	0.00	0.00	
15,800.00	90.30	179.90	12,518.74	-3,602.55	302.82	3,603.02	0.00	0.00	0.00	
15,900.00	90.30	179.90	12,518.22	-3,702.55	303.00	3,703.02	0.00	0.00	0.00	
16,000.00	90.30	179.90	12,517.69	-3,802.55	303.17	3,803.02	0.00	0.00	0.00	
16,100.00	90.30	179.90	12,517.17	-3,902.55	303.34	3,903.02	0.00	0.00	0.00	
16,200.00	90.30	179.90	12,516.64	-4,002.55	303.52	4,003.02	0.00	0.00	0.00	
16,300.00	90.30	179.90	12,516.12	-4,102.55	303.69	4,103.02	0.00	0.00	0.00	
16,400.00	90.30	179.90	12,515.60	-4,202.54	303.87	4,203.02	0.00	0.00	0.00	
16,500.00	90.30	179.90	12,515.07	-4,302.54	304.04	4,303.01	0.00	0.00	0.00	
16,600.00	90.30	179.90	12,514.55	-4,402.54	304.22	4,403.01	0.00	0.00	0.00	
16,700.00	90.30	179.90	12,514.03	-4,502.54	304.39	4,503.01	0.00	0.00	0.00	
16,800.00	90.30	179.90	12,513.50	-4,602.54	304.57	4,603.01	0.00	0.00	0.00	
16,900.00	90.30	179.90	12,512.98	-4,702.54	304.74	4,703.01	0.00	0.00	0.00	
17,000.00	90.30	179.90	12,512.46	-4,802.53	304.92	4,803.01	0.00	0.00	0.00	
17,100.00	90.30	179.90	12,511.93	-4,902.53	305.09	4,903.01	0.00	0.00	0.00	
17,200.00	90.30	179.90	12,511.41	-5,002.53	305.26	5,003.01	0.00	0.00	0.00	
17,300.00	90.30	179.90	12,510.88	-5,102.53	305.44	5,103.00	0.00	0.00	0.00	
17,400.00	90.30	179.90	12,510.36	-5,202.53	305.61	5,203.00	0.00	0.00	0.00	
17,500.00	90.30	179.90	12,509.84	-5,302.53	305.79	5,303.00	0.00	0.00	0.00	
17,600.00	90.30	179.90	12,509.31	-5,402.53	305.96	5,403.00	0.00	0.00	0.00	
17,700.00	90.30	179.90	12,508.79	-5,502.52	306.14	5,503.00	0.00	0.00	0.00	
17,800.00	90.30	179.90	12,508.27	-5,602.52	306.31	5,603.00	0.00	0.00	0.00	
17,900.00	90.30	179.90	12,507.74	-5,702.52	306.49	5,703.00	0.00	0.00	0.00	
18,000.00	90.30	179.90	12,507.22	-5,802.52	306.66	5,802.99	0.00	0.00	0.00	
18,100.00	90.30	179.90	12,506.70	-5,902.52	306.84	5,902.99	0.00	0.00	0.00	
18,200.00	90.30	179.90	12,506.17	-6,002.52	307.01	6,002.99	0.00	0.00	0.00	
18,300.00	90.30	179.90	12,505.65	-6,102.52	307.18	6,102.99	0.00	0.00	0.00	
18,400.00	90.30	179.90	12,505.13	-6,202.51	307.36	6,202.99	0.00	0.00	0.00	
18,500.00	90.30	179.90	12,504.60	-6,302.51	307.53	6,302.99	0.00	0.00	0.00	
18,600.00	90.30	179.90	12,504.08	-6,402.51	307.71	6,402.99	0.00	0.00	0.00	
18,700.00	90.30	179.90	12,503.55	-6,502.51	307.88	6,502.98	0.00	0.00	0.00	
18,800.00	90.30	179.90	12,503.03	-6,602.51	308.06	6,602.98	0.00	0.00	0.00	
18,900.00	90.30	179.90	12,502.51	-6,702.51	308.23	6,702.98	0.00	0.00	0.00	
19,000.00	90.30	179.90	12,501.98	-6,802.50	308.41	6,802.98	0.00	0.00	0.00	
19,100.00	90.30	179.90	12,501.46	-6,902.50	308.58	6,902.98	0.00	0.00	0.00	
19,200.00	90.30	179.90	12,500.94	-7,002.50	308.76	7,002.98	0.00	0.00	0.00	
19,300.00	90.30	179.90	12,500.41	-7,102.50	308.93	7,102.98	0.00	0.00	0.00	
19,400.00	90.30	179.90	12,499.89	-7,202.50	309.10	7,202.97	0.00	0.00	0.00	
19,500.00	90.30	179.90	12,499.37	-7,302.50	309.28	7,302.97	0.00	0.00	0.00	
19,600.00	90.30	179.90	12,498.84	-7,402.50	309.45	7,402.97	0.00	0.00	0.00	
19,700.00	90.30	179.90	12,498.32	-7,502.49	309.63	7,502.97	0.00	0.00	0.00	
19,800.00	90.30	179.90	12,497.79	-7,602.49	309.80	7,602.97	0.00	0.00	0.00	
19,900.00	90.30	179.90	12,497.27	-7,702.49	309.98	7,702.97	0.00	0.00	0.00	
20,000.00	90.30	179.90	12,496.75	-7,802.49	310.15	7,802.97	0.00	0.00	0.00	
20,100.00	90.30	179.90	12,496.22	-7,902.49	310.33	7,902.97	0.00	0.00	0.00	
20,179.31	90.30	179.90	12,495.81	-7,981.80	310.46	7,982.28	0.00	0.00	0.00	
20,200.00	90.30	179.90	12,495.70	-8,002.49	310.50	8,002.96	0.00	0.00	0.00	
20,309.32	90.30	179.90	12,495.13	-8,111.80	310.69	8,112.28	0.00	0.00	0.00	

Planning Report

Database:	STRYKER_EDM	Local Co-ordinate Reference:	Well 122H - Slot PLU29 BS 122H SHL
Company:	XTO Energy	TVD Reference:	3364+25 @ 3389.00usft (T E101)
Project:	Eddy County, NM (NAD27) NMEZ Grid	MD Reference:	3364+25 @ 3389.00usft (T E101)
Site:	PLU 29 BS	North Reference:	Grid
Well:	122H	Survey Calculation Method:	Minimum Curvature
Wellbore:	122H Lateral		
Design:	Plan #1		

Design Targets									
Target Name	Dip Angle (°)	Dip Dir. (°)	TVD (usft)	+N/-S (usft)	+E/-W (usft)	Northing (usft)	Easting (usft)	Latitude	Longitude
PLU29 BS 122H SHL - hit/miss target - Shape - Point	0.00	0.00	0.00	0.00	0.00	401,257.70	663,235.20	32° 6' 7.47528042 N	3° 48' 22.23921945 W
PLU29 BS 122H LTP_3 - plan misses target center by 1.11usft at 20179.32usft MD (12495.81 TVD, -7981.80 N, 310.46 E) - Point	0.00	0.00	12,495.00	-7,981.80	309.70	393,275.90	663,544.90	32° 4' 48.47101468 N	3° 48' 19.09313271 W
PLU29 BS 122H PBHL_ - plan misses target center by 0.49usft at 20309.31usft MD (12495.13 TVD, -8111.80 N, 310.69 E) - Rectangle (sides W100.00 H7,425.00 D0.00)	0.00	0.00	12,495.13	-8,111.80	310.20	393,145.90	663,545.40	32° 4' 47.18448579 N	3° 48' 19.09471700 W
PLU29 BS 122H LP - plan hits target center - Point	0.00	0.00	12,534.00	-687.60	297.73	400,570.10	663,532.93	32° 6' 0.65626369 N	3° 48' 18.81711319 W
PLU29 BS 122H FTP_3 - plan misses target center by 0.13usft at 12885.00usft MD (12534.00 TVD, -687.60 N, 297.73 E) - Point	0.00	0.00	12,534.00	-687.60	297.60	400,570.10	663,532.80	32° 6' 0.65626999 N	3° 48' 18.81862448 W

Formations						
Measured Depth (usft)	Vertical Depth (usft)	Name	Lithology	Dip (°)	Dip Direction (°)	
811.00	811.00	Rustler				
1,174.00	1,174.00	Salado				
3,910.00	3,910.00	Base of Salt				
4,124.00	4,124.00	Delaware				
5,114.00	5,114.00	Cherry Canyon				
6,800.00	6,800.00	Brushy Canyon				
7,851.00	7,851.00	Basal Brushy Canyon				
8,066.09	8,066.00	Bone Spring				
8,093.13	8,093.00	Bone Spring Lime				
9,066.71	9,063.00	1st Bone Sand				
9,480.28	9,475.00	2nd Bone Lime				
9,931.00	9,924.00	2nd Bone Sand				
10,153.84	10,146.00	3rd Bone Lime				
11,029.17	11,018.00	3rd Bone Sand				
11,352.40	11,340.00	Red Hills				
11,441.74	11,429.00	Wolfcamp				
11,470.83	11,458.00	Wolfcamp X				
11,565.99	11,553.00	Wolfcamp Y				
11,600.01	11,587.00	Wolfcamp A				
12,039.28	12,025.00	Wolfcamp B				
12,510.95	12,418.00	Wolfcamp D				
12,878.79	12,534.00	LP				

PECOS DISTRICT DRILLING CONDITIONS OF APPROVAL

OPERATOR'S NAME:	XTO Permian Operating, LLC
LEASE NO.:	NMLC-0061634B
WELL NAME & NO.:	Poker Lake Unit 29 BS 122H
SURFACE HOLE FOOTAGE:	2310' FNL & 0690' FWL
BOTTOM HOLE FOOTAGE	0200' FSL & 0990' FWL Sec. 32, T. 25 S., R 31 E.
LOCATION:	Section 29, T. 25 S., R 31 E., NMPM
COUNTY:	Eddy County, New Mexico

Commercial Well Determination

A commercial well determination shall be submitted after production has been established for at least six months.

Unit Wells

The well sign for a unit well shall include the unit number in addition to the surface and bottom hole lease numbers. This also applies to participating area numbers. If a participating area has not been established, the operator can use the general unit designation, but will replace the unit number with the participating area number when the sign is replaced.

A. DRILLING OPERATIONS REQUIREMENTS

The BLM is to be notified in advance for a representative to witness:

- a. Spudding well (minimum of 24 hours)
- b. Setting and/or Cementing of all casing strings (minimum of 4 hours)
- c. BOPE tests (minimum of 4 hours)

Eddy County

Call the Carlsbad Field Office, 620 East Greene St., Carlsbad, NM 88220,
(575) 361-2822

1. **Hydrogen Sulfide (H₂S) monitors shall be installed prior to drilling out the surface shoe. If H₂S is detected in concentrations greater than 100 ppm, the Hydrogen Sulfide area shall meet Onshore Order 6 requirements, which includes equipment and personnel/public protection items. If Hydrogen Sulfide is encountered, provide measured values and formations to the BLM.**
2. Unless the production casing has been run and cemented or the well has been properly plugged, the drilling rig shall not be removed from over the hole without prior approval. **If the drilling rig is removed without approval – an Incident of Non-Compliance will be written and will be a “Major” violation.**

3. The operator has proposed to drill multiple wells utilizing a skid/walking rig. Operator shall secure the wellbore on the current well, after installing and testing the wellhead, by installing a blind flange of like pressure rating to the wellhead and a pressure gauge that can be monitored while drilling is performed on the other well.
4. Floor controls are required for 3M or Greater systems. These controls will be on the rig floor, unobstructed, readily accessible to the driller and will be operational at all times during drilling and/or completion activities. Rig floor is defined as the area immediately around the rotary table; the area immediately above the substructure on which the draw works is located; this does not include the dog house or stairway area.
5. The record of the drilling rate along with the GR/N well log run from TD to surface (horizontal well – vertical portion of hole) shall be submitted to the BLM office as well as all other logs run on the borehole 30 days from completion. If available, a digital copy of the logs is to be submitted in addition to the paper copies. The Rustler top and top and bottom of Salt are to be recorded on the Completion Report.

B. CASING

Changes to the approved APD casing program need prior approval if the items substituted are of lesser grade or different casing size or are Non-API. The Operator can exchange the components of the proposal with that of superior strength (i.e. changing from J-55 to N-80, or from 36# to 40#). Changes to the approved cement program need prior approval if the altered cement plan has less volume or strength or if the changes are substantial (i.e. Multistage tool, ECP, etc.). The initial wellhead installed on the well will remain on the well with spools used as needed.

Centralizers required on surface casing per Onshore Order 2.III.B.1.f.

Wait on cement (WOC) for Water Basin:

After cementing but before commencing any tests, the casing string shall stand cemented under pressure until both of the following conditions have been met: 1) cement reaches a minimum compressive strength of 500 psi at the shoe, 2) until cement has been in place at least 8 hours. WOC time will be recorded in the driller's log. See individual casing strings for details regarding lead cement slurry requirements.

Provide compressive strengths including hours to reach required 500 pounds compressive strength prior to cementing each casing string. Have well specific cement details onsite prior to pumping the cement for each casing string.

No pea gravel permitted for remedial or fall back remedial without prior authorization from the BLM engineer.

Medium Cave/Karst

Possibility of water flows in the Salado and Castile.

Possibility of lost circulation in the Red Beds, Rustler, and Delaware.

Abnormal pressure may be encountered in the 3rd Bone Spring and all subsequent formations.

1. The 13-3/8 inch surface casing shall be set at approximately 1050 feet (a minimum of 25 feet into the Rustler Anhydrite and above the salt) and cemented to the surface. **If salt is encountered, set casing at least 25 feet above the salt.**
 - a. If cement does not circulate to the surface, the appropriate BLM office shall be notified and a temperature survey utilizing an electronic type temperature survey with surface log readout will be used or a cement bond log shall be run to verify the top of the cement. Temperature survey will be run a minimum of six hours after pumping cement and ideally between 8-10 hours after completing the cement job.
 - b. **Wait on cement (WOC) time for a primary cement job is to include the lead cement slurry.**
 - c. Wait on cement (WOC) time for a remedial job will be a minimum of 4 hours after bringing cement to surface or 500 pounds compressive strength, whichever is greater.
 - d. If cement falls back, remedial cementing will be done prior to drilling out that string.

Formation below the 13-3/8" shoe to be tested according to Onshore Order

2.III.B.1.i. Test to be done as a mud equivalency test using the mud weight necessary for the pore pressure of the formation below the shoe and the mud weight for the bottom of the hole. Report results to BLM office.

2. The minimum required fill of cement behind the 9-5/8 inch intermediate casing is:

- Cement to surface. If cement does not circulate see B.1.a, c-d above. **Wait on cement (WOC) time for a primary cement job is to include the lead cement slurry due to cave/karst.**

If cement does not circulate to surface on the intermediate casing, the cement on the production casing must come to surface.

Formation below the 9-5/8" shoe to be tested according to Onshore Order 2.III.B.1.i. Test to be done as a mud equivalency test using the mud weight necessary for the pore pressure of the formation below the shoe (not the mud weight required to prevent dissolving the salt formation) and the mud weight for the bottom of the hole. Report results to BLM office.

Centralizers required through the curve and a minimum of one every other joint.

3. The minimum required fill of cement behind the 7 inch production casing is:

- Cement should tie-back at least 200 feet into previous casing string. Operator shall provide method of verification.

Formation below the 7" shoe to be tested according to Onshore Order 2.III.B.1.i. Test to be done as a mud equivalency test using the mud weight necessary for the pore pressure of the formation below the shoe and the mud weight for the bottom of the hole. Report results to BLM office.

4. The minimum required fill of cement behind the 4-1/2 inch production Liner is:

- Cement as proposed. Operator shall provide method of verification.

5. If hardband drill pipe is rotated inside casing, returns will be monitored for metal. If metal is found in samples, drill pipe will be pulled and rubber protectors which have a larger diameter than the tool joints of the drill pipe will be installed prior to continuing drilling operations.

C. PRESSURE CONTROL

1. All blowout preventer (BOP) and related equipment (BOPE) shall comply with well control requirements as described in Onshore Oil and Gas Order No. 2 and API 53.
2. Variance approved to use flex line from BOP to choke manifold. Check condition of flexible line from BOP to choke manifold, replace if exterior is damaged or if line fails test. Line to be as straight as possible with no hard bends and is to be anchored according to Manufacturer's requirements. The flexible hose can be exchanged with a hose of equal size and equal or greater pressure rating. **Anchor requirements, specification sheet and hydrostatic pressure test certification matching the hose in service, to be onsite for review. These documents shall be posted in the company man's trailer and on the rig floor.** If the BLM inspector questions the straightness of the hose, a BLM engineer will be contacted and will review in the field or via picture supplied by inspector to determine if changes are required (operator shall expect delays if this occurs).

3. Operator has proposed a multi-bowl wellhead assembly. This assembly will only be tested when installed on the surface casing. Minimum working pressure of the blowout preventer (BOP) and related equipment (BOPE) required for drilling below the surface casing shoe shall be 10,000 (10M) psi.
 - a. Wellhead shall be installed by manufacturer's representatives, submit documentation with subsequent sundry.
 - b. If the welding is performed by a third party, the manufacturer's representative shall monitor the temperature to verify that it does not exceed the maximum temperature of the seal.
 - c. Manufacturer representative shall install the test plug for the initial BOP test.
 - d. Operator shall perform the 9-5/8" and 7" casing integrity tests to 70% of the casing burst. This will test the multi-bowl seals.
 - e. If the cement does not circulate and one inch operations would have been possible with a standard wellhead, the well head shall be cut off, cementing operations performed and another wellhead installed.

Variance approved to use a 5M annular. The annular must be tested to full working pressure (5000 psi.)

10M system requires an HCR valve, remote kill line and annular to match. The remote kill line is to be installed prior to testing the system and tested to stack pressure.

4. The appropriate BLM office shall be notified a minimum of 4 hours in advance for a representative to witness the tests.
 - a. In a water basin, for all casing strings utilizing slips, these are to be set as soon as the crew and rig are ready and any fallback cement remediation has been done. The casing cut-off and BOP installation can be initiated four hours after installing the slips, which will be approximately six hours after bumping the plug. For those casing strings not using slips, the minimum wait time before cut-off is eight hours after bumping the plug. BOP/BOPE testing can begin after cut-off or once cement reaches 500 psi compressive strength (including lead when specified), whichever is greater. However, if the float does not hold, cut-off cannot be initiated until cement reaches 500 psi compressive strength (including lead when specified).
 - b. The tests shall be done by an independent service company utilizing a test plug **not a cup or J-packer**.
 - c. The test shall be run on a 5000 psi chart for a 2-3M BOP/BOP, on a 10000 psi chart for a 5M BOP/BOPE and on a 15000 psi chart for a 10M BOP/BOPE. If a linear chart is used, it shall be a one hour chart. A circular chart shall have a maximum 2 hour clock. If a twelve hour or twenty-four hour chart is used, tester shall make a notation that it is run with a two hour clock.

- d. The results of the test shall be reported to the appropriate BLM office.
- e. All tests are required to be recorded on a calibrated test chart. **A copy of the BOP/BOPE test chart and a copy of independent service company test will be submitted to the appropriate BLM office.**
- f. The BOP/BOPE test shall include a low pressure test from 250 to 300 psi. The test will be held for a minimum of 10 minutes if test is done with a test plug and 30 minutes without a test plug. This test shall be performed prior to the test at full stack pressure.
- g. BOP/BOPE must be tested by an independent service company within 500 feet of the top of the **Wolfcamp** formation if the time between the setting of the intermediate casing and reaching this depth exceeds 20 days. This test does not exclude the test prior to drilling out the casing shoe as per Onshore Order No. 2.

D. DRILLING MUD

Mud system monitoring equipment, with derrick floor indicators and visual and audio alarms, shall be operating before drilling into the **Wolfcamp** formation, and shall be used until production casing is run and cemented.

E. DRILL STEM TEST

If drill stem tests are performed, Onshore Order 2.III.D shall be followed.

F. WASTE MATERIAL AND FLUIDS

All waste (i.e. drilling fluids, trash, salts, chemicals, sewage, gray water, etc.) created as a result of drilling operations and completion operations shall be safely contained and disposed of properly at a waste disposal facility. No waste material or fluid shall be disposed of on the well location or surrounding area.

Porto-johns and trash containers will be on-location during fracturing operations or any other crew-intensive operations.

JAM 120519