

Rh

OCD Artesia

RECEIVED
APR 13 2010
NMOCD ARTESIA

ATS-10-327

Form 3160-3
(April 2004)

FORM APPROVED
OMB No 1004-0137
Expires March 31, 2007

UNITED STATES
DEPARTMENT OF THE INTERIOR
BUREAU OF LAND MANAGEMENT

APPLICATION FOR PERMIT TO DRILL OR REENTER

5 Lease Serial No 067144	
6 If Indian, Allottee or Tribe Name	
7 If Unit or CA Agreement, Name and No	
8 Lease Name and Well No North Indian Flats 25 Federal #3	
9 API Well No 30-015-37775	
1a Type of work <input checked="" type="checkbox"/> DRILL <input type="checkbox"/> REENTER	10 Field and Pool, or Exploratory Undesignated (Delaware)
1b Type of Well <input checked="" type="checkbox"/> Oil Well <input type="checkbox"/> Gas Well <input type="checkbox"/> Other <input checked="" type="checkbox"/> Single Zone <input type="checkbox"/> Multiple Zone	11 Sec, T R M or Blk and Survey or Area Sec 25, T21S-R28E
2 Name of Operator BOPCO, L. P.	12 County or Parish Eddy County
3a Address P. O. Box 2760 Midland, TX 79702	13 State NM
3b Phone No (include area code) 432-683-2277	14 Distance in miles and direction from nearest town or post office* 6 miles east of Carlsbad
4 Location of Well (Report location clearly and in accordance with any State requirements *) At surface NENE, UL A, 610' FNL, 330' FEL, Lat N32.456808, Long W104.032458 At proposed prod zone Same	15 Distance from proposed* location to nearest property or lease line, ft (Also to nearest drg unit line, if any) 330'
16 No of acres in lease 1280	17 Spacing Unit dedicated to this well 40
18 Distance from proposed location* to nearest well, drilling, completed, applied for, on this lease, ft 1361'	19 Proposed Depth 3400'
20 BLM/BIA Bond No on file COB000050	21 Elevations (Show whether DF, KDB, RT, GL, etc) 3232'
22 Approximate date work will start* 09/25/2010	23 Estimated duration 8 Days

24. Attachments

The following, completed in accordance with the requirements of Onshore Oil and Gas Order No 1, shall be attached to this form

- 1 Well plat certified by a registered surveyor
- 2 A Drilling Plan
- 3 A Surface Use Plan (if the location is on National Forest System Lands, the SUPO shall be filed with the appropriate Forest Service Office)
- 4 Bond to cover the operations unless covered by an existing bond on file (see Item 20 above)
- 5 Operator certification
- 6 Such other site specific information and/or plans as may be required by the authorized officer

25 Signature <i>Annette Childers</i>	Name (Printed/Typed) Annette Childers	Date 2.25.2010
Title Regulatory Clerk		

Approved by (Signature) <i>/s/ Don Peterson</i>	Name (Printed/Typed) Don Peterson	Date APR 07 2010
Title FIELD MANAGER		Office CARLSBAD FIELD OFFICE

Application approval does not warrant or certify that the applicant holds legal or equitable title to those rights in the subject lease which would entitle the applicant to conduct operations thereon
Conditions of approval, if any, are attached

APPROVAL FOR TWO YEARS

Title 18 USC Section 1001 and Title 43 USC Section 1212, make it a crime for any person knowingly and willfully to make to any department or agency of the United States any false, fictitious or fraudulent statements or representations as to any matter within its jurisdiction

*(Instructions on page 2)

Capitan Controlled Water Basin

SEE ATTACHED FOR
CONDITIONS OF APPROVAL

MNR
APPROVAL SUBJECT TO
GENERAL REQUIREMENTS
AND SPECIAL STIPULATIONS
ATTACHED

DISTRICT I
1625 N French Dr. Hobbs, NM 88240

DISTRICT II
1301 W. Grand Avenue, Artesia, NM 88210

DISTRICT III
1000 Rio Brazos Rd., Aztec, NM 87410

DISTRICT IV
1220 S. St. Francis Dr., Santa Fe, NM 87505

State of New Mexico
Energy, Minerals and Natural Resources Department

Form C-102
Revised October 15, 2009

Submit one copy to appropriate
District Office

OIL CONSERVATION DIVISION
1220 South St. Francis Dr.
Santa Fe, New Mexico 87505

WELL LOCATION AND ACREAGE DEDICATION PLAT

AMENDED REPORT

API Number 30-015-31775	Pool Code	Pool Name Undesignated (Delaware)
Property Code 306410 38017	Property Name NORTH INDIAN FLATS "25" FEDERAL	Well Number 3
OGRID No 260737	Operator Name BOPCO, L.P.	Elevation 3232'

Surface Location

UL or lot No.	Section	Township	Range	Lot Idn	Feet from the	North/South line	Feet from the	East/West line	County
A	25	21 S	28 E		610	NORTH	330	EAST	EDDY

Bottom Hole Location If Different From Surface

UL or lot No	Section	Township	Range	Lot Idn	Feet from the	North/South line	Feet from the	East/West line	County

Dedicated Acres 40	Joint or Infill N	Consolidation Code	Order No.
-----------------------	----------------------	--------------------	-----------

NO ALLOWABLE WILL BE ASSIGNED TO THIS COMPLETION UNTIL ALL INTERESTS HAVE BEEN CONSOLIDATED OR A NON-STANDARD UNIT HAS BEEN APPROVED BY THE DIVISION

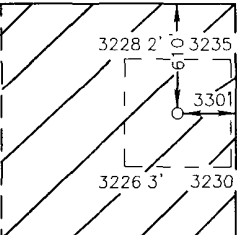
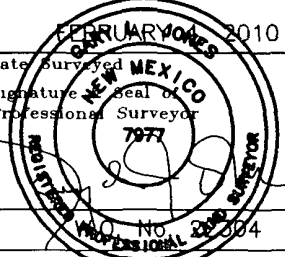
<p>SURFACE LOCATION Lat - N 32°27'24.51" Long - W 104°01'56.85" NMSPC - N 530048.091 E 634139.594 (NAD-83)</p> 	<p>OPERATOR CERTIFICATION</p> <p>I hereby certify that the information contained herein is true and complete to the best of my knowledge and belief, and that this organization either owns a working interest or unleased mineral interest in the land including the proposed bottom hole location or has a right to drill this well at this location pursuant to a contract with an owner of such a mineral or working interest, or to a voluntary pooling agreement or a compulsory pooling order heretofore entered by the division.</p> <p><i>Gary E. Gerhard</i> 2/05/10 Signature Date</p> <p>Gary E. Gerhard Printed Name</p>
	<p>SURVEYOR CERTIFICATION</p> <p>I hereby certify that the well location shown on this plat was plotted from field notes of actual surveys made by me or under my supervision and that the same is true and correct to the best of my belief</p>
	<p>Date surveyed FEBRUARY 05, 2010</p> <p>Signature Seal of Professional Surveyor </p>
	<p>Certificate No. Gary L. Jones 7977</p> <p>BASIN SURVEYS</p>

SECTION 25, TOWNSHIP 21 SOUTH, RANGE 28 EAST, N.M.P.M.,
 EDDY COUNTY, NEW MEXICO.

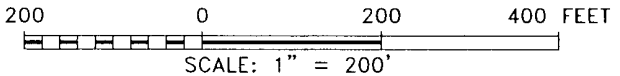
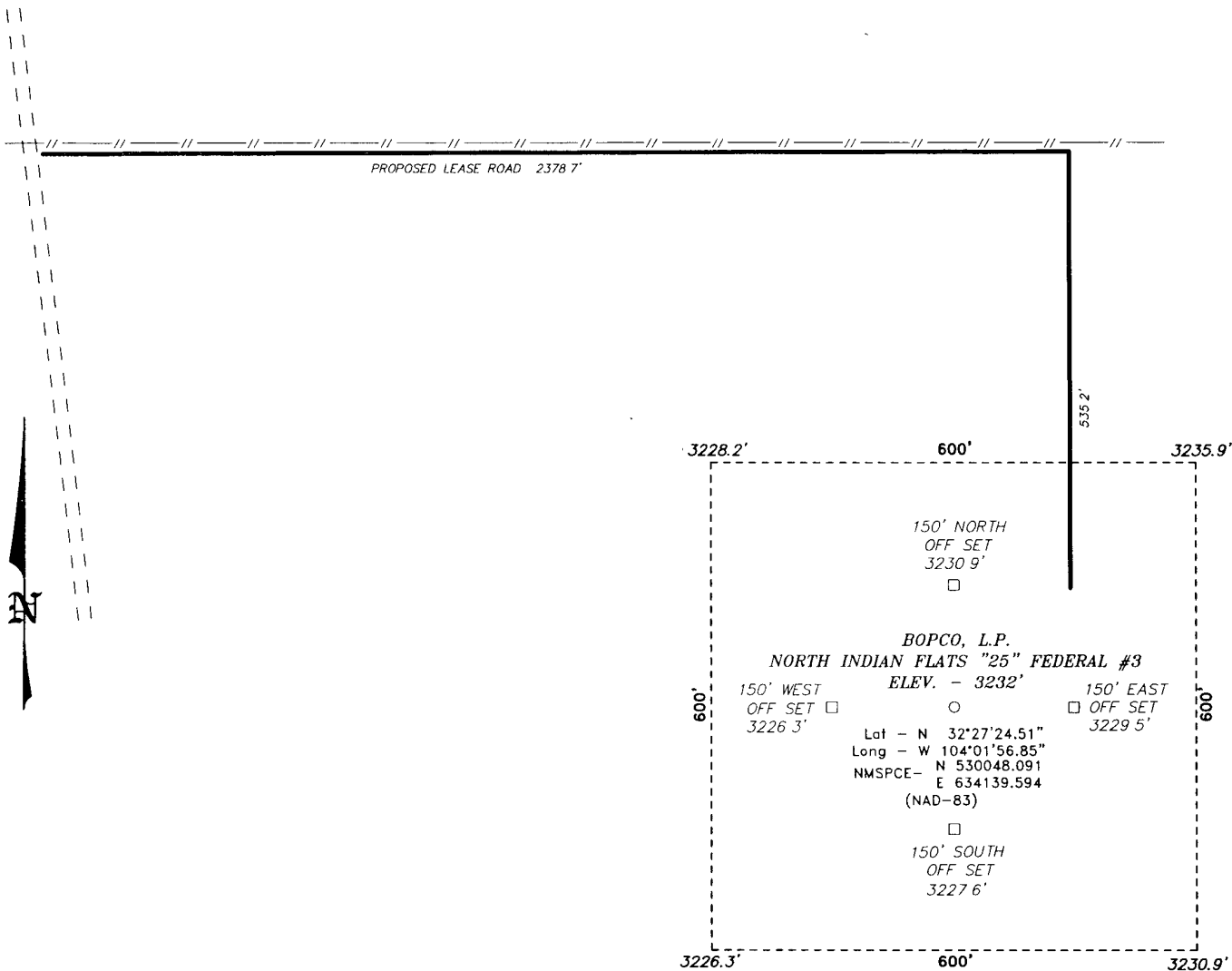

Directions to Location

FROM MILE MARKER 42 OF HWY 62-180, GO WEST
 0.6 MILES TO LEASE ROAD, ON LEASE ROAD GO
 SOUTH 4.4 MILES THENCE EAST 2.0 MILES TO LEASE
 ROAD, ON LEASE ROAD GO NORTH 2.9 MILES TO
 PROPOSED LEASE ROAD

BOPCO, L.P.	
REF NORTH INDIAN FLATS "25" FEDERAL #3 / WELL PAD TOPO	
THE NORTH INDIAN FLATS "25" FEDERAL #3 LOCATED 610' FROM THE NORTH LINE AND 330' FROM THE EAST LINE OF SECTION 25, TOWNSHIP 21 SOUTH, RANGE 28 EAST, N.M.P.M., EDDY COUNTY, NEW MEXICO.	
W.O. Number 22304	Drawn By J. SMALL
Date: 02-04-2010	Disk: JMS 22304
Survey Date 02-04-2010	Sheet 1 of 1 Sheets

BASIN SURVEYS P O BOX 1786 - HOBBS, NEW MEXICO

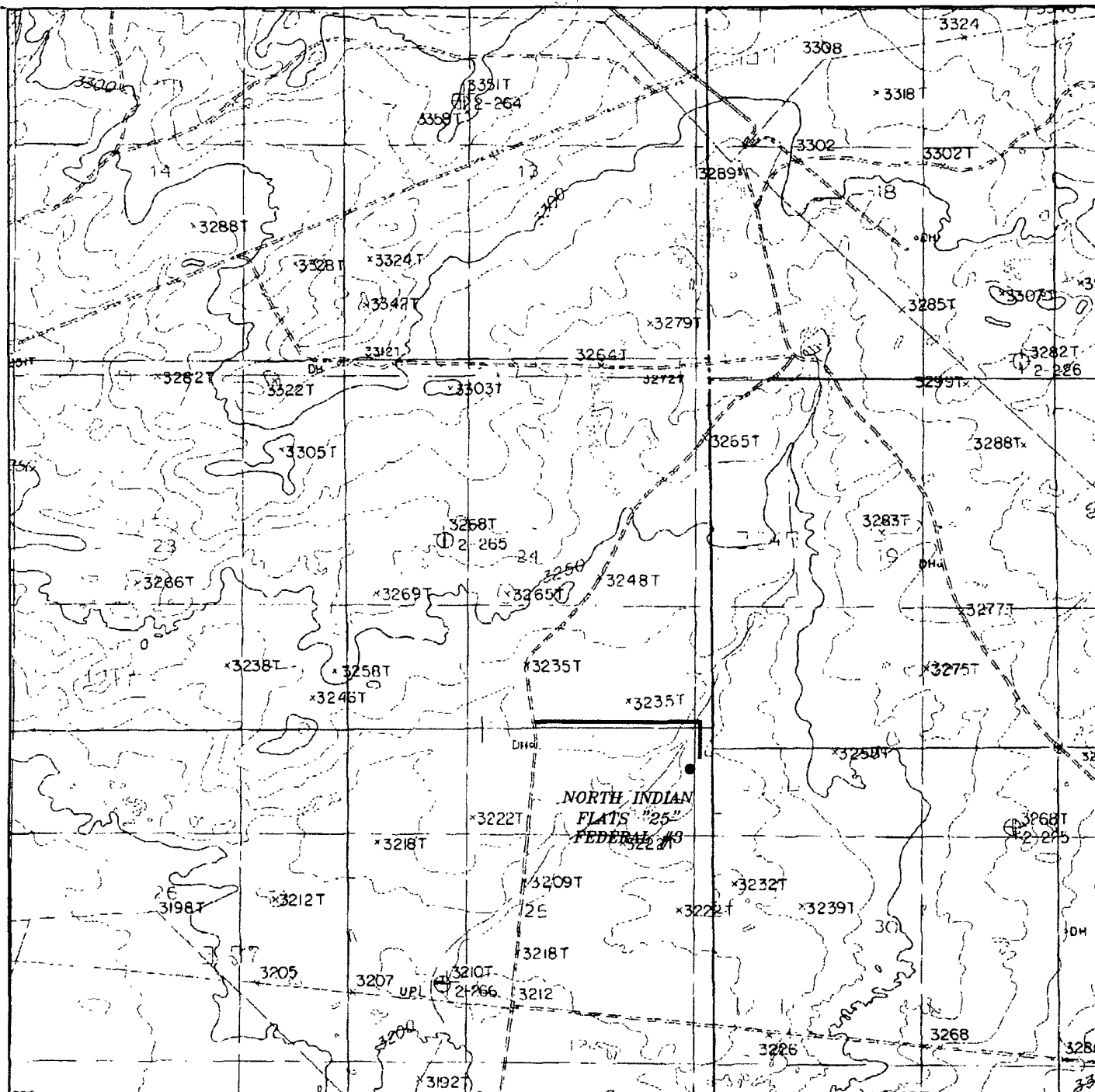

NORTH INDIAN FLATS "25" FEDERAL #3

Located 610' FNL and 330' FEL

Section 25, Township 21 South, Range 28 East,
N.M.P.M., Eddy County, New Mexico.



focused on excellence
in the oilfield

P.O. Box 1786
1120 N. West County Rd.
Hobbs, New Mexico 88241
(575) 393-7316 - Office
(575) 392-2206 - Fax
basinsurveys.com

W.O. Number JMS 22304

Survey Date 02-04-2010

Scale 1" = 2000'

Date 02-11-2010

BOPCO, L.P.

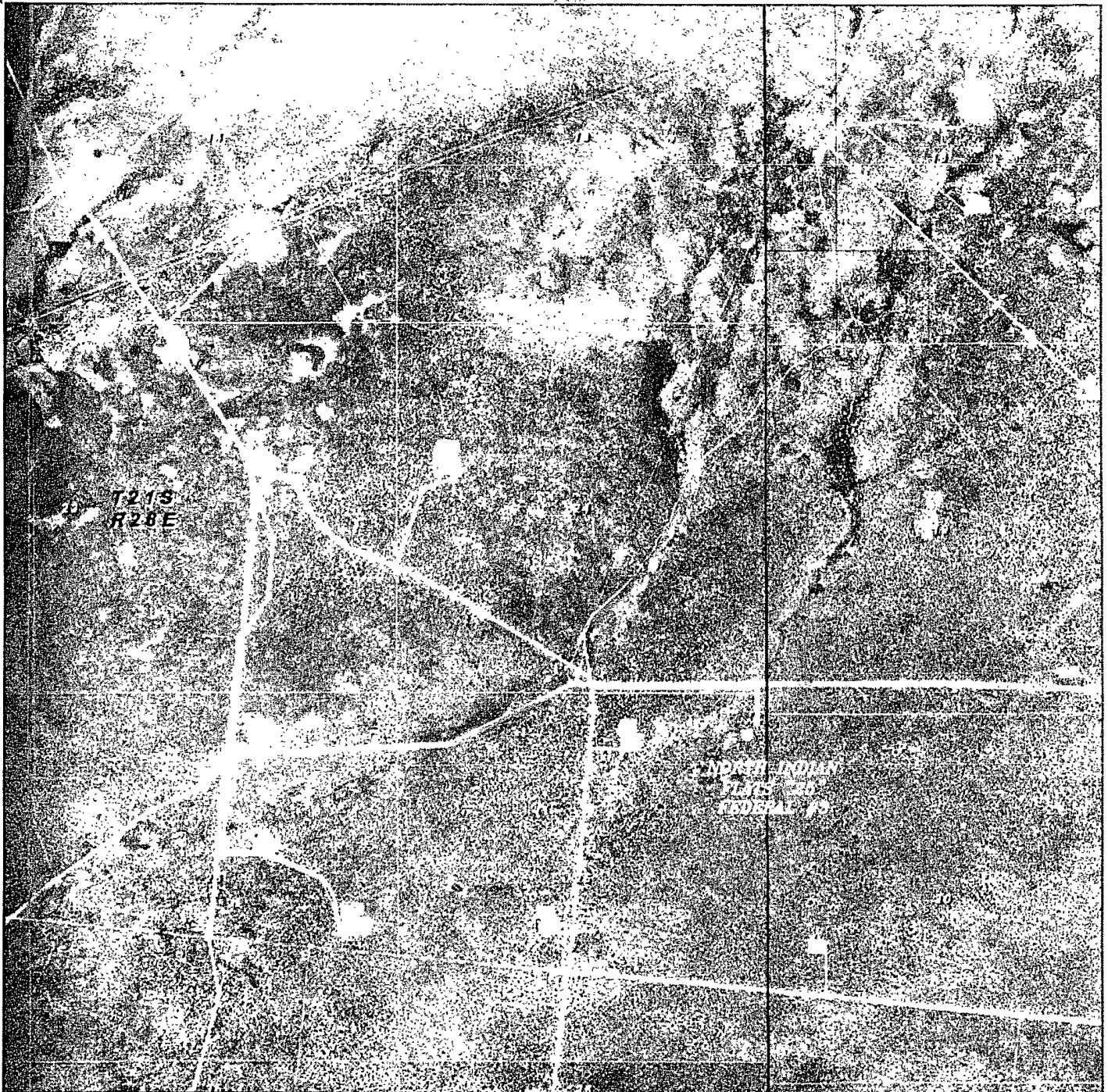

NORTH INDIAN FLATS "25" FEDERAL #3
Located 610' FNL and 330' FEL
Section 25, Township 21 South, Range 28 East,
N.M.P.M., Eddy County, New Mexico.

basin
SURVEYS
focused on excellence
in the oilfield

P.O. Box 1786
1120 N. West County Rd.
Hobbs, New Mexico 88241
(575) 393-7316 - Office
(575) 392-2206 - Fax
basinsurveys.com

Well Number JMS 22304

Scale 1" = 2000'

YELLOW TINT - USA LAND
BLUE TINT - STATE LAND
NATURAL COLOR - FEE LAND



BOPCO, L.P.

North Indian Flats 25 Fed #3
Exhibit "E"

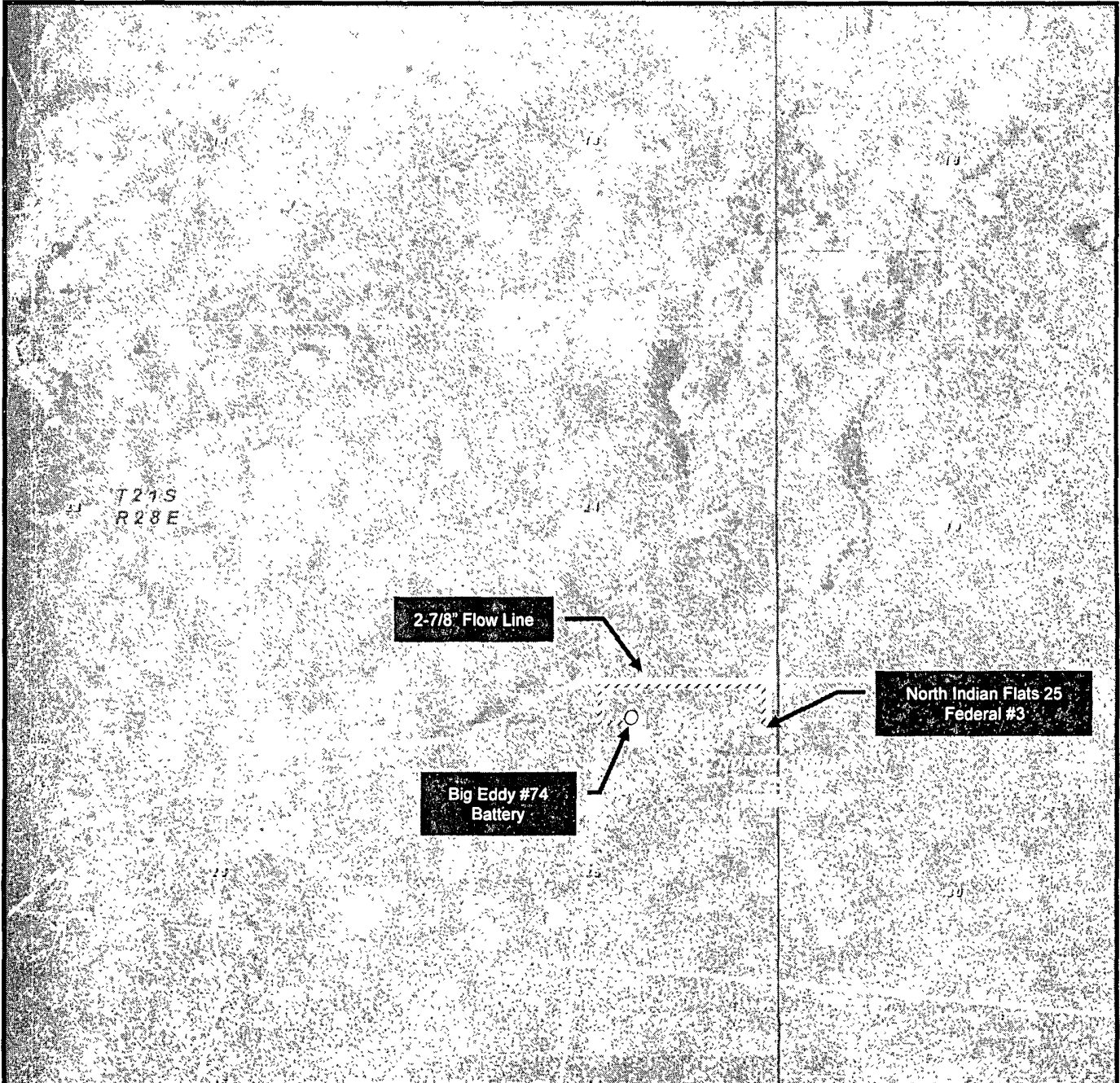

NORTH INDIAN FLATS "25" FEDERAL #3
Located 616' FNL and 330' FEL
Section 25, Township 21 South, Range 28 East,
N.M.L.S., Eddy County, New Mexico.

Surface casing to be set into the Rustler below all fresh water sands.

Production casing will be cemented using Schlumberger TXI LiteWate plus additives with TOC @ 2293'.

Drilling procedure, BOP diagram, anticipated tops and surface plans attached.

This well is located outside the Secretary's Potash area and outside the R-111 Potash area. There are potash leases within 5 miles of the location. (4 miles southeast)

BOPCO, L.P., at P. O. Box 2760, Midland, TX, 79702 is a division office of BOPCO, L.P., 201 Main Street, Ft. Worth, TX 76102, Bond No. COB000050 (Nationwide).

**EIGHT POINT DRILLING PROGRAM
BOPCO, L.P.**

NAME OF WELL: North Indian Flats 25 Federal #3

LEGAL DESCRIPTION - SURFACE: 610' FNL & 330' FEL, Section 25, T21S, R28E, Eddy County, New Mexico.

POINT 1: ESTIMATED FORMATION TOPS

(See No. 2 Below)

POINT 2: WATER, OIL, GAS AND/OR MINERAL BEARING FORMATIONS

Anticipated Formation Tops KB 3243'
GL 3232'

<u>FORMATION</u>	<u>ESTIMATED TOP FROM KB</u>	<u>ESTIMATED SUBSEA TOP</u>	<u>BEARING</u>
T/Rustler	Surface'		Barren
B/Rustler	393'	+ 2,850'	Barren
T/Salt	453'	+ 2,790'	Barren
B/Salt	2,293'	+ 950'	Barren
T/Delaware Mtn Grp	2,689'	+ 544'	Oil/Gas
Clean Carb above R. Sd.	2,818'	+ 425'	Oil/Gas
T/Ramsey Sand	2,846'	+ 397'	Oil/Gas
TD	3,400'	- 157'	Oil/Gas

POINT 3: CASING PROGRAM

<u>TYPE</u>	<u>HOLE SIZE</u>	<u>INTERVALS</u>	<u>PURPOSE</u>	<u>CONDITION</u>
14"	20"	0' - 40'	Conductor	Contractor Discretion
8 5/8", 24#, K-55, 8rd STC	12-1/4"	0' - 443'	Surface	New
5-1/2", 14#, K-55, 8rd STC	7-7/8"	0' - 3,400'	Production	New

CASING DESIGN SAFETY FACTORS:

<u>TYPE</u>	<u>TENSION</u>	<u>COLLAPSE</u>	<u>BURST</u>
8-5/8", 24#, K-55, 8rd STC	28.77	6.62	6.66
5-1/2", 14#, K-55, 8rd STC	4.66	1.76	1.42

DESIGN CRITERIA AND CASING LOADING ASSUMPTIONS:

SURFACE CASING

Tension A 1.6 design factor utilizing the effects of buoyancy (9.2 ppg).

Collapse A 1.0 design factor with full internal evacuation and a collapse force equal to the mud gradient in which the casing will be run (0.48 psi/ft). The effects of axial load on collapse will be considered.

DESIGN CRITERIA AND CASING LOADING ASSUMPTIONS: - con't...

Burst A 1.3 design factor with a surface pressure equal to the fracture gradient at setting depth less a gas gradient to the surface. Internal burst force at the shoe will be fracture pressure at that depth. Backup pressure will be formation pore pressure. In all cases a conservative fracture pressure will be used such that it represents the upper limit of potential fracture resistance up to a 1.0 psi/ft gradient. The effects of tension on burst will not be utilized.

PRODUCTION CASING

Tension A 1.6 design factor utilizing the effects of buoyancy (10.0 ppg).

Collapse A 1.0 design factor with full internal evacuation and a collapse force equal to the mud gradient in which the casing will be run (0.52 psi/ft). The effects of axial load on collapse will be considered.

Burst A 1.25 design factor with anticipated maximum tubing pressure (3000 psig) on top of the maximum anticipated packer fluid gradient. Backup on production strings will be formation pore pressure (0.43 psi/ft). The effects of tension on burst will not be utilized.

POINT 4: PRESSURE CONTROL EQUIPMENT (SEE ATTACHED DIAGRAM)

A BOP equivalent to Diagram 1 will be nipped up on the surface casing head. The BOP stack, blind and pipe rams, chokes, kill line, Upper and lower Kelly valves, inside BOP, choke manifold when rigged up on the surface casing will be tested to 2000 psig (working pressure of BOPE) by independent tester. 8-5/8" casing will be tested to 1500 psig.

These tests will be performed:

- a) When initially installed
- b) Whenever any seal subject to test pressure is broken
- c) Following related repairs
- d) At 30 day intervals

A function test to insure that the preventers are operating correctly will be performed on each trip. See the attached Diagram 1 for the minimum criteria for the choke manifold.

POINT 5: MUD PROGRAM

<u>DEPTH</u>	<u>MUD TYPE</u>	<u>WEIGHT</u>	<u>FV</u>	<u>PV</u>	<u>YP</u>	<u>FL</u>	<u>Ph</u>
0' - 443'	FW	8.5 - 9.2	45-35	NC	NC	NC	9.5
443' - 3,400'	BW	10.0 - 10.3	28-30	NC	NC	NC	9.5

POINT 6: TECHNICAL STAGES OF OPERATION**A) TESTING**

No drill stem tests are planned

POINT 6: TECHNICAL STAGES OF OPERATION - con't...B) LOGGING *See COA*

Run #1
Pex (GR-CNL/LDT) @ TD. GR/CNL to surface.

C) CORING

No cores are anticipated.

D) CEMENT

<u>INTERVAL</u>	<u>AMOUNT SX</u>	<u>FT OF FILL</u>	<u>TYPE</u>	<u>GALS/SX</u>	<u>PPG</u>	<u>FT³/SX</u>
SURFACE Lead 0'-443' (100% excess) (Circulated to surface)	310	443	Class-C + 2% CaCl	6.39	14.8	1.35
<i>see COA</i> PRODUCTION Tail 2,293'-3,400' (100% excess)	270	1107	TXI LiteWate + 0.2% NaCl + 0.3% D167 + 0.15% DO65 + 0.125 pps D130 + 3 pps DO42	7.04	13.0	1.41

E) DIRECTIONAL DRILLING

No directional services anticipated.

POINT 7: ANTICIPATED RESERVOIR CONDITIONS

Normal pressures are anticipated throughout the Delaware section. A BHP of 1472 psi (max) or MWE of 8.33 ppg is expected. The Ramsey production does contain H₂S. A H₂S contingency plan covering all of Sec 24 & 25 will be submitted separately.

POINT 8: OTHER PERTINENT INFORMATION

A) Auxiliary Equipment

Upper and lower kelly cocks. Full opening stab in valve on the rig floor.

B) Anticipated Starting Date

Spud date is 9/25/2010.

8 days drilling operations

7 days completion operations

GEG/mac

North Indian Flats 25 Fed #3 Exhibit "D"



BOPCO, L.P.
RIG LAYOUT SCHEMATIC
INCLUSIVE OF CLOSED-LOOP DESIGN PLAN
CAPSTAR TYPE RIG

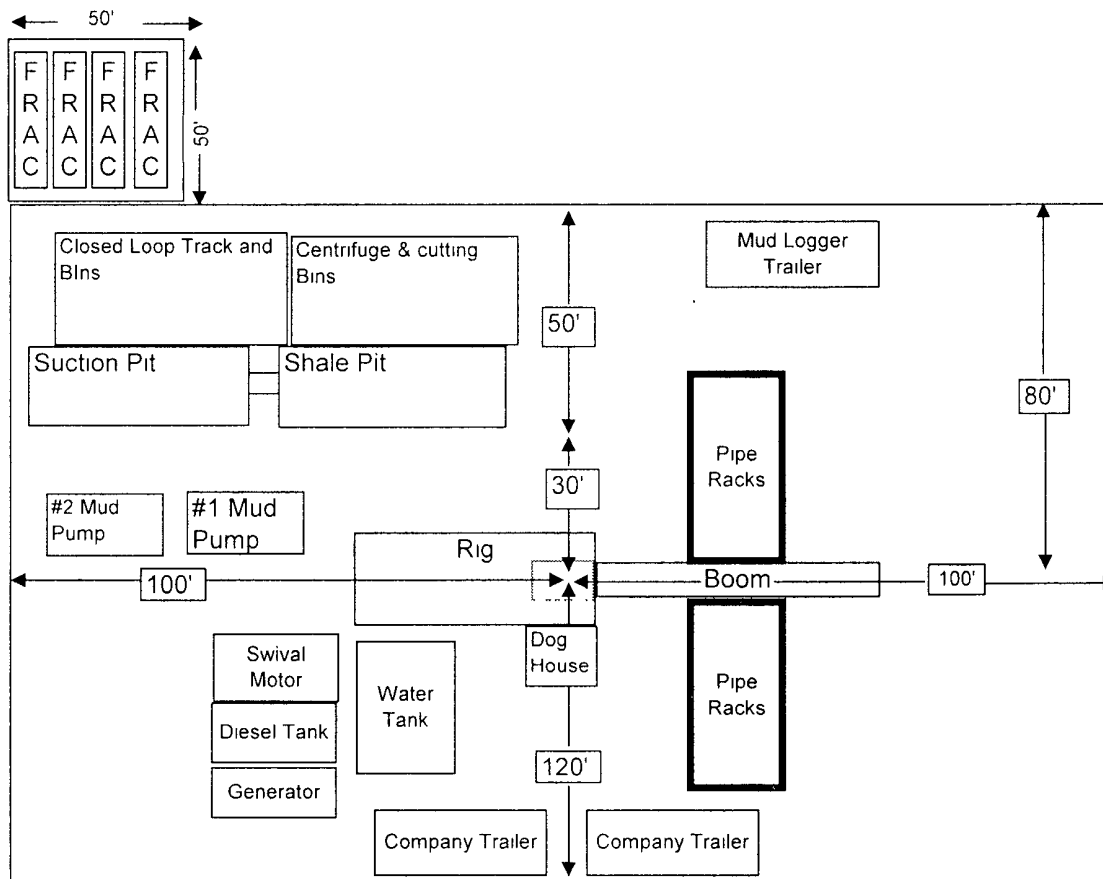

BOPCO, L. P. 2000 PSI WP

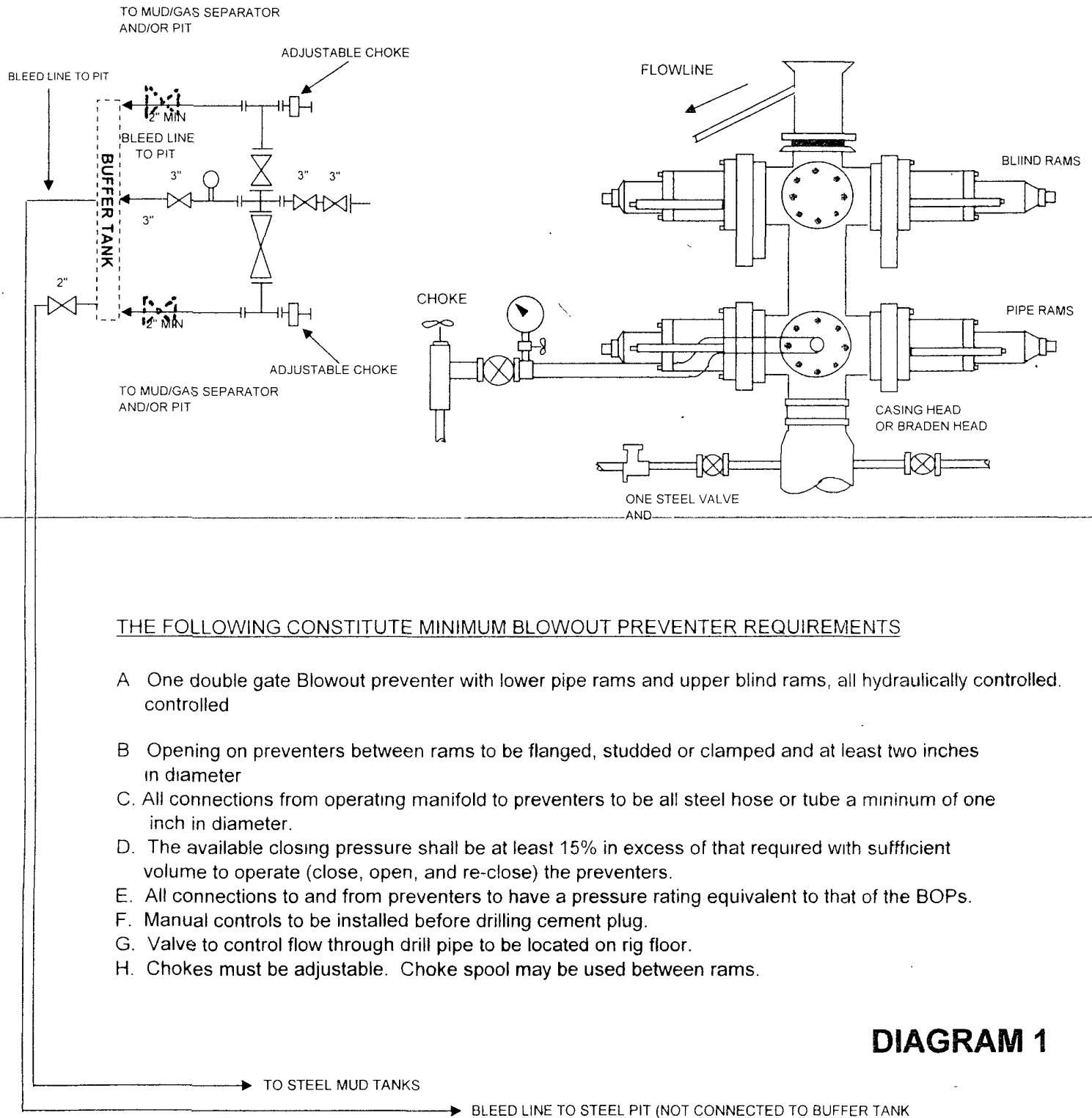

THE FOLLOWING CONSTITUTE MINIMUM BLOWOUT PREVENTER REQUIREMENTS

- A. One double gate Blowout preventer with lower pipe rams and upper blind rams, all hydraulically controlled.
- B. Opening on preventers between rams to be flanged, studded or clamped and at least two inches in diameter
- C. All connections from operating manifold to preventers to be all steel hose or tube a minimum of one inch in diameter.
- D. The available closing pressure shall be at least 15% in excess of that required with sufficient volume to operate (close, open, and re-close) the preventers.
- E. All connections to and from preventers to have a pressure rating equivalent to that of the BOPs.
- F. Manual controls to be installed before drilling cement plug.
- G. Valve to control flow through drill pipe to be located on rig floor.
- H. Chokes must be adjustable. Choke spool may be used between rams.

DIAGRAM 1

CONTINGENCY PLAN

BOPCO

NORTH INDIAN FLATS Section 25, T-21-S, R-28-E

Well # 2	1980' FNL	660' FEL
Well # 3	610' FNL	330' FEL
Well # 4	1980' FNL	2180' FEL
Well # 5	1980' FSL	660' FEL
Well # 6	660' FSL	990' FEL
Well # 7	990' FSL	1980' FEL
Well # 8	660' FNL	1980' FWL
Well # 9	2180' FNL	1980' FWL

Prepared For: BOPCO

Date Prepared: March 8, 2010

Prepared By: Indian Fire & Safety, A DXP Company

TABLE OF CONTENTS

H2S CONTINGENCY PLAN

1. SCOPE..... 1
2. OBJECTIVE..... 1
3. DISCUSSION OF PLAN..... 2

EMERGENCY PROCEDURES

1. EMERGENCY REACTION STEPS..... 3-5

IGNITION PROCEDURES

- i. RESPONSIBILITY..... 6
2. INSTRUCTIONS FOR IGNITING THE WELL..... 7

TRAINING PROGRAM

1. TRAINING REQUIREMENTS..... 8

EMERGENCY EQUIPMENT REQUIREMENTS..... 9-11

CHECK LISTS

1. STATUS CHECK LIST..... 12
2. PROCEDURAL CHECK LIST..... 13

EVACUATION PLAN..... 14

1. EMERGENCY ACTIONS..... 15
2. PHONE LIST – GOVERNMENT AGENCIES..... 16
3. PHONE LIST – COMPANY CONTACTS..... 16 a-b

MAPS & PLATS

1. MAP OF WELLSITE & PUBLIC WITHIN
RADIUS OF EXPOSURE..... 17

GENERAL INFORMATION

1. 100 PPM RADIUS CHART..... 18
2. 500 PPM RADIUS CHART..... 19
3. TOXIC EFFECTS OF HYDROGEN SULFIDE POISONING.... 20-21
4. USE OF SELF-CONTAINED BREATHING EQUIPMENT..... 22-23
5. RESCUE – FIRST AID FOR H2S POISONING..... 24

HYDROGEN SULFIDE CONTINGENCY PLAN

SCOPE

THIS CONTINGENCY PLAN ESTABLISHES GUIDELINES FOR THE PUBLIC, ALL COMPANY EMPLOYEES WHO'S WORK ACTIVITIES MAY INVOLVE EXPOSURE TO HYDROGEN SULFIDE (H₂S) GAS.

OBJECTIVE

1. PREVENT ANY AND ALL ACCIDENTS, AND PREVENT THE UNCONTROLLED RELEASE OF HYDROGEN SULFIDE INTO THE ATMOSPHERE.
2. PROVIDE PROPER EVACUATION PROCEDURES TO COPE WITH EMERGENCIES.
3. PROVIDE IMMEDIATE AND ADEQUATE MEDICAL ATTENTION SHOULD AN INJURY OCCUR.

H2S CONTINGENCY PLAN

DISCUSSION

GEOLOGICAL PROGNOSIS

- IMPLEMENTATION:** THIS PLAN WITH ALL DETAILS IS TO BE FULLY IMPLEMENTED BEFORE DRILLING TO PRODUCTION CASING POINT.
- EMERGENCY RESPONSE PROCEDURE:** THIS SECTION OUTLINES THE CONDITIONS AND DENOTES STEPS TO BE TAKEN IN THE EVENT OF AN EMERGENCY.
- EMERGENCY EQUIPMENT PROCEDURE:** THIS SECTION OUTLINES THE SAFETY AND EMERGENCY EQUIPMENT THAT WILL BE REQUIRED FOR THE DRILLING OF THESE WELLS.
- TRAINING PROVISIONS:** THIS SECTION OUTLINES THE TRAINING PROVISIONS THAT MUST BE ADHERED TO PRIOR TO DRILLING TO PRODUCTION CASING POINT.
- DRILLING EMERGENCY CALL LISTS:** INCLUDED ARE THE TELEPHONE NUMBERS OF ALL PERSONS TO BE CONTACTED SHOULD AN EMERGENCY EXIST.
- BRIEFING:** THIS SECTION DEALS WITH THE BRIEFING OF ALL PEOPLE INVOLVED IN THE DRILLING OPERATION.
- PUBLIC SAFETY:** PUBLIC SAFETY PERSONNEL WILL BE MADE AWARE OF THE DRILLING OF THIS WELL.
- CHECK LISTS:** STATUS CHECK LISTS AND PROCEDURAL CHECK LISTS HAVE BEEN INCLUDED TO INSURE ADHERENCE TO THE PLAN.
- GENERAL INFORMATION:** A GENERAL INFORMATION SECTION HAS BEEN INCLUDED TO SUPPLY SUPPORT INFORMATION.

H2S CONTINGENCY PLAN

EMERGENCY PROCEDURES

- A. IN THE EVENT OF ANY EVIDENCE OF H2S LEVEL ABOVE 10 PPM, TAKE THE FOLLOWING STEPS:
1. SECURE BREATHING EQUIPMENT.
 2. ORDER NON-ESSENTIAL PERSONNEL OUT OF DANGER ZONE.
 3. TAKE STEPS TO DETERMINE IF THE H2S LEVEL CAN BE CORRECTED OR SUPPRESSED AND, IF SO, PROCEED IN NORMAL OPERATION.
- B. IF UNCONTROLLABLE CONDITIONS OCCUR:
1. TAKE STEPS TO PROTECT AND/OR REMOVE ANY PUBLIC IN THE DOWN-WIND AREA FROM THE RIG – PARTIAL EVACUATION AND ISOLATION. NOTIFY NECESSARY PUBLIC SAFETY PERSONNEL AND THE BUREAU OF LAND MANAGEMENT OF THE SITUATION.
 2. REMOVE ALL PERSONNEL TO SAFE BREATHING AREA.
 3. NOTIFY PUBLIC SAFETY PERSONNEL OF THE SAFE AREA.
 4. PROCEED WITH BEST PLAN (AT THE TIME) TO REGAIN CONTROL OF THE WELL. MAINTAIN TIGHT SECURITY AND SAFETY PROCEDURES.
- C. RESPONSIBILITY:
1. DESIGNATED PERSONNEL.
 - a. SHALL BE RESPONSIBLE FOR THE TOTAL IMPLEMENTATION OF THIS PLAN.
 - b. SHALL BE IN COMPLETE COMMAND DURING ANY EMERGENCY.
 - c. SHALL DESIGNATE A BACK-UP.

EMERGENCY PROCEDURES

*(Procedures are the same for both Drilling and Tripping)

- ALL PERSONNEL:**
1. ON ALARM, DON ESCAPE UNIT AND REPORT TO UP WIND BRIEFING AREA.
 2. CHECK STATUS OF PERSONNEL (BUDDY SYSTEM).
 3. SECURE BREATHING EQUIPMENT.
 4. AWAIT ORDERS FROM SUPERVISOR.
- DRILLING FOREMAN:**
1. REPORT TO UP WIND BRIEFING AREA.
 2. DON BREATHING EQUIPMENT AND RETURN TO POINT OF RELEASE WITH TOOL PUSHER OR DRILLER (BUDDY SYSTEM).
 3. DETERMINE H₂S CONCENTRATIONS.
 4. ASSESS SITUATION AND TAKE CONTROL MEASURES.
- TOOL PUSHER:**
1. REPORT TO UP WIND BRIEFING AREA.
 2. DON BREATHING EQUIPMENT AND RETURN TO POINT OF RELEASE WITH DRILLING FOREMAN OR DRILLER (BUDDY SYSTEM).
 3. DETERMINE H₂S CONCENTRATION.
 4. ASSESS SITUATION AND TAKE CONTROL MEASURES.
- DRILLER:**
1. DON ESCAPE UNIT.
 2. CHECK MONITOR FOR POINT OF RELEASE.
 3. REPORT TO BRIEFING AREA.
 4. CHECK STATUS OF PERSONNEL (IN AN ATTEMPT TO RESCUE, USE THE BUDDY SYSTEM).
 5. ASSIGNS LEAST ESSENTIAL PERSON TO NOTIFY DRILLING FOREMAN AND TOOL PUSHER BY QUICKEST MEANS IN CASE OF THEIR ABSENCE.
 6. ASSUMES THE RESPONSIBILITIES OF THE DRILLING FORMAN AND TOOL PUSHER UNTIL THEY ARRIVE SHOULD THEY BE ABSENT.

EMERGENCY PROCEDURES

DERRICK MAN
FLOOR MAN #1
FLOOR MAN #2

1. WILL REMAIN IN BRIEFING AREA UNTIL INSTRUCTED BY SUPERVISOR.

MUD ENGINEER:

1. REPORT TO BRIEFING AREA.
2. WHEN INSTRUCTED, BEGIN CHECK OF MUD FOR PH AND H2S LEVEL. (GARETT GAS TRAIN.)

SAFETY PERSONNEL:

1. MASK UP AND CHECK STATUS OF ALL PERSONNEL AND SECURE OPERATIONS AS INSTRUCTED BY DRILLING FOREMAN AND REPORT TO BRIEFING AREA.

TAKING A KICK

WHEN TAKING A KICK DURING AN H2S EMERGENCY, ALL PERSONNEL WILL FOLLOW STANDARD BOP PROCEDURES AFTER REPORTING TO BRIEFING AREA AND MASKING UP.

OPEN-HOLE LOGGING

ALL UNNECESSARY PERSONNEL STAY OFF THE OFF FLOOR. DRILLING FOREMAN AND SAFETY PERSONNEL SHOULD MONITOR CONDITION, ADVISE STATUS AND DETERMINE NEED FOR USE OF AIR EQUIPMENT.

RUNNING CASING OR PLUGGING

FOLLOWING THE SAME "TRIPPING" PROCEDURE AS ABOVE, DRILLING FOREMAN AND SAFETY PERSONNEL SHOULD DETERMINE IF ALL PERSONNEL HAVE ACCESS TO PROTECTIVE EQUIPMENT.

H2S CONTINGENCY PLAN

IGNITION PROCEDURES

THE DECISION TO IGNITE THE WELL IS THE RESPONSIBILITY OF COMPANY FOREMAN. IN THE EVENT HE IS INCAPACITATED, IT BECOMES THE RESPONSIBILITY OF THE CONTRACT RIG TOOL PUSHER. THE DECISION SHOULD BE MADE ONLY AS A LAST RESORT AND IN A SITUATION WHERE IT IS CLEAR THAT:

1. HUMAN LIFE AND PROPERTY ARE ENDANGERED.
2. THERE IS NO HOPE CONTROLLING THE BLOWOUT UNDER THE PREVAILING CONDITIONS AT THE WELL.

NOTIFY THE DISTRICT OFFICE IF TIME PERMITS, BUT DO NOT DELAY IF HUMAN LIFE IS IN DANGER.

INITIATE FIRST PHASE OF EVACUATION PLAN.

IGNITION PROCEDURES

INSTRUCTIONS FOR IGNITING THE WELL

1. TWO PEOPLE ARE REQUIRED FOR THE ACTUAL IGNITING OPERATION. THEY MUST WEAR SELF-CONTAINED BREATHING UNITS AND HAVE SAFETY ROPE ATTACHED. ONE MAN (TOOL PUSHER OR SAFETY ENGINEER) WILL CHECK THE ATMOSPHERE FOR EXPLOSIVE GASES WITH THE EXPLOSIMETER. THE OTHER MAN (DRILLING FOREMAN) IS RESPONSIBLE FOR IGNITING THE WELL.
2. PRIMARY METHOD TO IGNITE: 25 MM FLARE GUN WITH RANGE OF APPROXIMATELY 500 FEET.
3. IGNITE UP WIND AND DO NOT APPROACH ANY CLOSER THAN IS WARRANTED.
4. SELECT THE IGNITION SITE BEST FOR PROTECTION, AND WHICH OFFERS AN EASY ESCAPE ROUTE.
5. BEFORE FIRING, CHECK FOR PRESENCE OF COMBUSTIBLE GAS.
6. AFTER LIGHTING, CONTINUE EMERGENCY ACTION AND PROCEDURE AS BEFORE.
7. ALL UNASSIGNED PERSONNEL WILL LIMIT THEIR ACTIONS TO THOSE DIRECTED BY THE DRILLING FOREMAN.

REMEMBER: AFTER WELL IS IGNITED, BURNING HYDROGEN SULFIDE WILL CONVERT TO SULFUR DIOXIDE, WHICH IS ALSO HIGHLY TOXIC. DO NOT ASSUME THE AREA IS SAFE AFTER THE WELL IS IGNITED.

H2S CONTINGENCY PLAN

TRAINING REQUIREMENTS

WHEN WORKING IN AN AREA WHERE HYDROGEN SULFIDE GAS (H₂S) MIGHT BE ENCOUNTERED, DEFINITE TRAINING REQUIREMENTS MUST BE CARRIED OUT. ALL COMPANIES WILL INSURE THAT ALL PERSONNEL AT THE WELL SITE WILL HAVE HAD ADEQUATE TRAINING IN THE FOLLOWING:

1. HAZARDS AND CHARACTERISTICS OF H₂S.
2. PHYSICAL EFFECTS OF HYDROGEN SULFIDE ON THE HUMAN BODY.
3. TOXICITY OF HYDROGEN SULFIDE AND SULFUR DIOXIDE.
4. H₂S DETECTION.
5. EMERGENCY RESCUE.
6. RESUSCITATORS.
7. FIRST AID AND ARTIFICIAL RESPIRATION.
8. EFFECTS OF H₂S ON METALS.
9. LOCATION SAFETY.

SERVICE COMPANY AND VISITING PERSONNEL

- A. EACH SERVICE COMPANY THAT WILL BE ON THIS WELL WILL BE NOTIFIED IF THE ZONE CONTAINS H₂S.
- B. EACH SERVICE COMPANY MUST PROVIDE FOR THE TRAINING AND EQUIPMENT OF THEIR EMPLOYEES BEFORE THEY ARRIVE AT THE WELL SITE.
- C. EACH SERVICE COMPANY WILL BE EXPECTED TO ATTEND A WELL SITE BRIEFING.

H2S CONTINGENCY PLAN

EMERGENCY EQUIPMENT REQUIREMENTS

1. SIGNS

- A. ONE SIGN LOCATED AT LOCATION ENTRANCE WITH THE FOLLOWING LANGUAGE:

(LEASE)
CAUTION – POTENTIAL POISON GAS
HYDROGEN SULFIDE
NO ADMITTANCE WITHOUT AUTHORIZATION

2. WIND SOCK -- WIND STREAMERS

- A. ONE 36" (IN LENGTH) WIND SOCK LOCATED AT PROTECTION CENTER, AT HEIGHT VISIBLE FROM RIG FLOOR.
- B. ONE 36" (IN LENGTH) WIND SOCK LOCATED AT HEIGHT VISIBLE FROM PIT AREAS.

3. HYDROGEN SULFIDE DETECTOR AND ALARMS

- A. H2S MONITORS WITH ALARMS WILL BE LOCATED ON THE RIG FLOOR, AT THE BELL NIPPLE, AND AT THE FLOW LINE. THESE MONITORS WILL BE SET TO ALARM AT 10 PPM WITH RED LIGHT, AND TO ALARM AT 15 PPM WITH RED LIGHT AND AUDIBLE ALARM.
- B. HAND OPERATED DETECTORS WITH TUBES.
- C. H2S MONITOR TESTER.

4. CONDITION FLAGS

- A. ONE EACH OF ORANGE, YELLOW, AND RED CONDITION FLAGS TO BE DISPLAYED TO DENOTE CONDITIONS.

GREEN – NORMAL CONDITIONS
YELLOW – POTENTIAL DANGER
RED – DANGER, H2S PRESENT

- B. CONDITION FLAG SHALL BE POSTED AT LOCATION SIGN ENTRANCE.

H2S CONTINGENCY PLAN

EMERGENCY EQUIPMENT REQUIREMENTS

5. AUXILIARY RESCUE EQUIPMENT

- A. STRETCHER
- B. 100' LENGTH OF 5/8" NYLON ROPE.

6. MUD INSPECTION DEVICES

GARRETT GAS TRAIN OR HACH TESTER FOR INSPECTION OF SULFIDE CONCENTRATION IN MUD SYSTEM.

7. FIRE EXTINGUISHER

ADEQUATE FIRE EXTINGUISHERS SHALL BE LOCATED AT STRATEGIC LOCATIONS.

8. BLOW OUT PREVENTION EQUIPMENT

THE WELL SHALL HAVE HYDRAULIC BOP EQUIPMENT FOR THE ANTICIPATED BHP OF 1500 PSI. EQUIPMENT IS TO BE TESTED ON INSTALLATION.

9. COMBUSTIBLE GAS DETECTOR

THERE SHALL BE ONE COMBUSTIBLE GAS DETECTOR ON LOCATION AT ALL TIMES.

10. BOP TESTING

BOP AND CHOKE LINE AND KILL LINE WILL BE TESTED.

11. AUDIO SYSTEM

RADIO COMMUNICATION WILL BE AVAILABLE AT THE RIG.

- A. RIG FLOOR OR TRAILER
- B. VEHICLE

12. SPECIAL CONTROL EQUIPMENT

- A. HYDRAULIC BOP EQUIPMENT WITH REMOTE CONTROL ON GROUND.
- B. ROTATING HEAD

H2S CONTINGENCY PLAN

EMERGENCY EQUIPMENT REQUIREMENTS

13. EVACUATION PLAN

EVACUATION ROUTES SHOULD BE ESTABLISHED PRIOR TO SPUDDING EACH WELL AND DISCUSSED WITH ALL RIG PERSONNEL.

14. DESIGNATED AREA

- A. PARKING AND VISITOR AREA: ALL VEHICLES ARE TO BE PARKED AT A PREDETERMINED SAFE DISTANCE FROM THE WELLHEAD. THIS WILL BE THE DESIGNATED SMOKING AREA.
- B. TWO BRIEFING AREAS ON EITHER SIDE OF THE LOCATION AT THE MAXIMUM ALLOWABLE DISTANCE FROM THE WELL BORE SO THEY OFFSET PREVAILING WINDS PERPENDICULARLY, OR AT A 45-DEGREE ANGLE IF WIND DIRECTION TENDS TO SHIFT IN THE AREA.
- C. PROTECTION CENTERS OR IF A MOVABLE TRAILER IS USED, IT SHOULD BE DEPT UPWIND OF EXISTING WINDS. WHEN WIND IS FROM THE PREVAILING DIRECTIONS, BOTH PROTECTION CENTERS SHOULD BE ACCESSIBLE.

H2S CONTINGENCY PLAN

STATUS CHECK LIST

NOTE: ALL ITEMS ON THIS LIST MUST BE COMPLETED BEFORE DRILLING TO PRODUCTION CASING POINT .

1. SIGN AT LOCATION ENTRANCE.
2. TWO (2) WIND SOCKS LOCATED AS REQUIRED.
3. TWO (2) 30-MINUTE POSITIVE PRESSURE AIR PACKS ON LOCATION FOR RIG PERSONNEL AND/OR MUD LOGGERS.
4. AIR PACK INSPECTED FOR READY USE.
5. CASCADE SYSTEM AND HOSE LINE HOOK-UP.
6. CASCADE SYSTEM FOR REFILLING AIR BOTTLES.
7. SAFE BREATHING AREAS SET UP.
8. CONDITION FLAG ON LOCATION AND READY FOR USE.
9. H2S DETECTION SYSTEM HOOKED UP.
10. H2S ALARM SYSTEM HOOKED UP AND READY.
11. OXYGEN RESUSCITATOR ON LOCATION AND TESTED FOR USE.
12. STRETCHER ON LOCATION AT SAFETY TRAILER.
13. 1 – 100' LENGTH OF NYLON ROPE ON LOCATION.
14. ALL RIG CREW AND SUPERVISORS TRAINED AS REQUIRED.
15. ALL OUTSIDE SERVICE CONTRACTORS ADVISED OF POTENTIAL H2S HAZARD ON WELL.
16. NO SMOKING SIGN POSTED.
17. HAND OPERATED H2S DETECTOR WITH TUBES ON LOCATION.

CHECKED BY: _____ DATE: _____

H2S CONTINGENCY PLAN

PROCEDURAL CHECK LIST

PERFORM EACH TOUR:

1. CHECK FIRE EXTINGUISHERS TO SEE THAT THEY HAVE THE PROPER CHARGE.
2. CHECK BREATHING EQUIPMENT TO ENSURE THAT IT HAS NOT BEEN TAMPERED WITH.
3. MAKE SURE ALL THE H2S DETECTION SYSTEM IS OPERATIVE.

PERFORM EACH WEEK:

1. CHECK EACH PIECE OF BREATHING EQUIPMENT TO MAKE SURE THAT DEMAND REGULATOR IS WORKING. THIS REQUIRES THAT THE BOTTLE BE OPENED AND THE MASK ASSEMBLY BE PUT ON TIGHT ENOUGH SO THAT WHEN YOU INHALE, YOU RECEIVE AIR.
2. BLOW OUT PREVENTER SKILLS.
3. CHECK SUPPLY PRESSURE ON BOP ACCUMULATOR STAND BY SOURCE.
4. CHECK ALL SKA-PAC UNITS FOR OPERATION: DEMAND REGULATOR, ESCAPE BOTTLE AIR VOLUMES, SUPPLY BOTTLE OF AIR VOLUME.
5. CHECK BREATHING EQUIPMENT MASK ASSEMBLY TO SEE THAT STRAPS ARE LOOSENED AND TURNED BACK, READY TO PUT ON.
6. CHECK PRESSURE ON BREATHING EQUIPMENT AIR BOTTLES TO MAKE SURE THEY ARE CHARGED TO FULL VOLUME.
7. CONFIRM PRESSURE ON ALL SUPPLY AIR BOTTLES.
8. PERFORM BREATHING EQUIPMENT DRILLS WITH ON-SITE PERSONNEL.
9. CHECK THE FOLLOWING SUPPLIES FOR AVAILABILITY.
 - A. EMERGENCY TELEPHONE LIST.
 - B. HAND OPERATED H2S DETECTORS AND TUBES.

H2S CONTINGENCY PLAN

GENERAL EVACUATION PLAN

THE DIRECT LINES OF ACTION PREPARED BY INDIAN FIRE & SAFETY, INC. TO PROTECT THE PUBLIC FROM HAZARDOUS GAS SITUATIONS ARE AS FOLLOWS:

1. WHEN THE COMPANY APPROVED SUPERVISOR (DRILLING FOREMAN, CONSULTANT, RIG PUSHER, OR DRILLER) DETERMINES THE H2S GAS CANNOT BE LIMITED TO THE WELL LOCATION AND THE PUBLIC WILL BE INVOLVED, HE WILL ACTIVATE THE EVACUATION PLAN. ESCAPE ROUTES ARE NOTED ON AREA MAP.
2. "COMPANY MAN" OR DESIGNEE WILL NOTIFY LOCAL GOVERNMENT AGENCY THAT A HAZARDOUS CONDITION EXISTS AND EVACUATION NEEDS TO BE IMPLEMENTED.
3. COMPANY SAFETY PERSONNEL THAT HAVE BEEN TRAINED IN THE USE OF H2S DETECTION EQUIPMENT AND SELF-CONTAINED BREATHING EQUIPMENT WILL MONITOR H2S CONCENTRATIONS, WIND DIRECTIONS, AND AREA OF EXPOSURE. THEY WILL DELINEATE THE OUTER PERIMETER OF THE HAZARDOUS GAS AREA. EXTENSION TO THE EVACUATION AREA WILL BE DETERMINED FROM INFORMATION GATHERED.
4. LAW ENFORCEMENT PERSONNEL (STATE POLICE, POLICE DEPT., FIRE DEPT., AND SHERIFF'S DEPT.), WILL BE CALLED TO AID IN SETTING UP AND MAINTAINING ROAD BLOCKS. ALSO, THEY WILL AID IN EVACUATION OF THE PUBLIC IF NECESSARY.

IMPORTANT: LAW ENFORCEMENT PERSONNEL WILL NOT BE ASKED TO COME INTO A CONTAMINATED AREA. THEIR ASSISTANCE WILL BE LIMITED TO UNCONTAMINATED AREAS. CONSTANT PHONE CONTACT WILL BE MAINTAINED WITH THEM.

5. AFTER THE DISCHARGE OF GAS HAS BEEN CONTROLLED, COMPANY SAFETY PERSONNEL WILL DETERMINE WHEN THE AREA IS SAFE FOR RE-ENTRY.

H2S CONTINGENCY PLAN

EMERGENCY ACTIONS

WELL BLOWOUT – IF EMERGENCY

1. EVACUATE ALL PERSONNEL IF POSSIBLE.
2. IF SOUR GAS – EVACUATE RIG PERSONNEL.
3. IF SOUR GAS – EVACUATE PUBLIC WITHIN 3000 FT RADIUS OF EXPOSURE.
4. DON SCBA AND RESCUE ANY PERSON(S) OVER COME BY H2S.
5. CALL 911 FOR EMERGENCY HELP (FIRE DEPT AND AMBULANCE) AND NOTIFY SR. DRILLING FOREMAN AND DISTRICT FOREMAN.
6. GIVE FIRST AID.

PERSON DOWN LOCATION/FACILITY

1. IF IMMEDIATELY POSSIBLE, CONTACT 911. GIVE LOCATION AND WAIT FOR CONFIRMATION.
2. DON SCBA AND RESCUE PERSON(S) “DOWN” FROM H2S.
3. REMOVE TO FRESH AIR.
4. REMOVE OUTER CLOTHING(GAS IS TRAPPED IN CLOTHING)
5. IF CPR IS NEEDED, REMEMBER THE VICTIM INHALED H2S, HE WILL ALSO EX-HALE H2S.

EMERGENCY PHONE LIST

GOVERNMENTAL AGENCIES

<u>Eddy County Sheriff's Office</u>	911
Non emergency	505-746-9888
<u>Fire Departments</u>	911
Carlsbad – Non-emergency.....	505-885-2111
<u>BLM</u>	
Carlsbad	505-361-2822
<u>State Police Department</u>	911
Non-emergency	505-437-1313
<u>City of Carlsbad</u>	
.....	505-885-2111
<u>Ambulance</u>	911
Carlsbad – Non Emergency.....	505-885-2111
<u>Hospitals</u>	
Carlsbad	505-887-4100
<u>AEROCARE</u>	806-747-8923
<u>CHEMTREC</u>	1-800-424-9300
<u>OSHA</u>	
Lubbock TX	1-800-692-4204

EMERGENCY CONTACT LIST

BOPCO, L.P.

Midland Office

432-683-2277

Steve Johnson	Division Manager	432-638-9462 cell phone
W.R. Dannels	Drilling Superintendent	432-638-9463 cell phone
Jordan Evans	Drilling Engineer	432-894-1392 cell phone
Retha Scott	HSE Representative	432-557-2785 cell phone
Carlos Cruz	Production Superintendent	432-238-9443 cell phone
Dean Clennman	Area Production Supervisor (New Mexico Area)	575-361-8074 cell phone
Buddy Jenkins	Assistant Drilling Superintendent	432-238-3295 cell phone
Tony Savoie	Waste Management & Remediation Specialist	432-556-8730 cell phone
Robert Gawlik	Sr. Environmental Safety & Health Coordinator	817-692-9366 cell phone

Indian Fire & Safety, Inc.
3317 W. County Road
505-393-3093 - office
800-530-8693 – toll free
505-392-6274 – fax

Personnel Contact List

	Cell Phone	Home Phone
Chris Spurgeon	631-3177	
Scott Dudenhoeffer	631-9753	392-4833
Sam Abney	631-9712	393-5427
Curtiss Newton	631-1255	393-3762
Joe Spurgeon	806-215-1087	806-592-0079

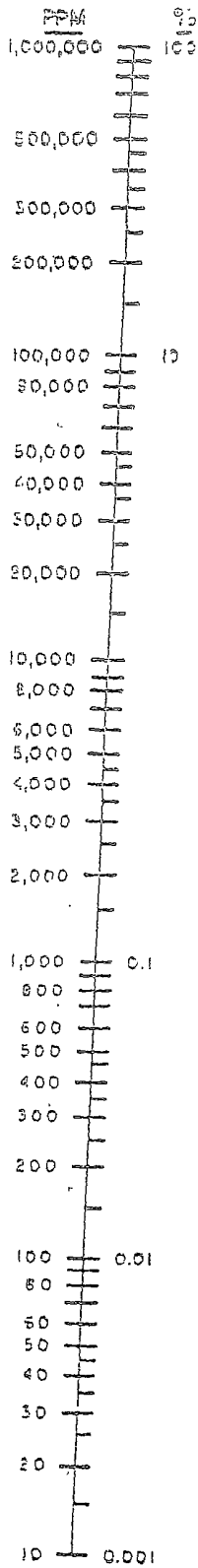

HYDROGEN SULFIDE
100 PPM EXPOSURE RADIUS

Feet

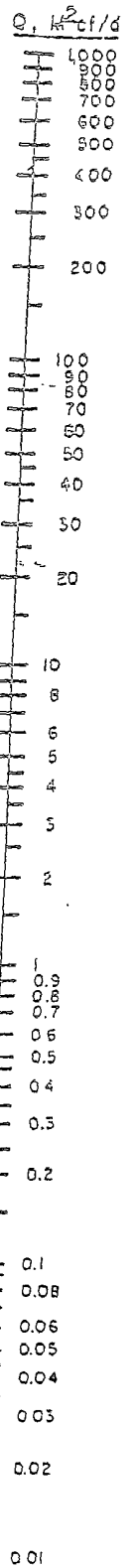
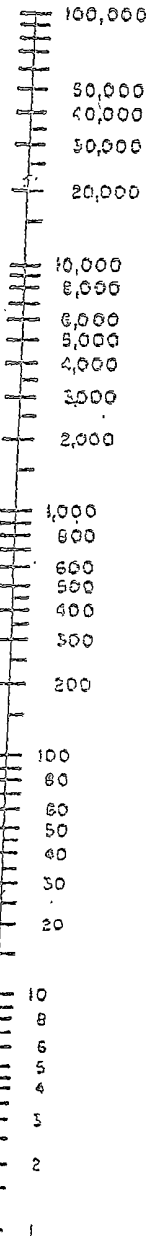

At $X = 5000$ Ft.
 $Q = 226,647$
PPM

At $X = 50$ Ft.
 $Q = 326.4$
PPM

Below 100 PPM
Rule 36 N.A.

100 PPM Radius of Exposure in Feet = X
 $X = [(1.589)(\text{Mole Fraction})(\text{Escape Rate})]^{0.6258}$
 $= [(1.589)(\text{PPM})(Q \text{ in } M^2\text{cf/d})]^{0.6258}$

$P_b 14.65$ psia $T 60$ °F

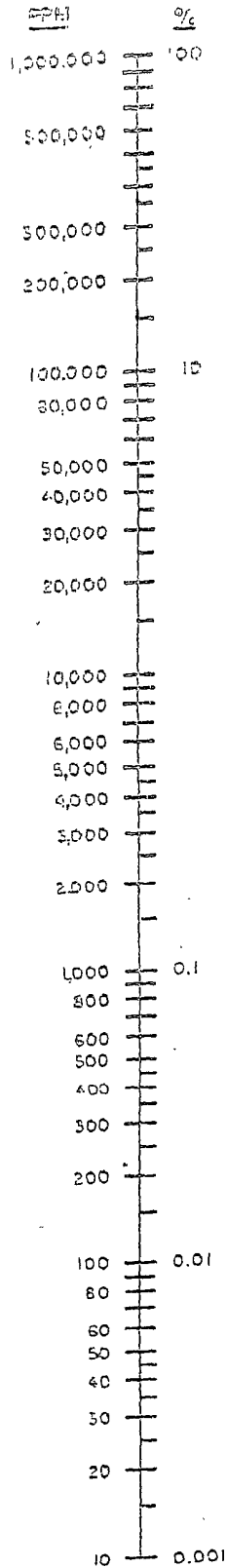

HYDROGEN SULFIDE
 500 PPM EXPOSURE RADIUS
 FEET

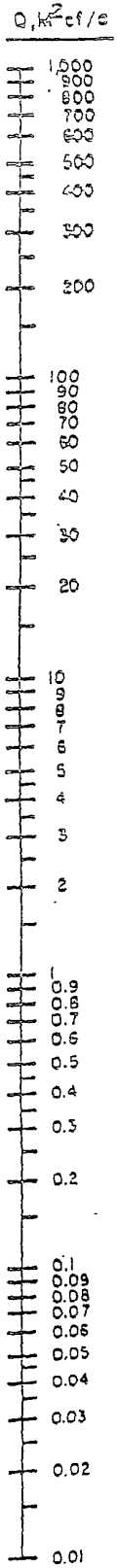
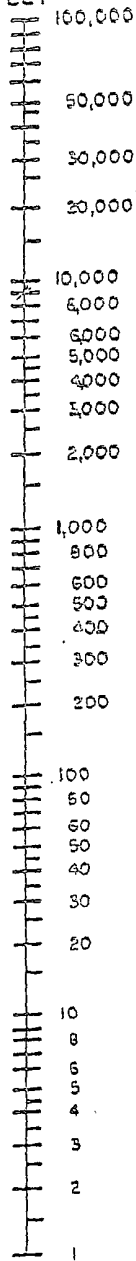

At $X = 50$ Ft.
 $Q = 1140.9$
 PPM

500 PPM Radius of Exposure in Feet = X
 $X = [(0.4546)(\text{Mole Fraction})(\text{Escape Rate})]^{0.6258}$
 $X = [(0.4546)(\text{PPM} \times 10^6)(Q \times 10^6 \text{ cu. ft.})]^{0.5258}$
 Wind velocity = 1 mph; Plume is shape of H_2S dispersion.
 Pressure base 14.65 psia, $T_b = 60^\circ F$

H2S CONTINGENCY PLAN

TOXIC EFFECTS OF HYDROGEN SULFIDE

HYDROGEN SULFIDE IS EXTREMELY TOXIC. THE ACCEPTABLE CEILING CONCENTRATION FOR EIGHT-HOUR EXPOSURE IS 10 PPM, WHICH IS .001% BY VOLUME. HYDROGEN SULFIDE IS HEAVIER THAN AIR (SPECIFIC GRAVITY – 1.192) AND COLORLESS. IT FORMS AN EXPLOSIVE MIXTURE WITH AIR BETWEEN 4.3 AND 46.0 PERCENT BY VOLUME. HYDROGEN SULFIDE IS ALMOST AS TOXIC AS HYDROGEN CYANIDE AND IS BETWEEN FIVE AND SIX TIMES MORE TOXIC THAN CARBON MONOXIDE. TOXICITY DATA FOR HYDROGEN SULFIDE AND VARIOUS OTHER GASES ARE COMPARED IN TABLE I. PHYSICAL EFFECTS AT VARIOUS HYDROGEN SULFIDE EXPOSURE LEVELS ARE SHOWN IN TABLE II.

TABLE I
TOXICITY OF VARIOUS GASES

COMMON NAME	CHEMICAL FORMULA	SPECIFIC GRAVITY (SC=1)	THRESHOLD LIMIT (1)	HAZARDOUS LIMIT (2)	LETHAL CONCENTRATION (3)
HYDROGEN CYANIDE	HCN	0.94	10 PPM	150 PPM/HR	300 PPM
HYDROGEN SULFIDE	H2S	1.18	10 PPM	250 PPM/HR	600 PPM
SULFUR DIOXIDE	SO2	2.21	5 PPM	-	1000 PPM
CHLORINE	CL2	2.45	1 PPM	4 PPM/HR	1000 PPM
CARBON MONOXIDE	CO	0.97	50 PPM	400 PPM/HR	1000 PPM
CARBON DIOXIDE	CO2	1.52	5000 PPM	5%	10%
METHANE	CH4	0.55	90,000 PPM	COMBUSTIBLE ABOVE 5% IN AIR	

- 1) THRESHOLD LIMIT – CONCENTRATION AT WHICH IT IS BELIEVED THAT ALL WORKERS MAY BE REPEATEDLY EXPOSED DAY AFTER DAY WITHOUT ADVERSE EFFECTS.
- 2) HAZARDOUS LIMIT – CONCENTRATION THAT WILL CAUSE DEATH WITH SHORT-TERM EXPOSURE.
- 3) LETHAL CONCENTRATION – CONCENTRATION THAT WILL CAUSE DEATH WITH SHORT-TERM EXPOSURE.

H2S CONTINGENCY PLAN

TOXIC EFFECTS OF HYDROGEN SULFIDE

TABLE II
PHYSICAL EFFECTS OF HYDROGEN SULFIDE

<u>PERCENT (%)</u>	<u>PPM</u>	<u>CONCENTRATION GRAINS 100 STD. FT3*</u>	<u>PHYSICAL EFFECTS</u>
0.001	<10	00.65	Obvious and unpleasant odor.
0.002	10	01.30	Safe for 8 hours of exposure.
0.010	100	06.48	Kill smell in 3 – 15 minutes. May sting eyes and throat.
0.020	200	12.96	Kills smell shortly; Stings eyes and throat.
0.050	500	32.96	Dizziness; Breathing ceases in a few minutes; Needs prompt artificial respiration.
0.070	700	45.36	Unconscious quickly; Death will result if not rescued promptly.
0.100	1000	64.30	Unconscious at once; Followed by death within minutes.

*AT 15.00 PSIA AND 60°F.

H2S CONTINGENCY PLAN

USE OF SELF-CONTAINED BREATHING EQUIPMENT

1. WRITTEN PROCEDURES SHALL BE PREPARED COVERING SAFE USE OF SCBA'S IN DANGEROUS ATMOSPHERE, WHICH MIGHT BE ENCOUNTERED IN NORMAL OPERATIONS OR IN EMERGENCIES. PERSONNEL SHALL BE FAMILIAR WITH THESE PROCEDURES AND THE AVAILABLE SCBA.
2. SCBA'S SHALL BE INSPECTED FREQUENTLY AT RANDOM TO INSURE THAT THEY ARE PROPERLY USED, CLEANED, AND MAINTAINED.
3. ANYONE WHO MAY USE THE SCBA'S SHALL BE TRAINED IN HOW TO INSURE PROPER FACE-PIECE TO FACE SEAL. THEY SHALL WEAR SCBA'S IN NORMAL AIR AND THEN WEAR THEM IN A TEST ATMOSPHERE. (NOTE: SUCH ITEMS AS FACIAL HAIR {BEARD OR SIDEBURNS} AND EYEGASSES WILL NOT ALLOW PROPER SEAL.) ANYONE THAT MAY BE REASONABLY EXPECTED TO WEAR SCBA'S SHOULD HAVE THESE ITEMS REMOVED BEFORE ENTERING A TOXIC ATMOSPHERE. A SPECIAL MASK MUST BE OBTAINED FOR ANYONE WHO MUST WEAR EYEGASSES OR CONTACT LENSES.
4. MAINTENANCE AND CARE OF SCBA'S:
 - A. A PROGRAM FOR MAINTENANCE AND CARE OF SCBA'S SHALL INCLUDE THE FOLLOWING:
 6. INSPECTION FOR DEFECTS, INCLUDING LEAK CHECKS.
 7. CLEANING AND DISINFECTING.
 8. REPAIR.
 9. STORAGE.
 - B. INSPECTION; SELF-CONTAINED BREATHING APPARATUS FOR EMERGENCY USE SHALL BE INSPECTED MONTHLY FOR THE FOLLOWING PERMANENT RECORDS KEPT OF THESE INSPECTIONS.
 1. FULLY CHARGED CYLINDERS.
 2. REGULATOR AND WARNING DEVICE OPERATION.
 3. CONDITION OF FACE PIECE AND CONNECTIONS.
 4. ELASTOMER OR RUBBER PARTS SHALL BE STRETCHED OR MASSAGED TO KEEP THEM PLIABLE AND PREVENT DETERIORATION.
 - C. ROUTINELY USED SCBA'S SHALL BE COLLECTED, CLEANED AND DISINFECTED AS FREQUENTLY AS NECESSARY TO INSURE PROPER PROTECTION IS PROVIDED. (22)

H2S CONTINGENCY PLAN

USE OF SELF-CONTAINED BREATHING EQUIPMENT

5. PERSONS ASSIGNED TASKS THAT REQUIRES USE OF SELF-CONTAINED BREATHING EQUIPMENT SHALL BE CERTIFIED PHYSICALLY FIT FOR BREATHING EQUIPMENT USAGE BY THE LOCAL COMPANY PHYSICIAN AT LEAST ANNUALLY.
6. SCBA'S SHOULD BE WORN WHEN:
 - A. ANY EMPLOYEE WORKS NEAR THE TOP OR ON TOP OF ANY TANK UNLESS TEST REVEALS LESS THAN 10 PPM OF H2S.
 - B. WHEN BREAKING OUT ANY LINE WHERE H2S CAN REASONABLY BE EXPECTED.
 - C. WHEN SAMPLING AIR IN AREAS TO DETERMINE IF TOXIC CONCENTRATIONS OF H2S EXISTS.
 - D. WHEN WORKING IN AREAS WHERE OVER 10 PPM H2S HAS BEEN DETECTED.
 - E. AT ANY TIME THERE IS A DOUBT AS TO THE H2S LEVEL IN THE AREA TO BE ENTERED.

H2S CONTINGENCY PLAN

RESCUE FIRST AID FOR H2S POISONING

DO NOT PANIC!

REMAIN CALM – THINK!

1. HOLD YOUR BREATH. (DO NOT INHALE FIRST; STOP BREATHING.)
2. PUT ON BREATHING APPARATUS.
3. REMOVE VICTIM(S) TO FRESH AIR AS QUICKLY AS POSSIBLE. (GO UP-WIND FROM SOURCE OR AT RIGHT ANGLE TO THE WIND. NOT DOWN WIND.)
4. BRIEFLY APPLY CHEST PRESSURE – ARM LIFT METHOD OF ARTIFICIAL RESPIRATION TO CLEAN THE VICTIM'S LUNGS AND TO AVOID INHALING ANY TOXIC GAS DIRECTLY FROM THE VICTIM'S LUNGS.
5. PROVIDE FOR PROMPT TRANSPORTATION TO THE HOSPITAL, AND CONTINUE GIVING ARTIFICIAL RESPIRATION IF NEEDED.
6. HOSPITAL(S) OR MEDICAL FACILITIES NEED TO BE INFORMED, BEFORE-HAND, OF THE POSSIBILITY OF H2S GAS POISONING – NO MATTER HOW REMOTE THE POSSIBILITY IS.
7. NOTIFY EMERGENCY ROOM PERSONNEL THAT THE VICTIM(S) HAS BEEN EXPOSED TO H2S GAS.

BESIDES BASIC FIRST AID, EVERYONE ON LOCATION SHOULD HAVE A GOOD WORKING KNOWLEDGE OF ARTIFICIAL RESPIRATION, AS WELL AS FIRST AID FOR EYES AND SKIN CONTACT WITH LIQUID H2S. EVERYONE NEEDS TO MASTER THESE NECESSARY SKILLS.

MULTI-POINT SURFACE USE PLAN

NAME OF WELL: North Indian Flats 25 Federal #3

LEGAL DESCRIPTION - SURFACE: 610' FNL & 330' FEL, Section 25, T21S, R28E, Eddy County, New Mexico.

POINT 1: EXISTING ROADS

- A) Proposed Well Site Location

See Exhibit "A".

- B) Existing Roads

From mile marker 42 on Highway 62-180, go west 0.6 miles to lease road. On lease road to south 4.4 miles thence east 2.0 miles to lease road, on lease road go north 2.9 miles to proposed lease road.

- C) Existing Road Maintenance or Improve Plan

See Exhibit "B"

POINT 2: NEW PLANNED ACCESS ROUTE

- A) Route Location

See Exhibit "B". The new road will be 12' wide and approximately 2913.9' long from existing lease road. The road will be constructed of watered and 6" of compacted caliche.

- B) Width

12' Wide.

- C) Maximum Grade

Not Applicable.

- D) Turnouts

As required by BLM stipulations.

- E) Culverts, Cattle Guards, and Surfacing Equipment

None.

POINT 3: LOCATION OF EXISTING WELLS

Exhibit "A" indicates existing wells within the surrounding area.

POINT 4: LOCATION OF EXSITING OR PROPOSED FACILITIES

- A) Existing facilities are located within one mile which are owned and controlled by lessee/operator:

Closest Oil/Gas production facilities are located at the Big Eddy #74 well site. The North Indian Flats 25 Federal #3 is located approximately 1361' east of the Big Eddy #74. (See Exhibit "A")

- B) New Facilities in the Event of Production

Additional production facilities will be added to the Big Eddy #74 (Section 25, T21S-R28E, NWNE) and will be used via 2-7/8" flow lines laid on top of ground. A new flow line consisting of 2-7/8" steel pipe will be laid within 50' of the centerline of the access road and existing roads which have previously been arch cleared. (See exhibit "E") Initially no power lines will be installed. A rental electric generator will be set to power pumping unit.

- C) Rehabilitation of Disturbed Areas Unnecessary for Production:

Following the construction of production facilities, those access areas required for continued production will be graded to provide drainage and minimize erosion. The areas necessary for use will be graded to blend in the surrounding topography – See Point 10.

POINT 5: LOCATION AND TYPE OF WATER SUPPLY

- A) Location and Type of Water Supply

Fresh water will be hauled from the City of Carlsbad or piped from the IMC Booster Station water well located 5.2 miles east of Carlsbad. Brine water will be hauled from I & W Brine Water Station 0.75 miles southeast of Carlsbad.

- B) Water Transportation System

Water hauled to the location will be over the existing and proposed roads or transported via temporary poly-line from the fresh water source.

POINT 6: SOURCE OF CONSTRUCTION MATERIALS

- A) Materials-

Caliche source located in Sec 5, T21S, R29E

- B) Land Ownership

Federally Owned.

- C) Materials Foreign to the Site

Caliche will be hauled from the nearest BLM approved caliche pit

D) Access Roads

2913 9' of new access roads are required. See Exhibit "B"

POINT 7: METHODS FOR HANDLING WASTE MATERIAL

A) Cuttings – Closed Loop System

Cuttings will be contained in the steel pits and will be hauled to an approved disposal facility

B) Drilling Fluids – Closed Loop System

Drilling fluids will be contained in the steel pits, frac tanks, and will be disposed of at licensed disposal facilities.

C) Produced Fluids

Water production will be contained in the steel pits

Hydrocarbon fluid or other fluids that may be produced during testing will be retained in test tanks.

D) Sewage

Current laws and regulations pertaining to the disposal of human waste will be complied with.

E) Garbage

Portable containers will be utilized for garbage disposal during the drilling of this well.

F) Cleanup of Well Site

Upon release of the drilling rig, the surface of the drilling pad will be graded to accommodate a completion rig if electric log analysis indicate potential productive zones. Reasonable cleanup will be performed prior to the final restoration of the site.

POINT 8: ANCILLARY FACILITIES

None required.

POINT 9: WELL SITE LAYOUT

A) Rig Orientation and Layout

Exhibit "D" shows the dimensions of the well pad and closed loop system, and the location of major rig components. Only minor leveling of the well site will be required. No significant cuts or fills will be necessary.

- B) Locations of closed loop system and access road

See Exhibit "D" & Exhibit "C".

- C) Lining of the Pits

No reserve pit. Closed loop system.

POINT 10: PLANS FOR RESTORATION OF THE SURFACE

- A) Reserve Pit Cleanup - Not applicable (see Point 9C above)

The pits will be fenced immediately after construction and shall be maintained until they are backfilled. Previous to backfill operations, any hydrocarbon material on the pits' surfaces shall be removed. The fluids and solids contained in the pits shall be backfilled with soil excavated from the site and soil adjacent to the reserve pits. The restored surface of the pits shall be contoured to prevent impoundment of surface water flow. Water-bars will be constructed as needed to prevent excessive erosion. Topsoil, as available, shall be placed over the restored surface in a uniform layer. The area will be seeded according to the Bureau of Land Management stipulations during the appropriate season following restoration.

- B) Restoration Plans - Production Developed

In addition, those areas not required for production will be graded to blend with the surrounding topography. Topsoil, as available, will be placed upon those areas and seeded. The portion of the site required for production will be graded to minimize erosion and provide access during inclement conditions. Following depletion and abandonment of the site, restoration procedures will be those that follow under Item C.

- C) Restoration Plans - No Production Developed

With no production developed, the entire surface disturbed by construction of the well site will be restored. The site will be contoured to blend with the surrounding topography and provide drainage of surface water. The topsoil, as available, shall be replaced in a uniform layer and seeded according to the Bureau of Land Management's stipulations.

- D) Rehabilitation's Timetable

Upon completion of drilling operations, the initial cleanup of the site will be performed as soon as weather and site conditions allow economic execution of the work.

POINT 11: OTHER INFORMATION

- A) Terrain

Relatively flat.

B) Soil

Caliche and sand

C) Vegetation

Sparse, primarily grasses and mesquite with very little grass.

D) Surface Use

Primarily grazing.

E) Surface Water

There are no ponds, lakes, streams or rivers within several miles of the wellsite

F) Water Wells

There are no water wells located within one mile of the proposed well site.

G) Residences and Buildings

None in the immediate vicinity

H) Historical Sites

None observed.

I) Archeological Resources

An archeological survey has been performed for this area and will be submitted to the Bureau of Land Management. Any location or construction conflicts will be resolved before construction begins.

J) Surface Ownership

The well site is on federal owned land.

K) Well signs will be posted at the drilling site.

L) Open Pits - None used. Closed loop system.

POINT 12: OPERATOR'S FIELD REPRESENTATIVE

(Field personnel responsible for compliance with development plan for surface use).

DRILLING

W. R. Dannels
Box 2760
Midland, Texas 79702
(432) 683-2277

PRODUCTION

Dean Clemmer
3104 East Green Street
Carlsbad, New Mexico 88220
(575) 887-7329

Carlos Cruz
Box 2760
Midland, Texas 79702
(432) 683-2277

OPERATOR CERTIFICATION

I hereby certify that I, or persons under my direct supervision have inspected the proposed drill site and access route; that I am familiar with the conditions which currently exist; that the statements made in the plan are, to the best of my knowledge, true and correct; and that the work associated with operations proposed herein will be performed by BOPCO, L.P. and its contractors and subcontractors in conformity with this plan and the terms and conditions under which it is approved. This statement is subject to the provisions of 18 U.S.C. 1001 for the filing of a false statement.

2/25/10
Date

Gary E. Gerhard
Gary E. Gerhard

PECOS DISTRICT CONDITIONS OF APPROVAL

OPERATOR'S NAME:	BOPCO LP
LEASE NO.:	LC067144
WELL NAME & NO.:	3 North Indian Flats 25 Federal
SURFACE HOLE FOOTAGE:	610' FNL & 330' FEL
BOTTOM HOLE FOOTAGE	Same
LOCATION:	Section 25, T. 21 S., R 28 E., NMPM
COUNTY:	Eddy County, New Mexico

TABLE OF CONTENTS

Standard Conditions of Approval (COA) apply to this APD. If any deviations to these standards exist or special COAs are required, the section with the deviation or requirement will be checked below.

- General Provisions**
- Permit Expiration**
- Archaeology, Paleontology, and Historical Sites**
- Noxious Weeds**
- Special Requirements**
 - Lesser Prairie-Chicken Timing Stipulations
 - Ground-level Abandoned Well Marker
 - Hydrology – Berming and avoidance of Old Indian Draw**
- Construction**
 - Notification
 - V-Door Direction – Not Stipulated
 - Topsoil
 - Closed Loop System
 - Federal Mineral Material Pits
 - Well Pads
 - Roads
- Road Section Diagram**
- Drilling**
 - H2S Requirements-Onshore Order #6
 - Medium Cave/Karst
 - Logging Requirements
- Production (Post Drilling)**
 - Well Structures & Facilities
 - Pipelines
 - Electric Lines
- Interim Reclamation**
- Final Abandonment & Reclamation**

I. GENERAL PROVISIONS

The approval of the Application For Permit To Drill (APD) is in compliance with all applicable laws and regulations: 43 Code of Federal Regulations 3160, the lease terms, Onshore Oil and Gas Orders, Notices To Lessees, New Mexico Oil Conservation Division (NMOCD) Rules, National Historical Preservation Act As Amended, and instructions and orders of the Authorized Officer. Any request for a variance shall be submitted to the Authorized Officer on Form 3160-5, Sundry Notices and Report on Wells.

I. PERMIT EXPIRATION

If the permit terminates prior to drilling and drilling cannot be commenced within 60 days after expiration, an operator is required to submit Form 3160-5, Sundry Notices and Reports on Wells, requesting surface reclamation requirements for any surface disturbance. However, if the operator will be able to initiate drilling within 60 days after the expiration of the permit, the operator must have set the conductor pipe in order to allow for an extension of 60 days beyond the expiration date of the APD. (Filing of a Sundry Notice is required for this 60 day extension.)

II. ARCHAEOLOGICAL, PALEONTOLOGY & HISTORICAL SITES

Any cultural and/or paleontological resource discovered by the operator or by any person working on the operator's behalf shall immediately report such findings to the Authorized Officer. The operator is fully accountable for the actions of their contractors and subcontractors. The operator shall suspend all operations in the immediate area of such discovery until written authorization to proceed is issued by the Authorized Officer. An evaluation of the discovery shall be made by the Authorized Officer to determine the appropriate actions that shall be required to prevent the loss of significant cultural or scientific values of the discovery. The operator shall be held responsible for the cost of the proper mitigation measures that the Authorized Officer assesses after consultation with the operator on the evaluation and decisions of the discovery. Any unauthorized collection or disturbance of cultural or paleontological resources may result in a shutdown order by the Authorized Officer.

III. NOXIOUS WEEDS

The operator shall be held responsible if noxious weeds become established within the areas of operations. Weed control shall be required on the disturbed land where noxious weeds exist, which includes the roads, pads, associated pipeline corridor, and adjacent land affected by the establishment of weeds due to this action. The operator shall consult with the Authorized Officer for acceptable weed control methods, which include following EPA and BLM requirements and policies.

IV. SPECIAL REQUIREMENT(S)

Archaeological monitor to be present during construction.

Timing Limitation Stipulation / Condition of Approval for lesser prairie-chicken:

Oil and gas activities including 3-D geophysical exploration, and drilling will not be allowed in lesser prairie-chicken habitat during the period from March 1st through June 15th annually. During that period, other activities that produce noise or involve human activity, such as the maintenance of oil and gas facilities, pipeline, road, and well pad construction, will be allowed except between 3:00 am and 9:00 am. The 3:00 am to 9:00 am restriction will not apply to normal, around-the-clock operations, such as venting, flaring, or pumping, which do not require a human presence during this period. Additionally, no new drilling will be allowed within up to 200 meters of leks known at the time of permitting. Normal vehicle use on existing roads will not be restricted. Exhaust noise from pump jack engines must be muffled or otherwise controlled so as not to exceed 75 db measured at 30 feet from the source of the noise.

Ground-level Abandoned Well Marker to avoid raptor perching: Upon the plugging and subsequent abandonment of the well, the well marker will be installed at ground level on a plate containing the pertinent information for the plugged well.

Porto-johns and trash containers will be on-location during-fracturing-operations or any other crew-intensive operations.

- Surface disturbance will not be allowed within 100 feet of Old Indian Draw.
- The entire well pad will be bermed to prevent oil, salt, and other chemical contaminants from leaving the well pad.
- No water flow from the uphill side(s) of the pad shall be allowed to enter the well pad. The berm shall be maintained through the life of the well and after interim reclamation has been completed.

Tank Battery COAs Only:

- Tank battery locations will be lined and bermed. A 20 mil permanent liner will be installed with a 4 oz. felt backing to prevent tears or punctures. Tank battery berms must be large enough to contain 1 ½ times the content of the largest tank.
- Automatic shut off, check valves, or similar systems will be installed for tanks to minimize the effects of catastrophic line failures used in production or drilling.

V. CONSTRUCTION

A. NOTIFICATION

The BLM shall administer compliance and monitor construction of the access road and well pad. Notify the Carlsbad Field Office at (575) 234-5972 at least 3 working days prior to commencing construction of the access road and/or well pad.

When construction operations are being conducted on this well, the operator shall have the approved APD and Conditions of Approval (COA) on the well site and they shall be made available upon request by the Authorized Officer.

B. V-DOOR DIRECTION: Not Stipulated

C. TOPSOIL

The operator shall stockpile the topsoil in a low profile manner in order to prevent wind/water erosion of the topsoil. The topsoil to be stripped is approximately 12 inches in depth. The topsoil will be used for interim and final reclamation.

Operator shall separate top-soil from any other materials placed on location as a result of “flipping” surface materials to expose and/or extract caliche from underneath the well-pad location.

D. CLOSED LOOP SYSTEM

Tanks are required for drilling operations: No Pits.

The operator shall properly dispose of drilling contents at an authorized disposal site.

E. FEDERAL MINERAL MATERIALS PIT

Payment shall be made to the BLM prior to removal of any federal mineral materials. Call the Carlsbad Field Office at (575) 234-5972.

F. WELL PAD SURFACING

Surfacing of the well pad is not required.

If the operator elects to surface the well pad, the surfacing material may be required to be removed at the time of reclamation.

The well pad shall be constructed in a manner which creates the smallest possible surface disturbance, consistent with safety and operational needs.

G. ON LEASE ACCESS ROADS

Road Width

The access road shall have a driving surface that creates the smallest possible surface disturbance and does not exceed fourteen (14) feet in width. The maximum width of surface disturbance, when constructing the access road, shall not exceed thirty (30) feet.

Surfacing

Surfacing material is not required on the new access road driving surface. If the operator elects to surface the new access road or pad, the surfacing material may be required to be removed at the time of reclamation.

Where possible, no improvements should be made on the unsurfaced access road other than to remove vegetation as necessary, road irregularities, safety issues, or to fill low areas that may sustain standing water.

The Authorized Officer reserves the right to require surfacing of any portion of the access road at any time deemed necessary. Surfacing may be required in the event the road deteriorates, erodes, road traffic increases, or it is determined to be beneficial for future field development. The surfacing depth and type of material will be determined at the time of notification.

Crowning

Crowning shall be done on the access road driving surface. The road crown shall have a grade of approximately 2% (i.e., a 1" crown on a 14' wide road). The road shall conform to Figure 1; cross section and plans for typical road construction.

Ditching

Ditching shall be required on both sides of the road.

Turnouts

Vehicle turnouts shall be constructed on the road. Turnouts shall be intervisible with interval spacing distance less than 1000 feet. Turnouts shall be constructed on all blind curves. Turnouts shall conform to the following diagram:

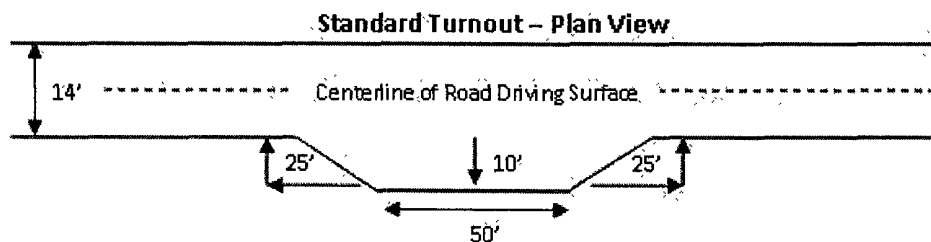

Drainage

Drainage control systems shall be constructed on the entire length of road (e.g. ditches, sidehill outsloping and insloping, lead-off ditches, culvert installation, and low water crossings).

A typical lead-off ditch has a minimum depth of 1 foot below and a berm of 6 inches above natural ground level. The berm shall be on the down-slope side of the lead-off ditch.

Cross Section of a Typical Lead-off Ditch

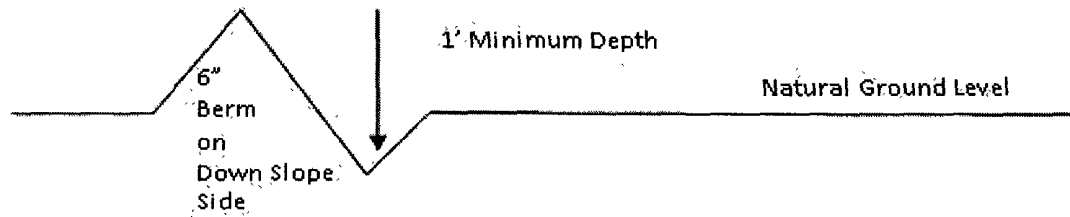

All lead-off ditches shall be graded to drain water with a 1 percent minimum to 3 percent maximum ditch slope. The spacing interval are variable for lead-off ditches and shall be determined according to the formula for spacing intervals of lead-off ditches, but may be amended depending upon existing soil types and centerline road slope (in %);

Formula for Spacing Interval of Lead-off Ditches

Example - On a 4% road slope that is 400 feet long, the water flow shall drain water into a lead-off ditch. Spacing interval shall be determined by the following formula:

$$400 \text{ foot road with } 4\% \text{ road slope: } \frac{400'}{4\%} + 100' = 200' \text{ lead-off ditch interval}$$

Culvert Installations

Appropriately sized culvert(s) shall be installed at the deep waterway channel flow crossing.

Cattleguards

An appropriately sized cattleguard(s) sufficient to carry out the project shall be installed and maintained at fence crossing(s).

Any existing cattleguard(s) on the access road shall be repaired or replaced if they are damaged or have deteriorated beyond practical use. The operator shall be responsible for the condition of the existing cattleguard(s) that are in place and are utilized during lease operations.

A gate shall be constructed and fastened securely to H-braces.

Fence Requirement

Where entry is required across a fence line, the fence shall be braced and tied off on both sides of the passageway prior to cutting.

The operator shall notify the private surface landowner or the grazing allotment holder prior to crossing any fence(s).

Public Access

Public access on this road shall not be restricted by the operator without specific written approval granted by the Authorized Officer.

Figure 1 – Cross Sections and Plans For Typical Road Sections

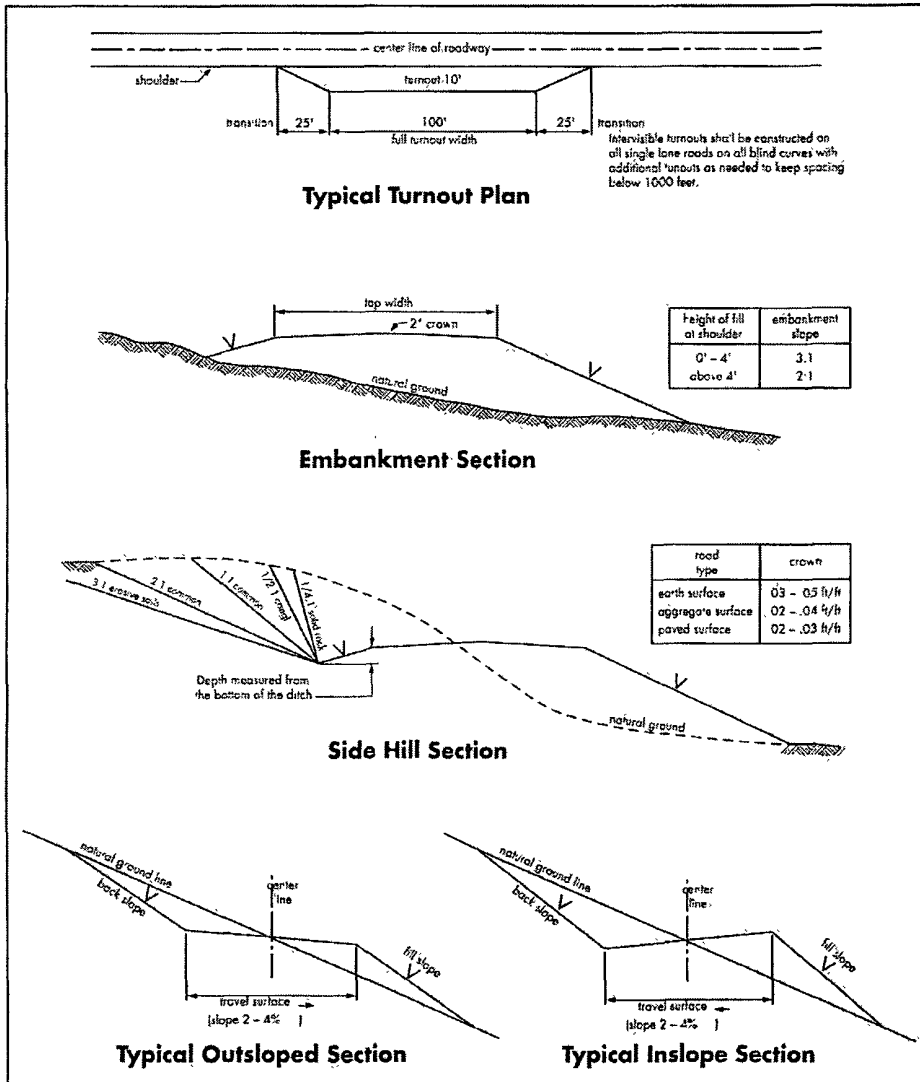

VI. DRILLING

A. DRILLING OPERATIONS REQUIREMENTS

The BLM is to be notified a minimum of 4 hours in advance for a representative to witness:

- a. Spudding well
- b. Setting and/or Cementing of all casing strings
- c. BOPE tests

Eddy County

Call the Carlsbad Field Office, 620 East Greene St., Carlsbad, NM 88220,
(575) 361-2822

1. A Hydrogen Sulfide (H₂S) Drilling Plan should be activated 500 feet prior to drilling into the Delaware formation. **As a result, the Hydrogen Sulfide area must meet Onshore Order 6 requirements, which includes equipment and personnel/public protection items. If Hydrogen Sulfide is encountered, please provide measured values and formations to the BLM.**
2. Unless the production casing has been run and cemented or the well has been properly plugged, the drilling rig shall not be removed from over the hole without prior approval.
3. **The record of the drilling rate along with the CAL/GR/N well log run from TD to surface will be submitted to the BLM office as well as all other logs run on the borehole 30 days from completion. If available, a digital copy of the logs is to be submitted in addition to the paper copies. The Rustler top and top and bottom of Salt are to be recorded on the Completion Report.**

B. CASING

Changes to the approved APD casing and cement program require submitting a sundry and receiving approval prior to work. Failure to obtain approval prior to work will result in an Incident of Non-Compliance being issued.

Centralizers required on surface casing per Onshore Order 2.III.B.1.f.

Wait on cement (WOC) time for a primary cement job will be a minimum 18 hours for a water basin, 24 hours in the potash area, or 500 pounds compressive strength, whichever is greater for all casing strings. Provide compressive strengths including hours to reach required 500 pounds compressive strength prior to cementing each casing string. See individual casing strings for details regarding lead cement slurry requirements.

No pea gravel permitted for remedial or fall back remedial without prior authorization from the BLM engineer.

Medium Cave/Karst

Possible lost circulation in the Delaware and Bone Spring Formation.

1. The 8-5/8 inch surface casing shall be set at **approximately 443 feet (a minimum of 25 feet into the Rustler Anhydrite and above the salt)** and cemented to the surface. **If salt is encountered the casing must be set 25 feet above the salt.**
 - a. If cement does not circulate to the surface, the appropriate BLM office shall be notified and a temperature survey utilizing an electronic type temperature survey with a surface log readout will be used or a cement bond log shall be run to verify the top of the cement. Temperature survey will be run a minimum of six hours after pumping cement and ideally between 8-10 hours after completing the cement job.
 - b. **Wait on cement (WOC) time for a primary cement job is to include the lead cement slurry.**
 - c. Wait on cement (WOC) time for a remedial job will be a minimum of 4 hours after bringing cement to surface or 500 pounds compressive strength, whichever is greater.
 - d. If cement falls back, remedial cementing will be done prior to drilling out that string.
2. The minimum required fill of cement behind the 5-1/2 inch production casing is:
 - Cement to surface due to cave/karst.** If cement does not circulate, contact the appropriate BLM office. **Additional cement will be required to bring the cement to surface.**
3. If hardband drill pipe is rotated inside casing, returns will be monitored for metal. If metal is found in samples, drill pipe will be pulled and rubber protectors which have a larger diameter than the tool joints of the drill pipe will be installed prior to continuing drilling operations.

C. PRESSURE CONTROL

1. All blowout preventer (BOP) and related equipment (BOPE) shall comply with well control requirements as described in Onshore Oil and Gas Order No. 2 and API RP 53 Sec. 17.

2. Minimum working pressure of the blowout preventer (BOP) and related equipment (BOPE) required for drilling below the surface casing shoe shall be **2000 (2M)** psi.
3. The appropriate BLM office shall be notified a minimum of 4 hours in advance for a representative to witness the tests.
 - a. Casing cut-off and BOP installation will not be initiated until the cement has had a minimum of 8 hours setup time for a water basin. The casing shall remain stationary and under pressure for at least eight hours after the operator places the cement. In the potash area, the minimum time is 12 hours and the casing shall remain stationary and under pressure during this time period. Casing shall be under pressure if the operator uses some acceptable means of holding pressure or if the operator employs one or more float valves to hold the cement in place. Testing the BOP/BOPE against a plug can commence after meeting the above conditions plus the BOP installation time.
 - b. The tests shall be done by an independent service company utilizing a test plug.
 - c. The results of the test shall be reported to the appropriate BLM office.
 - d. All tests are required to be recorded on a calibrated test chart. **A copy of the BOP/BOPE test chart and a copy of independent service company test will be submitted to the appropriate BLM office.**
 - e. The BOP/BOPE test shall include a low pressure test from 250 to 300 psi. The test will be held for a minimum of 10 minutes if test is done with a test plug and 30 minutes without a test plug.

D. DRILL STEM TEST

If drill stem tests are performed, Onshore Order 2.III.D shall be followed.

CRW 040110

VII. PRODUCTION (POST DRILLING)

A. WELL STRUCTURES & FACILITIES

Placement of Production Facilities

Production facilities should be placed on the well pad to allow for maximum interim recontouring and revegetation of the well location.

Containment Structures

The containment structure shall be constructed to hold the capacity of the entire contents of the largest tank, plus 24 hour production, unless more stringent protective requirements are deemed necessary by the Authorized Officer.

Painting Requirement

All above-ground structures including meter housing that are not subject to safety requirements shall be painted a flat non-reflective paint color Shale Green, Munsell Soil Color Chart # 5Y 4/2

B. PIPELINES – 2 7/8” Steel surface

STANDARD STIPULATIONS FOR SURFACE INSTALLED PIPELINES

A copy of the grant and attachments, including stipulations, survey plat and/or map, will be on location during construction. BLM personnel may request to you a copy of your permit during construction to ensure compliance with all stipulations.

Holder agrees to comply with the following stipulations to the satisfaction of the Authorized Officer:

1. The holder shall indemnify the United States against any liability for damage to life or property arising from the occupancy or use of public lands under this grant.
2. The holder shall comply with all applicable Federal laws and regulations existing or hereafter enacted or promulgated. In any event, the holder shall comply with the Toxic Substances Control Act of 1976 as amended, 15 USC 2601 *et seq.* (1982) with regards to any toxic substances that are used, generated by or stored on the right-of-way or on facilities authorized under this right-of-way grant. (See 40 CFR, Part 702-799 and especially, provisions on polychlorinated biphenyls, 40 CFR 761.1-761.193.) Additionally, any release of toxic substances (leaks, spills, etc.) in excess of the reportable quantity established by 40 CFR, Part 117 shall be reported as required by the Comprehensive Environmental Response, Compensation, and Liability Act, section 102b. A copy of any report required or requested by any Federal agency or State government as a result of a reportable release or spill of any toxic substances shall be furnished to the authorized officer concurrent with the filing of the reports to the involved Federal agency or State government.

3. The holder agrees to indemnify the United States against any liability arising from the release of any hazardous substance or hazardous waste (as these terms are defined in the Comprehensive Environmental Response, Compensation and Liability Act of 1980, 42 U.S.C. 9601, et seq. or the Resource Conservation and Recovery Act, 42 U.S.C. 6901, et seq.) on the Right-of-Way (unless the release or threatened release is wholly unrelated to activity of the Right-of-Way holder's activity on the Right-of-Way), or resulting from the activity of the Right-of-Way holder on the Right-of-Way. This agreement applies without regard to whether a release is caused by the holder, its agent, or unrelated third parties.

4. The holder shall be liable for damage or injury to the United States to the extent provided by 43 CFR Sec. 2883.1-4. The holder shall be held to a standard of strict liability for damage or injury to the United States resulting from pipe rupture, fire, or spills caused or substantially aggravated by any of the following within the right-of-way or permit area:

- a. Activities of the holder including, but not limited to construction, operation, maintenance, and termination of the facility.
- b. Activities of other parties including, but not limited to:
 - (1) Land clearing.
 - (2) Earth-disturbing and earth-moving work.
 - (3) Blasting.
 - (4) Vandalism and sabotage.
- c. Acts of God.

The maximum limitation for such strict liability damages shall not exceed one million dollars (\$1,000,000) for any one event, and any liability in excess of such amount shall be determined by the ordinary rules of negligence of the jurisdiction in which the damage or injury occurred.

This section shall not impose strict liability for damage or injury resulting primarily from an act of war or from the negligent acts or omissions of the United States.

5. If, during any phase of the construction, operation, maintenance, or termination of the pipeline, any oil, salt water, or other pollutant should be discharged from the pipeline system, impacting Federal lands, the control and total removal, disposal, and cleaning up of such oil, salt water, or other pollutant, wherever found, shall be the responsibility of the holder, regardless of fault. Upon failure of the holder to control, dispose of, or clean up such discharge on or affecting Federal lands, or to repair all damages resulting therefrom, on the Federal lands, the Authorized Officer may take such measures as he deems necessary to control and clean up the discharge and restore the area, including, where appropriate, the aquatic environment and fish and wildlife habitats, at the full expense of the holder. Such action by the Authorized Officer shall not relieve the holder

of any responsibility as provided herein.

6. All construction and maintenance activity will be confined to the authorized right-of-way width of 25 feet.

7. No blading or clearing of any vegetation will be allowed unless approved in writing by the Authorized Officer.

8. The holder shall install the pipeline on the surface in such a manner that will minimize suspension of the pipeline across low areas in the terrain. In hummocky or dune areas, the pipeline will be "snaked" around hummocks and dunes rather than suspended across these features.

9. The pipeline shall be buried with a minimum of 24 inches under all roads, "two-tracks," and trails. Burial of the pipe will continue for 20 feet on each side of each crossing. The condition of the road, upon completion of construction, shall be returned to at least its former state with no bumps or dips remaining in the road surface.

10. The holder shall minimize disturbance to existing fences and other improvements on public lands. The holder is required to promptly repair improvements to at least their former state. Functional use of these improvements will be maintained at all times. The holder will contact the owner of any improvements prior to disturbing them. When necessary to pass through a fence line, the fence shall be braced on both sides of the passageway prior to cutting of the fence. No permanent gates will be allowed unless approved by the Authorized Officer.

11. In those areas where erosion control structures are required to stabilize soil conditions, the holder will install such structures as are suitable for the specific soil conditions being encountered and which are in accordance with sound resource management practices.

12. Excluding the pipe, all above-ground structures not subject to safety requirement shall be painted by the holder to blend with the natural color of the landscape. The paint used shall be a color which simulates "Standard Environmental Colors" – **Shale Green**, Munsell Soil Color No. 5Y 4/2; designated by the Rocky Mountain Five State Interagency Committee.

13. The pipeline will be identified by signs at the point of origin and completion of the right-of-way and at all road crossings. At a minimum, signs will state the holder's name, BLM serial number, and the product being transported. Signs will be maintained in a legible condition for the life of the pipeline.

14. The holder shall not use the pipeline route as a road for purposes other than routine maintenance as determined necessary by the Authorized Officer in consultation with the holder. The holder will take whatever steps are necessary to ensure that the pipeline route is not used as a roadway.

15. Any cultural and/or paleontological resource (historic or prehistoric site or object) discovered by the holder, or any person working on his behalf, on public or Federal land shall be immediately reported to the authorized officer. Holder shall suspend all operations in the immediate area of such discovery until written authorization to proceed is issued by the authorized officer. An evaluation of the discovery will be made by the authorized officer to determine appropriate cultural or scientific values. The holder will be responsible for the cost of evaluation and any decision as to proper mitigation measures will be made by the authorized officer after consulting with the holder.

Surface Pipeline COAs:

- A leak detection plan will be submitted to the BLM Carlsbad Field Office for approval prior to pipeline installation. The method could incorporate gauges to detect pressure drops, siting valves and lines so they can be visually inspected periodically or installing electronic sensors to alarm when a leak is present. The leak detection plan will incorporate an automatic shut off system that will be installed for proposed pipelines to minimize the effects of an undesirable event.

C. ELECTRIC LINES – Not requested in APD

VIII. INTERIM RECLAMATION

During the life of the development, all disturbed areas not needed for active support of production operations should undergo interim reclamation in order to minimize the environmental impacts of development on other resources and uses.

Within six (6) months of well completion, operators should work with BLM surface management specialists (Jim Amos: 575-234-5909) to devise the best strategies to reduce the size of the location. Interim reclamation should allow for remedial well operations, as well as safe and efficient removal of oil and gas.

During reclamation, the removal of caliche is important to increasing the success of revegetating the site. Removed caliche that is free of contaminants may be used for road repairs, fire walls or for building other roads and locations. In order to operate the well or complete workover operations, it may be necessary to drive, park and operate on restored interim vegetation within the previously disturbed area. Disturbing revegetated areas for production or workover operations will be allowed. If there is significant disturbance and loss of vegetation, the area will need to be revegetated. Communicate with the appropriate BLM office for any exceptions/exemptions if needed.

All disturbed areas after they have been satisfactorily prepared need to be reseeded with the seed mixture provided below.

Upon completion of interim reclamation, the operator shall submit a Sundry Notices and Reports on Wells, Subsequent Report of Reclamation (Form 3160-5).

X. FINAL ABANDONMENT & RECLAMATION

At final abandonment, well locations, production facilities, and access roads must undergo "final" reclamation so that the character and productivity of the land are restored.

Earthwork for final reclamation must be completed within six (6) months of well plugging. All pads, pits, facility locations and roads must be reclaimed to a satisfactory revegetated, safe, and stable condition, unless an agreement is made with the landowner or BLM to keep the road and/or pad intact.

After all disturbed areas have been satisfactorily prepared; these areas need to be revegetated with the seed mixture provided below. Seeding should be accomplished by drilling on the contour whenever practical or by other approved methods. Seeding may need to be repeated until revegetation is successful, as determined by the BLM.

Operators shall contact a BLM surface protection specialist prior to surface abandonment operations for site specific objectives (Jim Amos: 575-234-5909).

Ground-level Abandoned Well Marker to avoid raptor perching: Upon the plugging and subsequent abandonment of the well, the well marker will be installed at ground level on a plate containing the pertinent information for the plugged well.

Seed Mixture for LPC Sand/Shinnery Sites

The holder shall seed all disturbed areas with the seed mixture listed below. The seed mixture shall be planted in the amounts specified in pounds of pure live seed (PLS)* per acre. There shall be no primary or secondary noxious weeds in the seed mixture. Seed will be tested and the viability testing of seed will be done in accordance with State law(s) and within nine (9) months prior to purchase. Commercial seed will be either certified or registered seed. The seed container will be tagged in accordance with State law(s) and available for inspection by the authorized officer.

Seed will be planted using a drill equipped with a depth regulator to ensure proper depth of planting where drilling is possible. The seed mixture will be evenly and uniformly planted over the disturbed area (smaller/heavier seeds have a tendency to drop the bottom of the drill and are planted first). The holder shall take appropriate measures to ensure this does not occur. Where drilling is not possible, seed will be broadcast and the area shall be raked or chained to cover the seed. When broadcasting the seed, the pounds per acre are to be doubled. The seeding will be repeated until a satisfactory stand is established as determined by the authorized officer. Evaluation of growth will not be made before completion of at least one full growing season after seeding.

Species to be planted in pounds of pure live seed* per acre:

<u>Species</u>	<u>lb/acre</u>
Plains Bristlegrass	5lbs/A
Sand Bluestem	5lbs/A
Little Bluestem	3lbs/A
Big Bluestem	6lbs/A
Plains Coreopsis	2lbs/A
Sand Dropseed	1lbs/A

**Four-winged Saltbush 5lbs/A

* This can be used around well pads and other areas where caliche cannot be removed.

*Pounds of pure live seed:

Pounds of seed x percent purity x percent germination = pounds pure live seed