

B.L.M. Oil Cons. Div-Dist. 2  
1301 W. Grand Avenue  
Artesia, NM 88210

RECEIVED  
OCD - ARTESIA

UNITED STATES  
DEPARTMENT OF THE INTERIOR  
BUREAU OF LAND MANAGEMENT

APPLICATION FOR PERMIT TO DRILL OR REENTER

0  
OMB No. 1004-0136  
Expires November 30, 2000

5. Lease Serial No.  
**NM-10588**

6. If Indian, Allottee or Tribe Name  
**Not Applicable**

7. If Unit or CA Agreement, Name and No.  
**Not Applicable**

8. Lease Name and Well No. *12306*  
**George "QJ" Federal #11**

9. API Well No.  
**30-005-63444**

10. Field and Pool, or Exploratory  
*Cottonwood Ranch, Penn. Gas*  
**Wildcat Precambrian**

11. Sec., T., R., M., or Blk, and Survey or Area  
**Section 26, T6S-R25E**

12. County or Parish  
**Chaves County**

13. State  
**NM**

1a. Type of Work:  DRILL  REENTER

b. Type of Well:  Oil Well  Gas Well  Other  Single Zone  Multiple Zone

2. Name of Operator  
**Yates Petroleum Corporation** *95575*

3A. Address **105 South Fourth Street  
Artesia, New Mexico 88210**

3b. Phone No. (include area code)  
**(505) 748-1471**

4. Location of Well (Report location clearly and in accordance with any State requirements. \*)  
At surface **1980' FNL and 4660' FWL, Unit Letter F**  
At proposed prod. Zone **same as above**

14. Distance in miles and direction from nearest town or post office\*  
**Approximately 35 miles northeast of Roswell, New Mexico**

15. Distance from proposed\* location to nearest property or lease line, ft. (Also to nearest drig. unit line, if any)

16. No. of Acres in lease  
**1000**

17. Spacing Unit dedicated to this well  
**320 W/2**

18. Distance from proposed location\* to nearest well, drilling, completed, applied for, on this lease, ft.

19. Proposed Depth  
**5285'**

20. BLM/BIA Bond No. on file  
**NM-2811**

21. Elevations (Show whether DF, KDB, RT, GL, etc.)  
**3767' GL**

22. Approximate date work will start\*  
**ASAP**

23. Estimated duration  
**30 Days**

24. Attachments

The following, completed in accordance with the requirements of Onshore Oil and Gas Order No. 1, shall be attached to this form:

- Well plat certified by a registered surveyor.
- A Drilling Plan.
- A Surface Use Plan (if the location is on National Forest System Lands, the SUPO shall be filed with the appropriate Forest Service Office.
- Bond to cover the operations unless covered by an existing bond on file (see Item 20 above).
- Operator certification.
- Such other site specific information and/or plans as may be required by the authorized office.

25. Signature *Pat Perez* Name (Printed/Typed) **Pat Perez** Date **10/5/01**

Title: **Regulatory Agent**

Approved by (Signature) */s/LARRY D. BRAY* Name (Printed/Typed) **/s/LARRY D. BRAY** Date **JAN 24 2002**

Title Office **ROSWELL FIELD OFFICE**

Application approval does not warrant or certify that the applicant holds legal or equitable title to those rights in the subject lease which would entitle the applicant to conduct operations thereon.  
Conditions of approval, if any, are attached.

Title 18 U.S.C. Section 1001 and Title 43 U.S.C. Section 1212, make it a crime for any person knowingly and willfully to make to any department or agency of the United States any false, fictitious or fraudulent statements or representations as to any matter within its jurisdiction.

\*(Instructions on reverse)

**ROSWELL CONTROLLED WATER BASIN**

APPROVAL SUBJECT TO  
GENERAL REQUIREMENTS AND  
SPECIAL REGULATIONS

BUREAU OF LAND MGMT  
ROSWELL OFFICE

2001 OCT -9 PM 3:38

RECEIVED

DISTRICT I  
1825 N. French Dr., Hobbs, NM 88240

DISTRICT II  
811 South First, Artesia, NM 88210

DISTRICT III  
1800 Rio Brazos Rd., Artec, NM 87410

DISTRICT IV  
2049 South Pacheco, Santa Fe, NM 87506

State of New Mexico  
Energy, Minerals and Natural Resources Department

Form C-102  
Revised March 17, 1999  
Instruction on back  
Submit to Appropriate District Office  
State Lease - 4 Copies  
Fee Lease - 3 Copies

OIL CONSERVATION DIVISION  
P.O. Box 2088  
Santa Fe, New Mexico 87504-2088

AMENDED REPORT

WELL LOCATION AND ACREAGE DEDICATION PLAT

API Number	Pool Code	Pool Name
		Wildcat Precambrian
Property Code	Property Name	Well Number
	GEORGE "QJ" FEDERAL	11
OGRID No.	Operator Name	Elevation
025575	YATES PETROLEUM CORPORATION	3766

Surface Location

UL or lot No.	Section	Township	Range	Lot Idn.	Feet from the	North/South line	Feet from the	East/West line	County
F	26	6S	25E		1980	NORTH	1980	WEST	CHAVES

Bottom Hole Location If Different From Surface

UL or lot No.	Section	Township	Range	Lot Idn.	Feet from the	North/South line	Feet from the	East/West line	County
Dedicated Acres	Joint or Infill	Consolidation Code	Order No.						
320.00									

NO ALLOWABLE WILL BE ASSIGNED TO THIS COMPLETION UNTIL ALL INTERESTS HAVE BEEN CONSOLIDATED OR A NON-STANDARD UNIT HAS BEEN APPROVED BY THE DIVISION

	<p><b>OPERATOR CERTIFICATION</b></p> <p>I hereby certify the the information contained herein is true and complete to the best of my knowledge and belief.</p> <p><i>Pat Perez</i> Signature</p> <p>Pat Perez Printed Name</p> <p>Regulatory Agent Title</p> <p>10-30-01 Date</p>	
	<p><b>SURVEYOR CERTIFICATION</b></p> <p>I hereby certify that the well location shown on this plat was plotted from field notes of actual surveys made by me or under my supervision, and that the same is true and correct to the best of my belief.</p> <p>10/25/2001 Date Surveyed</p> <p><i>[Signature]</i> Signature and Seal of Professional Surveyor</p> <p>HERSCHEL L. JONES NEW MEXICO 3840 SURVEYOR</p> <p>Certificate No. Herschel L. Jones RLS 3640 GEORGE 11 GENERAL SURVEYING COMPANY</p>	
	<p>George QJ Federal #10</p>	
	<p>6605/1500 W</p>	

**YATES PETROLEUM CORPORATION**  
**George "QJ" Federal Com. #11**  
 1980' FNL and 1650' FWL  
 Section 26,-T6S-R25E  
 Chaves County, New Mexico

1. The estimated tops of geologic markers are as follows:

San Andres	500'
Glorieta	1465'
Yeso	1545'
Tubb	2980'
Abo	3615'
Wolfcamp	4385'
Cisco	4880'
Strawn	5030'
Basement	5135'
TD	5285'

2. The estimated depths at which anticipated water, oil or gas formations are expected to be encountered:

Water: 150'-200'  
 Oil or Gas: All potential zones.

3. Pressure Control Equipment: BOPE will be installed on the 11 3/4" casing and rated for 2000 BOP systems will be consistent with API RP 53. Pressure tests will be conducted before drilling out from under all casing strings which are set and cemented in place. Blowout Preventor controls will be installed prior to drilling the surface plug and will remain in use until the well is completed or abandoned. Preventors will be inspected and operated at least daily to ensure good mechanical working order, and this inspection recorded on the daily drilling report. See Exhibit B.

Auxiliary Equipment:

A. Auxiliary Equipment: Kelly cock, pit level indicators, flow sensor equipment and a sub with full opening valve to fit the drill pipe and collars will be available on the rig floor in the open position at all times for use when kelly is not in use.

4. THE PROPOSED CASING AND CEMENTING PROGRAM:

A. Casing Program: (All New)

	<u>Hole Size</u>	<u>Casing Size</u>	<u>Wt./Ft</u>	<u>Grade</u>	<u>Coupling</u>	<u>Interval</u>
<b>WITNESS</b>	3/4"	11 3/4"	42#	H-40	ST&C	0-900'
	11"	8 5/8"*	24#	J-55	ST&C	0-1500'
	7 7/8"	5 1/2"	15.5#	J-55	ST&C	0-5285'

\*8 5/8" will only be set if lost circulation is encountered

1. Minimum Casing Design Factors: Collapse 1.125, Burst 1.0, Tensile Strength 1.8
2. Yates Petroleum Corporation requests that a variance be granted in requiring the casing and BOPE to be tested to 2000 PSI to testing the casing and BOPE to 1000 PSI. The rig pumps will be used to test the casing and BOPE. Rig pumps used in this area cannot safely test above 1000 PSI. We would have to go to the greater expense of hiring an independent service to do the testing. Also, the maximum shut-in bottom hole pressure is 1100 PSI. Pressure at the surface is much less. Most of the time the Abo formation requires treatment before it flows.

A. CEMENTING PROGRAM:

Surface Casing: 350 sx Lite "C" (YLD 2.0 WT 12.5). Tail in with 200 sx "C" + 2% CaCL2 (YLD 1.33 WT 15.6).

Intermediate Casing: 250 sx class C +2% CACLW (YLD 1.32 WT 14.8)

Production Casing: 500 sx Pecos Valley Lite (YLD 1.34 WT 13.0). TOC 3100'.

5. MUD PROGRAM AND AUXILIARY EQUIPMENT:

<u>Interval</u>	<u>Type</u>	<u>Weight</u>	<u>Viscosity</u>	<u>Fluid Loss</u>
0-900'	FW GEL, Paper, LCM	8.6 - 9.6	32-36	N/C
900'-3580'	Cut Brine/Brine	9.0 - 10.2	28	N/C
3580'-5285'	Starch/Salt Gel	9.3 -10.2	32-40	<6/cc

Sufficient mud material(s) to maintain mud properties, control lost circulation and contain a blow out will be available at the well site during drilling operations. Mud will be checked hourly by rig personnel.

6. EVALUATION PROGRAM:

Samples: 10' samples out from under surface casing.

Logging: Sch: Plat form Express; CNL/LDT, W/NGT TD-Surf csg; with CNL/GR up to Surf; DLL/MSFL TD-Surf csg

Coring: Possible

DST's: As warranted.

7. ABNORMAL CONDITIONS, BOTTOM HOLE PRESSURE, AND POTENTIAL HAZARDS:

Anticipated BHP:

From: 0 TO: 900' Anticipated Max. BHP: 375 PSI

From: 900' TO: 5285' Anticipated Max. BHP: 2700 PSI

Abnormal Pressures Anticipated: None

Lost Circulation Zones Anticipated: None.

H2S Zones Anticipated: None Anticipated

Maximum Bottom Hole Temperature: 110 F

8. ANTICIPATED STARTING DATE:

Plans are to drill this well as soon as possible after receiving approval. It should take approximately 25 days to drill the well with completion taking another 20 days.

**MULTI-POINT SURFACE USE AND OPERATIONS PLAN**  
**George "QJ" Federal Com. #11**  
1980' FNL and 1650' FWL  
Section 26,-T6S-R25E  
Chaves County, New Mexico

This plan is submitted with Form 3160-3, Application for Permit to Drill, covering the above described well. The purpose of this plan is to describe the location of the proposed well, the proposed construction activities and operations plan, the magnitude of the surface disturbance involved and the procedures to be followed in rehabilitating the surface after completion of the operations, so that a complete appraisal can be made of the environmental effect associated with the operations.

1. EXISTING ROADS:

Exhibit A is a portion of the BLM map showing the well and roads in the vicinity of the proposed location. The proposed wellsite is located approximately 34 miles northeast of Roswell, New Mexico and the access route to the location is indicated in red and green on Exhibit A.

DIRECTIONS:

Go north of Roswell on Highway 285 for approx. 26.5 miles to Cottonwood Road. Turn east and follow road approx. 12.8 miles (just before ranch house) turn left and follow road left (NW) at fork. Continue on road approx.  $\frac{3}{4}$  of a mile. The access road is staked on the right (N) side of the road going north approx. 150' to the southwest corner of the location.

2. PLANNED ACCESS ROAD:

- A. The proposed new access will be approximately 150' in length from the point of origin to the southwest corner of the drilling pad. The road will lie in a north to south direction.
- B. The new road will be 14 feet in width (driving surface) and will be adequately drained to control runoff and soil erosion.
- C. Existing roads will be maintained in the same or better condition.

3. LOCATION OF EXISTING WELL:

- A. There is drilling activity within a one-mile radius of the wellsite.
- B. Exhibit D shows existing wells within a one-mile radius of the proposed wellsite.

4. LOCATION OF EXISTING AND/OR PROPOSED FACILITIES:

- A. There are production facilities on this lease at the present time.
- B. In the event that the well is productive, the necessary production facilities will be installed on the drilling pad. If the well is productive oil, a gas or diesel self-contained unit will be used to provide the necessary power. No power will be required if the well is productive of gas.

5. LOCATION AND TYPE OF WATER SUPPLY:

- A. It is planned to drill the proposed well with a fresh water system. The water will be obtained from commercial sources and will be hauled to the location by truck over the existing and proposed roads shown in Exhibit A.

6. SOURCE OF CONSTRUCTION MATERIALS:

Dirt contractor will locate nearest pit and obtain any permits and materials needed for construction.

7. METHODS OF HANDLING WASTE DISPOSAL:

- A. Drill cuttings will be disposed of in the reserve pits.
- B. Drilling fluids will be allowed to evaporate in the reserve pits until the pits are dry.
- C. Water produced during operations will be collected in tanks until hauled to an approved disposal system, or separate disposal application will be submitted.
- D. Oil produced during operations will be stored in tanks until sold.
- E. Current laws and regulations pertaining to the disposal of human waste will be complied with.
- F. All trash, junk, and other waste materials will be contained in trash cages or bins to prevent scattering and will be removed and deposited in an approved sanitary land fill. Burial on site is not approved.

8. ANCILLARY FACILITIES: NONE

9. WELLSITE LAYOUT:

- A. Exhibit C shows the relative location and dimensions of the well pad, the reserve pits, the location of the drilling equipment, rig orientation and access road approach.
- B. The reserve pits will be plastic lined.
- C. A 400' x 400' area has been staked and flagged.

10. PLANS FOR RESTORATION:

- A. After finishing drilling and/or completion operations, all equipment and other material not needed for further operations will be removed. The location will be cleaned of all trash and junk to leave the wellsite in as aesthetically pleasing a condition as possible.
- B. Unguarded pits, if any, containing fluids will be fenced until they have dried and been leveled.
- C. If the proposed well is non-productive, all rehabilitation and/or vegetation requirements of the Bureau of Land Management will be complied with and will be accomplished as expeditiously as possible. All pits will be filled level after they have evaporated and dried.

11. SURFACE OWNERSHIP: Bureau of Land Management  
Roswell, New Mexico.

12. OTHER INFORMATION:

- A. Topography: Refer to the existing archaeological report for a description of the topography, flora, fauna, soil characteristics, dwellings, historical and cultural sites.
- B. The primary surface use is for grazing.

13. OPERATOR'S REPRESENTATIVE:

- |   |   |
|---|---|
| A. Through A.P.D. Approval:<br>Pat Perez, Permit Agent<br>Yates Petroleum Corporation<br>105 South Fourth Street<br>Artesia, New Mexico 88210<br>Phone (505) 748-1471 | B. Through Drilling, Completions & Prod.<br>Pinson McWhorter, Operations Manager<br>Yates Petroleum Corporation<br>105 South Fourth Street<br>Artesia, New Mexico 88210<br>Phone (505) 748-1471 |
|---|---|

14. CERTIFICATION:

I hereby certify that I, or persons under my direct supervision, have inspected the proposed drill site and access route, that I am familiar with the conditions which presently exist; that the statements made in this plan are to the best of my knowledge, true and correct; and , that the work associated with the operations proposed herein will be performed by Yates Petroleum Corporation and its contractors and subcontractors in conformity with this plan and the terms and conditions under which it is approved. This statement is subject to the provisions of 18 U.S.C. 1001 for the filing of a false statement.

10/05/2001

  
\_\_\_\_\_  
Regulatory Agent



Yates Petroleum Corporation  
George "QJ" Federal #11  
1980' FNL and 1650' FWL  
Section 26-T6S-R25E  
Chaves County, New Mexico  
Exhibit "A"

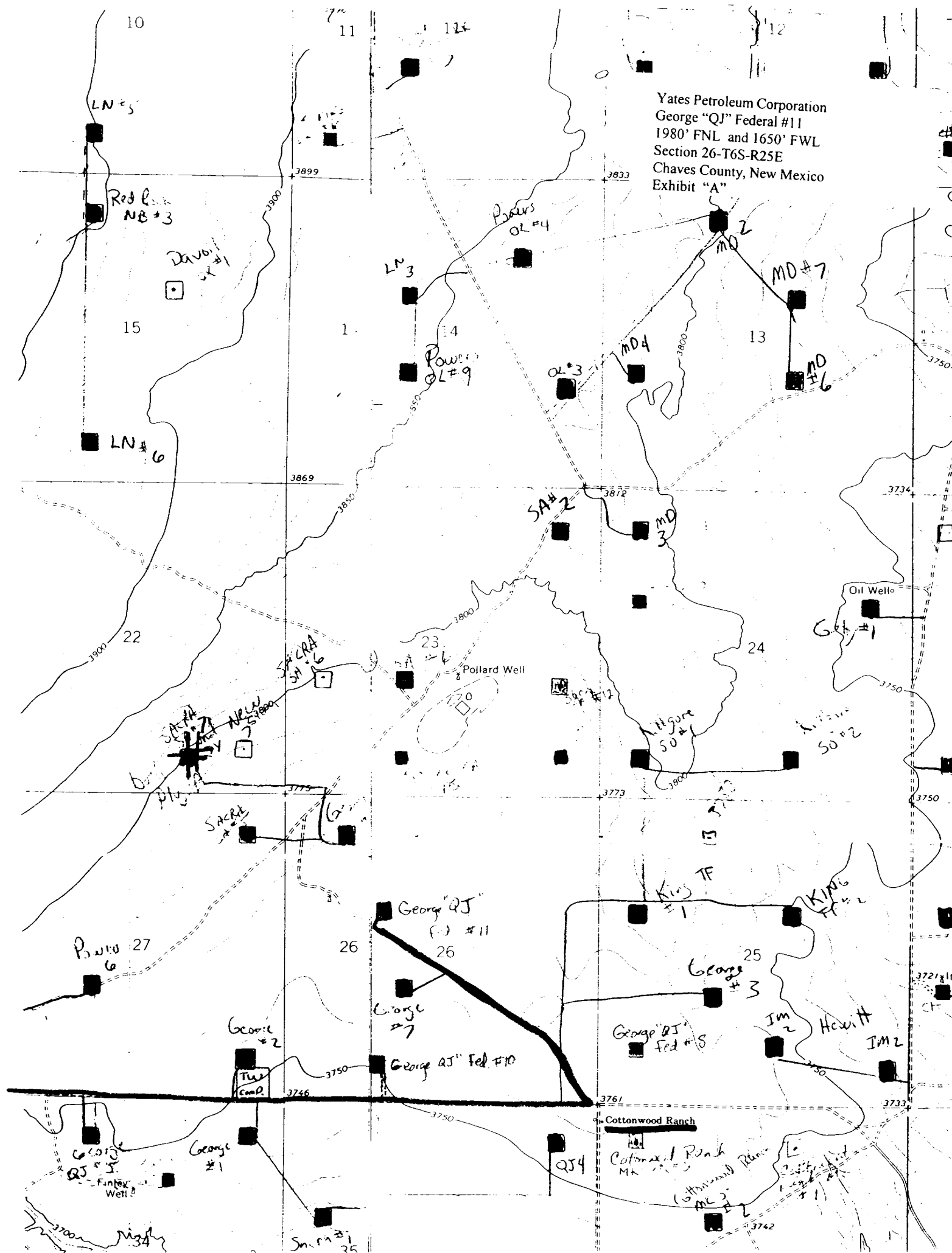

SECTION 26, TOWNSHIP 6 SOUTH, RANGE 25 EAST, NMPM, CHAVES COUNTY, NEW MEXICO.

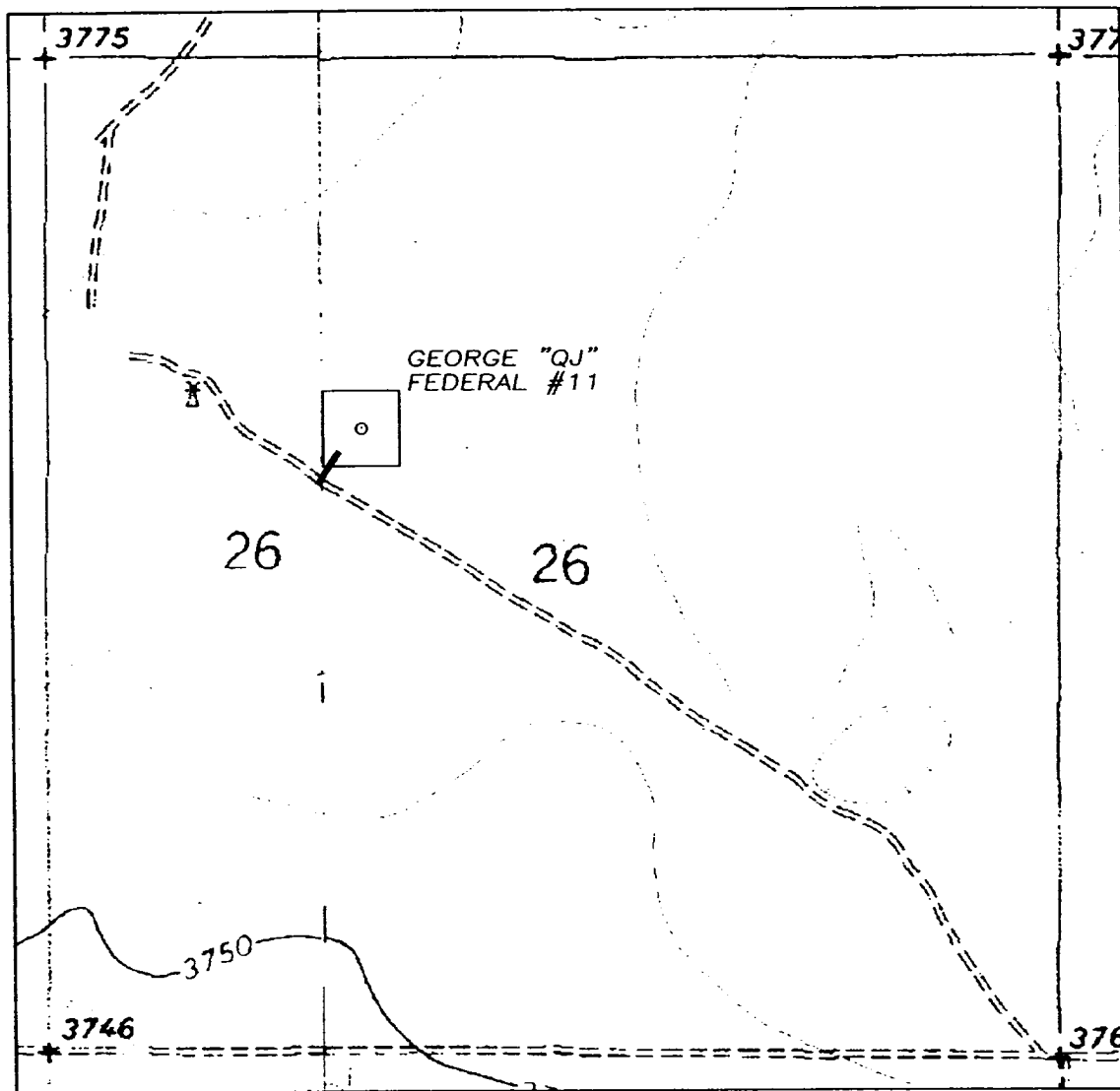

Yates Petroleum Corporation  
 George "QJ" Federal #11  
 1980' FNL and 1650' FWL  
 Section 26-T6S-R25E  
 Chaves County, New Mexico  
 Exhibit "A-1"

1000' 0 1000' 2000'  
 Scale 1" = 1000'

THE PREPARATION OF THIS MAP AND THE PERFORMANCE OF THE SURVEY UPON WHICH IT IS BASED WERE DONE UNDER MY DIRECTION AND THE PLAT ACCURATELY DEPICTS THE RESULTS OF SAID SURVEY AND MEET THE REQUIREMENTS OF THE STANDARDS FOR LAND SURVEYS IN NEW MEXICO AS ADOPTED BY THE NEW MEXICO STATE BOARD OF REGISTRATION FOR PROFESSIONAL ENGINEERS AND LAND SURVEYORS.

*Herschel Jones*  
 HERSCHEL JONES, P.L.S. No. 3640  
 PROFESSIONAL LAND SURVEYOR

GENERAL SURVEYING COMPANY P.O. BOX 1928  
 LOVINGTON, NEW MEXICO 88260

**YATES PETROLEUM CORP.**

LEASE ROAD TO ACCESS THE YATES GEORGE "QJ" FEDERAL #11, LOCATED IN SECTION 26, TOWNSHIP 6 SOUTH, RANGE 25 EAST, NMPM, CHAVES COUNTY, NEW MEXICO.

Survey Date: 9/26/2001	Sheet 1 of 1 Sheets
Drawn By: Ed Blevins	W.O. Number
Date: 9/26/01	Scale 1" = 1000' GEORGE 1

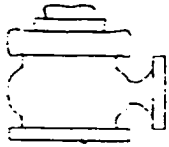

# Yates Petroleum Corporation

BOP-2

## Typical 2,000 psi Pressure System Schematic Double Ram Preventer Stack

Yates Petroleum Corporation  
George "QJ" Federal #11  
1980' FNL and 1650' FWL  
Section 26-T6S-R25E  
Chaves County, New Mexico  
Exhibit "B"

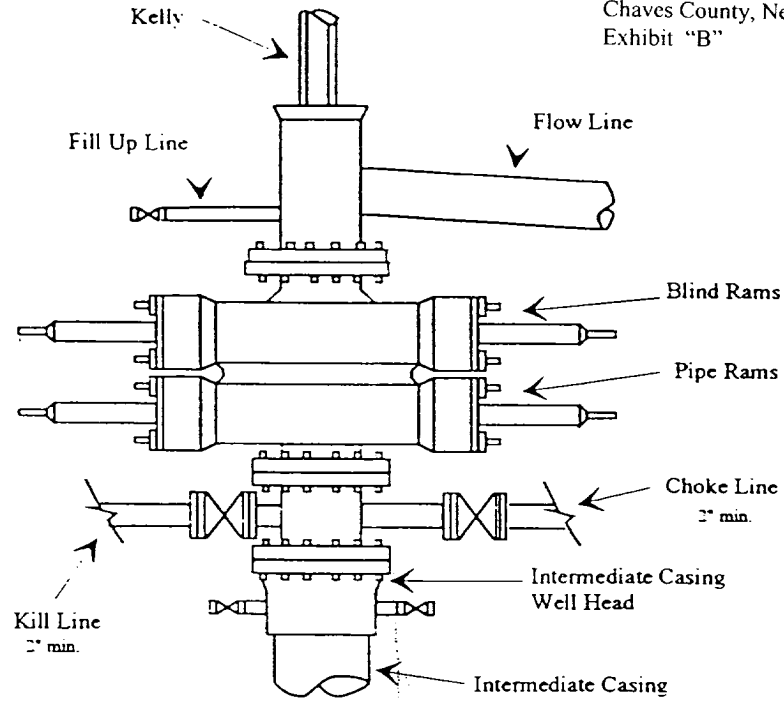

Typical 2,000 psi choke manifold assembly with at least these minimum features

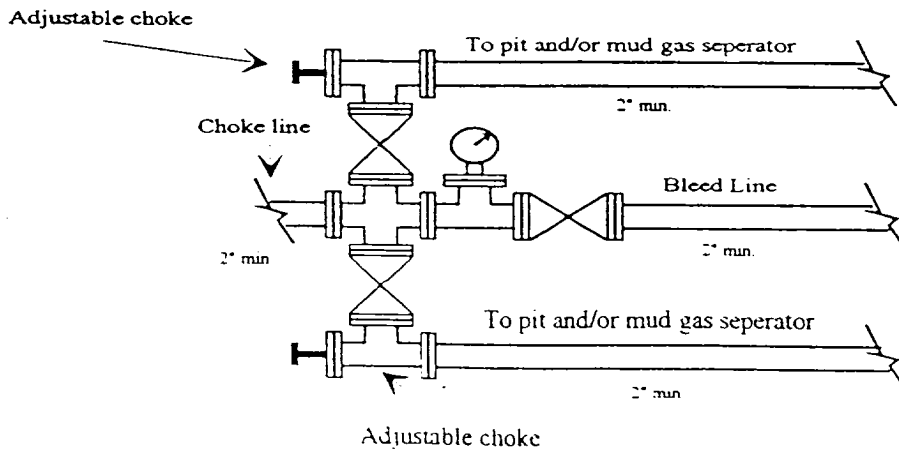

# Yates Petroleum Corporation

## Location Layout for Permian Basin

### Up to 12,000'

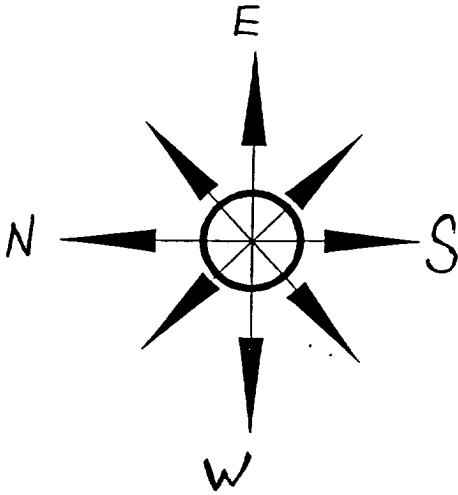

Yates Petroleum Corporation  
 George "QJ" Federal #11  
 1980' FNL and 1650' FWL  
 Section 26-T6S-R25E  
 Chaves County, New Mexico  
 Exhibit "C"

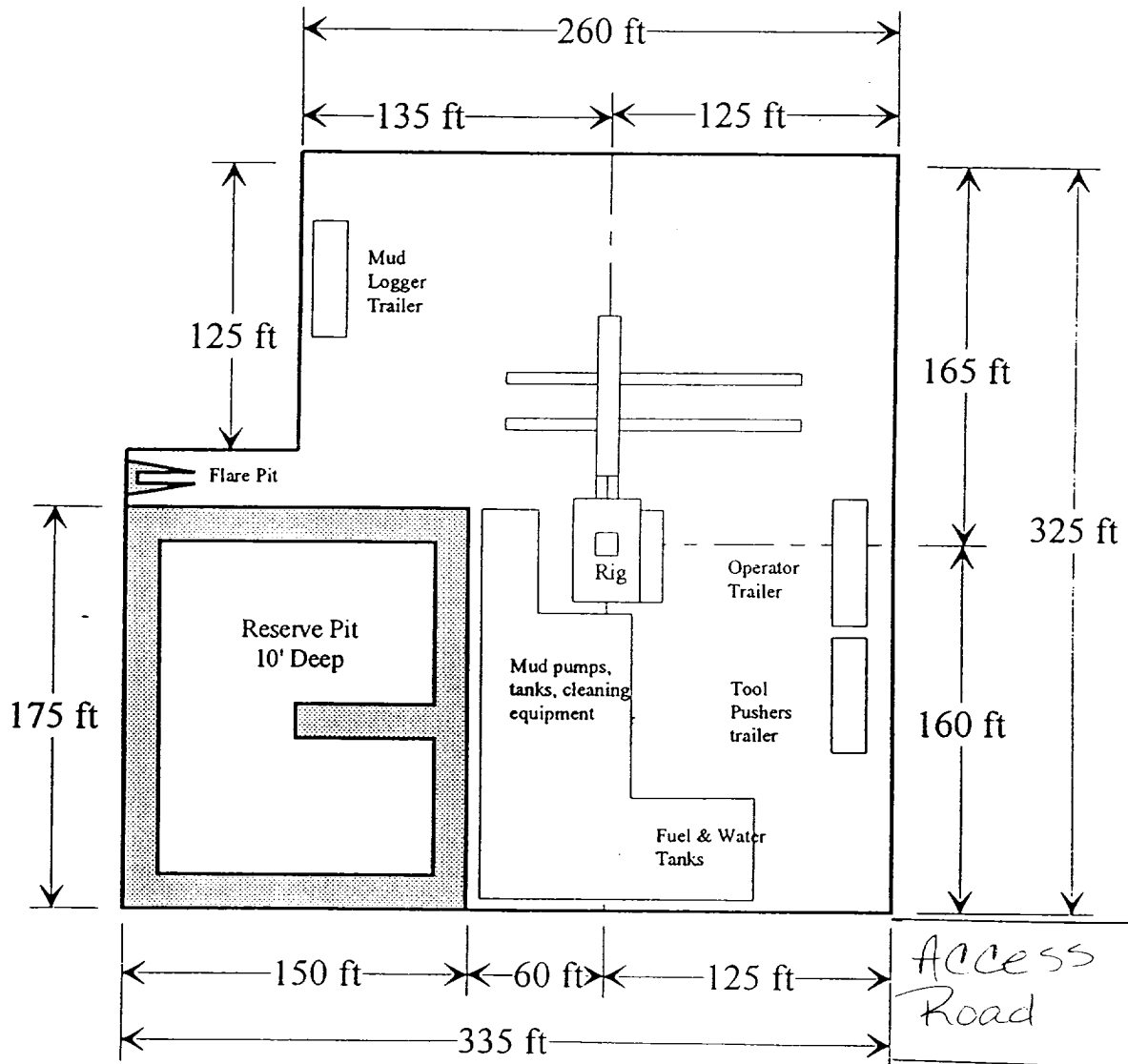

Distance from Well Head to Reserve Pit will vary between rigs

The above dimension should be a maximum

Yates Petroleum Corporation  
 George "QJ" Federal #11  
 1980' FNL and 1650' FWL  
 Section 26-T6S-R25E  
 Chaves County, New Mexico  
 Exhibit "D"

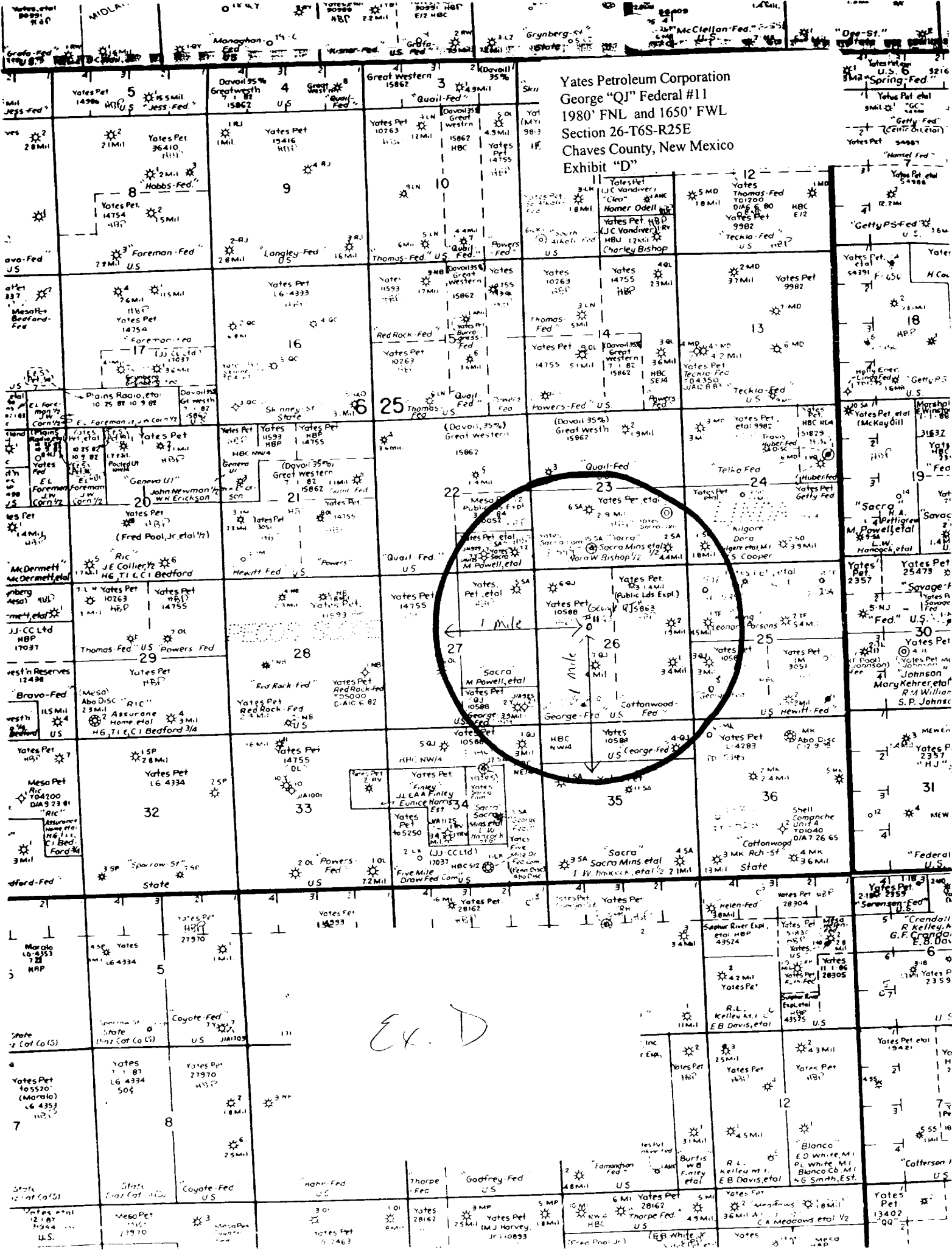

EX. D