

ates Petroleum Corporation

BOP-3

Typical 3,000 psi Pressure System Schematic Annular with Double Ram Preventer Stack

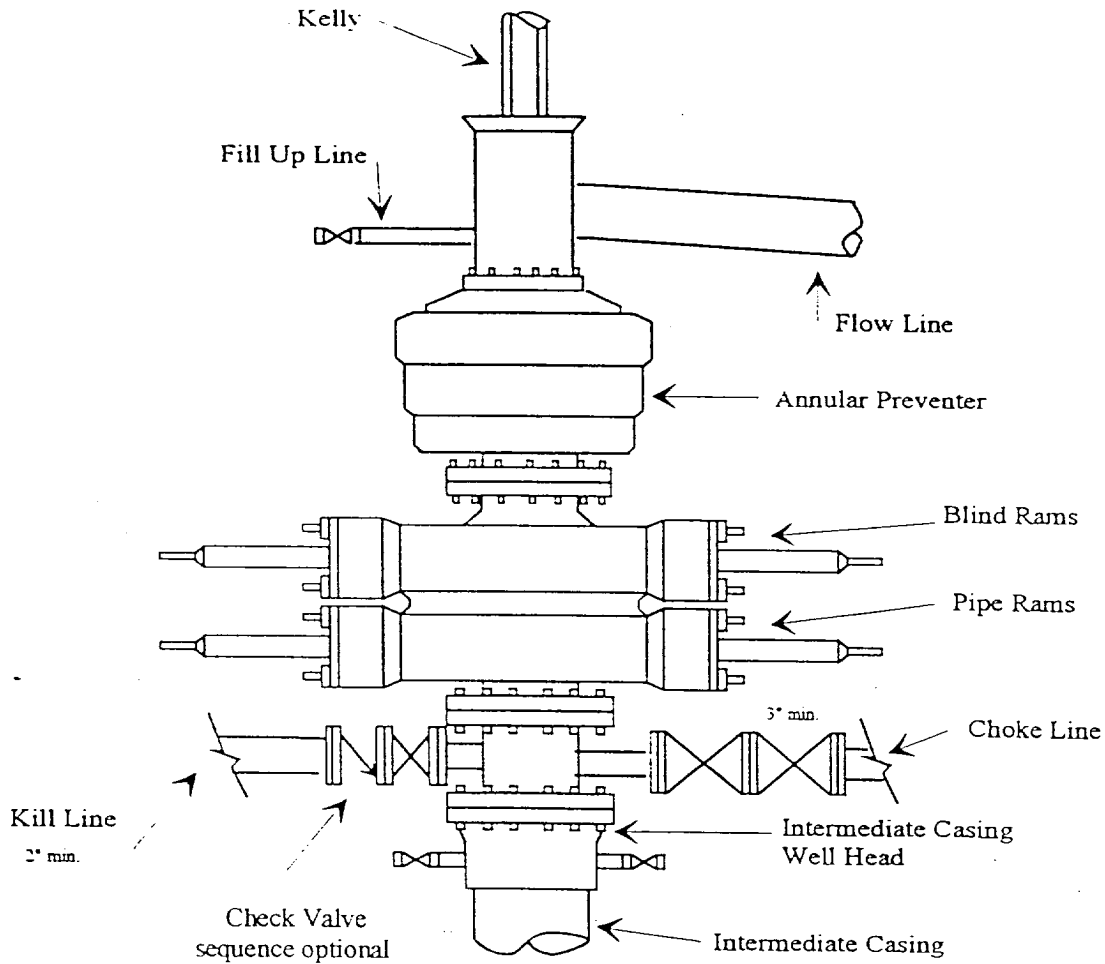

Typical 3,000 psi choke manifold assembly with at least these minimum features

