

UNITED STATES  
DEPARTMENT OF THE INTERIOR  
BUREAU OF LAND MANAGEMENT

FORM APPROVED  
OMB NO. 1004-0135  
Expires: November 30, 2000

**SUNDRY NOTICES AND REPORTS ON WELLS**  
*Do not use this form for proposals to drill or to re-enter an abandoned well. Use form 3160-3 (APD) for such proposals.*

**SUBMIT IN TRIPLICATE - Other instructions on reverse side.**

1. Type of Well <input type="checkbox"/> Oil Well <input checked="" type="checkbox"/> Gas Well <input type="checkbox"/> Other		5. Lease Serial No. NMNM - 077111
2. Name of Operator BP AMERICA PRODUCTION COMPANY		6. If Indian, Allottee or Tribe Name
3a. Address P.O. BOX 3092 HOUSTON, TX 77253		7. If Unit or CA/Agreement, Name and/or No.
3b. Phone No. (include area code) Ph: 281.366.4491 Fx: 281.366.0700		8. Well Name and No. STOREY C LS 5
4. Location of Well (Footage, Sec., T., R., M., or Survey Description) Sec 35 T28N R9W SWNW 1973FNL 402FWL		9. API Well No. 30-045-07018
		10. Field and Pool, or Exploratory BLANCO PICTURED CLIFFS SOUTH
		11. County or Parish, and State SAN JUAN COUNTY, NM

12. CHECK APPROPRIATE BOX(ES) TO INDICATE NATURE OF NOTICE, REPORT, OR OTHER DATA

TYPE OF SUBMISSION	TYPE OF ACTION			
<input checked="" type="checkbox"/> Notice of Intent	<input type="checkbox"/> Acidize	<input type="checkbox"/> Deepen	<input type="checkbox"/> Production (Start/Resume)	<input type="checkbox"/> Water Shut-Off
<input type="checkbox"/> Subsequent Report	<input type="checkbox"/> Alter Casing	<input type="checkbox"/> Fracture Treat	<input type="checkbox"/> Reclamation	<input type="checkbox"/> Well Integrity
<input type="checkbox"/> Final Abandonment Notice	<input type="checkbox"/> Casing Repair	<input type="checkbox"/> New Construction	<input type="checkbox"/> Recomplete	<input type="checkbox"/> Other
	<input type="checkbox"/> Change Plans	<input checked="" type="checkbox"/> Plug and Abandon	<input type="checkbox"/> Temporarily Abandon	
	<input type="checkbox"/> Convert to Injection	<input type="checkbox"/> Plug Back	<input type="checkbox"/> Water Disposal	

13. Describe Proposed or Completed Operation (clearly state all pertinent details, including estimated starting date of any proposed work and approximate duration thereof. If the proposal is to deepen directionally or recomplate horizontally, give subsurface locations and measured and true vertical depths of all pertinent markers and zones. Attach the Bond under which the work will be performed or provide the Bond No. on file with BLM/BIA. Required subsequent reports shall be filed within 30 days following completion of the involved operations. If the operation results in a multiple completion or recomplate in a new interval, a Form 3160-4 shall be filed once testing has been completed. Final Abandonment Notices shall be filed only after all requirements, including reclamation, have been completed, and the operator has determined that the site is ready for final inspection.)

BP America request permission to plug and abandon the subject well as per the attached procedure.



14. I hereby certify that the foregoing is true and correct.

**Electronic Submission #31888 verified by the BLM Well Information System  
For BP AMERICA PRODUCTION COMPANY, sent to the Farmington**

Name (Printed/Typed) MARY CORLEY	Title AUTHORIZED REPRESENTATIVE
Signature (Electronic Submission)	Date 06/14/2004

**THIS SPACE FOR FEDERAL OR STATE OFFICE USE**

Approved By <i>[Signature]</i>	Title <i>PE</i>	Date JUN 29 2004
Conditions of approval, if any, are attached. Approval of this notice does not warrant or certify that the applicant holds legal or equitable title to those rights in the subject lease which would entitle the applicant to conduct operations thereon.		Office <i>FFO</i>

Title 18 U.S.C. Section 1001 and Title 43 U.S.C. Section 1212, make it a crime for any person knowingly and willfully to make to any department or agency of the United States any false, fictitious or fraudulent statements or representations as to any matter within its jurisdiction.

**\*\* OPERATOR-SUBMITTED \*\* OPERATOR-SUBMITTED \*\* OPERATOR-SUBMITTED \*\***

**NMOC**

**Storey C LS 5  
Plug and Abandonment Procedure**

---

**Procedure:**

1. Hold safety meeting and perform JSA.
2. Contact BLM and NMOCD 24 hrs prior to beginning operations.
3. Check and record tubing, casing, and bradenhead pressures.
4. Nipple down WH. NU BOPs and diversion spool with 3" outlets and 3" pipe to the blow tank. Pressure test BOPs to 500 psi. Monitor flowing casing pressure with gauge (with casing flowing to blow tank) throughout workover.
5. TOH with 1-1/4" production tubing currently set at 2975'.
6. PU 2-3/8 workstring and strip cement plug from PBTD to 2,020'.
7. RU wireline unit. Perforate squeeze holes at +/-2000
8. Set cement retainer at 1,500'. Sting into retainer and establish circulation up annulus. Pump cement to fill from retainer to 1500' on annulus.
9. Perforate squeeze holes at ~~800~~<sup>878</sup>'. Establish circulation down casing and up annulus. Spot balance plug from ~~800~~<sup>878</sup> to surface on inside and outside of casing.
10. Install 4' cement well marker and identification plate per NMOCD requirements.
11. Restore location.

# Storey C LS 5

Sec 35, T28N, R9W

API: 30-045-07018

6798' GL

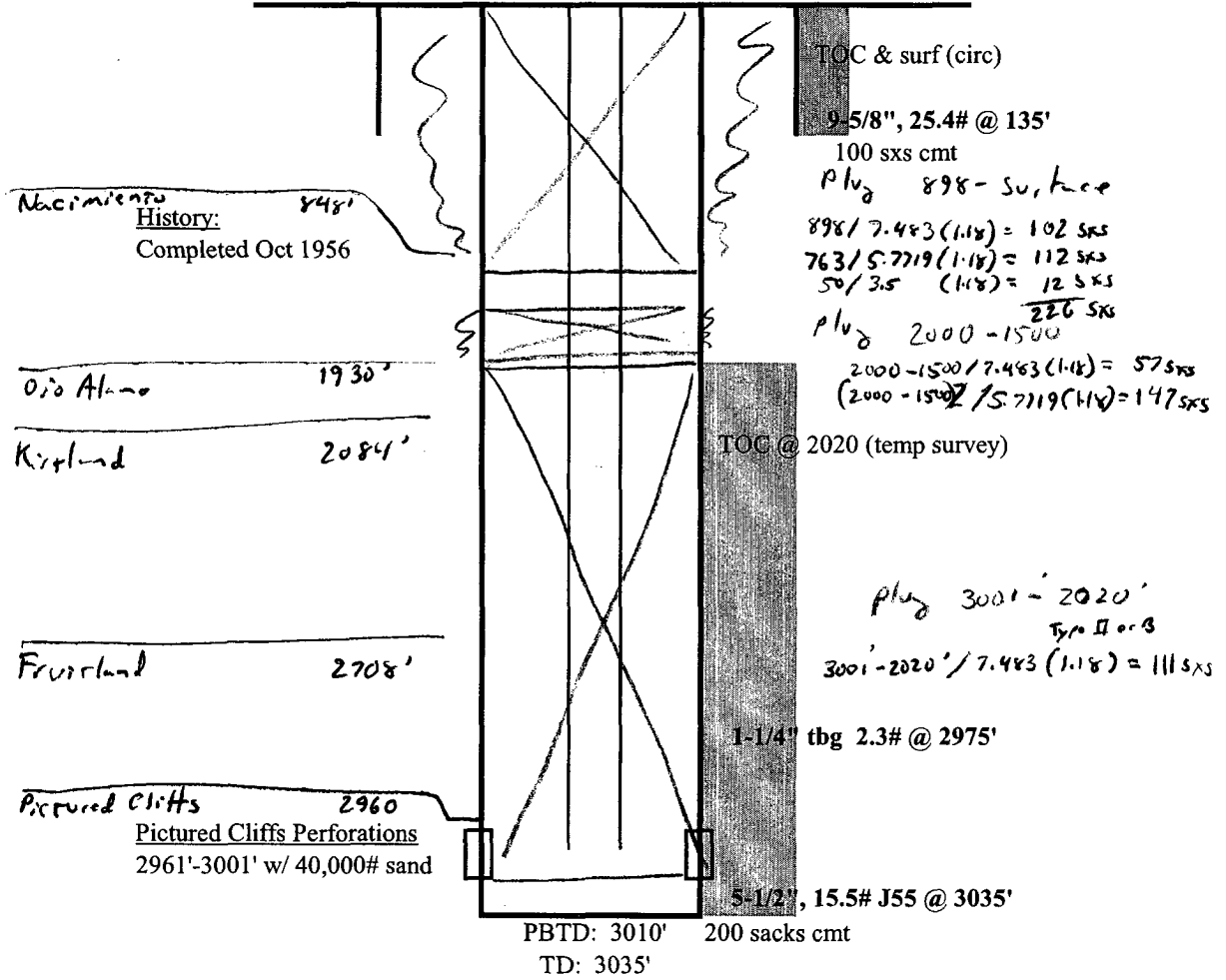

updated: 6/11/04 CFR