

NEW MEXICO OIL CONSERVATION COMMISSION

SANTA FE, NEW MEXICO

OK 94 file

7-3-58

APPLICATION FOR DUAL COMPLETION

Field Name Blanco		County Rio Arriba		Date October 14, 1958
Operator Magnolia Petroleum Company		Lease Cheney Federal		Well No. #2
Location of Well	Unit N	Section 17	Township 26N	Range 2W

1. Has the New Mexico Oil Conservation Commission heretofore authorized the dual completion of a well in these same pools or in the same zones within one mile of the subject well? YES NO
2. If answer is yes, identify one such instance: Order No. **DC 672**; Operator, Lease, and Well No.: **Magnolia Petroleum Company's Jicarilla "G" Well #7**

3. The following facts are submitted:

	Upper Zone	Lower Zone
a. Name of reservoir	Pictured Cliffs	Mesaverde
b. Top and Bottom of Pay Section (Perforations)	3778' 3805'	5548' 6026'
c. Type of production (Oil or Gas)	Gas	Gas
d. Method of Production (Flowing or Artificial Lift)	Temporary Abandon	Flowing

4. The following are attached. (Please mark YES or NO)
- Yes** a. Diagrammatic Sketch of the Dual Completion, showing all casing strings, including size and setting, top of cement, perforated intervals, tubing strings, including diameters and setting depth, location and type of packers and side door chokes, and such other information as may be pertinent.
- Yes** b. Plat showing the location of all wells on applicant's lease, all offset wells on offset leases, and the names and addresses of operators of all leases offsetting applicant's lease.
- Yes** c. Waivers consenting to such dual completion from each offset operator, or in lieu thereof, evidence that said offset operators have been furnished copies of the application.*
- Yes** d. Electrical log of the well or other acceptable log with tops and bottoms of producing zones and intervals of perforation indicated thereon. (If such log is not available at the time application is filed, it shall be submitted as provided by Rule 112-A.)

5. List all offset operators to the lease on which this well is located together with their correct mailing address.
- San Juan Oil Company, Box 548, Andrews, Texas**
- Humble Oil & Refining Company, Box 2347, Hobbs, New Mexico**

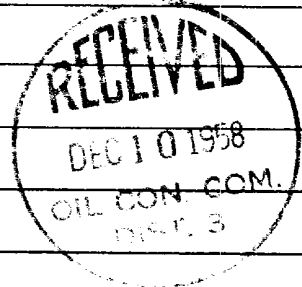

6. Were all operators listed in Item 5 above notified and furnished a copy of this application? YES NO . If answer is yes, give date of such notification **October 2, 1958**

CERTIFICATE: I, the undersigned, state that I am the **District Superintendent** of the **Magnolia Petroleum Company** (company), and that I am authorized by said company to make this report; and that this report was prepared under my supervision and direction and that the facts stated therein are true, correct and complete to the best of my knowledge.

M. Young, Jr.
Signature

* Should waivers from all offset operators not accompany an application for administrative approval, the New Mexico Oil Conservation Commission will hold the application for a period of twenty (20) days from date of receipt by the Commission's Santa Fe office. If, after said twenty-day period, no protest nor request for hearing is received by the Santa Fe office, the application will then be processed.

NOTE: If the proposed dual completion will result in an unorthodox well location and/or a non-standard proration unit in either or both of the producing zones, then separate application for approval of the same should be filed simultaneously with this application.

NEW MEXICO OIL CONSERVATION COMMISSION
SANTA FE, NEW MEXICO

6-1-56

PACKER-SETTING AFFIDAVIT
(Dual Completions)

STATE OF NEW MEXICO)
County of SAN JUAN) ss

G. W. Walker, being first duly sworn according to law, upon his oath deposes and says:

That he is of lawful age and has full knowledge of the facts herein below set out.

That he is employed by Magnolia Petroleum Company in the capacity of Production Foreman and as such is its authorized agent.

That on July 30, 1958, he personally supervised the setting of a Baker Model "D" in Magnolia Petroleum Company's
(Make and Type of Packer) (Operator)

Cheney Federal Well No. 2, located in Unit
(lease)
Letter M, Section 17, Township 26N, Range 2W, NMPM,
Rio Arriba County, New Mexico.

That said packer was set at a subsurface depth of 5512 feet, said depth measurement having been furnished by Perforating Guns Atlas Corporation

That the purpose of setting this packer was to effect a seal in the annular space between the two strings of pipe where the packer was set so as to prevent the comingling, within the well-bore, of fluids produced from a stratum below the packer with fluids produced from a stratum above the packer. That this packer was properly set and that it did, when set, effectively and absolutely seal off the annular space between the two strings of pipe where it was set in such manner as that it prevented any movement of fluids across the packer.

Magnolia Petroleum Company
(Company)

G. W. Walker
(its Agent) G. W. Walker

Subscribed and sworn to before me this the 4th day of Aug, AD, 1958.

Lacey D. Bryant
Notary Public in and for the County of San Juan.

My Commission Expires 3-7-62.

MAGNOLIA PETROLEUM COMPANY

CHERRY FEDERAL WELL NO. 2
BLANCO MEADOWS & UND. PICTURED CLIFFS
RIO ARriba COUNTY, NEW MEXICO

ELEVATION - 7304 Ground Level

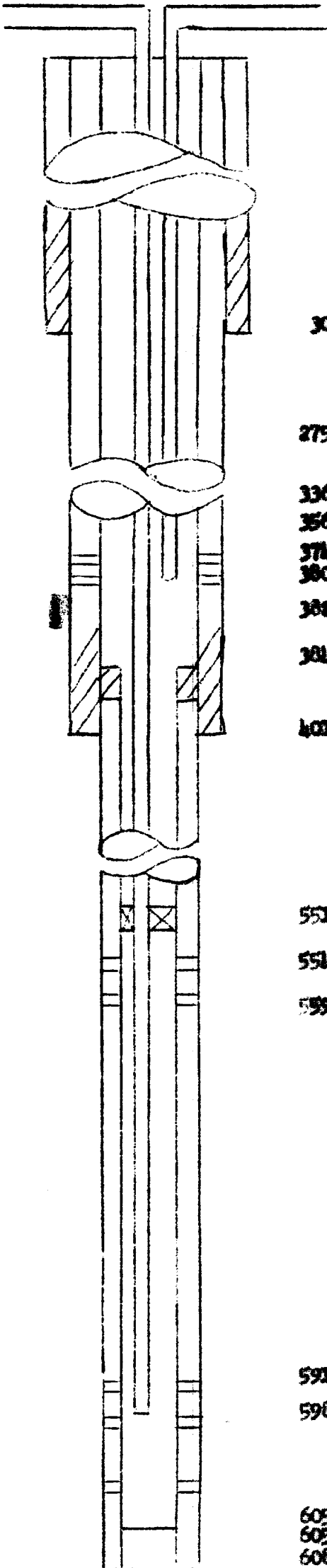

304' - Bottom 10-3/4" Cas. Set w/225 Sacks Cement

2750' - Top of Cement

3366' - Top of Ojo Alamo

3560' - Top of Kirtland Fruitland

3744' - Top of Pictured Cliffs

3804' - Bottom 2" Tubing

3826' - Top of Leads

4043' - Top of 5" Liner & Top of Cement

4044' - Bottom 7-5/8" Cas. Set w/130 Sacks Cement

5512' - Baker Medal "B" Production Packer

5548' - Top of Cliffhouse

5999' - Top of Manatee

5919' - Top of Point Lookout

5988' - Bottom of 2" Tubing

6052' - Plugged Back Total Depth

6059' - Top of Manatee

6085' - Total Depth - Bottom 5" Liner Set w/225 Sacks Cement

Perforated 7-5/8" Cas.
 w/2 Shots Per Foot
 3778 - 84
 3788 - 3805

Perforated 5" Liner
 w/2 Shots Per Foot
 5548 - 64
 5572 - 83
 5919 - 37
 5988 - 99
 6018 - 26



1. Introduction

2. Methodology

3. Results

4. Discussion

5. Conclusion

6. References

7. Appendix

8. Acknowledgements

9. Contact Information

10. Disclaimer

11. Copyright

12. Privacy Policy

13. Terms of Service

14. About Us

15. FAQ

16. Sitemap

17. Glossary

18. Index

19. Search

20. Feedback

21. Help

22. Support

23. Contact

24. Privacy

25. Terms

26. About

27. FAQ

28. Sitemap

29. Glossary

30. Index

31. Search

32. Feedback

33. Help

34. Support

35. Contact

36. Privacy