

EPWG

Location Pit Closure

Record

1641

Well Name: King 1-PC

MTR#: 72-674

Oper #: 2999 Oper: Meridian oil Inc.

District: aztec

Co-ordinate Information:

Unit: A

Section: 22

Township: 30

Range: 10

* Pit Type (circle one): DEH LID LOD SEP

Length: 24

Width: 24 SQFT 576

Duck Netting: Yes No

Fill Dirt: Yes No

Approx. cu.yds.:

Vacuum Truck: Yes No

Approx. Bbls:

Date Started: 6-23-92

Date Completed: 6-23-92

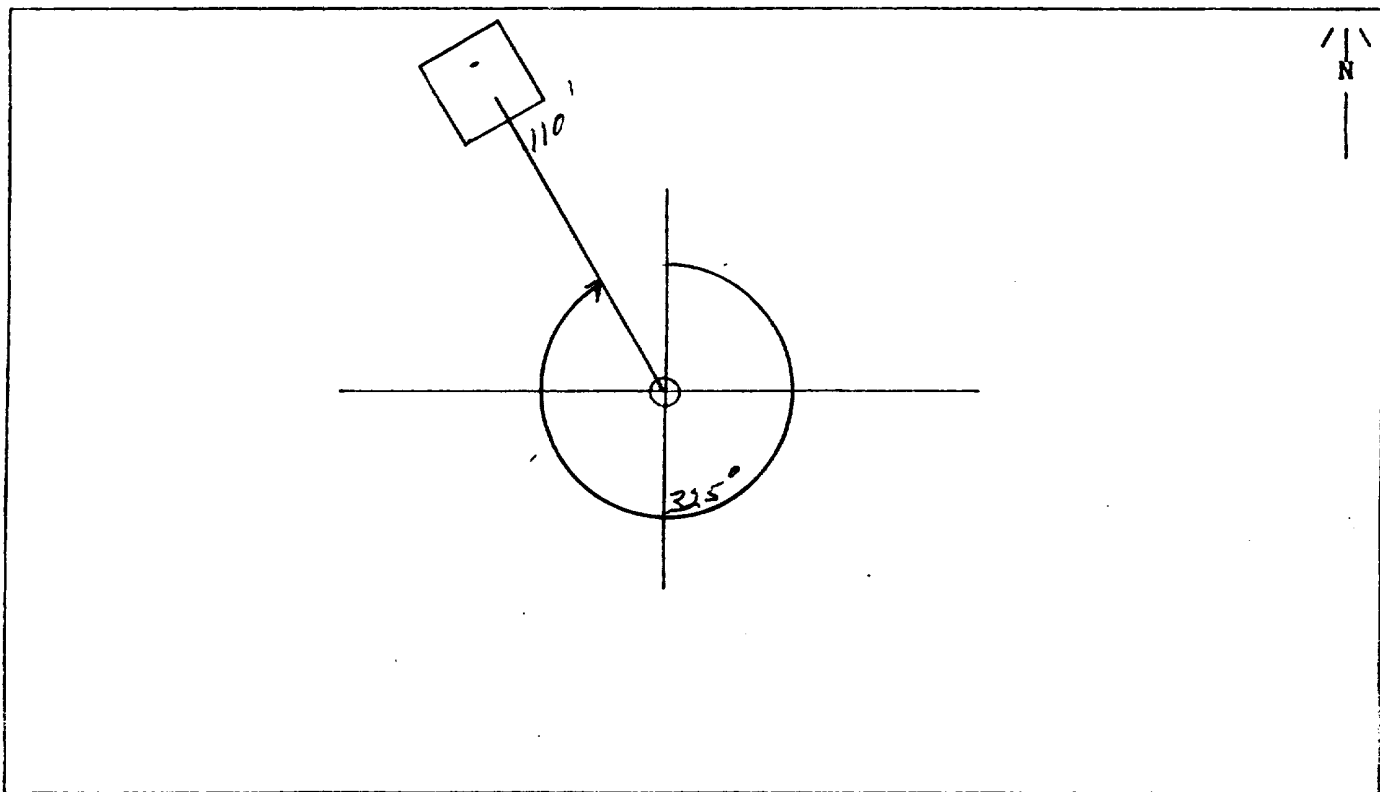

Jerry A. Locates
Signature of Inspector

Remarks: _____

• DEH=Dehydrator Pit LID=Line Drip(Syphon)
 LOD=Location Drip SEP=Sperator



LTR



Job separation sheet

District I
PO Box 1980, Hobbs, NM 88241-1980

District II
P.O. Drawer DD, Artesia, NM 88211-0719

District III
1000 Rio Brazos Rd., Aztec, NM 87410

District IV
PO Box 2088, Santa Fe, NM 87504-2088

State of New Mexico
Energy, Minerals, & Natural Resources Department

Form C-104
Revised February 21, 1994
Instructions on back
Submit to Appropriate District Office
5 Copies

OIL CONSERVATION DIVISION
PO Box 2088
Santa Fe, NM 87504-2088

AMMENDED REPORT

I. REQUEST FOR ALLOWABLE AND AUTHORIZATION TO TRANSPORT

¹ Operator Name and Address Burlington Resources Oil & Gas PO Box 4289 Farmington, NM 87499		² OGRID Number 14538
		³ Reason for Filing Code CO - 7/11/96
⁴ API Number 30-045-9385	⁵ Pool Name BLANCO MESAVERDE (PRORATED) GAS	⁶ Pool Code 72319
⁷ Property Code 007224	⁸ Property Name KING	⁹ Well Number #1

II. ¹⁰ Surface Location

UI or lot no.	Section	Township	Range	Lot.Idn	Feet from the	North/South Line	Feet from the	East/West Line	County
A	22	030N	010W		990	N	890	E	SAN JUAN

¹¹ Bottom Hole Location

UI or lot no.	Section	Township	Range	Lot.Idn	Feet from the	North/South Line	Feet from the	East/West Line	County
¹² Lse Code	¹³ Producing Method Code	¹⁴ Gas Connection Date	¹⁵ C-129 Permit Number	¹⁶ C-129 Effective Date	¹⁷ C-129 Expiration Date				

III. Oil and Gas Transporters

¹⁸ Transporter OGRID	¹⁹ Transporter Name and Address	²⁰ POD	²¹ O/G	²² POD ULSTR Location and Description
7057	EL PASO FIELD SERVICES P.O. BOX 1492 EL PASO, TX 79978		G	A-22-T030N-R010W
9018	Giant Industries 5764 US Hwy 64 Farmington, NM 87401	1602410	O	A-22-T030N-R010W

IV. Produced Water

²³ POD	²⁴ POD ULSTR Location and Description
-------------------	--

V. Well Completion Data

²⁵ Spud Date	²⁶ Ready Date	²⁷ TD	²⁸ PBDT	²⁹ Perforations
³⁰ Hole Size	³¹ Casing & Tubing Size	³² Depth Set	³³ Sacks Cement	

VI. Well Test Data

³⁴ Date New Oil	³⁵ Gas Delivery Date	³⁶ Test Date	³⁷ Test Length	³⁸ Tbg. Pressure	³⁹ Csg. Pressure
⁴⁰ Choke Size	⁴¹ Oil	⁴² Water	⁴³ Gas	⁴⁴ AOF	⁴⁵ Test Method

⁴⁶ I hereby certify that the rules of the Oil Conservation Division have been complied with and that the information given above is true and complete to the best of my knowledge and belief. Signature: <i>Dolores Diaz</i> Printed Name: Dolores Diaz Title: Production Associate Date: 7/11/96 Phone: (505) 326-9700	OIL CONSERVATION DIVISION			
	Approved by: Frank T. Chavez			
	Title: District Supervisor			
	Approved Date: July 11, 1996			
⁴⁷ If this is a change of operator fill in the OGRID number and name of the previous operator 14538 Meridian Oil Production				
Previous Operator Signature Signature: <i>Dolores Diaz</i>	Printed Name Dolores Diaz	Title Production Associate	Date 7/11/96	