

Carlsbad Field Office
HOBBS OCD
OCD Hobbs

FORM APPROVED
OMB No. 1004-0137
Expires October 31, 2014

JUN 13 2018

UNITED STATES
DEPARTMENT OF THE INTERIOR
BUREAU OF LAND MANAGEMENT

APPLICATION FOR PERMIT TO DRILL OR REENTER

RECEIVED

1a. Type of work: <input checked="" type="checkbox"/> DRILL <input type="checkbox"/> REENTER		5. Lease Serial No. NMNM093223	
1b. Type of Well: <input type="checkbox"/> Oil Well <input checked="" type="checkbox"/> Gas Well <input type="checkbox"/> Other <input checked="" type="checkbox"/> Single Zone <input type="checkbox"/> Multiple Zone		7. If Unit or CA Agreement, Name and No.	
2. Name of Operator MARATHON OIL PERMIAN LLC (372098)		8. Lease Name and Well No. (321518) MADERA 19 FEDERAL 28 35 19 6H	
3a. Address 5555 San Felipe St. Houston TX 77056		9. API Well No. 30-025 44902	
3b. Phone No. (include area code) (713)629-6600		10. Field and Pool, or Exploratory / WOLFCAMP; (98289)	
4. Location of Well (Report location clearly and in accordance with any State requirements.)* At surface SESW / 351 FSL / 1428 FWL / LAT 32.0224021 / LONG -103.41005 At proposed prod. zone NWSW / 2312 FSL / 1320 FWL / LAT 32.0423072 / LONG -103.4104023		11. Sec., T. R. M. or Blk. and Survey or Area SEC 19 / T26S / R35E / NMP	
14. Distance in miles and direction from nearest town or post office* 16 miles		12. County or Parish LEA	13. State NM
15. Distance from proposed* location to nearest property or lease line, ft. (Also to nearest drig. unit line, if any) 352 feet	16. No. of acres in lease 645.6	17. Spacing Unit dedicated to this well 485.6	
18. Distance from proposed location* to nearest well, drilling, completed, 400 feet applied for, on this lease, ft.	19. Proposed Depth 12682 feet / 19950 feet	20. BLM/BIA Bond No. on file FED: WYB002107	
21. Elevations (Show whether DF, KDB, RT, GL, etc.) 3266 feet	22. Approximate date work will start* 04/01/2018	23. Estimated duration 30 days	

24. Attachments

The following, completed in accordance with the requirements of Onshore Oil and Gas Order No. 1, must be attached to this form:

- Well plat certified by a registered surveyor.
- A Drilling Plan.
- A Surface Use Plan (if the location is on National Forest System Lands, the SUPO must be filed with the appropriate Forest Service Office).
- Bond to cover the operations unless covered by an existing bond on file (see Item 20 above).
- Operator certification
- Such other site specific information and/or plans as may be required by the BLM.

25. Signature (Electronic Submission)	Name (Printed/Typed) Jennifer Van Curen / Ph: (713)296-2500	Date 01/24/2018
Title Sr. Regulatory Compliance Rep		
Approved by (Signature) (Electronic Submission)	Name (Printed/Typed) Cody Layton / Ph: (575)234-5959	Date 06/11/2018
Title Supervisor Multiple Resources Office CARLSBAD		

Application approval does not warrant or certify that the applicant holds legal or equitable title to those rights in the subject lease which would entitle the applicant to conduct operations thereon.
Conditions of approval, if any, are attached.

Title 18 U.S.C. Section 1001 and Title 43 U.S.C. Section 1212, make it a crime for any person knowingly and willfully to make to any department or agency of the United States any false, fictitious or fraudulent statements or representations as to any matter within its jurisdiction.

(Continued on page 2)

*(Instructions on page 2)

ocp Rec 06/13/18

APPROVED WITH CONDITIONS
Approval Date: 06/11/2018

KZ
06/04/18

INSTRUCTIONS

GENERAL: This form is designed for submitting proposals to perform certain well operations, as indicated on Federal and Indian lands and leases for action by appropriate Federal agencies, pursuant to applicable Federal laws and regulations. Any necessary special instructions concerning the use of this form and the number of copies to be submitted, particularly with regard to local, area, or regional procedures and practices, either are shown below or will be issued by, or may be obtained from local Federal offices.

ITEM 1: If the proposal is to redrill to the same reservoir at a different subsurface location or to a new reservoir, use this form with appropriate notations. Consult applicable Federal regulations concerning subsequent work proposals or reports on the well.

ITEM 4: Locations on Federal or Indian land should be described in accordance with Federal requirements. Consult local Federal offices for specific instructions.

ITEM 14: Needed only when location of well cannot readily be found by road from the land or lease description. A plat, or plats, separate or on the reverse side, showing the roads to, and the surveyed location of, the well, and any other required information, should be furnished when required by Federal agency offices.

ITEMS 15 AND 18: If well is to be, or has been directionally drilled, give distances for subsurface location of hole in any present or objective productive zone.

ITEM 22: Consult applicable Federal regulations, or appropriate officials, concerning approval of the proposal before operations are started.

NOTICES

The Privacy Act of 1974 and regulation in 43 CFR 2.48(d) provide that you be furnished the following information in connection with information required by this application.

AUTHORITY: 30 U.S.C. 181 et seq., 25 U.S.C. 396; 43 CFR 3160

PRINCIPAL PURPOSES: The information will be used to: (1) process and evaluate your application for a permit to drill a new oil, gas, or service well or to reenter a plugged and abandoned well; and (2) document, for administrative use, information for the management, disposal and use of National Resource Lands and resources including (a) analyzing your proposal to discover and extract the Federal or Indian resources encountered; (b) reviewing procedures and equipment and the projected impact on the land involved; and (c) evaluating the effects of the proposed operation on the surface and subsurface water and other environmental impacts.

ROUTINE USE: Information from the record and/or the record will be transferred to appropriate Federal, State, and local or foreign agencies, when relevant to civil, criminal or regulatory investigations or prosecution, in connection with congressional inquiries and for regulatory responsibilities.

EFFECT OF NOT PROVIDING INFORMATION: Filing of this application and disclosure of the information is mandatory only if you elect to initiate a drilling or reentry operation on an oil and gas lease.

The Paperwork Reduction Act of 1995 requires us to inform you that:

The BLM collects this information to allow evaluation of the technical, safety, and environmental factors involved with drilling for oil and/or gas on Federal and Indian oil and gas leases. This information will be used to analyze and approve applications.

Response to this request is mandatory only if the operator elects to initiate drilling or reentry operations on an oil and gas lease.

The BLM would like you to know that you do not have to respond to this or any other Federal agency-sponsored information collection unless it displays a currently valid OMB control number.

BURDEN HOURS STATEMENT: Public reporting burden for this form is estimated to average 8 hours per response, including the time for reviewing instructions, gathering and maintaining data, and completing and reviewing the form. Direct comments regarding the burden estimate or any other aspect of this form to U.S. Department of the Interior, Bureau of Land Management (1004-0137), Bureau Information Collection Clearance Officer (WO-630), 1849 C Street, N.W., Mail Stop 401 LS, Washington, D.C. 20240.

Additional Operator Remarks

Location of Well

1. SHL: SESW / 351 FSL / 1428 FWL / TWSP: 26S / RANGE: 35E / SECTION: 19 / LAT: 32.0224021 / LONG: -103.41005 (TVD: 0 feet, MD: 0 feet)
PPP: NWNW / 0 FNL / 1320 FWL / TWSP: 26S / RANGE: 35E / SECTION: 18 / LAT: 32.0359519 / LONG: -103.4104019 (TVD: 12682 feet, MD: 17638 feet)
PPP: SWSW / 330 FSL / 1320 FWL / TWSP: 26S / RANGE: 35E / SECTION: 18 / LAT: 32.0223449 / LONG: -103.4106998 (TVD: 12569 feet, MD: 12659 feet)
BHL: NWSW / 2312 FSL / 1320 FWL / TWSP: 26S / RANGE: 35E / SECTION: 18 / LAT: 32.0423072 / LONG: -103.4104023 (TVD: 12682 feet, MD: 19950 feet)

BLM Point of Contact

Name: Priscilla Perez

Title: Legal Instruments Examiner

Phone: 5752345934

Email: pperez@blm.gov

CONFIDENTIAL

Review and Appeal Rights

A person contesting a decision shall request a State Director review. This request must be filed within 20 working days of receipt of the Notice with the appropriate State Director (see 43 CFR 3165.3). The State Director review decision may be appealed to the Interior Board of Land Appeals, 801 North Quincy Street, Suite 300, Arlington, VA 22203 (see 43 CFR 3165.4). Contact the above listed Bureau of Land Management office for further information.

CONFIDENTIAL



APD ID: 10400026517

Submission Date: 01/24/2018



Operator Name: MARATHON OIL PERMIAN LLC

Well Name: MADERA 19 FEDERAL 26 35 19 WXY

Well Number: 6H

[Show Final Text](#)

Well Type: CONVENTIONAL GAS WELL

Well Work Type: Drill

Section 1 - General

APD ID: 10400026517

Tie to previous NOS?

Submission Date: 01/24/2018

BLM Office: CARLSBAD

User: Jennifer Van Curen

Title: Sr. Regulatory Compliance Rep

Federal/Indian APD: FED

Is the first lease penetrated for production Federal or Indian? FED

Lease number: NMNM093223

Lease Acres: 645.6

Surface access agreement in place?

Allotted?

Reservation:

Agreement in place? NO

Federal or Indian agreement:

Agreement number:

Agreement name:

Keep application confidential? YES

Permitting Agent? NO

APD Operator: MARATHON OIL PERMIAN LLC

Operator letter of designation:

Operator Info

Operator Organization Name: MARATHON OIL PERMIAN LLC

Operator Address: 5555 San Felipe St.

Zip: 77056

Operator PO Box:

Operator City: Houston

State: TX

Operator Phone: (713)629-6600

Operator Internet Address:

Section 2 - Well Information

Well in Master Development Plan? NO

Mater Development Plan name:

Well in Master SUPO? NO

Master SUPO name:

Well in Master Drilling Plan? NO

Master Drilling Plan name:

Well Name: MADERA 19 FEDERAL 26 35 19 WXY

Well Number: 6H

Well API Number:

Field/Pool or Exploratory? Field and Pool

Field Name: JABALINA

Pool Name: WOLFCAMP;
SOUTHWEST

Is the proposed well in an area containing other mineral resources? USEABLE WATER

Operator Name: MARATHON OIL PERMIAN LLC

Well Name: MADERA 19 FEDERAL 26 35 19 WXY

Well Number: 6H

Describe other minerals:

Is the proposed well in a Helium production area? N Use Existing Well Pad? NO New surface disturbance?

Type of Well Pad: MULTIPLE WELL

Multiple Well Pad Name: Number: 363-1

MADERA 19 FEDERAL 26 35 19

Well Class: HORIZONTAL

Number of Legs: 1

Well Work Type: Drill

Well Type: CONVENTIONAL GAS WELL

Describe Well Type:

Well sub-Type: INFILL

Describe sub-type:

Distance to town: 16 Miles

Distance to nearest well: 400 FT

Distance to lease line: 352 FT

Reservoir well spacing assigned acres Measurement: 485.6 Acres

Well plat: 20180119_R3817_004_MADERA_19_FEDERAL_26_35_19_WXY_6H_REV2_CERTIFIED_FORM_C_1
02_20180430122817.pdf

Well work start Date: 04/01/2018

Duration: 30 DAYS

Section 3 - Well Location Table

Survey Type: RECTANGULAR

Describe Survey Type:

Datum: NAD27

Vertical Datum: NAVD88

Survey number: R3817

	NS-Foot	NS Indicator	EW-Foot	EW Indicator	Twsp	Range	Section	Aliquot/Lot/Tract	Latitude	Longitude	County	State	Meridian	Lease Type	Lease Number	Elevation	MD	TVD
SHL Leg #1	351	FSL	1428	FWL	26S	35E	19	Aliquot SESW	32.0224021	-103.41005	LEA	NEW MEXI CO	NEW MEXI CO	F	NMNM 093223	3266	0	0
KOP Leg #1	100	FSL	1320	FWL	26S	35E	19	Aliquot SWSW	32.0217175	-103.4103989	LEA	NEW MEXI CO	NEW MEXI CO	F	NMNM 093223	-8843	12125	12109
PPP Leg #1	330	FSL	1320	FWL	26S	35E	18	Aliquot SWSW	32.0223449	-103.4106998	LEA	NEW MEXI CO	NEW MEXI CO	F	NMNM 093223	-9303	12659	12569

APD ID: 10400026517

Submission Date: 01/24/2018

Highlighted data reflects the most recent changes

Operator Name: MARATHON OIL PERMIAN LLC

Well Name: MADERA 19 FEDERAL 26 35 19 WXY

Well Number: 6H

Show Final Text

Well Type: CONVENTIONAL GAS WELL

Well Work Type: Drill

Section 1 - Geologic Formations

Formation ID	Formation Name	Elevation	True Vertical Depth	Measured Depth	Lithologies	Mineral Resources	Producing Formation
1	RUSTLER	2227	1039	1039	DOLOMITE, ANHYDRITE	OTHER : Brine	No
2	SALADO	1776	1490	1490	SALT, ANHYDRITE	OTHER : Brine	No
3	CASTILE	-298	3564	3566	SALT	OTHER : Brine	No
4	BASE OF SALT	-1925	5191	5207	LIMESTONE, SANDSTONE	OTHER : Brine	No
5	LAMAR	-2064	5330	5346	SHALE, SANDSTONE	OIL	No
6	BELL CANYON	-2090	5356	5372	SHALE, SANDSTONE	OIL	No
7	CHERRY CANYON	-3390	6656	6672	SANDSTONE, OTHER : Carbonate	OIL	No
8	BRUSHY CANYON	-4554	7820	7836	SANDSTONE, OTHER : Carbonate	OIL	No
9	BONE SPRING	-6006	9272	9288	SANDSTONE, OTHER : Carbonate	OIL	No
10	BONE SPRING 1ST	-7337	10603	10619	SANDSTONE, OTHER : Carbonate	OIL	No
11	BONE SPRING 2ND	-7850	11116	11132	SANDSTONE, OTHER : Carbonate	OIL	No
12	BONE SPRING 3RD	-8908	12174	12190	SANDSTONE, OTHER : Carbonates	OIL	No
13	WOLFCAMP	-9310	12576	12671	SHALE, SANDSTONE, OTHER : Carbonate	OIL	Yes

Section 2 - Blowout Prevention

Operator Name: MARATHON OIL PERMIAN LLC

Well Name: MADERA 19 FEDERAL 26 35 19 WXY

Well Number: 6H

Pressure Rating (PSI): 5M

Rating Depth: 15152

Equipment: 13 5/8 Annular, blind, and Double Ram will be installed and tested for each of the 12 1/4, 8 3/4, and 6 1/8 casing strings.

Requesting Variance? YES

Variance request: A variance is requested for the use of a flexible choke line from the BOP to Choke Manifold. See attached for specs and hydrostatic test chart.

Testing Procedure: - BOP/BOPE will be tested by an independent service company to 250 pps and 90% of the working pressure for the high pressure per Onshore Order 2 requirements. The System may be upgraded to a higher pressure but still tested to the working pressure listed in the table above. If the system is upgraded all the components installed will be operational and tested. - Pipe rams will be operationally checked each 24 hour period. Blind rams will be operationally checked on each trip out of the hole. These checks will be noted on the daily tour sheets. Other accessories to the BOP equipment will include a Kelly sock, full opening safety valve inside BOP and choke lines and choke manifold. See attached schematic. - Function integrity test will be performed per Onshore Order #2. On Exploratory well or on that portion of any well approved for a 5M BOPE system or greater, a pre-emptive integrity test and tubing check shall be performed. Will be run in accordance with Onshore Order #2 and Gas Order #2 MBE 11. - A 5/8" ID wellhead tubing head on all BOP will be tested per Onshore Order #2. If the regulator on the surface casing which will cover testing equipment is not a minimum of 20' deep. If any well subject to test pressure is broken the system will be tested. See attached schematic.

Choke Diagram Attachment:

5M_10M.TWO_CHOKE_MANIFOLD.BLM_20180123093800.pdf

Choke_Line_Flex_III_Rig_20180123093801.pdf

Choke_Line_Test_Chart_SN_63393_20180123093802.pdf

Contitech_Hose_SN_663393_20180430122921.pdf

BOP Diagram Attachment:

5M_Flex.BOPE.BLM_20180123095547.pdf

WH_TH_Design_1B_5K_10K_7in_x_4.5in_20180123093944.pdf

Section 3 - Casing

Casing ID	String Type	Hole Size	Csg Size	Condition	Standard	Tapered String	Top Set MD	Bottom Set MD	Top Set TVD	Bottom Set TVD	Top Set MSL	Bottom Set MSL	Calculated casing length MD	Grade	Weight	Joint Type	Collapse SF	Burst SF	Joint SF Type	Joint SF	Body SF Type	Body SF
1	SURFACE	17.5	13.375	NEW	API	N	0	1050	0	1050	3266	2216	1050	J-55	54.5	STC	1.125	1.125	BUOY	1.8	BUOY	1.8
2	INTERMEDIATE	12.25	9.625	NEW	API	N	0	5400	0	5330	3331	-1999	5400	J-55	40	OTHER - BTC	1.125	1.125	BUOY	1.8	BUOY	1.8
3	PRODUCTION	8.75	7.0	NEW	API	N	0	12750	0	12600	3331	-9269	12750	P-110	29	OTHER - BTC	1.125	1.125	BUOY	1.8	BUOY	1.8
4	LINER	6.125	4.5	NEW	API	N	12050	19950	12000	12682	-8819	-9430	7900	P-110	13.5	OTHER - BTC	1.125	1.125	BUOY	1.8	BUOY	1.8

Operator Name: MARATHON OIL PERMIAN LLC

Well Name: MADERA 19 FEDERAL 26 35 19 WXY

Well Number: 6H

Casing Attachments

Casing ID: 1 **String Type:** SURFACE

Inspection Document:

Spec Document:

Tapered String Spec:

Casing Design Assumptions and Worksheet(s):

Red_Hills_3_csg__liner__Surface_Csg_20180123114238.pdf

Casing ID: 2 **String Type:** INTERMEDIATE

Inspection Document:

Spec Document:

Tapered String Spec:

Casing Design Assumptions and Worksheet(s):

Red_Hills_3_csg__liner__Int_I_Csg_20180123114250.pdf

Casing ID: 3 **String Type:** PRODUCTION

Inspection Document:

Spec Document:

Tapered String Spec:

Casing Design Assumptions and Worksheet(s):

Red_Hills_3_csg__liner__Int_II_Csg_20180123114302.pdf

Operator Name: MARATHON OIL PERMIAN LLC

Well Name: MADERA 19 FEDERAL 26 35 19 WXY

Well Number: 6H

Casing Attachments

Casing ID: 4 String Type:LINER

Inspection Document:

Spec Document:

Tapered String Spec:

Casing Design Assumptions and Worksheet(s):

Red_Hills_3_csg__liner__Prod_Liner_20180123100445.pdf

Section 4 - Cement

String Type	Lead/Tail	Stage Tool Depth	Top MD	Bottom MD	Quantity(sx)	Yield	Density	Cu Ft	Excess%	Cement type	Additives
SURFACE	Lead		0	840	668	1.75	13.5	1167	100	Class C	3 lbm/sk granular LCM + 0.1250 lbm/sk Poly-EFlake
SURFACE	Tail		840	1050	214	1.36	14.8	292	100	Class C	0.25 % Accelerator
PRODUCTION	Lead		0	4320	1369	1.73	12.8	2368	75	Class C	0.02 Gal/Sx Defoamer + 0.5% Extender + 1% Accelerator
PRODUCTION	Tail		4320	5400	381	1.33	14.8	507	50	Class C	0.07 % Retarder
INTERMEDIATE	Lead		5000	1175 0	639	2.7	11	1725	70	Class C	0.8% retarder + 10% extender + 0.02 gal/sk + 2.0% Extender + 0.15% Viscosifier
INTERMEDIATE	Tail		1175 0	1275 0	179	1.09	15.6	195	30	Class H	3% extender + 0.1% Dispersant + 0.2% retarder
LINER	Lead		1205 0	1995 0	0	0	0	0	0	No lead cement, tail only.	0
LINER	Tail		1205 0	1995 0	793	1.22	14.5	967	30	Class H	0.15% retarder + 3.5% extender + 0.25% fluid loss

Operator Name: MARATHON OIL PERMIAN LLC

Well Name: MADERA 19 FEDERAL 26 35 19 WXY

Well Number: 6H

Section 5 - Circulating Medium

Mud System Type: Closed

Will an air or gas system be Used? NO

Description of the equipment for the circulating system in accordance with Onshore Order #2:

Diagram of the equipment for the circulating system in accordance with Onshore Order #2:

Describe what will be on location to control well or mitigate other conditions: The necessary mud products for additional weight and fluid loss control will be on location at all times.

Describe the mud monitoring system utilized: Losses or gains in the mud system will be monitored visually/manually as well as with an electronic PVT.

Circulating Medium Table

Top Depth	Bottom Depth	Mud Type	Min Weight (lbs/gal)	Max Weight (lbs/gal)	Density (lbs/cu ft)	Gel Strength (lbs/100 sqft)	PH	Viscosity (CP)	Salinity (ppm)	Filtration (cc)	Additional Characteristics
1050	5400	SALT SATURATED	9.9	10.2							
0	1050	WATER-BASED MUD	8.4	8.8							
1275 0	1995 0	OIL-BASED MUD	12	12.5							
5400	1275 0	OTHER : Cut Brine	9	9.4							

Section 6 - Test, Logging, Coring

List of production tests including testing procedures, equipment and safety measures:

- A Kelly cock will be in the drill string at all times.
- A full opening drill pipe stabbing valve having the appropriate connections will be on the rig floor unobstructed and readily accessible at all times.
- Hydrogen Sulfide detection equipment will be in operation after drilling out the surface casing shoe until the production casing is cemented. Breathing equipment will be on location upon drilling the surface casing shoe until total depth is reached. If Hydrogen Sulfide is encountered , measured amounts and formations will be reported to the BLM

List of open and cased hole logs run in the well:

GR

Operator Name: MARATHON OIL PERMIAN LLC

Well Name: MADERA 19 FEDERAL 26 35 19 WXY

Well Number: 6H

Coring operation description for the well:

- D. DST's: None.
- E. Open Hole Logs: GR while drilling from Intermediate I casing shoe to TD.

Section 7 - Pressure

Anticipated Bottom Hole Pressure: 7609

Anticipated Surface Pressure: 4818.96

Anticipated Bottom Hole Temperature(F): 190

Anticipated abnormal pressures, temperatures, or potential geologic hazards? NO

Describe:

Contingency Plans geohazards description:

Contingency Plans geohazards attachment:

Hydrogen Sulfide drilling operations plan required? YES

Hydrogen sulfide drilling operations plan:

Marathon_Carlsbad__Madera_19_FED26_35_19_1H_2H_5H_6H_Contingency_Plan_011518_20180123100807.pdf
H2S_Preparedness_and_Contingency_Plan_20180123100953.pdf
Pad_Flex_III_20180430123146.pdf

Section 8 - Other Information

Proposed horizontal/directional/multi-lateral plan submission:

Madera_19_Federal_WXY_6H_Directional_Plan_20180124061722.pdf

Other proposed operations facets description:

Potential Hazards:

- H2S detection equipment will be in operation after drilling out the surface casing shoe until the production casing has been cemented. Breathing equipment will be on location from drilling out the surface shoe until production casing is cemented. If H2S is encountered the operator will comply with Onshore Order #6.
- No abnormal temperatures or pressures are anticipated. All personnel will be familiar with all aspects of safe operation of equipment being used to drill this well. Adequate flare lines will be installed off the mud/gas separator where gas may be flared safely.
- No losses are anticipated at this time.
- All personnel will be familiar with all aspects of safe operation of equipment being used to drill this well.
- Adequate flare lines will be installed off the mud/gas separator where gas may be flared safely.

Other proposed operations facets attachment:

Madera_19_Federal_WXY_6H_Drilling_APD_Information_20180124061801.pdf
Batch_Drilling_Plan_and_Surface_Rig_Request_20180516112309.pdf

Other Variance attachment:

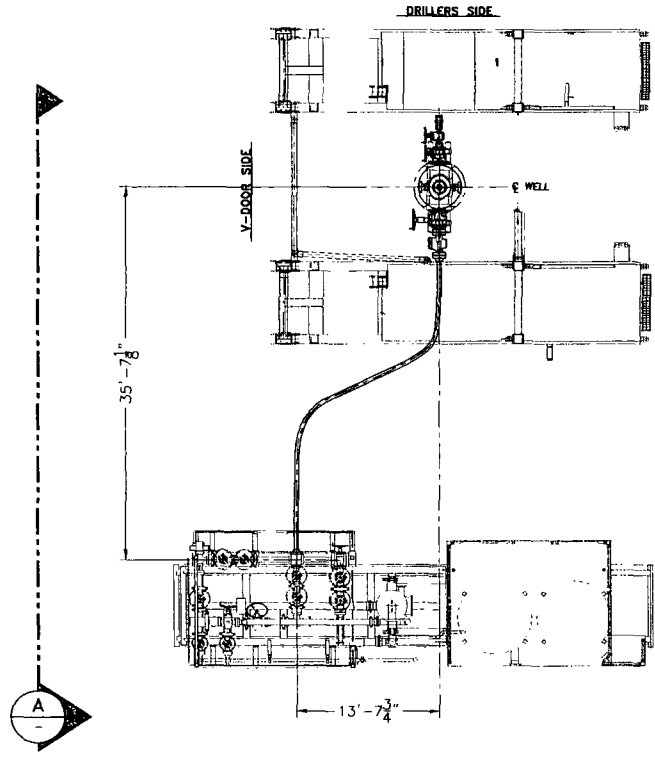

PLAN VIEW

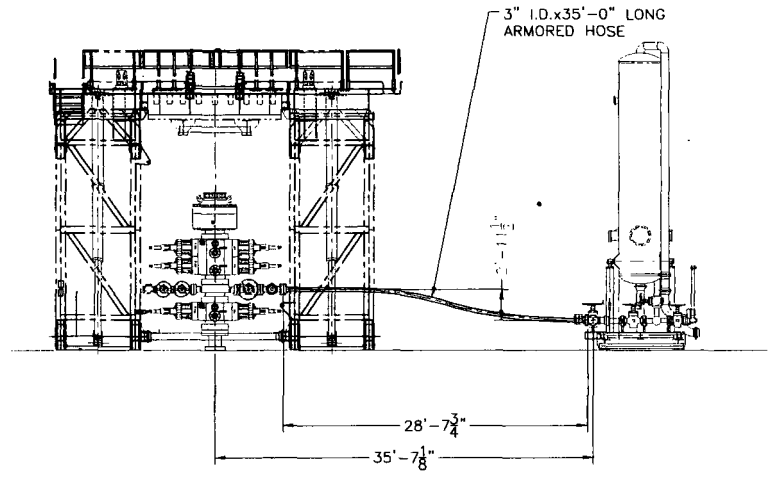

SECTION "A"

ISSUED FOR FABRICATION
 December-19-2007
 DRAFTSMAN _____
 ENGINEER _____

PROPRIETARY
 THIS DRAWING AND THE IDEAS AND INFORMATION INCLUDED IN THIS DRAWING ARE PROPRIETARY AND ARE NOT TO BE REPRODUCED, DISTRIBUTED OR DISCLOSED IN ANY MANNER WITHOUT THE PRIOR, WRITTEN CONSENT OF A DULY AUTHORIZED OFFICER OF HELMERRICH & PAYNE INT'L DRILLING CO.

REV	DATE	DESCRIPTION	BY
▲			
▲			
▲			
▲	12/18/07	REMOVED SHEET TOTAL CALLOUT	JAV

HELMERRICH & PAYNE INTERNATIONAL DRILLING CO.

ENGINEERING APPROVAL		DATE	TITLE:
			CHOKE LINE SYSTEM FLEXRIG3
CUSTOMER:			
PROJECT:			
DRAWN:	JBG	DATE:	4-10-07
ENG. NO.:		SCALE:	3/16"=1'
REV:		SHEET:	2 OF 3
			210-P1-07 A

Certificate of Conformity

ContiTech

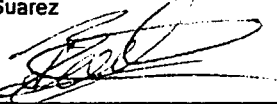
Certificate Number 953233-4	COM Order Reference 953233	Customer Name & Address HELMERICH & PAYNE DRILLING CO 1434 SOUTH BOULDER AVE TULSA, OK 74119 USA	
Customer Purchase Order No: 740053080			
Project:			
Test Center/Address		Accepted by GOM Inspection	
ContiTech Oil & Marine Corp. 11535 Brittmoore Park Drive Houston, TX 77041 USA		Signed: Roger Suarez  Date: 5/11/17	
		Accepted by Client Inspection	

We certify that the items detailed below meet the requirements of the customer's Purchase Order referenced above, and are in conformance with the specifications given below.

Item	Part No.	Description	Qty	Serial Number	Specifications
30		RECERTIFICATION - 3" ID 10K Choke and Kill Hose x 35 ft OAL	1	63393	ContiTech Standard

Hydrostatic Test Certificate

ContiTech

Certificate Number 953233-4	COM Order Reference 953233	Customer Name & Address HELMERICH & PAYNE DRILLING CO 1434 SOUTH BOULDER AVE TULSA, OK 74119 USA	
Customer Purchase Order No: 740053080			
Project:			
Treat Center Address ContiTech Oil & Marine Corp. 11535 Brittmoore Park Drive Houston, TX 77041 USA	Accepted by COM Inspection Signed: Roger Suarez Date: 5/11/17	Accepted by Client Inspection	

We certify that the goods detailed hereon have been inspected as described below by our Quality Management System, and to the best of our knowledge are found to conform the requirements of the above referenced purchase order as issued to ContiTech Oil & Marine Corporation.

Item	Part No.	Description	Qty	Serial Number	Work Press	Test Press	Test Time (minutes)
30		RECERTIFICATION - 3" ID 10K Choke and Kill Hose x 35 ft OAL	1	63393	10,000 psi	15,000 psi	60

63393

6 AM

JOB# 46-20-1081
 PBC# 955237
 HOSE DESCRIPTION: 3" ID. 100' Chlor. 671
 TEST PRESSURE: 1500 PSI
 CHART RECORDER #: 94101
 CHART SETTING: 911
 CBC REPRESENTATIVE: Steve Fisher
 DATE: 5-5-70



CHART NO. MC MP-20000-150F
 METER

CHART PUT ON

LOCATION

REMARKS

TAKEN UP

NOON

6 PM

4

QUALITY CONTROL	No.: QC-DB- 380 / 2012
	Page : 1 / 61
Hose No.: 63389, 63390, 63391 63392, 63393	Revision : 0
	Date: 28. August 2012.
	Prepared by : <i>Szabolcs Lember</i>
	Appr. by: <i>Szabolcs Lember</i>

CHOKER AND KILL HOSES

id.: 3" 69 MPa x 35 ft (10,67 m)

DATA BOOK

Purchaser: H & P

Purchaser Order No.:

ContiTech Rubber Order No.: 531895

ContiTech Beattie Co. Order No.: 006227

NOT DESIGNED FOR WELL TESTING

CONTENT

		<u>Page</u>
1.	API QMS Certificate (No.: 0760)	3.
2.	American Petroleum Institute Certificate of Authority To Use the Official API Monogram (No.: 16C-0004)	4.
3.	Quality Control Inspection and Test Certificates (No.: 1595, 1596, 1597, 1598, 1599)	5-9.
4.	Hose Data Sheet	10.
5.	Metal Parts	
5.1.	Raw Material Quality Certificates (No.: EUR-240960, EUR-251871, 81687/12-0)	11-14.
5.2.	Hardness Test Reports (No.: HB 2150/12, HB 2151/12, HB 2159/12)	15-17.
5.3.	Ultrasonic Test Reports (No.: U12/124, U12/126, U12/129, U12/127)	18-21.
5.4.	NDT Examiner Certificate (Name: Joó Imre)	22-23.
5.5.	Welding Procedure Specification (No.: 140-60)	24-27.
5.6.	Welding Procedure Qualification Record (No.: BUD 0600014/1)	28-29.
5.7.	Welder's Approval Test Certificates (No.: RK-1894628-A1-X2, RK-1894628-A1-X-1, RK-2096656-B, RK-1894628-A1-X3, RK1079715-A1-X)	30-41.
5.8.	Welding Log Sheets (No.: 240, 241)	42-43.
5.9.	Visual Examination Record (No.: 696/12)	44.
5.10.	NDT Examiner Certificate (Name: Benkő Péter)	45-46.
5.11.	Radiographic Test Certificates (No.: 1458/12, 1459/12, 1460/12, 1461/12, 1462/12)	47-51.
5.12.	NDT Examiner Certificate (Name: Ménesi István)	52-53.
5.13.	MP Examination Record (No.: 1262/12)	54.
5.14.	NDT Examiner Certificate (Name: Oravecz Gábor)	55-56.
6.	Steel Cord	
6.1.	Inspection Certificate (No.: 437089)	57.
7.	Outside Stripwound Tube	
7.1.	Inspection Certificate (No.: 917781/001)	58.
8.	Certificate of Calibration (Manometer Serial No.: 0227-073)	59-61.



 ContiTech Rubber
 Industrial Kft.
 Quality Control Dept.
 (1)



Certificate of Registration

APIQR REGISTRATION NUMBER
0760

This certifies that the quality management system of
CONTITECH RUBBER INDUSTRIAL LTD.
Budapesti ut 10
Szeged
Hungary

*has been assessed by the American Petroleum Institute Quality Registrar (APIQR®) and
found it to be in conformance with the following standard:*

ISO 9001:2008

The scope of this registration and the approved quality management system applies to the
Design and Manufacture of High Pressure Hoses

APIQR® approves the organization's justification for excluding:
No Exclusions Identified as Applicable

COPY

Effective Date: October 15, 2010
Expiration Date: October 15, 2013
Registered Since: October 15, 2007

W. Dan Whittaker
Manager of Operations, APIQR

Accredited by Member of
the International
Accreditation For an
Mutual Recognition
Arrangement for Quality
Management Systems



This certificate is valid for the period specified herein. The registered organization must continually meet all requirements of APIQR's Registration Program and the requirements of the Registration Agreement. Registration is maintained and regularly monitored through annual full system audits. Further clarifications regarding the scope of this certificate and the applicability of ISO 9001 standard requirements may be obtained by consulting the registered organization. This certificate has been issued from APIQR offices located at 1220 L Street, N.W., Washington, D.C. 20004-4070, U.S.A. It is the property of APIQR, and must be returned upon request. To verify the authenticity of this certificate, go to www.apiqr.org/compositelst.



2007-10-15/2013-10-15

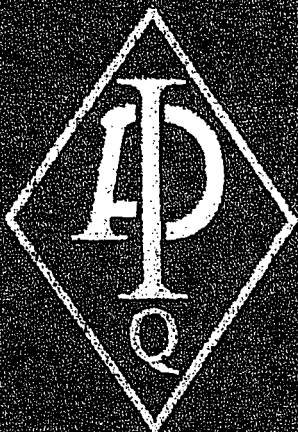

**American
Petroleum
Institute**



Certificate of Authority to use the Official API Monogram

License Number: 16C-0004

ORIGINAL

The American Petroleum Institute hereby grants to

CONTITECH RUBBER INDUSTRIAL LTD.

Budapesti ut 10

Szeged

Hungary

the right to use the Official API Monogram® on manufactured products under the conditions in the official publications of the American Petroleum Institute entitled API Spec Q1® and API Spec 16C and in accordance with the provisions of the License Agreement.

In all cases where the Official API Monogram is applied, the API Monogram should be used in conjunction with this certificate number: 16C-0004

The American Petroleum Institute reserves the right to revoke this authorization to use the Official API Monogram for any reason satisfactory to the Board of Directors of the American Petroleum Institute.

The scope of this license includes the following product: Flexible Choke and Kill Lines

QMS Exclusions: No Exclusions Identified as Applicable

COPY

Effective Date: OCTOBER 15, 2010

Expiration Date: OCTOBER 15, 2013

To verify the authenticity of this license, go to www.api.org/compositelst.

American Petroleum Institute

Director of Global Industry Services

CONTITECH RUBBER
Industrial Kft.

No: QC-DB- 380 /2012
Page: 4 /61

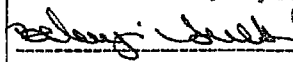
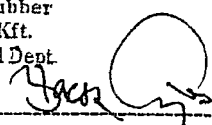
QUALITY CONTROL INSPECTION AND TEST CERTIFICATE				CERT. N°: 1599	
PURCHASER: ContiTech Beattie Co.			P.O. N°: 006227		
CONTITECH ORDER N°: 531895		HOSE TYPE: 3" ID		Choke and Kill Hose	
HOSE SERIAL N°: 63393		NOMINAL / ACTUAL LENGTH: 10,67 m / 10,72 m			
W.P. 68,9 MPa 10000 psi		T.P. 103,4 MPa 15000 psi		Duration: 60 min.	
<p>Pressure test with water at ambient temperature</p> <p style="text-align: center;">See attachment. (1 page)</p> <p>↑ 10 mm = 10 Min. → 10 mm = 20 MPa</p>					
COUPLINGS Type		Serial N°		Quality	
3" coupling with		2156 2153		AISI 4130	
4 1/16" 10K API Flange end				AISI 4130	
NOT DESIGNED FOR WELL TESTING				API Spec 16 C	
				Temperature rate:"B"	
All metal parts are flawless					
WE CERTIFY THAT THE ABOVE HOSE HAS BEEN MANUFACTURED IN ACCORDANCE WITH THE TERMS OF THE ORDER INSPECTED AND PRESSURE TESTED AS ABOVE WITH SATISFACTORY RESULT.					
STATEMENT OF CONFORMITY: We hereby certify that the above items/equipment supplied by us are in conformity with the terms, conditions and specifications of the above Purchaser Order and that these items/equipment were fabricated inspected and tested in accordance with the referenced standards, codes and specifications and meet the relevant acceptance criteria and design requirements.					
COUNTRY OF ORIGIN HUNGARY/EU					
Date: 23. August 2012.		Inspector		Quality Control ContiTech Rubber Industrial Kft. Quality Control Dept. (1)	
				 	



Hose Data Sheet

CR1 Order No.	531895
Customer	ContiTech Beattie Co.
Customer Order No	PO6227 Pbc13080-H&P
Item No.	1
Hose Type	Flexible Hose
Standard	API SPEC 16 C
Inside dia in inches	3
Length	35 ft
Type of coupling one end	FLANGE 4 1/16" API SPEC 6A TYPE 6BX FOR 10000 PSI C/W BX155RING GROOVE
Type of coupling other end	FLANGE 4 1/16" API SPEC 6A TYPE 6BX FOR 10000 PSI C/W BX155 RING GROOVE
H2S service NACE MR0175	Yes
Working Pressure	10 000 psi
Design Pressure	10 000 psi
Test Pressure	15 000 psi
Safety Factor	2,25
Marking	USUAL PHOENIX
Cover	NOT FIRE RESISTANT
Outside protection	St. steel outer wrap
Internal stripwound tube	No
Lining	OIL RESISTANT
Safety clamp	No
Lifting collar	No
Element C	No
Safety chain	No
Safety wire rope	No
Max. design temperature [°C]	100
Min. design temperature [°C]	-20
MBR operating [m]	1,60
MBR storage [m]	1,40
Type of packing	WOODEN CRATE ISPM-15

Operator: **Marathon Oil**
5M BOPE

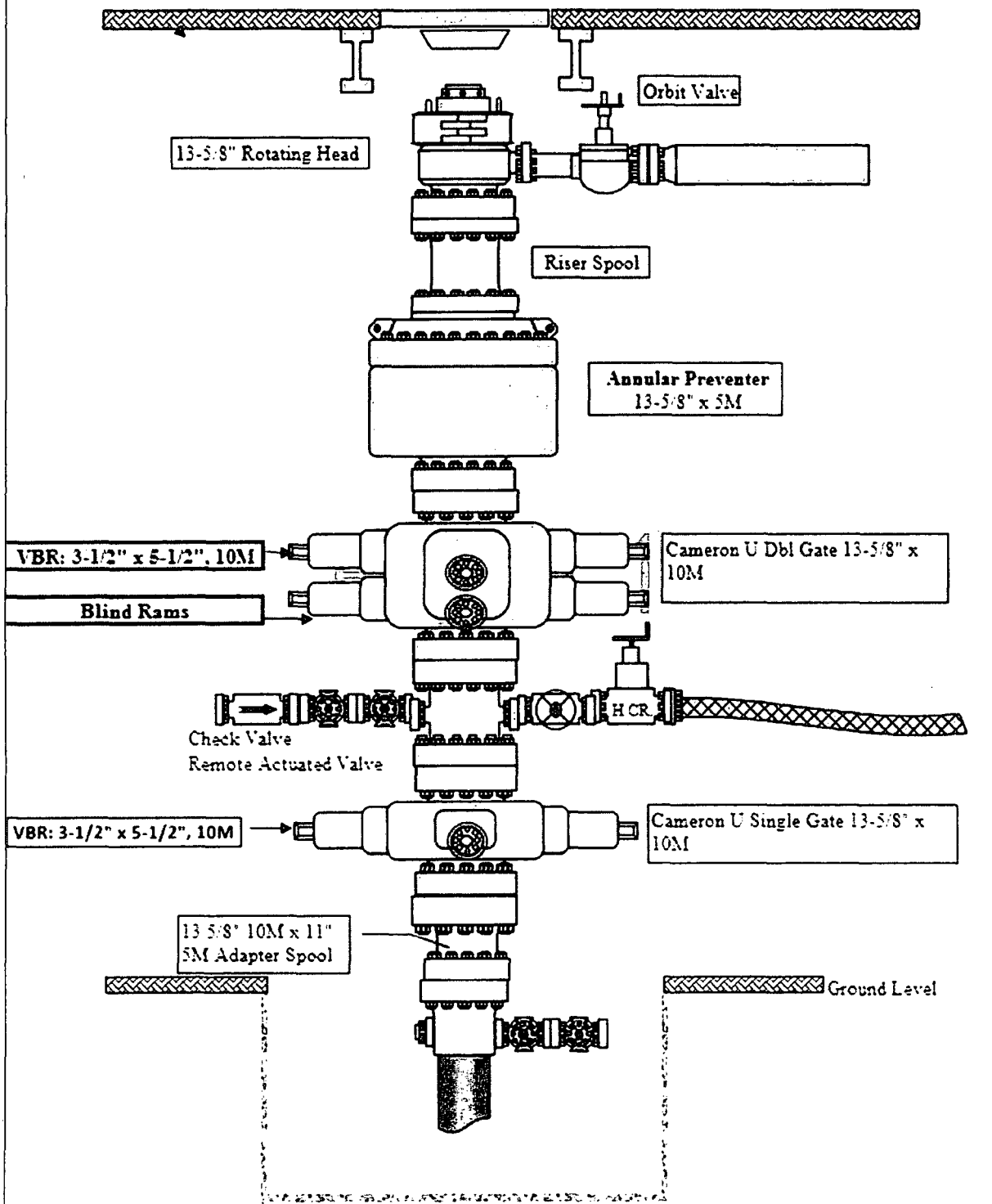

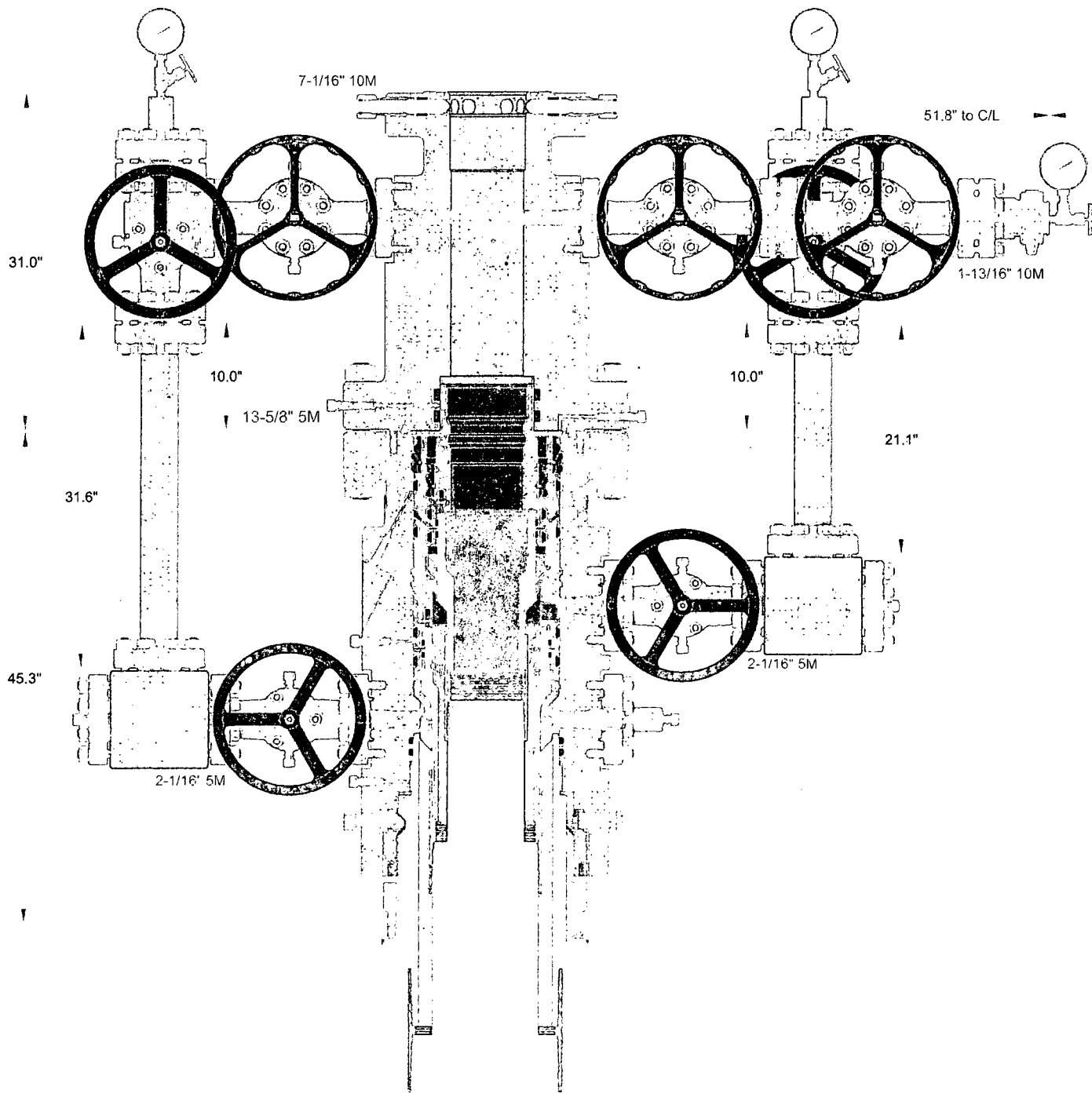

20" Conductor Pipe

13-3/8" Casing

9-5/8" Casing

7" Casing

INFORMATION CONTAINED HEREIN IS THE PROPERTY OF CACTUS WELLHEAD, LLC. REPRODUCTION, DISCLOSURE, OR USE THEREOF IS PERMISSIBLE ONLY AS PROVIDED BY CONTRACT OR AS EXPRESSLY AUTHORIZED BY CACTUS WELLHEAD, LLC.

CACTUS WELLHEAD LLC

MARATHON OIL COMPANY

20" x 13-3/8" x 9-5/8" x 7" MBU-3T-CFL-R-DBLO Wellhead
 With 13-5/8" 5M x 7-1/16" 10M CTH-DBLHPS Tubing Head (31" LG)
 Utilizing Pin Down Mandrel Casing Hangers

DRAWN	DLE	24JUL17
APPRV		
DRAWING NO.	ODE0001624	

Design Limits (13 3/8" Surface Casing - Section 1)

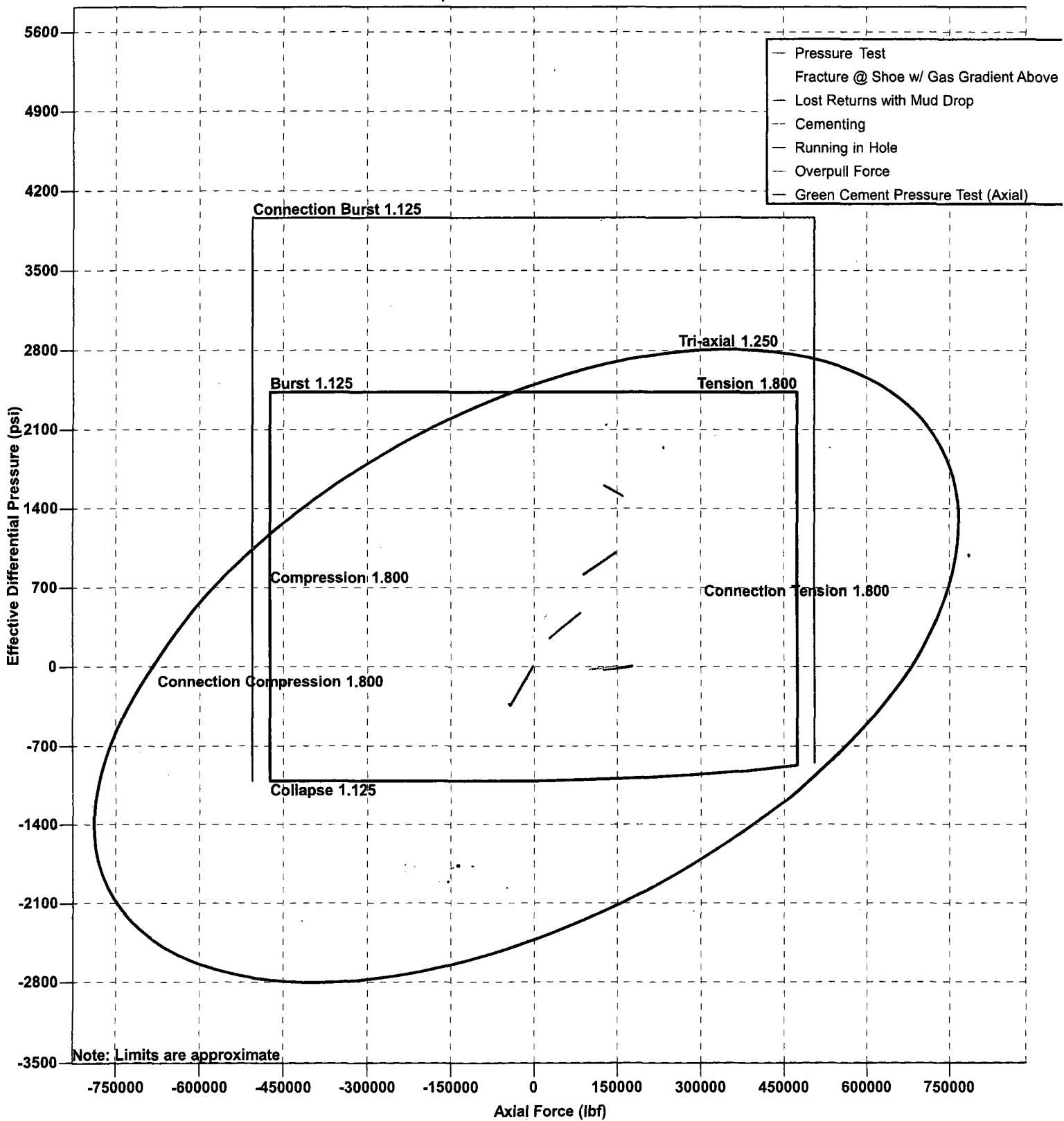

Design Limits (4 1/2" Production Liner - Section 1)

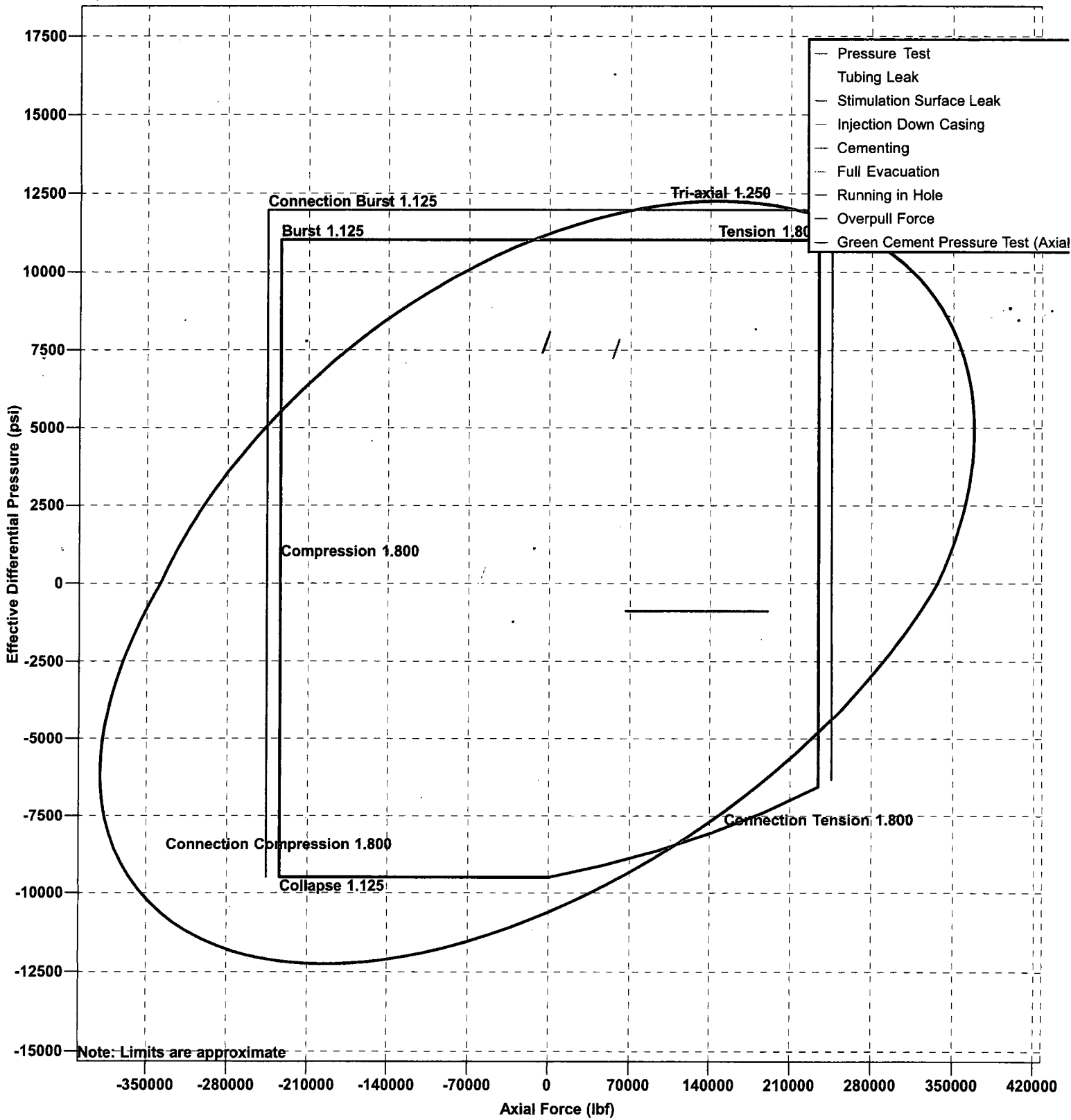

Design Limits (9 5/8" Intermediate Casing - Section 1)

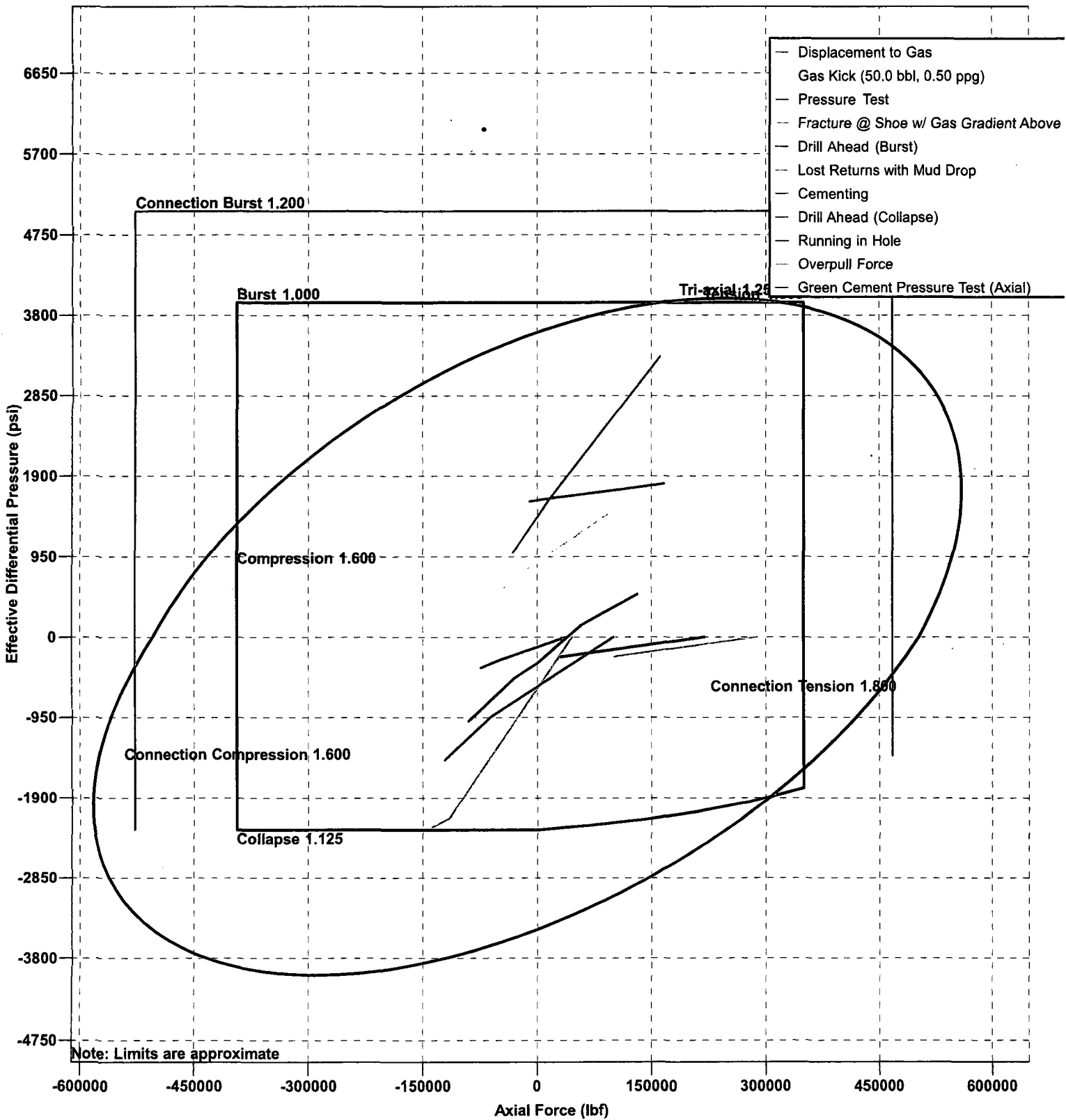

Design Limits (7" Production Casing - Section 1)

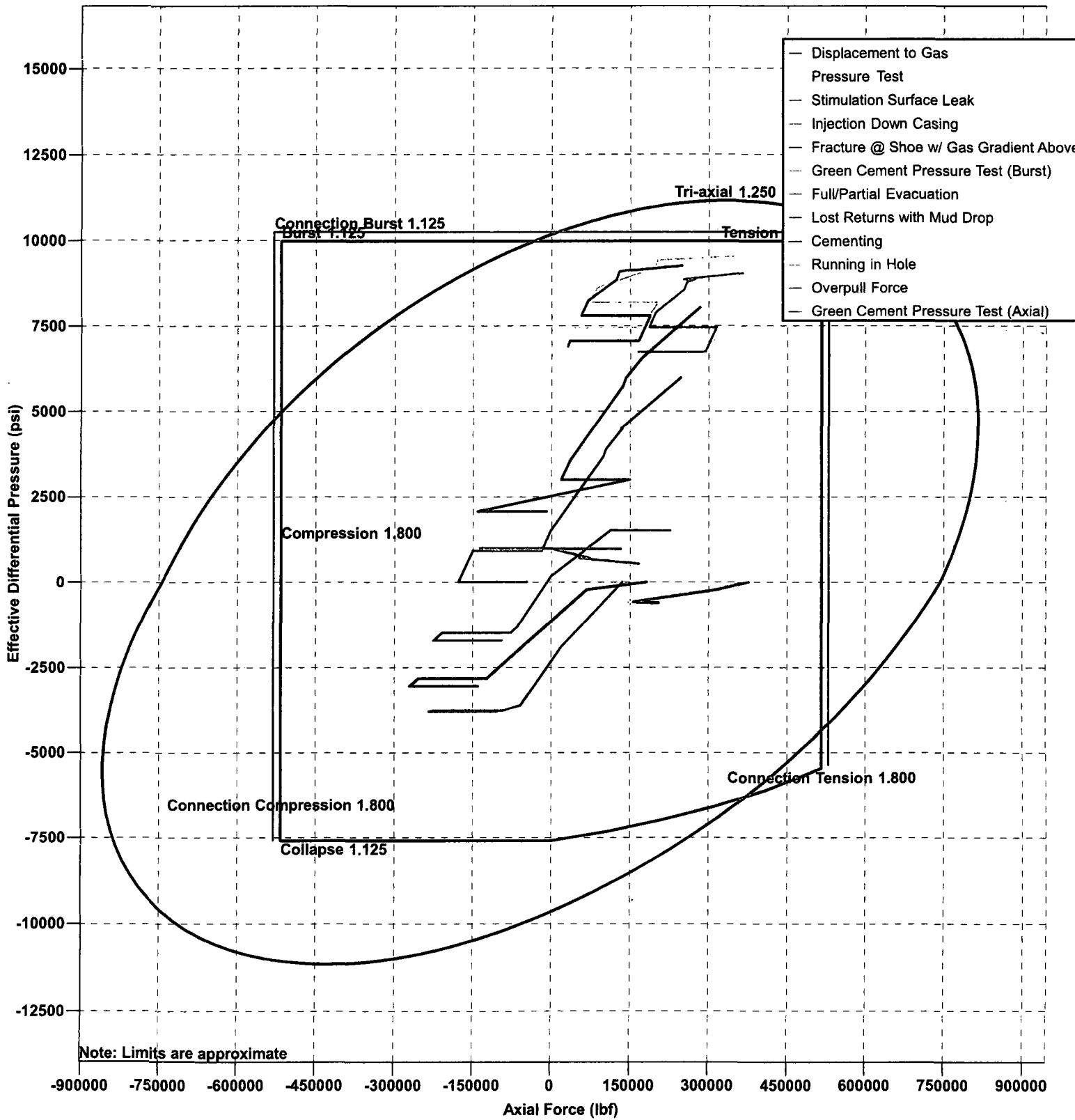

MARATHON OIL - H2S Preparedness and Contingency Plan Summary

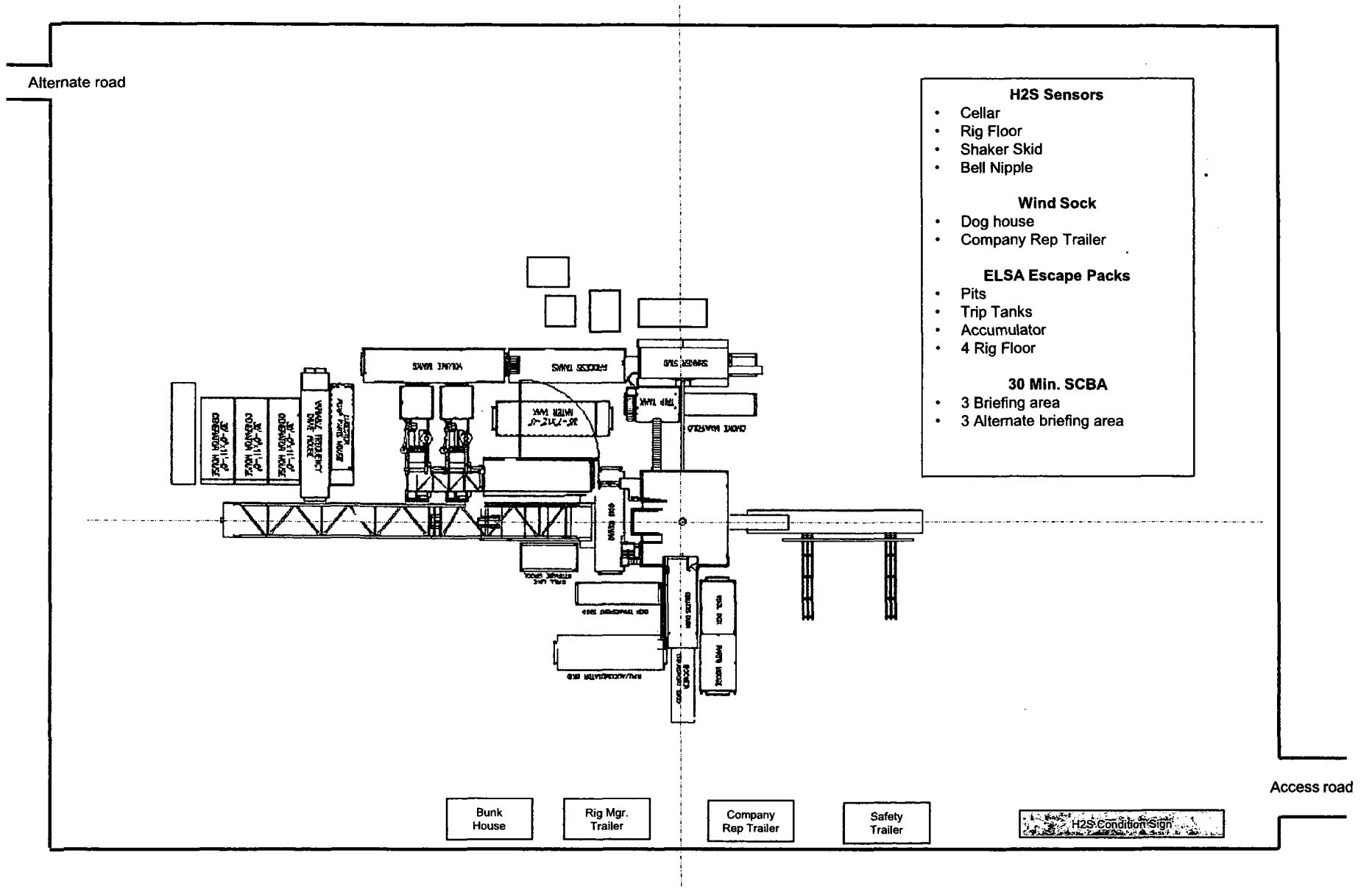



APD ID: 10400026517

Submission Date: 01/24/2018

Operator Name: MARATHON OIL PERMIAN LLC

Well Name: MADERA 19 FEDERAL 26 35 19 WXY

Well Number: 6H

Well Type: CONVENTIONAL GAS WELL

Well Work Type: Drill



[Show Final Text](#)

Section 1 - Existing Roads

Will existing roads be used? YES

Existing Road Map:

Existing_road_and_vicinity_map_20180123130235.pdf

Existing Road Purpose: ACCESS

Row(s) Exist? NO

ROW ID(s)

ID:

Do the existing roads need to be improved? NO

Existing Road Improvement Description:

Existing Road Improvement Attachment:

Section 2 - New or Reconstructed Access Roads

Will new roads be needed? NO

Section 3 - Location of Existing Wells

Existing Wells Map? YES

Attach Well map:

Existing_wells_map_20180122123158.pdf

Operator Name: MARATHON OIL PERMIAN LLC

Well Name: MADERA 19 FEDERAL 26 35 19 WXY

Well Number: 6H

Existing Wells description:

Section 4 - Location of Existing and/or Proposed Production Facilities

Submit or defer a Proposed Production Facilities plan? SUBMIT

Production Facilities description: Proposed Central Tank Battery (CTB) is proposed on the south side of the proposed Madera 19 Federal Com 26 35 19 well pad to allow for maximum interim reclamation of the well pad. - There are 10 - 750 bbl steel tanks for oil storage and 15 - 750 bbl steel tanks for water storage planned for the CTB. - No open top tanks will be used. - Open vent exhaust stacks will be modified to prevent birds or bats from entering, discourage perching, roosting, and nesting. - All chemical and fuel secondary containments will be covered for birds, wildlife, and livestock protection. The fluids will be disposed of as needed to prevent possible overflow. - The proposed CTB will have a secondary containment 1.5 times the holding capacity of largest storage tank plus freeboard to account for precipitation. - All above ground structures not subject to safety requirements will be painted a flat non-reflective shale green for blending with the surrounding environment. - At this time, the proposed CTB will have oil and water truck hauled from the facility. Pipelines/Flowlines: All flowlines transporting production from wells to the facility will remain on the pad; therefore, no further disturbance or ROW will be required. Powerlines: No power-lines will be needed. The power to the equipment will be provided via a natural gas generator.

Production Facilities map:

Madera_Facility_Site_Plan__002__20180122123302.pdf

Section 5 - Location and Types of Water Supply

Water Source Table

Water source use type: DUST CONTROL,
INTERMEDIATE/PRODUCTION CASING, STIMULATION, SURFACE
CASING

Describe type:

Source latitude: 32.0308

Source datum: NAD83

Water source permit type: PRIVATE CONTRACT

Source land ownership: PRIVATE

Water source transport method: PIPELINE

Source transportation land ownership: PRIVATE

Water source volume (barrels): 147500

Source volume (gal): 6195000

Water source type: GW WELL

Source longitude: -103.4053

Source volume (acre-feet): 19.011732

Water source use type: DUST CONTROL,
INTERMEDIATE/PRODUCTION CASING, STIMULATION, SURFACE
CASING

Describe type:

Source latitude: 32.0236

Source datum: NAD83

Water source permit type: PRIVATE CONTRACT

Water source type: GW WELL

Source longitude: -103.4131

Operator Name: MARATHON OIL PERMIAN LLC

Well Name: MADERA 19 FEDERAL 26 35 19 WXY

Well Number: 6H

Source land ownership: FEDERAL

Water source transport method: PIPELINE

Source transportation land ownership: FEDERAL

Water source volume (barrels): 147500

Source volume (acre-feet): 19.011732

Source volume (gal): 6195000

Water source and transportation map:

lease_water_caliche_map_20180123071347.pdf

Water source comments: Private ground water wells will supply water to existing fresh water ponds located in different locations that will be utilized for drilling operations pending demand and availability. • 1st proposed (JAZZ pond in Section 34,T25S,R35E) will be utilized for fresh water. • A temporary 10" expanding pipe transfer line will run North from pond along lease rd. then turn west along proposed access road approx. 5.89 Miles. • 2nd proposed (Black Mountain in section19 T26S R35E) will be utilized for fresh water. • A temporary 10" expanding pipe transfer line will run east from pond along access rd. then turn North along proposed access road approx. 1.90 miles. • 3rd proposed pond(Arena Roja in Section 19,T26S-R35E) will be utilized for fresh water. • A temporary 10" expanding pipe transfer line will run east from pond along access rd. then north along proposed access road approx. 9.47 Miles. • Fresh water line will run parallel to existing disturbance and will stay within 10' of access road. Proposed water suppliers Madera Brad Beckem Rockhouse
New water well? NO

New Water Well Info

Well latitude:

Well Longitude:

Well datum:

Well target aquifer:

Est. depth to top of aquifer(ft):

Est thickness of aquifer:

Aquifer comments:

Aquifer documentation:

Well depth (ft):

Well casing type:

Well casing outside diameter (in.):

Well casing inside diameter (in.):

New water well casing?

Used casing source:

Drilling method:

Drill material:

Grout material:

Grout depth:

Casing length (ft.):

Casing top depth (ft.):

Well Production type:

Completion Method:

Water well additional information:

State appropriation permit:

Additional information attachment:

Operator Name: MARATHON OIL PERMIAN LLC

Well Name: MADERA 19 FEDERAL 26 35 19 WXY

Well Number: 6H

Section 6 - Construction Materials

Construction Materials description: Caliche will be used to construct well pad and roads. Material will be purchased from a private permitted pit. The proposed source of construction material will be located: - Source 1: Bert Madera's mineral pit located in section 19, T26S, R35E - Source 2: Federal mineral pit located in section 22, T26S, R35E Payment shall be made by construction contractor. Notification shall be given to BLM at (575) 234-5909 at least 3 working days prior to commencing construction of well pad or related infrastructure.

Construction Materials source location attachment:

lease_water_caliche_map_20180123071844.pdf

Section 7 - Methods for Handling Waste

Waste type: DRILLING

Waste content description: Drilling fluids and produced oil and water from the well during drilling operations.

Amount of waste: 1000 barrels

Waste disposal frequency : Daily

Safe containment description: Lined steel tanks

Safe containmant attachment:

Waste disposal type: HAUL TO COMMERCIAL FACILITY **Disposal location ownership:** COMMERCIAL FACILITY

Disposal type description:

Disposal location description: Waste will be stored safely and disposed of properly in an NMOCD approved disposal facility.

Waste type: GARBAGE

Waste content description: Garbage and trash (solid waste)

Amount of waste: 1200 pounds

Waste disposal frequency : Weekly

Safe containment description: All garbage will be stored in closed containers

Safe containmant attachment:

Waste disposal type: HAUL TO COMMERCIAL FACILITY **Disposal location ownership:** COMMERCIAL FACILITY

Disposal type description:

Disposal location description: All garbage will be collected by a third party and disposed of properly at a State approved disposal facility.

Waste type: SEWAGE

Waste content description: Human waste and grey water.

Amount of waste: 600 barrels

Waste disposal frequency : Weekly

Safe containment description: Portable toilets and sewage tanks.

Operator Name: MARATHON OIL PERMIAN LLC

Well Name: MADERA 19 FEDERAL 26 35 19 WXY

Well Number: 6H

Safe containmant attachment:

Waste disposal type: HAUL TO COMMERCIAL FACILITY **Disposal location ownership:** COMMERCIAL FACILITY

Disposal type description:

Disposal location description: All sewage waste will be managed by a third party and disposed of properly at a State approved disposal facility.

Waste type: COMPLETIONS/STIMULATION

Waste content description: Oil and water from drilling operations

Amount of waste: 1000 barrels

Waste disposal frequency : Daily

Safe containment description: Steel tanks

Safe containmant attachment:

Waste disposal type: HAUL TO COMMERCIAL FACILITY **Disposal location ownership:** COMMERCIAL FACILITY

Disposal type description:

Disposal location description: Waste will be stored safely and disposed of properly in an NMOCD approved disposal facility.

Reserve Pit

Reserve Pit being used? NO

Temporary disposal of produced water into reserve pit?

Reserve pit length (ft.) Reserve pit width (ft.)

Reserve pit depth (ft.) Reserve pit volume (cu. yd.)

Is at least 50% of the reserve pit in cut?

Reserve pit liner

Reserve pit liner specifications and installation description

Cuttings Area

Cuttings Area being used? NO

Are you storing cuttings on location? YES

Description of cuttings location The well will be drilled utilizing a closed loop system. Drill cutting will be properly disposed of into lined steel tanks and taken to an NMOCD approved disposal facility.

Cuttings area length (ft.) Cuttings area width (ft.)

Cuttings area depth (ft.) Cuttings area volume (cu. yd.)

Is at least 50% of the cuttings area in cut?

WCuttings area liner

Operator Name: MARATHON OIL PERMIAN LLC

Well Name: MADERA 19 FEDERAL 26 35 19 WXY

Well Number: 6H

Cuttings area liner specifications and installation description

Section 8 - Ancillary Facilities

Are you requesting any Ancillary Facilities?: NO

Ancillary Facilities attachment:

Comments:

Section 9 - Well Site Layout

Well Site Layout Diagram:

MADERA_19_FEDERAL_26_35_19_Well_Plat_IR_20180430123452.pdf

MADERA_19_FEDERAL_26_35_19_well_surface_plat_20180430123502.pdf

Comments: Exterior well pad dimensions are 540' by 425'. Note this pad will have 4 total wells, see Well Pad Surface Plat. Interior well pad dimensions from first point of entry (well head) are: From west-320', north-220', east-220', south-205'. Tank battery pad dimensions are 180' by 350' on south for tanks and 75' by 235' on the east for separation equipment. Total disturbance area needed for construction activities will be 5.25 acres. Topsoil will be places on the north side of the pad to accommodate interim reclamation activities. Cut and fill will be minimal

Section 10 - Plans for Surface Reclamation

Type of disturbance: New Surface Disturbance

Multiple Well Pad Name: MADERA 19 FEDERAL 26 35 19

Multiple Well Pad Number: 363-1

Recontouring attachment:

MADERA_19_FEDERAL_26_35_19_Well_Plat_IR_20180430123513.pdf

Drainage/Erosion control construction: During construction, BMP's will be used to control erosion, runoff and siltation of surrounding area.

Drainage/Erosion control reclamation: BMP will be used to control erosion, runoff and siltation of surrounding area. All areas reclaimed will be ripped across the slope to prevent water erosion.

Well pad proposed disturbance (acres): 5.25	Well pad interim reclamation (acres): 2.03	Well pad long term disturbance (acres): 3.22
Road proposed disturbance (acres): 0	Road interim reclamation (acres): 0	Road long term disturbance (acres): 0
Powerline proposed disturbance (acres): 0	Powerline interim reclamation (acres): 0	Powerline long term disturbance (acres): 0
Pipeline proposed disturbance (acres): 0	Pipeline interim reclamation (acres): 0	Pipeline long term disturbance (acres): 0
Other proposed disturbance (acres): 0	Other interim reclamation (acres): 0	Other long term disturbance (acres): 0
Total proposed disturbance: 5.25	Total interim reclamation: 2.03	Total long term disturbance: 3.22

Disturbance Comments: Well pad only

Reconstruction method: Reclamation Objectives - The objective of interim reclamation is to restore vegetative cover and a portion of the landform sufficient to maintain healthy, biologically active topsoil; control erosion; and minimize habitat and

Operator Name: MARATHON OIL PERMIAN LLC

Well Name: MADERA 19 FEDERAL 26 35 19 WXY

Well Number: 6H

forage loss, visual impact, and weed infestation, during the life of the well or facilities. • The BLM will be notified at least 3 days prior to commencement of any reclamation procedures. • If circumstances allow, interim reclamation and/or final reclamation actions will be completed no later than 6 months from when the final well on the location has been completed or plugged. We will gain written permission from the BLM if more time is needed. • Reclamation will be performed by using the following procedures: For Interim Reclamation: • Within 6 months of first production, the well location and surrounding areas will be cleared of, and maintained free of, all materials, trash, and equipment not required for production. A plan will be submitted showing where interim reclamation will be completed in order to allow for safe operations, protection of the environment outside of drilled well, and following best management practices found in the BLM "Gold Book". • Current plans for interim reclamation include reducing the pad size to approximately 3.22 acres from the proposed size of 5.25 acres. • In areas planned for interim reclamation, all the surfacing material will be removed and returned to the original mineral pit or recycled to repair or build roads and well pads. • The areas planned for interim reclamation will then be recontoured to the original contour if feasible, or if not feasible, to an interim contour that blends with the surrounding topography as much as possible. Where applicable, the fill material of the well pad will be backfilled into the cut to bring the area back to the original contour. The interim cut and fill slopes prior to re-seeding will not be steeper than a 3:1 ratio, unless the adjacent native topography is steeper. Note: Constructed slopes may be much steeper during drilling, but will be recontoured to the above ratios during interim reclamation. • Topsoil will be evenly respread and aggressively revegetated over the entire disturbed area not needed for all-weather operations including cuts & fills. To seed the area, the proper BLM LPC seed mixture free of noxious weeds, will be used. • Proper erosion control methods will be used on the area to control erosion, runoff and siltation of the surrounding area. • The interim reclamation will be monitored periodically to ensure that vegetation has reestablished. For Final Reclamation: • Prior to final reclamation procedures, the well pad, road, and surrounding area will be cleared of material, trash, and equipment. • All surfacing material will be removed and returned to the original mineral pit or recycled to repair or build roads and well pads. • All disturbed areas, including roads, pipelines, pads, production facilities, and interim reclaimed areas will be recontoured to the contour existing prior to initial construction or a contour that blends in distinguishably with the surrounding landscape. Topsoil that was spread over the interim reclamation areas will be stockpiled prior to recontouring. The topsoil will be redistributed evenly over the entire disturbed site to ensure successful revegetation. • After all the disturbed areas have been properly prepared; the areas will be seeded with the proper BLM LPC seed mixture free of noxious weeds. • Proper erosion control methods will be used on the entire area to control erosion, runoff and siltation of the surrounding area.

Topsoil redistribution: The topsoil will be evenly distributed across all reclaimed areas, ripped across the slopes, and seed accordingly. During final reclamation, Marathon will grab and evenly redistribute topsoil across the entire disturbed area (disc plowing if needed) area and seed accordingly.

Soil treatment: Stockpile and seeded until used for interim or final reclamation. Topsoil and subsoil will be piled separately.

Existing Vegetation at the well pad: Mesquite, shinnery oak, sand dropseed, and sage.

Existing Vegetation at the well pad attachment:

Existing Vegetation Community at the road: NA

Existing Vegetation Community at the road attachment:

Existing Vegetation Community at the pipeline: NA

Existing Vegetation Community at the pipeline attachment:

Existing Vegetation Community at other disturbances: NA

Existing Vegetation Community at other disturbances attachment:

Non native seed used? NO

Non native seed description:

Seedling transplant description:

Operator Name: MARATHON OIL PERMIAN LLC

Well Name: MADERA 19 FEDERAL 26 35 19 WXY

Well Number: 6H

Will seedlings be transplanted for this project? NO

Seedling transplant description attachment:

Will seed be harvested for use in site reclamation? NO

Seed harvest description:

Seed harvest description attachment:

Seed Management

Seed Table

Seed type: OTHER

Seed source: COMMERCIAL

Seed name: BLM Sand LPC

Source name:

Source address:

Source phone:

Seed cultivar: Broadcast

Seed use location: WELL PAD

PLS pounds per acre: 38

Proposed seeding season: AUTUMN

Seed Summary

Total pounds/Acre: 38

Seed Type	Pounds/Acre
OTHER	38

Seed reclamation attachment:

Seed_Mixture_LPC_HEA_20180123085729.pdf

Operator Contact/Responsible Official Contact Info

First Name:

Last Name:

Phone:

Email:

Seedbed prep: Rip native topsoil stockpiled during construction activities across the slope

Seed BMP:

Seed method: Broadcast seed with spreader

Existing invasive species? NO

Existing invasive species treatment description:

Existing invasive species treatment attachment:

Operator Name: MARATHON OIL PERMIAN LLC

Well Name: MADERA 19 FEDERAL 26 35 19 WXY

Well Number: 6H

Weed treatment plan description: Marathon will control weeds per Federal, County and State regulations by contracting a certified third party.

Weed treatment plan attachment:

Monitoring plan description: Marathon will monitor all disturbed areas and lease roads leading to well pad monthly for weeds through routine inspections.

Monitoring plan attachment:

Success standards: Maintain all disturbed areas as per Gold Book Standards.

Pit closure description: N/A

Pit closure attachment:

Section 11 - Surface Ownership

Disturbance type: WELL PAD

Describe:

Surface Owner: BUREAU OF LAND MANAGEMENT

Other surface owner description:

BIA Local Office:

BOR Local Office:

COE Local Office:

DOD Local Office:

NPS Local Office:

State Local Office:

Military Local Office:

USFWS Local Office:

Other Local Office:

USFS Region:

USFS Forest/Grassland:

USFS Ranger District:

Disturbance type: EXISTING ACCESS ROAD

Describe:

Surface Owner: BUREAU OF LAND MANAGEMENT

Other surface owner description:

BIA Local Office:

Operator Name: MARATHON OIL PERMIAN LLC

Well Name: MADERA 19 FEDERAL 26 35 19 WXY

Well Number: 6H

BOR Local Office:

COE Local Office:

DOD Local Office:

NPS Local Office:

State Local Office:

Military Local Office:

USFWS Local Office:

Other Local Office:

USFS Region:

USFS Forest/Grassland:

USFS Ranger District:

Section 12 - Other Information

Right of Way needed? NO

Use APD as ROW?

ROW Type(s):

ROW Applications

SUPO Additional Information:

Use a previously conducted onsite? YES

Previous Onsite information: Performed 11/28/2017. Marathon Oil Attendees: Brian Hall and Nancy Pohl BLM Attendee: Colleen Cepero-Rios

Other SUPO Attachment

Madera_Onsite_20180123091758.pdf

General_Lease_Information_20180123131232.pdf

Madera_19_Federal_26_35_19_TB_1H_Gas_Capture_Plan_NMOCD_20180118_20180430123558.pdf

Section 3 - Unlined Pits

Would you like to utilize Unlined Pit PWD options? NO

Produced Water Disposal (PWD) Location:

PWD surface owner:

PWD disturbance (acres):

Unlined pit PWD on or off channel:

Unlined pit PWD discharge volume (bbl/day):

Unlined pit specifications:

Precipitated solids disposal:

Describe precipitated solids disposal:

Precipitated solids disposal permit:

Unlined pit precipitated solids disposal schedule:

Unlined pit precipitated solids disposal schedule attachment:

Unlined pit reclamation description:

Unlined pit reclamation attachment:

Unlined pit Monitor description:

Unlined pit Monitor attachment:

Do you propose to put the produced water to beneficial use?

Beneficial use user confirmation:

Estimated depth of the shallowest aquifer (feet):

Does the produced water have an annual average Total Dissolved Solids (TDS) concentration equal to or less than that of the existing water to be protected?

TDS lab results:

Geologic and hydrologic evidence:

State authorization:

Unlined Produced Water Pit Estimated percolation:

Unlined pit: do you have a reclamation bond for the pit?

Is the reclamation bond a rider under the BLM bond?

Unlined pit bond number:

Unlined pit bond amount:

Additional bond information attachment:

Section 4 - Injection

Would you like to utilize Injection PWD options? NO

Produced Water Disposal (PWD) Location:

PWD surface owner:

PWD disturbance (acres):

Injection PWD discharge volume (bbl/day):

Injection well mineral owner:

Injection well type:

Injection well number:

Assigned injection well API number?

Injection well new surface disturbance (acres):

Minerals protection information:

Mineral protection attachment:

Underground Injection Control (UIC) Permit?

UIC Permit attachment:

Injection well name:

Injection well API number:

Section 5 - Surface Discharge

Would you like to utilize Surface Discharge PWD options? NO

Produced Water Disposal (PWD) Location:

PWD surface owner:

PWD disturbance (acres):

Surface discharge PWD discharge volume (bbl/day):

Surface Discharge NPDES Permit?

Surface Discharge NPDES Permit attachment:

Surface Discharge site facilities information:

Surface discharge site facilities map:

Section 6 - Other

Would you like to utilize Other PWD options? NO

Produced Water Disposal (PWD) Location:

PWD surface owner:

PWD disturbance (acres):

Other PWD discharge volume (bbl/day):

Other PWD type description:

Other PWD type attachment:

Have other regulatory requirements been met?

Other regulatory requirements attachment:



U.S. Department of the Interior
BUREAU OF LAND MANAGEMENT

Bond Info Data Report

06/12/2018

Bond Information

Federal/Indian APD: FED

BLM Bond number: WYB002107

BIA Bond number:

Do you have a reclamation bond? NO

Is the reclamation bond a rider under the BLM bond?

Is the reclamation bond BLM or Forest Service?

BLM reclamation bond number:

Forest Service reclamation bond number:

Forest Service reclamation bond attachment:

Reclamation bond number:

Reclamation bond amount:

Reclamation bond rider amount:

Additional reclamation bond information attachment:

Operator Name: MARATHON OIL PERMIAN LLC

Well Name: MADERA 19 FEDERAL 26 35 19 WXY

Well Number: 6H

	NS-Foot	NS Indicator	EW-Foot	EW Indicator	Twsp	Range	Section	Aliquot/Lot/Tract	Latitude	Longitude	County	State	Meridian	Lease Type	Lease Number	Elevation	MD	TVD
PPP Leg #1	0	FNL	132 0	FWL	26S	35E	18	Aliquot NWN W	32.03595 19	- 103.4104 019	LEA	NEW MEXI CO	NEW MEXI CO	F	NMNM 093223	- 941 6	176 38	126 82
EXIT Leg #1	231 2	FSL	132 0	FWL	26S	35E	18	Aliquot NWS W	32.04230 72	- 103.4104 023	LEA	NEW MEXI CO	NEW MEXI CO	F	NMNM 093223	- 941 6	199 50	126 82
BHL Leg #1	231 2	FSL	132 0	FWL	26S	35E	18	Aliquot NWS W	32.04230 72	- 103.4104 023	LEA	NEW MEXI CO	NEW MEXI CO	F	NMNM 093223	- 941 6	199 50	126 82



Section 1 - General

Would you like to address long-term produced water disposal? NO

Section 2 - Lined Pits

Would you like to utilize Lined Pit PWD options? NO

Produced Water Disposal (PWD) Location:

PWD surface owner:

PWD disturbance (acres):

Lined pit PWD on or off channel:

Lined pit PWD discharge volume (bbl/day):

Lined pit specifications:

Pit liner description:

Pit liner manufacturers information:

Precipitated solids disposal:

Describe precipitated solids disposal:

Precipitated solids disposal permit:

Lined pit precipitated solids disposal schedule:

Lined pit precipitated solids disposal schedule attachment:

Lined pit reclamation description:

Lined pit reclamation attachment:

Leak detection system description:

Leak detection system attachment:

Lined pit Monitor description:

Lined pit Monitor attachment:

Lined pit: do you have a reclamation bond for the pit?

Is the reclamation bond a rider under the BLM bond?

Lined pit bond number:

Lined pit bond amount:

Additional bond information attachment: