

CHEVRON DRILLING REFERENCE SERIES VOLUME ELEVEN WELL CONTROL AND BLOWOUT PREVENTION

C. CLASS II CHOKE MANIFOLD

The Class II choke manifold is suitable for all Class II workovers and drilling operations. The Class II choke manifold is shown below in Figure 11J.7. Specific design features of the Class II choke manifold include:

1. The manifold is attached to the tubing/casing head when a Class II-A preventer stack is used. This hook-up is only recommended for Class II workover operations.
2. The manifold is attached to a drilling spool or top ram preventer side outlets when a Class II-B preventer stack is in use.
3. The minimum internal diameter is 2" (nominal) for outlets, flanges, valves and lines.
4. Includes two steel gate valves in the choke line at the wellhead/drilling spool outlet. The inside choke line valve may be remotely controlled (HCR).
5. Includes one manually adjustable choke which is installed on the side of the manifold cross. Steel isolation gate valves are installed between the choke and the cross, and downstream of the choke.
6. Includes one bleed line installed on the side of the manifold cross which is isolated by a steel gate valve.
7. Includes a pressure gauge suitable for drilling service which can display the casing pressure within view of the choke operator.
8. Screwed connections may be used in lieu of flanges or clamps.

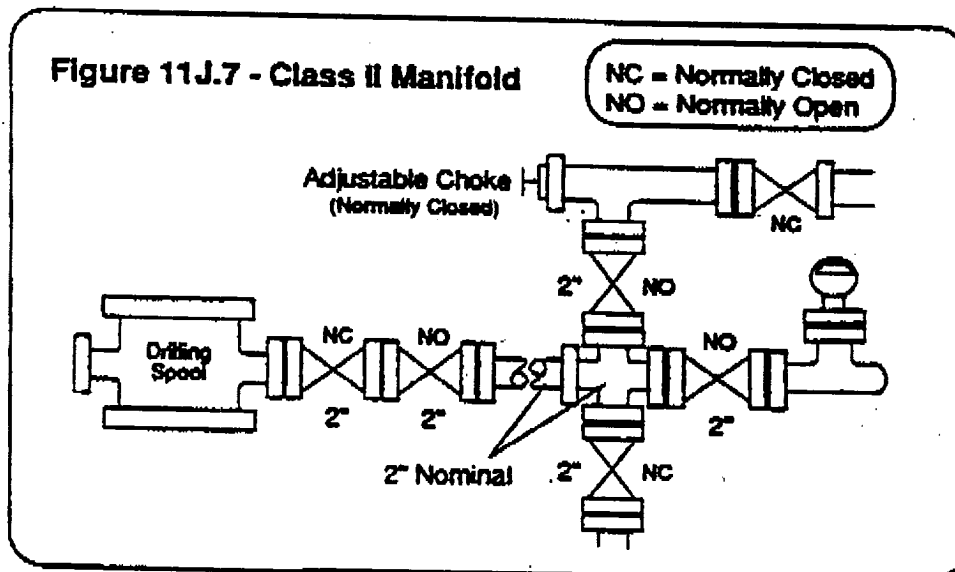

IF THE DATE DOES NOT
INDICATE WHEN
NO IDENTICAL LOGS
WILL BE RELEASED

**CHEVRON DRILLING REFERENCE SERIES
VOLUME ELEVEN
WELL CONTROL AND BLOWOUT PREVENTION**

D. CLASS II-B BLOWOUT PREVENTER STACK:

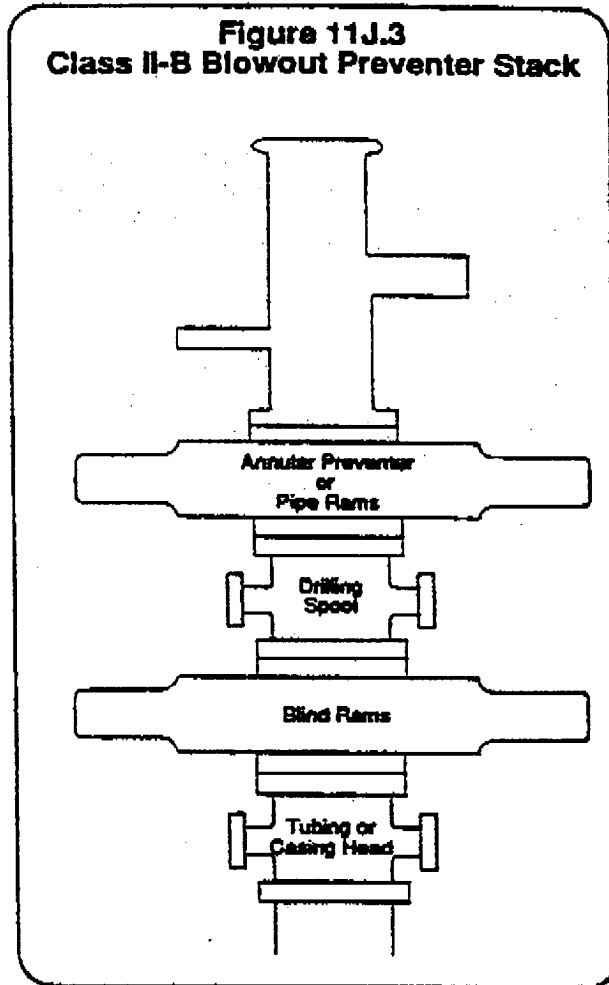

The Class II-B preventer stack is designed for drilling or workover operations. It is composed of a single hydraulically operated annular preventer on top, then a drilling spool, and a single blind ram preventer on bottom. In an alternate configuration, a single pipe ram preventer may be substituted for the annular preventer. The choke and kill lines are installed onto the drilling spool and must have a minimum internal diameter of 2". An emergency kill line may be installed on the wellhead. As the maximum anticipated surface pressure of this stack is less than 2000 psi, screwed connections may be used. All components must be of steel construction. The Class II-B blowout preventer stack is shown to the left in Figure 11J.3.

DATE DOES NOT
INDICATE WHEN
CONFIDENTIAL LOGS
WILL BE RELEASED