

INJECTION WELL DATA SHEET

OPERATOR: Texaco Exploration & Production Inc. WELL: Rhodes Yates Unit #10 WIW
 FOOTAGE LOCATION: 2310 FSL, 660 FWL Sec./Twn/Rng: Unit L, Section 27, T-26-S, R-37-E
 Additional pay will be added to Middle Yates. DF = 2996' Lea County, New Mexico

SCHEMATIC

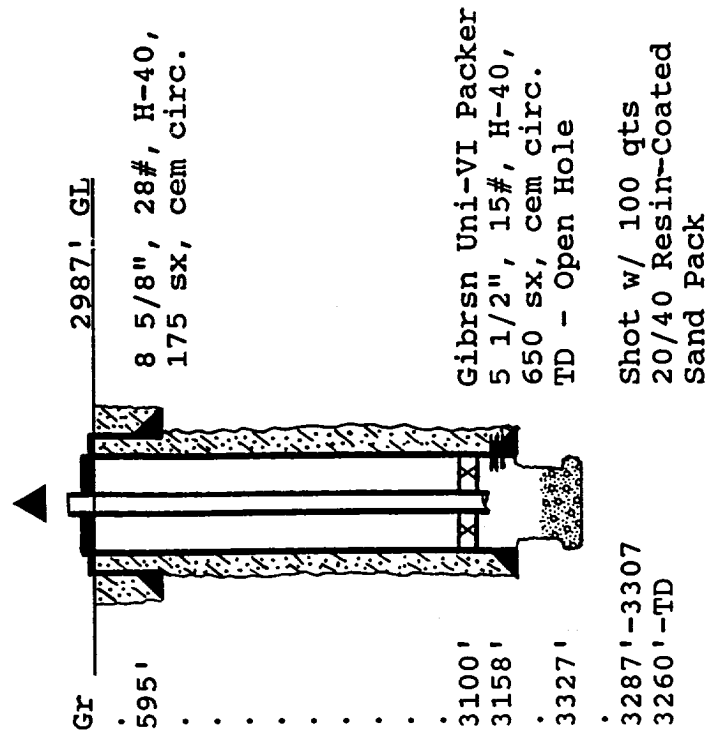

TABULAR DATA

Surface Casing: Set at: 595 '
 Size 8 5/8, 28# Cemented with 175 sx.
 TOC surface , determined by circulated
 Hole Size NR Comp. Date 4-26-43
Intermediate casing: Set at: '
 Size none Cemented with sx.
 TOC , determined by
 Hole Size
Production Casing: Set at: 3158 '
 Size 5 1/2", 15# Cemented with 650 sx.
 TOC surface , determined by circulated
 Hole Size 7 7/8 '

Injection Interval:

3122 ' to 3327 ' through: Open Hole

Tubing: 2 3/8", 4.7#, J-55, ICC, 2000# WP

Estimated Tops:
 Salt 1400' - 2870'
 Yates 3008'
 Oil Pay 3287'

** Additional perfs from 3122'-3153'