

# **C-147 REGISTRATION PACKAGE**

## **North Alamito Unit A19/N17 AST Pad** **Recycling Containment and Recycling Facility**

February 2026



## **ENDURING RESOURCES IV, LLC**

---

**DJR Operating, LLC A Subsidiary Company of Enduring Resource, LLC**

**200 Energy Court  
Farmington, New Mexico 87401  
Phone: (505) 636-9720**

District I  
1625 N. French Dr., Hobbs, NM 88240  
District II  
811 S. First St., Artesia, NM 88210  
District III  
1000 Rio Brazos Road, Aztec, NM 87410  
District IV  
1220 S. St. Francis Dr., Santa Fe, NM 87505

State of New Mexico  
Energy Minerals and Natural Resources  
Department  
Oil Conservation Division  
1220 South St. Francis Dr.  
Santa Fe, NM 87505

Form C-147  
Revised April 3, 2017

## Recycling Facility and/or Recycling Containment

Type of Facility:  Recycling Facility  Recycling Containment\*  
Type of action:  Permit  Registration  
 Modification  Extension  
 Closure  Other (explain) \_\_\_\_\_

\* At the time C-147 is submitted to the division for a Recycling Containment, a copy shall be provided to the surface owner.

Be advised that approval of this request does not relieve the operator of liability should operations result in pollution of surface water, ground water or the environment. Nor does approval relieve the operator of its responsibility to comply with any other applicable governmental authority's rules, regulations or ordinances.

1.  
Operator: DJR Operating, LLC (For multiple operators attach page with information) OGRID #: 371838  
Address: 200 Energy Court, Farmington, New Mexico 87401  
Facility or well name (include API# if associated with a well): North Alamito Unit A19/N17 AST Pad  
OCD Permit Number: \_\_\_\_\_ (For new facilities the permit number will be assigned by the district office)  
U/L or Qtr/Qtr SW/NW Section 20 Township 23N Range 07W County: Sandoval  
Surface Owner:  Federal  State  Private  Tribal Trust or Indian Allotment

2.  
 **Recycling Facility:**  
Location of recycling facility (if applicable): Latitude 36.2151087 Longitude -107.603620 NAD83  
Proposed Use:  Drilling\*  Completion\*  Production\*  Plugging \*  
*\*The re-use of produced water may NOT be used until fresh water zones are cased and cemented*  
 Other, *requires permit for other uses. Describe use, process, testing, volume of produced water and ensure there will be no adverse impact on groundwater or surface water.*  
 Fluid Storage  
 Above ground tanks  Recycling containment  Activity permitted under 19.15.17 NMAC explain type \_\_\_\_\_  
 Activity permitted under 19.15.36 NMAC explain type: \_\_\_\_\_  Other explain \_\_\_\_\_  
 For multiple or additional recycling containments, attach design and location information of each containment  
 **Closure Report (required within 60 days of closure completion):**  Recycling Facility Closure Completion Date: \_\_\_\_\_

3.  
 **Recycling Containment:**  
 Annual Extension after initial 5 years (attach summary of monthly leak detection inspections for previous year)  
Center of Recycling Containment (if applicable): Latitude 36.2151087 Longitude -107.603620 NAD83  
 For multiple or additional recycling containments, attach design and location information of each containment  
 Lined  Liner type: Thickness 40 mil  LLDPE  HDPE  PVC  Other \_\_\_\_\_  
 String-Reinforced  
Liner Seams:  Welded  Factory  Other \_\_\_\_\_ Volume: 43,000 bbl Dimensions: **Diameter 163'** x Height **12'**  
 Recycling Containment Closure Completion Date: \_\_\_\_\_

4.

**Bonding:**

Covered under bonding pursuant to 19.15.8 NMAC per 19.15.34.15(A)(2) NMAC (These containments are limited to only the wells owned or operated by the owners of the containment.)

Bonding in accordance with 19.15.34.15(A)(1). Amount of bond \$ \_\_\_\_\_ (work on these facilities cannot commence until bonding amounts are approved)

Attach closure cost estimate and documentation on how the closure cost was calculated.

5.

**Fencing:**

Four foot height, four strands of barbed wire evenly spaced between one and four feet

Alternate. Please specify \_\_\_\_\_ **See variance request in registration package Exhibit H**

6.

**Signs:**

12"x 24", 2" lettering, providing Operator's name, site location, and emergency telephone numbers

Signed in compliance with 19.15.16.8 NMAC

7.

**Variiances:**

Justifications and/or demonstrations that the proposed variance will afford reasonable protection against contamination of fresh water, human health, and the environment.

**Check the below box only if a variance is requested:**

Variance(s): Requests must be submitted to the appropriate division district for consideration of approval. If a Variance is requested, include the variance information on a separate page and attach it to the C-147 as part of the application.

**If a Variance is requested, it must be approved prior to implementation.**

8.

**Siting Criteria for Recycling Containment**

*Instructions: The applicant must provide attachments that demonstrate compliance for each siting criteria below as part of the application. Potential examples of the siting attachment source material are provided below under each criteria.*

<b>General siting</b>	
Ground water is less than 50 feet below the bottom of the Recycling Containment. NM Office of the State Engineer - iWATERS database search; USGS; Data obtained from nearby wells	<input type="checkbox"/> Yes <input checked="" type="checkbox"/> No <input type="checkbox"/> NA
Within incorporated municipal boundaries or within a defined municipal fresh water well field covered under a municipal ordinance adopted pursuant to NMSA 1978, Section 3-27-3, as amended. - Written confirmation or verification from the municipality; written approval obtained from the municipality	<input type="checkbox"/> Yes <input checked="" type="checkbox"/> No <input type="checkbox"/> NA
Within the area overlying a subsurface mine. - Written confirmation or verification or map from the NM EMNRD-Mining and Minerals Division	<input type="checkbox"/> Yes <input checked="" type="checkbox"/> No
Within an unstable area. - Engineering measures incorporated into the design; NM Bureau of Geology & Mineral Resources; USGS; NM Geological Society; topographic map	<input type="checkbox"/> Yes <input checked="" type="checkbox"/> No
Within a 100-year floodplain. FEMA map	<input type="checkbox"/> Yes <input checked="" type="checkbox"/> No
Within 300 feet of a continuously flowing watercourse, or 200 feet of any other significant watercourse, or lakebed, sinkhole, or playa lake (measured from the ordinary high-water mark). - Topographic map; visual inspection (certification) of the proposed site	<input type="checkbox"/> Yes <input checked="" type="checkbox"/> No
Within 1000 feet from a permanent residence, school, hospital, institution, or church in existence at the time of initial application. - Visual inspection (certification) of the proposed site; aerial photo; satellite image	<input type="checkbox"/> Yes <input checked="" type="checkbox"/> No
Within 500 horizontal feet of a spring or a fresh water well used for domestic or stock watering purposes, in existence at the time of initial application. - NM Office of the State Engineer - iWATERS database search; visual inspection (certification) of the proposed site	<input type="checkbox"/> Yes <input checked="" type="checkbox"/> No
Within 500 feet of a wetland. - US Fish and Wildlife Wetland Identification map; topographic map; visual inspection (certification) of the proposed site	<input type="checkbox"/> Yes <input checked="" type="checkbox"/> No

9.

**Recycling Facility and/or Containment Checklist:**

*Instructions: Each of the following items must be attached to the application. Indicate, by a check mark in the box, that the documents are attached.*

- Design Plan - based upon the appropriate requirements. – **Section 3 of the C-147 Registration Package**
- Operating and Maintenance Plan - based upon the appropriate requirements. - **Section 4 of the C-147 Registration Package**
- Closure Plan - based upon the appropriate requirements. - **Section 5 of the C-147 Registration Package**
- Site Specific Groundwater Data – **Exhibit D of the C-147 Registration Package**
- Siting Criteria Compliance Demonstrations – **Section 2 of the C-147 Registration Package**
- Certify that notice of the C-147 (only) has been sent to the surface owner(s) – **C-147 package is being submitted concurrently to the Division and BLM FFO. See Exhibit C of the C-147 Registration Package for additional surface owner notification.**

10.

**Operator Application Certification:**

I hereby certify that the information and attachments submitted with this application are true, accurate and complete to the best of my knowledge and belief.

Name (Print): Heather Huntington Title: Regulatory Specialist

Signature: Heather Huntington Date: 03/03/2026

e-mail address: hhuntington@enduringresources.com Telephone: 505-636-9751

11.

OCD Representative Signature: Victoria Venegas Approval Date: 03/20/2026

Title: Senior Environmental Scientist OCD Permit Number: FVV2607936716

- OCD Conditions \_\_\_\_\_
- Additional OCD Conditions on Attachment \_\_\_\_\_

# TABLE OF CONTENTS

---

1.	INTRODUCTION .....	1
2.	SITING CRITERIA.....	2
3.	DESIGN AND CONSTRUCTION SPECIFICATIONS .....	4
4.	MAINTENANCE AND OPERATING PLAN.....	5
5.	CLOSURE PLAN.....	6
	EXHIBIT A. PLAT .....	A
	EXHIBIT B. RECYCLING FACILITY AND RECYCLING CONTAINMENT SITE DIAGRAM.....	B
	EXHIBIT C. SURFACE OWNER NOTIFICATION .....	C
	EXHIBIT D. GROUND WATER REPORT .....	D
	EXHIBIT E. SITING CRITERIA MAPS .....	E
	EXHIBIT F. AQUATIC RESOURCES DELINEATION TECHNICAL MEMORANDUM.....	F
	EXHIBIT G. MANUFACTURER’S SPECIFICATIONS .....	G
	EXHIBIT H. VARIANCE REQUESTS .....	H

## 1. INTRODUCTION

Applicant	DJR Operating, LLC Enduring Resources, LLC & DJR Operating, LLC are wholly owned subsidiaries of Enduring Resources IV, LLC. Leases, rights of ways, wells, and other property interests will continue to be held in their current entity names.
OGRID	371838
Project Name	North Alamito Unit A19/N17 AST Pad Recycling Containment and Recycling Facility
Project Type	Recycling Facility & Recycling Containment
Legal Location	Southwest ¼ of the northwest ¼ of Section 20, Township 23N, Range 07W, Sandoval County
Surface Owner	Private Owner (Jason W. Gallegos)

In accordance with 19.15.34 NMAC, DJR Operating, LLC (DJR), a subsidiary company of Enduring Resources IV, LLC requests registration of their North Alamito Unit A19/N17 AST Pad Recycling Containment and Recycling Facility through the approval of this C-147 registration and permit package.

The recycling containment will consist of one 43,000 barrel (bbl) aboveground storage tank (AST). Per 19.15.34.7 B. NMAC a **“Recycling containment”** is a storage containment which incorporates a synthetic liner as the primary and secondary containment device and is used solely in conjunction with a recycling facility for the storage, treatment or recycling of produced water only for the purpose of drilling, completion, production or plugging of wells used in connection with the development of oil or gas or both. This AST containment falls within this definition and must meet all applicable requirements of a Recycling Containment in Rule 19.15.34 NMAC.

The recycling facility will consist of up to thirty 400 bbl vertical frac tanks with a consolidated volume of 12,000 bbls to treat (mechanical and chemical reconditioning process) produced water for reuse. DJR will only set as many tanks anticipated to be needed based on incoming volumes and extent of treatment necessary. As defined in 19.15.34.7 A. NMAC a **“Recycling facility”** is a stationary or portable facility used exclusively for the treatment, re-use or recycling of produced water. A recycling facility does not include oilfield equipment such as separators, heater treaters and scrubbers in which produced water may be used. These tanks will be used as upright gun barrel oil water separators. This oil separation process will prevent having any visible layer of oil on the surface of the recycling containment in accordance with Rule 19.15.34.13 B.(1).

Per 19.15.34.9 A. water (produced water and Entrada water) stored/processed through this temporary recycling facility and containment will be used as part of a permitted operation for drilling, completing, and producing DJR Operating, LLC and Enduring Resources, LLC wells.

See Exhibit A for the site survey plat and Exhibit B for a site diagram of the proposed AST and recycling facility layout. This facility will not be used for the disposal of produced water.

The North Alamito Unit A19/N17 AST Pad is located at 36.215087° N, -107.603620° W, within Section 20, Township 23N, Range 07W, in Sandoval County, New Mexico. The site is located on private lands. DJR has entered into a Surface Use and Compensation Agreement with Jason W. Gallegos to use a tract of land in the SW ¼ of the NW ¼ of Section 20, Township 23N, Range 07W for the North Alamito Unit A19/N17 AST Pad. See Exhibit C, Recordation Notice and Memorandum of Surface Use and Compensation Agreement. Additionally, per New Mexico Oil Conservation Division (NMOCD) Form C-147, DJR will provide a copy of this registration package to Jason W. Gallegos concurrently with the submittal to the division.

## C-147 Registration Package

This document provides supplemental information to NMOCD Form C-147 that is required for registration, including siting criteria and demonstrations, design and construction plan, operating and maintenance plan, closure plan, closure, and site reclamation requirements, and surface owner notification.

Upon approval of this registration, the recycling containment located at this facility will be operated for up to 5 years.

If the AST containment is found to be needed beyond 5 years, DJR will submit annual extensions to NMOCD on Form C-147 at least 30 days prior to expiration. The extension request will include a summary of all monthly inspections of the containment, including monitoring of the leak detection system indicating that the containment's integrity has not been compromised.

## 2. SITING CRITERIA

### 2.1. Depth to Groundwater 19.15.34.11 A.(1)

Per 19.15.34.11 B. NMAC, DJR requests use of POD SJ-04054 in the southwest ¼ of the northwest ¼ of Section 14, Township 23N, Range 07W as evidence of depth to ground water in this area. SJ-04054 is located approximately 3 miles northeast and has a measured depth to groundwater at 180 feet. With the proposed containment being an above ground tank, water depth estimated to be greater than 180 feet, and elevation similar to the SJ-04054 water well, the groundwater depth is expected to be greater than 50 feet below the bottom of the recycling containment. See Exhibit D for the water well summary. Additional average depth to ground water information can be found below.

Average, Minimum, and Maximum depth to ground water within T23N R07W = 900', 900', 900'

Average, Minimum, and Maximum depth to ground water within T23N R08W = 290', 290', 290'

Average, Minimum, and Maximum depth to ground water within T22N R08W = 1106', 1106', 1106'

Average, Minimum, and Maximum depth to ground water within T23N R06W = 200', 200', 200'

### 2.2. Distance to Surface Water 19.15.34.11 A.(2)

There are no continuously flowing watercourses within 300 feet; nor, any other significant watercourse or lakebeds, sinkholes, or playa lakes within 200 feet of the proposed AST.

DJR contracted Barr Engineering Co. (Barr) in January of 2026 to assess all surrounding drainages per 19.15.34.11 A.(2) NMAC. In the report provided to DJR, Barr summarized the following. This report is attached hereto as Exhibit F:

*One drainage with an OHWM was observed within 200 feet of the North Alamito Unit A19/N17 AST Pad. Based on the SDAM performed by John Dodge and verified using the SDAM online tool, this drainage would be considered ephemeral and not a jurisdictional WOTUS. Two points were sampled as shown on Map 2 and in Photographs 1 and 2.*

*Based on the regulatory framework (Section 1), evaluation of the survey area, and the USACE Albuquerque District's current policies regarding jurisdictional determinations, it is Barr's professional opinion that under the current CWA rule, there are no features present in the survey area that would be considered jurisdictional WOTUS.*

*These conclusions are based on Barr's professional opinion. The USACE has the final regulatory authority to determine the presence and extent of jurisdictional WOTUS. The NMOCD has the final regulatory authority for determining the presence of continuously flowing watercourses, significant watercourses, or wetlands and their boundaries for the permitting and registration applicable to 19.15.34 NMAC.*

### 2.3. Distance to Structures 19.15.34.11 A.(3)

The recycling containment is not located within 1,000 feet of a permanent residence, school, hospital, institution, or church in existence at the time of this application. As shown on the aerial map in Exhibit E Map 2, there are no

## C-147 Registration Package

permanent residences, schools, hospitals, institutions, or churches within the 1000-foot buffer ring of the staging area. A field visit verified there no new structure has been erected since the aerial imagery was obtained.

**2.4. Distance to Non-Public Water Supply and Springs 19.15.34.11 A.(4)**

The recycling facility/containment is not located within 500 horizontal feet of a spring or fresh water well used for domestic or stock watering purposes in existence at the time of this application as shown on Exhibit E Maps 1 and 2. Map 1 shows wells and springs/seeps regardless of use type in the surrounding area and Map 2 shows that no water wells, springs, or seeps are located within the 500-foot buffer of the pad. The nearest freshwater well according to New Mexico Office of the State Engineer (NM-OSE) for domestic or stock water use is 3 miles northeast. The nearest spring/seep according to the National Hydrologic Dataset (NHD) is approximately 2.5 miles to the northeast.

**2.5. Distance to Municipal Boundaries and Defined Municipal Fresh Water Well Fields 19.15.34.11 A.(5)**

The recycling facility is not within any incorporated municipal boundaries nor within a defined municipal fresh water well field covered by a municipal ordinance adopted pursuant to Section 3-27-3 NMSA 1978, as amended. Exhibit E Map 1 shows the nearest municipal boundary being Cuba, New Mexico approximately 36.8 miles southeast.

**2.6. Distance to Wetland 19.15.34.11 A.(6)**

The recycling facility/containment is not located within 500 feet of a wetland per the evidence provided below and detailed in the Aquatic Resource Delineation Technical Memorandum attached hereto as Exhibit F.

According to the US Fish and Wildlife Service National Wetland Inventory (NWI) no wetlands are located within 500 feet of the AST Pad. Since the NWI is identified and mapped from a desktop perspective utilizing photo-signatures the resulting data is a desktop approximation of potential wetlands and non-wetland riparian habitat. Thus, field investigation is necessary to confirm or deny wetland status based on the presence of hydric soils or hydrophytes.

DJR contracted Barr Engineering Co. (Barr) in January of 2026 to assess all surrounding drainages per 19.15.34.11 A.(2) NMAC. In the report provided to DJR, Barr summarized the following. This report is attached hereto as Exhibit F:

*No wetlands are located within 500 feet of the North Alamito Unit A19/N17 AST Pad. No FEMA 100-year flood zones are in the survey area.*

*Based on the regulatory framework (Section 1), evaluation of the survey area, and the USACE Albuquerque District's current policies regarding jurisdictional determinations, it is Barr's professional opinion that under the current CWA rule, there are no features present in the survey area that would be considered jurisdictional WOTUS.*

**2.7. Distance to Subsurface Mines 19.15.34.11 A.(7)**

According to New Mexico Energy, Minerals and Natural Resources Department (EMNRD) Mining and Minerals Divisions database, there are no subsurface mines in Township 23N, Range 07W, Sandoval County, New Mexico. See Exhibit E Map 1 showing mines regardless of status near the project area. The nearest EMNRD recorded permit (permanent closure, reclaimed and released) is a humate mine approximately 16.7 miles south.

**2.8. Site Stability 19.15.34.11 A.(8)**

The recycling containment is not located in an unstable area. DJR's construction practices provide adequate compaction of the pad surface for the anticipated load of the recycling facility and AST containment.

The following additional best management practices will be implemented during pad construction to prevent equipment settling and ensure site stability.

- Prior to earthwork, all trees (if applicable) and slash/brush, will be mulched and incorporated into the topsoil. Tree roots and trucks will be removed from the site. The topsoil (vegetative root layer) and mulched organic matter will be stripped from location and windrowed along the perimeter of location. Topsoil will not be used for pad construction as the organic matter mixed within the soil prevents adequate compaction.
- Subsoil horizons will be utilized to construct a balanced (high areas are cut and used to fill low areas) location. Fill slopes will be deposited and compacted in approximate 6-inch lifts with optimal soil moisture content.
- No soil deemed too wet from inclement weather will be utilized for construction as adequate compaction cannot be achieved. Additionally, if construction occurs during winter months, the frost layer if applicable will be stripped and sub frost line soil horizons utilized for construction to achieve adequate compaction that will not settle with warming temperatures.
- Cut and fill slopes around location will be 3:1 or better to ensure surface and slope stability.
- The windrowed topsoil and any additional diversions found to be necessary are used to prevent surface sheet flow from entering location.
- The containment will have a properly constructed foundation consisting of a firm, unyielding base, smooth and free of rocks, debris, sharp edges or irregularities to prevent the liner's rupture or tear.

Other factors contributing to site stability include:

- Per 19.15.34.11 A.(7) the location is not in an area overlying a subsurface mine according to the New Mexico EMNRD Mining and Minerals Divisions database.
- This area of New Mexico is not known for underlying caves and karst features.

### **2.9. Distance to 100-Year Floodplain 19.15.34.11 A.(9)**

The recycling facility/containment is not located within a 100-year (1% annual) floodplain. As shown in Exhibit E Map 2, the project is in Zone X (area of minimal flood hazard). The nearest 100-year flood hazard area within the same watershed shown in Exhibit E Map 2 is approximately 1.5 miles west.

## **3. DESIGN AND CONSTRUCTION SPECIFICATIONS**

Pursuant to 19.15.34.12 NMAC, the following Design Plan presents the minimum standards and specifications for the design and construction of the proposed recycling containment at the North Alamito Unit A19/N17 AST Pad. The facility and recycling containment have been designed to prevent release and potential overtopping due to wave action (by wind) or rainfall. To supplement the information provided below, the manufacturers specifications for the design and construction of the aboveground containment are provided as Exhibit G.

### **3.1. Foundation Construction**

The containment AST will be constructed on DJR's North Alamito Unit A19/N17 AST Pad. The AST footprint will have a properly constructed foundation consisting of a firm, unyielding base, smooth and free of rocks, debris, sharp edges or irregularities to prevent the liner's rupture or tear. The containment will ensure confinement of produced water, to prevent releases and to prevent overtopping due to wave action or rainfall. Geotextile is used under the liner to reduce localized stress-strain or protuberances that otherwise may compromise the liner's integrity. The containment is above ground and is not subject to water run-on.

### **3.2. Liner and Leak Detection**

The containment will be Well Water Solutions and Rentals, Inc. or similar double-lined frac water tank system. These tank systems are designed to incorporate a 40-mil thickness LLDPE primary (upper) string-reinforced liner and a 30-mil LLDPE secondary (lower) string-reinforced liner. The primary liner is designed to be impervious, synthetic material that will resist deterioration by ultraviolet light, petroleum hydrocarbons, salt solutions, and acidic/alkaline solutions. Liners meet or exceed the compatibility requirements of EPA SW-846 Method 9090A. Steel bolts secure the liners to the top of the AST tank. Specifications provided by Well Water Solutions and Rentals, Inc. are attached as Exhibit G.

Liner seams are minimized and are oriented vertically up and down the containment walls, not horizontally across the containment. Factory welded seams are incorporated, where possible. Field seams, welding, and testing on the

## C-147 Registration Package

geosynthetic liners are performed by a manufacturer's qualified person. For any field welded seams, liners will overlap 4 to 6 inches and be thermally sealed. Field seams are avoided or minimized in corners and irregularly shaped areas.

At a points of discharge into, or suction from, the recycling containment, the liner is protected from excessive hydrostatic force or mechanical damage. External discharge or suction lines do not penetrate the liners.

A leak detection system is installed between the upper and lower liners of the containment and consist of a 200-mil geonet drainage layer. The leak detection system covers the bottom and sides of the containment and includes a minimum of 3 feet of freeboard. A 6-inch PVC pipe is inserted in the sump at the bottom of the containment and between the liners. Each containment is slightly sloped, with the sump placed at the location with the lowest elevation to facilitate the earliest possible leak detection. A schematic of the leak detection system is included in Exhibit G.

The sump piping is checked weekly with a water-level meter to determine if leakage is occurring through the primary liner. If water is detected in the leak detection sump, water will be removed to assess if water returns indicating a leak in the primary liner. Controls for surface water run-on are not needed due to the containment being above ground level.

### 3.3. Signage

The facility will have a sign no less than 12 inch by 24 inch with lettering not less than 2 inches in height in a conspicuous place near the facility entrance. The sign will contain the operator's name, location of the facility by quarter-quarter or unit letter, Section, Township, Range, and emergency phone numbers.

### 3.4. Entrance Protection

Please see variance request attached as Exhibit H.

With the recycling containment being an AST with 12-foot wall height, entrance to containment would have to be intentional. There is no risk of accidental entrance into the containment by wildlife or the public. The site will be maintained to prevent harm to wildlife and the public.

### 3.5. Netting

DJR will install bird netting provided by the tank manufacturer over the containment. The netting will be inspected monthly for disrepair. The containment will be inspected weekly for dead migratory birds. DJR will report dead migratory birds and/or other wildlife to the appropriate wildlife agency, surface management agency, and NMOCD.

## 4. MAINTENANCE AND OPERATING PLAN

### 4.1. Inspection Timing and Maintenance

Pursuant to 19.15.34.13 NMAC, DJR will follow the maintenance and operational requirements described below. At a minimum, DJR will perform weekly inspections on the containment and leak detection system while the containment holds fluid. DJR will maintain records and make them available for review by NMOCD.

- If fluids are found in the sump, the fluids will be sampled and then pumped out.
- DJR will remove any visible oil from the surface of the containment upon discovery.
- DJR will maintain a minimum of 3 feet of freeboard in the containment at all times.
- The injection and withdrawal of fluids from the containment shall be accomplished through a header, diverter or other hardware that prevents damage to the liner by erosion, fluid jets or impact from installation and removal of hoses or pipes.
- If a leak is discovered in the containment's primary liner above the liquid level in the containment, DJR will repair the primary liner within 48 hours, or request an extension on repair within the 48-hour time limit.
- If a leak is discovered in the containment's primary liner below the liquid level in the containment, DJR will notify the division office of the leak, remove all fluids above the leak level, and repair the primary liner within 48 hours, or request an extension on repair within the 48-hour time limit.

## C-147 Registration Package

- The facility will be operated in such a way to prevent the collection of surface water.
- An oil absorbent boom or other device will be onsite to contain an unanticipated release.
- The facility will not be used for the storage or discharge of hazardous waste.

#### 4.2. Reporting and Record Keeping

During operation of the recycling facility, DJR will keep accurate records and report monthly to NMOCD the total volume of water received for recycling, with the volume of fresh water received listed separately, and the total volume of water leaving the facility for disposition of use. Water volume totals will be submitted on NMOCD Form C-148. Accurate records identifying the sources and disposition of recycled water will be maintained during the operation of the facility and made available for review to NMOCD upon request.

#### 4.3. Cessation of Operations

DJR will consider the recycling containment to have ceased operations if less than 20% of the total fluid volume is used every 6 months following the first withdrawal of produced water for use. DJR will report cessation of operations to the appropriate NMOCD district office. If additional time is needed for closure, DJR will request an extension from the appropriate NMOCD district office prior to the expiration of the initial 6-month time period.

## 5. CLOSURE PLAN

Pursuant to 19.15.34.14 NMAC, the activities summarized below describe the closure and reclamation requirements for the North Alamito Unit A19/N17 AST Pad. Within 60 days of closure completion, DJR will submit a closure report on NMOCD Form C-147 and include required attachments to document all closure activities, sampling results, and details on backfilling, capping, or covering, where applicable.

#### 5.1. Containment Closure

DJR will remove all fluids from the facility and containment within 60 days from the date that operations cease and close the containment from use within 6 months from the date that DJR ceases operations. Alternatively, DJR can request an extension for the removal of fluids from NMOCD not to exceed an additional 2 months. DJR can also request an extension for the closure of the containment, not to exceed an additional 6 months.

DJR will remove all fluids, contents, synthetic liners, and leak detection piping and transfer these materials to an NMOCD-approved facility for disposal. All other equipment associated with the recycling containment and recycling facility will be removed from the site.

#### 5.2. Closure Soil Sampling

Once the containment is removed, DJR will test the soil beneath for contamination with a five-point composite sample which includes stained or wet soils, if any, and that sample shall be analyzed for the constituents listed in the following table:

TABLE 1. CONTAMINATED SOIL TEST CONSTITUENTS

Constituents	Test Method	Groundwater Depth 51 – 100 Feet	Groundwater Depth >100 Feet
Chloride	EPA 300.0	10,000 mg/kg	20,000 mg/kg
TPH (GRO+DRO+MRO)	EPA SW-846 Method 8015M	2,500 mg/kg	2,500 mg/kg
GRO + DRO	EPA SW-846 Method 8015M	1,000 mg/kg	1,000 mg/kg
BTEX	EPA SW-846 Method 8021B or 8260B	50 mg/kg	50 mg/kg
Benzene	EPA SW-846 Method 8021B or 8260B	10 mg/kg	10 mg/kg

---

C-147 Registration Package

---

If any contaminant concentration is higher than the parameter limits listed above, NMOCD may require additional delineation upon review of the results and DJR must receive approval before proceeding with closure. If all contaminant concentrations are less than or equal to the parameter limits listed above, then DJR can proceed to backfill with non-waste containing, uncontaminated, earthen material.

**5.3. Reclamation**

The location will be reclaimed upon completion of use in accordance with the landowner's requirements.

**EXHIBIT A. PLAT**

A

**CENTER OF PAD**  
LATITUDE: 36.215087° N  
LONGITUDE: 107.603620° W  
DATUM: NAD83

**DJR OPERATING, LLC**  
**NORTH ALAMITO UNIT #102H**  
**STAGING AREA**  
LOCATED IN THE SW/4 NW/4 OF SECTION 20,  
T23N, R7W, N.M.P.M.,  
SANDOVAL COUNTY, NEW MEXICO  
FINISHED PAD ELEVATION: 6985.6', NAVD 88  
NAU A19-2307

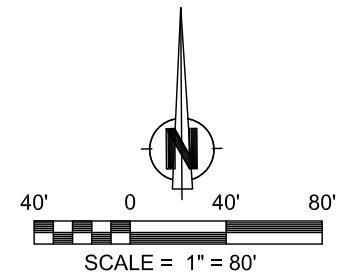

**NOTES:**

- 1.) BASIS OF BEARING: BETWEEN FOUND MONUMENTS AT THE WEST QUARTER CORNER AND THE NORTHWEST CORNER OF SECTION 20, TOWNSHIP 23 NORTH, RANGE 7 WEST, N.M.P.M., SANDOVAL COUNTY, NEW MEXICO. LINE BEARS: N 00°11'26" W A DISTANCE OF 2659.15 FEET AS MEASURED BY G.P.S. AND BASED ON THE N.M.S.P. COORDINATE SYSTEM (WEST ZONE).
- 2.) LATITUDE, LONGITUDE AND ELLIPSOIDAL HEIGHT BASED ON AZTEC CORS L1 PHASE CENTER. DISTANCES SHOWN ARE GROUND DISTANCES USING A TRAVERSE MERCATOR PROJECTION FROM A WGS84 ELLIPSOID, CONVERTED TO NAD83. NAVD88 ELEVATIONS AS PREDICTED BY GEOID09.
- 3.) LOCATION OF UNDERGROUND UTILITIES DEPICTED ARE APPROXIMATE. PRIOR TO EXCAVATION UNDERGROUND UTILITIES SHOULD BE FIELD VERIFIED. ALL CONSTRUCTION ACTIVITIES SHOULD BE FIELD VERIFIED WITH NEW MEXICO ONE-CALL AUTHORITIES AT LEAST 48 HOURS PRIOR TO CONSTRUCTION.
- 4.) T-POSTS HAVE BEEN SET TO DEFINE THE EDGE OF DISTURBANCE LIMITS WHICH ARE 50' OFFSETS FROM THE EDGE OF THE STAKED WELL PAD.

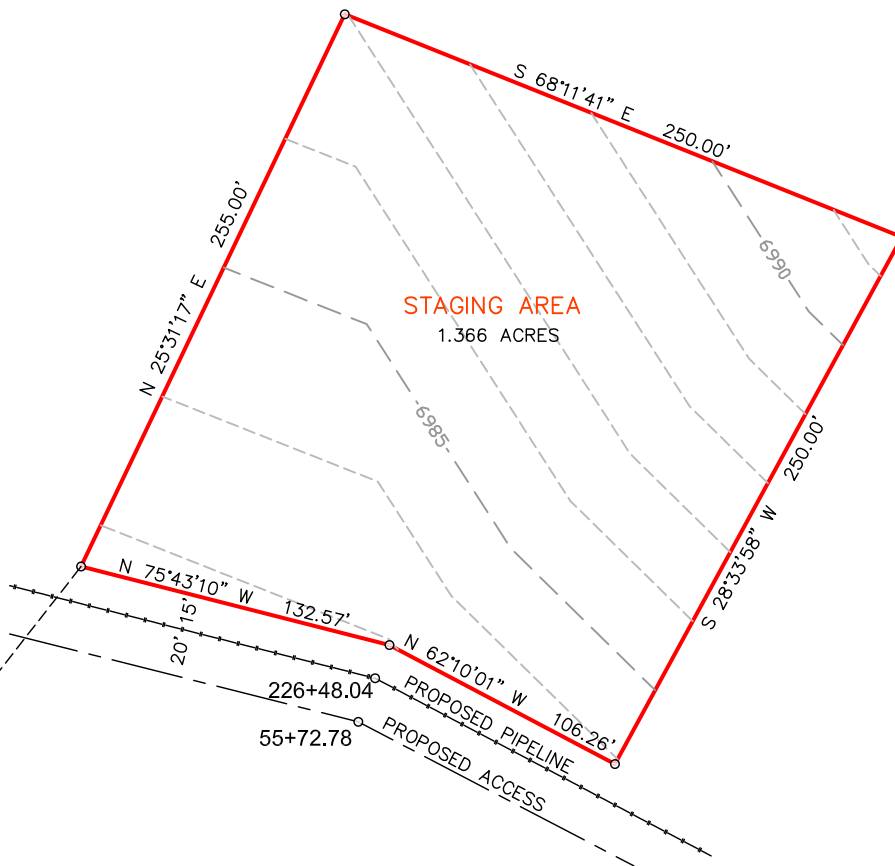

~ SURFACE OWNERSHIP ~
FEE

**TOTAL PERMITTED AREA**  
**±250' x ±250' = 1.366 ACRES**  
**SCALE: 1" = 80'**  
**DATE: 09/14/20**  
**DRAWN BY: GRR**

**NOTE:**  
CHENAULT CONSULTING, INC. IS NOT LIABLE FOR UNDERGROUND UTILITIES OR PIPELINES. CONTRACTOR SHOULD CALL ONE-CALL FOR LOCATION OF ANY MARKED OR UNMARKED, BURIED PIPELINES OR CABLES ON WELL PAD, IN CONSTRUCTION ZONE AND/OR ACCESS ROAD AT LEAST TWO (2) WORKING DAYS PRIOR TO CONSTRUCTION.

SLOPES TO BE CONSTRUCTED TO MATCH THE ORIGINAL CONTOURS AS CLOSE AS POSSIBLE.

**CCI**

**CHENAULT CONSULTING INC.**  
4800 COLLEGE BLVD.  
SUITE 201  
FARMINGTON, NM 87402  
(505)-325-7707



## **EXHIBIT B. RECYCLING FACILITY AND RECYCLING CONTAINMENT SITE DIAGRAM**

B

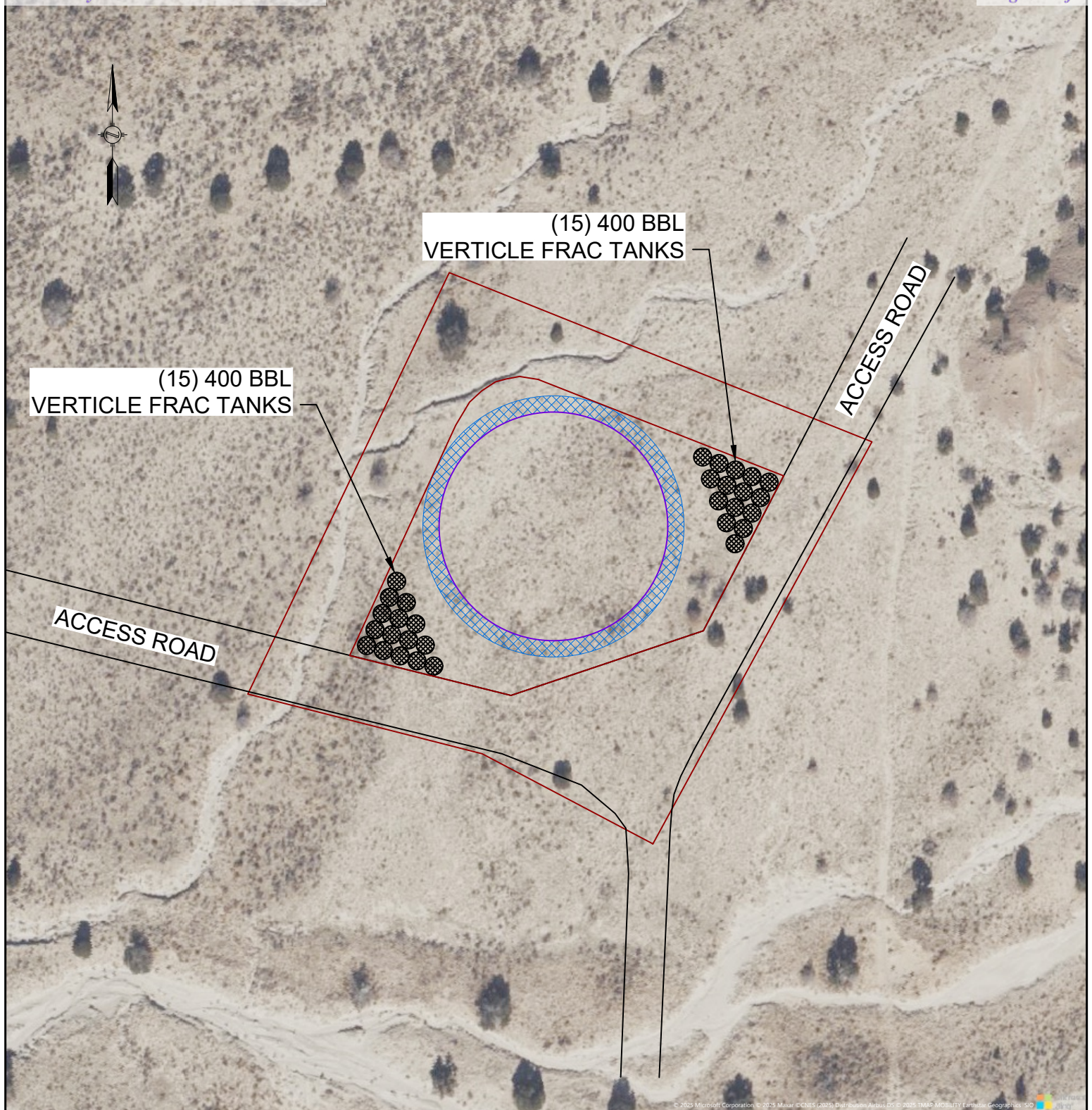

- STAGING AREA
- 43K BBL ABOVE GROUND STORAGE TANK  
163' DIAMETER
- ABOVE GROUND STORAGE TANK  
CONSTRUCTION BUFFER - 12' WIDE
- 400 BBL VERTICLE FRAC TANKS  
13' DIAMETER

**EXHIBIT "B"**

**ABOVE GROUND STORAGE TANK DIAGRAM  
NAU-A19 AST FACILITY PAD**



DRAWN BY:	KMR	DATE:	12/11/25
CHECKED BY:	CPS	DATE:	12/11/25
APPROVED BY:	BBS	DATE:	12/11/25

REV	REVISION PURPOSE	BY	DATE	PROJECT #:	COUNTY/STATE:
		CHK'D	APP'D	21129-01	SAN JUAN COUNTY, NEW MEXICO
B	ISSUED FOR INFORMATION	KMR	01/05/25	DRAWING #:	SCALE:
		CPS	01/05/25	21129-01-NAU A19-AST PAD	1"=100'
					SHEET:
					1 OF 1
					REV:
					B

## **EXHIBIT C. SURFACE OWNER NOTIFICATION**

C





## EXHIBIT D. GROUND WATER REPORT

D



**WELL RECORD & LOG**  
**OFFICE OF THE STATE ENGINEER**  
www.ose.state.nm.us

STATE ENGINEER OFFICE  
 AZTEC, NEW MEXICO

2014 MAR 13 AM 9:53

<b>1. GENERAL AND WELL LOCATION</b>	OSE POD NUMBER (WELL NUMBER) SJ 4054 Pod 1				OSE FILE NUMBER(S) SJ-4054 Pod 1					
	WELL OWNER NAME(S) Ernie or Linda Current				PHONE (OPTIONAL) 505-486-6663					
	WELL OWNER MAILING ADDRESS HCR 17 Box 409				CITY Cuba		STATE NM		ZIP 87013	
	WELL LOCATION (FROM GPS)		DEGREES LATITUDE 36*		MINUTES 13.7		SECONDS 17		* ACCURACY REQUIRED: ONE TENTH OF A SECOND	
		LONGITUDE 107*		33.1		61		* DATUM REQUIRED: WGS 84		
DESCRIPTION RELATING WELL LOCATION TO STREET ADDRESS AND COMMON LANDMARKS - PLS (SECTION, TOWNSHIP, RANGE) WHERE AVAILABLE W/2-NW/4 sec 14 twns 23N range 7W										

<b>2. DRILLING &amp; CASING INFORMATION</b>	LICENSE NUMBER WD 1111		NAME OF LICENSED DRILLER Steve Stevenson			NAME OF WELL DRILLING COMPANY Steve & Son LLC							
	DRILLING STARTED 03-02-14		DRILLING ENDED 03-03-14		DEPTH OF COMPLETED WELL (FT) 273		BORE HOLE DEPTH (FT) 273		DEPTH WATER FIRST ENCOUNTERED (FT) 197				
	COMPLETED WELL IS: <input type="radio"/> ARTESIAN <input type="radio"/> DRY HOLE <input checked="" type="radio"/> SHALLOW (UNCONFINED)							STATIC WATER LEVEL IN COMPLETED WELL (FT) 180					
	DRILLING FLUID: <input checked="" type="radio"/> AIR <input type="radio"/> MUD ADDITIVES - SPECIFY:												
	DRILLING METHOD: <input checked="" type="radio"/> ROTARY <input type="radio"/> HAMMER <input type="radio"/> CABLE TOOL <input type="radio"/> OTHER - SPECIFY:												
	DEPTH (feet bgl)		BORE HOLE DIAM (inches)		CASING MATERIAL AND/OR GRADE (include each casing string, and note sections of screen)		CASING CONNECTION TYPE		CASING INSIDE DIAM. (inches)		CASING WALL THICKNESS (inches)		SLOT SIZE (inches)
	FROM	TO											
	1	30	12-1/4			5-1/2 plastic	5"	5 DR 17	0.32				
	30	273	8-3/4	5'12 +2' to 273	213' to 233								
				20' screen									

<b>3. ANNULAR MATERIAL</b>	DEPTH (feet bgl)		BORE HOLE DIAM. (inches)		LIST ANNULAR SEAL MATERIAL AND GRAVEL PACK SIZE-RANGE BY INTERVAL		AMOUNT (cubic feet)		METHOD OF PLACEMENT		
	FROM	TO									
	0	30	12-1/4	0 to 20' quick arout seal	12 sacks	mixed & poured					

FILE NUMBER	SJ-4054 POD1	POD NUMBER		TRN NUMBER	581968
LOCATION	23N.07W.14.100				PAGE 1 OF 2





# New Mexico Office of the State Engineer

## Water Column/Average Depth to Water

(A CLW##### in the POD suffix indicates the POD has been replaced & no longer serves a water right file.) (R=POD has been replaced, O=orphaned, C=the file is closed) (quarters are smallest to largest)

(In feet)

POD Number	Code	Sub basin	County	Q64	Q16	Q4	Sec	Tws	Range	X	Y	Map	Well Depth	Depth Water	Water Column
<a href="#">SJ 00949 -S</a>		SJ	SJ	NW	SW	NE	01	22N	08W	263242.0	4006176.0 *		2647	1106	1541
<a href="#">SJ 04379 POD1</a>		SJ	SJ	NE	SW	NW	01	22N	08W	263241.6	4006175.1		2647		

Average Depth to Water: **1106 feet**

Minimum Depth: **1106 feet**

Maximum Depth: **1106 feet**

**Record Count:** 2

**Basin/County Search:**

**County:** SJ

**PLSS Search:**

**Range:** 08W

**Township:** 22N

**Section:** 01

\* UTM location was derived from PLSS - see Help

The data is furnished by the NMOSE/ISC and is accepted by the recipient with the expressed understanding that the OSE/ISC make no warranties, expressed or implied, concerning the accuracy, completeness, reliability, usability, or suitability for any particular purpose of the data.



# New Mexico Office of the State Engineer

## Water Column/Average Depth to Water

(A  
 CLW#####  
 in the POD  
 suffix  
 indicates  
 the POD has  
 been  
 replaced  
 & no longer  
 serves a  
 water right  
 file.)

(R=POD has  
 been  
 replaced,  
 O=orphaned,  
 C=the file is  
 closed)

(quarters are  
 smallest to  
 largest)

(In feet)

POD Number	Code	Sub basin	County	Q64	Q16	Q4	Sec	Tws	Range	X	Y	Map	Well Depth	Depth Water	Water Column
<a href="#">SJ01156</a>		SJ	RA	NE	NE	NW	18	23N	06W	274330.0	4012555.0 *		1500	200	1300

Average Depth to Water: **200 feet**

Minimum Depth: **200 feet**

Maximum Depth: **200 feet**

**Record Count:** 1

**Basin/County Search:**

**County:** RA

**PLSS Search:**

**Range:** 06W

**Township:** 23N

**Section:** 18

\* UTM location was derived from PLSS - see Help

The data is furnished by the NMOSE/ISC and is accepted by the recipient with the expressed understanding that the OSE/ISC make no warranties, expressed or implied, concerning the accuracy, completeness, reliability, usability, or suitability for any particular purpose of the data.



# New Mexico Office of the State Engineer

## Water Column/Average Depth to Water

(A CLW##### in the POD suffix indicates the POD has been replaced & no longer serves a water right file.) (R=POD has been replaced, O=orphaned, C=the file is closed) (quarters are smallest to largest)

(In feet)

POD Number	Code	Sub basin	County	Q64	Q16	Q4	Sec	Tws	Range	X	Y	Map	Well Depth	Depth Water	Water Column
<a href="#">SJ01507</a>		SJ	RA	SW	SW	SE	10	23N	07W	269889.0	4013098.0 *		1709	900	809

Average Depth to Water: **900 feet**

Minimum Depth: **900 feet**

Maximum Depth: **900 feet**

**Record Count:** 1

**Basin/County Search:**

**County:** RA

**PLSS Search:**

**Range:** 07W

**Township:** 23N

**Section:** 10

\* UTM location was derived from PLSS - see Help

The data is furnished by the NMOSE/ISC and is accepted by the recipient with the expressed understanding that the OSE/ISC make no warranties, expressed or implied, concerning the accuracy, completeness, reliability, usability, or suitability for any particular purpose of the data.



# New Mexico Office of the State Engineer Water Column/Average Depth to Water

(A CLW##### in the POD suffix indicates the POD has been replaced & no longer serves a water right file.) (R=POD has been replaced, O=orphaned, C=the file is closed) (quarters are smallest to largest)

(In feet)

POD Number	Code	Sub basin	County	Q64	Q16	Q4	Sec	Tws	Range	X	Y	Map	Well Depth	Depth Water	Water Column
<a href="#">SJ 04195 POD1</a>		SJ	SJ		NW	SW	11	23N	08W	261123.2	4013544.4		700	290	410

Average Depth to Water: **290 feet**

Minimum Depth: **290 feet**

Maximum Depth: **290 feet**

**Record Count:** 1

**Basin/County Search:**

**County:** SJ

**PLSS Search:**

**Range:** 08W

**Township:** 23N

**Section:** 11

\* UTM location was derived from PLSS - see Help







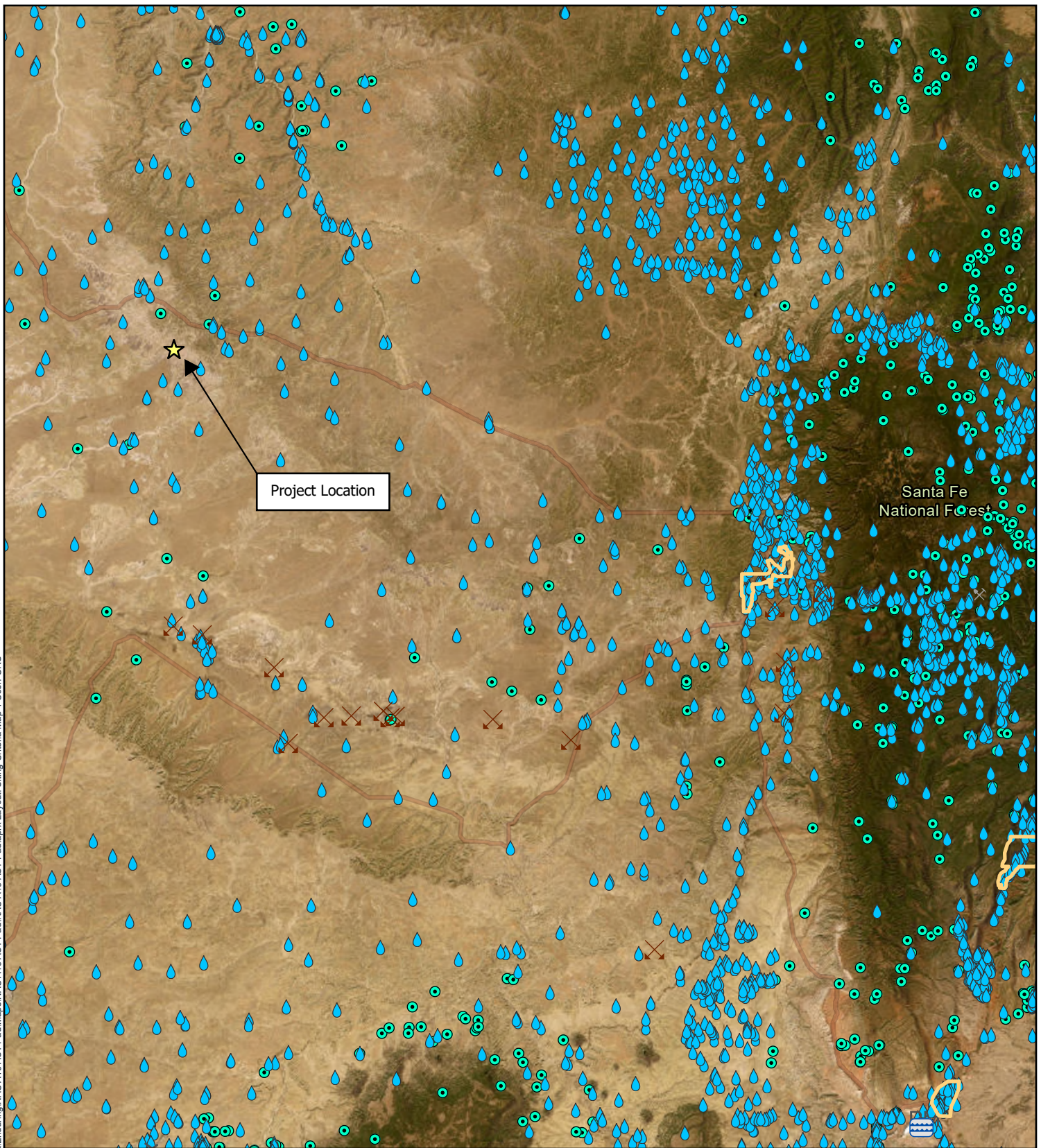

The data is furnished by the NMOSE/ISC and is accepted by the recipient with the expressed understanding that the OSE/ISC make no warranties, expressed or implied, concerning the accuracy, completeness, reliability, usability, or suitability for any particular purpose of the data.

## EXHIBIT E. SITING CRITERIA MAPS

E



Barr Footer: ArcGISPro, 2/25/2026 3:52 PM File: I:\Client\Enduring\NAU A19 AST Pad\Maps\NAU A19 AST Pad.aprx Layout: Siting Criteria Map 1 User: ORS

-  Incorporated Places
- Registered Mines**
-  Aggregate, Stone etc.
-  Coal
-  Gypsum
-  Humate
- PM**  Pumice
-  Office of the State Engineer - Point of Diversion
-  Spring/Seep

North Alamito Unit A19/N17  
 Aboveground Storage Tank Pad  
 DJR Operating, LLC  
 Map 1  
**Siting Criteria**

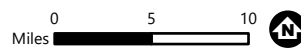

Sources: Barr Engineering, DJR Operating, LLC, ESRI

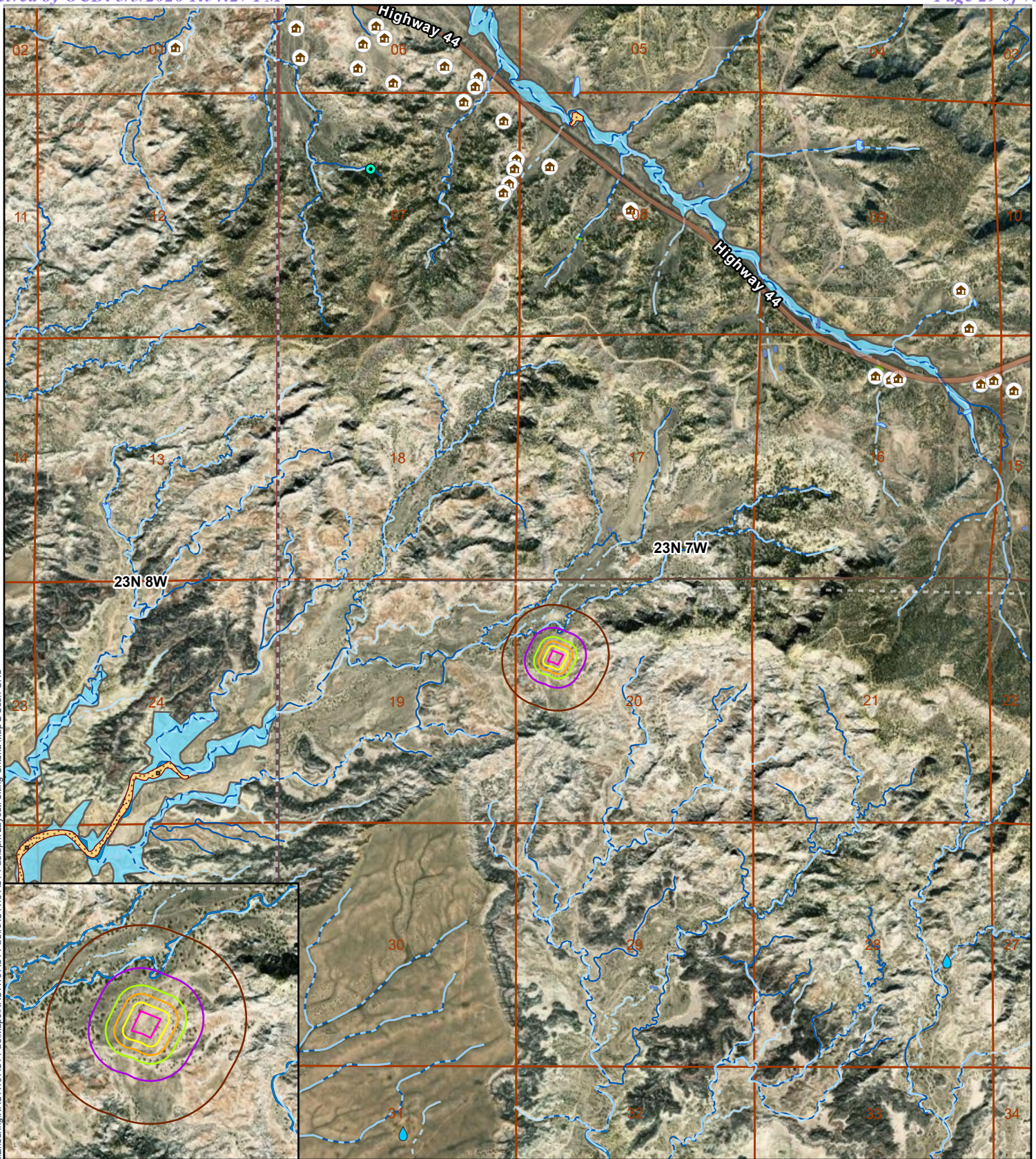

Barr Footer: ArcGISPro\_2/25/2026 3:38 PM File: I:\Client\Enduring\NAU A19 AST Pad\Maps\NAU A19 AST Pad.aprx Layout: Siting Criteria Map 2 User: QRS

- Staging Area
- 100-Foot Wide Buffer
- 200-Foot Wide Buffer
- 300-Foot Wide Buffer
- 500-Foot Wide Buffer
- 1000-Foot Wide Buffer
- Township
- Section
- Office of the State Engineer - Point of Diversion
- Residence
- National Hydrography Dataset
- Spring/Seep
- Waterbody
- Lake/Pond
- Area
- Wash
- Flowline
- River/Stream: Intermittent
- National Wetlands Inventory (NWI)
- Freshwater Emergent Wetland
- Freshwater Pond
- Riverine
- National Flood Hazard (NM)
- Special Flood Hazard Area
- Area of Minimal Flood Hazard (Zone X)

North Alamito Unit A19/N17  
 Aboveground Storage Tank Pad  
 DJR Operating, LLC  
 Map 2  
**Siting Criteria**

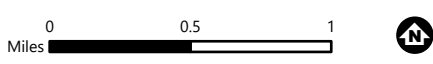

Sources: Barr Engineering, DJR Operating, LLC, ESRI

**EXHIBIT F. AQUATIC RESOURCES DELINEATION TECHNICAL  
MEMORANDUM**

F

# Technical Memorandum

**To:** Casey Haga, Enduring Resources IV, LLC  
**From:** Olivia Sheldon  
**Subject:** Aquatic Resources Delineation  
**Date:** February 25, 2026  
**Project:** North Alamito Unit A19/N17 Aboveground Storage Tank Pad

DJR Operating, LLC (DJR) retained Barr Engineering Co. (Barr) to conduct an aquatic resources delineation survey for the North Alamito Unit A19/N17 Aboveground Storage Tank (AST) Pad located in the SW ¼ NW ¼ of Section 20, Township 23 North, Range 7 West, New Mexico Principal Meridian, Sandoval County (Map 1). The North Alamito Unit A19/N17 AST Pad is irregularly shaped encompassing 1.366 acres. The center coordinates for the site are 36.215109° N, -107.603615° W, North American Datum 1983 Zone 13 North. The site is located on private land. The survey area encompassed the North Alamito Unit A19/N17 AST Pad and a 500-foot buffer area surrounding the site.

The purpose of the aquatic resources delineation survey was to identify the potential presence and extent of features that may be considered jurisdictional Waters of the United States (WOTUS) under Section 404 of the Clean Water Act (CWA), as amended (33 United States Code §1251 et seq.). The United States Army Corps of Engineers (USACE) administers the CWA Section 404. DJR is applying for a permit to transport, store, and recycle produced water for reuse in drilling and completing oil/natural gas wells per Title 19, Chapter 15, Part 34 (19.15.34) of the New Mexico Administrative Code (NMAC).

This technical memorandum reports the survey findings and aquatic resources that may be considered jurisdictional WOTUS, including wetlands and aquatic resources exhibiting an ordinary high-water mark (OHWM) following the USACE methods and guidance.

## 1 Regulatory Framework

### 1.1 Federal

The USACE's definition of WOTUS includes traditional navigable waters, wetlands adjacent to traditional navigable waters, and relatively permanent waters defined as tributaries and wetlands adjacent to navigable waters that have a continuous surface connection and standing or continuously flowing bodies of water (EPA 2025). The USACE defines wetlands as special aquatic sites "that are inundated or saturated by surface or groundwater at a frequency and duration sufficient to support, and under normal circumstances do support, a prevalence of vegetation typically adapted for life in saturated soil conditions" (USACE 1987).

The USACE has the regulatory authority and discretion to determine the jurisdictional status of aquatic resources at a given site.

### 1.2 New Mexico State

19.15.34 NMAC applies to the transportation, disposal, recycling, reuse, or the direct surface or subsurface disposition by use of water produced or used in connection with the development or production of oil, gas, or both; in road construction or maintenance, or other construction; and the

To: Casey Haga, Enduring Resources IV, LLC  
From: Olivia Sheldon  
Subject: Aquatic Resources Delineation  
Date: February 25, 2026  
Page: 2

---

generation of electricity or other industrial processes. 19.15.34 NMAC also applies to transporting drilling fluids and liquid oil field waste.

Depending on the proposed activity, a permit or registration (Form C-147) for recycling and reuse of produced water, drilling fluids, and liquid oil field waste, including recycling containment, is required by the New Mexico Energy, Minerals, and Natural Resources Department Oil Conservation Division (OCD). Form C-147 siting criteria require that recycling containment not be located:

- where groundwater is less than 50 feet below the bottom of the containment;
- within 300 feet of a continuously flowing watercourse or 200 feet of any other significant watercourse or lakebed, sinkhole, or playa lake (measured from the OHWM);
- within 500 feet of a spring or freshwater well used for domestic or stock watering purposes in existence at the time of the initial registration;
- within incorporated municipal boundaries or within a defined municipal freshwater well field covered by a municipal ordinance adopted under Section 3-27-3 New Mexico Statutes 1978, as amended, unless the municipality specifically approves the recycling containment in writing;
- within 500 feet of a wetland; or
- within a 100-year floodplain.

Watercourse is defined in 19.15.2.7 NMAC as “a river, creek, arroyo, canyon, draw, or wash or other channel having definite banks and bed with visible evidence of the occasional flow of water.” Wetlands are defined in 19.15.2.7 NMAC as “areas that are inundated or saturated by surface or groundwater at a frequency and duration sufficient to support, and under normal circumstances do support, a prevalence of vegetation typically adapted for life in saturated soil conditions in New Mexico.” The term “significant” is not defined in NMAC.

## 2 Methods

Before initiating fieldwork, Barr completed a desktop evaluation of the survey area using the best available information, including the following:

- US Geological Survey (USGS) 7.5-minute topographic quadrangles for local and regional environmental settings relevant to the project area's surface waters, wetlands, and contours.
- National Hydrography Dataset (NHD) for mapped "bluelines"—perennial, intermittent, and ephemeral drainages—and other water features in the project area.
- National Wetlands Inventory (NWI) maps generated by the US Fish and Wildlife Service (USFWS) for the project area.
- Natural Resources Conservation Service (NRCS) Web Soil Survey information for the project area.
- Floodplain data from the Federal Emergency Management Agency (FEMA) Mapping Information Platform.

To: Casey Haga, Enduring Resources IV, LLC  
From: Olivia Sheldon  
Subject: Aquatic Resources Delineation  
Date: February 25, 2026  
Page: 3

---

- ESRI ArcGIS Online World Imagery (ESRI 2025).

## 2.1 Wetlands

The survey area was evaluated for the presence of wetlands using guidance provided in the *1987 Corps of Engineers Wetlands Delineation Manual* (USACE 1987) and the *Regional Supplement to the USACE Wetland Delineation Manual: Arid West Region* (USACE 2008). Under the delineation procedures identified in these manuals, an area must exhibit characteristic wetland hydrology, hydric soils, and hydrophytic vegetation to be considered a wetland. Additionally, the USACE stipulates that all three conditions must be met under normal circumstances for an area to be designated as a wetland (USACE 1987).

## 2.2 Non-Wetland Waters

Barr biologists evaluated the presence/absence and characteristics of the OHWM along all non-wetland water features (e.g., streams, creeks, and ponds) mapped during the pre-field desktop evaluation. Guidance from *A Field Guide to the Identification of the Ordinary High-Water Mark in the Arid West Region of the Western United States* (USACE 2008) was used to identify drainage channel lateral limits. General characteristics for determining the OHWM in the project area were identified using guidance provided in USACE RGL 05-05 (USACE 2005).

For stream features exhibiting an OHWM, Barr conducted an aquatic resources inventory in the field using the *User Manual for a Beta Streamflow Duration Assessment Method for the Arid West of the United States* (Mazor et al. 2023). The Streamflow Duration Assessment Method (SDAM) is a rapid, field-based method for determining flow duration class at the reach scale, eliminating the need for long-term hydrologic data. The SDAM may inform a range of activities where information on streamflow duration is beneficial, including specific jurisdictional determinations under the CWA; however, the SDAM is not a jurisdictional determination (Mazor et al. 2023). The method is specific to the Arid West Region and relies on five indicators to determine stream flow classification: perennial, intermittent, ephemeral, at least intermittent, and need more information. Biologists recorded the status of these five indicators on a field form for every surface water feature in the survey area with an OHWM.

A handheld global positioning system (GPS) unit with submeter accuracy was used to digitally record sampling points and any wetland or other features in the survey area. Geographic information system (GIS) software was used to analyze recorded features, calculate areas, and generate maps of the survey area.

## 3 Results

### 3.1 Desktop Review

The North Alamito Unit A19/N17 AST Pad is in the Escavada Wash watershed (Hydrologic Unit Code 1408010603) (USGS 2021) and can be found on the Lybrook, New Mexico U.S. Geological Survey 7.5-minute quadrangle. Two soil units occur in the survey area— Vessilla-Menefee-Orlie association, 0 to 30 percent slopes and Badland. Neither soil unit is listed as a hydric soil for Sandoval County, New Mexico (NRCS 2026).

The survey area falls within a FEMA Flood Zone X, an area of minimal flood hazard. No FEMA-designated 100-year flood zones are located within the survey area (FEMA 2025). The desktop review

To: Casey Haga, Enduring Resources IV, LLC  
From: Olivia Sheldon  
Subject: Aquatic Resources Delineation  
Date: February 25, 2026  
Page: 4

---

did not identify any NWI wetlands or perennial waters within 500 feet of the project. The review did identify one NHD flowline within the 500-foot buffer (USGS 2016; USFWS 2026).

### 3.2 Field Survey

Barr biologist John Dodge conducted the aquatic resources delineation survey on January 26, 2026. The field survey verified the presence or absence of any wetlands or other surface water features in the survey area.

## 4 Conclusions

One drainage with an OHWM was observed within 200 feet of the North Alamito Unit A19/N17 AST Pad. Based on the SDAM performed by John Dodge and verified using the SDAM online tool, this drainage would be considered ephemeral and not a jurisdictional WOTUS. Two points were sampled as shown on Map 2 and in Photographs 1 and 2. The SDAM online reports for the sample sites are attached.



**Photograph 1. Sample point #3 looking upstream**

To: Casey Haga, Enduring Resources IV, LLC  
From: Olivia Sheldon  
Subject: Aquatic Resources Delineation  
Date: February 25, 2026  
Page: 5

---



**Photograph 2. Sample point #4 looking upstream**

No wetlands are located within 500 feet of the North Alamito Unit A19/N17 AST Pad. No FEMA 100-year flood zones are in the survey area.

Based on the regulatory framework (Section 1), evaluation of the survey area, and the USACE Albuquerque District's current policies regarding jurisdictional determinations, it is Barr's professional opinion that under the current CWA rule, there are no features present in the survey area that would be considered jurisdictional WOTUS.

These conclusions are based on Barr's professional opinion. The USACE has the final regulatory authority to determine the presence and extent of jurisdictional WOTUS. The NMOCD has the final regulatory authority for determining the presence of continuously flowing watercourses, significant watercourses, or wetlands, as well as their boundaries, for the purposes of permitting and registration applicable to 19.15.34 NMAC.

## 5 References

ESRI. 2026. World Imagery. Available online at: [https://services.arcgisonline.com/ArcGIS/rest/services/World\\_Imagery/MapServer](https://services.arcgisonline.com/ArcGIS/rest/services/World_Imagery/MapServer).

Federal Emergency Management Agency (FEMA). 2025. Flood map service center. U.S. Department of Homeland Security. Washington, D. C. Available online at: <https://msc.fema.gov/portal/>. Accessed February 2026.

Mazor, R. D., B. Topping, T. L. Nadeau, K. M. Fritz, J. Kelso, R. Harrington, W. Beck, K. McCune, H. Lowman, A. Allen, R. Leidy, J. T. Robb, and G. C. L. David. 2023. User Manual for a Beta Streamflow Duration Assessment Method for the Arid West of the United States. Version 1.1. Document No. EPA 800-5-21001.

To: Casey Haga, Enduring Resources IV, LLC  
From: Olivia Sheldon  
Subject: Aquatic Resources Delineation  
Date: February 25, 2026  
Page: 6

---

Natural Resource Conservation Service (NRCS). 2026. Web Soil Survey. [Online digital data.] Soil Survey Staff, Natural Resources Conservation Service, United States Department of Agriculture. Available at: <http://websoilsurvey.sc.egov.usda.gov/>.

U.S. Army Corps of Engineers (USACE). 1987. Corps of Engineers Wetlands Delineation Manual. Technical Report Y-87-1, Environmental Laboratory, US Army Corps of Engineers Waterways Experiment Station. Vicksburg, Mississippi.

USACE. 2005. Regulatory Guidance Letter No. 05-05, Ordinary High Water Mark Identification. December 7, 2005.

USACE. 2008. Regional Supplement to the Corps of Engineers Wetland Delineation Manual: Arid West Region (Version 2.0), edited by J. S. Wakeley, R. W. Lichvar, and C. V. Noble. ERDC/EL TR-08-28. Vicksburg, Mississippi: U.S. Army Engineer Research and Development Center.

U.S. Environmental Protection Agency (EPA). 2025. Current Implementation of Waters of the United States. Available at: <https://www.epa.gov/wotus/current-implementation-waters-united-states>. Accessed July 2025.

U.S. Fish and Wildlife Service (USFWS). 2025. National Wetlands Inventory. U.S. Fish and Wildlife Service Ecological Services. Available at: <https://www.fws.gov/program/national-wetlands-inventory>. Accessed July 2025.

U.S. Geological Survey (USGS). 2016. National Hydrography Dataset. Available at: <http://nhd.usgs.gov/index.html>. Accessed February 2026.

USGS. 2021. Watershed Boundary Dataset. Available at: <https://www.usgs.gov/national-hydrography/watershed-boundary-dataset>. Accessed February 2026.





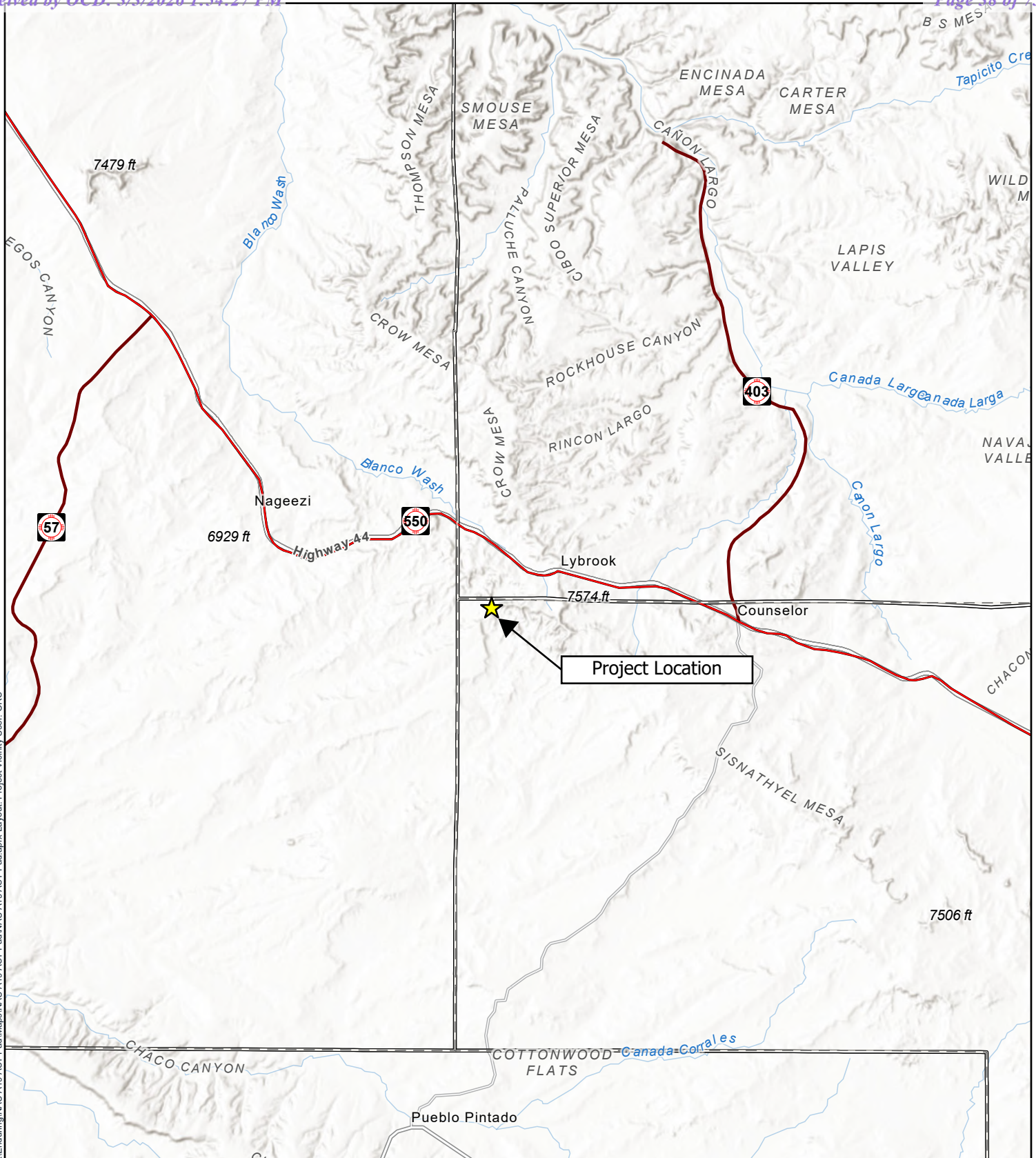

## **Attachment A**

### **Maps**



Barr Footer: ArcGISPro, 2/25/2026 11:38 AM File: I:\Client\Engineering\NAU A19 AST Pad\Maps\NAU A19 AST Pad.aprx Layout: Project Vicinity User: ORS

-  State Route
-  U.S. Highway
-  County Boundary
-  State Boundary

North Alamito Unit A19 N17  
Aboveground Storage Tank Pad  
DJR Operating, LLC

**Project Vicinity**

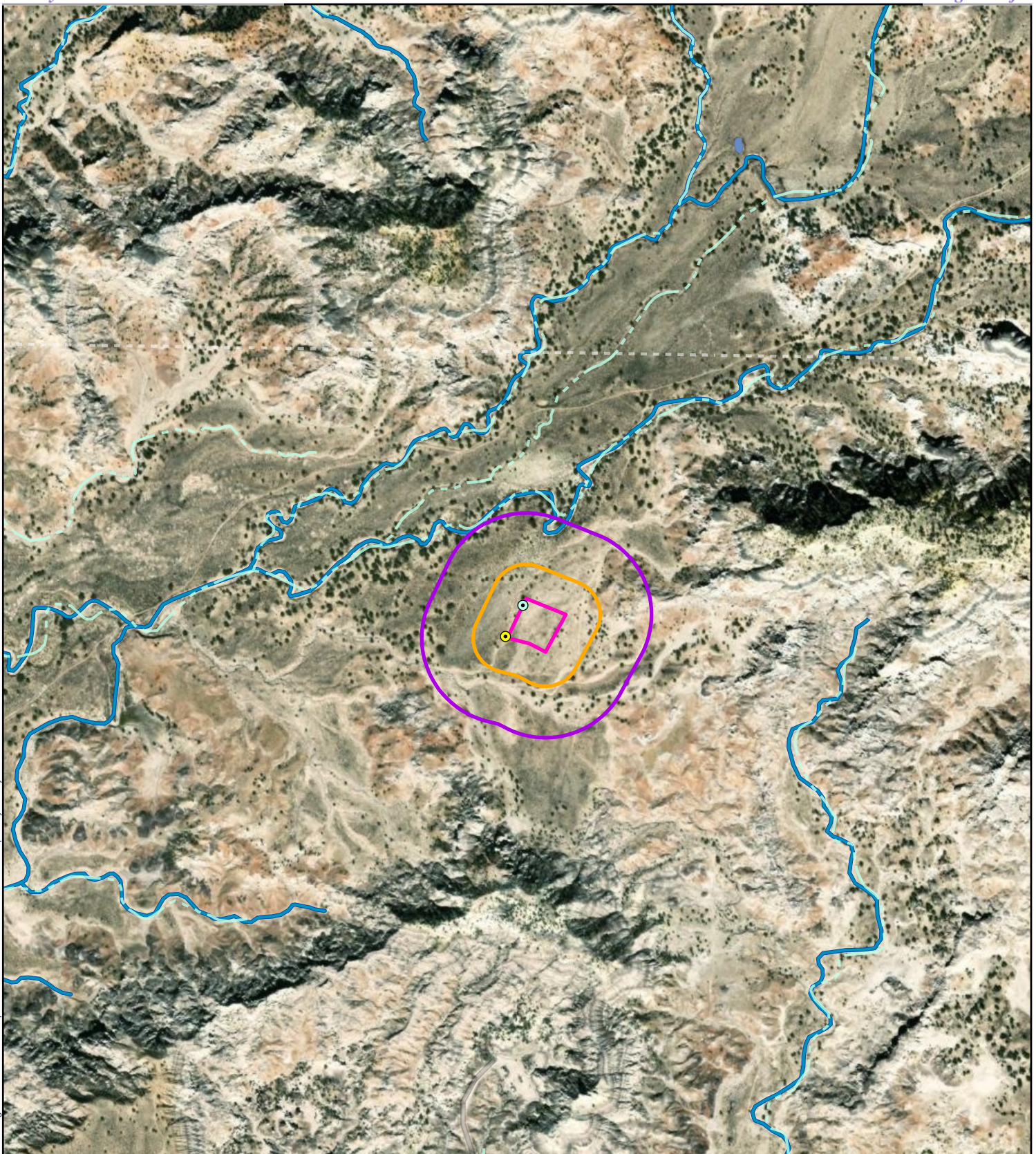

Barr Footer: ArcGISPro\_2/24/2026 10:36 AM File: I:\Client\Erduing\NAU A19 AST Pad\Maps\NAU A19 AST Pad.aprx Layout: Layout User.ors

Stream Duration Assessment Data Points

- Data Point 3
- Data Point 4
- Staging Area
- 200-Foot Wide Buffer

500-Foot Wide Buffer

- National Hydrography Dataset: Flowline
- River/Stream: Intermittent
- National Wetland Inventory
- Freshwater Pond
- Riverine

North Alamito Unit A19/N17  
Aboveground Storage Tank Pad  
DJR Operating, LLC

**Aquatic Resources  
Inventory**



# Streamflow Duration Assessment Method Report

SDAM Version 3.0.1 Release Date: October 2025

<https://www.epa.gov/streamflow-duration-assessment>

Visit date: 2026-01-26

Report generated date: 2026-02-24

Project name: North Alamito Unit A19 N17

Site code: NAU-3

Arid West SDAM classification: EPHEMERAL

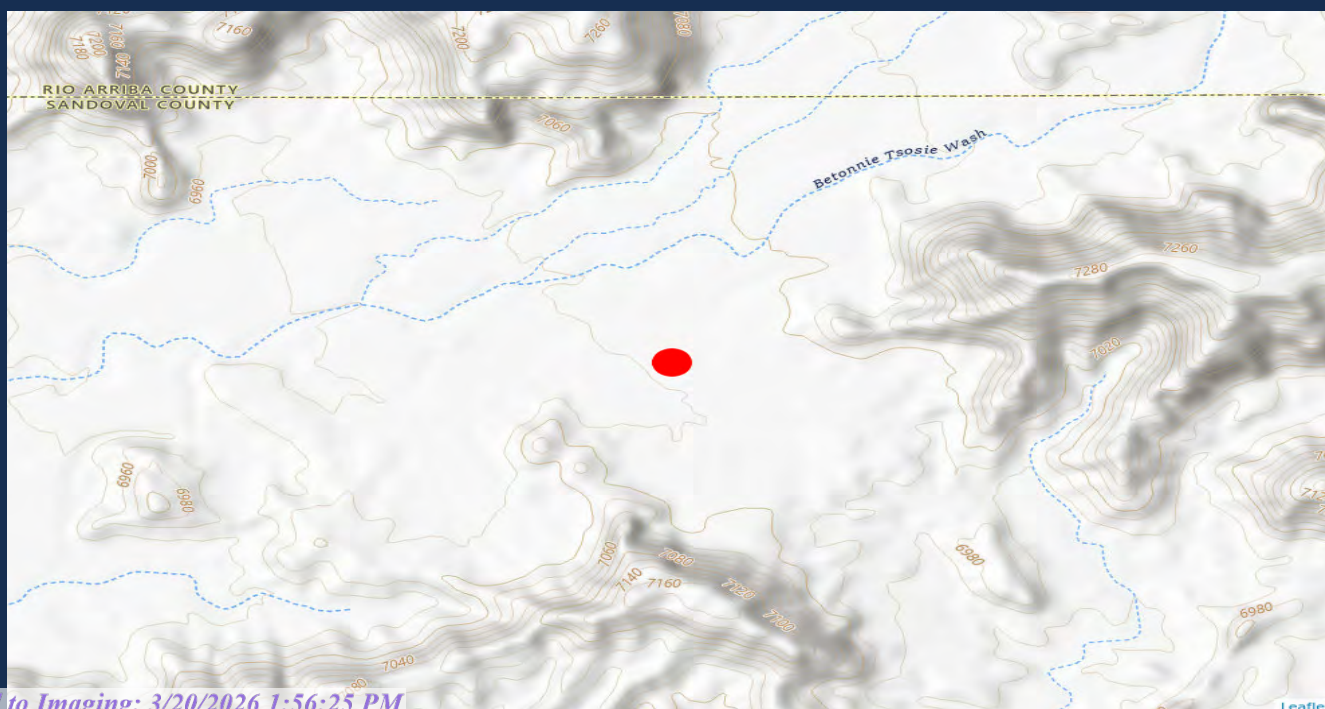
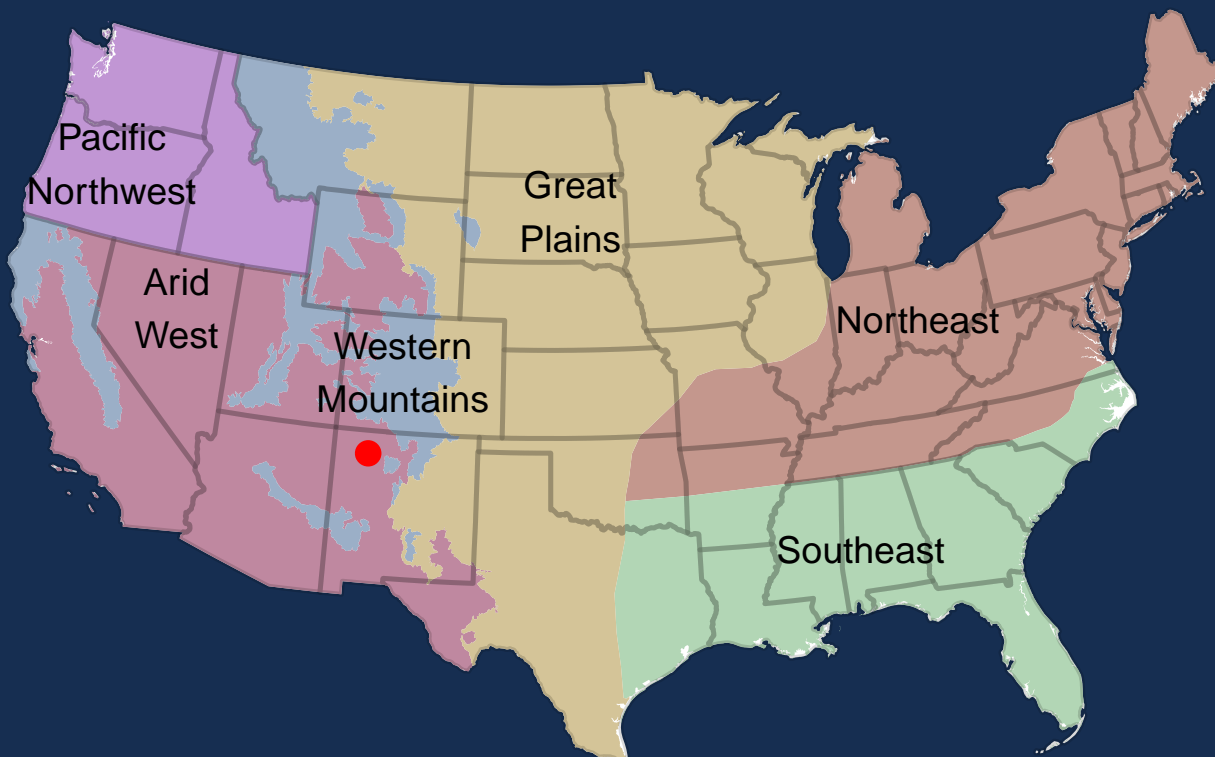

## **General site information**

Project name or number: North Alamito Unit A19 N17

Site code or identifier: NAU-3

Regional SDAM: Arid West

Adjacent SDAM Regions within 10 miles: None

Assessor(s): John Dodge

Waterway name:

Visit date: 2026-01-26

Current weather conditions: Clear/Sunny

Notes on current or recent weather conditions: 30 degrees Fahrenheit and 5-10 mile per hour winds.

Location: 36.2149327, -107.6042398

Surrounding land use within 100 m: Other Natural

Notes on land use: Surrounded by badland terrace mesa with narrow canyon terrain.

Description of reach boundaries: Surrounded by badland terrace mesa with narrow canyon terrain.

Assessment reach length (m): 4

Disturbed or difficult conditions: Other (explain in notes)

Notes on disturbances or difficult site conditions:

## **Observed hydrology**

Percent of reach with surface flow: 0

Percent of reach with surface and sub-surface flows: 0

Number of isolated pools: 0

Notes on observed hydrology: No hydrology observed.

## **Site photos**

Top of reach looking downstream:



Middle of reach looking upstream:



Middle of reach looking downstream:



Bottom of reach looking upstream:



## Site sketch

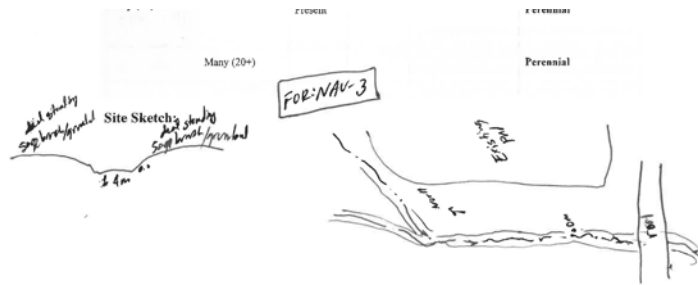

## Indicators

**Mean bankfull channel width (m): 3.4**

Notes on mean bankfull channel width:

Mean bankfull channel width photos and descriptions:



Description:



Description:

**Perennial indicator taxa: No perennial indicator taxa detected**

Aquatic macroinvertebrates in assessment area: Aquatic macroinvertebrates absent

Notes on aquatic macroinvertebrates:

Macroinvertebrate photos and photo descriptions:

**Slope (to the nearest half-percent): 1**

Notes about slope:

SDAM Version 3.0.1 October 2025, Date of site visit: 2026-01-26

Page 6 of 9

No notes about slope.

Slope photos and descriptions:

**Number of hydrophytic plant species: 0**

Vegetation in assessment area:

Notes on hydrophytic plants:

No hydrophytic vegetation.

Hydrophyte photos and photo descriptions:

**Prevalence of upland rooted plants in streambed: 1.5**

Notes about upland rooted plants:

Upland vegetation on channel banks.

Upland rooted plants photos and descriptions:

**Algal cover: Not Detected**

Check here if algae exclusively appears to have been deposited from an upstream source, and no local growth is evident: Not checked

Notes about algal cover:

No algal cover.

Algal cover photos and descriptions:

**Differences in vegetation: 0 (Poor) No compositional or density differences in vegetation are present between the banks and the adjacent uplands.**

Notes about differences in vegetation:

All vegetation is upland.

Vegetation differences photos and descriptions:

**Riffle-pool sequence: 0 (Poor) No riffle-pool sequences observed.**

Notes about riffle-pool sequence:

No riffle-pool sequences.

Riffle-pool photos and descriptions:

---

## Supplemental information

Additional notes about the assessment:

Supplemental information photos and descriptions:

---

**Arid West SDAM classification**  
**EPHEMERAL**

---

**SDAM resources**

---

**End of Report**

# Streamflow Duration Assessment Method Report

SDAM Version 3.0.1 Release Date: October 2025

<https://www.epa.gov/streamflow-duration-assessment>

Visit date: 6-08-19

Report generated date: 2026-02-24

Project name: North Alamito Unit A19 N17

Site code: NAU-4

Arid West SDAM classification: EPHEMERAL

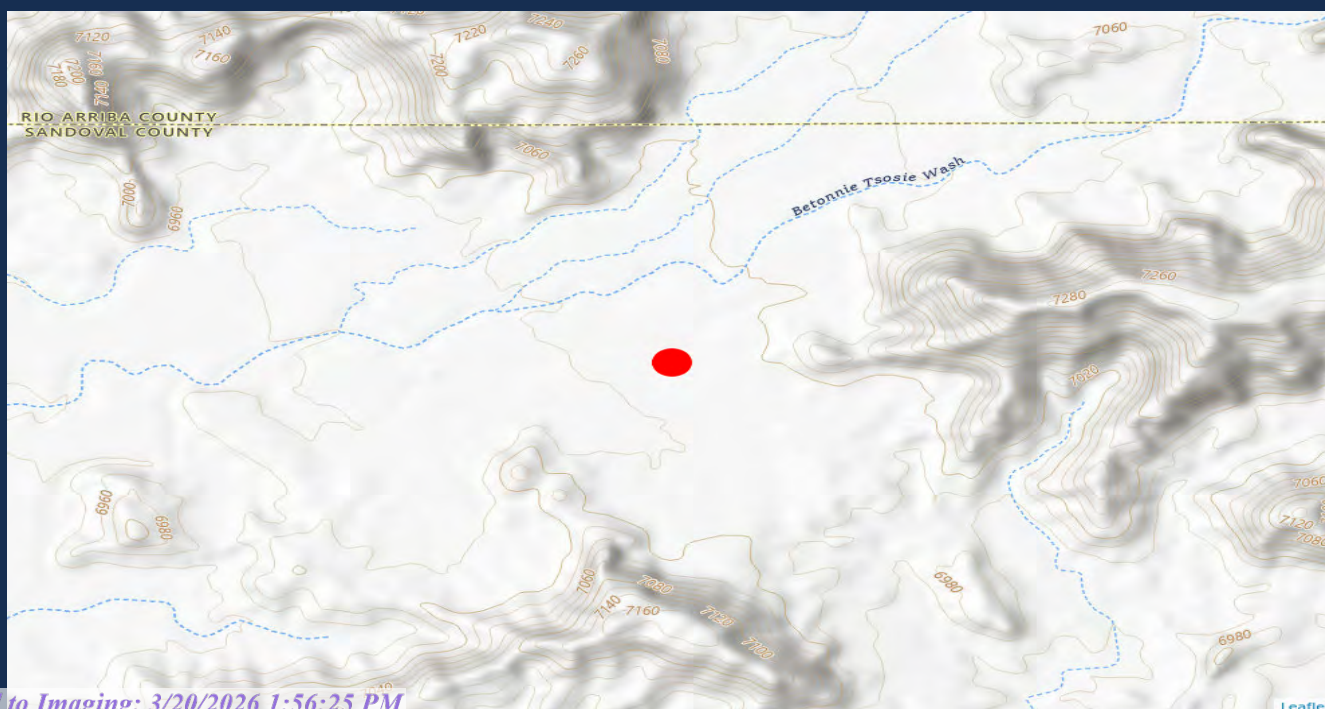
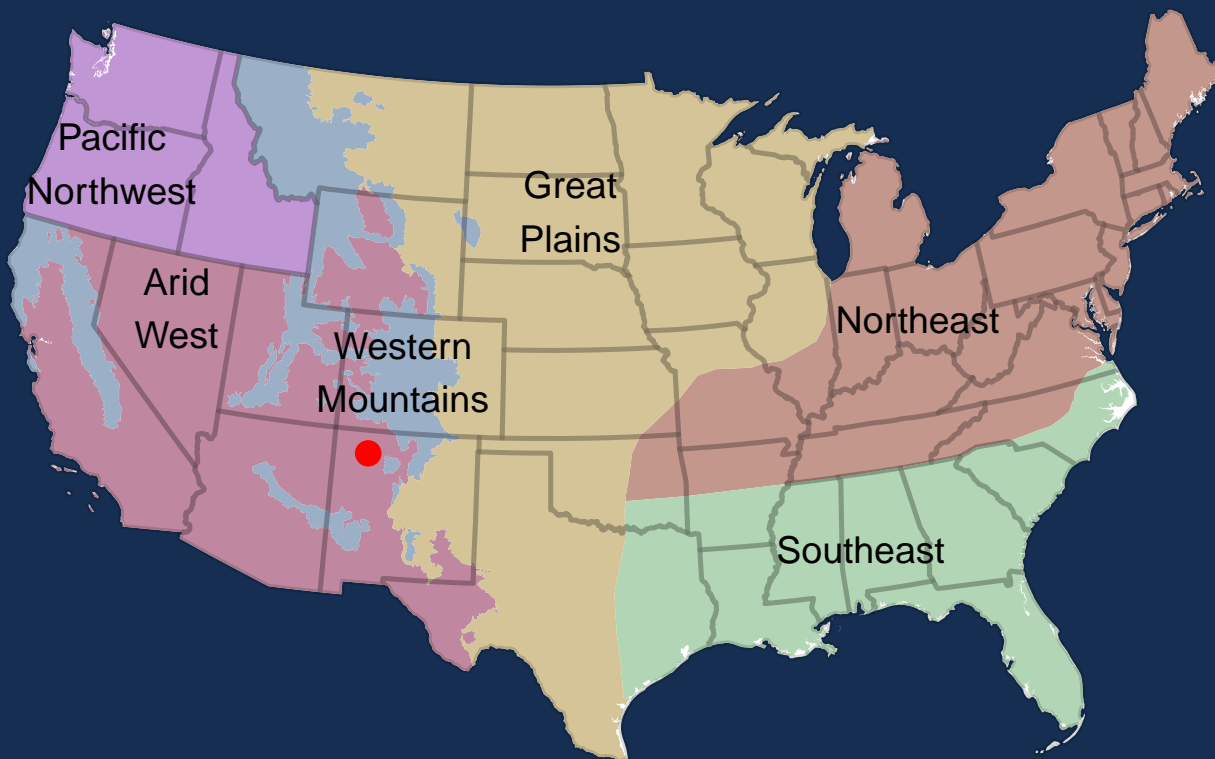

## **General site information**

Project name or number: North Alamito Unit A19 N17

Site code or identifier: NAU-4

Regional SDAM: Arid West

Adjacent SDAM Regions within 10 miles: None

Assessor(s): John Dodge

Waterway name:

Visit date: 6-08-19

Current weather conditions: Clear/Sunny

Notes on current or recent weather conditions: 30 degrees Fahrenheit and 5 to 10 mile per hour winds.

Location: 36.215431, -107.6038932

Surrounding land use within 100 m: Other Natural

Notes on land use:

Description of reach boundaries: Surrounded by badland terrace mesa with narrow canyon terrain.

Assessment reach length (m): 40

Disturbed or difficult conditions: Other (explain in notes)

Notes on disturbances or difficult site conditions: Adjacent to existing well site perimeter berm.

## **Observed hydrology**

Percent of reach with surface flow: 0

Percent of reach with surface and sub-surface flows: 0

Number of isolated pools: 0

Notes on observed hydrology: No hydrology observed.

## **Site photos**

Top of reach looking downstream:



Middle of reach looking upstream:

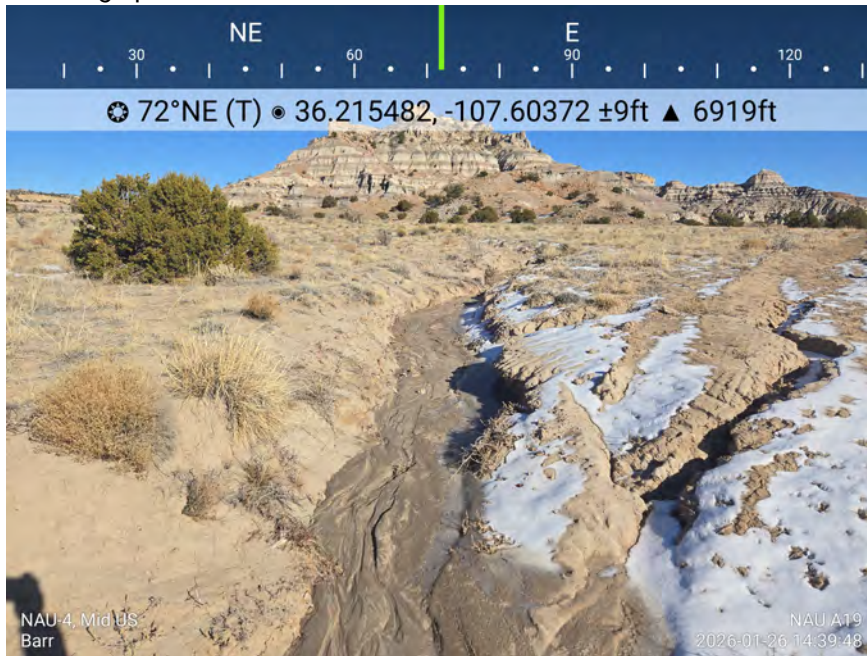

Middle of reach looking downstream:



Bottom of reach looking upstream:



## Site sketch



## Indicators

**Mean bankfull channel width (m): 3.4**

Notes on mean bankfull channel width:

Mean bankfull channel width photos and descriptions:



Description:

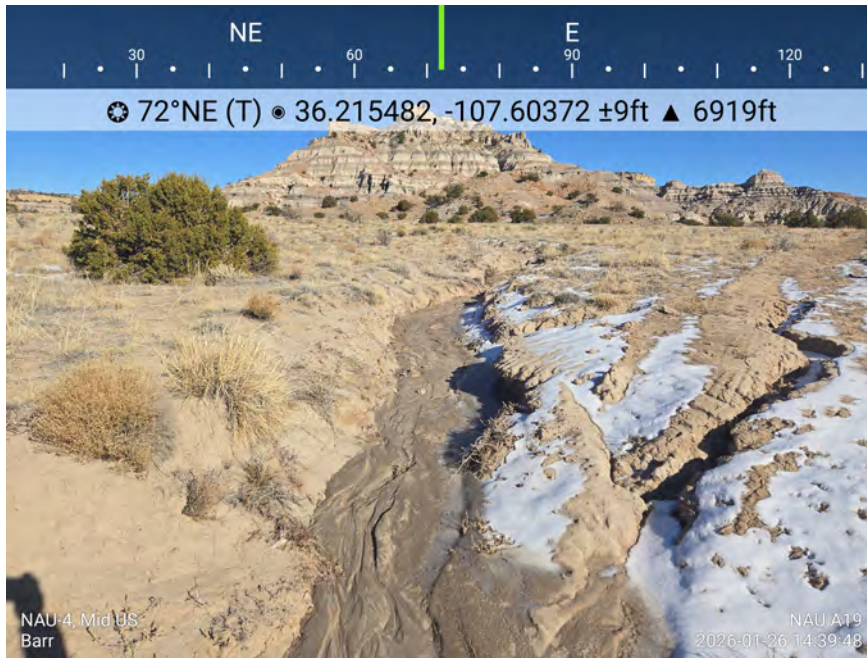

Description:

**Perennial indicator taxa: No perennial indicator taxa detected**

Aquatic macroinvertebrates in assessment area: Aquatic macroinvertebrates absent

Notes on aquatic macroinvertebrates:

Macroinvertebrate photos and photo descriptions:

**Slope (to the nearest half-percent): 1**

Notes about slope:

SDAM Version 3.0.1 October 2025, Date of site visit: 6-08-19

Page 6 of 9

No notes about slope.

Slope photos and descriptions:

**Number of hydrophytic plant species: 0**

Vegetation in assessment area: vegetation absent

Notes on hydrophytic plants:

Hydrophyte photos and photo descriptions:

**Prevalence of upland rooted plants in streambed: 2 (Moderate) There are a few rooted upland plants present within the streambed/thalweg.**

Notes about upland rooted plants:

Upland rooted plants

Upland rooted plants photos and descriptions:

**Algal cover: Not Detected**

Check here if algae exclusively appears to have been deposited from an upstream source, and no local growth is evident: Not checked

Notes about algal cover:

No algal cover.

Algal cover photos and descriptions:

**Differences in vegetation: 0 (Poor) No compositional or density differences in vegetation are present between the banks and the adjacent uplands.**

Notes about differences in vegetation:

No differences in vegetation.

Vegetation differences photos and descriptions:

**Riffle-pool sequence: 0 (Poor) No riffle-pool sequences observed.**

Notes about riffle-pool sequence:

No riffle-pool sequence.

Riffle-pool photos and descriptions:

---

## Supplemental information

Additional notes about the assessment:

Supplemental information photos and descriptions:

---

## Arid West SDAM classification

EPHEMERAL

---

## SDAM resources

---

**End of Report**

SDAM Version 3.0.1 October 2025, Date of site visit: 6-08-19

Page 9 of 9

## **EXHIBIT G. MANUFACTURER'S SPECIFICATIONS**

G

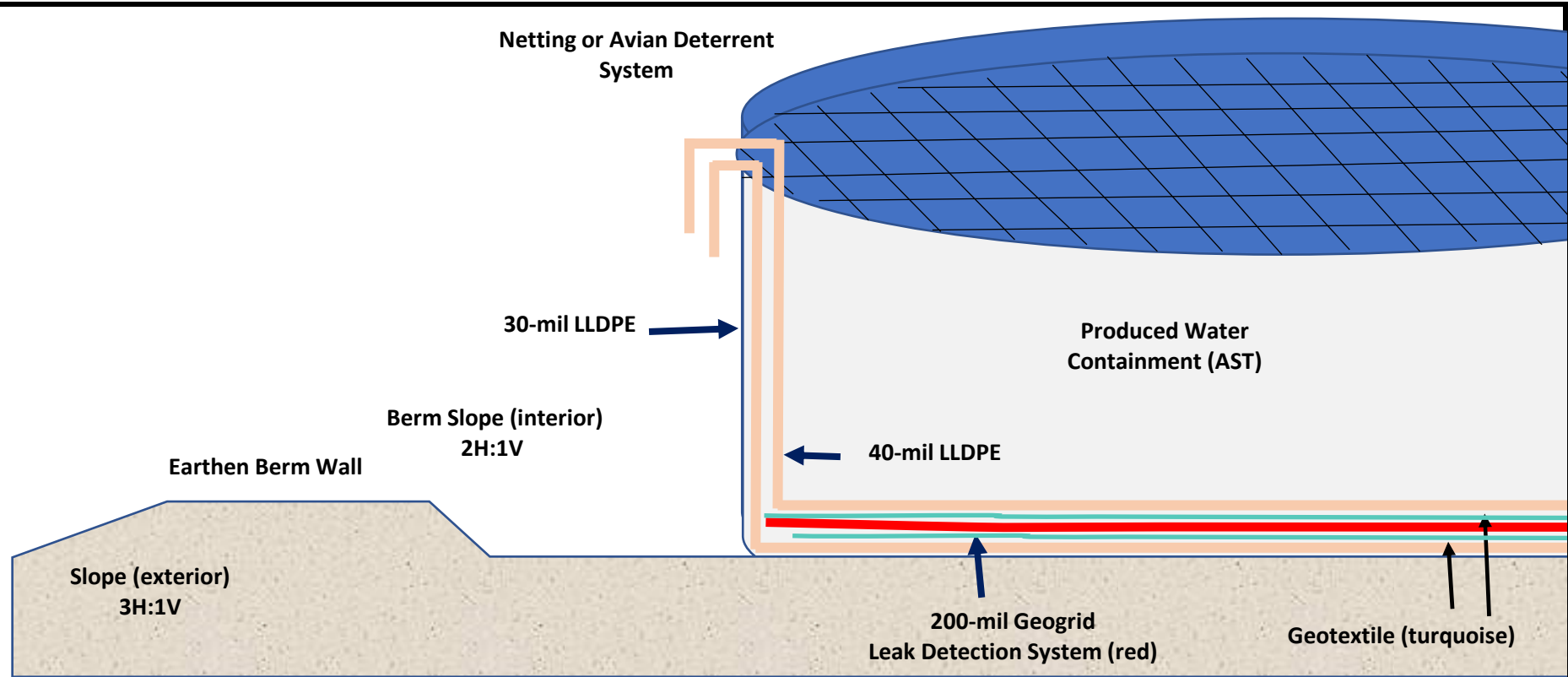

### Description of Leak Detection System

- 40-mil LLDPE comprise primary liner and 30-mil LLDPE comprise the secondary liner
- 200-mil geogrid drainage layer lies between the primary and secondary liner per Plate 2
- Geotextile between the geogrid and each liner
- > 3-inch deep sump excavated on down slope side of AST per Sump Design Drawing
- A small hose runs from the collection sump to top of AST via tube (see Section D)
- Every week, a portable self-priming peristaltic pump connects to the leak detection system.
- The self-priming pump discharge hose runs back into the AST, on top of the primary liner
- If fluid is detected, it is tested for conductance to determine the origin of the water (i.e. produced water or condensation)

R.T. Hicks Consultants Albuquerque, NM	Design Sketch	Plate 1
	Well Water Solutions	May-21

Use laser level to determine slope of pad and low point of AST

200 mil geogrid placed

above 8-oz geotextile and 30-mil secondary liner  
inside of AST after set up, before install of primary liner  
below 40-mil primary liner

8-oz geotextile is placed

over the 30-mil LLDPE liner inside the steel AST ring  
under the 40-mil primary liner inside the AST

Sump at lowest point of the AST set up

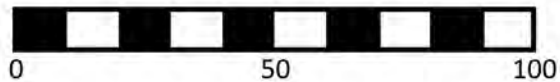
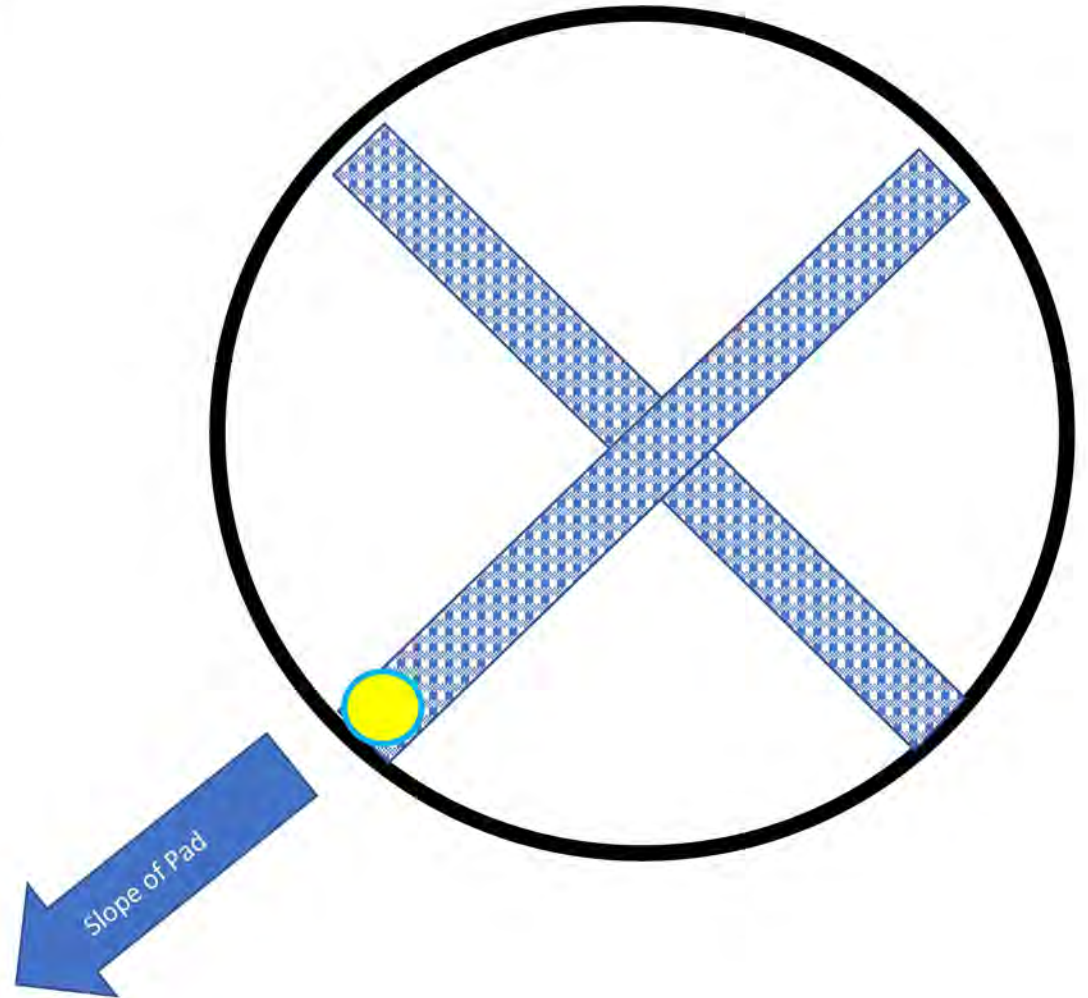

<b>R.T. Hicks Consultants</b> <b>Albuquerque, NM</b>	<b>Layout of Geogrid Drainage Mat</b>	<b>Plate 1</b>
	<b>WWS - New Mexico Produced Water Set Up</b>	<b>June 2021</b>

# WWS DOUBLE-LINED FRAC WATER TANK SYSTEM

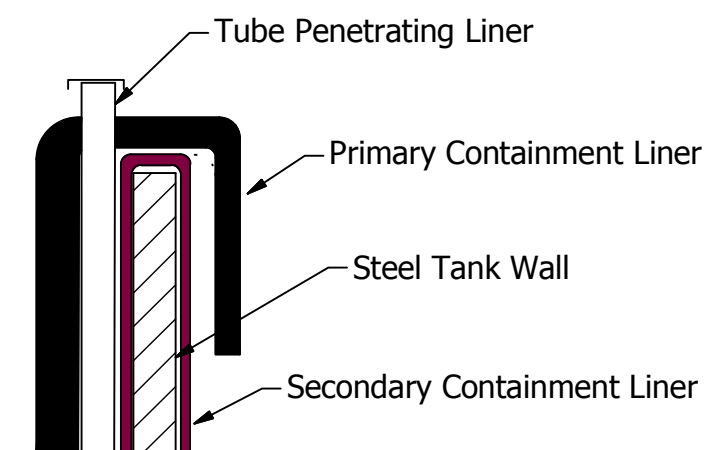
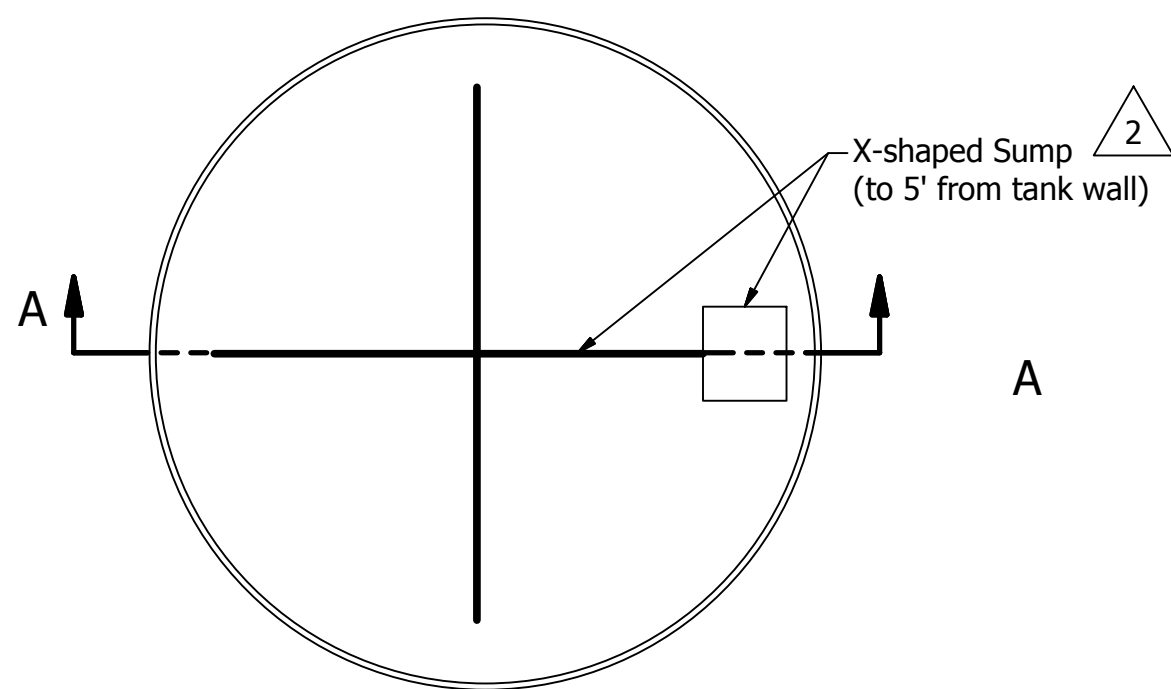

**SECTION D  
TUBE DETAIL**  
(Automated Leak Detection System Removed for Clarity)

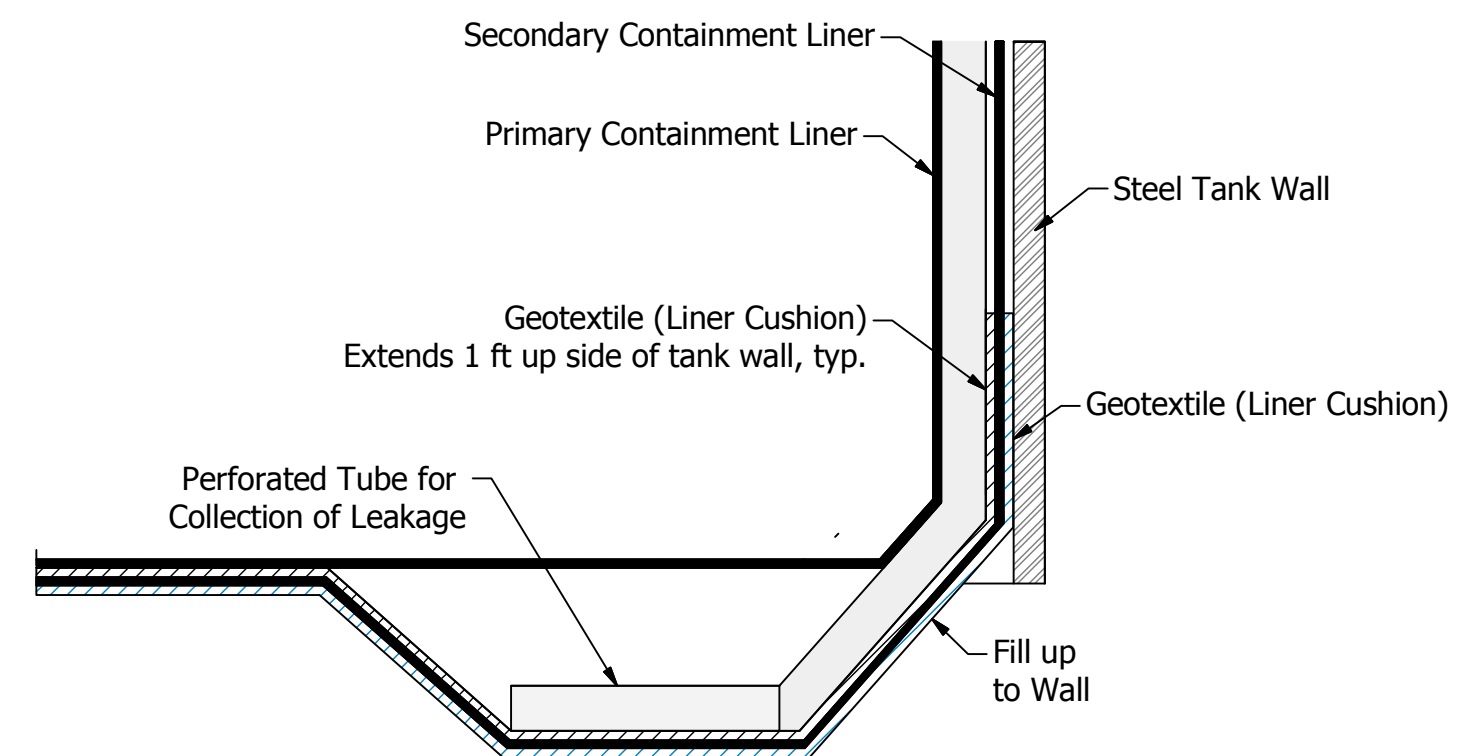
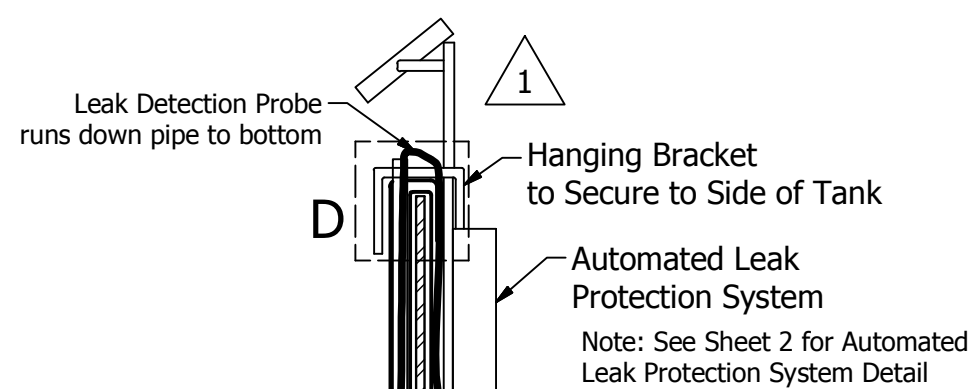

**SECTION B  
SUMP DETAIL**

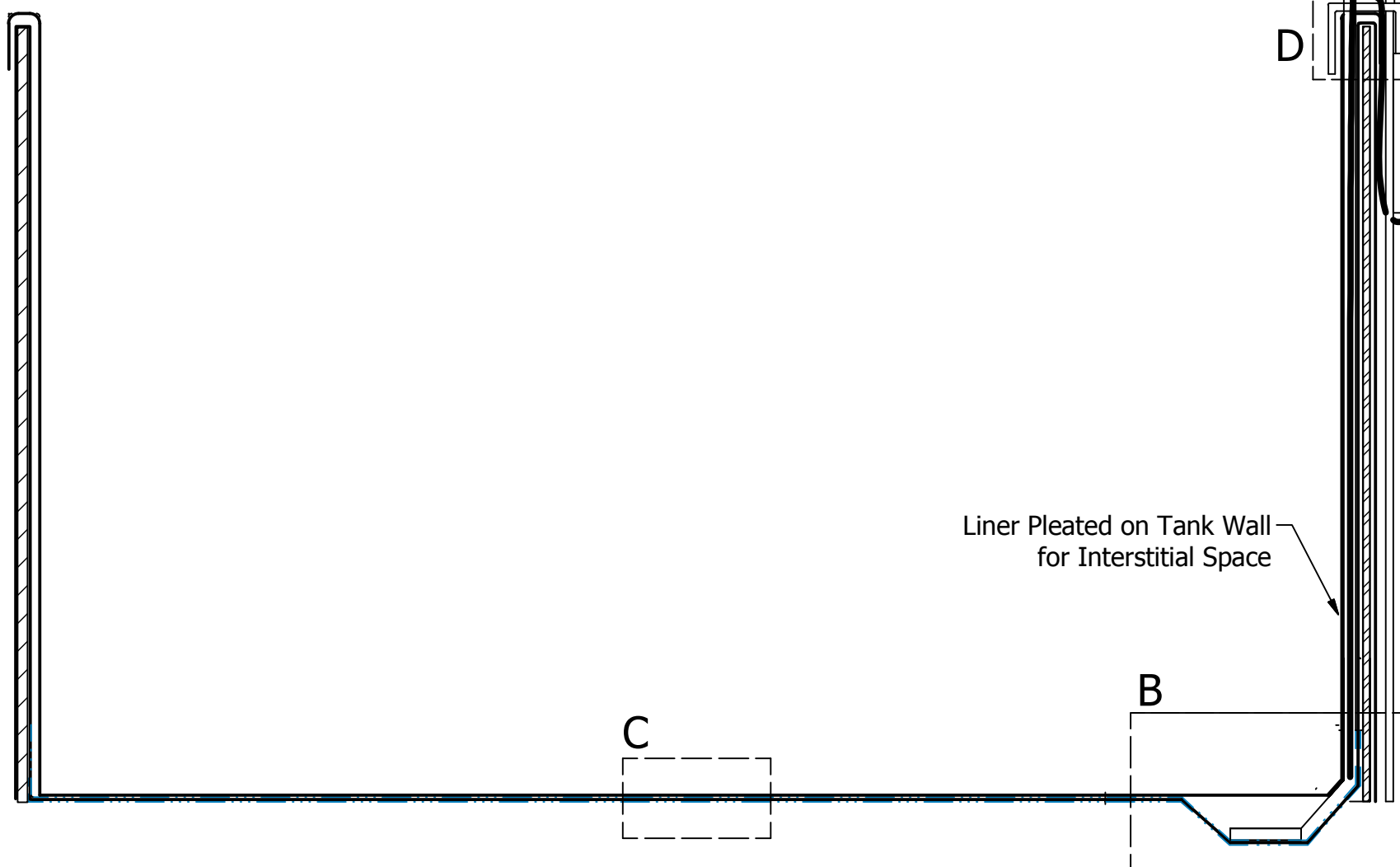

**VIEW A-A  
TANK DETAIL**

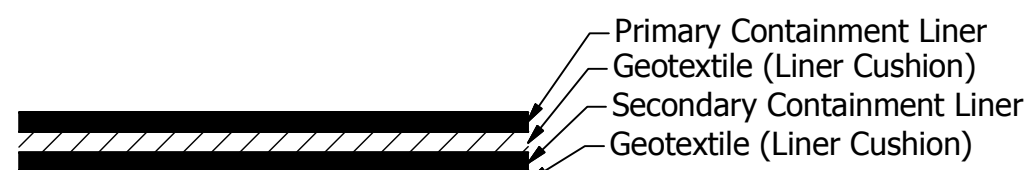

**SECTION C  
LINER DETAIL**

**LUCID**  
DRAFTING & DESIGN LLC  
sarah@luciddrafting.com 307.752.7388

REVISION HISTORY				
REV	DESCRIPTION	DATE	BY	
0	INITIAL DWG	10/29/2015	SES	
1	ADDED LEAK DETECTION SYSTEM	11/6/2015	SES	
2	REVISED SUMP	11/6/2015	SES	
3	ADDED GEOTEXTILE UNDER AND BETWEEN LINERS	11/24/15	SES	

TITLE Double-Lined Frac Tank System	
CUSTOMER	
PROJECT/JOB WWS Double-Lined Tank System	
APPROVAL	
DRAFTER SES	DATE 10/28/2015
THIS DOCUMENT IS THE PROPERTY OF WWS AND MAY NOT BE REPRODUCED OR DISTRIBUTED TO THIRD PARTIES WITHOUT THE PRIOR CONSENT OF WWS.	

**WELL WATER SOLUTIONS**  
AND RENTALS, INC.

SIZE C	DWG NO LDD15-WWS-02	REV 3
SHEET 1 OF 2		

### 1 AUTOMATED LEAK DETECTION SYSTEM

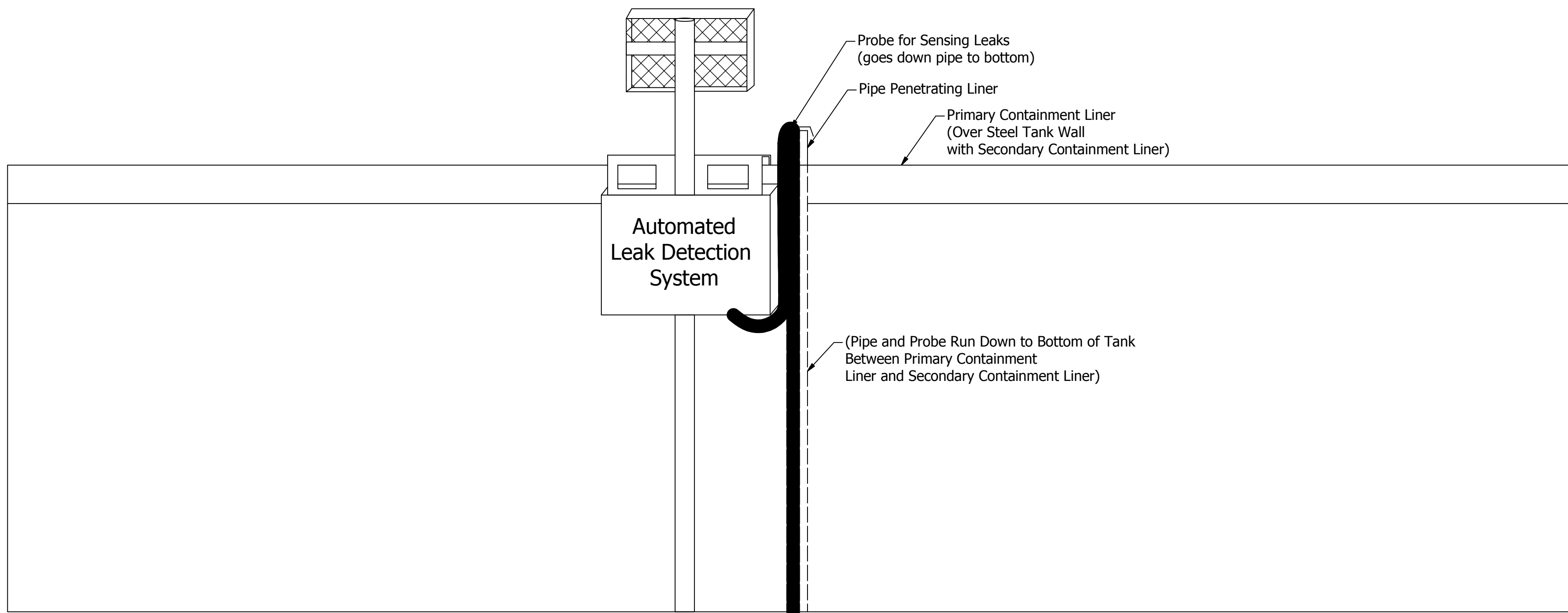

TITLE				
Double-Lined Frac Tank System				
CUSTOMER				
PROJECT/JOB WWS Double-Lined Tank System				
APPROVAL		SIZE	DWG NO	REV
DRAFTER SES	DATE 10/28/2015	C	LDD15-WWS-02	3
THIS DOCUMENT IS THE PROPERTY OF WWS AND MAY NOT BE REPRODUCED OR DISTRIBUTED TO THIRD PARTIES WITHOUT THE PRIOR CONSENT OF WWS.		SHEET 2 OF 2		

CK	ITEM	QTY	DESCRIPTION	WIDTH	LENGTH	MATERIAL	LENGTH (in)	WEIGHT
1	14		BAR, ROUND, 5/8" (LOCK PIN)		6 1/2 in	A36	6.50	
2	2		D-RING, 1/2" B38, WORKING LOAD 4000 lbs			A29/A29M - S1 1045(C-1045), MODIFIED TO WELD DOWN		2
3	2		FBAR, 1"	10 in	124 1/2 in	A36	121.50	373
4	2		FBAR, 10GA	3 in	43 1/8 in	A36	86.25	99
5	2		PAD EYE, #2			CROSBY GROUP, S-264		0
6	7		PM, 2" DIA		4 1/2 in	KUSTOM KONCEPTS, M010	31.50	3
7	7		PM, 3" DIA		4 1/2 in	KUSTOM KONCEPTS, M010	31.50	8
8	2		PLATE, 3/16"	3 in	5 in	A36	10.00	2
9	1		PLATE, 3/16"	96 in	240 in	A36	240.00	156
10	6		SHEET, 10GA	2 1/2 in	3 3/4 in	A36	22.50	3
11	1		SHEET, 10GA	42 1/2 in	240 in	A36	240.00	50
12	2		TUBE, 4" x 2" x 1/4" (MITER BOTH ENDS)		52 in	A500B CLEAN COAT	104.00	55
13	3		TUBE, 4" x 2" x 3/16"		37 1/4 in	A500B CLEAN COAT	74.50	43
14	3		TUBE, 4" x 2" x 3/16"		42 3/4 in	A500B CLEAN COAT	128.25	74
15	2		TUBE, 4" x 2" x 3/16"		44 in	A500B CLEAN COAT	88.00	50
16	2		TUBE, 4" x 2" x 3/16"		132 in	A500B CLEAN COAT	264.00	151
17	1		TUBE, 4" x 2" x 3/16" (MITER BOTH ENDS)		137 1/2 in	A500B CLEAN COAT	137.50	78
18	2		TUBE, 4" x 2" x 3/16", (ROLL TO 155'-6 7/8" LD.)		236 3/8 in	A500B CLEAN COAT	472.75	271
19	2		TUBE, 4" x 2" x 3/16", (ROLL TO 155'-6 7/8" LD.)		253 7/8 in	A500B CLEAN COAT	507.75	291

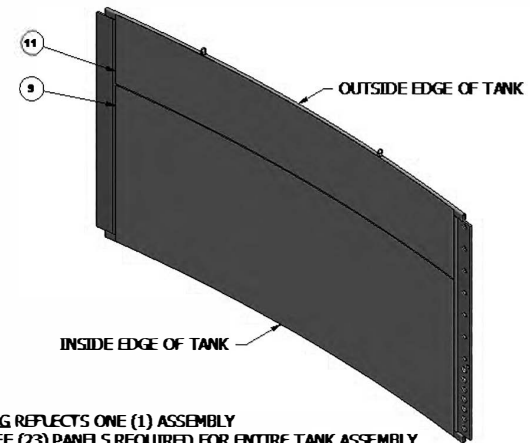
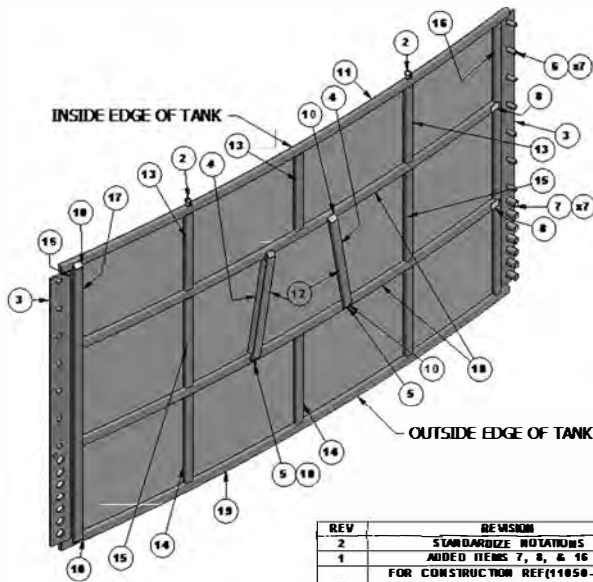

**NOTES:**  
 -THIS DRAWING REFLECTS ONE (1) ASSEMBLY  
 -TWENTY THREE (23) PANELS REQUIRED FOR ENTIRE TANK ASSEMBLY

REV	REVISION	DATE	BY
2	STANDARDIZE NOTATIONS	11/17/2012	JDV
1	ADDED ITEMS 7, 8, & 16	12/09/11	DSG
0	FOR CONSTRUCTION REF(1050-901) CHANGED HEIGHT AND LOCATION OF PMS REF(1078-40-901)	3/1/2011	CJD

<p>A NALCO COMPANY</p> <p>4500 33 1/2 Rd Casper, WY 82601 (307)472-9740</p>	Unless otherwise stated SHARP CORNERS SHALL BE 1/8" RADIUS FOR NON-GLAZED SURFACES. APPROVED:	Title: N/A Job Group: T - TANKS COUNTRY OF ORIGIN: U.S.A. Proposed Job #: WELL WATER SOLUTIONS	This drawing contains confidential information and is intended for internal use only. It is the property of FabTech. It is not to be distributed outside of the company without the express written consent of FabTech. Any disclosure to the public is prohibited.
	Original Designer: JDV Date: 5/31/2011 Original From:	Scale: 1 of 5 Drawing Number: WR-40-901 Rev: 2	Project Job #: WELL WATER SOLUTIONS TANK PANEL

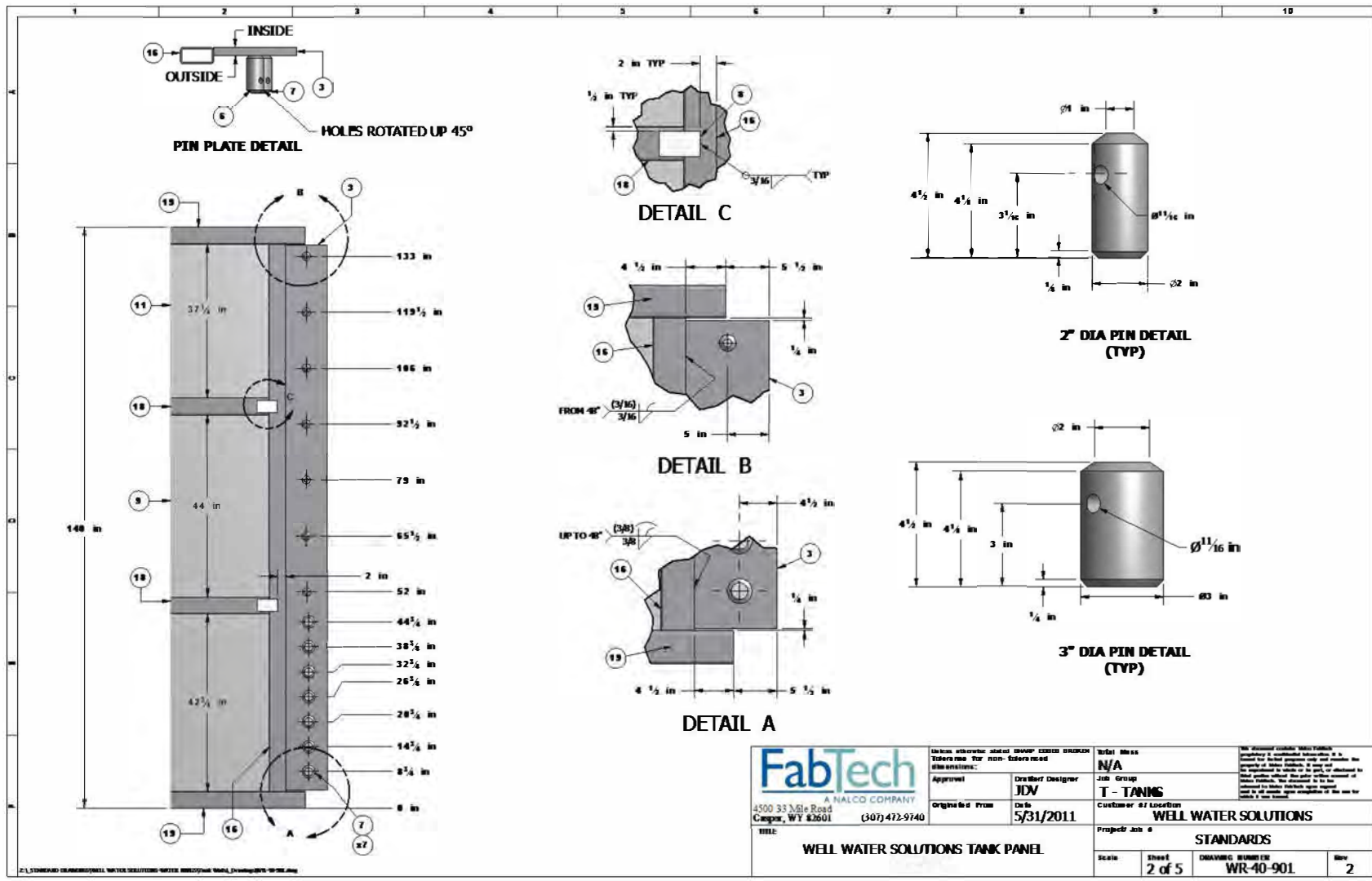

<b>FabTech</b> A NALCO COMPANY 4500 33 Mile Road Casper, WY 82601 (307) 472-9740	Issues: whenever you or group leader discuss drawings for these drawings	Title: <b>WELL WATER SOLUTIONS TANK PANEL</b>	Total Mass: <b>N/A</b>	The customer hereby warrants that the drawings are complete and correct as presented and that the customer is not responsible for any errors or omissions in the drawings. The drawings are to be used for the construction of the tank and are not to be used for any other purpose without the written consent of the manufacturer.
	Approval: _____ Originals From: _____	Draftsman/Designer: <b>JDV</b> Date: <b>5/31/2011</b>	Customer #7 Location: <b>WELL WATER SOLUTIONS</b>	Job Group: <b>T - TANKS</b>
Project Job #: _____		Project Job #: _____		
Scale: _____		Drawing Number: <b>WR-40-901</b>		
Sheet: <b>2 of 5</b>		Rev: <b>2</b>		





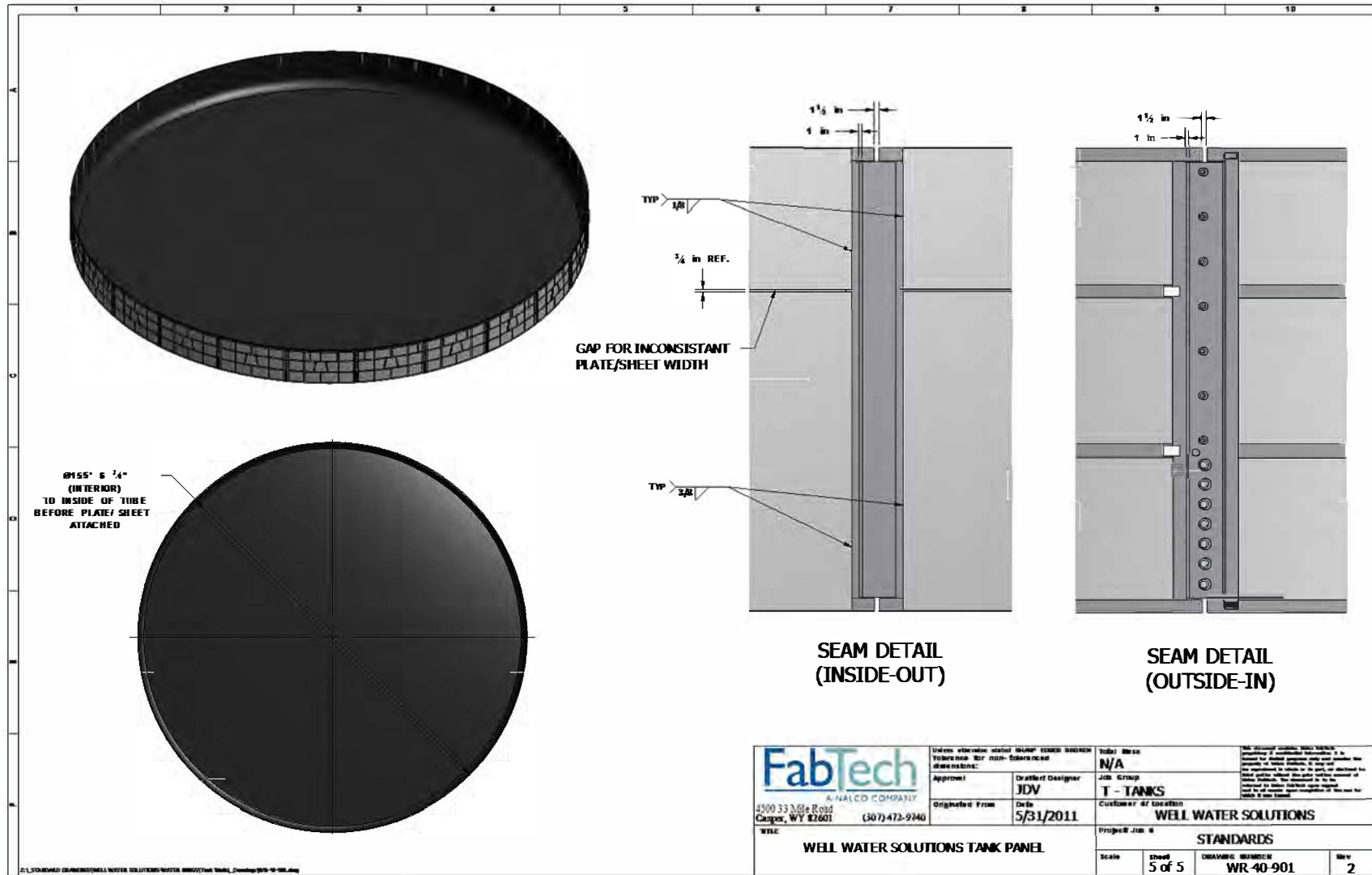

<b>FabTech</b> <small>A NALCO COMPANY</small> 4500 13 Mile Road Casper, WY 82601 (307) 472-9240	Unless otherwise stated, ALL DIMENSIONS SHALL BE IN INCHES UNLESS OTHERWISE SPECIFIED.	Title Block N/A	ALL DIMENSIONS UNLESS OTHERWISE SPECIFIED ARE IN INCHES. DIMENSIONS IN PARENTHESES ARE TO BE USED FOR FABRICATION. DIMENSIONS IN PARENTHESES ARE TO BE USED FOR FABRICATION. DIMENSIONS IN PARENTHESES ARE TO BE USED FOR FABRICATION. DIMENSIONS IN PARENTHESES ARE TO BE USED FOR FABRICATION.
	Approved:	Drafted/Designer JDV	
Originated From	Date 5/31/2011	Customer #/ Location WELL WATER SOLUTIONS	
WELC WELL WATER SOLUTIONS TANK PANEL		Project Job # STANDARDS	
Scale	Sheet 5 of 5	DRAWING NUMBER WR-40-901	Rev 2



# TANK SIZE CHART

TANK SIZE BBLs	PANEL COUNT	INSIDE DIAMETER (FEET)	VOLUME BBLs	BBLs/INCH	SECONDARY CONTAINMENT (ADD 2 PANELS)	SECONDARY CONTAINMENT DIAMETER	TOTAL FEET OF CONTAINMENT
6,000	9	60' 2"	6,090	43.5	11	75'	234'
10,000	12	81' 2"	10,753	76.8	14	95'	298'
13,000	13	87' 10-5/8"	12,609	90.1	15	101'	318'
17,000	15	101.4285	16,800	120	17	115'	361'
20,000	16	108' 2"	19,115	136.53	18	122'	384'
22,000	17	114' 11-7/16"	21,564	154.03	19	135'	426'
27,000	19	128' 6-1/4"	26,954	192.53	21	142'	446"
30,000	20	135' 3-3/8"	29,867	213.35	22	149'	468'
33,000	21	142' 0-9/16"	32,928	235.2	23	156'	489'
36,000	22	148' 9-11/16"	36,139	258.14	24	163'	510'
40,000	23	155' 6-7/8"	39,499	282.14	25	170'	532'
43,000	24	162' 4-1/16"	43,008	307.2	26	176'	553'
47,000	25	169' 1-3/16"	46,667	333.34	27	183'	574'
50,000	26	175' 10-5/16"	50,475	360.54	28	190'	595'
55,000	27	182' 7-9/16"	54,433	388.8	29	196'	617'
60,000	28	189' 4-11/16"	58,539	418.14	30	203'	638'
62,500	29	196' 1/16"	62,500	446.43	31	210'	658'
67,000	30	202' 10 6/16"	66,885	477.75	32	216'	678'
72,000	31	209' 7-7/16"	71,705	512.18	33	223'	701'
77,000	32	216' 4-9/16"	76,405	545.75	34	230'	722'
81,000	33	223' 1-11/16"	81,254	580.39	35	237'	744'

## **EXHIBIT H. VARIANCE REQUESTS**

H

**ENDURING RESOURCES IV LLC**

6300 S Syracuse Way Centennial, CO 80111  
Field Office: 505.636.9720 | Main Office: 303.573.1222

**Enduring Resources IV, LLC North Alamito Unit A19/N17 AST Pad Recycling Containment and Recycling Facility Variance Request to 19.15.34 NMAC**

New Mexico Oil Conservation Division  
Attn: Victoria Venegas

Enduring Resources is requesting variances to the below listed items as outlined in 19.15.34 NMAC. This Recycling Containment/Facility will consist of a self-contained free-standing structure instead of a lined earthen pit. The variances requested below will provide equal or better protection of fresh water, public health, and the environment.

**Variance Requests:**

**Inside/Outside Levee Slopes:** Enduring Resources requests a variance to NMAC 19.15.34.12 (A)(2) which applies to a lined earthen pit. The containment is an AST not an in-ground pond; therefore, will not have inside/outside levee slopes. The AST is a self-contained free-standing structure that will provide equal or better protection than the requirements listed in 19.15.34.12 (A)(2) NMAC.

**Liner Anchoring:** Enduring Resources requests a variance to NMAC 19.15.34.12 (A)(3) which applies to a lined earthen pit. This statute is not applicable to a circular steel AST with liners clamped to the top of the steel containment panels. We believe this will provide equal or better protection than the requirements listed in 19.15.34.12 (A)(3) NMAC.

**Primary Liner:** Enduring Resources requests a variance to NMAC 19.15.34.12 (A)(4) which applies to the thickness of the primary liner. Enduring Resources proposes the use of a 40-mil LLDPE primary liner and 30-mil LLDPE secondary liner. The proposed variance will provide equal or better protection of fresh water, public health and the environment, as the proposed liner meets all other requirements of NMAC 19.15.34.12 (A)(4) and meets or exceeds the EPA SW-846 method 9090A or subsequent relevant publication.

**Fencing:** Enduring Resources requests a variance to NMAC 19.15.34.12 (D)(1) and (2) which applies to fencing or enclosing the containment. With the recycling containment being an AST with 12-foot wall height, entrance to containment would have to be intentional. There is no risk of accidental entrance into containment by wildlife or the public. The site will be maintained to prevent harm to wildlife and the public. The freestanding above grade AST will provide equal or better protection to public health and the environment, as the fencing requirements of NMAC 19.15.34.12 (D)(1) and (2).

Thank you,

Casey Haga  
Regulatory Specialist  
Enduring Resources, LLC.  
970.769.8814 – Cell

**Venegas, Victoria, EMNRD**

---

**From:** Venegas, Victoria, EMNRD  
**Sent:** Friday, March 20, 2026 1:42 PM  
**To:** Heather Huntington; Casey Haga; osheldon@barr.com  
**Subject:** FVV2607936716 NORTH ALAMITO UNIT A19/N17 AST PAD  
**Attachments:** C-147 FVV2607936716 NORTH ALAMITO UNIT A19N17 AST PAD 03.20.2026.pdf

**FVV2607936716 NORTH ALAMITO UNIT A19/N17 AST PAD**

Good afternoon Ms. Huntington.

**NOTE:** On page 31, the application states that the term ‘significant,’ when referring to a watercourse, is not defined in NMAC. However, the term *Significant Watercourse* is defined in 19.15.17 NMAC: Pits, Closed-Loop Systems, Below-Grade Tanks, and Sumps:

- **19.15.17.7.P: “Significant watercourse”** means a watercourse with a defined bed and bank either named or identified by a dashed blue line on a USGS 7.5-minute quadrangle map or the next lower order tributary with a defined bed and bank of such watercourse.”

NMOCD has reviewed the recycling containment permit application and related documents, submitted by [371838] DJR OPERATING, LLC on 03/03/2026, Application ID **559424**, for FVV2607936716 NORTH ALAMITO UNIT A19/N17 AST PAD in E-20-23N-07W, Sandoval County, New Mexico. [371838] DJR OPERATING, LLC requested variances from 19.15.34 NMAC for FVV2607936716 NORTH ALAMITO UNIT A19/N17 AST PAD.

The following variances have been approved:

- The variance to 19.15.34.12.A.(2) NMAC for the no side-slope requirement for the AST containment with vertical walls is approved.
- The variance to 19.15.34.12.A.(3) NMAC for the liners to be anchored to the top of the AST steel walls and no anchor trenches is approved.
- The variance to 19.15.34.12.A.(4) NMAC for the installation on the AST containment of a 40-mil LLDPE primary liner and a 30-mil LLPDE secondary liner is approved.
- [371838] DJR OPERATING, LLC requests a variance to NMAC 19.15.34.12 (D)(l) and (2) which applies to fencing or enclosing the containment. The freestanding 12-foot wall height above grade ASTs will provide equal or better protection to public health and the environment, as the fencing requirements of NMAC 19.15.34.12 (D)(l) and (2). This variance is approved.

The form C-147 and related documents for FVV2607936716 NORTH ALAMITO UNIT A19/N17 AST PAD are approved with the following conditions of approval:

- **19.15.34.3 STATUTORY AUTHORITY:** 19.15.34 NMAC is adopted pursuant to the Oil and Gas Act, Paragraph (15) of Subsection B of Section 70-2-12 NMSA 1978, which authorizes the division to regulate the disposition, handling, transport, storage, recycling, treatment and disposal of produced water during, or for re-use in, the exploration, drilling, production, treatment or refinement of oil or gas in a manner that protects public health, the environment and fresh water resources and Paragraph (21) of Subsection B of Section 70-2-12 NMSA 1978 which authorizes the regulation of the disposition of nondomestic wastes from the exploration, development, production or storage of crude oil or natural gas. [19.15.34.3 NMAC - Rp, 19.15.34.3 NMAC, 3/31/2015; A, 10/13/2020]
- FVV2607936716 NORTH ALAMITO UNIT A19/N17 AST PAD is approved for five years of operation from the date of permit application of 03/03/2026. FVV2607936716 NORTH ALAMITO UNIT A19/N17 AST PAD permit

expires on 03/03/2031. If [371838] DJR OPERATING, LLC wishes to extend operations past five years, an annual permit extension request must be submitted using an OCD form C-147 through OCD Permitting by 01/03/2031.

- FVV2607936716 NORTH ALAMITO UNIT A19/N17 AST PAD will consist of one above ground storage tank (AST) of 43,000 barrels of capacity. The AST containment will be surrounded by an Earthen Berm Wall as shown in Exhibit G Plate 1.
- The recycling facility will consist of up to (30) 400 bbl vertical frac tanks with a consolidated volume of 12,000 barrels to treat (mechanical and chemical reconditioning process) produced water for reuse.
- [371838] DJR OPERATING, LLC must submit a recycling facility modification in the event the number of frac tanks exceeds the approved number of thirty (30) 400 bbl vertical frac tanks.
- Water reused and recycled from FVV2607936716 NORTH ALAMITO UNIT A19/N17 AST PAD is limited to wells owned or operated by [371838] DJR OPERATING, LLC per 19.15.34.15(A)(2) NMAC.
- [371838] DJR OPERATING, LLC shall construct, operate, maintain, close, and reclaim FVV2607936716 NORTH ALAMITO UNIT A19/N17 AST PAD in compliance with NMAC 19.15.34 NMAC.
- [371838] DJR OPERATING, LLC shall notify OCD, through OCD Permitting when construction of FVV2607936716 NORTH ALAMITO UNIT A19/N17 AST PAD commences.
- [371838] DJR OPERATING, LLC shall notify NMOCD through OCD Permitting when recycling operations commence and cease at FVV2607936716 NORTH ALAMITO UNIT A19/N17 AST PAD.
- A minimum 3-foot freeboard must be maintained at FVV2607936716 NORTH ALAMITO UNIT A19/N17 AST PAD at all times during operations.
- If less than 20% of the total fluid capacity is utilized every six months, beginning from the first withdrawal, operations of the FVV2607936716 NORTH ALAMITO UNIT A19/N17 AST PAD are considered ceased and a notification of cessation of operations should be sent electronically to OCD Permitting. A request to extend the operations, not to exceed six months, may be submitted using a C-147 form to OCD Permitting. If after the 6-month extension period, the FVV2607936716 NORTH ALAMITO UNIT A19/N17 AST PAD is not utilized at a minimum of 20% fluid capacity, no additional extensions would be granted, and the operator would be directed to remove all fluids and proceed with the closure requirements.
- [371838] DJR OPERATING, LLC shall submit monthly reports of recycling and reuse of produced water, drilling fluids, and liquid oil field waste to OCD Permitting even if there is zero activity.
- [371838] DJR OPERATING, LLC shall inspect the recycling containments and associated leak detection systems weekly while it contains fluids. The operator shall maintain a current log of such inspections and make the log available for review by the division upon request according to 19.15.34.13.A.
- [371838] DJR OPERATING, LLC shall comply with 19.15.29 NMAC Releases in the event of any release of produced water or other oil field waste at FVV2607936716 NORTH ALAMITO UNIT A19/N17 AST PAD.
- According to Table 1 of NMAC 19.15.34.14, the closure criteria for FVV2607936716 NORTH ALAMITO UNIT A19/N17 AST PAD is for groundwater depth of 51 to 100 feet.

Please let me know if you have any additional questions.  
Best regards,

**Victoria Venegas** • Senior Environmental Scientist  
EMNRD - Oil Conservation Division  
506 W. Texas Ave. Artesia, NM 88210  
575.909.0269 | [Victoria.Venegas@emnrd.nm.gov](mailto:Victoria.Venegas@emnrd.nm.gov)

Sante Fe Main Office  
Phone: (505) 476-3441

General Information  
Phone: (505) 629-6116

Online Phone Directory  
<https://www.emnrd.nm.gov/ocd/contact-us>

**State of New Mexico**  
**Energy, Minerals and Natural Resources**  
**Oil Conservation Division**  
**1220 S. St Francis Dr.**  
**Santa Fe, NM 87505**

CONDITIONS

Action 559424

**CONDITIONS**

Operator: DJR OPERATING, LLC 200 Energy Court Farmington, NM 87401	OGRID: 371838
	Action Number: 559424
	Action Type: [C-147] Water Recycle Long (C-147L)

**CONDITIONS**

Created By	Condition	Condition Date
vvenegas	FVV2607936716 NORTH ALAMITO UNIT A19/N17 AST PAD permit expires on 03/03/2031. If [371838] DJR OPERATING, LLC wishes to extend operations past five years, an annual permit extension request must be submitted using an OCD form C-147 through OCD Permitting by 01/03/2031. • [371838] DJR OPERATING, LLC shall construct, operate, maintain, close, and reclaim FVV2607936716 NORTH ALAMITO UNIT A19/N17 AST PAD in compliance with NMAC 19.15.34 NMAC. • [371838] DJR OPERATING, LLC shall comply with 19.15.29 NMAC Releases in the event of any release of produced water or other oil field waste at FVV2607936716 NORTH ALAMITO UNIT A19/N17 AST PAD.	3/20/2026