

Office
District I - (575) 393-6161
1625 N. French Dr., Hobbs, NM 88240
District II - (575) 748-1283
811 S. First St., Artesia, NM 88210
District III - (505) 334-6178
1000 Rio Brazos Rd., Aztec, NM 87410
District IV - (505) 476-3460
1220 S. St. Francis Dr., Santa Fe, NM 87505

State of New Mexico
Energy, Minerals and Natural Resources

Form C-103
Revised July 18, 2013

OIL CONSERVATION DIVISION
1220 South St. Francis Dr.
Santa Fe, NM 87505

WELL API NO. 30-025-29275
5. Indicate Type of Lease STATE [x] FEE []
6. State Oil & Gas Lease No. 19520
7. Lease Name or Unit Agreement Name North Hobbs G/SA Unit
8. Well Number 234
9. OGRID Number 157984
10. Pool name or Wildcat HOBBS; GRAYBURG-SAN ANDRES
11. Elevation (Show whether DR, RKB, RT, GR, etc.) 3363' (KB)

SUNDRY NOTICES AND REPORTS ON WELLS
(DO NOT USE THIS FORM FOR PROPOSALS TO DRILL OR TO DEEPEN OR PLUG BACK TO A DIFFERENT RESERVOIR. USE "APPLICATION FOR PERMIT" (FORM C-101) FOR SUCH PROPOSALS.)
1. Type of Well: Oil Well [x] Gas Well [] Other []
2. Name of Operator Occidental Permian LTD
3. Address of Operator P.O. Box 4294 Houston, TX 77210-4294
4. Well Location
Unit Letter K : 1372 feet from the SOUTH line and 2563 feet from the WEST line
Section 33 Township 18S Range 38E NMPM County LEA

12. Check Appropriate Box to Indicate Nature of Notice, Report or Other Data

NOTICE OF INTENTION TO:
PERFORM REMEDIAL WORK [] PLUG AND ABANDON []
TEMPORARILY ABANDON [] CHANGE PLANS []
PULL OR ALTER CASING [] MULTIPLE COMPL []
DOWNHOLE COMMINGLE []
CLOSED-LOOP SYSTEM []
OTHER: CTI & Liner [x]
SUBSEQUENT REPORT OF:
REMEDIAL WORK [] ALTERING CASING []
COMMENCE DRILLING OPNS. [] P AND A []
CASING/CEMENT JOB []
OTHER: []

13. Describe proposed or completed operations. (Clearly state all pertinent details, and give pertinent dates, including estimated date of starting any proposed work). SEE RULE 19.15.7.14 NMAC. For Multiple Completions: Attach wellbore diagram of proposed completion or recompletion.

See planned procedure attached.

Condition of Approval: notify
OCD Hobbs office 24 hours
prior of running MIT Test & Chart

Spud Date: []

Rig Release Date: []

I hereby certify that the information above is true and complete to the best of my knowledge and belief.

SIGNATURE Roni Mathew TITLE Regulatory Advisor DATE 09/16/2022

Type or print name Roni Mathew E-mail address: roni_mathew@oxy.com PHONE: (713) 215-7827

For State Use Only

APPROVED BY: Kerry Fortner TITLE Compliance Officer A DATE 9/21/22

Conditions of Approval (if any):

NHU 33-234

API #: 30-025-29275

Objective: Convert well from production to WAG injection. Run partial liner to ensure injection is only entering targeted zones.

Procedure:

1. MIRU PU
2. Kill well x ND WH x NU BOP
3. POOH with ESP Eqpt
4. RIH with cement retainer on 2-7/8" WS & set at ~4000'
5. Cement squeeze existing perforations. Sting out retainer & POOH with workstring.
6. PU 6-1/4" bit + drill collars
7. Drill out CICR & cement to PBTD at 4327'. Pressure test squeeze.
8. RIH with 5.5" FJ partial liner. Land liner from ~3700'-4325'. Cement liner in place.
9. RIH w/ 6-1/4" bit & DO to top of liner. POOH with 6-1/4" bit. RIH with 4-3/4" bit and CO to new PBTD. POOH with bit.
10. RU WL
11. Run CBL x Log both 5-1/2" & 7.0" casings
12. Perforate liner from ~4050'-~4200'.
13. RD WL. RIH with RBP & packer.
14. Acid stimulate new perfs with ~5000 gals of 15% HCL NEFE
15. POOH with RBP & packer.
16. RIH with injection equipment.
17. RD PU
18. Return well to injection.

Current WBD

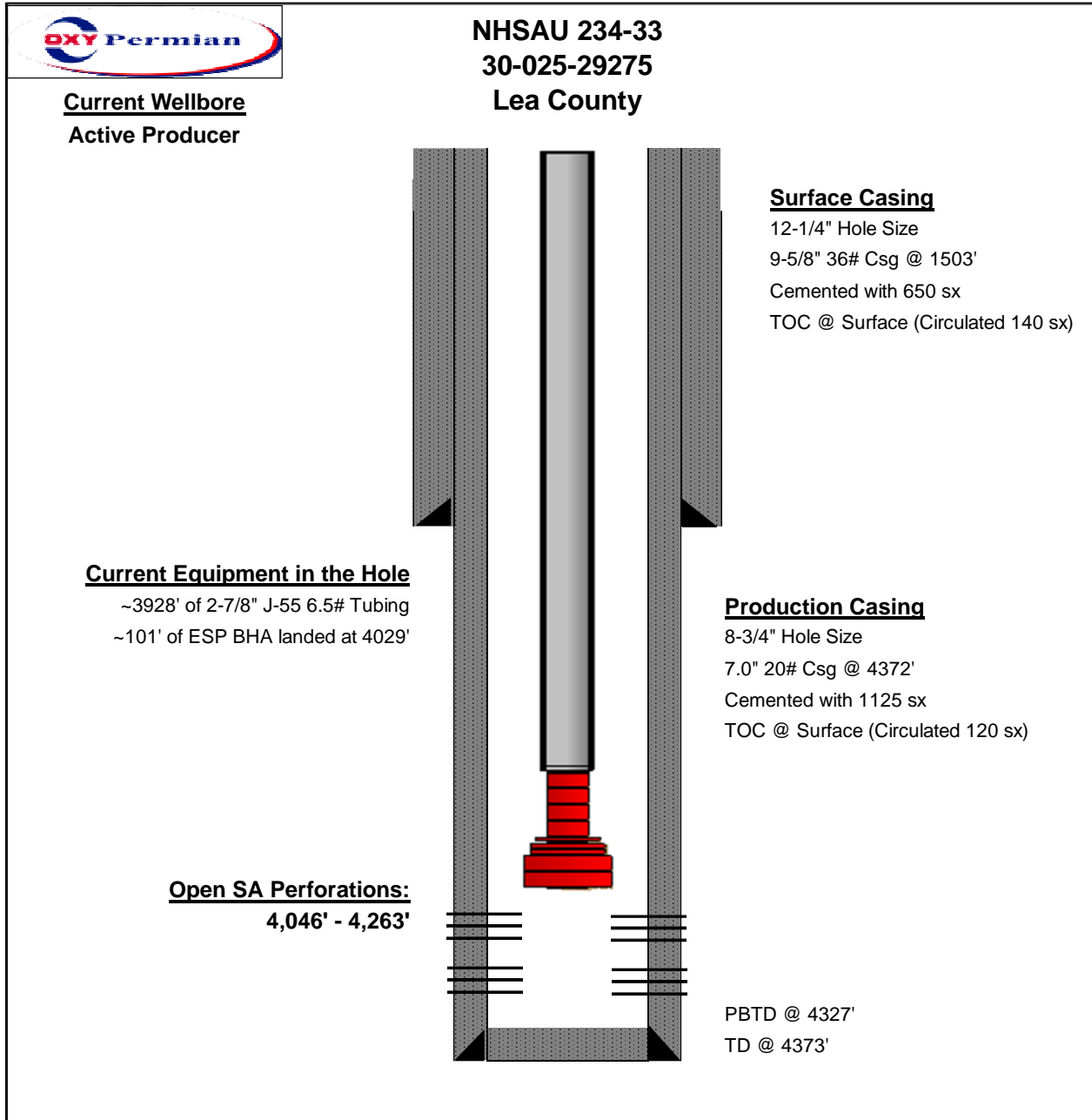

Proposed WBD

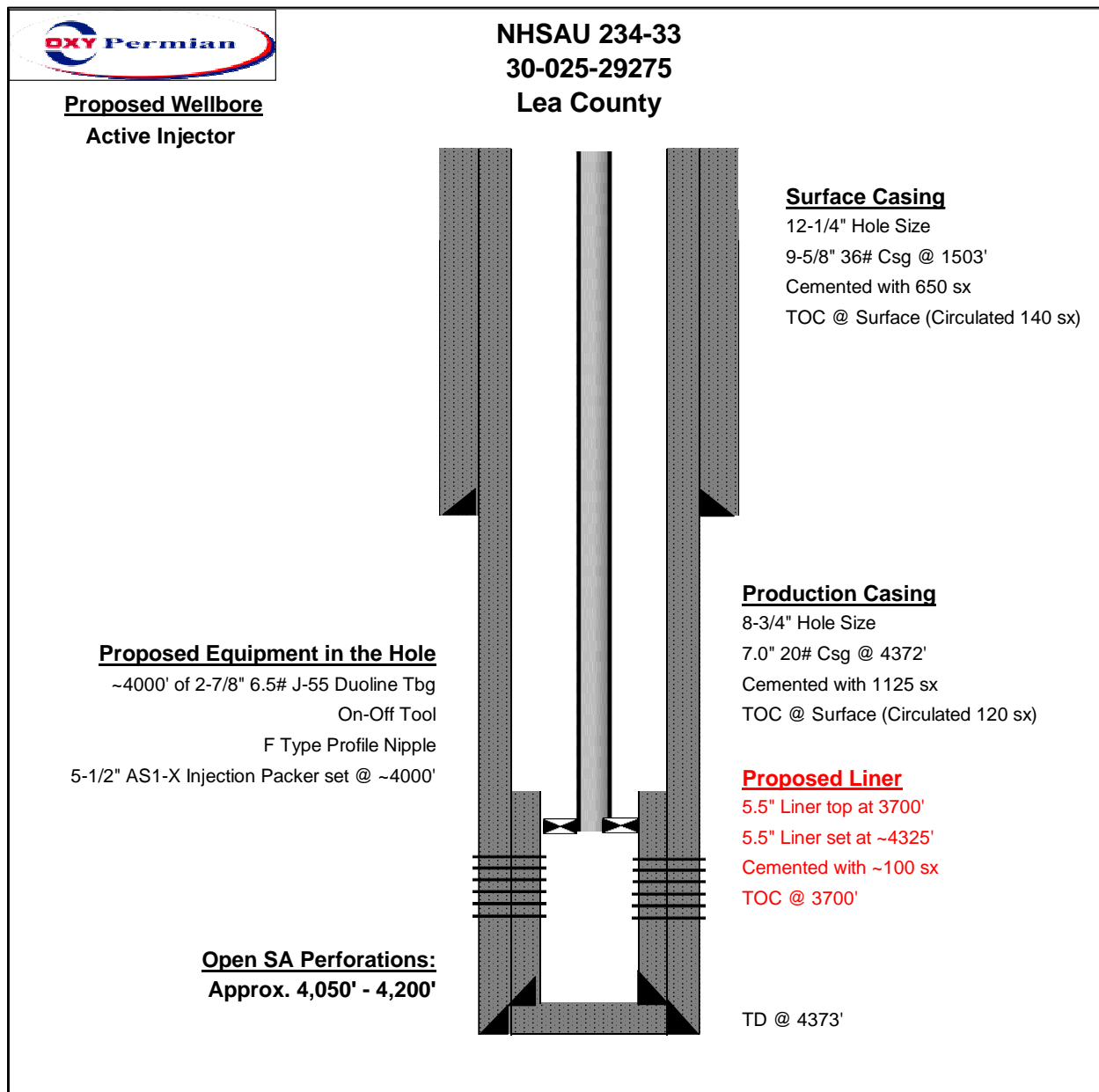

District I
 1625 N. French Dr., Hobbs, NM 88240
 Phone:(575) 393-6161 Fax:(575) 393-0720

District II
 811 S. First St., Artesia, NM 88210
 Phone:(575) 748-1283 Fax:(575) 748-9720

District III
 1000 Rio Brazos Rd., Aztec, NM 87410
 Phone:(505) 334-6178 Fax:(505) 334-6170

District IV
 1220 S. St Francis Dr., Santa Fe, NM 87505
 Phone:(505) 476-3470 Fax:(505) 476-3462

State of New Mexico
Energy, Minerals and Natural Resources
Oil Conservation Division
1220 S. St Francis Dr.
Santa Fe, NM 87505

CONDITIONS

Action 144151

CONDITIONS

Operator: OCCIDENTAL PERMIAN LTD P.O. Box 4294 Houston, TX 772104294	OGRID: 157984
	Action Number: 144151
	Action Type: [C-103] NOI Workover (C-103G)

CONDITIONS

Created By	Condition	Condition Date
kfortner	Run PWOT	9/21/2022