

Submit a Copy To Appropriate District Office
District I - (575) 393-6161
1625 N. French Dr., Hobbs, NM 88240
District II - (575) 748-1283
811 S. First St., Artesia, NM 88210
District III - (505) 334-6178
1000 Rio Brazos Rd., Aztec, NM 87410
District IV - (505) 476-3460
1220 S. St. Francis Dr., Santa Fe, NM 87505

State of New Mexico
Energy, Minerals and Natural Resources

Form C-103
Revised July 18, 2013

OIL CONSERVATION DIVISION
1220 South St. Francis Dr.
Santa Fe, NM 87505

WELL API NO. 30-025-29622
5. Indicate Type of Lease STATE [X] FEE [ ]
6. State Oil & Gas Lease No.
7. Lease Name or Unit Agreement Name Eunice Monument South Unit
8. Well Number 462
9. OGRID Number 330679
10. Pool name or Wildcat Eunice Monument; Grayburg-San Andres
11. Elevation (Show whether DR, RKB, RT, GR, etc.)

SUNDRY NOTICES AND REPORTS ON WELLS
(DO NOT USE THIS FORM FOR PROPOSALS TO DRILL OR TO DEEPEN OR PLUG BACK TO A DIFFERENT RESERVOIR. USE "APPLICATION FOR PERMIT" (FORM C-101) FOR SUCH PROPOSALS.)
1. Type of Well: Oil Well [X] Gas Well [ ] Other [ ]
2. Name of Operator Empire Petroleum Corporation - New Mexico
3. Address of Operator 2200 S. Utica Place Suite 150, Tulsa, Oklahoma 74114
4. Well Location Unit Letter L : 2590 feet from the South line and 50 feet from the West line
Section 9 Township 21S Range 36E NMPM County Lea
11. Elevation (Show whether DR, RKB, RT, GR, etc.)

12. Check Appropriate Box to Indicate Nature of Notice, Report or Other Data

NOTICE OF INTENTION TO:
PERFORM REMEDIAL WORK [ ] PLUG AND ABANDON [ ]
TEMPORARILY ABANDON [ ] CHANGE PLANS [ ]
PULL OR ALTER CASING [ ] MULTIPLE COMPL [ ]
DOWNHOLE COMMINGLE [ ]
CLOSED-LOOP SYSTEM [ ]
OTHER: ALS CHANGE - ESP TO PU [X]
SUBSEQUENT REPORT OF:
REMEDIAL WORK [ ] ALTERING CASING [ ]
COMMENCE DRILLING OPNS. [ ] P AND A [ ]
CASING/CEMENT JOB [ ]
OTHER: [ ]

13. Describe proposed or completed operations. (Clearly state all pertinent details, and give pertinent dates, including estimated date of starting any proposed work). SEE RULE 19.15.7.14 NMAC. For Multiple Completions: Attach wellbore diagram of proposed completion or recompletion.

- 1. MIRU WOR and spooler.
2. ND WH and NU BOP.
3. POOH with tbg, cable, and ESP.
4. RIH with TAC and tubing. Set TAC @ 3734'.
5. RIH with rod string configuration and seat pump.
6. Load and test tubing.
7. ND BOP NU WH.
8. MI pumping unit and set base.
9. Notify NMOCD.
10. RDMO.
11. RWTP.

Spud Date:

[Empty box for Spud Date]

Rig Release Date:

[Empty box for Rig Release Date]

I hereby certify that the information above is true and complete to the best of my knowledge and belief.

SIGNATURE Nathan Sandel TITLE Production Engineer DATE 01/29/2025

Type or print name Nathan Sandel E-mail address: nsandel@empirepetrocorp.com PHONE: 918-404-4202

For State Use Only

APPROVED BY: TITLE DATE

Conditions of Approval (if any):

### Current WBD

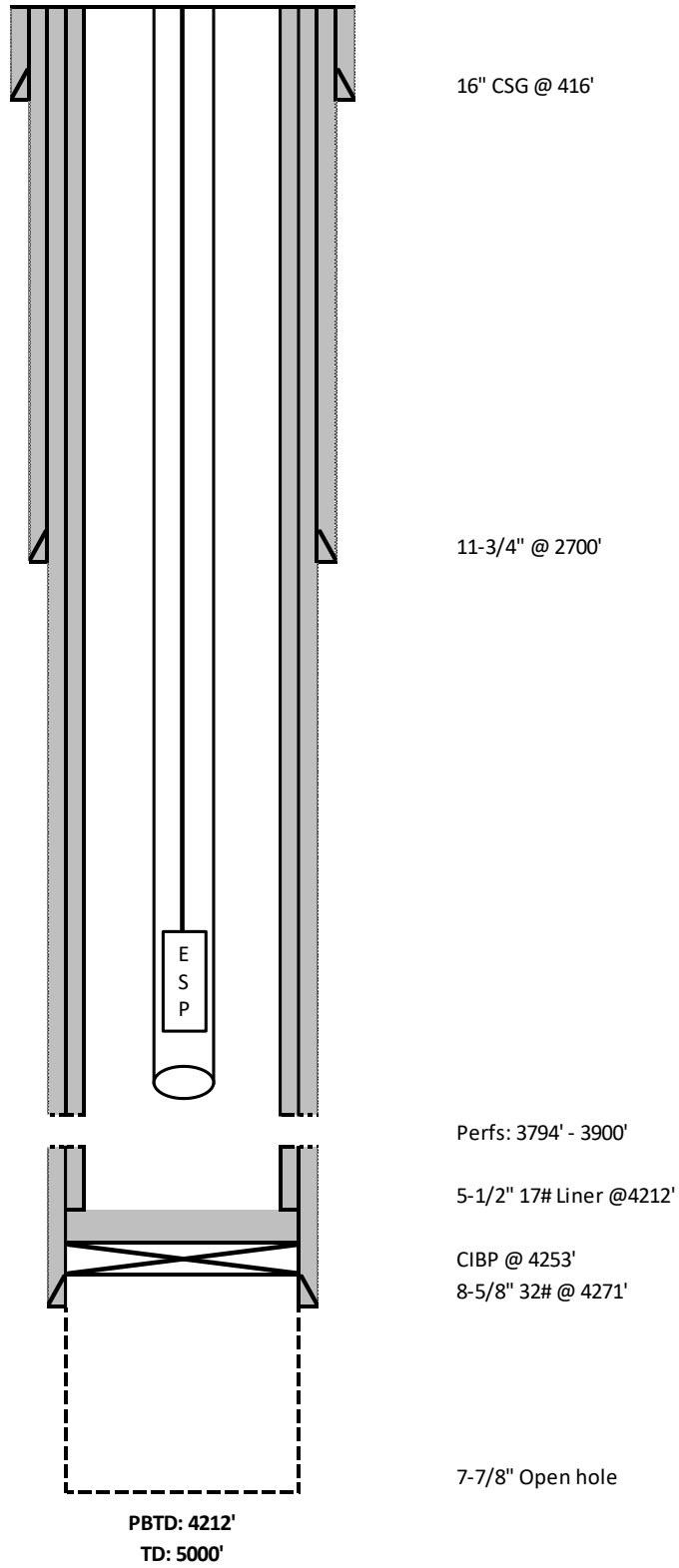

### Proposed WBD

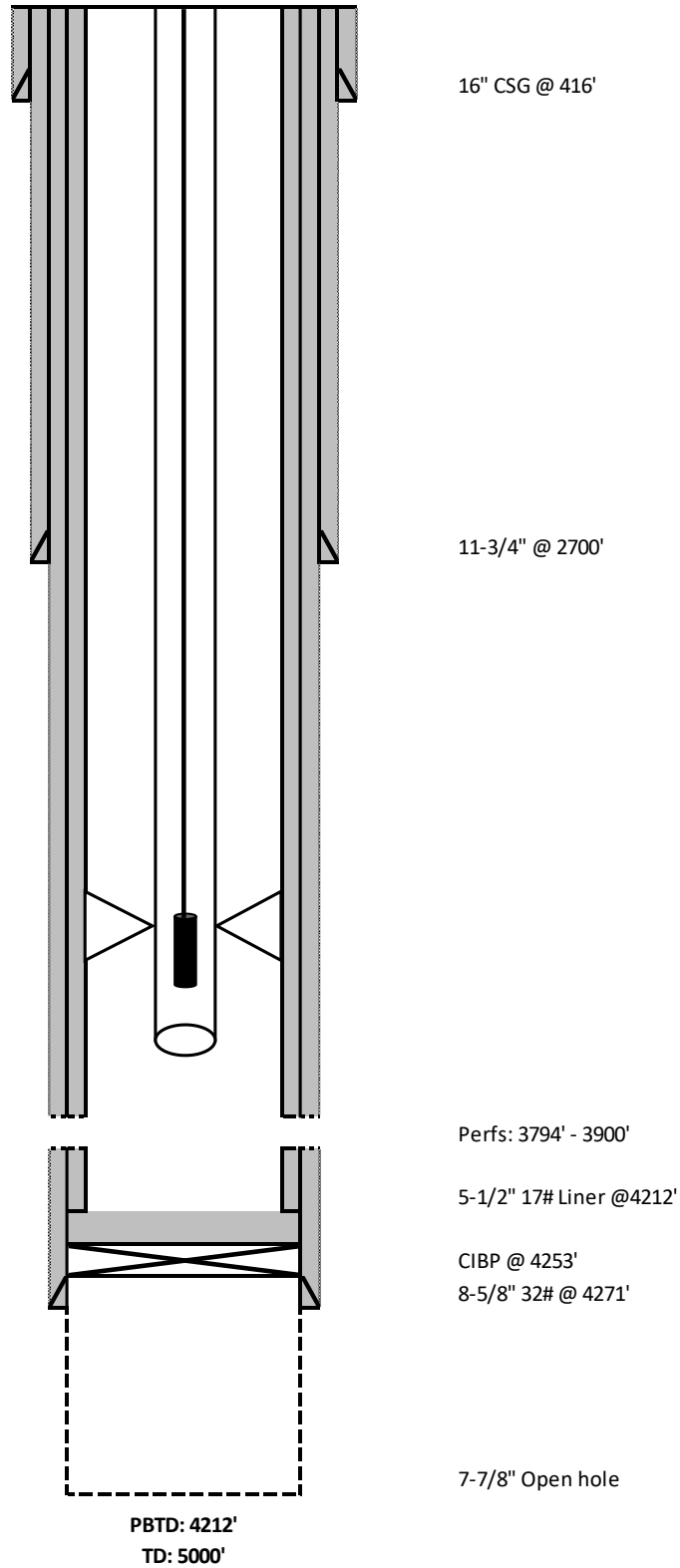

Sante Fe Main Office  
Phone: (505) 476-3441

General Information  
Phone: (505) 629-6116

Online Phone Directory  
<https://www.emnrd.nm.gov/ocd/contact-us>

**State of New Mexico**  
**Energy, Minerals and Natural Resources**  
**Oil Conservation Division**  
**1220 S. St Francis Dr.**  
**Santa Fe, NM 87505**

CONDITIONS

Action 426279

**CONDITIONS**

Operator: Empire New Mexico LLC 2200 S. Utica Place Tulsa, OK 74114	OGRID: 330679
	Action Number: 426279
	Action Type: [C-103] NOI Workover (C-103G)

**CONDITIONS**

Created By	Condition	Condition Date
ward.rikala	Notify the OCD inspection supervisor 24 hours prior to beginning Plug & Abandon (P&A) operations.	4/8/2025
ward.rikala	Subsequent report of operations to be submitted upon completion of work.	4/8/2025