

Form 3160-3
(June 2015)

FORM APPROVED
OMB No. 1004-0137
Expires: January 31, 2018

UNITED STATES
DEPARTMENT OF THE INTERIOR
BUREAU OF LAND MANAGEMENT
APPLICATION FOR PERMIT TO DRILL OR REENTER

1a. Type of work: <input checked="" type="checkbox"/> DRILL <input type="checkbox"/> REENTER		5. Lease Serial No. NMNM65417
1b. Type of Well: <input checked="" type="checkbox"/> Oil Well <input type="checkbox"/> Gas Well <input type="checkbox"/> Other		6. If Indian, Allottee or Tribe Name
1c. Type of Completion: <input type="checkbox"/> Hydraulic Fracturing <input type="checkbox"/> Single Zone <input checked="" type="checkbox"/> Multiple Zone		7. If Unit or CA Agreement, Name and No.
2. Name of Operator OXY USA INCORPORATED		8. Lease Name and Well No. AVID DIVA 35 11 FEDERAL COM 4H
3a. Address P.O. BOX 1002, TUPMAN, CA 93276-1002		9. API Well No. 30-015-57136
3b. Phone No. (include area code) (661) 763-6046		10. Field and Pool, or Exploratory BILBREY BASIN/BONE SPRING
4. Location of Well (Report location clearly and in accordance with any State requirements. *) At surface NESE / 2502 FSL / 913 FEL / LAT 32.4346731 / LONG -103.7430136 At proposed prod. zone SESE / 20 FSL / 594 FEL / LAT 32.3988397 / LONG -103.7419896		11. Sec., T. R. M. or Blk. and Survey or Area SEC 35/T21S/R31E/NMP
14. Distance in miles and direction from nearest town or post office* 23 miles		12. County or Parish EDDY
15. Distance from proposed* location to nearest property or lease line, ft. (Also to nearest drig. unit line, if any) 2502 feet		13. State NM
16. No of acres in lease		17. Spacing Unit dedicated to this well 1599.48
18. Distance from proposed location* to nearest well, drilling, completed, applied for, on this lease, ft. 30 feet		20. BLM/BIA Bond No. in file FED: ESB000226
21. Elevations (Show whether DF, KDB, RT, GL, etc.) 3540 feet		22. Approximate date work will start* 02/01/2026
		23. Estimated duration 45 days
24. Attachments		

The following, completed in accordance with the requirements of Onshore Oil and Gas Order No. 1, and the Hydraulic Fracturing rule per 43 CFR 3162.3-3 (as applicable)

- | | |
|---|---|
| <ul style="list-style-type: none"> 1. Well plat certified by a registered surveyor. 2. A Drilling Plan. 3. A Surface Use Plan (if the location is on National Forest System Lands, the SUPO must be filed with the appropriate Forest Service Office). | <ul style="list-style-type: none"> 4. Bond to cover the operations unless covered by an existing bond on file (see Item 20 above). 5. Operator certification. 6. Such other site specific information and/or plans as may be requested by the BLM. |
|---|---|

25. Signature (Electronic Submission)	Name (Printed/Typed) MELISSA GUIDRY / Ph: (713) 366-5716	Date 02/04/2025
Title Advisor Regulatory Sr.		
Approved by (Signature) (Electronic Submission)	Name (Printed/Typed) CHRISTOPHER WALLS / Ph: (575) 234-2234	Date 07/11/2025
Title Petroleum Engineer		

Application approval does not warrant or certify that the applicant holds legal or equitable title to those rights in the subject lease which would entitle the applicant to conduct operations thereon.
Conditions of approval, if any, are attached.

Title 18 U.S.C. Section 1001 and Title 43 U.S.C. Section 1212, make it a crime for any person knowingly and willfully to make to any department or agency of the United States any false, fictitious or fraudulent statements or representations as to any matter within its jurisdiction.



(Continued on page 2)

*(Instructions on page 2)

INSTRUCTIONS

GENERAL: This form is designed for submitting proposals to perform certain well operations, as indicated on Federal and Indian lands and leases for action by appropriate Federal agencies, pursuant to applicable Federal laws and regulations. Any necessary special instructions concerning the use of this form and the number of copies to be submitted, particularly with regard to local, area, or regional procedures and practices, either are shown below or will be issued by, or may be obtained from local Federal offices.

ITEM I: If the proposal is to redrill to the same reservoir at a different subsurface location or to a new reservoir, use this form with appropriate notations. Consult applicable Federal regulations concerning subsequent work proposals or reports on the well.

ITEM 4: Locations on Federal or Indian land should be described in accordance with Federal requirements. Consult local Federal offices for specific instructions.

ITEM 14: Needed only when location of well cannot readily be found by road from the land or lease description. A plat, or plats, separate or on the reverse side, showing the roads to, and the surveyed location of, the well, and any other required information, should be furnished when required by Federal agency offices.

ITEMS 15 AND 18: If well is to be, or has been directionally drilled, give distances for subsurface location of hole in any present or objective productive zone.

ITEM 22: Consult applicable Federal regulations, or appropriate officials, concerning approval of the proposal before operations are started.

ITEM 24: If the proposal will involve hydraulic fracturing operations, you must comply with 43 CFR 3162.3-3, including providing information about the protection of usable water. Operators should provide the best available information about all formations containing water and their depths. This information could include data and interpretation of resistivity logs run on nearby wells. Information may also be obtained from state or tribal regulatory agencies and from local BLM offices.

NOTICES

The Privacy Act of 1974 and regulation in 43 CFR 2.48(d) provide that you be furnished the following information in connection with information required by this application.

AUTHORITY: 30 U.S.C. 181 et seq., 25 U.S.C. 396; 43 CFR 3160

PRINCIPAL PURPOSES: The information will be used to: (1) process and evaluate your application for a permit to drill a new oil, gas, or service well or to reenter a plugged and abandoned well; and (2) document, for administrative use, information for the management, disposal and use of National Resource Lands and resources including (a) analyzing your proposal to discover and extract the Federal or Indian resources encountered; (b) reviewing procedures and equipment and the projected impact on the land involved; and (c) evaluating the effects of the proposed operation on the surface and subsurface water and other environmental impacts.

ROUTINE USE: Information from the record and/or the record will be transferred to appropriate Federal, State, and local or foreign agencies, when relevant to civil, criminal or regulatory investigations or prosecution, in connection with congressional inquiries and for regulatory responsibilities.

EFFECT OF NOT PROVIDING INFORMATION: Filing of this application and disclosure of the information is mandatory only if you elect to initiate a drilling or reentry operation on an oil and gas lease.

The Paperwork Reduction Act of 1995 requires us to inform you that:

The BLM connects this information to a new evaluation of the technical, safety, and environmental factors involved with drilling for oil and/or gas on Federal and Indian oil and gas leases. This information will be used to analyze and approve applications. Response to this request is mandatory only if the operator elects to initiate drilling or reentry operations on an oil and gas lease. The BLM would like you to know that you do not have to respond to this or any other Federal agency-sponsored information collection unless it displays a currently valid OMB control number.

BURDEN HOURS STATEMENT: Public reporting burden for this form is estimated to average 8 hours per response, including the time for reviewing instructions, gathering and maintaining data, and completing and reviewing the form. Direct comments regarding the burden estimate or any other aspect of this form to U.S. Department of the Interior, Bureau of Land Management (1004-0137), Bureau Information Connection Clearance Officer (WO-630), 1849 C Street, N.W., Mail Stop 401 LS, Washington, D.C. 20240.

Additional Operator Remarks

Location of Well

0. SHL: NESE / 2502 FSL / 913 FEL / TWSP: 21S / RANGE: 31E / SECTION: 35 / LAT: 32.4346731 / LONG: -103.7430136 (TVD: 0 feet, MD: 0 feet)

PPP: NESE / 2542 FSL / 595 FEL / TWSP: 21S / RANGE: 31E / SECTION: 35 / LAT: 32.4347843 / LONG: -103.7419842 (TVD: 9735 feet, MD: 10089 feet)

PPP: NENE / 0 FSL / 594 FEL / TWSP: 22S / RANGE: 31E / SECTION: 11 / LAT: 32.4133056 / LONG: -103.7419894 (TVD: 9735 feet, MD: 17381 feet)

BHL: SESE / 20 FSL / 594 FEL / TWSP: 22S / RANGE: 31E / SECTION: 11 / LAT: 32.3988397 / LONG: -103.7419896 (TVD: 9735 feet, MD: 22644 feet)

BLM Point of Contact

Name: TENILLE C MOLINA

Title: Land Law Examiner

Phone: (575) 234-2224

Email: TCMOLINA@BLM.GOV

Review and Appeal Rights

A person contesting a decision shall request a State Director review. This request must be filed within 20 working days of receipt of the Notice with the appropriate State Director (see 43 CFR 3165.3). The State Director review decision may be appealed to the Interior Board of Land Appeals, 801 North Quincy Street, Suite 300, Arlington, VA 22203 (see 43 CFR 3165.4). Contact the above listed Bureau of Land Management office for further information.

AVID DIVA 35_11 FED COM 4H

ACREAGE DEDICATION PLATS

PAGE 2 OF 2

SHL (NAD83)
X:723462.38' / Y:522368.41'
LAT:32.43467319 / LON:-103.74301364

SHL (NAD27)
X:682280.58' / Y:522307.51'
LAT:32.43455087 / LON:-103.74252252

KOP (NAD83)
X:723779.46' / Y:522460.59'
LAT:32.43492175 / LON:-103.74198428

KOP (NAD27)
X:682597.66' / Y:522399.69'
LAT:32.43479943 / LON:-103.74149318

FTP (NAD83)
X:723779.76' / Y:522410.59'
LAT:32.43478432 / LON:-103.74198421

FTP (NAD27)
X:682597.96' / Y:522349.70'
LAT:32.43466199 / LON:-103.74149312

PPP-1 (NAD83)
X:723821.38' / Y:514596.62'
LAT:32.41330562 / LON:-103.74198945

PPP-1 (NAD27)
X:682639.35' / Y:514535.93'
LAT:32.41318318 / LON:-103.74149922

LTP (NAD83)
X:723848.99' / Y:509413.92'
LAT:32.39905961 / LON:-103.74199288

LTP (NAD27)
X:682666.81' / Y:509353.36'
LAT:32.39893710 / LON:-103.74150322

BHL (NAD83)
X:723850.42' / Y:509333.92'
LAT:32.39883972 / LON:-103.74198969

BHL (NAD27)
X:682668.23' / Y:509273.37'
LAT:32.39871721 / LON:-103.74150004

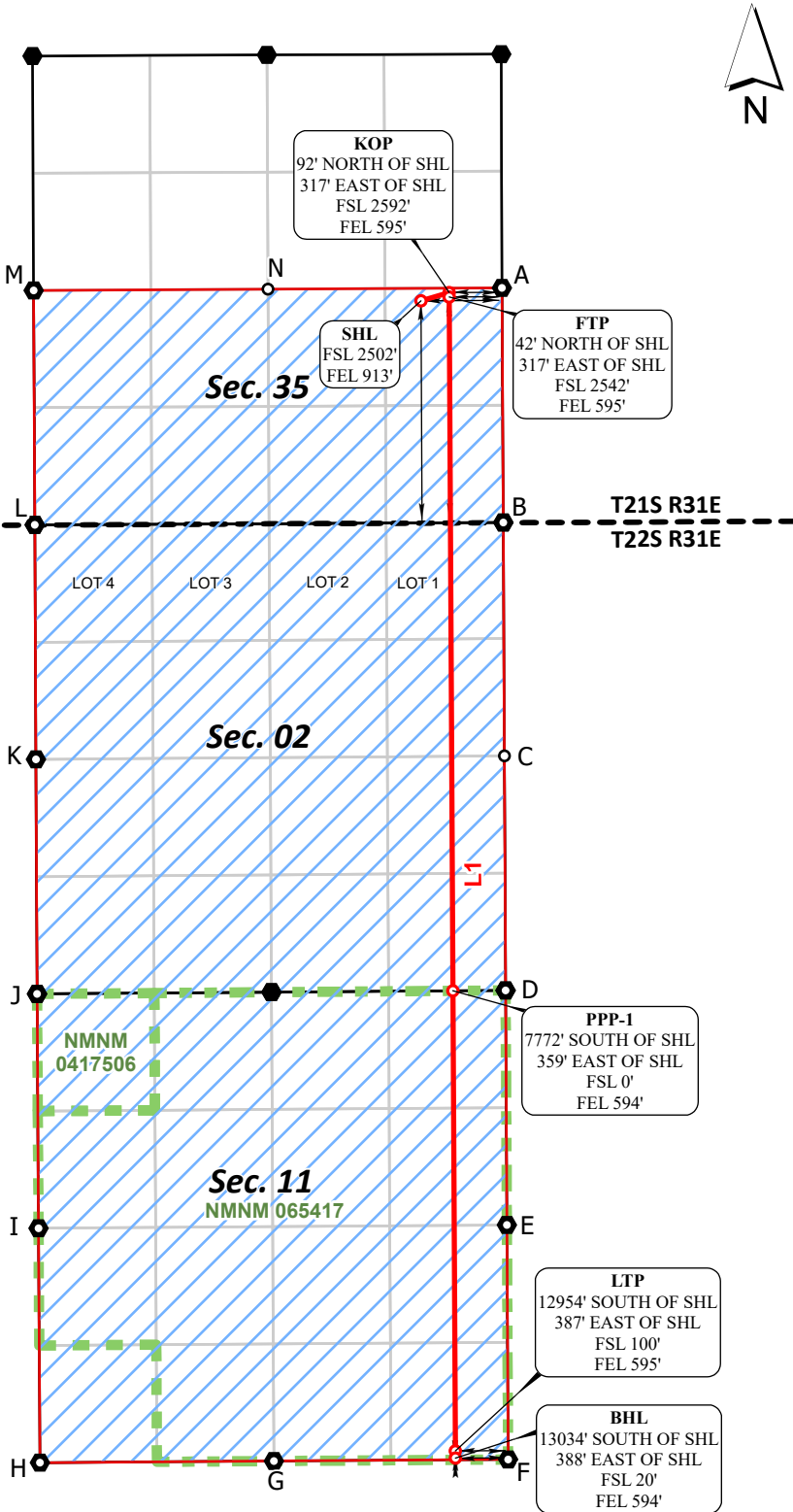

CORNER COORDINATES NAD 83, SPCS NM EAST

A - X: 724374.15' / Y:522513.80'
B - X: 724389.93' / Y:519871.47'
C - X: 724402.79' / Y:517243.04'
D - X: 724415.68' / Y:514601.05'
E - X: 724430.42' / Y:511959.39'
F - X: 724444.51' / Y:509317.86'
G - X: 721804.87' / Y:509300.38'
H - X: 719168.23' / Y:509282.33'
I - X: 719152.56' / Y:511922.16'
J - X: 719135.94' / Y:514561.78'
K - X: 719123.52' / Y:517203.74'
L - X: 719110.16' / Y:519844.97'
M - X: 719097.63' / Y:522485.35'
N - X: 721738.13' / Y:522499.58'

CORNER COORDINATES NAD 27, SPCS NM EAST

A - X: 683192.35' / Y:522452.90'
B - X: 683208.05' / Y:519810.64'
C - X: 683220.83' / Y:517182.28'
D - X: 683233.65' / Y:514540.36'
E - X: 683248.31' / Y:511898.77'
F - X: 683262.32' / Y:509257.30'
G - X: 680622.69' / Y:509239.83'
H - X: 677986.06' / Y:509221.79'
I - X: 677970.48' / Y:511861.55'
J - X: 677953.93' / Y:514501.10'
K - X: 677941.59' / Y:517142.99'
L - X: 677928.31' / Y:519784.15'
M - X: 677915.86' / Y:522424.46'
N - X: 680556.35' / Y:522438.69'

***FTP TO LTP LINE BEARINGS**

LINE	BEARING
L1	S 00°18'19" E ~ 12996.86'

***FTP TO LTP LEASE DISTANCES**

TRACT	DISTANCE
NMNM 065417	5182.77'
TOTAL	5182.77'

○ Drill Line Events ● Section Corners — Drill Line ← Dimension Lines □ Federal Leases □ HSU ● HSU Corners

All bearings and coordinates refer to New Mexico State Plane Coordinate System, East Zone, U.S. Survey Feet.



JOB No. R4223_008_14282
REV 1 NDS 12/19/2024

Distances/areas relative to NAD 83 grid measurements. Combined Scale Factor: 0.99977748 and a Convergence Angle: 0.31355882°

State of New Mexico
Energy, Minerals and Natural Resources Department

Submit Electronically
Via E-permitting

Oil Conservation Division
1220 South St. Francis Dr.
Santa Fe, NM 87505

NATURAL GAS MANAGEMENT PLAN

This Natural Gas Management Plan must be submitted with each Application for Permit to Drill (APD) for a new or recompleted well.

Section 1 – Plan Description

Effective May 25, 2021

I. Operator: OXY USA INC. **OGRID:** 16696 **Date:** 0 1/ 3 1/ 2 5

II. Type: Original Amendment due to 19.15.27.9.D(6)(a) NMAC 19.15.27.9.D(6)(b) NMAC Other.

If Other, please describe: _____

III. Well(s): Provide the following information for each new or recompleted well or set of wells proposed to be drilled or proposed to be recompleted from a single well pad or connected to a central delivery point.

Well Name	API	ULSTR	Footages	Anticipated Oil BBL/D	Anticipated Gas MCF/D	Anticipated Produced Water BBL/D
SEE ATTACHED						

IV. Central Delivery Point Name: Lost Tank 35 Central Processing Facility [See 19.15.27.9(D)(1) NMAC]

V. Anticipated Schedule: Provide the following information for each new or recompleted well or set of wells proposed to be drilled or proposed to be recompleted from a single well pad or connected to a central delivery point.

Well Name	API	Spud Date	TD Reached Date	Completion Commencement Date	Initial Flow Back Date	First Production Date
SEE ATTACHED						

VI. Separation Equipment: Attach a complete description of how Operator will size separation equipment to optimize gas capture.

VII. Operational Practices: Attach a complete description of the actions Operator will take to comply with the requirements of Subsection A through F of 19.15.27.8 NMAC.

VIII. Best Management Practices: Attach a complete description of Operator’s best management practices to minimize venting during active and planned maintenance.

Section 2 – Enhanced Plan
EFFECTIVE APRIL 1, 2022

Beginning April 1, 2022, an operator that is not in compliance with its statewide natural gas capture requirement for the applicable reporting area must complete this section.

Operator certifies that it is not required to complete this section because Operator is in compliance with its statewide natural gas capture requirement for the applicable reporting area.

IX. Anticipated Natural Gas Production:

Well	API	Anticipated Average Natural Gas Rate MCF/D	Anticipated Volume of Natural Gas for the First Year MCF

X. Natural Gas Gathering System (NGGS):

Operator	System	ULSTR of Tie-in	Anticipated Gathering Start Date	Available Maximum Daily Capacity of System Segment Tie-in

XI. Map. Attach an accurate and legible map depicting the location of the well(s), the anticipated pipeline route(s) connecting the production operations to the existing or planned interconnect of the natural gas gathering system(s), and the maximum daily capacity of the segment or portion of the natural gas gathering system(s) to which the well(s) will be connected.

XII. Line Capacity. The natural gas gathering system will will not have capacity to gather 100% of the anticipated natural gas production volume from the well prior to the date of first production.

XIII. Line Pressure. Operator does does not anticipate that its existing well(s) connected to the same segment, or portion, of the natural gas gathering system(s) described above will continue to meet anticipated increases in line pressure caused by the new well(s).

Attach Operator’s plan to manage production in response to the increased line pressure.

XIV. Confidentiality: Operator asserts confidentiality pursuant to Section 71-2-8 NMSA 1978 for the information provided in Section 2 as provided in Paragraph (2) of Subsection D of 19.15.27.9 NMAC, and attaches a full description of the specific information for which confidentiality is asserted and the basis for such assertion.

Section 3 - Certifications

Effective May 25, 2021

Operator certifies that, after reasonable inquiry and based on the available information at the time of submittal:

Operator will be able to connect the well(s) to a natural gas gathering system in the general area with sufficient capacity to transport one hundred percent of the anticipated volume of natural gas produced from the well(s) commencing on the date of first production, taking into account the current and anticipated volumes of produced natural gas from other wells connected to the pipeline gathering system; or

Operator will not be able to connect to a natural gas gathering system in the general area with sufficient capacity to transport one hundred percent of the anticipated volume of natural gas produced from the well(s) commencing on the date of first production, taking into account the current and anticipated volumes of produced natural gas from other wells connected to the pipeline gathering system.

If Operator checks this box, Operator will select one of the following:

Well Shut-In. Operator will shut-in and not produce the well until it submits the certification required by Paragraph (4) of Subsection D of 19.15.27.9 NMAC; or

Venting and Flaring Plan. Operator has attached a venting and flaring plan that evaluates and selects one or more of the potential alternative beneficial uses for the natural gas until a natural gas gathering system is available, including:

- (a) power generation on lease;
- (b) power generation for grid;
- (c) compression on lease;
- (d) liquids removal on lease;
- (e) reinjection for underground storage;
- (f) reinjection for temporary storage;
- (g) reinjection for enhanced oil recovery;
- (h) fuel cell production; and
- (i) other alternative beneficial uses approved by the division.

Section 4 - Notices

1. If, at any time after Operator submits this Natural Gas Management Plan and before the well is spud:

(a) Operator becomes aware that the natural gas gathering system it planned to connect the well(s) to has become unavailable or will not have capacity to transport one hundred percent of the production from the well(s), no later than 20 days after becoming aware of such information, Operator shall submit for OCD's approval a new or revised venting and flaring plan containing the information specified in Paragraph (5) of Subsection D of 19.15.27.9 NMAC; or

(b) Operator becomes aware that it has, cumulatively for the year, become out of compliance with its baseline natural gas capture rate or natural gas capture requirement, no later than 20 days after becoming aware of such information, Operator shall submit for OCD's approval a new or revised Natural Gas Management Plan for each well it plans to spud during the next 90 days containing the information specified in Paragraph (2) of Subsection D of 19.15.27.9 NMAC, and shall file an update for each Natural Gas Management Plan until Operator is back in compliance with its baseline natural gas capture rate or natural gas capture requirement.

2. OCD may deny or conditionally approve an APD if Operator does not make a certification, fails to submit an adequate venting and flaring plan which includes alternative beneficial uses for the anticipated volume of natural gas produced, or if OCD determines that Operator will not have adequate natural gas takeaway capacity at the time a well will be spud.

I certify that, after reasonable inquiry, the statements in and attached to this Natural Gas Management Plan are true and correct to the best of my knowledge and acknowledge that a false statement may be subject to civil and criminal penalties under the Oil and Gas Act.

Signature: <i>Melissa Guidry</i>
Printed Name: Melissa Guidry
Title: Regulatory Advisor Sr.
E-mail Address: melissa_guidry@oxy.com
Date: 01/31/25
Phone: 713-497-2481

OIL CONSERVATION DIVISION
(Only applicable when submitted as a standalone form)

Approved By:
Title:
Approval Date:
Conditions of Approval:

V. Anticipated Schedule

Well Name	API	WELL LOCATION (ULSTR)	Footages	ANTICIPATED OIL BBL/D	ANTICIPATED GAS MCF/D	ANTICIPATED PROD WATER BBL/D
AVID DIVA 35_11 FED COM 11H	Pending	K-35-T21S-R31E	2348 FSL 1518 FWL	1500	8500	4000
AVID DIVA 35_11 FED COM 12H	Pending	K-35-T21S-R31E	2348 FSL 1548 FWL	1500	8500	4000
AVID DIVA 35_11 FED COM 1H	Pending	K-35-T21S-R31E	2348 FSL 1608 FWL	2250	5000	3500
AVID DIVA 35_11 FED COM 21H	Pending	K-35-T21S-R31E	2348 FSL 1430 FWL	1600	2000	5500
AVID DIVA 35_11 FED COM 22H	Pending	K-35-T21S-R31E	2348 FSL 1458 FWL	1600	2000	5500
AVID DIVA 35_11 FED COM 2H	Pending	K-35-T21S-R31E	2348 FSL 1638 FWL	2250	5000	3500
AVID DIVA 35_11 FED COM 31H	Pending	K-35-T21S-R31E	2473 FSL 1548 FWL	4000	6000	9000
AVID DIVA 35_11 FED COM 32H	Pending	K-35-T21S-R31E	2473 FSL 1578 FWL	4000	6000	9000
AVID DIVA 35_11 FED COM 33H	Pending	K-35-T21S-R31E	2473 FSL 1608 FWL	4000	6000	9000
AVID DIVA 35_11 FED COM 34H	Pending	K-35-T21S-R31E	2472 FSL 1638 FWL	4000	6000	9000
AVID DIVA 35_11 FED COM 41H	Pending	K-35-T21S-R31E	2474 FSL 1368 FWL	1000	10000	1500
AVID DIVA 35_11 FED COM 42H	Pending	K-35-T21S-R31E	2474 FSL 1398 FWL	1000	10000	1500
AVID DIVA 35_11 FED COM 71H	Pending	K-35-T21S-R31E	2473 FSL 1458 FWL	1500	1500	6500
AVID DIVA 35_11 FED COM 72H	Pending	K-35-T21S-R31E	2473 FSL 1488 FWL	1500	1500	6500
AVID DIVA 35_11 FED COM 3H	Pending	I-35-T21S-R31E	2503 FSL 943 FEL	2250	5000	3500
AVID DIVA 35_11 FED COM 4H	Pending	I-35-T21S-R31E	2502 FSL 913 FEL	2250	5000	3500

V. Anticipated Schedule

Well Name	API	Spud Date	TD Reached Date	Completion Commencement Date	Initial Flow Back Date	First Production Date
AVID DIVA 35_11 FED COM 11H	Pending	1/1/2027	01/31/2027	03/02/2027	04/16/2027	04/17/2027
AVID DIVA 35_11 FED COM 12H	Pending	1/1/2027	01/31/2027	03/02/2027	04/16/2027	04/17/2027
AVID DIVA 35_11 FED COM 1H	Pending	1/1/2027	01/31/2027	03/02/2027	04/16/2027	04/17/2027
AVID DIVA 35_11 FED COM 21H	Pending	1/1/2027	01/31/2027	03/02/2027	04/16/2027	04/17/2027
AVID DIVA 35_11 FED COM 22H	Pending	1/1/2027	01/31/2027	03/02/2027	04/16/2027	04/17/2027
AVID DIVA 35_11 FED COM 2H	Pending	1/1/2027	01/31/2027	03/02/2027	04/16/2027	04/17/2027
AVID DIVA 35_11 FED COM 31H	Pending	1/1/2027	01/31/2027	03/02/2027	04/16/2027	04/17/2027
AVID DIVA 35_11 FED COM 32H	Pending	1/1/2027	01/31/2027	03/02/2027	04/16/2027	04/17/2027
AVID DIVA 35_11 FED COM 33H	Pending	1/1/2027	01/31/2027	03/02/2027	04/16/2027	04/17/2027
AVID DIVA 35_11 FED COM 34H	Pending	1/1/2027	01/31/2027	03/02/2027	04/16/2027	04/17/2027
AVID DIVA 35_11 FED COM 41H	Pending	6/1/2027	07/01/2027	07/31/2027	09/14/2027	09/15/2027
AVID DIVA 35_11 FED COM 42H	Pending	6/1/2027	07/01/2027	07/31/2027	09/14/2027	09/15/2027
AVID DIVA 35_11 FED COM 71H	Pending	6/1/2027	07/01/2027	07/31/2027	09/14/2027	09/15/2027
AVID DIVA 35_11 FED COM 72H	Pending	1/1/2027	01/31/2027	03/02/2027	04/16/2027	04/17/2027
AVID DIVA 35_11 FED COM 3H	Pending	1/1/2027	01/31/2027	03/02/2027	04/16/2027	04/17/2027
AVID DIVA 35_11 FED COM 4H	Pending	1/1/2027	01/31/2027	03/02/2027	04/16/2027	04/17/2027

Central Delivery Point Name : Lost Tank 35 Central Processing Facility

Part VI. Separation Equipment

Operator will size the flowback separator to handle 12,000 Bbls of fluid and 6-10MMscfd which is more than the expected peak rates for these wells. Each separator is rated to 1440psig, and pressure control valves and automated communication will cause the wells to shut in in the event of an upset at the facility, therefore no gas will be flared on pad during an upset. Current Oxy practices avoid use of flare or venting on pad, therefore if there is an upset or emergency condition at the facility, the wells will immediately shut down, and reassume production once the condition has cleared.

VII. Operational Practices

Gathering System and Pipeline Notification

Well(s) will be connected to a production facility and fluids will be sent to the facility after initial flowback operations are complete, where a gas transporter system is in place. The gas produced from production facility will be dedicated to MarkWest Energy West Texas Gas Company LLC ("MarkWest") and will be connected to MarkWest's high pressure gathering system located in Lea and Eddy Counties, New Mexico and Loving and Culberson Counties, TX. OXY USA INC. ("OXY") will provide (periodically) to MarkWest a production forecast for wells being sent to their system. In addition, OXY and MarkWest will have periodic conference calls to discuss changes to production forecasts arising out of changes to drilling and completion schedules. Gas from these wells will be processed at MarWest's Preakness and Tornado Processing Plants located in Culberson County, TX and Loving County, Texas respectively. The actual flow of the gas will be based on compression operating parameters and gathering system pressures

Flowback Strategy

After the fracture treatment/completion operations, well(s) will be produced to temporary production tanks and gas will be flared or vented. During flowback, the fluids and sand content will be monitored. When the produced fluids contain minimal sand, the wells will be turned to production facilities. Gas sales should start as soon as the wells start flowing through the production facilities, unless there are operational issues on MPLX system at that time. Based on current information, it is OXY's belief the system can take this gas upon completion of the well(s). Safety requirements during cleanout operations from the use of underbalanced air cleanout systems may necessitate that sand and non-pipeline quality gas be vented and/or flared rather than sold on a temporary basis.

VIII. Best Management Practices

Alternatives to Reduce Flaring

Below are alternatives considered from a conceptual standpoint to reduce the amount of gas flared.

Power Generation – On lease

Only a portion of gas is consumed operating the generator, remainder of gas will be flared

Compressed Natural Gas – On lease

Gas flared would be minimal, but might be uneconomical to operate when gas volume declines

NGL Removal – On lease

Plants are expensive, residue gas is still flared, and uneconomical to operate when gas volume declines

TANKS BONESPRING	
Oil (bbl/d)	Gas (mcf/d)
Jan-2024	1,006
Feb-2024	1,133
Mar-2024	938
Apr-2024	790
May-2024	681
Jun-2024	596
Jul-2024	530
Aug-2024	477
Sep-2024	432
Oct-2024	395
Nov-2024	363
Dec-2024	337
Jan-2025	314
Feb-2025	293
Mar-2025	274
Apr-2025	258
May-2025	243
Jun-2025	229
Jul-2025	218
Aug-2025	207
Sep-2025	197
Oct-2025	188
Nov-2025	179
Dec-2025	172
Jan-2026	165
Feb-2026	159
Mar-2026	152
Apr-2026	147
May-2026	141
Jun-2026	136
Jul-2026	132
Aug-2026	127
Sep-2026	123
Oct-2026	120
Nov-2026	116
Dec-2026	112

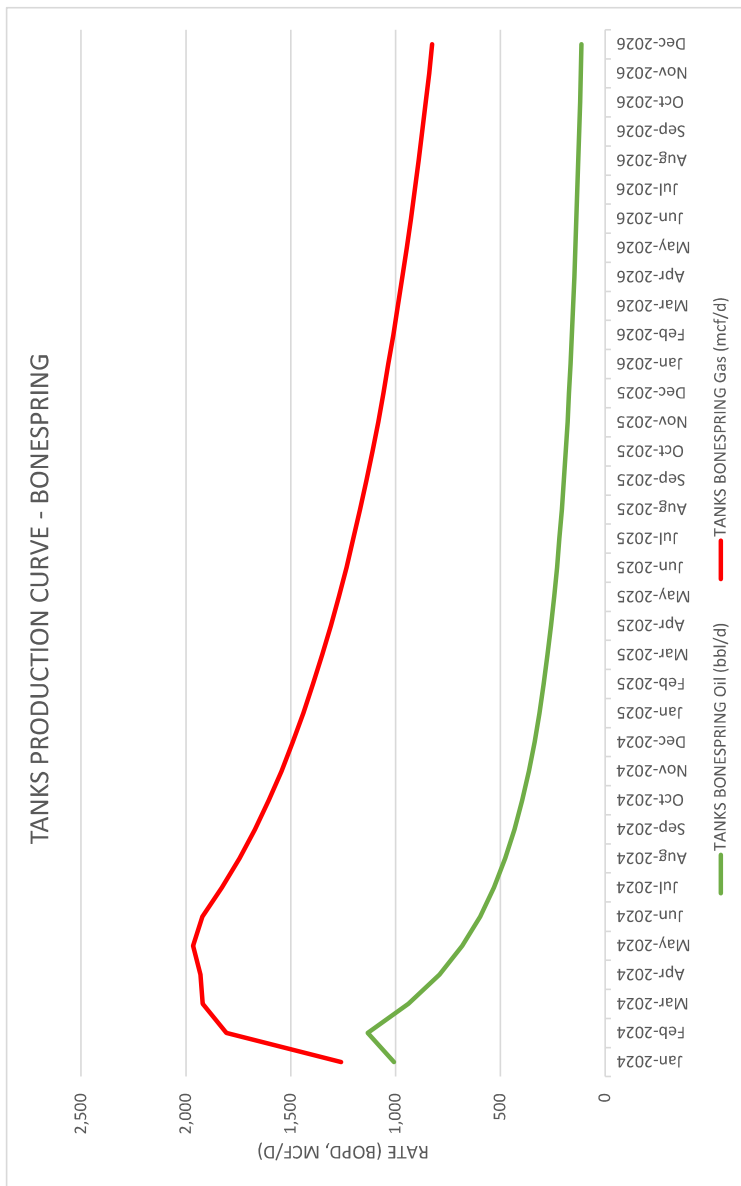

TANKS WOLF CAMP		
	Oil (bbl/d)	Gas (mcf/d)
Jan-2024	2,008	3,461
Feb-2024	1,671	2,856
Mar-2024	1,182	2,118
Apr-2024	921	1,733
May-2024	758	1,490
Jun-2024	644	1,317
Jul-2024	562	1,190
Aug-2024	500	1,091
Sep-2024	450	1,011
Oct-2024	410	944
Nov-2024	376	887
Dec-2024	349	841
Jan-2025	325	800
Feb-2025	304	763
Mar-2025	286	730
Apr-2025	270	700
May-2025	256	674
Jun-2025	243	649
Jul-2025	231	627
Aug-2025	221	607
Sep-2025	211	589
Oct-2025	203	571
Nov-2025	194	555
Dec-2025	187	541
Jan-2026	181	528
Feb-2026	175	515
Mar-2026	169	502
Apr-2026	163	491
May-2026	158	480
Jun-2026	153	470
Jul-2026	149	460
Aug-2026	145	451
Sep-2026	141	442
Oct-2026	137	434
Nov-2026	133	426
Dec-2026	130	419

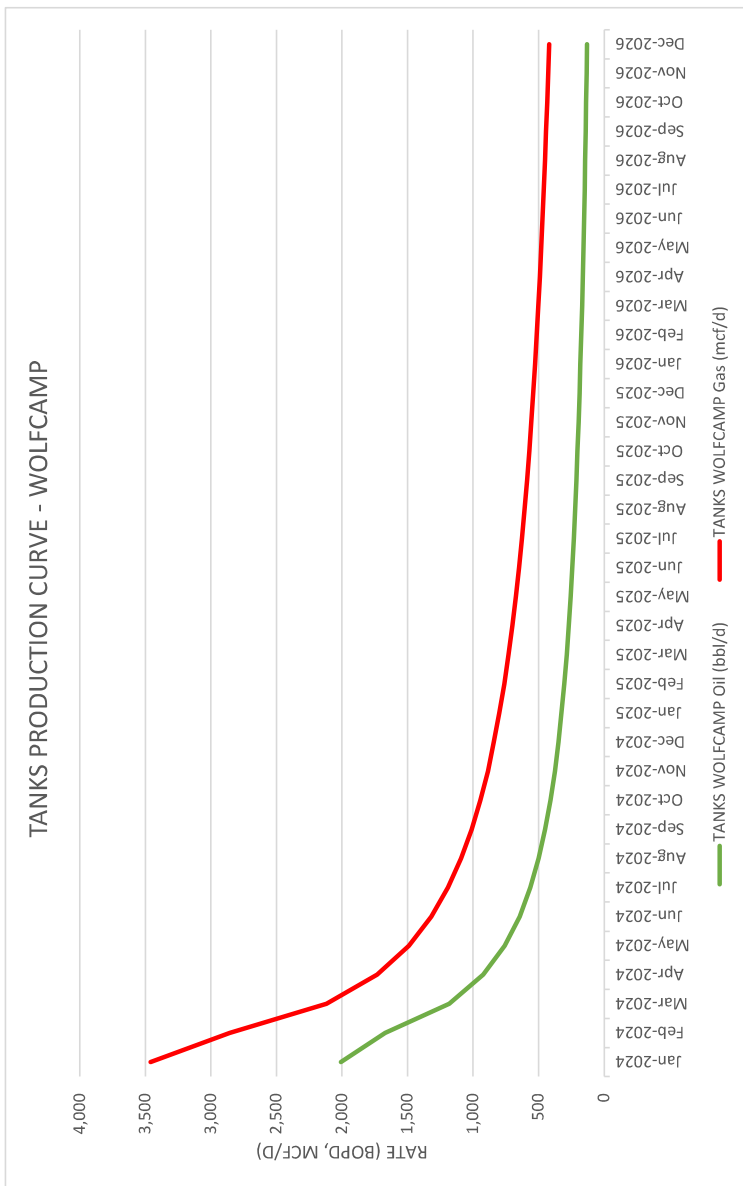

Oxy USA Inc. - AVID DIVA 35_11 Fed Com 4H Drill Plan

1. Geologic Formations

TVD of Target (ft):	9735	Pilot Hole Depth (ft):	
Total Measured Depth (ft):	22644	Deepest Expected Fresh Water (ft):	709

Delaware Basin

Formation	MD-RKB (ft)	TVD-RKB (ft)	Expected Fluids
Rustler	709	709	
Salado	1011	1011	Salt
Castile	2621	2621	Salt
Delaware	4321	4321	Oil/Gas/Brine
Bell Canyon	4425	4425	Oil/Gas/Brine
Cherry Canyon	5244	5244	Oil/Gas/Brine
Brushy Canyon	6548	6548	Losses
Bone Spring	8282	8276	Oil/Gas
Bone Spring 1st	9374	9349	Oil/Gas
Bone Spring 2nd			Oil/Gas
Bone Spring 3rd			Oil/Gas
Wolfcamp			Oil/Gas
Penn			Oil/Gas
Strawn			Oil/Gas

*H2S, water flows, loss of circulation, abnormal pressures, etc.

2. Casing Program

Section	Hole Size (in)	MD		TVD		Csg. OD (in)	Csg Wt. (ppf)	Grade	Conn.
		From (ft)	To (ft)	From (ft)	To (ft)				
Surface	17.5	0	769	0	769	13.375	54.5	J-55	BTC
Salt	12.25	0	4321	0	4321	10.75	45.5	L-80 HC	BTC-SC
Intermediate	9.875	0	9051	0	9032	7.625	26.4	L-80 HC	BTC
Production	6.75	0	22644	0	9735	5.5	20	P-110	Sprint-SF

All casing strings will be tested in accordance with 43 CFR part 3170 Subpart 3172

All Casing SF Values will meet or exceed those below			
SF Collapse	SF Burst	Body SF Tension	Joint SF Tension
1.00	1.100	1.4	1.4

	Y or N
Is casing new? If used, attach certification as required in 43 CFR 3160	Y
Does casing meet API specifications? If no, attach casing specification sheet.	Y
Is premium or uncommon casing planned? If yes attach casing specification sheet.	Y
Does the above casing design meet or exceed BLM's minimum standards? If not provide justification (loading assumptions, casing design criteria).	Y
Will the intermediate pipe be kept at a minimum 1/3 fluid filled to avoid approaching the collapse pressure rating of the casing?	Y
Capitan Reef	
Is well located within Capitan Reef?	N
If yes, does production casing cement tie back a minimum of 50' above the Reef?	
Is well within the designated 4 string boundary.	
SOPA	
Is well located in SOPA but not in R-111-P?	N
If yes, are the first 2 strings cemented to surface and 3 rd string cement tied back 500' into previous casing?	
R-111-P and SOPA	
Is well located in R-111-P and SOPA?	Y
If yes, are the first three strings cemented to surface?	Y
Is 2 nd string set 100' to 600' below the base of salt?	Y
High Cave/Karst	
Is well located in high Cave/Karst?	N
If yes, are there two strings cemented to surface?	
(For 2 string wells) If yes, is there a contingency casing if lost circulation occurs?	
Critical Cave/Karst	
Is well located in critical Cave/Karst?	N
If yes, are there three strings cemented to surface?	

3. Cementing Program

Section	Stage	Slurry:	Sacks	Yield (ft ³ /ft)	Density (lb/gal)	Excess:	TOC	Placement	Description
Surface	1	Surface - Tail	803	1.33	14.8	100%	-	Circulate	Class C+Accel.
Int.1	1	Intermediate - Tail	85	1.33	14.8	20%	3,821	Circulate	Class C+Accel.
Int.1	1	Intermediate - Lead	604	1.73	12.9	50%	-	Circulate	Class Pozz+Ret.
Int. 2	1	Intermediate 1S - Tail	302	1.68	13.2	5%	6,798	Circulate	Class C+Ret., Disper.
Int. 2	2	Intermediate 2S - Tail BH	454	1.71	13.3	25%	3,821	Bradenhead Post-Frac	Class C+Accel.
Prod.	1	Production - Tail	798	1.84	13.3	25%	8,551	Circulate	Class C+Ret.

Offline Cementing Request

Oxy requests a variance to cement the 9.625" and/or 7.625" intermediate casing strings offline in accordance to the approved variance, EC Tran 461365. Please see Offline Cementing Variance attachment for further details.

Bradenhead CBL Request

Oxy requests permission to adjust the CBL requirement after bradenhead cement jobs, on 7-5/8" intermediate casings, as per the agreement reached in the OXY/BLM meeting on September 5, 2019. Please see Bradenhead CBL Variance attachment for further details.

4. Pressure Control Equipment

BOP installed and tested before drilling which hole?	Size?	Min. Required WP	Type	✓	Tested to:	TVD Depth (ft) per Section:
12.25" Hole	13-5/8"	5M	Annular	✓	70% of working pressure	4321
		5M	Blind Ram	✓	250 psi / 5000 psi	
			Pipe Ram			
			Double Ram	✓		
			Other*			
9.875" Hole	13-5/8"	5M	Annular	✓	70% of working pressure	9032
		5M	Blind Ram	✓	250 psi / 5000 psi	
			Pipe Ram			
			Double Ram	✓		
			Other*			
6.75" Hole	13-5/8"	5M	Annular	✓	70% of working pressure	9735
		5M	Blind Ram	✓	250 psi / 5000 psi	
			Pipe Ram			
			Double Ram	✓		
			Other*			

*Specify if additional ram is utilized

BOP/BOPE will be tested by an independent service company to 250 psi low and the high pressure indicated above per 43 CFR part 3170 Subpart 3172 requirements. The System may be upgraded to a higher pressure but still tested to the working pressure listed in the table above. If the system is upgraded all the components installed will be functional and tested.

Pipe rams will be operationally checked each 24 hour period. Blind rams will be operationally checked on each trip out of the hole. These checks will be noted on the daily tour sheets. Other accessories to the BOP equipment will include a Kelly cock and floor safety valve (inside BOP) and choke lines and choke manifold.

	<p>Formation integrity test will be performed per 43 CFR part 3170 Subpart 3172.</p> <p>On Exploratory wells or on that portion of any well approved for a 5M BOPE system or greater, a pressure integrity test of each casing shoe shall be performed. Will be tested in accordance with 43 CFR part 3170 Subpart 3172.</p>
	<p>A variance is requested for the use of a flexible choke line from the BOP to Choke Manifold. See attached for specs and hydrostatic test chart.</p>
Y	<p>Are anchors required by manufacturer?</p>
	<p>A multibowl or a unionized multibowl wellhead system will be employed. The wellhead and connection to the BOPE will meet all API 6A requirements. The BOP will be tested per 43 CFR part 3170 Subpart 3172 after installation on the surface casing which will cover testing requirements for a maximum of 30 days. If any seal subject to test pressure is broken the system must be tested. We will test the flange connection of the wellhead with a test port that is directly in the flange. We are proposing that we will run the wellhead through the rotary prior to cementing surface casing as discussed with the BLM on October 8, 2015.</p> <p>See attached schematics.</p>

BOP Break Testing Request

Oxy requests permission to adjust the BOP break testing requirements as per the agreement reached in the OXY/BLM meeting on September 5, 2019. Please see BOP Break Testing Variance attachment for further details.

Oxy will use Cameron ADAPT wellhead system that uses an OEC top flange connection. This connection has been fully vetted and verified by API to Spec 6A and carries an API monogram.

5. Mud Program

Section	Depth		Depth - TVD		Type	Weight (ppg)	Viscosity	Water Loss
	From (ft)	To (ft)	From (ft)	To (ft)				
Surface	0	769	0	769	Water-Based Mud	8.6 - 8.8	40-60	N/C
Intermediate 1	769	4321	769	4321	Saturated Brine-Based or Oil-Based Mud	8.0 - 10.0	35-45	N/C
Intermediate 2	4321	9051	4321	9032	Water-Based or Oil-Based Mud	8.0 - 10.0	38-50	N/C
Production	9051	22644	9032	9735	Water-Based or Oil-Based Mud	8.0 - 9.6	38-50	N/C

Sufficient mud materials to maintain mud properties and meet minimum lost circulation and weight increase requirements will be kept on location at all times. The following is a general list of products: Barite, Bentonite, Gypsum, Lime, Soda Ash, Caustic Soda, Nut Plug, Cedar Fiber, Cotton Seed Hulls, Drilling Paper, Salt Water Clay, CACL2. Oxy will use a closed mud system.

What will be used to monitor the loss or gain of fluid?	PVT/MD Totco/Visual Monitoring
---	--------------------------------

6. Logging and Testing Procedures

Logging, Coring and Testing.	
Yes	Will run GR from TD to surface (horizontal well – vertical portion of hole). Stated logs run will be in the Completion Report and submitted to the BLM.
No	Logs are planned based on well control or offset log information.
No	Drill stem test? If yes, explain
No	Coring? If yes, explain
Additional logs planned	Interval
No	Resistivity
No	Density
Yes	CBL Production string
Yes	Mud log Bone Spring – TD
No	PEX

7. Drilling Conditions

Condition	Specify what type and where?
BH Pressure at deepest TVD	4860 psi
Abnormal Temperature	No
BH Temperature at deepest TVD	158°F

Pump high viscosity sweeps as needed for hole cleaning. The mud system will be monitored visually/manually as well as with an electronic PVT. The necessary mud products for additional weight and fluid loss control will be on location at all times. Appropriately weighted mud will be used to isolate potential gas, oil, and water zones until such time as casing can be cemented into place for zonal

Hydrogen Sulfide (H2S) monitors will be installed prior to drilling out the surface shoe. If H2S is detected in concentrations greater than 100 ppm, the operator will comply with the provisions of 43 CFR part 3170 Subpart 3172. If Hydrogen Sulfide is encountered, measured values and formations will be provided to the BLM.	
N	H2S is present
Y	H2S Plan attached

8. Other facets of operation

	Yes/No
Will the well be drilled with a walking/skidding operation? If yes, describe. We plan to drill the 3 well pad in batch by section: all surface sections, intermediate sections and production sections. The wellhead will be secured with a night cap whenever the rig is not over the well.	Yes
Will more than one drilling rig be used for drilling operations? If yes, describe. Oxy requests the option to contract a Surface Rig to drill, set surface casing, and cement for this well. If the timing between rigs is such that Oxy would not be able to preset surface, the Primary Rig will MIRU and drill the well in its entirety per the APD. Please see the attached document for information on the spudder rig.	Yes

Total Estimated Cuttings Volume: 1797 bbls

Revision Date – May 21, 2024

4-String Design – Open Int 1 x Int 2 Annulus

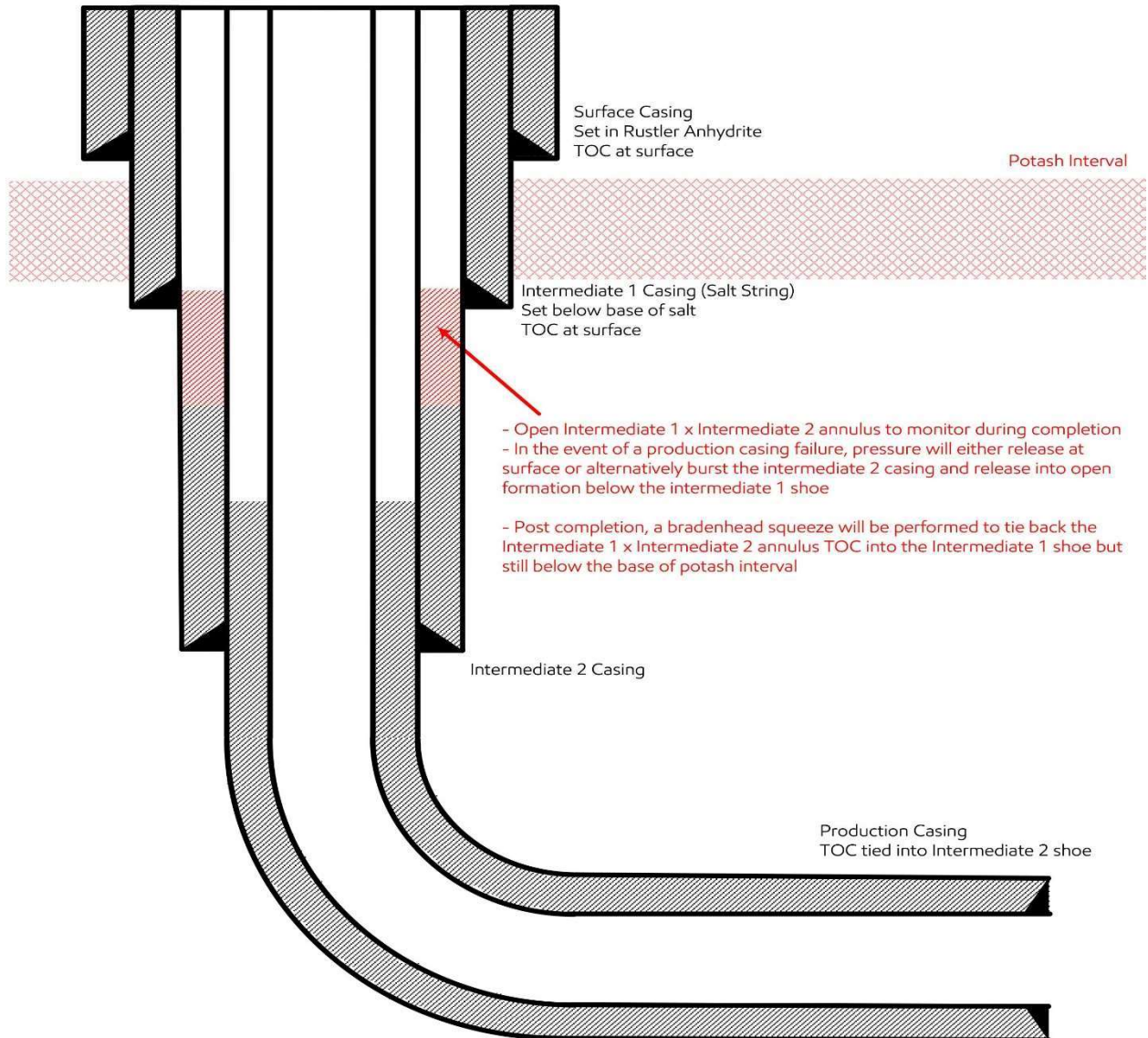
**Update May 2024:**

OXY is aware of the R111-Q update and will comply with these requirements including (but not limited to):

- 1) Alignment with KPLA requirements per schematic above, leaving open annulus for pressure monitoring during frac and utilizing new casing that meets API standards
- 2) Contingency plans in place to divert formation fluids away from salt interval in event of production casing failure
- 3) Bradenhead squeeze to be completed within 180days to tie back TOC to salt string at least 500ft but with top below Marker Bed 126
- 4) Production cement to be tied back no less than 500ft inside previous casing shoe
- 5) While drilling salt interval, separation distance to any active/inactive producing offset well will be ensured such that $SF > 1.0$; Anti-Collision Reports will be provided with APD Packages for review where $SF < 1.5$ against any applicable offset well, or where center-to-center separation against a blind or inclination only surveyed offset well is less than 500ft

Revision Date – May 21, 2024

3-String Design – Open Production Casing Annulus

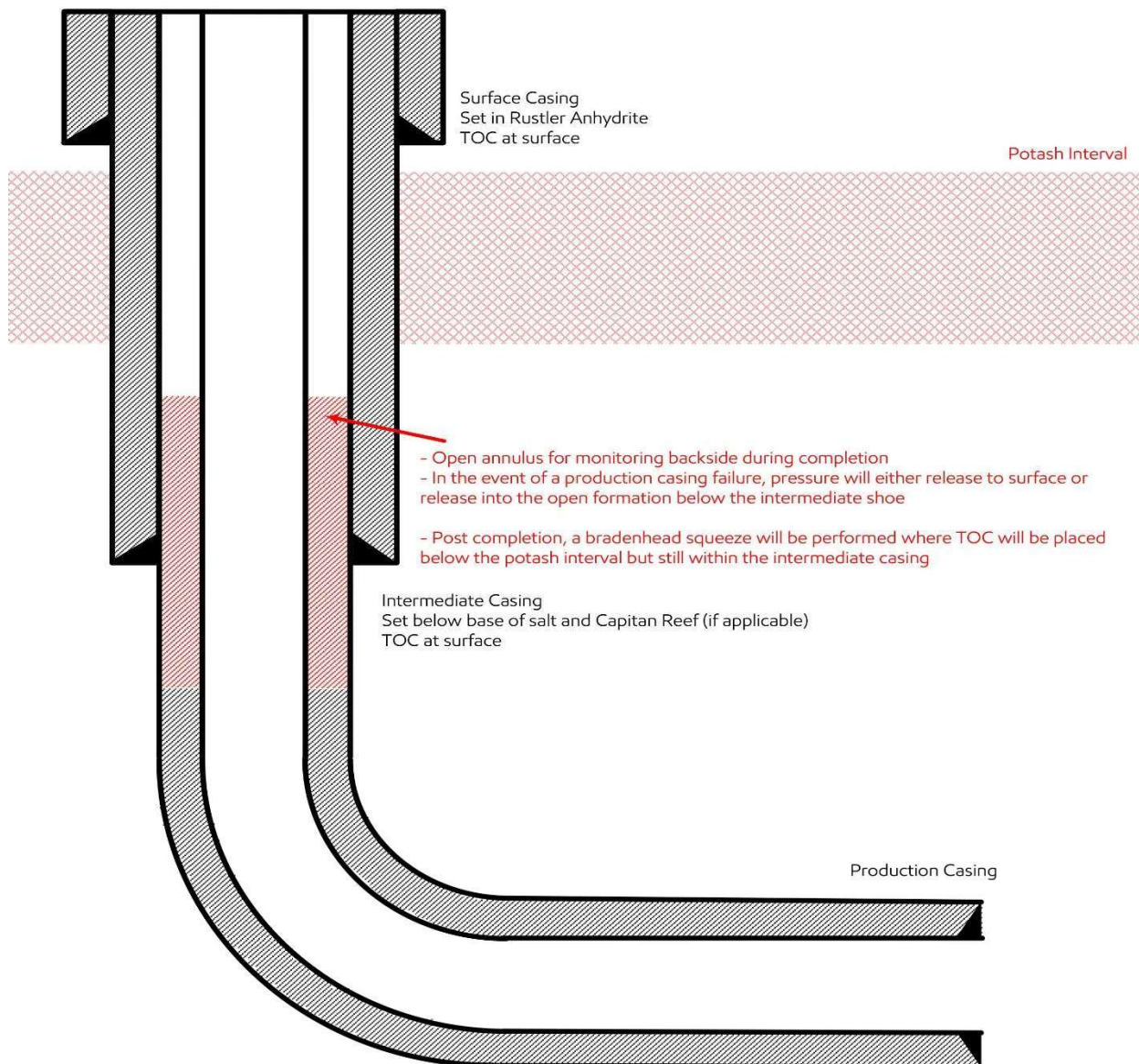

Update May 2024:

OXY is aware of the R111-Q update and will comply with these requirements including (but not limited to):

- 1) Alignment with KPLA requirements per schematic above, leaving open annulus for pressure monitoring during frac and utilizing new casing that meets API standards
- 2) Contingency plans in place to divert formation fluids away from salt interval in event of production casing failure
- 3) Bradenhead squeeze for Production cement to be completed within 180days to tie back TOC to previous casing string at least 500ft but with top below Marker Bed 126
- 4) While drilling salt interval, separation distance to any active/inactive producing offset well will be ensured such that $SF > 1.0$; Anti-Collision Reports will be provided with APD Packages for review where $SF < 1.5$ against any applicable offset well, or where center-to-center separation against a blind or inclination only surveyed offset well is less than 500ft

OXY

PRD NM DIRECTIONAL PLANS (NAD 1983)

Avid Diva 35_11 Fed Com

Avid Diva 35_11 Fed Com 4H

Wellbore #1

Plan: Permitting Plan

Standard Planning Report

11 September, 2024

OXY Planning Report

Database:	HOPSPP	Local Co-ordinate Reference:	Well Avid Diva 35_11 Fed Com 4H
Company:	ENGINEERING DESIGNS	TVD Reference:	RKB = 25' @ 3565.00ft
Project:	PRD NM DIRECTIONAL PLANS (NAD 1983)	MD Reference:	RKB = 25' @ 3565.00ft
Site:	Avid Diva 35_11 Fed Com	North Reference:	Grid
Well:	Avid Diva 35_11 Fed Com 4H	Survey Calculation Method:	Minimum Curvature
Wellbore:	Wellbore #1		
Design:	Permitting Plan		

Project PRD NM DIRECTIONAL PLANS (NAD 1983)			
Map System:	US State Plane 1983	System Datum:	Mean Sea Level
Geo Datum:	North American Datum 1983		
Map Zone:	New Mexico Eastern Zone		Using geodetic scale factor

Site Avid Diva 35_11 Fed Com			
Site Position:		Northing:	522,369.41 usft
From:	Map	Easting:	723,432.36 usft
Position Uncertainty:	0.00 ft	Slot Radius:	13.200 in
		Latitude:	32.434676
		Longitude:	-103.743111

Well Avid Diva 35_11 Fed Com 4H			
Well Position	+N/-S	0.00 ft	Northing:
	+E/-W	0.00 ft	Easting:
			522,368.41 usf
			Latitude:
			32.434673
Position Uncertainty		2.00 ft	Longitude:
			-103.743014
Grid Convergence:		0.32 °	Wellhead Elevation:
			ft
			Ground Level:
			3,540.00 ft

Wellbore Wellbore #1					
Magnetics	Model Name	Sample Date	Declination (°)	Dip Angle (°)	Field Strength (nT)
	HDGM_FILE	4/17/2024	6.40	60.05	47,581.40000000

Design Permitting Plan					
Audit Notes:					
Version:	Phase:	PROTOTYPE	Tie On Depth:	0.00	
Vertical Section:	Depth From (TVD) (ft)	+N/-S (ft)	+E/-W (ft)	Direction (°)	
	0.00	0.00	0.00	178.29	

Plan Survey Tool Program		Date 9/11/2024			
Depth From (ft)	Depth To (ft)	Survey (Wellbore)	Tool Name	Remarks	
1	0.00	22,643.26 Permitting Plan (Wellbore #1)	SQC_C705Mb_MWD+IFR1	MWD+IFR1+Sag+FDIR	

Plan Sections										
Measured Depth (ft)	Inclination (°)	Azimuth (°)	Vertical Depth (ft)	+N/-S (ft)	+E/-W (ft)	Dogleg Rate (°/100ft)	Build Rate (°/100ft)	Turn Rate (°/100ft)	TFO (°)	Target
0.00	0.00	0.00	0.00	0.00	0.00	0.00	0.00	0.00	0.00	
7,455.00	0.00	0.00	7,455.00	0.00	0.00	0.00	0.00	0.00	0.00	
8,121.72	10.00	67.46	8,118.34	22.25	53.61	1.50	1.50	0.00	67.46	
9,151.40	10.00	67.46	9,132.38	90.79	218.76	0.00	0.00	0.00	0.00	
10,089.07	90.00	179.69	9,735.00	-480.39	320.22	10.00	8.53	11.97	111.92	
22,644.07	90.00	179.69	9,735.00	-13,035.21	388.06	0.00	0.00	0.00	0.00	PBHL (Avid Diva)

OXY

Planning Report

Database:	HOPSPP	Local Co-ordinate Reference:	Well Avid Diva 35_11 Fed Com 4H
Company:	ENGINEERING DESIGNS	TVD Reference:	RKB = 25' @ 3565.00ft
Project:	PRD NM DIRECTIONAL PLANS (NAD 1983)	MD Reference:	RKB = 25' @ 3565.00ft
Site:	Avid Diva 35_11 Fed Com	North Reference:	Grid
Well:	Avid Diva 35_11 Fed Com 4H	Survey Calculation Method:	Minimum Curvature
Wellbore:	Wellbore #1		
Design:	Permitting Plan		

Planned Survey									
Measured Depth (ft)	Inclination (°)	Azimuth (°)	Vertical Depth (ft)	+N/-S (ft)	+E/-W (ft)	Vertical Section (ft)	Dogleg Rate (°/100ft)	Build Rate (°/100ft)	Turn Rate (°/100ft)
0.00	0.00	0.00	0.00	0.00	0.00	0.00	0.00	0.00	0.00
100.00	0.00	0.00	100.00	0.00	0.00	0.00	0.00	0.00	0.00
200.00	0.00	0.00	200.00	0.00	0.00	0.00	0.00	0.00	0.00
300.00	0.00	0.00	300.00	0.00	0.00	0.00	0.00	0.00	0.00
400.00	0.00	0.00	400.00	0.00	0.00	0.00	0.00	0.00	0.00
500.00	0.00	0.00	500.00	0.00	0.00	0.00	0.00	0.00	0.00
600.00	0.00	0.00	600.00	0.00	0.00	0.00	0.00	0.00	0.00
700.00	0.00	0.00	700.00	0.00	0.00	0.00	0.00	0.00	0.00
800.00	0.00	0.00	800.00	0.00	0.00	0.00	0.00	0.00	0.00
900.00	0.00	0.00	900.00	0.00	0.00	0.00	0.00	0.00	0.00
1,000.00	0.00	0.00	1,000.00	0.00	0.00	0.00	0.00	0.00	0.00
1,100.00	0.00	0.00	1,100.00	0.00	0.00	0.00	0.00	0.00	0.00
1,200.00	0.00	0.00	1,200.00	0.00	0.00	0.00	0.00	0.00	0.00
1,300.00	0.00	0.00	1,300.00	0.00	0.00	0.00	0.00	0.00	0.00
1,400.00	0.00	0.00	1,400.00	0.00	0.00	0.00	0.00	0.00	0.00
1,500.00	0.00	0.00	1,500.00	0.00	0.00	0.00	0.00	0.00	0.00
1,600.00	0.00	0.00	1,600.00	0.00	0.00	0.00	0.00	0.00	0.00
1,700.00	0.00	0.00	1,700.00	0.00	0.00	0.00	0.00	0.00	0.00
1,800.00	0.00	0.00	1,800.00	0.00	0.00	0.00	0.00	0.00	0.00
1,900.00	0.00	0.00	1,900.00	0.00	0.00	0.00	0.00	0.00	0.00
2,000.00	0.00	0.00	2,000.00	0.00	0.00	0.00	0.00	0.00	0.00
2,100.00	0.00	0.00	2,100.00	0.00	0.00	0.00	0.00	0.00	0.00
2,200.00	0.00	0.00	2,200.00	0.00	0.00	0.00	0.00	0.00	0.00
2,300.00	0.00	0.00	2,300.00	0.00	0.00	0.00	0.00	0.00	0.00
2,400.00	0.00	0.00	2,400.00	0.00	0.00	0.00	0.00	0.00	0.00
2,500.00	0.00	0.00	2,500.00	0.00	0.00	0.00	0.00	0.00	0.00
2,600.00	0.00	0.00	2,600.00	0.00	0.00	0.00	0.00	0.00	0.00
2,700.00	0.00	0.00	2,700.00	0.00	0.00	0.00	0.00	0.00	0.00
2,800.00	0.00	0.00	2,800.00	0.00	0.00	0.00	0.00	0.00	0.00
2,900.00	0.00	0.00	2,900.00	0.00	0.00	0.00	0.00	0.00	0.00
3,000.00	0.00	0.00	3,000.00	0.00	0.00	0.00	0.00	0.00	0.00
3,100.00	0.00	0.00	3,100.00	0.00	0.00	0.00	0.00	0.00	0.00
3,200.00	0.00	0.00	3,200.00	0.00	0.00	0.00	0.00	0.00	0.00
3,300.00	0.00	0.00	3,300.00	0.00	0.00	0.00	0.00	0.00	0.00
3,400.00	0.00	0.00	3,400.00	0.00	0.00	0.00	0.00	0.00	0.00
3,500.00	0.00	0.00	3,500.00	0.00	0.00	0.00	0.00	0.00	0.00
3,600.00	0.00	0.00	3,600.00	0.00	0.00	0.00	0.00	0.00	0.00
3,700.00	0.00	0.00	3,700.00	0.00	0.00	0.00	0.00	0.00	0.00
3,800.00	0.00	0.00	3,800.00	0.00	0.00	0.00	0.00	0.00	0.00
3,900.00	0.00	0.00	3,900.00	0.00	0.00	0.00	0.00	0.00	0.00
4,000.00	0.00	0.00	4,000.00	0.00	0.00	0.00	0.00	0.00	0.00
4,100.00	0.00	0.00	4,100.00	0.00	0.00	0.00	0.00	0.00	0.00
4,200.00	0.00	0.00	4,200.00	0.00	0.00	0.00	0.00	0.00	0.00
4,300.00	0.00	0.00	4,300.00	0.00	0.00	0.00	0.00	0.00	0.00
4,400.00	0.00	0.00	4,400.00	0.00	0.00	0.00	0.00	0.00	0.00
4,500.00	0.00	0.00	4,500.00	0.00	0.00	0.00	0.00	0.00	0.00
4,600.00	0.00	0.00	4,600.00	0.00	0.00	0.00	0.00	0.00	0.00
4,700.00	0.00	0.00	4,700.00	0.00	0.00	0.00	0.00	0.00	0.00
4,800.00	0.00	0.00	4,800.00	0.00	0.00	0.00	0.00	0.00	0.00
4,900.00	0.00	0.00	4,900.00	0.00	0.00	0.00	0.00	0.00	0.00
5,000.00	0.00	0.00	5,000.00	0.00	0.00	0.00	0.00	0.00	0.00
5,100.00	0.00	0.00	5,100.00	0.00	0.00	0.00	0.00	0.00	0.00
5,200.00	0.00	0.00	5,200.00	0.00	0.00	0.00	0.00	0.00	0.00
5,300.00	0.00	0.00	5,300.00	0.00	0.00	0.00	0.00	0.00	0.00
5,400.00	0.00	0.00	5,400.00	0.00	0.00	0.00	0.00	0.00	0.00

OXY
Planning Report

Database:	HOPSPP	Local Co-ordinate Reference:	Well Avid Diva 35_11 Fed Com 4H
Company:	ENGINEERING DESIGNS	TVD Reference:	RKB = 25' @ 3565.00ft
Project:	PRD NM DIRECTIONAL PLANS (NAD 1983)	MD Reference:	RKB = 25' @ 3565.00ft
Site:	Avid Diva 35_11 Fed Com	North Reference:	Grid
Well:	Avid Diva 35_11 Fed Com 4H	Survey Calculation Method:	Minimum Curvature
Wellbore:	Wellbore #1		
Design:	Permitting Plan		

Planned Survey									
Measured Depth (ft)	Inclination (°)	Azimuth (°)	Vertical Depth (ft)	+N/-S (ft)	+E/-W (ft)	Vertical Section (ft)	Dogleg Rate (°/100ft)	Build Rate (°/100ft)	Turn Rate (°/100ft)
5,500.00	0.00	0.00	5,500.00	0.00	0.00	0.00	0.00	0.00	0.00
5,600.00	0.00	0.00	5,600.00	0.00	0.00	0.00	0.00	0.00	0.00
5,700.00	0.00	0.00	5,700.00	0.00	0.00	0.00	0.00	0.00	0.00
5,800.00	0.00	0.00	5,800.00	0.00	0.00	0.00	0.00	0.00	0.00
5,900.00	0.00	0.00	5,900.00	0.00	0.00	0.00	0.00	0.00	0.00
6,000.00	0.00	0.00	6,000.00	0.00	0.00	0.00	0.00	0.00	0.00
6,100.00	0.00	0.00	6,100.00	0.00	0.00	0.00	0.00	0.00	0.00
6,200.00	0.00	0.00	6,200.00	0.00	0.00	0.00	0.00	0.00	0.00
6,300.00	0.00	0.00	6,300.00	0.00	0.00	0.00	0.00	0.00	0.00
6,400.00	0.00	0.00	6,400.00	0.00	0.00	0.00	0.00	0.00	0.00
6,500.00	0.00	0.00	6,500.00	0.00	0.00	0.00	0.00	0.00	0.00
6,600.00	0.00	0.00	6,600.00	0.00	0.00	0.00	0.00	0.00	0.00
6,700.00	0.00	0.00	6,700.00	0.00	0.00	0.00	0.00	0.00	0.00
6,800.00	0.00	0.00	6,800.00	0.00	0.00	0.00	0.00	0.00	0.00
6,900.00	0.00	0.00	6,900.00	0.00	0.00	0.00	0.00	0.00	0.00
7,000.00	0.00	0.00	7,000.00	0.00	0.00	0.00	0.00	0.00	0.00
7,100.00	0.00	0.00	7,100.00	0.00	0.00	0.00	0.00	0.00	0.00
7,200.00	0.00	0.00	7,200.00	0.00	0.00	0.00	0.00	0.00	0.00
7,300.00	0.00	0.00	7,300.00	0.00	0.00	0.00	0.00	0.00	0.00
7,400.00	0.00	0.00	7,400.00	0.00	0.00	0.00	0.00	0.00	0.00
7,455.00	0.00	0.00	7,455.00	0.00	0.00	0.00	0.00	0.00	0.00
7,500.00	0.68	67.46	7,500.00	0.10	0.24	-0.09	1.50	1.50	0.00
7,600.00	2.18	67.46	7,599.97	1.05	2.54	-0.98	1.50	1.50	0.00
7,700.00	3.68	67.46	7,699.83	3.01	7.25	-2.79	1.50	1.50	0.00
7,800.00	5.18	67.46	7,799.53	5.97	14.38	-5.54	1.50	1.50	0.00
7,900.00	6.68	67.46	7,898.99	9.92	23.91	-9.21	1.50	1.50	0.00
8,000.00	8.18	67.46	7,998.15	14.88	35.85	-13.80	1.50	1.50	0.00
8,100.00	9.68	67.46	8,096.94	20.82	50.18	-19.32	1.50	1.50	0.00
8,121.72	10.00	67.46	8,118.34	22.25	53.61	-20.64	1.50	1.50	0.00
8,200.00	10.00	67.46	8,195.43	27.46	66.16	-25.48	0.00	0.00	0.00
8,300.00	10.00	67.46	8,293.91	34.12	82.20	-31.65	0.00	0.00	0.00
8,400.00	10.00	67.46	8,392.39	40.77	98.24	-37.83	0.00	0.00	0.00
8,500.00	10.00	67.46	8,490.87	47.43	114.28	-44.01	0.00	0.00	0.00
8,600.00	10.00	67.46	8,589.35	54.09	130.32	-50.18	0.00	0.00	0.00
8,700.00	10.00	67.46	8,687.83	60.74	146.36	-56.36	0.00	0.00	0.00
8,800.00	10.00	67.46	8,786.31	67.40	162.40	-62.54	0.00	0.00	0.00
8,900.00	10.00	67.46	8,884.79	74.06	178.44	-68.71	0.00	0.00	0.00
9,000.00	10.00	67.46	8,983.27	80.71	194.48	-74.89	0.00	0.00	0.00
9,100.00	10.00	67.46	9,081.76	87.37	210.52	-81.07	0.00	0.00	0.00
9,151.40	10.00	67.46	9,132.38	90.79	218.76	-84.24	0.00	0.00	0.00
9,200.00	9.33	96.44	9,180.31	91.97	226.58	-85.18	10.00	-1.37	59.64
9,300.00	14.42	140.28	9,278.32	81.45	242.64	-74.20	10.00	5.09	43.84
9,400.00	22.96	157.02	9,373.03	53.85	258.25	-46.14	10.00	8.54	16.74
9,500.00	32.31	164.73	9,461.55	10.00	272.93	-1.88	10.00	9.36	7.71
9,600.00	41.94	169.22	9,541.20	-48.76	286.25	57.26	10.00	9.63	4.49
9,700.00	51.69	172.28	9,609.56	-120.65	297.80	129.46	10.00	9.75	3.06
9,800.00	61.51	174.61	9,664.54	-203.49	307.22	212.54	10.00	9.81	2.32
9,900.00	71.35	176.53	9,704.49	-294.76	314.24	303.98	10.00	9.84	1.93
10,000.00	81.21	178.24	9,728.18	-391.68	318.63	400.99	10.00	9.86	1.71
10,089.07	90.00	179.69	9,735.00	-480.39	320.22	489.71	10.00	9.87	1.62
10,100.00	90.00	179.69	9,735.00	-491.32	320.28	500.63	0.00	0.00	0.00
10,200.00	90.00	179.69	9,735.00	-591.32	320.82	600.60	0.00	0.00	0.00
10,300.00	90.00	179.69	9,735.00	-691.31	321.36	700.57	0.00	0.00	0.00
10,400.00	90.00	179.69	9,735.00	-791.31	321.90	800.54	0.00	0.00	0.00
10,500.00	90.00	179.69	9,735.00	-891.31	322.44	900.51	0.00	0.00	0.00

OXY Planning Report

Database:	HOPSPP	Local Co-ordinate Reference:	Well Avid Diva 35_11 Fed Com 4H
Company:	ENGINEERING DESIGNS	TVD Reference:	RKB = 25' @ 3565.00ft
Project:	PRD NM DIRECTIONAL PLANS (NAD 1983)	MD Reference:	RKB = 25' @ 3565.00ft
Site:	Avid Diva 35_11 Fed Com	North Reference:	Grid
Well:	Avid Diva 35_11 Fed Com 4H	Survey Calculation Method:	Minimum Curvature
Wellbore:	Wellbore #1		
Design:	Permitting Plan		

Planned Survey										
Measured Depth (ft)	Inclination (°)	Azimuth (°)	Vertical Depth (ft)	+N/-S (ft)	+E/-W (ft)	Vertical Section (ft)	Dogleg Rate (°/100ft)	Build Rate (°/100ft)	Turn Rate (°/100ft)	
10,600.00	90.00	179.69	9,735.00	-991.31	322.98	1,000.48	0.00	0.00	0.00	
10,700.00	90.00	179.69	9,735.00	-1,091.31	323.52	1,100.45	0.00	0.00	0.00	
10,800.00	90.00	179.69	9,735.00	-1,191.31	324.06	1,200.42	0.00	0.00	0.00	
10,900.00	90.00	179.69	9,735.00	-1,291.31	324.60	1,300.39	0.00	0.00	0.00	
11,000.00	90.00	179.69	9,735.00	-1,391.30	325.14	1,400.36	0.00	0.00	0.00	
11,100.00	90.00	179.69	9,735.00	-1,491.30	325.68	1,500.33	0.00	0.00	0.00	
11,200.00	90.00	179.69	9,735.00	-1,591.30	326.22	1,600.30	0.00	0.00	0.00	
11,300.00	90.00	179.69	9,735.00	-1,691.30	326.76	1,700.27	0.00	0.00	0.00	
11,400.00	90.00	179.69	9,735.00	-1,791.30	327.30	1,800.25	0.00	0.00	0.00	
11,500.00	90.00	179.69	9,735.00	-1,891.30	327.85	1,900.22	0.00	0.00	0.00	
11,600.00	90.00	179.69	9,735.00	-1,991.30	328.39	2,000.19	0.00	0.00	0.00	
11,700.00	90.00	179.69	9,735.00	-2,091.29	328.93	2,100.16	0.00	0.00	0.00	
11,800.00	90.00	179.69	9,735.00	-2,191.29	329.47	2,200.13	0.00	0.00	0.00	
11,900.00	90.00	179.69	9,735.00	-2,291.29	330.01	2,300.10	0.00	0.00	0.00	
12,000.00	90.00	179.69	9,735.00	-2,391.29	330.55	2,400.07	0.00	0.00	0.00	
12,100.00	90.00	179.69	9,735.00	-2,491.29	331.09	2,500.04	0.00	0.00	0.00	
12,200.00	90.00	179.69	9,735.00	-2,591.29	331.63	2,600.01	0.00	0.00	0.00	
12,300.00	90.00	179.69	9,735.00	-2,691.29	332.17	2,699.98	0.00	0.00	0.00	
12,400.00	90.00	179.69	9,735.00	-2,791.28	332.71	2,799.95	0.00	0.00	0.00	
12,500.00	90.00	179.69	9,735.00	-2,891.28	333.25	2,899.92	0.00	0.00	0.00	
12,600.00	90.00	179.69	9,735.00	-2,991.28	333.79	2,999.89	0.00	0.00	0.00	
12,700.00	90.00	179.69	9,735.00	-3,091.28	334.33	3,099.86	0.00	0.00	0.00	
12,800.00	90.00	179.69	9,735.00	-3,191.28	334.87	3,199.83	0.00	0.00	0.00	
12,900.00	90.00	179.69	9,735.00	-3,291.28	335.41	3,299.80	0.00	0.00	0.00	
13,000.00	90.00	179.69	9,735.00	-3,391.28	335.95	3,399.77	0.00	0.00	0.00	
13,100.00	90.00	179.69	9,735.00	-3,491.27	336.49	3,499.74	0.00	0.00	0.00	
13,200.00	90.00	179.69	9,735.00	-3,591.27	337.03	3,599.71	0.00	0.00	0.00	
13,300.00	90.00	179.69	9,735.00	-3,691.27	337.57	3,699.68	0.00	0.00	0.00	
13,400.00	90.00	179.69	9,735.00	-3,791.27	338.11	3,799.65	0.00	0.00	0.00	
13,500.00	90.00	179.69	9,735.00	-3,891.27	338.65	3,899.62	0.00	0.00	0.00	
13,600.00	90.00	179.69	9,735.00	-3,991.27	339.19	3,999.59	0.00	0.00	0.00	
13,700.00	90.00	179.69	9,735.00	-4,091.27	339.73	4,099.56	0.00	0.00	0.00	
13,800.00	90.00	179.69	9,735.00	-4,191.26	340.27	4,199.53	0.00	0.00	0.00	
13,900.00	90.00	179.69	9,735.00	-4,291.26	340.81	4,299.50	0.00	0.00	0.00	
14,000.00	90.00	179.69	9,735.00	-4,391.26	341.35	4,399.47	0.00	0.00	0.00	
14,100.00	90.00	179.69	9,735.00	-4,491.26	341.89	4,499.44	0.00	0.00	0.00	
14,200.00	90.00	179.69	9,735.00	-4,591.26	342.43	4,599.41	0.00	0.00	0.00	
14,300.00	90.00	179.69	9,735.00	-4,691.26	342.97	4,699.39	0.00	0.00	0.00	
14,400.00	90.00	179.69	9,735.00	-4,791.26	343.51	4,799.36	0.00	0.00	0.00	
14,500.00	90.00	179.69	9,735.00	-4,891.25	344.06	4,899.33	0.00	0.00	0.00	
14,600.00	90.00	179.69	9,735.00	-4,991.25	344.60	4,999.30	0.00	0.00	0.00	
14,700.00	90.00	179.69	9,735.00	-5,091.25	345.14	5,099.27	0.00	0.00	0.00	
14,800.00	90.00	179.69	9,735.00	-5,191.25	345.68	5,199.24	0.00	0.00	0.00	
14,900.00	90.00	179.69	9,735.00	-5,291.25	346.22	5,299.21	0.00	0.00	0.00	
15,000.00	90.00	179.69	9,735.00	-5,391.25	346.76	5,399.18	0.00	0.00	0.00	
15,100.00	90.00	179.69	9,735.00	-5,491.24	347.30	5,499.15	0.00	0.00	0.00	
15,200.00	90.00	179.69	9,735.00	-5,591.24	347.84	5,599.12	0.00	0.00	0.00	
15,300.00	90.00	179.69	9,735.00	-5,691.24	348.38	5,699.09	0.00	0.00	0.00	
15,400.00	90.00	179.69	9,735.00	-5,791.24	348.92	5,799.06	0.00	0.00	0.00	
15,500.00	90.00	179.69	9,735.00	-5,891.24	349.46	5,899.03	0.00	0.00	0.00	
15,600.00	90.00	179.69	9,735.00	-5,991.24	350.00	5,999.00	0.00	0.00	0.00	
15,700.00	90.00	179.69	9,735.00	-6,091.24	350.54	6,098.97	0.00	0.00	0.00	
15,800.00	90.00	179.69	9,735.00	-6,191.23	351.08	6,198.94	0.00	0.00	0.00	
15,900.00	90.00	179.69	9,735.00	-6,291.23	351.62	6,298.91	0.00	0.00	0.00	
16,000.00	90.00	179.69	9,735.00	-6,391.23	352.16	6,398.88	0.00	0.00	0.00	

OXY Planning Report

Database:	HOSPSP	Local Co-ordinate Reference:	Well Avid Diva 35_11 Fed Com 4H
Company:	ENGINEERING DESIGNS	TVD Reference:	RKB = 25' @ 3565.00ft
Project:	PRD NM DIRECTIONAL PLANS (NAD 1983)	MD Reference:	RKB = 25' @ 3565.00ft
Site:	Avid Diva 35_11 Fed Com	North Reference:	Grid
Well:	Avid Diva 35_11 Fed Com 4H	Survey Calculation Method:	Minimum Curvature
Wellbore:	Wellbore #1		
Design:	Permitting Plan		

Planned Survey									
Measured Depth (ft)	Inclination (°)	Azimuth (°)	Vertical Depth (ft)	+N/-S (ft)	+E/-W (ft)	Vertical Section (ft)	Dogleg Rate (°/100ft)	Build Rate (°/100ft)	Turn Rate (°/100ft)
16,100.00	90.00	179.69	9,735.00	-6,491.23	352.70	6,498.85	0.00	0.00	0.00
16,200.00	90.00	179.69	9,735.00	-6,591.23	353.24	6,598.82	0.00	0.00	0.00
16,300.00	90.00	179.69	9,735.00	-6,691.23	353.78	6,698.79	0.00	0.00	0.00
16,400.00	90.00	179.69	9,735.00	-6,791.23	354.32	6,798.76	0.00	0.00	0.00
16,500.00	90.00	179.69	9,735.00	-6,891.22	354.86	6,898.73	0.00	0.00	0.00
16,600.00	90.00	179.69	9,735.00	-6,991.22	355.40	6,998.70	0.00	0.00	0.00
16,700.00	90.00	179.69	9,735.00	-7,091.22	355.94	7,098.67	0.00	0.00	0.00
16,800.00	90.00	179.69	9,735.00	-7,191.22	356.48	7,198.64	0.00	0.00	0.00
16,900.00	90.00	179.69	9,735.00	-7,291.22	357.02	7,298.61	0.00	0.00	0.00
17,000.00	90.00	179.69	9,735.00	-7,391.22	357.56	7,398.58	0.00	0.00	0.00
17,100.00	90.00	179.69	9,735.00	-7,491.22	358.10	7,498.55	0.00	0.00	0.00
17,200.00	90.00	179.69	9,735.00	-7,591.21	358.64	7,598.52	0.00	0.00	0.00
17,300.00	90.00	179.69	9,735.00	-7,691.21	359.18	7,698.50	0.00	0.00	0.00
17,400.00	90.00	179.69	9,735.00	-7,791.21	359.73	7,798.47	0.00	0.00	0.00
17,500.00	90.00	179.69	9,735.00	-7,891.21	360.27	7,898.44	0.00	0.00	0.00
17,600.00	90.00	179.69	9,735.00	-7,991.21	360.81	7,998.41	0.00	0.00	0.00
17,700.00	90.00	179.69	9,735.00	-8,091.21	361.35	8,098.38	0.00	0.00	0.00
17,800.00	90.00	179.69	9,735.00	-8,191.21	361.89	8,198.35	0.00	0.00	0.00
17,900.00	90.00	179.69	9,735.00	-8,291.20	362.43	8,298.32	0.00	0.00	0.00
18,000.00	90.00	179.69	9,735.00	-8,391.20	362.97	8,398.29	0.00	0.00	0.00
18,100.00	90.00	179.69	9,735.00	-8,491.20	363.51	8,498.26	0.00	0.00	0.00
18,200.00	90.00	179.69	9,735.00	-8,591.20	364.05	8,598.23	0.00	0.00	0.00
18,300.00	90.00	179.69	9,735.00	-8,691.20	364.59	8,698.20	0.00	0.00	0.00
18,400.00	90.00	179.69	9,735.00	-8,791.20	365.13	8,798.17	0.00	0.00	0.00
18,500.00	90.00	179.69	9,735.00	-8,891.20	365.67	8,898.14	0.00	0.00	0.00
18,600.00	90.00	179.69	9,735.00	-8,991.19	366.21	8,998.11	0.00	0.00	0.00
18,700.00	90.00	179.69	9,735.00	-9,091.19	366.75	9,098.08	0.00	0.00	0.00
18,800.00	90.00	179.69	9,735.00	-9,191.19	367.29	9,198.05	0.00	0.00	0.00
18,900.00	90.00	179.69	9,735.00	-9,291.19	367.83	9,298.02	0.00	0.00	0.00
19,000.00	90.00	179.69	9,735.00	-9,391.19	368.37	9,397.99	0.00	0.00	0.00
19,100.00	90.00	179.69	9,735.00	-9,491.19	368.91	9,497.96	0.00	0.00	0.00
19,200.00	90.00	179.69	9,735.00	-9,591.19	369.45	9,597.93	0.00	0.00	0.00
19,300.00	90.00	179.69	9,735.00	-9,691.18	369.99	9,697.90	0.00	0.00	0.00
19,400.00	90.00	179.69	9,735.00	-9,791.18	370.53	9,797.87	0.00	0.00	0.00
19,500.00	90.00	179.69	9,735.00	-9,891.18	371.07	9,897.84	0.00	0.00	0.00
19,600.00	90.00	179.69	9,735.00	-9,991.18	371.61	9,997.81	0.00	0.00	0.00
19,700.00	90.00	179.69	9,735.00	-10,091.18	372.15	10,097.78	0.00	0.00	0.00
19,800.00	90.00	179.69	9,735.00	-10,191.18	372.69	10,197.75	0.00	0.00	0.00
19,900.00	90.00	179.69	9,735.00	-10,291.17	373.23	10,297.72	0.00	0.00	0.00
20,000.00	90.00	179.69	9,735.00	-10,391.17	373.77	10,397.69	0.00	0.00	0.00
20,100.00	90.00	179.69	9,735.00	-10,491.17	374.31	10,497.66	0.00	0.00	0.00
20,200.00	90.00	179.69	9,735.00	-10,591.17	374.85	10,597.64	0.00	0.00	0.00
20,300.00	90.00	179.69	9,735.00	-10,691.17	375.40	10,697.61	0.00	0.00	0.00
20,400.00	90.00	179.69	9,735.00	-10,791.17	375.94	10,797.58	0.00	0.00	0.00
20,500.00	90.00	179.69	9,735.00	-10,891.17	376.48	10,897.55	0.00	0.00	0.00
20,600.00	90.00	179.69	9,735.00	-10,991.16	377.02	10,997.52	0.00	0.00	0.00
20,700.00	90.00	179.69	9,735.00	-11,091.16	377.56	11,097.49	0.00	0.00	0.00
20,800.00	90.00	179.69	9,735.00	-11,191.16	378.10	11,197.46	0.00	0.00	0.00
20,900.00	90.00	179.69	9,735.00	-11,291.16	378.64	11,297.43	0.00	0.00	0.00
21,000.00	90.00	179.69	9,735.00	-11,391.16	379.18	11,397.40	0.00	0.00	0.00
21,100.00	90.00	179.69	9,735.00	-11,491.16	379.72	11,497.37	0.00	0.00	0.00
21,200.00	90.00	179.69	9,735.00	-11,591.16	380.26	11,597.34	0.00	0.00	0.00
21,300.00	90.00	179.69	9,735.00	-11,691.15	380.80	11,697.31	0.00	0.00	0.00
21,400.00	90.00	179.69	9,735.00	-11,791.15	381.34	11,797.28	0.00	0.00	0.00
21,500.00	90.00	179.69	9,735.00	-11,891.15	381.88	11,897.25	0.00	0.00	0.00

OXY Planning Report

Database:	HOPSPP	Local Co-ordinate Reference:	Well Avid Diva 35_11 Fed Com 4H
Company:	ENGINEERING DESIGNS	TVD Reference:	RKB = 25' @ 3565.00ft
Project:	PRD NM DIRECTIONAL PLANS (NAD 1983)	MD Reference:	RKB = 25' @ 3565.00ft
Site:	Avid Diva 35_11 Fed Com	North Reference:	Grid
Well:	Avid Diva 35_11 Fed Com 4H	Survey Calculation Method:	Minimum Curvature
Wellbore:	Wellbore #1		
Design:	Permitting Plan		

Planned Survey									
Measured Depth (ft)	Inclination (°)	Azimuth (°)	Vertical Depth (ft)	+N/-S (ft)	+E/-W (ft)	Vertical Section (ft)	Dogleg Rate (°/100ft)	Build Rate (°/100ft)	Turn Rate (°/100ft)
21,600.00	90.00	179.69	9,735.00	-11,991.15	382.42	11,997.22	0.00	0.00	0.00
21,700.00	90.00	179.69	9,735.00	-12,091.15	382.96	12,097.19	0.00	0.00	0.00
21,800.00	90.00	179.69	9,735.00	-12,191.15	383.50	12,197.16	0.00	0.00	0.00
21,900.00	90.00	179.69	9,735.00	-12,291.15	384.04	12,297.13	0.00	0.00	0.00
22,000.00	90.00	179.69	9,735.00	-12,391.14	384.58	12,397.10	0.00	0.00	0.00
22,100.00	90.00	179.69	9,735.00	-12,491.14	385.12	12,497.07	0.00	0.00	0.00
22,200.00	90.00	179.69	9,735.00	-12,591.14	385.66	12,597.04	0.00	0.00	0.00
22,300.00	90.00	179.69	9,735.00	-12,691.14	386.20	12,697.01	0.00	0.00	0.00
22,400.00	90.00	179.69	9,735.00	-12,791.14	386.74	12,796.98	0.00	0.00	0.00
22,500.00	90.00	179.69	9,735.00	-12,891.14	387.28	12,896.95	0.00	0.00	0.00
22,600.00	90.00	179.69	9,735.00	-12,991.14	387.82	12,996.92	0.00	0.00	0.00
22,644.07	90.00	179.69	9,735.00	-13,035.21	388.06	13,040.98	0.00	0.00	0.00

Design Targets									
Target Name - hit/miss target - Shape	Dip Angle (°)	Dip Dir. (°)	TVD (ft)	+N/-S (ft)	+E/-W (ft)	Northing (usft)	Easting (usft)	Latitude	Longitude
KOP (Avid Diva 35_11 - plan misses target center by 330.23ft at 0.00ft MD (0.00 TVD, 0.00 N, 0.00 E) - Point	0.00	0.00	0.00	92.19	317.10	522,460.59	723,779.46	32.434922	-103.741985
FTP (Avid Diva 35_11 - plan misses target center by 202.62ft at 9670.87ft MD (9590.94 TVD, -98.48 N, 294.64 E) - Point	0.00	0.00	9,735.00	42.18	317.40	522,410.59	723,779.76	32.434784	-103.741984
PBHL (Avid Diva - plan hits target center - Point	0.00	0.00	9,735.00	-13,035.21	388.06	509,333.92	723,850.42	32.398840	-103.741990

Formations					
Measured Depth (ft)	Vertical Depth (ft)	Name	Lithology	Dip (°)	Dip Direction (°)
709.00	709.00	RUSTLER			
1,011.00	1,011.00	SALADO			
2,621.00	2,621.00	CASTILE			
4,321.00	4,321.00	DELAWARE			
4,425.00	4,425.00	BELL CANYON			
5,244.00	5,244.00	CHERRY CANYON			
6,548.00	6,548.00	BRUSHY CANYON			
8,281.81	8,276.00	BONE SPRING			
9,374.12	9,349.00	BONE SPRING 1ST			

OXY
Planning Report

Database:	HOPSPP	Local Co-ordinate Reference:	Well Avid Diva 35_11 Fed Com 4H
Company:	ENGINEERING DESIGNS	TVD Reference:	RKB = 25' @ 3565.00ft
Project:	PRD NM DIRECTIONAL PLANS (NAD 1983)	MD Reference:	RKB = 25' @ 3565.00ft
Site:	Avid Diva 35_11 Fed Com	North Reference:	Grid
Well:	Avid Diva 35_11 Fed Com 4H	Survey Calculation Method:	Minimum Curvature
Wellbore:	Wellbore #1		
Design:	Permitting Plan		

Plan Annotations					
Measured Depth (ft)	Vertical Depth (ft)	Local Coordinates			
		+N/-S (ft)	+E/-W (ft)		Comment
7,455.00	7,455.00	0.00	0.00		Build 1.5°/100'
8,121.72	8,118.34	22.25	53.61		Hold 10° Tangent
9,151.40	9,132.38	90.79	218.76		KOP, Build & Turn 10°/100'
10,089.07	9,735.00	-480.39	320.22		Landing Point
22,644.07	9,735.00	-13,035.21	388.06		TD at 22644.07' MD

PECOS DISTRICT DRILLING CONDITIONS OF APPROVAL

OPERATOR'S NAME: OXY USA INC.
WELL NAME & NO.: AVID DIVA 35 11 FEDERAL COM 4H
LOCATION: Sec 35, T21S, R31E
COUNTY: Eddy County, New Mexico ▼

COA

H ₂ S	○ No		● Yes	
Potash / WIPP	○ None	○ Secretary	● R-111-Q	☑ Open Annulus
	4-String Design: Open 1st Int x 2nd Annulus (ICP 2 below Relief Zone)			☐ WIPP
Cave / Karst	● Low	○ Medium	○ High	○ Critical
Wellhead	○ Conventional	● Multibowl	○ Both	○ Diverter
Cementing	☑ Primary Squeeze	☐ Cont. Squeeze	☑ EchoMeter	☐ DV Tool
Special Req	☐ Capitan Reef	☐ Water Disposal	☑ COM	☐ Unit
Waste Prev.	○ Self-Certification	● Waste Min. Plan	○ APD Submitted prior to 06/10/2024	
Additional Language	☑ Flex Hose	☑ Casing Clearance	☐ Pilot Hole	☑ Break Testing
	☑ Four-String	☑ Offline Cementing	☐ Fluid-Filled	

A. HYDROGEN SULFIDE

A Hydrogen Sulfide (H₂S) Drilling Plan shall be activated AT SPUD. As a result, the Hydrogen Sulfide area must meet all requirements from 43 CFR 3176, which includes equipment and personnel/public protection items. If Hydrogen Sulfide is encountered, please provide measured values and formations to the BLM.

APD is within the R-111-Q defined boundary. Operator must follow all procedures and requirements listed within the updated order.

B. CASING

Set points in COA reflects requirements from BLM Geology. Please review.

1. The 13-3/8 inch surface casing shall be set at approximately **769** feet (a minimum of 70 feet (Eddy County) into the Rustler Anhydrite, above the salt, and below usable fresh water) and cemented to the surface.
 - a. If cement does not circulate to the surface, the appropriate BLM office shall be notified and a temperature survey utilizing an electronic type temperature survey with surface log readout will be used or a cement bond log shall be run to verify the top of the cement. Temperature survey will be run a minimum of six hours after pumping

- cement and ideally between 8-10 hours after completing the cement job.
- b. Wait on cement (WOC) time for a primary cement job will be a minimum of **8 hours** or **500 pounds compressive strength**, whichever is greater. (This is to include the lead cement)
 - c. Wait on cement (WOC) time for a remedial job will be a minimum of 4 hours after bringing cement to surface or 500 pounds compressive strength, whichever is greater.
 - d. If cement falls back, remedial cementing will be done prior to drilling out that string.
2. The **10-3/4** inch intermediate salt protection casing shall be set at approximately **4271** feet **TVD. Please set Salt Protection string prior to entering hydrocarbon bearing zone (Delaware)**. The minimum required fill of cement behind the **10-3/4** inch intermediate casing is:
- Cement to surface. If cement does not circulate see B.1.a, c-d above. **Wait on cement (WOC) time for a primary cement job is to include the lead cement slurry due to cave/karst, Capitan Reef, or potash.**
3. The **7-5/8** inch second intermediate casing shall be set at approximately **9051** feet. **PLEASE REVIEW EXTERNAL PRESSURE FOR PRESSURE TEST. PLEASE KEEP CASING FULL FOR COLLAPSE SF.** The minimum required fill of cement behind the **7-5/8** inch intermediate casing is:

Option 1 (Primary + Post Frac Bradenhead):

- Cement should tie-back **500 feet** into the previous casing but not higher than USGS Marker Bed No. 126. **Operator must verify top of cement per R-111-Q requirements.** Submit results to the BLM. If cement does not circulate, contact the appropriate BLM office. **Wait on cement (WOC) time for a primary cement job is to include the lead cement slurry due to cave/karst, Capitan Reef, or potash.**
- ❖ **A monitored open annulus will be incorporated during completion by leaving the Intermediate Casing 1 x Intermediate Casing 2 annulus un-cemented and monitored inside the Intermediate String.** Operator must follow monitoring requirements listed within R-111-Q. Tieback requirements shall be met within **180 days**.

Operator has proposed to pump down **intermediate 1 x intermediate 2** annulus post completion. **Operator must run Echo-meter to verify Cement Slurry/Fluid top in the annulus OR operator shall run a CBL from TD of the intermediate 2 casing to surface after the second stage BH to verify TOC.** Submit results to the BLM. No displacement fluid/wash out shall be utilized at the top of the cement slurry during second stage bradenhead when running Echo-meter if cement is required to surface. Adjust cement volume and excess based on a fluid caliper or similar method that reflects the as-drilled size of the wellbore.

Operator has proposed an open annulus completion in R-111-Q. Operator shall provide a method of verification pre-completion top of cement. **Submit results to the BLM. Pressure monitoring device and Pressure Safety Valves must be installed at surface on both the intermediate annulus and the production annulus for the life of the well.**

In the event of a casing failure during completion, the operator must contact the BLM at (575-706-2779) and (575-361-2822 Eddy County).

4. The 5-1/2 inch production casing shall be set at approximately **22,644** feet. The minimum required fill of cement behind the 5-1/2 inch production casing is:

Option 1 (Single Stage):

- Cement should tie-back **500 feet** into the previous casing but not higher than USGS Marker Bed No. 126. **Operator must verify top of cement per R-111-Q requirements.** Submit results to the BLM. If cement does not circulate, contact the appropriate BLM office. **Wait on cement (WOC) time for a primary cement job is to include the lead cement slurry due to cave/karst, Capitan Reef, or potash.**

C. PRESSURE CONTROL

1. Variance approved to use flex line from BOP to choke manifold. Manufacturer's specification to be readily available. No external damage to flex line. Flex line to be installed as straight as possible (no hard bends).
1. Operator has proposed a multi-bowl wellhead assembly. Minimum working pressure of the blowout preventer (BOP) and related equipment (BOPE) required for drilling below the surface casing shoe shall be **5000 (5M) psi. Variance is approved to use a 5000 (5M) Annular which shall be tested to 3500 psi.**
 - a. Wellhead shall be installed by manufacturer's representatives, submit documentation with subsequent sundry.
 - b. If the welding is performed by a third party, the manufacturer's representative shall monitor the temperature to verify that it does not exceed the maximum temperature of the seal.
 - c. Manufacturer representative shall install the test plug for the initial BOP test.
 - d. If the cement does not circulate and one-inch operations would have been possible with a standard wellhead, the well head shall be cut off, cementing operations performed and another wellhead installed.
 - e. Whenever any seal subject to test pressure is broken, all the tests in 43 CFR 3172 must be followed.

D. SPECIAL REQUIREMENT (S)

Communitization Agreement

- The operator will submit a Communitization Agreement to the Santa Fe Office, 301 Dinosaur Trail Santa Fe, New Mexico 87508, at least 90 days before the anticipated date of first production from a well subject to a spacing order issued by the New Mexico Oil Conservation Division. The Communitization Agreement will include the signatures of all working interest owners in all Federal and Indian leases subject to the Communitization Agreement (i.e., operating rights owners and lessees of record), or certification that the operator has obtained the written signatures of all such owners and will make those signatures available to the BLM immediately upon request.
- The operator will submit an as-drilled survey well plat of the well completion, but are not limited to, those specified in 43 CFR 3171 and 3172.
- If the operator does not comply with this condition of approval, the BLM may take enforcement actions that include, but are not limited to, those specified in 43 CFR 3163.1.
- In addition, the well sign shall include the surface and bottom hole lease numbers. When the Communitization Agreement number is known, it shall also be on the sign.

BOPE Break Testing Variance

- BOPE Break Testing is ONLY permitted for intervals utilizing a 5M BOPE or less. **(Annular preventer must be tested to a minimum of 70% of BOPE working pressure and shall be higher than the MASP.)**
- BOPE Break Testing is NOT permitted to drilling the production hole section.
- Variance only pertains to the intermediate hole-sections and no deeper than the Bone Springs formation.
- While in transfer between wells, the BOPE shall be secured by the hydraulic carrier or cradle.
- Any well control event while drilling require notification to the BLM Petroleum Engineer **(575-706-2779)** prior to the commencement of any BOPE Break Testing operations.
- A full BOPE test is required prior to drilling the first deep intermediate hole section. If any subsequent hole interval is deeper than the first, a full BOPE test will be required. (200' TVD tolerance between intermediate shoes is allowable).
- The BLM is to be contacted (575-361-2822 Eddy County) 4 hours prior to BOPE tests.
- As a minimum, a full BOPE test shall be performed at 21-day intervals.
- In the event any repairs or replacement of the BOPE is required, the BOPE shall test as per **43 CFR 3172**.
- If in the event break testing is not utilized, then a full BOPE test would be conducted.

Offline Cementing

Approved for surface and intermediate intervals. Notify the BLM prior to the commencement of any offline cementing procedure.

Casing Clearance

Overlap clearance OK.

GENERAL REQUIREMENTS

The BLM is to be notified in advance for a representative to witness:

- a. Spudding well (minimum of 24 hours)
- b. Setting and/or Cementing of all casing strings (minimum of 4 hours)
- c. BOPE tests (minimum of 4 hours)

Contact Eddy County Petroleum Engineering Inspection Staff:

Email or call the Carlsbad Field Office, 620 East Greene St., Carlsbad, NM 88220;

[BLM NM CFO DrillingNotifications@BLM.GOV](mailto:BLM_NM_CFO_DrillingNotifications@BLM.GOV); (575) 361-2822

1. Unless the production casing has been run and cemented or the well has been properly plugged, the drilling rig shall not be removed from over the hole without prior approval.
 - a. In the event the operator has proposed to drill multiple wells utilizing a skid/walking rig. Operator shall secure the wellbore on the current well, after installing and testing the wellhead, by installing a blind flange of like pressure rating to the wellhead and a pressure gauge that can be monitored while drilling is performed on the other well(s).
 - b. When the operator proposes to set surface casing with Spudder Rig
 - i. Notify the BLM when moving in and removing the Spudder Rig.
 - ii. Notify the BLM when moving in the 2nd Rig. Rig to be moved in within 90 days of notification that Spudder Rig has left the location.
 - iii. BOP/BOPE test to be conducted per **43 CFR 3172** as soon as 2nd Rig is rigged up on well.
2. Floor controls are required for 3M or Greater systems. These controls will be on the rig floor, unobstructed, readily accessible to the driller and will be operational at all times during drilling and/or completion activities. Rig floor is defined as the area immediately around the rotary table; the area immediately above the substructure on which the draw works are located, this does not include the dog house or stairway area.
3. For intervals in which cement to surface is required, cement to surface should be verified with a visual check and density or pH check to differentiate cement from spacer and drilling mud. The results should be documented in the driller's log and daily reports.

A. CASING

1. Changes to the approved APD casing program need prior approval if the items substituted are of lesser grade or different casing size or are Non-API. The Operator can exchange the components of the proposal with that of superior strength (i.e. changing from J-55 to N-80, or from 36# to 40#). Changes to the approved cement program need prior approval if the altered cement plan has less volume or strength or if the changes are substantial (i.e. Multistage tool, ECP, etc.). The initial wellhead installed on the well will remain on the well with spools used as needed.

2. Wait on cement (WOC) for Potash Areas: After cementing but before commencing any tests, the casing string shall stand cemented under pressure until both of the following conditions have been met: 1) cement reaches a minimum compressive strength of 500 psi for all cement blends of both lead and tail cement, 2) until cement has been in place at least 8 hours. WOC time will be recorded in the driller's log. The casing integrity test can be done (prior to the cement setting up) immediately after bumping the plug.
3. Wait on cement (WOC) for Water Basin: After cementing but before commencing any tests, the casing string shall stand cemented under pressure until both of the following conditions have been met: 1) cement reaches a minimum compressive strength of 500 psi at the shoe, 2) until cement has been in place at least 8 hours. WOC time will be recorded in the driller's log. See individual casing strings for details regarding lead cement slurry requirements. The casing integrity test can be done (prior to the cement setting up) immediately after bumping the plug.
4. Provide compressive strengths including hours to reach required 500 pounds compressive strength prior to cementing each casing string. Have well specific cement details onsite prior to pumping the cement for each casing string.
5. No pea gravel permitted for remedial or fall back remedial without prior authorization from the BLM engineer.
6. On that portion of any well approved for a 5M BOPE system or greater, a pressure integrity test of each casing shoe shall be performed. Formation at the shoe shall be tested to a minimum of the mud weight equivalent anticipated to control the formation pressure to the next casing depth or at total depth of the well. This test shall be performed before drilling more than 20 feet of new hole.
7. If hardband drill pipe is rotated inside casing, returns will be monitored for metal. If metal is found in samples, drill pipe will be pulled and rubber protectors which have a larger diameter than the tool joints of the drill pipe will be installed prior to continuing drilling operations.
8. Whenever a casing string is cemented in the R-111-Q potash area, the NMOCD requirements shall be followed.

B. PRESSURE CONTROL

1. All blowout preventer (BOP) and related equipment (BOPE) shall comply with well control requirements as described in **43 CFR 3172**.
2. If a variance is approved for a flexible hose to be installed from the BOP to the choke manifold, the following requirements apply: The flex line must meet the requirements of API 16C. Check condition of flexible line from BOP to choke manifold, replace if exterior is damaged or if line fails test. Line to be as straight as possible with no hard bends and is to be anchored according to Manufacturer's

requirements. The flexible hose can be exchanged with a hose of equal size and equal or greater pressure rating. Anchor requirements, specification sheet and hydrostatic pressure test certification matching the hose in service, to be onsite for review. These documents shall be posted in the company man's trailer and on the rig floor.

3. 5M or higher system requires an HCR valve, remote kill line and annular to match. The remote kill line is to be installed prior to testing the system and tested to stack pressure.
4. If the operator has proposed a multi-bowl wellhead assembly in the APD. The following requirements must be met:
 - i. Wellhead shall be installed by manufacturer's representatives, submit documentation with subsequent sundry.
 - ii. If the welding is performed by a third party, the manufacturer's representative shall monitor the temperature to verify that it does not exceed the maximum temperature of the seal.
 - iii. Manufacturer representative shall install the test plug for the initial BOP test.
 - iv. Whenever any seal subject to test pressure is broken, all the tests in 43 CFR 3172.6(b)(9) must be followed.
 - v. If the cement does not circulate and one inch operations would have been possible with a standard wellhead, the well head shall be cut off, cementing operations performed and another wellhead installed.
5. The appropriate BLM office shall be notified a minimum of 4 hours in advance for a representative to witness the tests.
 - i. In a water basin, for all casing strings utilizing slips, these are to be set as soon as the crew and rig are ready and any fallback cement remediation has been done. The casing cut-off and BOP installation can be initiated four hours after installing the slips, which will be approximately six hours after bumping the plug. For those casing strings not using slips, the minimum wait time before cut-off is eight hours after bumping the plug. BOP/BOPE testing can begin after cut-off or once cement reaches 500 psi compressive strength (including lead cement), whichever is greater. However, if the float does not hold, cut-off cannot be initiated until cement reaches 500 psi compressive strength (including lead when specified).
 - ii. In potash areas, for all casing strings utilizing slips, these are to be set as soon as the crew and rig are ready and any fallback cement remediation has been done. For all casing strings, casing cut-off and BOP installation can be initiated at twelve hours after bumping the cement plug. The BOPE test can be initiated after bumping the cement plug with the casing valve

- open. (only applies to single stage cement jobs, prior to the cement setting up.)
- iii. The tests shall be done by an independent service company utilizing a test plug not a cup or J-packer and can be initiated immediately with the casing valve open. The operator also has the option of utilizing an independent tester to test without a plug (i.e. against the casing) pursuant to **43 CFR 3172** with the pressure not to exceed 70% of the burst rating for the casing. Any test against the casing must meet the WOC time for 8 hours or 500 pounds compressive strength, whichever is greater, prior to initiating the test (see casing segment as lead cement may be critical item).
 - iv. The test shall be run on a 5000 psi chart for a 2-3M BOP/BOP, on a 10000 psi chart for a 5M BOP/BOPE and on a 15000 psi chart for a 10M BOP/BOPE. If a linear chart is used, it shall be a one hour chart. A circular chart shall have a maximum 2 hour clock. If a twelve hour or twenty-four hour chart is used, tester shall make a notation that it is run with a two hour clock.
 - v. The results of the test shall be reported to the appropriate BLM office.
 - vi. All tests are required to be recorded on a calibrated test chart. A copy of the BOP/BOPE test chart and a copy of independent service company test will be submitted to the appropriate BLM office.
 - vii. The BOP/BOPE test shall include a low pressure test from 250 to 300 psi. The test will be held for a minimum of 10 minutes if test is done with a test plug and 30 minutes without a test plug. This test shall be performed prior to the test at full stack pressure.
 - viii. BOP/BOPE must be tested by an independent service company within 500 feet of the top of the Wolfcamp formation if the time between the setting of the intermediate casing and reaching this depth exceeds 20 days. This test does not exclude the test prior to drilling out the casing shoe as per **43 CFR 3172**.

C. DRILLING MUD

Mud system monitoring equipment, with derrick floor indicators and visual and audio alarms, shall be operating before drilling into the Wolfcamp formation, and shall be used until production casing is run and cemented.

D. WASTE MATERIAL AND FLUIDS

All waste (i.e. drilling fluids, trash, salts, chemicals, sewage, gray water, etc.) created as a result of drilling operations and completion operations shall be safely contained and disposed of properly at a waste disposal facility. No waste material or fluid shall be

disposed of on the well location or surrounding area. Porto-johns and trash containers will be on-location during fracturing operations or any other crew-intensive operations.

KPI -12/29/2024



Permian Drilling Hydrogen Sulfide Drilling Operations Plan

Open drill site. No homes or buildings are near the proposed location.

1. Escape

Personnel shall escape upwind of wellbore in the event of an emergency gas release. Escape can take place through the lease road on the Southeast side of the location. Personnel need to move to a safe distance and block the entrance to location. If the primary route is not an option due to the wind direction, then a secondary egress route should be taken.



Permian Drilling Hydrogen Sulfide Drilling Operations Plan New Mexico

Scope

This contingency plan establishes guidelines for the public, all company employees, and contract employees who's work activities may involve exposure to hydrogen sulfide (H₂S) gas.

While drilling this well, it is possible to encounter H₂S bearing formations. At all times, the first barrier to control H₂S emissions will be the drilling fluid, which will have a density high enough to control influx.

Objective

1. Provide an immediate and predetermined response plan to any condition when H₂S is detected. All H₂S detections in excess of 10 parts per million (ppm) concentration are considered an Emergency.
2. Prevent any and all accidents, and prevent the uncontrolled release of hydrogen sulfide into the atmosphere.
3. Provide proper evacuation procedures to cope with emergencies.
4. Provide immediate and adequate medical attention should an injury occur.

Discussion

Implementation:	This plan with all details is to be fully implemented before drilling to <u>commence</u> .
Emergency response Procedure:	This section outlines the conditions and denotes steps to be taken in the event of an emergency.
Emergency equipment Procedure:	This section outlines the safety and emergency equipment that will be required for the drilling of this well.
Training provisions:	This section outlines the training provisions that must be adhered to prior to drilling.
Drilling emergency call lists:	Included are the telephone numbers of all persons to be contacted should an emergency exist.
Briefing:	This section deals with the briefing of all people involved in the drilling operation.
Public safety:	Public safety personnel will be made aware of any potential evacuation and any additional support needed.
Check lists:	Status check lists and procedural check lists have been included to insure adherence to the plan.
General information:	A general information section has been included to supply support information.

Hydrogen Sulfide Training

All personnel, whether regularly assigned, contracted, or employed on an unscheduled basis, will receive training from a qualified instructor in the following areas prior to commencing drilling operations on the well:

1. The hazards and characteristics of H2S.
2. Proper use and maintenance of personal protective equipment and life support systems.
3. H2S detection.
4. Proper use of H2S detectors, alarms, warning systems, briefing areas, evacuation procedures and prevailing winds.
5. Proper techniques for first aid and rescue procedures.
6. Physical effects of hydrogen sulfide on the human body.
7. Toxicity of hydrogen sulfide and sulfur dioxide.
8. Use of SCBA and supplied air equipment.
9. First aid and artificial respiration.
10. Emergency rescue.

In addition, supervisory personnel will be trained in the following areas:

1. The effects of H2S on metal components. If high tensile strength tubular is to be used, personnel will be trained in their special maintenance requirements.
2. Corrective action and shut-in procedures when drilling a well, blowout prevention and well control procedures.
3. The contents and requirements of the H2S Drilling Operations Plan.

H2S training refresher must have been taken within one year prior to drilling the well. Specifics on the well to be drilled will be discussed during the pre-spud meeting. H2S and well control (choke) drills will be performed while drilling the well, at least on a weekly basis. This plan shall be available in the well site. All personnel will be required to carry the documentation proving that the H2S training has been taken.

Service company and visiting personnel

- A. Each service company that will be on this well will be notified if the zone contains H2S.
- B. Each service company must provide for the training and equipment of their employees before they arrive at the well site.
- C. Each service company will be expected to attend a well site

Emergency Equipment Requirements

1. Well control equipment

The well shall have hydraulic BOP equipment for the anticipated pressures. Equipment is to be tested on installation and follow Oxy Well Control standard, as well as 43 CFR part 3170 Subpart 3172.

Special control equipment:

- A. Hydraulic BOP equipment with remote control on ground. Remotely operated choke.
- B. Rotating head
- C. Gas buster equipment shall be installed before drilling out of surface pipe.

2. Protective equipment for personnel

- A. Four (4) 30-minute positive pressure air packs (2 at each briefing area) on location.
- B. Adequate fire extinguishers shall be located at strategic locations.
- C. Radio / cell telephone communication will be available at the rig.
 - Rig floor and trailers.
 - Vehicle.

3. Hydrogen sulfide sensors and alarms

- A. H₂S sensor with alarms will be located on the rig floor, at the bell nipple, and at the flow line. These monitors will be set to alarm at 10 ppm with strobe light, and audible alarm.
- B. Hand operated detectors with tubes.
- C. H₂S monitor tester (to be provided by contract Safety Company.)
- D. There shall be one combustible gas detector on location at all times.

4. Visual Warning Systems

- A. One sign located at each location entrance with the following language:

**Caution – potential poison gas
Hydrogen sulfide
No admittance without authorization**

Wind sock – wind streamers:

- A. One 36” (in length) wind sock located at protection center, at height visible from rig floor.
- B. One 36” (in length) wind sock located at height visible from pit areas.

Condition flags

- A. One each condition flag to be displayed to denote conditions.

green – normal conditions
yellow – potential danger
red – danger, H2S present

- B. Condition flag shall be posted at each location sign entrance.

5. Mud Program

The mud program is designed to minimize the risk of having H2S and other formation fluids at surface. Proper mud weight and safe drilling practices will be applied. H2S scavengers will be used to minimize the hazards while drilling. Below is a summary of the drilling program.

Mud inspection devices:

Garrett gas train or hatch tester for inspection of sulfide concentration in mud system.

6. Metallurgy

- A. Drill string, casing, tubing, wellhead, blowout preventers, drilling spools or adapters, kill lines, choke manifold, lines and valves shall be suitable for the H2S service.
- B. All the elastomers, packing, seals and ring gaskets shall be suitable for H2S service.

7. Well Testing

No drill stem test will be performed on this well.

8. Evacuation plan

Evacuation routes should be established prior to well spud for each well and discussed with all rig personnel.

9. Designated area
- A. Parking and visitor area: all vehicles are to be parked at a predetermined safe distance from the wellhead.
 - B. There will be a designated smoking area.
 - C. Two briefing areas on either side of the location at the maximum allowable distance from the well bore so they offset prevailing winds perpendicularly, or at a 45-degree angle if wind direction tends to shift in the area.

Emergency procedures

- A. In the event of any evidence of H₂S level above 10 ppm, take the following steps:
 - 1. The Driller will pick up off bottom, shut down the pumps, slow down the pipe rotation.
 - 2. Secure and don escape breathing equipment, report to the upwind designated safe briefing / muster area.
 - 3. All personnel on location will be accounted for and emergency search should begin for any missing, the Buddy System will be implemented.
 - 4. Order non-essential personnel to leave the well site, order all essential personnel out of the danger zone and upwind to the nearest designated safe briefing / muster area.
 - 5. Entrance to the location will be secured to a higher level than our usual "Meet and Greet" requirement, and the proper condition flag will be displayed at the entrance to the location.
 - 6. Take steps to determine if the H₂S level can be corrected or suppressed and, if so, proceed as required.
- B. If uncontrollable conditions occur:
 - 1. Take steps to protect and/or remove any public in the down-wind area from the rig – partial evacuation and isolation. Notify necessary public safety personnel and appropriate regulatory entities (i.e. BLM) of the situation.

2. Remove all personnel to the nearest upwind designated safe briefing / muster area or off location.
3. Notify public safety personnel of safe briefing / muster area.
4. An assigned crew member will blockade the entrance to the location. No unauthorized personnel will be allowed entry to the location.
5. Proceed with best plan (at the time) to regain control of the well. Maintain tight security and safety procedures.

C. Responsibility:

1. Designated personnel.
 - a. Shall be responsible for the total implementation of this plan.
 - b. Shall be in complete command during any emergency.
 - c. Shall designate a back-up.

- All personnel:
1. On alarm, don escape unit and report to the nearest upwind designated safe briefing / muster area upw
 2. Check status of personnel (buddy system).
 3. Secure breathing equipment.
 4. Await orders from supervisor.

- Drill site manager:
1. Don escape unit if necessary and report to nearest upwind designated safe briefing / muster area.
 2. Coordinate preparations of individuals to return to point of release with tool pusher and driller (using the buddy system).
 3. Determine H2S concentrations.
 4. Assess situation and take control measures.

- Tool pusher:
1. Don escape unit Report to up nearest upwind designated safe briefing / muster area.
 2. Coordinate preparation of individuals to return to point of release with tool pusher drill site manager (using the buddy system).
 3. Determine H2S concentration.
 4. Assess situation and take control measures.

- Driller:
1. Don escape unit, shut down pumps, continue

- rotating DP.
- 2. Check monitor for point of release.
- 3. Report to nearest upwind designated safe briefing / muster area.
- 4. Check status of personnel (in an attempt to rescue, use the buddy system).
- 5. Assigns least essential person to notify Drill Site Manager and tool pusher by quickest means in case of their absence.
- 6. Assumes the responsibilities of the Drill Site Manager and tool pusher until they arrive should they be absent.

Derrick man
 Floor man #1
 Floor man #2

- 1. Will remain in briefing / muster area until instructed by supervisor.

Mud engineer:

- 1. Report to nearest upwind designated safe briefing / muster area.
- 2. When instructed, begin check of mud for ph and H2S level. (Garett gas train.)

Safety personnel:

- 1. Mask up and check status of all personnel and secure operations as instructed by drill site manager.

Taking a kick

When taking a kick during an H2S emergency, all personnel will follow standard Well control procedures after reporting to briefing area and masking up.

Open-hole logging

All unnecessary personnel off floor. Drill Site Manager and safety personnel should monitor condition, advise status and determine need for use of air equipment.

Running casing or plugging

Following the same “tripping” procedure as above. Drill Site Manager and safety personnel should determine if all personnel have access to protective equipment.

Ignition procedures

The decision to ignite the well is the responsibility of the operator (Oxy Drilling Management). The decision should be made only as a last resort and in a situation where it is clear that:

1. Human life and property are endangered.
2. There is no hope controlling the blowout under the prevailing conditions at the well.

Instructions for igniting the well

1. Two people are required for the actual igniting operation. They must wear self-contained breathing units and have a safety rope attached. One man (tool pusher or safety engineer) will check the atmosphere for explosive gases with the gas monitor. The other man is responsible for igniting the well.
2. Primary method to ignite: 25 mm flare gun with range of approximately 500 feet.
3. Ignite upwind and do not approach any closer than is warranted.
4. Select the ignition site best for protection, and which offers an easy escape route.
5. Before firing, check for presence of combustible gas.
6. After lighting, continue emergency action and procedure as before.
7. All unassigned personnel will remain in briefing area until instructed by supervisor or directed by the Drill Site Manager.

Remember: After well is ignited, burning hydrogen sulfide will convert to sulfur dioxide, which is also highly toxic. **Do not assume the area is safe after the well is ignited.**

Status check list

Note: All items on this list must be completed before drilling to production casing point.

1. H2S sign at location entrance.
2. Two (2) wind socks located as required.
3. Four (4) 30-minute positive pressure air packs (2 at each Briefing area) on location for all rig personnel and mud loggers.
4. Air packs inspected and ready for use.
5. Cascade system and hose line hook-up as needed.
6. Cascade system for refilling air bottles as needed.
7. Condition flag on location and ready for use.
8. H2S detection system hooked up and tested.
9. H2S alarm system hooked up and tested.
10. Hand operated H2S detector with tubes on location.
11. 1 – 100' length of nylon rope on location.
12. All rig crew and supervisors trained as required.
13. All outside service contractors advised of potential H2S hazard on well.
14. No smoking sign posted and a designated smoking area identified.
15. Calibration of all H2S equipment shall be noted on the IADC report.

Checked by: _____ Date:

Procedural check list during H2S events

Perform each tour:

1. Check fire extinguishers to see that they have the proper charge.
2. Check breathing equipment to ensure that it is in proper working order.
3. Make sure all the H2S detection system is operative.

Perform each week:

1. Check each piece of breathing equipment to make sure that demand or forced air regulator is working. This requires that the bottle be opened and the mask assembly be put on tight enough so that when you inhale, you receive air or feel air flow.
2. BOP skills (well control drills).
3. Check supply pressure on BOP accumulator stand by source.
4. Check breathing equipment mask assembly to see that straps are loosened and turned back, ready to put on.
5. Check pressure on breathing equipment air bottles to make sure they are charged to full volume. (Air quality checked for proper air grade "D" before bringing to location)
6. Confirm pressure on all supply air bottles.
7. Perform breathing equipment drills with on-site personnel.
8. Check the following supplies for availability.
 - A. Emergency telephone list.
 - B. Hand operated H2S detectors and tubes.

General evacuation plan

1. When the company approved supervisor (Drill Site Manager, consultant, rig pusher, or driller) determines the H2S gas cannot be limited to the well location and the public will be involved, he will activate the evacuation plan.
2. Drill Site Manager or designee will notify local government agency that a hazardous condition exists and evacuation needs to be implemented.
3. Company or contractor safety personnel that have been trained in the use of H2S detection equipment and self-contained breathing equipment will monitor H2S concentrations, wind directions, and area of exposure. They will delineate the outer perimeter of the hazardous gas area. Extension to the evacuation area will be determined from information gathered.
4. Law enforcement personnel (state police, police dept., fire dept., and sheriff's dept.) Will be called to aid in setting up and maintaining road blocks. Also, they will aid in evacuation of the public if necessary.
5. After the discharge of gas has been controlled, company safety personnel will determine when the area is safe for re-entry.

Important: Law enforcement personnel will not be asked to come into a contaminated area. Their assistance will be limited to uncontaminated areas. Constant radio contact will be maintained with them.

Emergency actions

Well blowout – if emergency

1. Evacuate all personnel to “Safe Briefing / Muster Areas” or off location if needed.
2. If sour gas – evacuate rig personnel.
3. If sour gas – evacuate public within 3000 ft radius of exposure.
4. Don SCBA and shut well in if possible using the buddy system.
5. Notify Drilling Superintendent and call 911 for emergency help (fire dept and ambulance) if needed.
6. Implement the Blowout Contingency Plan, and Drilling Emergency Action Plan.
6. Give first aid as needed.

Person down location/facility

1. If immediately possible, contact 911. Give location and wait for confirmation.
2. Don SCBA and perform rescue operation using buddy system.

Toxic effects of hydrogen sulfide

Hydrogen sulfide is extremely toxic. The acceptable ceiling concentration for eight-hour exposure is 10 ppm, which is .001% by volume. Hydrogen sulfide is heavier than air (specific gravity – 1.192) and colorless. It forms an explosive mixture with air between 4.3 and 46.0 percent by volume. Hydrogen sulfide is almost as toxic as hydrogen cyanide and is between five and six times more toxic than carbon monoxide. Toxicity data for hydrogen sulfide and various other gases are compared in table i. Physical effects at various hydrogen sulfide exposure levels are shown in table ii.

Table i
Toxicity of various gases

Common name	Chemical formula	Specific gravity (sc=1)	Threshold limit (1)	Hazardous limit (2)	Lethal concentration (3)
Hydrogen Cyanide	Hcn	0.94	10 ppm	150 ppm/hr	300 ppm
Hydrogen Sulfide	H2S	1.18	10 ppm	250 ppm/hr	600 ppm
Sulfur Dioxide	So2	2.21	5 ppm	-	1000 ppm
Chlorine	Cl2	2.45	1 ppm	4 ppm/hr	1000 ppm
Carbon Monoxide	Co	0.97	50 ppm	400 ppm/hr	1000 ppm
Carbon Dioxide	Co2	1.52	5000 ppm	5%	10%
Methane	Ch4	0.55	90,000 ppm	Combustible above 5% in air	

- 1) threshold limit – concentration at which it is believed that all workers may be repeatedly exposed day after day without adverse effects.
- 2) hazardous limit – concentration that will cause death with short-term exposure.
- 3) lethal concentration – concentration that will cause death with short-term exposure.

Toxic effects of hydrogen sulfide

Table ii
Physical effects of hydrogen sulfide

Percent (%)	Ppm	Concentration Grains 100 std. Ft3*	Physical effects
0.001	<10	00.65	Obvious and unpleasant odor.

0.002	10	01.30	Safe for 8 hours of exposure.
0.010	100	06.48	Kill smell in 3 – 15 minutes. May sting eyes and throat.
0.020	200	12.96	Kills smell shortly; stings eyes and throat.
0.050	500	32.96	Dizziness; breathing ceases in a few minutes; needs prompt artificial respiration.
0.070	700	45.36	Unconscious quickly; death will result if not rescued promptly.
0.100	1000	64.30	Unconscious at once; followed by death within minutes.

*at 15.00 psia and 60’f.

Use of self-contained breathing equipment (SCBA)

1. Written procedures shall be prepared covering safe use of SCBA's in dangerous atmosphere, which might be encountered in normal operations or in emergencies. Personnel shall be familiar with these procedures and the available SCBA.
2. SCBA's shall be inspected frequently at random to insure that they are properly used, cleaned, and maintained.
3. Anyone who may use the SCBA's shall be trained in how to insure proper face-piece to face seal. They shall wear SCBA's in normal air and then wear them in a test atmosphere. (note: such items as facial hair {beard or sideburns} and eyeglasses will not allow proper seal.) Anyone that may be reasonably expected to wear SCBA's should have these items removed before entering a toxic atmosphere. A special mask must be obtained for anyone who must wear eyeglasses or contact lenses.
4. Maintenance and care of SCBA's:
 - a. A program for maintenance and care of SCBA's shall include the following:
 1. Inspection for defects, including leak checks.
 2. Cleaning and disinfecting.
 3. Repair.
 4. Storage.
 - b. Inspection, self-contained breathing apparatus for emergency use shall be inspected monthly.
 1. Fully charged cylinders.
 2. Regulator and warning device operation.
 3. Condition of face piece and connections.
 4. Rubber parts shall be maintained to keep them pliable and prevent deterioration.
 - c. Routinely used SCBA's shall be collected, cleaned and disinfected as frequently as necessary to insure proper protection is provided.
5. Persons assigned tasks that requires use of self-contained breathing equipment shall be certified physically fit (medically cleared) for breathing equipment usage at least annually.
6. SCBA's should be worn when:
 - A. Any employee works near the top or on top of any tank unless test reveals less than 10 ppm of H₂S.

- B. When breaking out any line where H2S can reasonably be expected.
- C. When sampling air in areas to determine if toxic concentrations of H2S exists.
- D. When working in areas where over 10 ppm H2S has been detected.
- E. At any time there is a doubt as to the H2S level in the area to be entered.

Rescue
First aid for H2S poisoning

Do not panic!

Remain calm – think!

1. Don SCBA breathing equipment.
2. Remove victim(s) utilizing buddy system to fresh air as quickly as possible. (go up-wind from source or at right angle to the wind. Not down wind.)
3. Briefly apply chest pressure – arm lift method of artificial respiration to clean the victim’s lungs and to avoid inhaling any toxic gas directly from the victim’s lungs.
4. Provide for prompt transportation to the hospital, and continue giving artificial respiration if needed.
5. Hospital(s) or medical facilities need to be informed, before-hand, of the possibility of H2S gas poisoning – no matter how remote the possibility is.
6. Notify emergency room personnel that the victim(s) has been exposed to H2S gas.

Besides basic first aid, everyone on location should have a good working knowledge of artificial respiration.

Revised CM 6/27/2012

Choke Manifold – Gas Separator (Top View)

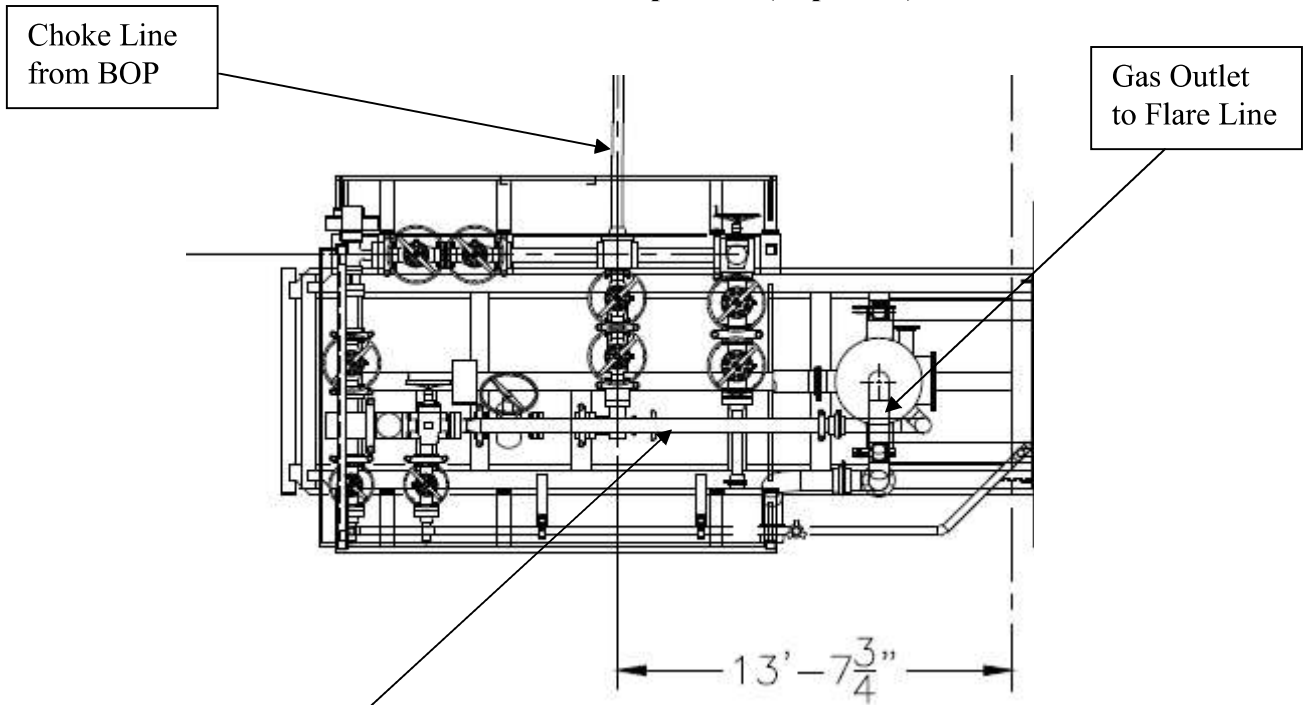

Choke Manifold – Gas Separator (Side View)

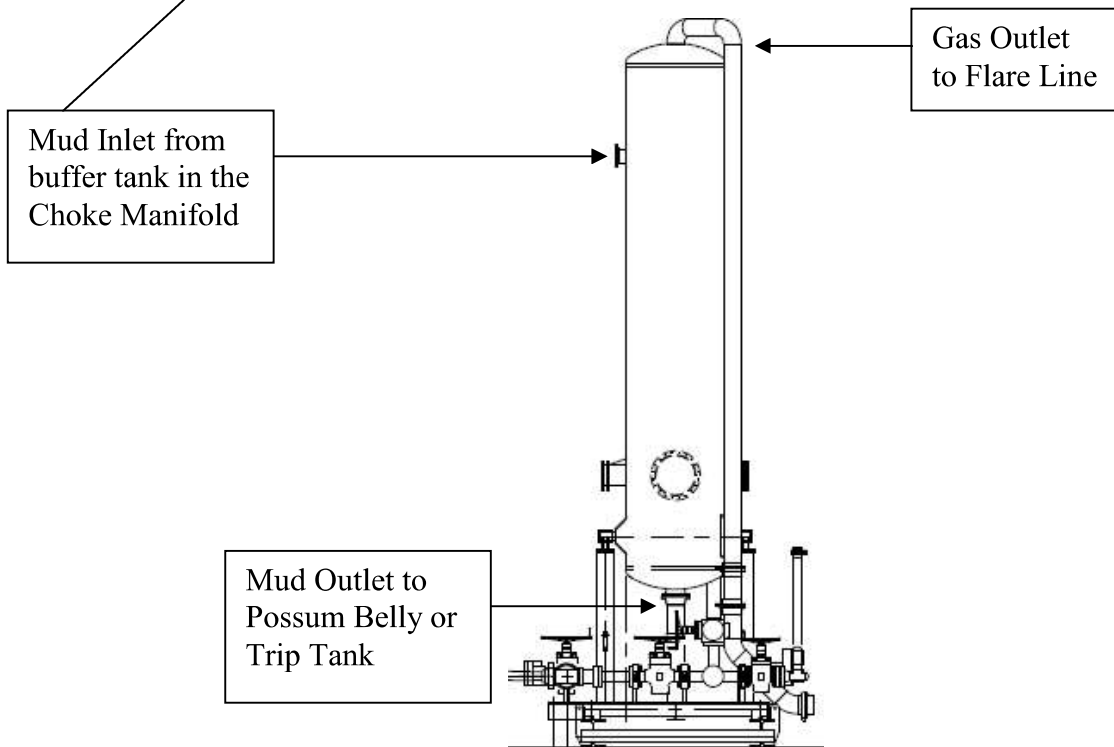



SITE PLAN

AVID DIVA 35_11 FED COM
 (LSTTNK_22S31E_3502) WELL PAD
 SEC. 35 TWP. 21-S RGE. 31-E
 SURVEY: N.M.P.M.
 COUNTY: EDDY
 OPERATOR: OXY USA, INC.
 U.S.G.S. TOPOGRAPHIC MAP: THE DIVIDE, N.M.
 FAA PERMIT NEEDED: NO

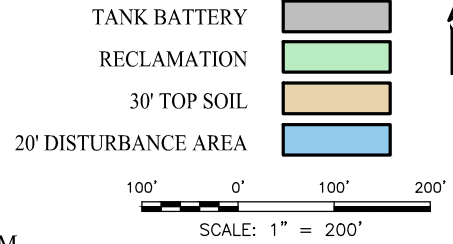

NAD 83		
A	E:(X)723742.41 N:(Y)522508.36	LAT:32.43505362 LON:-103.74210352
B	E:(X)723742.27 N:(Y)522023.36	LAT:32.43372053 LON:-103.74211267
C	E:(X)723642.27 N:(Y)522023.44	LAT:32.43372225 LON:-103.74243676
D	E:(X)722867.29 N:(Y)522023.44	LAT:32.43373402 LON:-103.74494857
E	E:(X)722867.21 N:(Y)522508.41	LAT:32.43506704 LON:-103.74494017
F	E:(X)723642.37 N:(Y)522508.43	LAT:32.43505534 LON:-103.74242776

NAD 27		
A	E:(X)682560.61 N:(Y)522447.46	LAT:32.43493129 LON:-103.74161240
B	E:(X)682560.46 N:(Y)521962.47	LAT:32.43359818 LON:-103.74162161
C	E:(X)682460.46 N:(Y)521962.55	LAT:32.43359993 LON:-103.74194570
D	E:(X)681685.49 N:(Y)521962.56	LAT:32.43361170 LON:-103.74445742
E	E:(X)681685.42 N:(Y)522447.51	LAT:32.43494473 LON:-103.74444897
F	E:(X)682460.57 N:(Y)522447.53	LAT:32.43493301 LON:-103.74193663

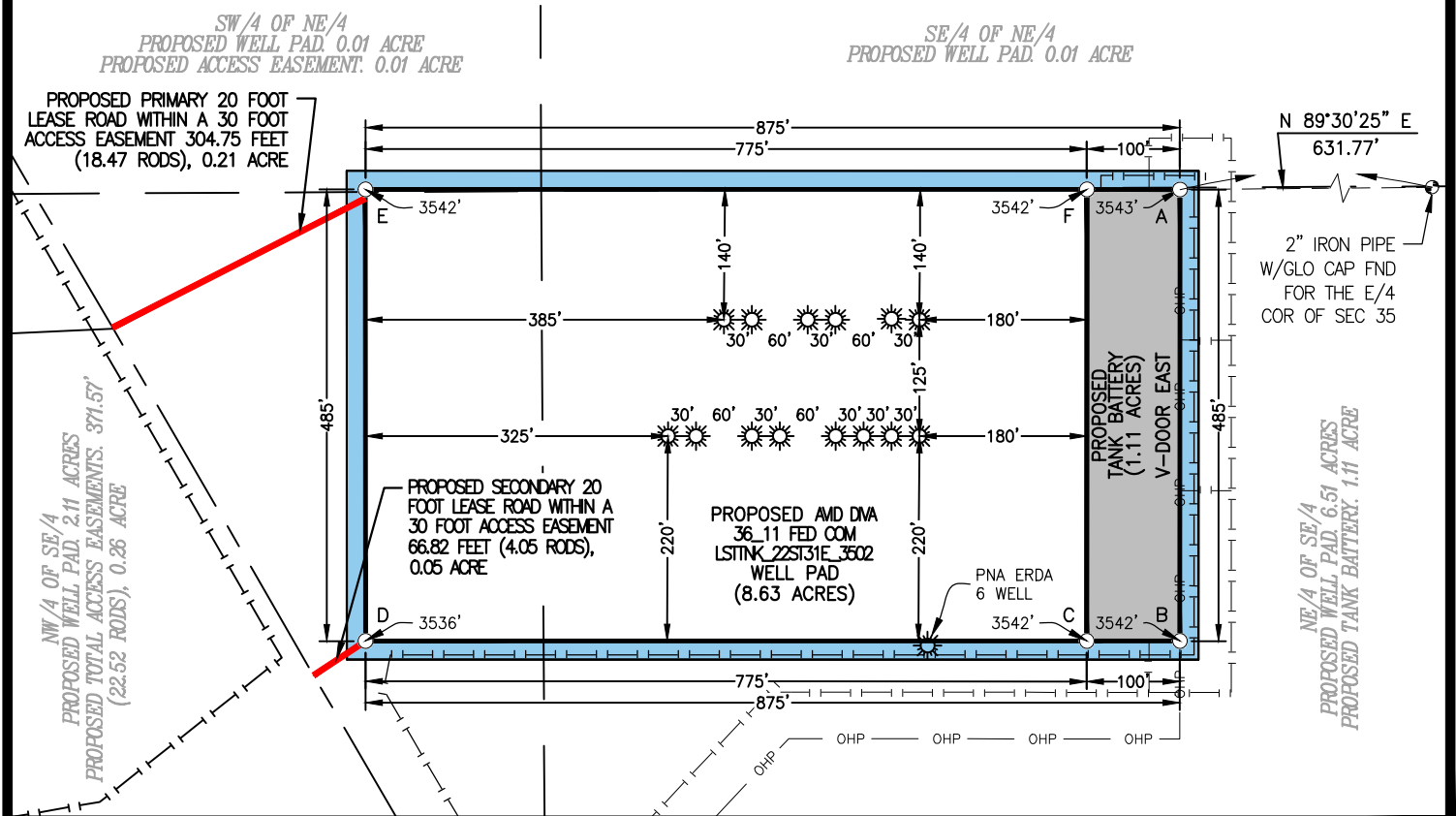

12/21/2023	01/18/2024
DATE SURVEYED	DATE DRAWN

I, DAVID W. MYERS, NEW MEXICO PROFESSIONAL SURVEYOR NO. 11403 DO HEREBY CERTIFY THAT THIS EASEMENT SURVEY PLAT AND THE ACTUAL SURVEY ON THE GROUND UPON WHICH IT IS BASED WERE PERFORMED BY ME OR UNDER MY DIRECT SUPERVISION; THAT I AM RESPONSIBLE FOR THIS SURVEY; THAT THIS SURVEY MEETS THE MINIMUM STANDARDS FOR SURVEYING IN NEW MEXICO; AND THAT IT IS TRUE AND CORRECT TO THE BEST OF MY KNOWLEDGE AND BELIEF. I FURTHER CERTIFY THAT THIS SURVEY IS NOT A LAND DIVISION OR SUBDIVISION AS DEFINED IN THE NEW MEXICO SUBDIVISION ACT AND THAT THIS INSTRUMENT IS AN EASEMENT SURVEY PLAT CROSSING AN EXISTING TRACT OR TRACTS.

0	01/18/2024	ANC
REV.	DATE	BY

BASIS OF BEARING
 ALL BEARINGS AND COORDINATES REFER TO NAD 83, NEW MEXICO STATE PLANE COORDINATE SYSTEM, EAST ZONE, U.S. SURVEY FEET. ALL BEARINGS, DISTANCES, COORDINATES AND AREAS ARE GRID MEASUREMENTS UTILIZING A COMBINED SCALE FACTOR OF 0.999777483 AND A CONVERGENCE ANGLE OF 0.313558824°.

LEGEND	
	EXISTING ROAD
	PROPOSED ROAD
	SURFACE SITE EDGE
	EXIST. PIPELINE
	MONUMENT
	QUARTER SPLIT
	OHP
	FENCE
	SECTION LINE
	PROPERTY LINE
	WATER LINE
	SALT WATER LINE

JANUARY 19, 2024

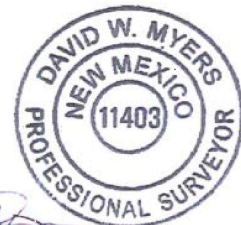

DAVID W. MYERS 11403



PREPARED BY:
 DELTA FIELD SERVICES, LLC
 510 TRENTON ST.
 WEST MONROE, LA 71291
 318-323-6900 OFFICE
 JOB No. R4223_008
 SHEET 2 OF 5



SITE PLAN

AVID DIVA 35_11 FED COM
 (LSTTNK_22S31E_3502) WELL PAD
 SEC. 35 TWP. 21-S RGE. 31-E
 SURVEY: N.M.P.M.
 COUNTY: EDDY
 OPERATOR: OXY USA, INC.
 U.S.G.S. TOPOGRAPHIC MAP: THE DIVIDE, N.M.
 FAA PERMIT NEEDED: NO

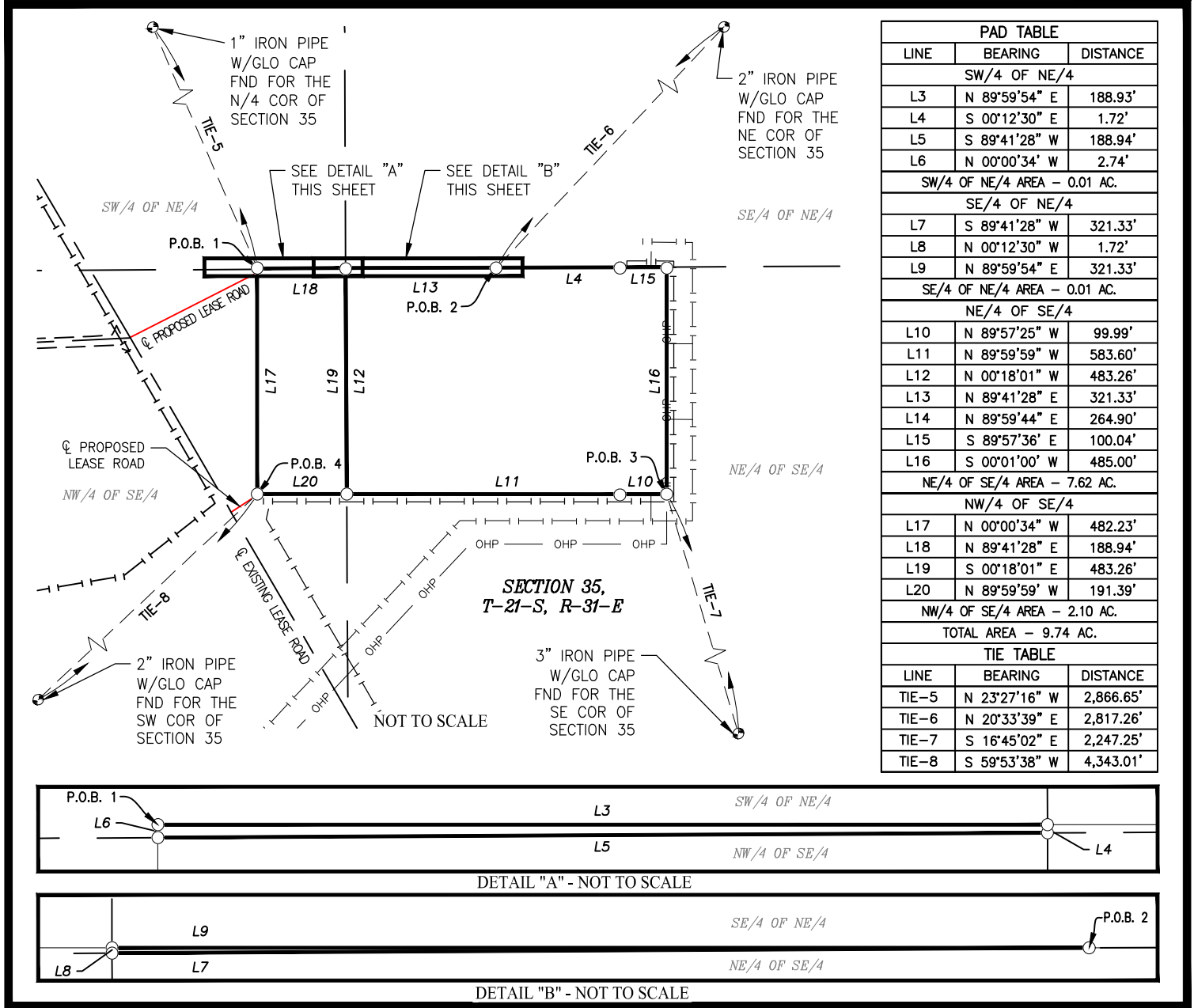

PAD TABLE		
LINE	BEARING	DISTANCE
SW/4 OF NE/4		
L3	N 89°59'54" E	188.93'
L4	S 00°12'30" E	1.72'
L5	S 89°41'28" W	188.94'
L6	N 00°00'34" W	2.74'
SW/4 OF NE/4 AREA - 0.01 AC.		
SE/4 OF NE/4		
L7	S 89°41'28" W	321.33'
L8	N 00°12'30" W	1.72'
L9	N 89°59'54" E	321.33'
SE/4 OF NE/4 AREA - 0.01 AC.		
NE/4 OF SE/4		
L10	N 89°57'25" W	99.99'
L11	N 89°59'59" W	583.60'
L12	N 00°18'01" W	483.26'
L13	N 89°41'28" E	321.33'
L14	N 89°59'44" E	264.90'
L15	S 89°57'36" E	100.04'
L16	S 00°01'00" W	485.00'
NE/4 OF SE/4 AREA - 7.62 AC.		
NW/4 OF SE/4		
L17	N 00°00'34" W	482.23'
L18	N 89°41'28" E	188.94'
L19	S 00°18'01" E	483.26'
L20	N 89°59'59" W	191.39'
NW/4 OF SE/4 AREA - 2.10 AC.		
TOTAL AREA - 9.74 AC.		
TIE TABLE		
LINE	BEARING	DISTANCE
TIE-5	N 23°27'16" W	2,866.65'
TIE-6	N 20°33'39" E	2,817.26'
TIE-7	S 16°45'02" E	2,247.25'
TIE-8	S 59°53'38" W	4,343.01'

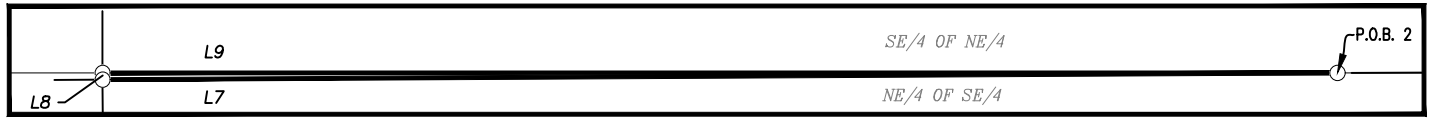
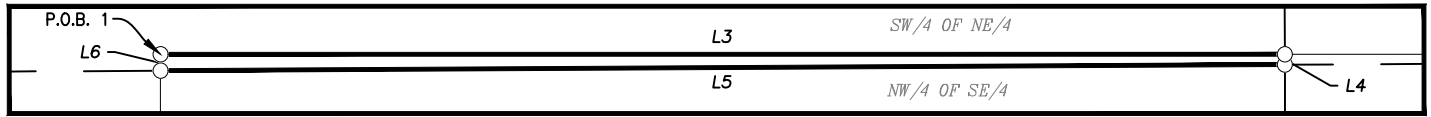

12/21/2023	01/18/2024
DATE SURVEYED	DATE DRAWN

I, DAVID W. MYERS, NEW MEXICO PROFESSIONAL SURVEYOR NO. 11403 DO HEREBY CERTIFY THAT THIS EASEMENT SURVEY PLAT AND THE ACTUAL SURVEY ON THE GROUND UPON WHICH IT IS BASED WERE PERFORMED BY ME OR UNDER MY DIRECT SUPERVISION; THAT I AM RESPONSIBLE FOR THIS SURVEY; THAT THIS SURVEY MEETS THE MINIMUM STANDARDS FOR SURVEYING IN NEW MEXICO; AND THAT IT IS TRUE AND CORRECT TO THE BEST OF MY KNOWLEDGE AND BELIEF. I FURTHER CERTIFY THAT THIS SURVEY IS NOT A LAND DIVISION OR SUBDIVISION AS DEFINED IN THE NEW MEXICO SUBDIVISION ACT AND THAT THIS INSTRUMENT IS AN EASEMENT SURVEY PLAT CROSSING AN EXISTING TRACT OR TRACTS.

0	01/18/2024	ANC
REV.	DATE	BY

BASIS OF BEARING

ALL BEARINGS AND COORDINATES REFER TO NAD 83, NEW MEXICO STATE PLANE COORDINATE SYSTEM, EAST ZONE, U.S. SURVEY FEET. ALL BEARINGS, DISTANCES, COORDINATES AND AREAS ARE GRID MEASUREMENTS UTILIZING A COMBINED SCALE FACTOR OF 0.999777483 AND A CONVERGENCE ANGLE OF 0.313558824°.

LEGEND	
	EXISTING ROAD
	PROPOSED ROAD
	SURFACE SITE EDGE
	EXIST. PIPELINE
	MONUMENT
	QUARTER SPLIT
	OHP OVERHEAD POWER FENCE
	SECTION LINE
	PROPERTY LINE
	WATER LINE
	SALT WATER LINE

JANUARY 19, 2024



DAVID W. MYERS 11403



PREPARED BY:
 DELTA FIELD SERVICES, LLC
 510 TRENTON ST.
 WEST MONROE, LA 71291
 318-323-6900 OFFICE
 JOB No. R4223_008
 SHEET 3 OF 5



SITE PLAN
 AVID DIVA 35_11 FED COM
 (LSTTNK_22S31E_3502) WELL PAD
 SEC. 35 TWP. 21-S RGE. 31-E
 SURVEY: N.M.P.M.
 COUNTY: EDDY
 OPERATOR: OXY USA, INC.
 U.S.G.S. TOPOGRAPHIC MAP: THE DIVIDE, N.M.
 FAA PERMIT NEEDED: NO



A tract of land being 9.74 acres of land. Said easement being located in Section 35, Township 21 South, Range 31 East, New Mexico Principal Meridian, Eddy County, New Mexico.

Being more particularly described as the following (see Details "A" and "B" on sheet 3 of 5):

(SW/4 OF NE/4)

BEGINNING (POINT OF BEGINNING 1) at a point from which a 1 inch iron pipe with GLO cap found for the North quarter corner of said Section 35 bears N 23°27'16" W a distance of 2,866.65 feet.

THENCE across the said Southwest quarter of the Northeast quarter of Section 35 the following courses and distances:

N 89°59'54" E a distance of 188.93 feet, S 00°12'30" E a distance of 1.72 feet, S 89°41'28" W a distance of 188.94 feet and N 00°00'34" W a distance of 2.74 feet to the PLACE OF BEGINNING 1.

The area of the above described proposed permanent easement in the said Southwest quarter of the Northeast quarter of Section 35 containing 0.01 acre of land.

(SE/4 OF NE/4)

BEGINNING (POINT OF BEGINNING 2) at a point from which a 2 inch iron pipe with GLO cap found for the Northeast corner of said Section 35 bears N 20°33'39" E a distance of 2,817.26 feet.

THENCE continuing across the said Southeast quarter of the Northeast quarter of Section 35 the following courses and distances:

S 89°41'28" W a distance of 321.33 feet, N 00°12'30" W a distance of 1.72 feet, and N 89°59'54" E a distance of 321.33 feet to the PLACE OF BEGINNING 2.

The area of the above described proposed permanent easement in the said Southeast quarter of the Northeast quarter of Section 35 containing 0.01 acre of land.

(NE/4 OF SE/4)

BEGINNING (POINT OF BEGINNING 3) at a point from which a 3 inch iron pipe with GLO cap found for the Southeast corner of said Section 35 bears S 16°45'02" E a distance of 2,247.25 feet.

THENCE continuing across the said Northeast quarter of the Southeast quarter of Section 35 the following courses and distances:

N 89°57'25" W a distance of 99.99 feet, N 89°59'59" W a distance of 583.60 feet, N 00°18'01" W a distance of 483.26 feet, N 89°41'28" E a distance of 321.33 feet, N 89°59'44" E a distance of 264.90 feet, S 89°57'36" E a distance of 100.04 feet and S 00°01'00" W a distance of 485.00 feet to the PLACE OF BEGINNING 3.

The area of the above described proposed permanent easement in the said Northeast quarter of the Southeast quarter of Section 35 containing 7.62 acres of land.

(NW/4 OF SE/4)

BEGINNING (POINT OF BEGINNING 4) at a point from which a 2 inch iron pipe with GLO cap found for the Southwest corner of said Section 35 bears S 59°53'38" W a distance of 4,343.01 feet.

THENCE continuing across the said Northwest quarter of the Southeast quarter of Section 35 the following courses and distances:

N 00°00'34" W a distance of 482.23 feet, N 89°41'28" E a distance of 188.94 feet, S 00°18'01" E a distance of 483.26 feet and N 89°59'59" W a distance of 191.39 feet to the PLACE OF BEGINNING 4.

The area of the above described proposed permanent easement in the said Northwest quarter of the Southeast quarter of Section 35 containing 2.10 acres of land.

The total area of the above described permanent easement in said Section 35 containing 9.74 acres of land.

All bearings and coordinates refer to NAD 83, New Mexico State Plane Coordinate System, East Zone, U.S. Survey Feet. All bearings, distances, coordinates and areas are grid measurements utilizing a combined scale factor of 0.999777483 and a convergence angle of 0.313558824°.

Title information furnished by OXY USA INC.

Reference accompanying Certificate of Survey prepared in conjunction with this legal description for easement.

STATE OF NEW MEXICO
 COUNTY OF EDDY

I, David W. Myers, New Mexico Professional Surveyor No. 11403 do hereby certify that this easement survey plat and the actual survey on the ground upon which it is based were performed by me or under my direct supervision; that I am responsible for this survey; that this survey meets the minimum standards for surveying in New Mexico; and that it is true and correct to the best of my knowledge and belief. I further certify that this survey is not a land division or subdivision as defined in the New Mexico Subdivision Act and that this instrument is an easement survey plat crossing an existing tract or tracts.

12/21/2023	01/18/2024
DATE SURVEYED	DATE DRAWN

0	01/18/2024	ANC
REV.	DATE	BY

LEGEND

	EXISTING ROAD		OHP	OVERHEAD POWER
	PROPOSED ROAD		FENCE	FENCE
	SURFACE SITE EDGE		SECTION LINE	SECTION LINE
	EXIST. PIPELINE		PROPERTY LINE	PROPERTY LINE
	MONUMENT		WATER LINE	WATER LINE
	QUARTER SPLIT		SALT WATER LINE	SALT WATER LINE

JANUARY 19, 2024

DAVID W. MYERS 11403

PREPARED BY:
 DELTA FIELD SERVICES, LLC
 510 TRENTON ST.
 WEST MONROE, LA 71291
 318-323-6900 OFFICE
 JOB No. R4223_008
 SHEET 4 OF 5



SITE PLAN

AVID DIVA 35_11 FED COM
 (LSTTNK_22S31E_3502) WELL PAD
 SEC. 35 TWP. 21-S RGE. 31-E
 SURVEY: N.M.P.M.

COUNTY: EDDY

OPERATOR: OXY USA, INC.

U.S.G.S. TOPOGRAPHIC MAP: THE DIVIDE, N.M.

FAA PERMIT NEEDED: NO



<p>WELL 1 AVID DIVA 35_11 FED COM 23H OXY USA, INC. 2,503' FSL 1,123' FEL, SECTION 35 NAD 83, SPCS NM EAST X:723252.40' / Y:522368.45' LAT:32.43467650N / LON:103.7436420W NAD 27, SPCS NM EAST X:682070.61' / Y:522307.56' LAT:32.43455418N / LON:103.74320306W ELEVATION = 3540'</p>	<p>WELL 2 AVID DIVA 35_11 FED COM 24H OXY USA, INC. 2,503' FSL 1,093' FEL, SECTION 35 NAD 83, SPCS NM EAST X:723282.34' / Y:522368.44' LAT:32.43467602N / LON:103.74359716W NAD 27, SPCS NM EAST X:682100.55' / Y:522307.55' LAT:32.43455371N / LON:103.74310602W ELEVATION = 3539'</p>	<p>WELL 3 AVID DIVA 35_11 FED COM 13H OXY USA, INC. 2,502' FSL 1,033' FEL, SECTION 35 NAD 83, SPCS NM EAST X:723342.30' / Y:522368.46' LAT:32.43467515N / LON:103.74340283W NAD 27, SPCS NM EAST X:682160.50' / Y:522307.56' LAT:32.43455284N / LON:103.74291170W ELEVATION = 3540'</p>	<p>WELL 4 AVID DIVA 35_11 FED COM 14H OXY USA, INC. 2,502' FSL 1,003' FEL, SECTION 35 NAD 83, SPCS NM EAST X:723372.25' / Y:522368.37' LAT:32.43467447N / LON:103.74330577W NAD 27, SPCS NM EAST X:682190.45' / Y:522307.48' LAT:32.43455215N / LON:103.74281464W ELEVATION = 3540'</p>
<p>WELL 5 AVID DIVA 35_11 FED COM 3H OXY USA, INC. 2,503' FSL 943' FEL, SECTION 35 NAD 83, SPCS NM EAST X:723432.36' / Y:522369.41' LAT:32.43467641N / LON:103.74311091W NAD 27, SPCS NM EAST X:682250.56' / Y:522308.52' LAT:32.43455409N / LON:103.74261978W ELEVATION = 3539'</p>	<p>WELL 6 AVID DIVA 35_11 FED COM 4H OXY USA, INC. 2,502' FSL 913' FEL, SECTION 35 NAD 83, SPCS NM EAST X:723462.38' / Y:522368.41' LAT:32.43467319N / LON:103.74301364W NAD 27, SPCS NM EAST X:682280.58' / Y:522307.51' LAT:32.43455087N / LON:103.74252252W ELEVATION = 3540'</p>	<p>WELL 7 AVID DIVA 35_11 FED COM 43H OXY USA, INC. 2,378' FSL 1,183' FEL, SECTION 35 NAD 83, SPCS NM EAST X:723192.32' / Y:522243.49' LAT:32.43433392N / LON:103.74389118W NAD 27, SPCS NM EAST X:682010.52' / Y:522182.59' LAT:32.43421160N / LON:103.74340005W ELEVATION = 3541'</p>	<p>WELL 8 AVID DIVA 35_11 FED COM 44H OXY USA, INC. 2,378' FSL 1,153' FEL, SECTION 35 NAD 83, SPCS NM EAST X:723222.38' / Y:522243.40' LAT:32.43433323N / LON:103.74379376W NAD 27, SPCS NM EAST X:682040.58' / Y:522182.51' LAT:32.43421091N / LON:103.74330263W ELEVATION = 3542'</p>
<p>WELL 9 AVID DIVA 35_11 FED COM 73H OXY USA, INC. 2,378' FSL 1,093' FEL, SECTION 35 NAD 83, SPCS NM EAST X:723282.32' / Y:522243.50' LAT:32.43433260N / LON:103.74359946W NAD 27, SPCS NM EAST X:682100.52' / Y:522182.61' LAT:32.43421029N / LON:103.74310833W ELEVATION = 3544'</p>	<p>WELL 10 AVID DIVA 35_11 FED COM 74H OXY USA, INC. 2,377' FSL 1,063' FEL, SECTION 35 NAD 83, SPCS NM EAST X:723312.37' / Y:522243.43' LAT:32.43433196N / LON:103.74350206W NAD 27, SPCS NM EAST X:682130.57' / Y:522182.53' LAT:32.43420964N / LON:103.74301094W ELEVATION = 3544'</p>	<p>WELL 11 AVID DIVA 35_11 FED COM 35H OXY USA, INC. 2,377' FSL 1,003' FEL, SECTION 35 NAD 83, SPCS NM EAST X:723372.32' / Y:522243.40' LAT:32.43433096N / LON:103.74330775W NAD 27, SPCS NM EAST X:682190.52' / Y:522182.51' LAT:32.43420864N / LON:103.74281664W ELEVATION = 3544'</p>	<p>WELL 12 AVID DIVA 35_11 FED COM 36H OXY USA, INC. 2,377' FSL 973' FEL, SECTION 35 NAD 83, SPCS NM EAST X:723402.38' / Y:522243.41' LAT:32.43433052N / LON:103.74321033W NAD 27, SPCS NM EAST X:682220.58' / Y:522182.52' LAT:32.43420820N / LON:103.74271922W ELEVATION = 3537'</p>
<p>WELL 13 AVID DIVA 35_11 FED COM 37H OXY USA, INC. 2,377' FSL 943' FEL, SECTION 35 NAD 83, SPCS NM EAST X:723432.29' / Y:522243.46' LAT:32.43433020N / LON:103.74311338W NAD 27, SPCS NM EAST X:682250.49' / Y:522182.56' LAT:32.43420788N / LON:103.75262227W ELEVATION = 3538'</p>	<p>WELL 14 AVID DIVA 35_11 FED COM 38H OXY USA, INC. 2,377' FSL 913' FEL, SECTION 35 NAD 83, SPCS NM EAST X:723462.38' / Y:522243.42' LAT:32.43432964N / LON:103.74301586W NAD 27, SPCS NM EAST X:682280.58' / Y:522182.53' LAT:32.43420732N / LON:103.74252476W ELEVATION = 3538'</p>		

12/21/2023	01/18/2024
DATE SURVEYED	DATE DRAWN

I, DAVID W. MYERS, NEW MEXICO PROFESSIONAL SURVEYOR NO. 11403 DO HEREBY CERTIFY THAT THIS EASEMENT SURVEY PLAT AND THE ACTUAL SURVEY ON THE GROUND UPON WHICH IT IS BASED WERE PERFORMED BY ME OR UNDER MY DIRECT SUPERVISION; THAT I AM RESPONSIBLE FOR THIS SURVEY; THAT THIS SURVEY MEETS THE MINIMUM STANDARDS FOR SURVEYING IN NEW MEXICO; AND THAT IT IS TRUE AND CORRECT TO THE BEST OF MY KNOWLEDGE AND BELIEF. I FURTHER CERTIFY THAT THIS SURVEY IS NOT A LAND DIVISION OR SUBDIVISION AS DEFINED IN THE NEW MEXICO SUBDIVISION ACT AND THAT THIS INSTRUMENT IS AN EASEMENT SURVEY PLAT CROSSING AN EXISTING TRACT OR TRACTS.

0	01/18/2024	ANC
REV.	DATE	BY

BASIS OF BEARING

ALL BEARINGS AND COORDINATES REFER TO NAD 83, NEW MEXICO STATE PLANE COORDINATE SYSTEM, EAST ZONE, U.S. SURVEY FEET. ALL BEARINGS, DISTANCES, COORDINATES AND AREAS ARE GRID MEASUREMENTS UTILIZING A COMBINED SCALE FACTOR OF 0.999777483 AND A CONVERGENCE ANGLE OF 0.313558824°.

LEGEND	
	EXISTING ROAD
	PROPOSED ROAD
	SURFACE SITE EDGE
	EXIST. PIPELINE
	MONUMENT
	QUARTER SPLIT
	OHP OVERHEAD POWER FENCE
	SECTION LINE
	PROPERTY LINE
	WATER LINE
	SALT WATER LINE

JANUARY 19, 2024

DAVID W. MYERS
 11403
 PROFESSIONAL SURVEYOR
 DAVID W. MYERS 11403



PREPARED BY:
 DELTA FIELD SERVICES, LLC
 510 TRENTON ST.
 WEST MONROE, LA 71291
 318-323-6900 OFFICE
 JOB No. R4223_008
 SHEET 5 OF 5



10M Choke Panel

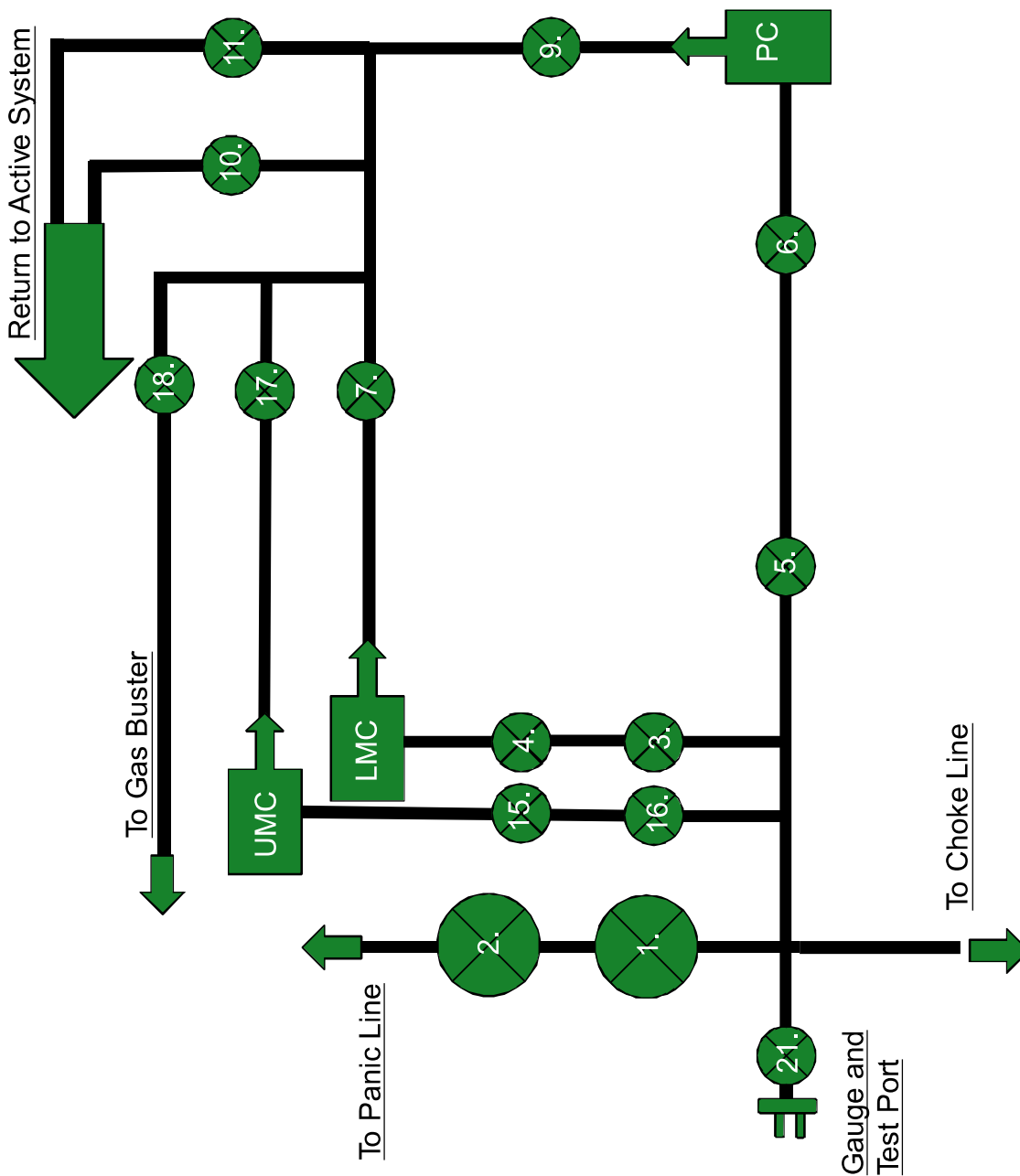

- 1. Choke Manifold Valve
- 2. Choke Manifold Valve
- 3. Choke Manifold Valve
- 4. Choke Manifold Valve
- 5. Choke Manifold Valve
- 6. Choke Manifold Valve
- 7. Choke Manifold Valve

8. **PC – Power Choke**

- 9. Choke Manifold Valve
- 10. Choke Manifold Valve
- 11. Choke Manifold Valve

12. **LMC – Lower Manual Choke**

13. **UMC – Upper manual choke**

- 15. Choke Manifold Valve
- 16. Choke Manifold Valve
- 17. Choke Manifold Valve
- 18. Choke Manifold Valve

21. Vertical Choke Manifold Valve

***All Valves 3" minimum**

10M REMOTE KILL LINE SCHEMATIC

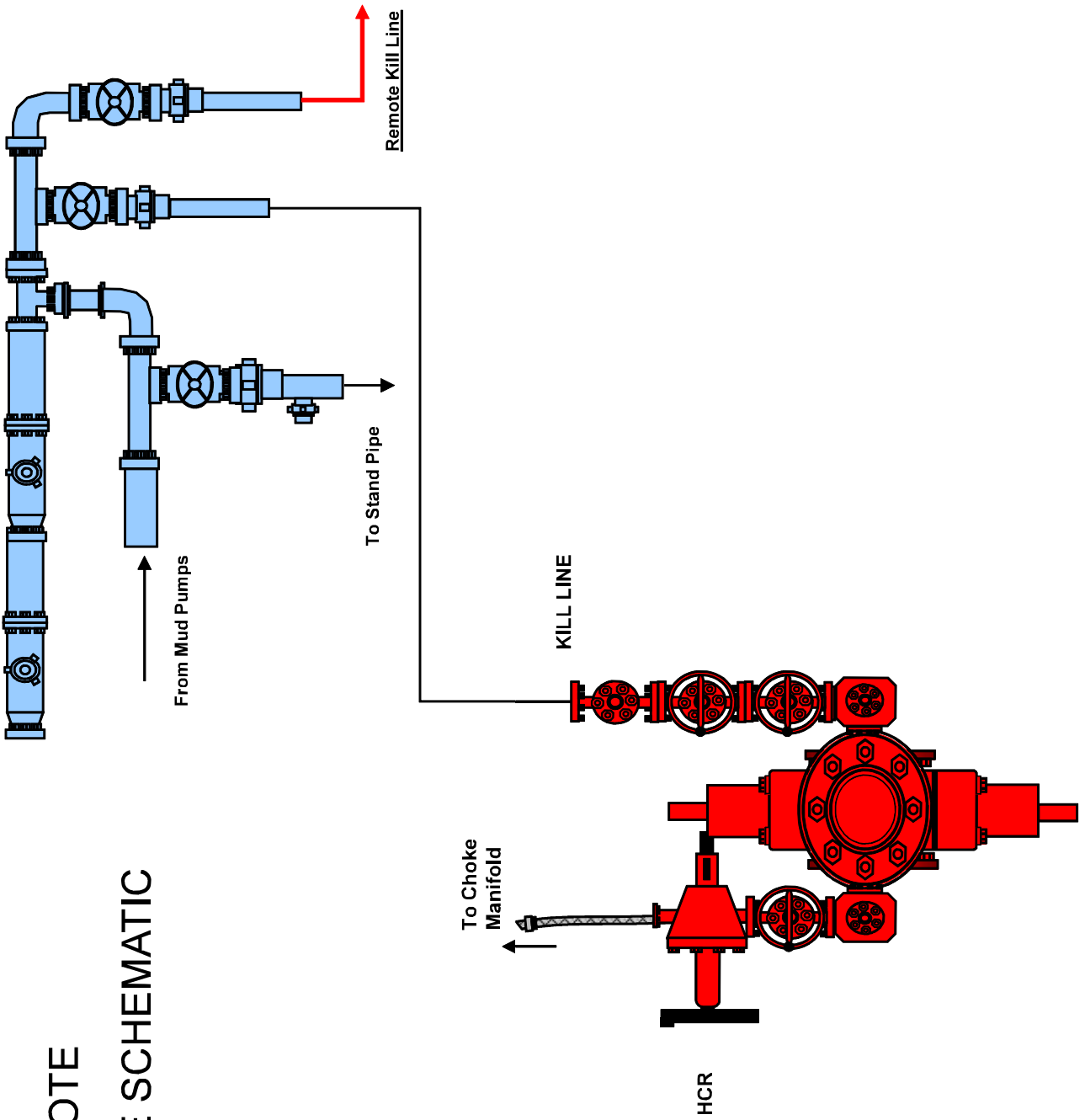

Choke Manifold – Gas Separator (Top View)

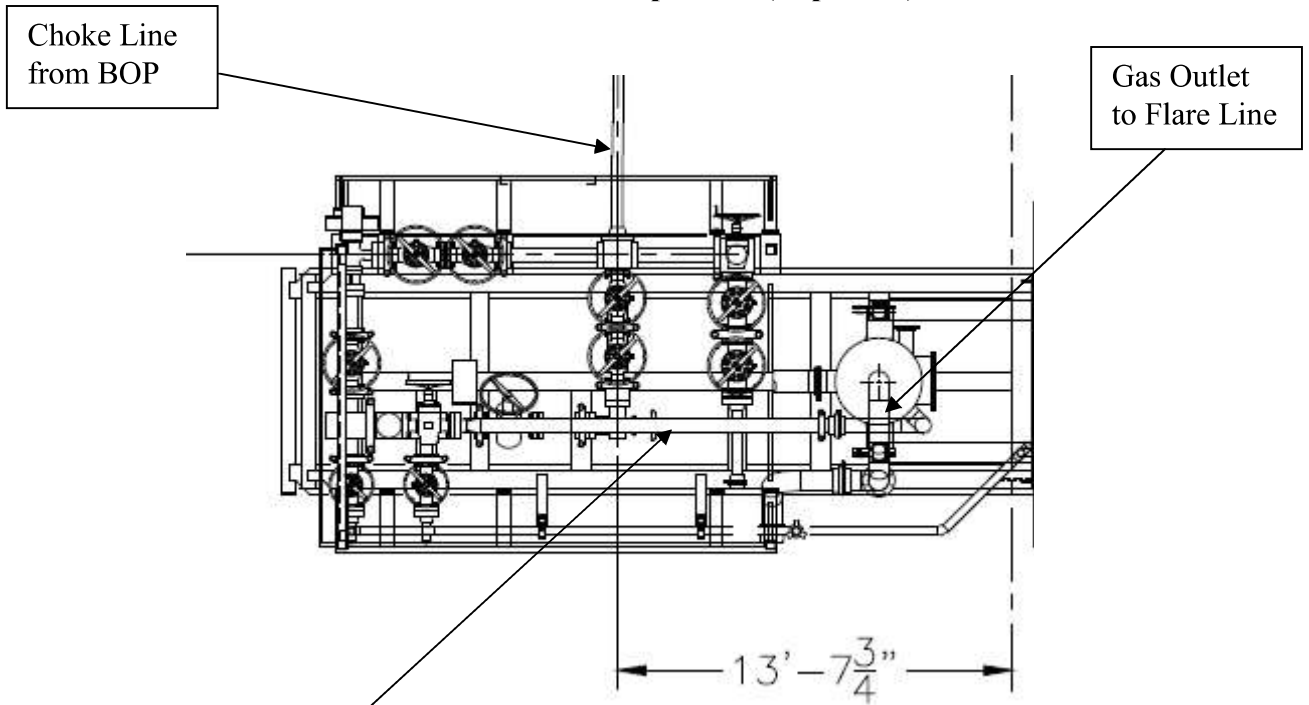

Choke Manifold – Gas Separator (Side View)

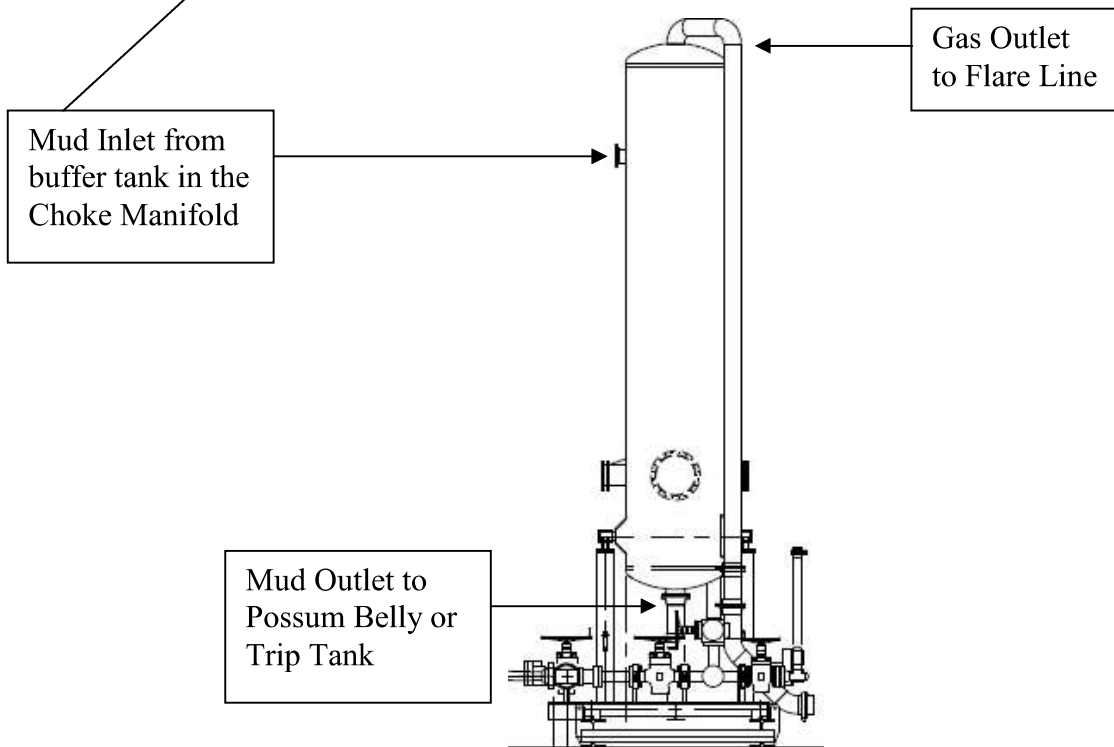

5/10M BOP Stack

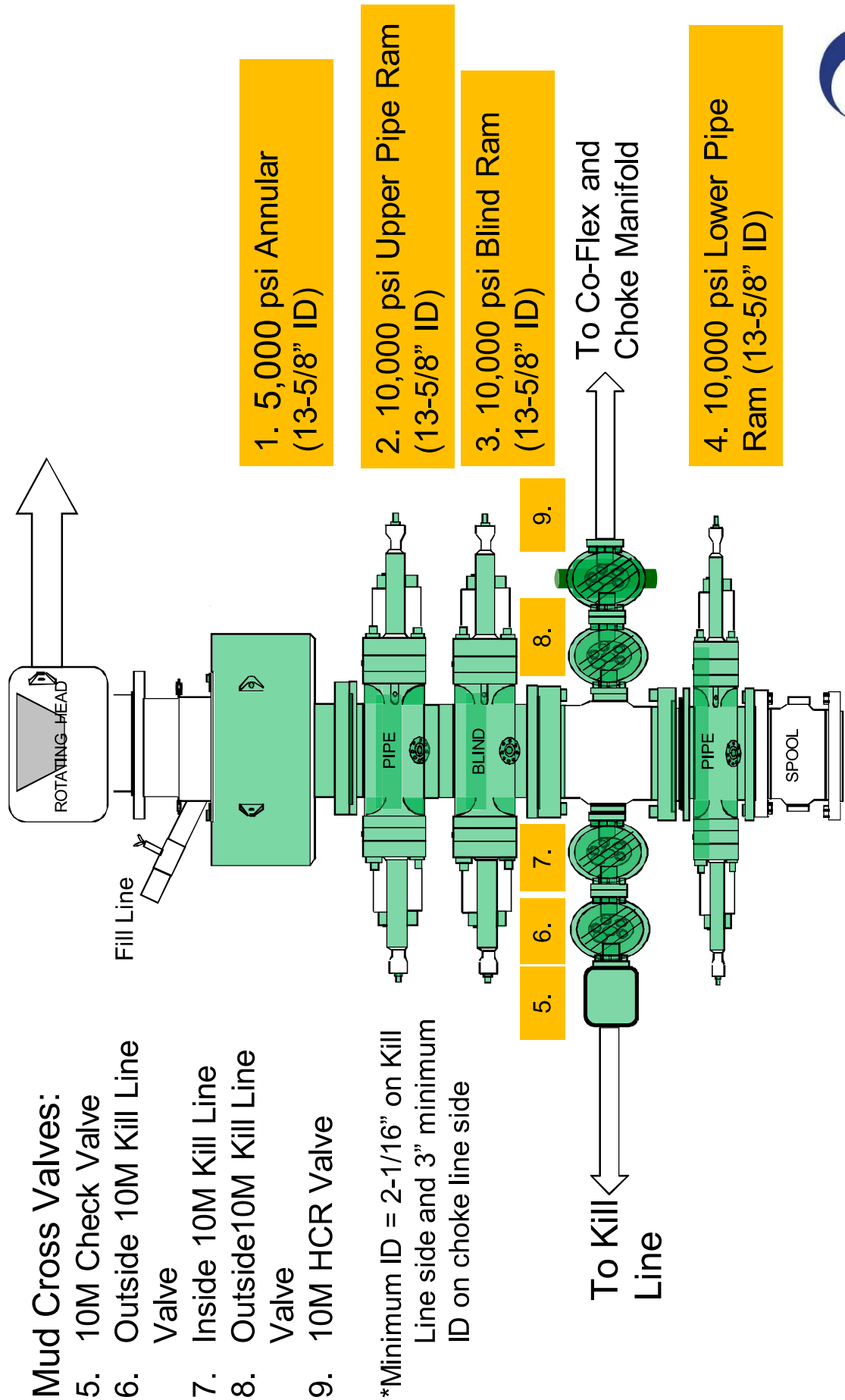

Sante Fe Main Office
Phone: (505) 476-3441

General Information
Phone: (505) 629-6116

Online Phone Directory
<https://www.emnrd.nm.gov/ocd/contact-us>

State of New Mexico
Energy, Minerals and Natural Resources
Oil Conservation Division
1220 S. St Francis Dr.
Santa Fe, NM 87505

ACKNOWLEDGMENTS

Action 485681

ACKNOWLEDGMENTS

Operator: OXY USA INC P.O. Box 4294 Houston, TX 772104294	OGRID: 16696
	Action Number: 485681
	Action Type: [C-101] BLM - Federal/Indian Land Lease (Form 3160-3)

ACKNOWLEDGMENTS

<input type="checkbox"/>	I hereby certify that no additives containing PFAS chemicals will be added to the completion or recompletion of this well.
--------------------------	--

Sante Fe Main Office
Phone: (505) 476-3441

General Information
Phone: (505) 629-6116

Online Phone Directory
<https://www.emnrd.nm.gov/oecd/contact-us>

State of New Mexico
Energy, Minerals and Natural Resources
Oil Conservation Division
1220 S. St Francis Dr.
Santa Fe, NM 87505

CONDITIONS

Action 485681

CONDITIONS

Operator: OXY USA INC P.O. Box 4294 Houston, TX 772104294	OGRID: 16696
	Action Number: 485681
	Action Type: [C-101] BLM - Federal/Indian Land Lease (Form 3160-3)

CONDITIONS

Created By	Condition	Condition Date
melissaguidry	Cement is required to circulate on both surface and intermediate1 strings of casing.	7/16/2025
melissaguidry	If cement does not circulate on any string, a Cement Bond Log (CBL) is required for that string of casing.	7/16/2025
ward.rikala	Notify the OCD 24 hours prior to casing & cement.	8/24/2025
ward.rikala	File As Drilled C-102 and a directional Survey with C-104 completion packet.	8/24/2025
ward.rikala	Once the well is spud, to prevent ground water contamination through whole or partial conduits from the surface, the operator shall drill without interruption through the fresh water zone or zones and shall immediately set in cement the water protection string.	8/24/2025
ward.rikala	Oil base muds are not to be used until fresh water zones are cased and cemented providing isolation from the oil or diesel. This includes synthetic oils. Oil based mud, drilling fluids and solids must be contained in a steel closed loop system.	8/24/2025
ward.rikala	Operator must comply with all of the R-111-Q requirements.	8/24/2025