

U.S. Department of the Interior
BUREAU OF LAND MANAGEMENT

Well Name: BILBREY 34/27 H3OB FED COM	Well Location: T21S / R32E / SEC 34 / SESE / 32.4285673 / -103.6575622	County or Parish/State: LEA / NM
Well Number: 1H	Type of Well: OIL WELL	Allottee or Tribe Name:
Lease Number: NMNM558579	Unit or CA Name:	Unit or CA Number:
US Well Number: 3002553650	Operator: MEWBOURNE OIL COMPANY	

Notice of Intent

Sundry ID: 2825731

Type of Submission: Notice of Intent

Type of Action: APD Change

Date Sundry Submitted: 12/04/2024

Time Sundry Submitted: 01:42

Date proposed operation will begin: 12/04/2024

Procedure Description: Mewbourne Oil Company requests approval for the following changes to the APD API (3002553650) 1. Change the well name from Bilbrey 34/27 H3OB Fed Com 1H to Bilbrey 34/27 Fed Com 555H 2. Change BHL from 100 FNL 1420 FEL Sec 27 T21S R32E to 100 FNL 2150 FEL Sec 27 T21S R32E. 3. A variance is requested to perform BOP testing and offline cementing according to the attached procedures

NOI Attachments

Procedure Description

BILBREY_34_27_FED_COM_555H_C102_20241204134220.pdf

MOC_Offline_Cementing_Variance_20241204134156.pdf

MOC_Break_Testing_Variance_20241204134155.pdf

Well Name: BILBREY 34/27 FED COM **Well Location:** T21S / R32E / SEC 34 / SESE / 32.4285673 / -103.6575622 **County or Parish/State:** LEA / NM

Well Number: 1H **Type of Well:** OIL WELL **Allottee or Tribe Name:**

Lease Number: NMNM558579 **Unit or CA Name:** **Unit or CA Number:**

US Well Number: 3002553650 **Operator:** MEWBOURNE OIL COMPANY

Conditions of Approval

Additional

BILBREY_34_27_FED_COM_555H_Sundry_2825731_COA_20241210145256.pdf

Operator

I certify that the foregoing is true and correct. Title 18 U.S.C. Section 1001 and Title 43 U.S.C. Section 1212, make it a crime for any person knowingly and willfully to make to any department or agency of the United States any false, fictitious or fraudulent statements or representations as to any matter within its jurisdiction. Electronic submission of Sundry Notices through this system satisfies regulations requiring a

Operator Electronic Signature: BRETT MILLER

Signed on: DEC 04, 2024 01:42 PM

Name: MEWBOURNE OIL COMPANY

Title: ENGINEER

Street Address: 4801 BUSINESS PARK BLVD

City: HOBBS

State: NM

Phone: (505) 280-6768

Email address: BRETT.MILLER@MEWBOURNE.COM

Field

Representative Name:

Street Address:

City:

State:

Zip:

Phone:

Email address:

BLM Point of Contact

BLM POC Name: CHRISTOPHER WALLS

BLM POC Title: Petroleum Engineer

BLM POC Phone: 5752342234

BLM POC Email Address: CWALLS@BLM.GOV

Disposition: Approved

Disposition Date: 12/11/2024

Form 3160-5
(October 2024)

UNITED STATES
DEPARTMENT OF THE INTERIOR
BUREAU OF LAND MANAGEMENT

FORM APPROVED
OMB No. 1004-0220
Expires: October 31, 2027

SUNDRY NOTICES AND REPORTS ON WELLS
Do not use this form for proposals to drill or to re-enter an abandoned well. Use Form 3160-3 (APD) for such proposals.

5. Lease Serial No. **NMNM558579**

6. If Indian, Allottee or Tribe Name

SUBMIT IN TRIPLICATE - Other instructions on page 2

1. Type of Well
 Oil Well Gas Well Other

2. Name of Operator **MEWBOURNE OIL COMPANY**

3a. Address **P O BOX 5270, HOBBS, NM 88241**

3b. Phone No. (include area code)
(575) 393-5905

4. Location of Well (Footage, Sec., T.,R.,M., or Survey Description)
SEC 34/T21S/R32E/NMP

7. If Unit of CA/Agreement, Name and/or No.

8. Well Name and No.
BILBREY 34/27 H3OB FED COM/1H

9. API Well No. **3002553650**

10. Field and Pool or Exploratory Area
Red Tank/Bone spring

11. Country or Parish, State
LEA/NM

12. CHECK THE APPROPRIATE BOX(ES) TO INDICATE NATURE OF NOTICE, REPORT OR OTHER DATA

TYPE OF SUBMISSION	TYPE OF ACTION			
<input checked="" type="checkbox"/> Notice of Intent	<input type="checkbox"/> Acidize	<input type="checkbox"/> Deepen	<input type="checkbox"/> Production (Start/Resume)	<input type="checkbox"/> Water Shut-Off
<input type="checkbox"/> Subsequent Report	<input type="checkbox"/> Alter Casing	<input type="checkbox"/> Hydraulic Fracturing	<input type="checkbox"/> Reclamation	<input type="checkbox"/> Well Integrity
<input type="checkbox"/> Final Abandonment Notice	<input type="checkbox"/> Casing Repair	<input type="checkbox"/> New Construction	<input type="checkbox"/> Recomplete	<input type="checkbox"/> Other
	<input checked="" type="checkbox"/> Change Plans	<input type="checkbox"/> Plug and Abandon	<input type="checkbox"/> Temporarily Abandon	
	<input type="checkbox"/> Convert to Injection	<input type="checkbox"/> Plug Back	<input type="checkbox"/> Water Disposal	

13. Describe Proposed or Completed Operation: Clearly state all pertinent details, including estimated starting date of any proposed work and approximate duration thereof. If the proposal is to deepen directionally or recomplete horizontally, give subsurface locations and measured and true vertical depths of all pertinent markers and zones. Attach the Bond under which the work will be performed or provide the Bond No. on file with BLM/BIA. Required subsequent reports must be filed within 30 days following completion of the involved operations. If the operation results in a multiple completion or recompletion in a new interval, a Form 3160-4 must be filed once testing has been completed. Final Abandonment Notices must be filed only after all requirements, including reclamation, have been completed and the operator has determined that the site is ready for final inspection.)

Mewbourne Oil Company requests approval for the following changes to the APD API (3002553650)

1. Change the well name from Bilbrey 34/27 H3OB Fed Com 1H to Bilbrey 34/27 Fed Com 555H
2. Change BHL from 100 FNL 1420 FEL Sec 27 T21S R32E to 100 FNL 2150 FEL Sec 27 T21S R32E.
3. A variance is requested to perform BOP testing and offline cementing according to the attached procedures

14. I hereby certify that the foregoing is true and correct. Name (Printed/Typed)
BRETT MILLER / Ph: (505) 280-6768

Signature (Electronic Submission)

Title **ENGINEER**

Date **12/04/2024**

THE SPACE FOR FEDERAL OR STATE OFFICE USE

Approved by
CHRISTOPHER WALLS / Ph: (575) 234-2234 / Approved

Conditions of approval, if any, are attached. Approval of this notice does not warrant or certify that the applicant holds legal or equitable title to those rights in the subject lease which would entitle the applicant to conduct operations thereon.

Title **Petroleum Engineer**

Office **CARLSBAD**

Date **12/11/2024**

Title 18 U.S.C Section 1001 and Title 43 U.S.C Section 1212, make it a crime for any person knowingly and willfully to make to any department or agency of the United States any false, fictitious or fraudulent statements or representations as to any matter within its jurisdiction.

(Instructions on page 2)

GENERAL INSTRUCTIONS

This form is designed for submitting proposals to perform certain well operations and reports of such operations when completed as indicated on Federal and Indian lands pursuant to applicable Federal law and regulations. Any necessary special instructions concerning the use of this form and the number of copies to be submitted, particularly with regard to local area or regional procedures and practices, are either shown below, will be issued by or may be obtained from the local Federal office.

SPECIFIC INSTRUCTIONS

Item 4 - Locations on Federal or Indian land should be described in accordance with Federal requirements. Consult the local Federal office for specific instructions.

Item 13: Proposals to abandon a well and subsequent reports of abandonment should include such special information as is required by the local Federal office. In addition, such proposals and reports should include reasons for the abandonment; data on any former or present productive zones or other zones with present significant fluid contents not sealed off by cement or otherwise; depths (top and bottom) and method of placement of cement plugs; mud or other material placed below, between and above plugs; amount, size, method of parting of any casing, liner or tubing pulled and the depth to the top of any tubing left in the hole; method of closing top of well and date well site conditioned for final inspection looking for approval of the abandonment. If the proposal will involve **hydraulic fracturing operations**, you must comply with 43 CFR 3162.3-3, including providing information about the protection of usable water. Operators should provide the best available information about all formations containing water and their depths. This information could include data and interpretation of resistivity logs run on nearby wells. Information may also be obtained from state or tribal regulatory agencies and from local BLM offices.

NOTICES

The privacy Act of 1974 and the regulation in 43 CFR 2.48(d) provide that you be furnished the following information in connection with information required by this application.

AUTHORITY: 30 U.S.C. 181 et seq., 351 et seq., 25 U.S.C. 396; 43 CFR 3160.

PRINCIPAL PURPOSE: The information is used to: (1) Evaluate, when appropriate, approve applications, and report completion of subsequent well operations, on a Federal or Indian lease; and (2) document for administrative use, information for the management, disposal and use of National Resource lands and resources, such as: (a) evaluating the equipment and procedures to be used during a proposed subsequent well operation and reviewing the completed well operations for compliance with the approved plan; (b) requesting and granting approval to perform those actions covered by 43 CFR 3162.3-2, 3162.3-3, and 3162.3-4; (c) reporting the beginning or resumption of production, as required by 43 CFR 3162.4-1(c) and (d) analyzing future applications to drill or modify operations in light of data obtained and methods used.

ROUTINE USES: Information from the record and/or the record will be transferred to appropriate Federal, State, local or foreign agencies, when relevant to civil, criminal or regulatory investigations or prosecutions in connection with congressional inquiries or to consumer reporting agencies to facilitate collection of debts owed the Government.

EFFECT OF NOT PROVIDING THE INFORMATION: Filing of this notice and report and disclosure of the information is mandatory for those subsequent well operations specified in 43 CFR 3162.3-2, 3162.3-3, 3162.3-4.

The Paperwork Reduction Act of 1995 requires us to inform you that:

The BLM collects this information to evaluate proposed and/or completed subsequent well operations on Federal or Indian oil and gas leases.

Response to this request is mandatory.

The BLM would like you to know that you do not have to respond to this or any other Federal agency-sponsored information collection unless it displays a currently valid OMB control number.

BURDEN HOURS STATEMENT: Public reporting burden for this form is estimated to average 8 hours per response, including the time for reviewing instructions, gathering and maintaining data, and completing and reviewing the form. Direct comments regarding the burden estimate or any other aspect of this form to U.S. Department of the Interior, Bureau of Land Management (1004-0137), Bureau Information Collection Clearance Officer (WO-630), 1849 C St., N.W., Mail Stop 401 LS, Washington, D.C. 20240

Additional Information

Location of Well

0. SHL: SESE / 205 FSL / 1080 FEL / TWSP: 21S / RANGE: 32E / SECTION: 34 / LAT: 32.4285673 / LONG: -103.6575622 (TVD: 0 feet, MD: 0 feet)
PPP: SWSE / 100 FSL / 1420 FEL / TWSP: 21S / RANGE: 32E / SECTION: 34 / LAT: 32.428274 / LONG: -103.6586641 (TVD: 10930 feet, MD: 10956 feet)
PPP: SWNE / 2640 FNL / 1420 FEL / TWSP: 21S / RANGE: 32E / SECTION: 27 / LAT: 32.4497994 / LONG: -103.6586459 (TVD: 11172 feet, MD: 18879 feet)
PPP: SWSE / 0 FSL / 1420 FEL / TWSP: 21S / RANGE: 32E / SECTION: 27 / LAT: 32.4425356 / LONG: -103.6586521 (TVD: 11180 feet, MD: 16236 feet)
PPP: SWNE / 2643 FNL / 1420 FEL / TWSP: 21S / RANGE: 32E / SECTION: 34 / LAT: 32.4352685 / LONG: -103.6586582 (TVD: 11188 feet, MD: 13592 feet)
BHL: NWNE / 100 FNL / 1420 FEL / TWSP: 21S / RANGE: 32E / SECTION: 27 / LAT: 32.4567836 / LONG: -103.65864 (TVD: 11165 feet, MD: 21420 feet)

CONFIDENTIAL

PECOS DISTRICT DRILLING CONDITIONS OF APPROVAL

OPERATOR'S NAME: MEWBOURNE OIL COMPANY
WELL NAME & NO.: BILBREY 34/27 FED COM 555H
APD ID: 10400086110
LOCATION: Section 34, T.21 S., R.32 E. NMP.
COUNTY: Lea County, New Mexico ▼

*Previously known as BILBREY 34/27 H3OB FED COM 1H. Changes approved through engineering via **Sundry 2825731** on 12/10/2024. Any previous COAs not addressed within the updated COAs still apply.*

COA

H ₂ S	<input type="radio"/> No		<input checked="" type="radio"/> Yes	
Potash / WIPP	<input type="radio"/> None	<input checked="" type="radio"/> Secretary	<input type="radio"/> R-111-Q	<input type="checkbox"/> Open Annulus <input type="checkbox"/> WIPP
Cave / Karst	3-String Design: Open Production Casing Annulus			
Wellhead	<input checked="" type="radio"/> Low	<input type="radio"/> Medium	<input type="radio"/> High	<input type="radio"/> Critical
Cementing	<input type="checkbox"/> Conventional	<input checked="" type="radio"/> Multibowl	<input type="radio"/> Both	<input type="radio"/> Diverter
Special Req	<input type="checkbox"/> Primary Squeeze	<input type="checkbox"/> Cont. Squeeze	<input type="checkbox"/> EchoMeter	<input checked="" type="checkbox"/> DV Tool
Waste Prev.	<input type="checkbox"/> Capitan Reef	<input type="checkbox"/> Water Disposal	<input checked="" type="checkbox"/> COM	<input type="checkbox"/> Unit
Additional Language	<input type="checkbox"/> Self-Certification	<input type="radio"/> Waste Min. Plan	<input checked="" type="radio"/> APD Submitted prior to 06/10/2024	
	<input checked="" type="checkbox"/> Flex Hose	<input type="checkbox"/> Casing Clearance	<input type="checkbox"/> Pilot Hole	<input checked="" type="checkbox"/> Break Testing
	<input type="checkbox"/> Four-String	<input checked="" type="checkbox"/> Offline Cementing	<input type="checkbox"/> Fluid-Filled	

SEE ORIGINAL COA FOR ALL OTHER REQUIREMENTS.

Offline Cementing

Operator has been **(Approved)** to pump the proposed cement program offline in the **Surface and intermediate(s) intervals**. Offline cementing should commence within 24 hours of landing the casing for the interval. Notify the BLM 4hrs prior to the commencement of any offline cementing procedure at **Lea County: 575-689-5981**.

BOPE Break Testing Variance

- BOPE Break Testing is **ONLY** permitted for intervals utilizing a 5M BOPE or less. **(Annular preventer must be tested to a minimum of 70% of BOPE working pressure and shall be higher than the MASP.)**
- BOPE Break Testing is **NOT** permitted to drilling the production hole section.
- Variance only pertains to the intermediate hole-sections and no deeper than the

- Bone Springs formation.
- While in transfer between wells, the BOPE shall be secured by the hydraulic carrier or cradle.
 - Any well control event while drilling require notification to the BLM Petroleum Engineer (575-706-2779) prior to the commencement of any BOPE Break Testing operations.
 - A full BOPE test is required prior to drilling the first deep intermediate hole section. If any subsequent hole interval is deeper than the first, a full BOPE test will be required. (200' TVD tolerance between intermediate shoes is allowable).
 - The BLM is to be contacted (575-689-5981 Lea County) 4 hours prior to BOPE tests.
 - As a minimum, a full BOPE test shall be performed at 21-day intervals.
 - In the event any repairs or replacement of the BOPE is required, the BOPE shall test as per **43 CFR 3172**.
 - If in the event break testing is not utilized, then a full BOPE test would be conducted.

GENERAL REQUIREMENTS

The BLM is to be notified in advance for a representative to witness:

- a. Spudding well (minimum of 24 hours)
- b. Setting and/or Cementing of all casing strings (minimum of 4 hours)
- c. BOPE tests (minimum of 4 hours)

Contact Lea County Petroleum Engineering Inspection Staff:

Call the Hobbs Field Station, 414 West Taylor, Hobbs NM 88240, (575) 689-5981

1. Unless the production casing has been run and cemented or the well has been properly plugged, the drilling rig shall not be removed from over the hole without prior approval.
 - a. In the event the operator has proposed to drill multiple wells utilizing a skid/walking rig. Operator shall secure the wellbore on the current well, after installing and testing the wellhead, by installing a blind flange of like pressure rating to the wellhead and a pressure gauge that can be monitored while drilling is performed on the other well(s).
 - b. When the operator proposes to set surface casing with Spudder Rig
 - i. Notify the BLM when moving in and removing the Spudder Rig.
 - ii. Notify the BLM when moving in the 2nd Rig. Rig to be moved in within 90 days of notification that Spudder Rig has left the location.
 - iii. BOP/BOPE test to be conducted per **43 CFR 3172** as soon as 2nd Rig is rigged up on well.
2. Floor controls are required for 3M or Greater systems. These controls will be on the rig floor, unobstructed, readily accessible to the driller and will be operational at all

times during drilling and/or completion activities. Rig floor is defined as the area immediately around the rotary table; the area immediately above the substructure on which the draw works are located, this does not include the doghouse or stairway area.

3. For intervals in which cement to surface is required, cement to surface should be verified with a visual check and density or pH check to differentiate cement from spacer and drilling mud. The results should be documented in the driller's log and daily reports.

A. CASING

1. Changes to the approved APD casing program need prior approval if the items substituted are of lesser grade or different casing size or are Non-API. The Operator can exchange the components of the proposal with that of superior strength (i.e. changing from J-55 to N-80, or from 36# to 40#). Changes to the approved cement program need prior approval if the altered cement plan has less volume or strength or if the changes are substantial (i.e. Multistage tool, ECP, etc.). The initial wellhead installed on the well will remain on the well with spools used as needed.
2. Wait on cement (WOC) for Potash Areas: After cementing but before commencing any tests, the casing string shall stand cemented under pressure until both of the following conditions have been met: 1) cement reaches a minimum compressive strength of 500 psi for all cement blends of both lead and tail cement, 2) until cement has been in place at least 8 hours. WOC time will be recorded in the driller's log. The casing integrity test can be done (prior to the cement setting up) immediately after bumping the plug.
3. Wait on cement (WOC) for Water Basin: After cementing but before commencing any tests, the casing string shall stand cemented under pressure until both of the following conditions have been met: 1) cement reaches a minimum compressive strength of 500 psi at the shoe, 2) until cement has been in place at least 8 hours. WOC time will be recorded in the driller's log. See individual casing strings for details regarding lead cement slurry requirements. The casing integrity test can be done (prior to the cement setting up) immediately after bumping the plug.
4. Provide compressive strengths including hours to reach required 500 pounds compressive strength prior to cementing each casing string. Have well specific cement details onsite prior to pumping the cement for each casing string.
5. No pea gravel permitted for remedial or fall back remedial without prior authorization from the BLM engineer.
6. On that portion of any well approved for a 5M BOPE system or greater, a pressure integrity test of each casing shoe shall be performed. Formation at the

- shoe shall be tested to a minimum of the mud weight equivalent anticipated to control the formation pressure to the next casing depth or at total depth of the well. This test shall be performed before drilling more than 20 feet of new hole.
7. If hardband drill pipe is rotated inside casing, returns will be monitored for metal. If metal is found in samples, drill pipe will be pulled and rubber protectors which have a larger diameter than the tool joints of the drill pipe will be installed prior to continuing drilling operations.
 8. Whenever a casing string is cemented in the R-111-Q potash area, the NMOCD requirements shall be followed.

B. PRESSURE CONTROL

1. All blowout preventer (BOP) and related equipment (BOPE) shall comply with well control requirements as described in **43 CFR 3172**.
2. If a variance is approved for a flexible hose to be installed from the BOP to the choke manifold, the following requirements apply: The flex line must meet the requirements of API 16C. Check condition of flexible line from BOP to choke manifold, replace if exterior is damaged or if line fails test. Line to be as straight as possible with no hard bends and is to be anchored according to Manufacturer's requirements. The flexible hose can be exchanged with a hose of equal size and equal or greater pressure rating. Anchor requirements, specification sheet and hydrostatic pressure test certification matching the hose in service, to be onsite for review. These documents shall be posted in the company man's trailer and on the rig floor.
3. 5M or higher system requires an HCR valve, remote kill line and annular to match. The remote kill line is to be installed prior to testing the system and tested to stack pressure.
4. If the operator has proposed a multi-bowl wellhead assembly in the APD. The following requirements must be met:
 - i. Wellhead shall be installed by manufacturer's representatives, submit documentation with subsequent sundry.
 - ii. If the welding is performed by a third party, the manufacturer's representative shall monitor the temperature to verify that it does not exceed the maximum temperature of the seal.
 - iii. Manufacturer representative shall install the test plug for the initial BOP test.
 - iv. Whenever any seal subject to test pressure is broken, all the tests in 43 CFR 3172.6(b)(9) must be followed.
 - v. If the cement does not circulate and one-inch operations would have been possible with a standard wellhead, the well head shall be cut off, cementing operations performed and another wellhead installed.

5. The appropriate BLM office shall be notified a minimum of 4 hours in advance for a representative to witness the tests.
 - i. In a water basin, for all casing strings utilizing slips, these are to be set as soon as the crew and rig are ready and any fallback cement remediation has been done. The casing cut-off and BOP installation can be initiated four hours after installing the slips, which will be approximately six hours after bumping the plug. For those casing strings not using slips, the minimum wait time before cut-off is eight hours after bumping the plug. BOP/BOPE testing can begin after cut-off or once cement reaches 500 psi compressive strength (including lead cement), whichever is greater. However, if the float does not hold, cut-off cannot be initiated until cement reaches 500 psi compressive strength (including lead when specified).
 - ii. In potash areas, for all casing strings utilizing slips, these are to be set as soon as the crew and rig are ready and any fallback cement remediation has been done. For all casing strings, casing cut-off and BOP installation can be initiated at twelve hours after bumping the cement plug. The BOPE test can be initiated after bumping the cement plug with the casing valve open. (Only applies to single stage cement jobs, prior to the cement setting up.)
 - iii. The tests shall be done by an independent service company utilizing a test plug not a cup or J-packer and can be initiated immediately with the casing valve open. The operator also has the option of utilizing an independent tester to test without a plug (i.e. against the casing) pursuant to **43 CFR 3172** with the pressure not to exceed 70% of the burst rating for the casing. Any test against the casing must meet the WOC time for 8 hours or 500 pounds compressive strength, whichever is greater, prior to initiating the test (see casing segment as lead cement may be critical item).
 - iv. The test shall be run on a 5000-psi chart for a 2-3M BOP/BOP, on a 10000 psi chart for a 5M BOP/BOPE and on a 15000 psi chart for a 10M BOP/BOPE. If a linear chart is used, it shall be a one-hour chart. A circular chart shall have a maximum 2-hour clock. If a twelve hour or twenty-four-hour chart is used, tester shall make a notation that it is run with a two hour clock.
 - v. The results of the test shall be reported to the appropriate BLM office.
 - vi. All tests are required to be recorded on a calibrated test chart. A copy of the BOP/BOPE test chart and a copy of independent service company test will be submitted to the appropriate BLM office.
 - vii. The BOP/BOPE test shall include a low-pressure test from 250 to 300 psi. The test will be held for a minimum of 10 minutes if test is done with a test plug and 30 minutes without a test plug. This test shall be performed prior to the test at full stack pressure.

- viii. BOP/BOPE must be tested by an independent service company within 500 feet of the top of the Wolfcamp formation if the time between the setting of the intermediate casing and reaching this depth exceeds 20 days. This test does not exclude the test prior to drilling out the casing shoe as per **43 CFR 3172**.

C. DRILLING MUD

Mud system monitoring equipment, with derrick floor indicators and visual and audio alarms, shall be operating before drilling into the Wolfcamp formation, and shall be used until production casing is run and cemented.

D. WASTE MATERIAL AND FLUIDS

All waste (i.e. drilling fluids, trash, salts, chemicals, sewage, gray water, etc.) created as a result of drilling operations and completion operations shall be safely contained and disposed of properly at a waste disposal facility. No waste material or fluid shall be disposed of on the well location or surrounding area. Porto-johns and trash containers will be on-location during fracturing operations or any other crew-intensive operations.

SA 12/10/2024

ACREAGE DEDICATION PLATS

This grid represents a standard section. You may superimpose a non-standard section, or larger area, over this grid. Operators must outline the dedicated acreage in a red box, clearly show the well surface location and bottom hole location, if it is a directionally drilled, with the dimensions from the section lines in the cardinal directions. If this is a horizontal wellbore show on this plat the location of the First Take Point and Last Take Point, and the point within the Completed interval (other than the First Take Point or Last Take Point) that is closest to any outer boundary of the tract.

Surveyors shall use the latest United States government survey or dependent resurvey. Well locations will be in reference to the New Mexico Principal Meridian. If the land is not surveyed, contact the OCD Engineering Bureau. Independent subdivision surveys will not be acceptable.

BILBREY 34/27 FED COM #555H

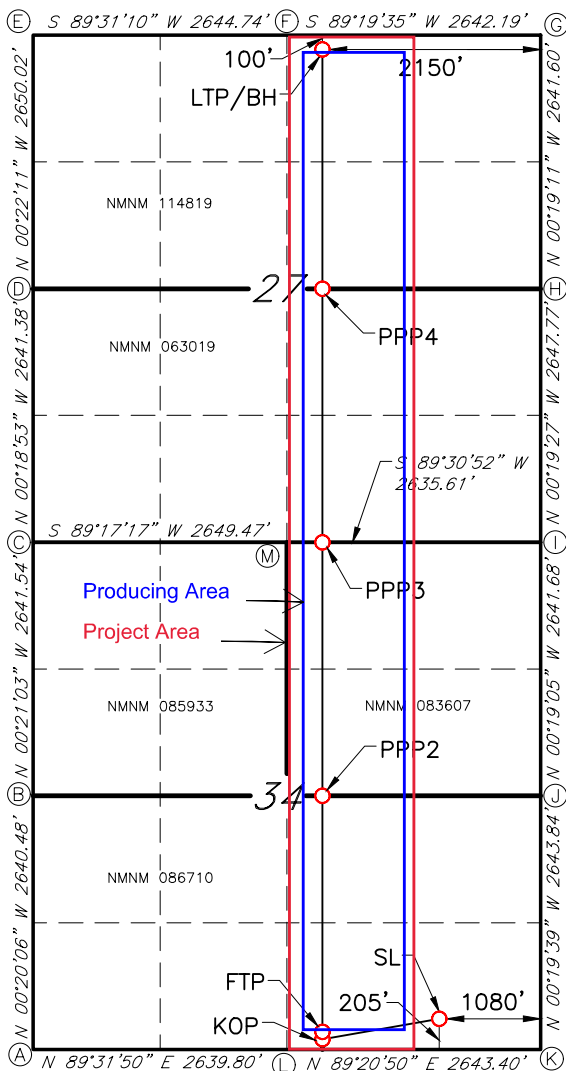

GEODETTIC DATA
NAD 83 GRID - NM EAST

SURFACE LOCATION (SL)
N: 520303.3 - E: 749840.3
LAT: 32.4285673° N
LONG: 103.6575621° W

KICK OFF POINT (KOP)
10' FSL & 2150' FEL (SEC.34)
N: 520096.1 - E: 748772.0
LAT: 32.4280164° N
LONG: 103.6610287° W

FIRST TAKE POINT (FTP)
100' FSL & 2150' FEL (SEC.34)
N: 520186.1 - E: 748771.5
LAT: 32.4282638° N
LONG: 103.6610285° W

PROPOSED PENETRATION POINT 2 (PPP2)
2646' FSL & 2150' FEL (SEC.34)
N: 522731.4 - E: 748757.2
LAT: 32.4352601° N
LONG: 103.6610230° W

PROPOSED PENETRATION POINT 3 (PPP3)
0' FSL & 2150' FEL (SEC.27)
N: 525376.7 - E: 748742.3
LAT: 32.4425313° N
LONG: 103.6610172° W

PROPOSED PENETRATION POINT 4 (PPP4)
2641' FSL & 2150' FEL (SEC.27)
N: 528017.0 - E: 748727.4
LAT: 32.4497887° N
LONG: 103.6610115° W

LAST TAKE POINT/BOTTOM HOLE (LTP/BH)
N: 530557.8 - E: 748713.2
LAT: 32.4567727° N
LONG: 103.6610060° W

CORNER DATA
NAD 83 GRID - NM EAST

- | | |
|--|--|
| A: FOUND BRASS CAP "1916"
N: 520058.9 - E: 745639.7 | H: FOUND BRASS CAP "1916"
N: 528042.1 - E: 750876.7 |
| B: FOUND BRASS CAP "1916"
N: 522698.8 - E: 745624.2 | I: FOUND BRASS CAP "1916"
N: 525394.9 - E: 750891.7 |
| C: FOUND BRASS CAP "1916"
N: 525339.7 - E: 745608.1 | J: FOUND BRASS CAP "1916"
N: 522753.9 - E: 750906.4 |
| D: FOUND BRASS CAP "1916"
N: 527980.4 - E: 745593.6 | K: FOUND BRASS CAP "1916"
N: 520110.6 - E: 750921.5 |
| E: FOUND BRASS CAP "1916"
N: 530629.8 - E: 745576.5 | L: FOUND BRASS CAP "1916"
N: 520080.5 - E: 748278.8 |
| F: FOUND BRASS CAP "1916"
N: 530652.0 - E: 748220.5 | M: FOUND BRASS CAP "1916"
N: 525372.6 - E: 748256.8 |
| G: FOUND BRASS CAP "1916"
N: 530683.1 - E: 750862.0 | |



Mewbourne Oil Co.

Surface & Intermediate Offline Cementing Variance

Mewbourne Oil Company requests a variance to perform offline cementing for surface and intermediate casing strings with the following conditions:

- Offline cementing will not be performed on production casing.
- Offline cementing will not be performed on a hole section with MASP > 5000 psi.
- Offline cementing will not be performed concurrently with offset drilling.

Surface Casing Order of Operations:

1. Run 13 3/8" surface casing as per normal operations (TPGS and float collar).
2. Perform negative pressure test to confirm integrity of float equipment while running casing.
3. Confirm well is static.
4. Make up 13 5/8" wellhead or wellhead landing ring assembly and land on 20" conductor.
5. Fill pipe, circulate casing capacity and confirm float(s) are still holding.
6. Confirm well is static.
7. Back out landing joint and pull to rig floor. Lay down landing joint.
8. Walk rig to next well on pad with cement crew standing by to rig up.
9. Make up offline cement tool with forklift per wellhead manufacturer (Fig. 1 & 2).
10. Make up cement head on top of offline cement tool with forklift.
11. Commence cement operations.
12. If cement circulates, confirm well is static and proceed to step 16.
13. If cement does not circulate, notify the appropriate BLM office, wait a minimum of six hours, and run a temperature survey to determine the top of cement.
14. Use 1" pipe for remedial cement job until the surface casing is cemented to surface.
15. Confirm well is static.
16. Once cement job is complete, the cement head and offline cementing tool are removed. The wellhead technician returns to cellar to install wellhead/valves.
17. Install wellhead capping flange.

Barriers

Before Walk:

- Float(s) in casing
- Kill weight fluid in casing
- Kill weight fluid in annulus



After Walk:

- Float(s) in casing
- Kill weight fluid in casing
- Kill weight fluid in annulus
- Offline cementing tool tested to 5000 psi and cement head
- Capping flange after cementing

20" Surface Casing Order of Operations (4 string area):

1. Run 20" surface casing as per normal operations (TPGS and float collar).
2. Perform negative pressure test to confirm integrity of float equipment while running casing.
3. Fill pipe, circulate casing capacity and confirm float(s) are still holding.
4. Confirm well is static.
5. Back out landing joint and pull to rig floor. Lay down landing joint.
6. Make up cement head.
7. Walk rig to next well on pad with cement crew standing by to rig up.
8. Commence cement operations.
9. If cement circulates, confirm well is static and proceed to step 13.
10. If cement does not circulate, notify the appropriate BLM office, wait a minimum of six hours, and run a temperature survey to determine the top of cement.
11. Use 1" pipe for remedial cement job until the surface casing is cemented to surface.
12. Confirm well is static.
13. Once cement job is complete, remove cement head and install cap.

Barriers

Before Walk:

- Float(s) in casing
- Kill weight fluid in casing
- Kill weight fluid in annulus
- Cement Head

After Walk:

- Float(s) in casing
- Kill weight fluid in casing
- Kill weight fluid in annulus
- Cement head
- Capping flange after cementing



Intermediate Casing Order of Operations:

1. Run casing as per normal operations (float shoe and float collar).
2. Perform negative pressure test to confirm integrity of float equipment while running casing.
3. Confirm well is static (if running SBM).
4. Land casing.
5. Fill pipe, circulate casing capacity and confirm floats are still holding.
6. Confirm well is static.
7. Back out landing joint and pull to rig floor. Lay down landing joint. Install packoff & test.
8. Nipple down BOP.
9. Walk rig to next well on pad with cement crew standing by to rig up.
10. Make up offline cement tool using forklift per wellhead manufacturer (Fig. 3 - 8).
11. Make up cement head on top of offline cement tool.
12. Commence cement operations.
13. If cement circulates, confirm well is static and proceed to step 16.
14. If cement does not circulate (when required), notify the appropriate BLM office, wait a minimum of six hours, and run a temperature survey to determine the top of cement.
15. Pump remedial cement job if required.
16. Confirm well is static.
17. Remove cement head and offline cementing tool.
18. Install wellhead capping flange and test.

Barriers

Before Nipple Down:

- Floats in casing
- Kill weight fluid in casing
- Kill weight fluid in annulus
- Solid body mandrel and/or packoff

After Nipple Down:

- Floats in casing
- Kill weight fluid in casing
- Kill weight fluid in annulus
- Solid body mandrel and/or packoff
- Offline cementing tool tested to 5000 psi and cement head
- Capping flange after cementing



Risks:

- Pressure build up in annulus before cementing
 - Contact BLM if a well control event occurs.
 - Rig up 3rd party pump or rig pumps to pump down casing and kill well.
 - Returns will be taken through the wellhead valves to a choke manifold (Fig 9 & 10).
 - Well could also be killed through the wellhead valves down the annulus.

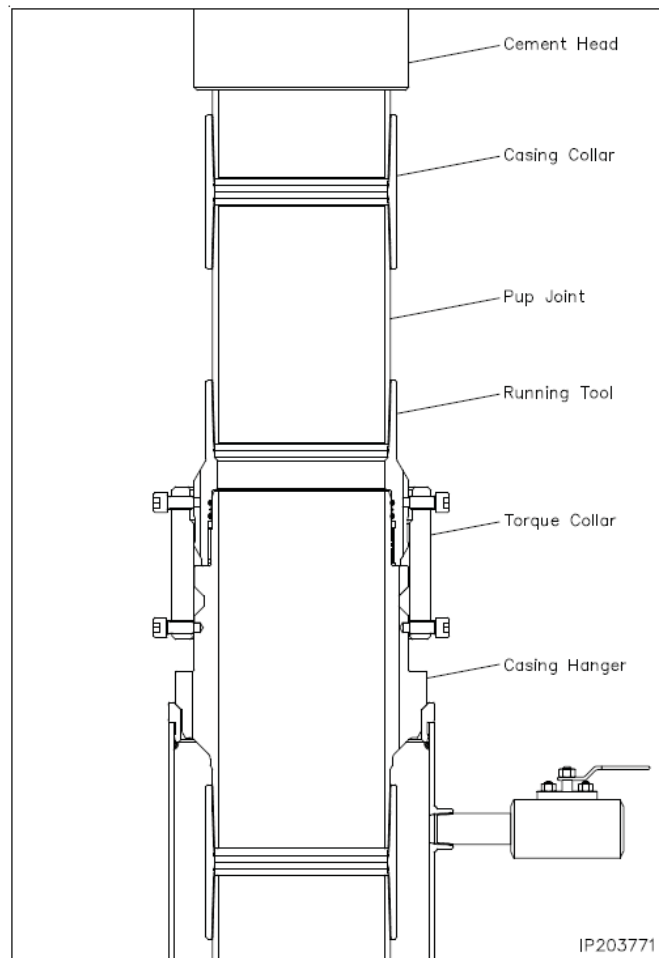

Figure 1. Cactus 13 3/8" 5M offline cementing tool. Pressure rating limited by the lesser of 5M tool rating or the 13 3/8" pup joint and casing.

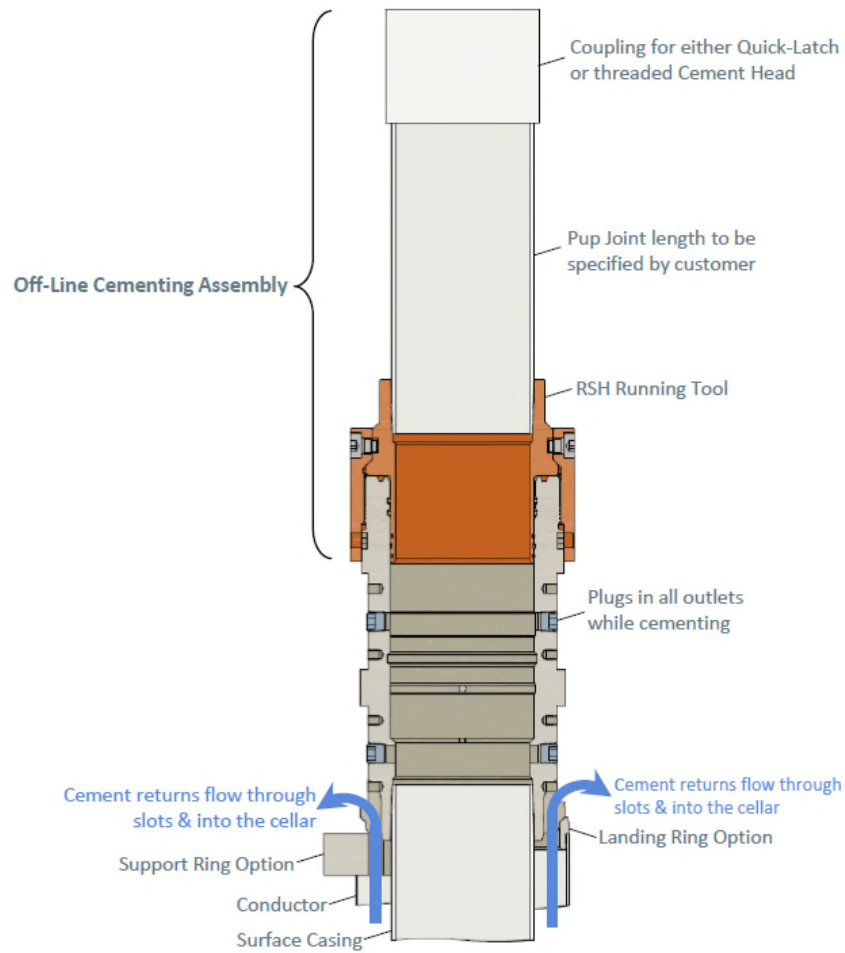

Figure 2. Vault 13 3/8" 5M offline cementing tool. Pressure rating limited by the lesser of 5M tool rating or the 13 3/8" pup joint and casing.

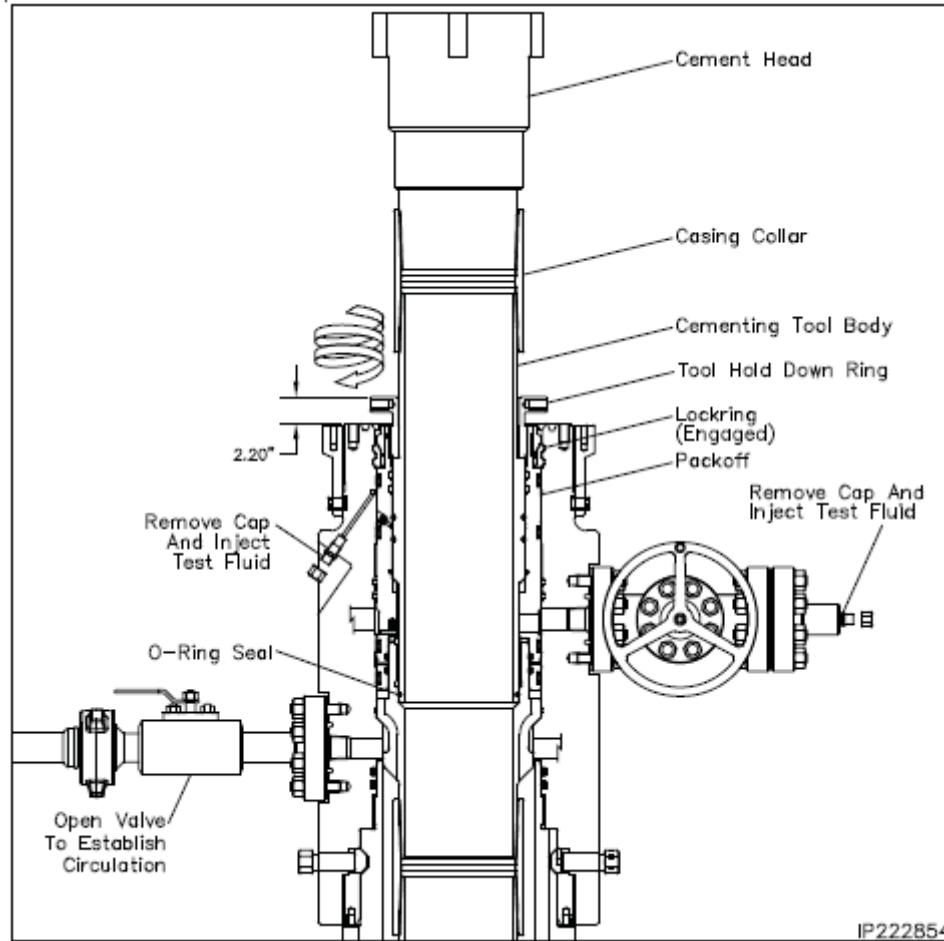

Figure 3. Cactus 9 5/8" 5M offline cementing tool. Pressure rating limited by the lesser of 5M tool rating or the 9 5/8" pup joint and casing.

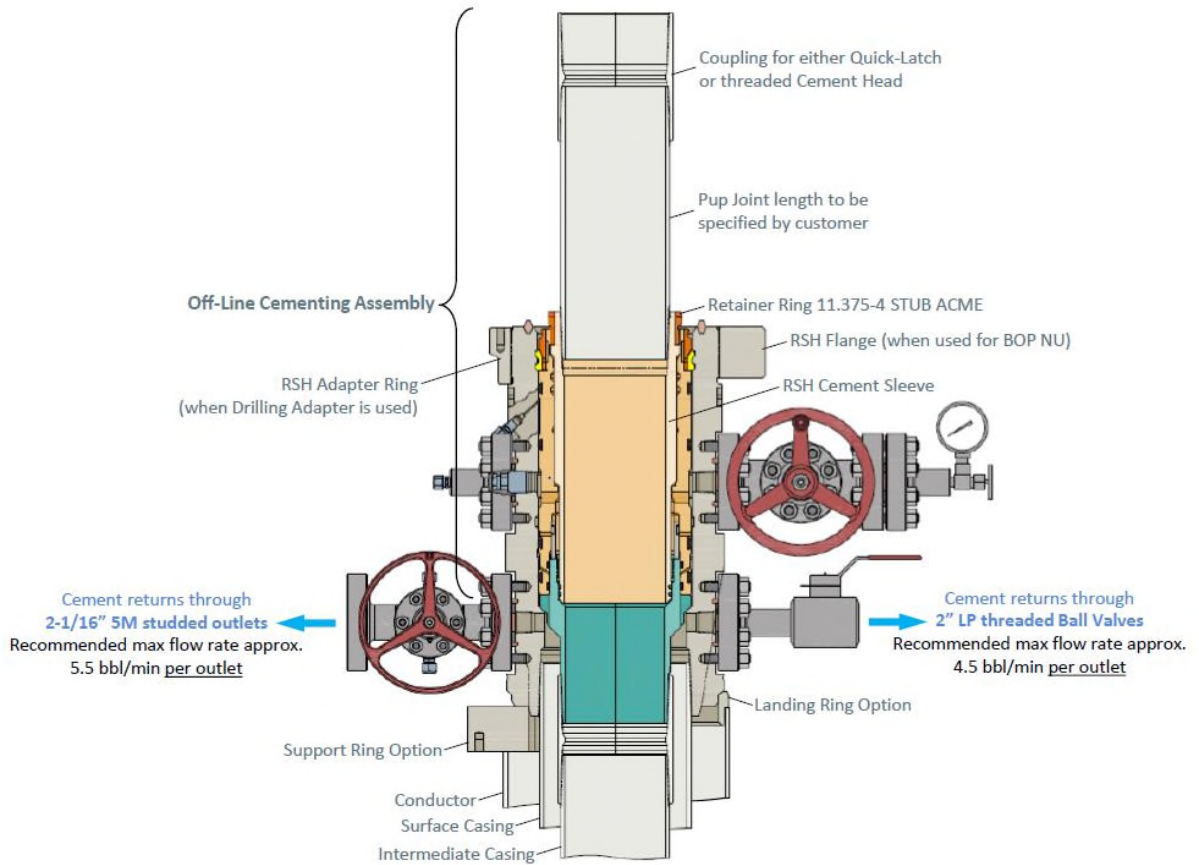

Figure 4. Vault 9 5/8" 5M offline cementing tool. Pressure rating limited by the lesser of 5M tool rating or the 9 5/8" pup joint and casing.

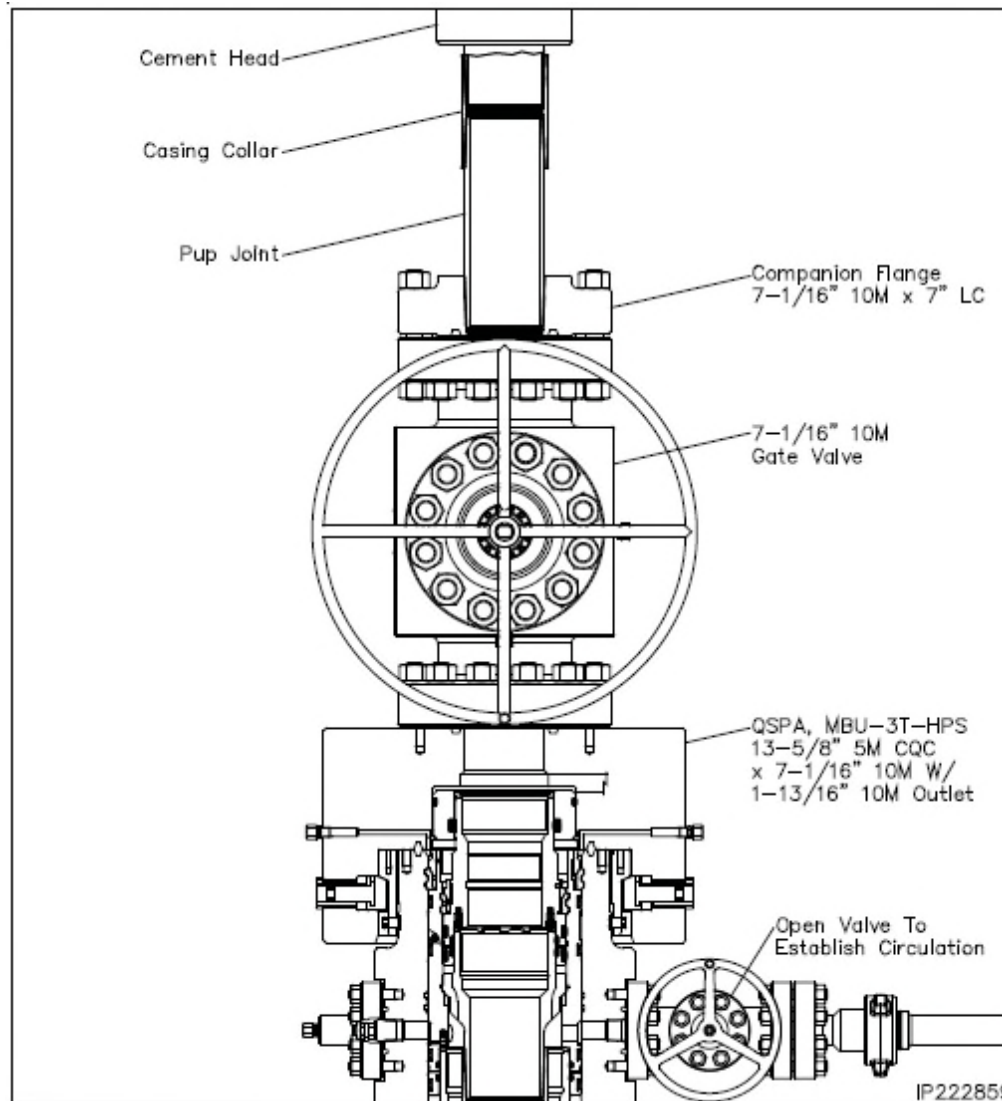

Figure 5. Cactus 7" 5M offline cementing tool. Pressure rating limited by the lesser of 5M tool rating or the 7" pup joint and casing.

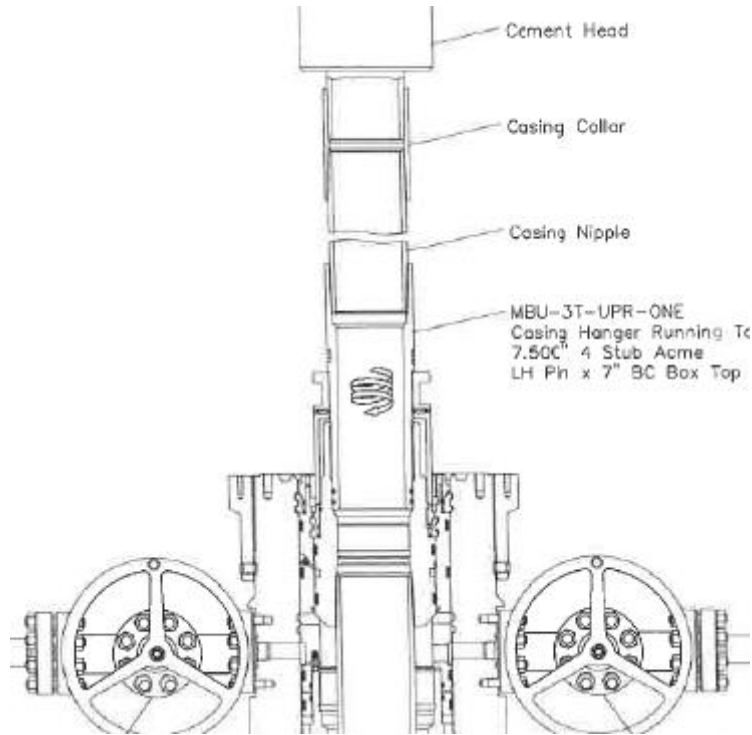

Figure 6. Cactus 7" 5M offline cementing tool. Pressure rating limited by the lesser of 5M tool rating or the 7" pup joint and casing.

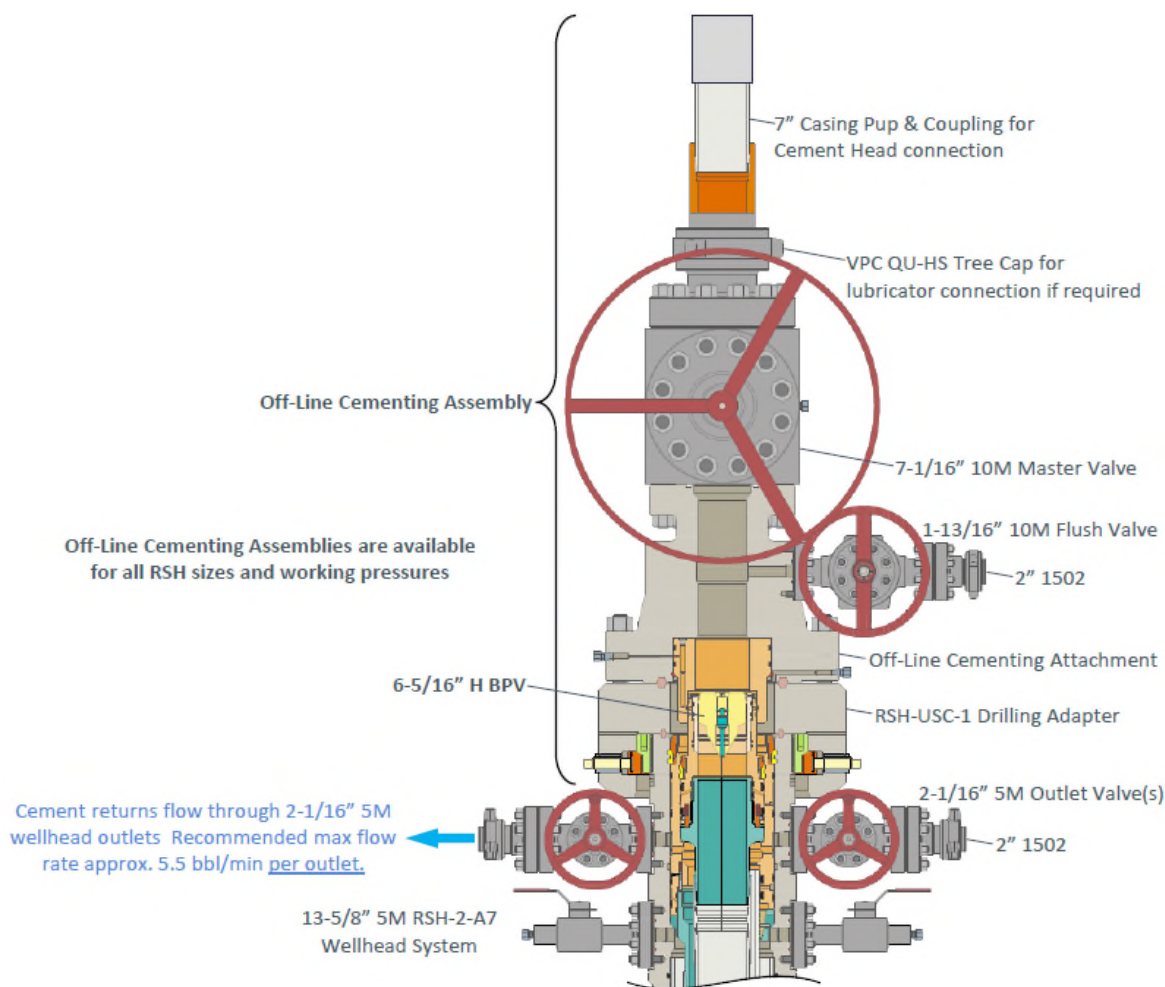

Figure 7. Vault 7" 5M offline cementing tool. Pressure rating limited by the lesser of 5M tool rating or the 7" pup joint and casing.

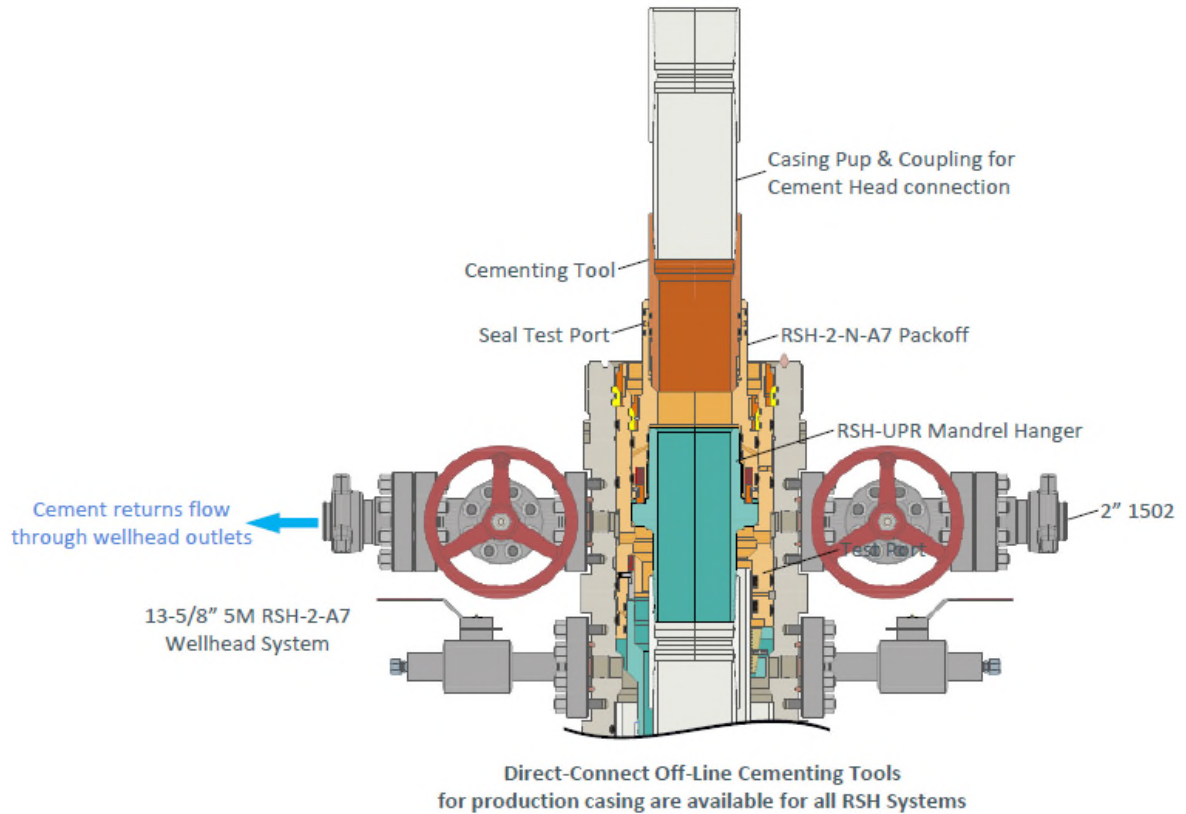

Figure 8. Vault 7" 5M offline cementing tool. Pressure rating limited by the lesser of 5M tool rating or the 7" pup joint and casing.

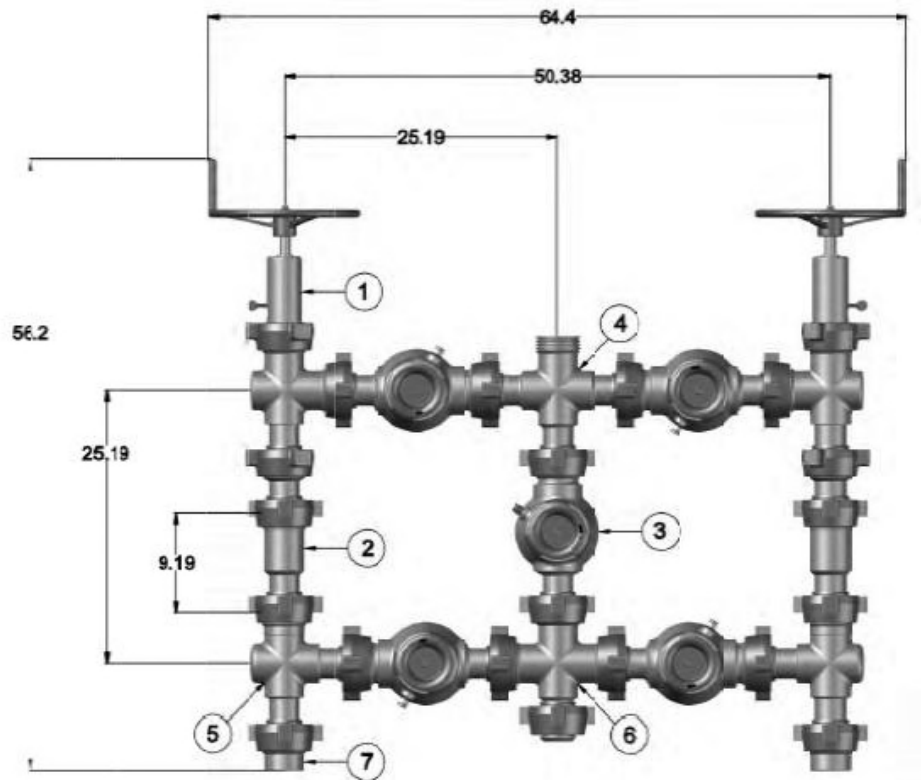

Figure 9. Five valve 15k choke manifold.

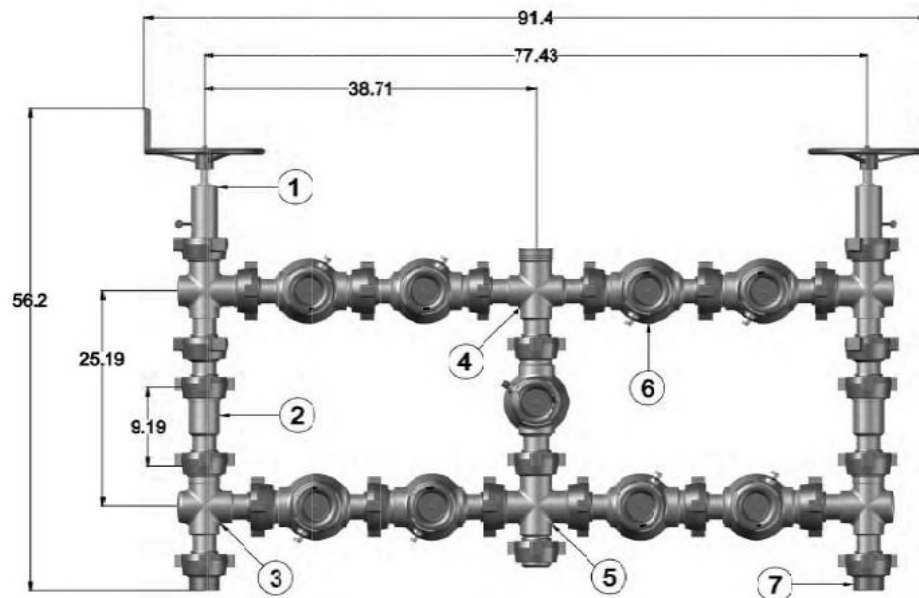

Figure 10. Nine valve 15k choke manifold.



Mewbourne Oil Co.

BOP Break Testing Variance

Mewbourne Oil Company requests a variance from the minimum standards for well control equipment testing of 43 CFR 3172 to allow a testing schedule of the blow out preventer (BOP) and blow out prevention equipment (BOPE) along with batch drilling & offline cementing operations. Modern rig upgrades which facilitate pad drilling allow the BOP stack to be moved between wells on a multi-well pad without breaking any BOP stack components apart. Widespread use of these technologies has led to break testing BOPE being endorsed as safe and reliable. American Petroleum Institute (API) best practices are frequently used by regulators to develop their regulations. API Standard 53, *Well Control Equipment Systems for Drilling Wells* (5th Ed., Dec. 2018) Section 5.3.7.1 states "A pressure test of the pressure containing component shall be performed following the disconnection or repair, limited to the affected component."

Procedures

1. Full BOPE test at first installation on the pad.
 - Full BOPE test at least every 21 days.
 - Function test BOP elements per 43 CFR 3172.
 - Contact the BLM if a well control event occurs.
2. After the well section is secured and the well is confirmed to be static, the BOP will be disconnected from the wellhead and walked with the rig to another well on the pad. Two breaks on the BOPE will be made (Fig. 1).
 - Connection between the flex line and the HCR valve
 - Connection between the wellhead and the BOP quick connect (Fig. 5 & 6).
3. A capping flange will be installed after cementing per wellhead vendor procedure & casing pressure will be monitored via wellhead valve.
4. The BOP will be removed and carried by a hydraulic carrier (Fig. 3 & 4).
5. The rig will then walk to the next well.
6. Confirm that the well is static and remove the capping flange.
7. The connection between the flex line and HCR valve and the connection between the wellhead and the BOP quick connect will be reconnected.
8. Install a test plug into the wellhead.
9. A test will then be conducted against the upper pipe rams and choke, testing both breaks (Fig. 1 & 2).
10. The test will be held at 250 psi low and to the high value submitted in the APD, not to exceed 5000 psi.
11. The annular, blind rams and lower pipe rams will then be function tested.
12. If a pad consists of three or more wells, steps 4 through 11 will be repeated.



13. A break test will only be conducted if the intermediate section can be drilled and cased within 21 days of the last full BOPE test.

Barriers

Before Nipple Down:

- Floats in casing
- Kill weight fluid in casing
- Kill weight fluid in annulus
- Solid body mandrel and/or packoff

After Nipple Down:

- Floats in casing
- Kill weight fluid in casing
- Kill weight fluid in annulus
- Solid body mandrel and/or packoff
- Offline cementing tool and/or cement head
- Capping flange after cementing

Summary

A variance is requested to only test broken pressure seals on the BOPE when moving between wells on a multi-well pad if the following conditions are met:

- A full BOPE test is conducted on the first well on the pad. API Standard 53 requires testing annular BOP to 70% of RWP or 100% of MASP, whichever is greater.
- If the first well on the pad is not the well with the deepest intermediate section, a full BOPE test will also be performed when moving to a deeper well.
- The hole section being drilled has a MASP under 5000 psi.
- If a well control event occurs, Mewbourne will contact BLM for permission to continue break testing.
- If significant (>50%) losses occur, full BOPE testing will be required going forward.
- Full BOPE test will be required prior to drilling the production hole.

While walking the rig, the BOP stack will be secured via hydraulic winch or hydraulic carrier. A full BOPE test will be performed at least every 21 days.

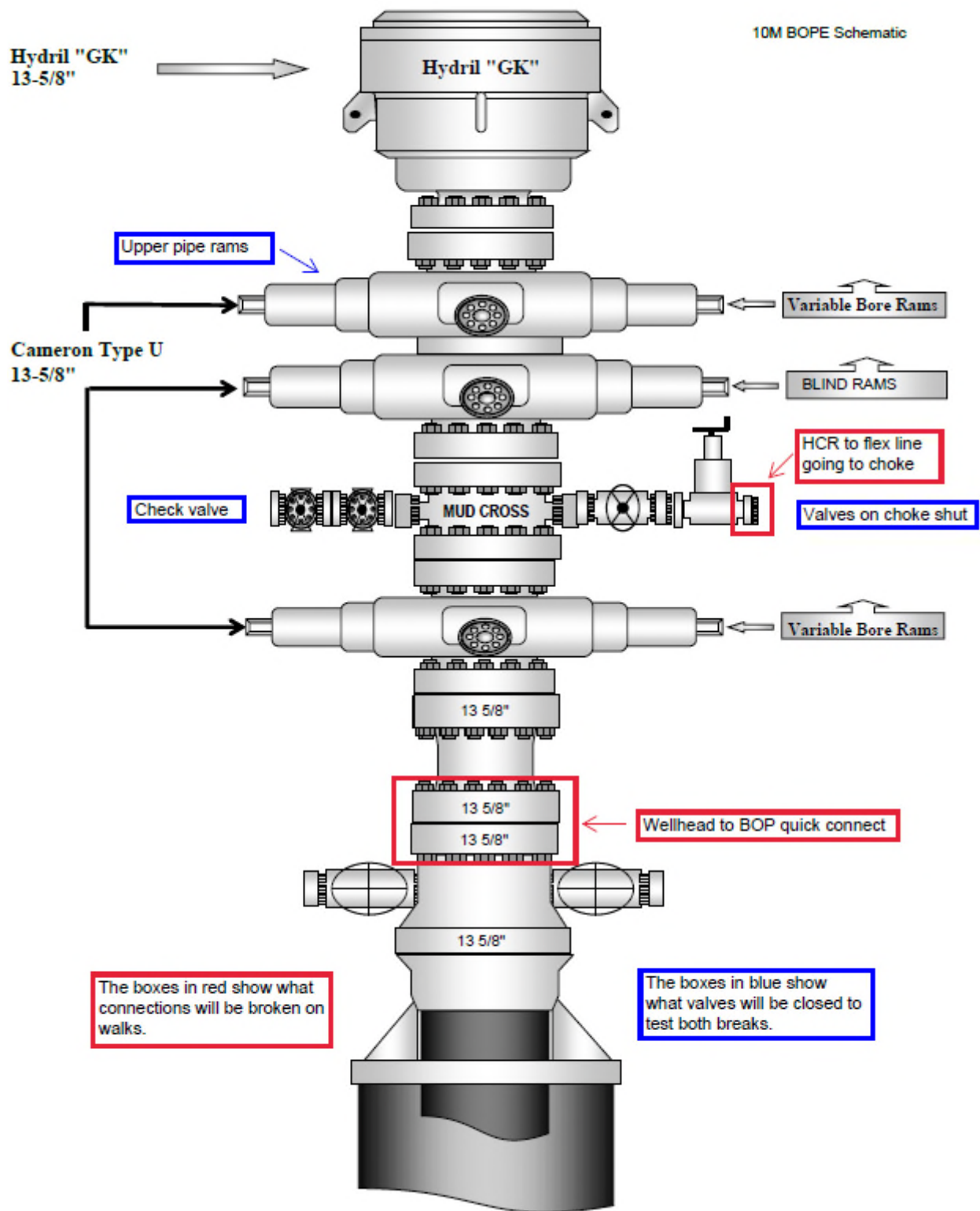
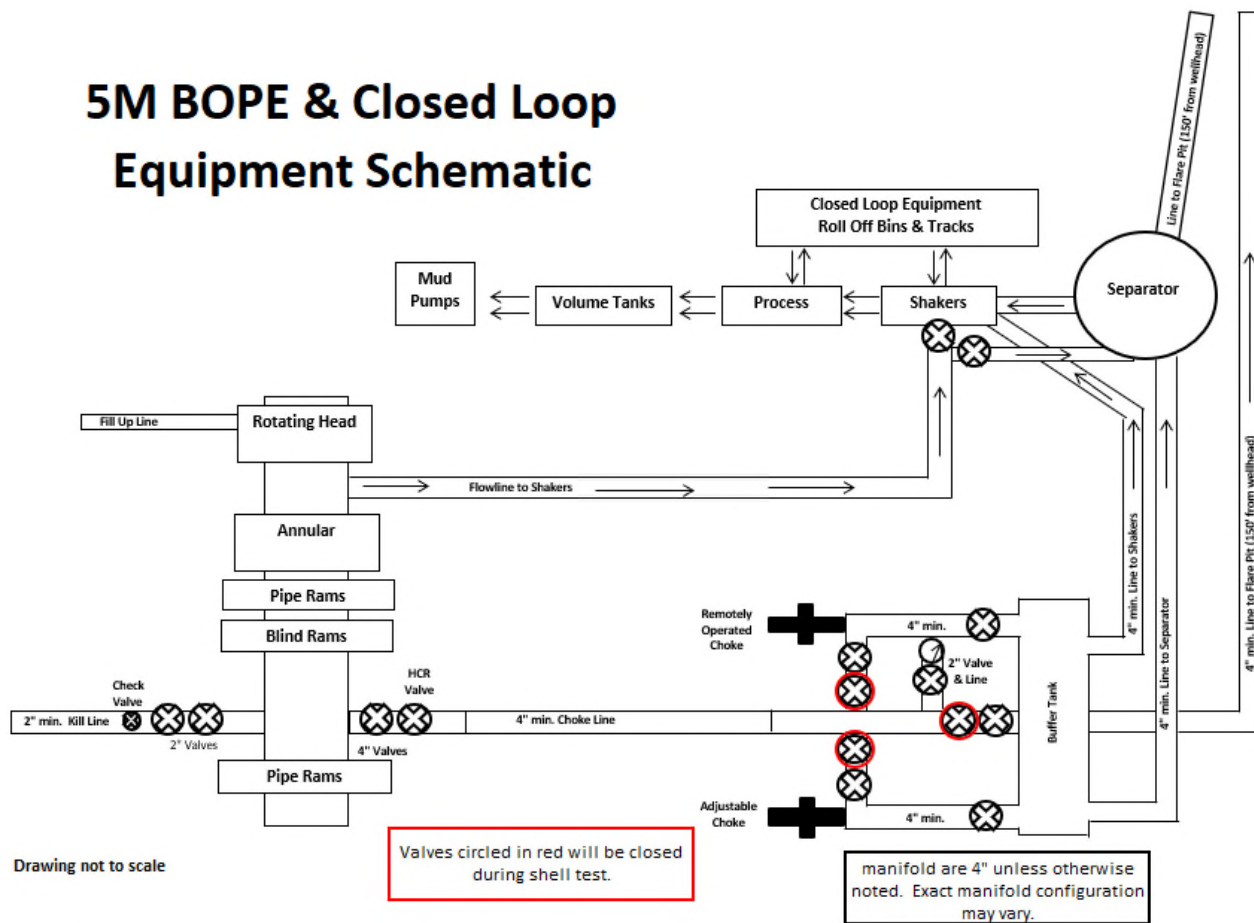

Figure 1. BOP diagram



5M BOPE & Closed Loop Equipment Schematic



Drawing not to scale

Figure 2. BOPE diagram



Figure 3. BOP handling system



Figure 4. BOP handling system

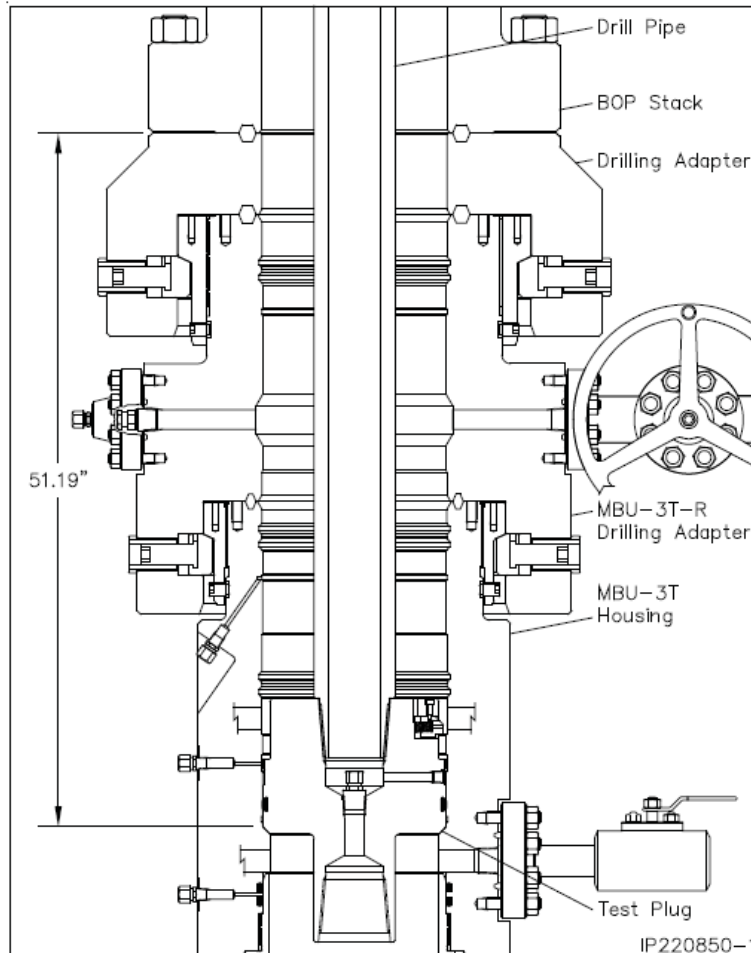

Figure 5. Cactus 5M wellhead with BOP quick connect

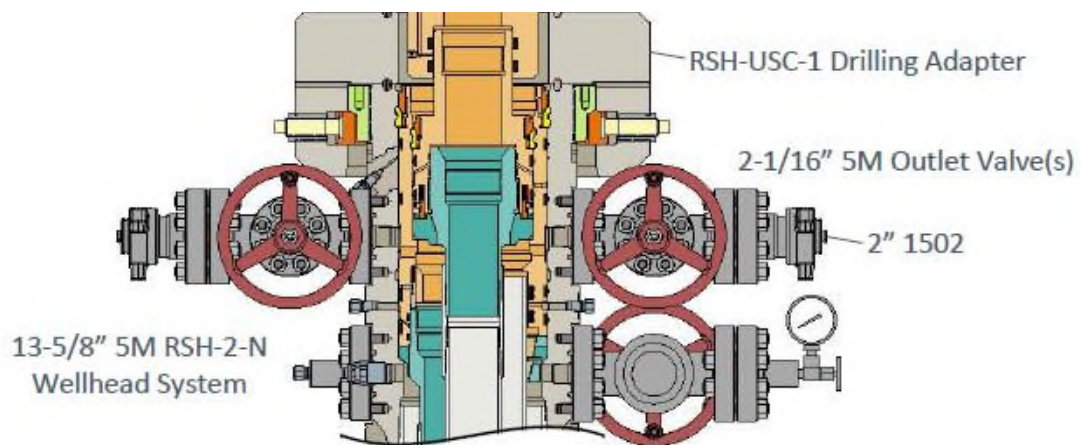
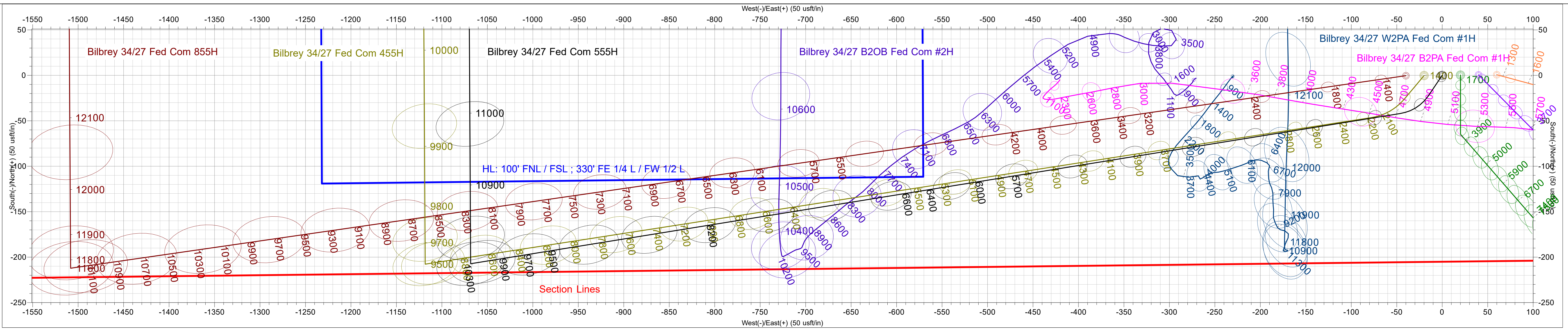

Figure 6. Vault 5M wellhead with BOP quick connect



ANNOTATIONS

MD	Inc	Azi	TVD	+N/-S	+E/-W	V Sect	Departure	Annotation
1900.00	0.00	0.00	1900.00	0.00	0.00	0.00	0.00	Begin 2.00°/100' Build
2287.00	7.74	214.00	2285.82	-21.64	-14.59	-19.91	26.10	Hold 7.74° Inc, Begin 2.00°/100' Turn
2593.76	7.74	260.82	2590.08	-42.08	-46.57	-36.74	65.42	Hold 260.82° Azi
10083.08	7.74	260.82	10011.14	-203.03	-1042.52	-87.92	1074.29	Begin 2.00°/100' Drop
10470.17	0.00	0.00	10397.05	-207.20	-1068.30	-89.25	1100.40	Begin Vertical Hold
10670.17	0.00	0.00	10597.05	-207.20	-1068.30	-89.25	1100.40	KOP, Begin 10.00°/100' Build
11572.49	90.23	359.68	11170.00	368.07	-1071.53	482.93	1675.68	Begin 90.23° Lateral
21459.16	90.23	359.68	11130.00	10254.50	-1127.10	10316.26	11562.27	PBHL

Azimuths to Grid North
 True North: -0.36°
 Magnetic North: 5.81°

Magnetic Field
 Strength: 47225.6nT
 Dip Angle: 59.95°
 Date: 1/31/2025
 Model: IGRF2020

US State Plane 1983
 New Mexico Eastern Zone

Created By: JAB
 Date: 11:51, December 04 2024
 Plan: Design #1

Grid North is 0.36° East of True North (Grid Convergence)
 To convert a Magnetic Direction to a Grid Direction, Add 5.81°
 To convert a Magnetic Direction to a True Direction, Add 6.17° East

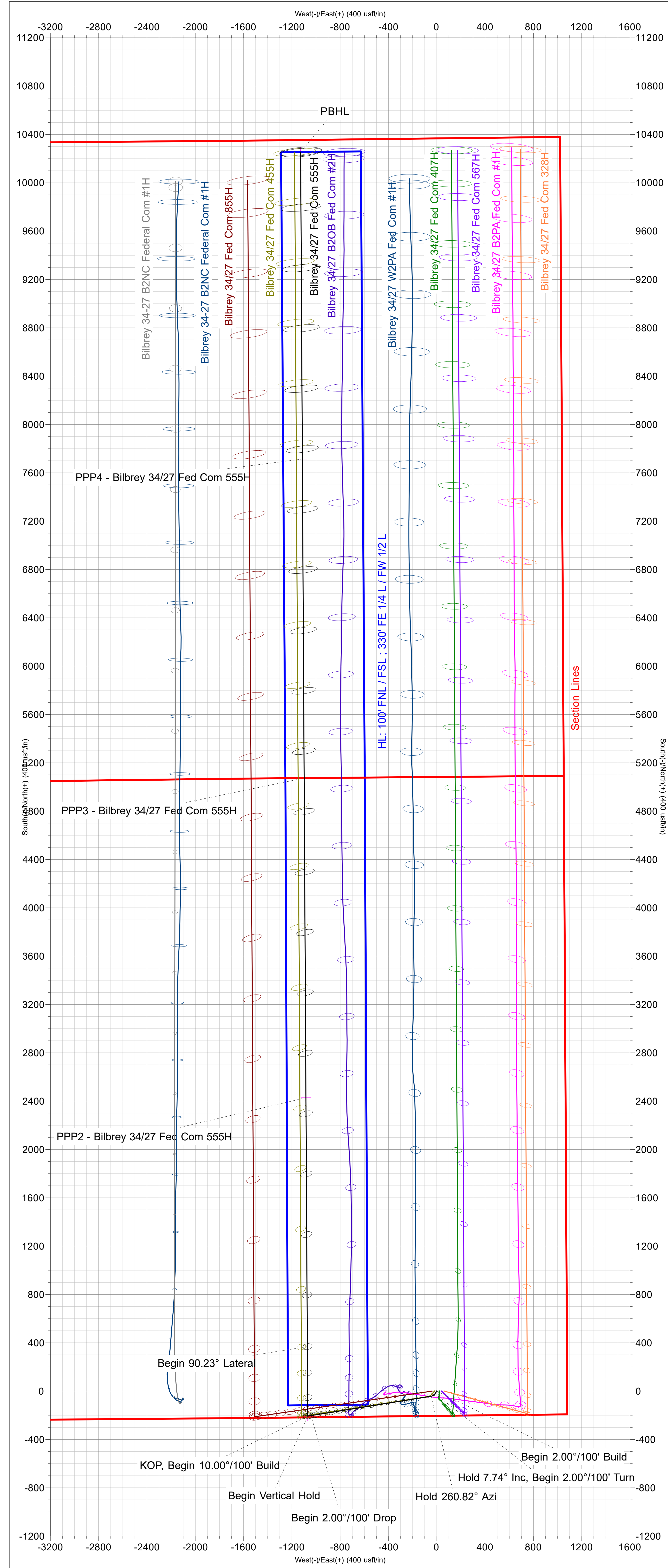
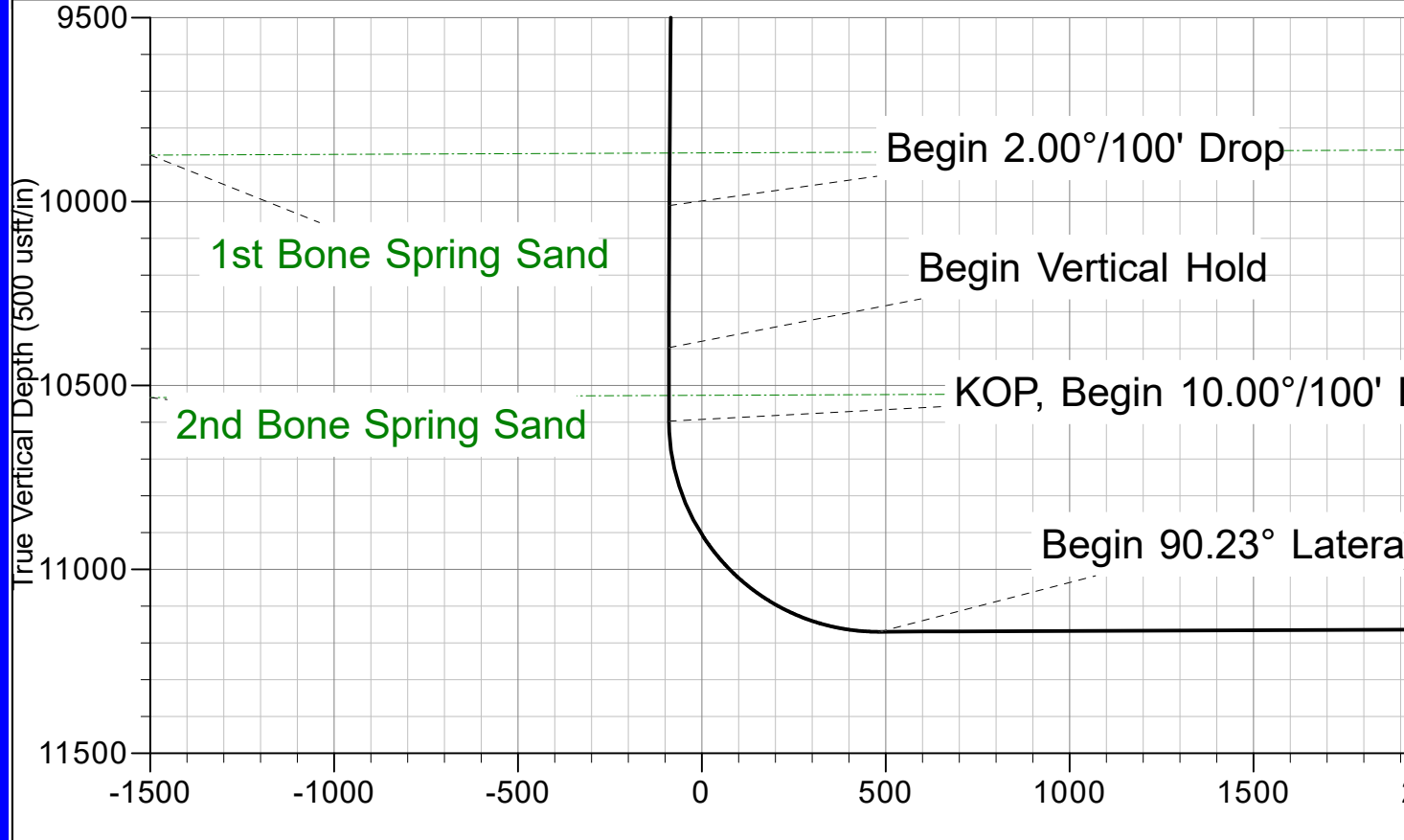
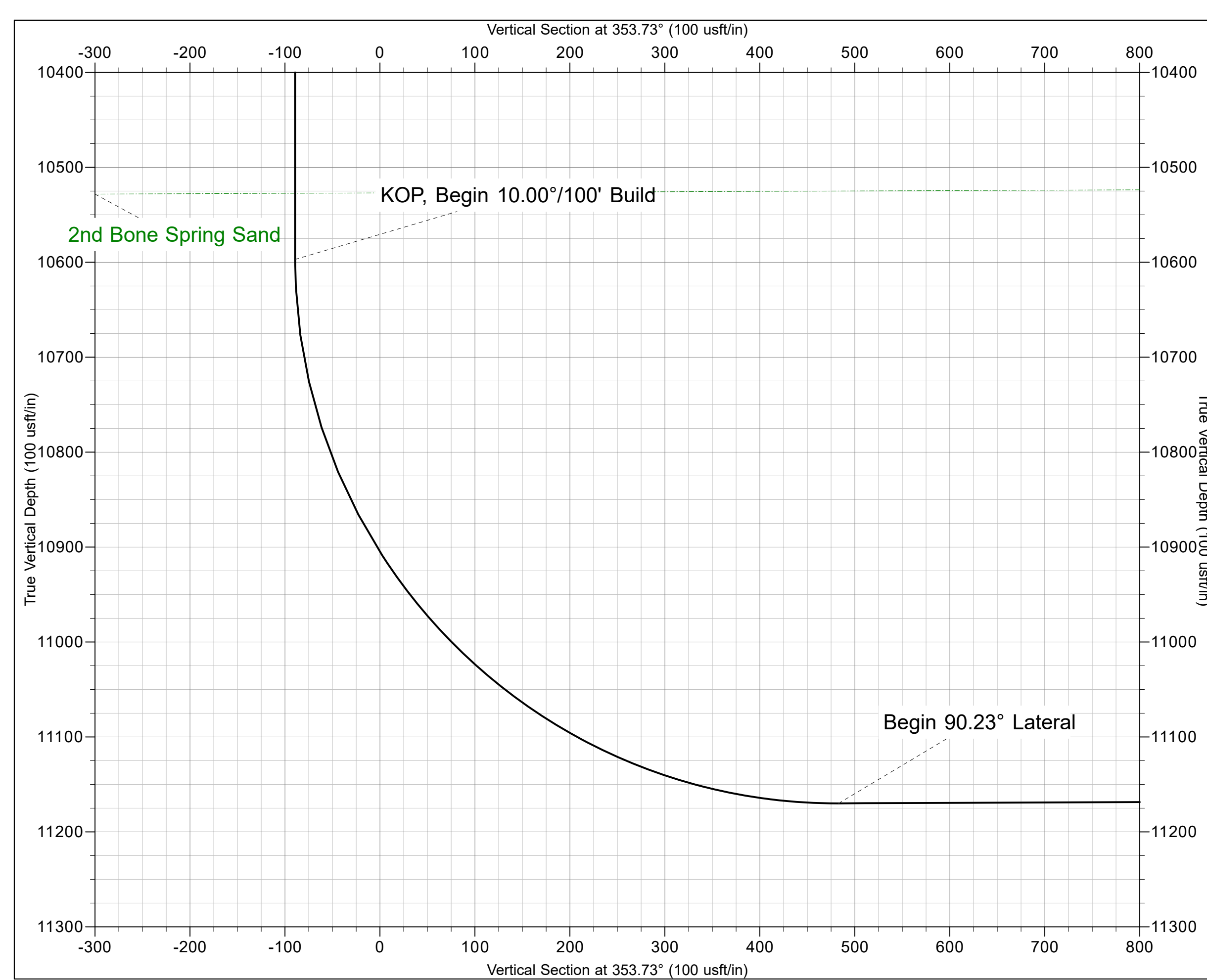
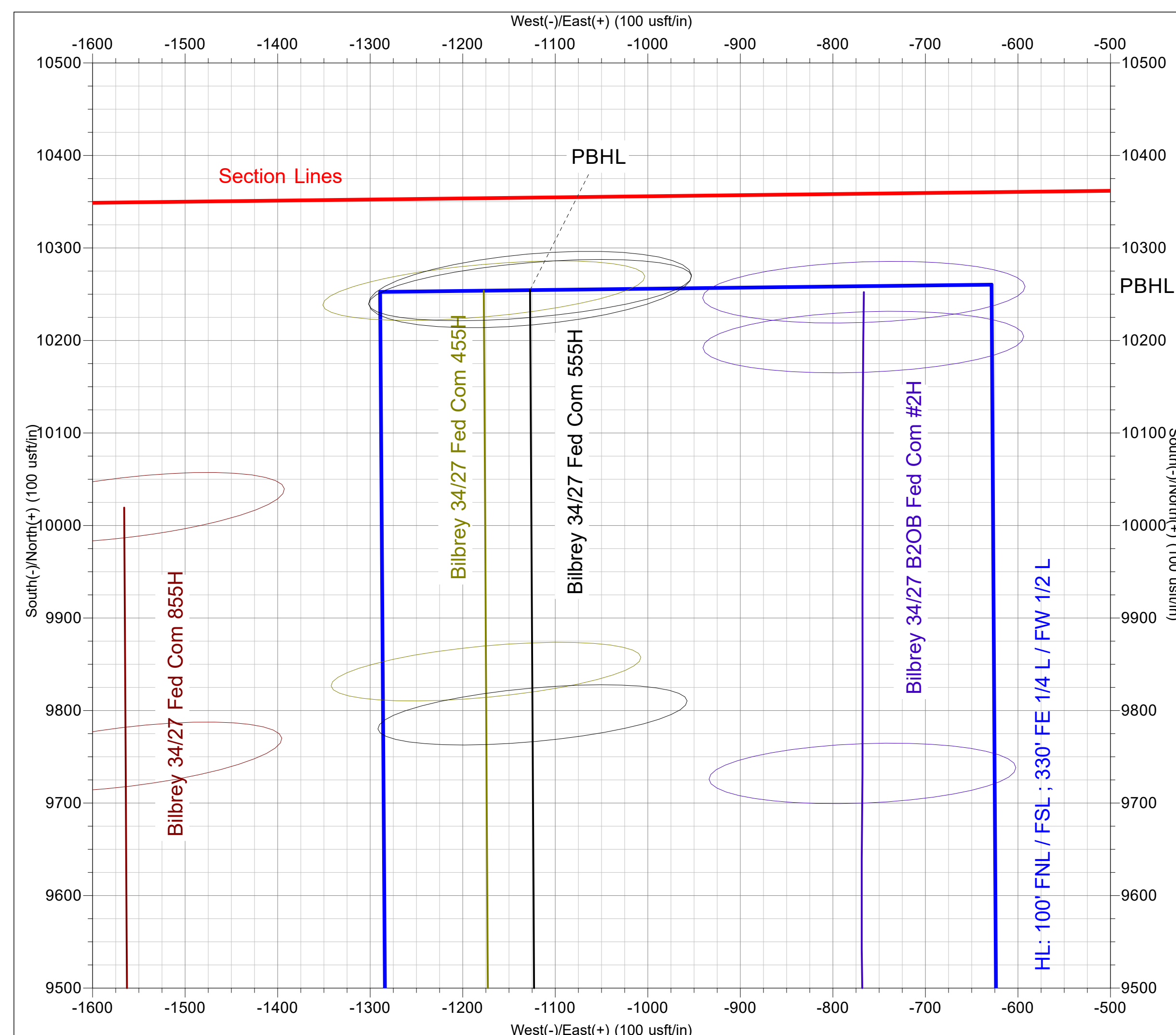
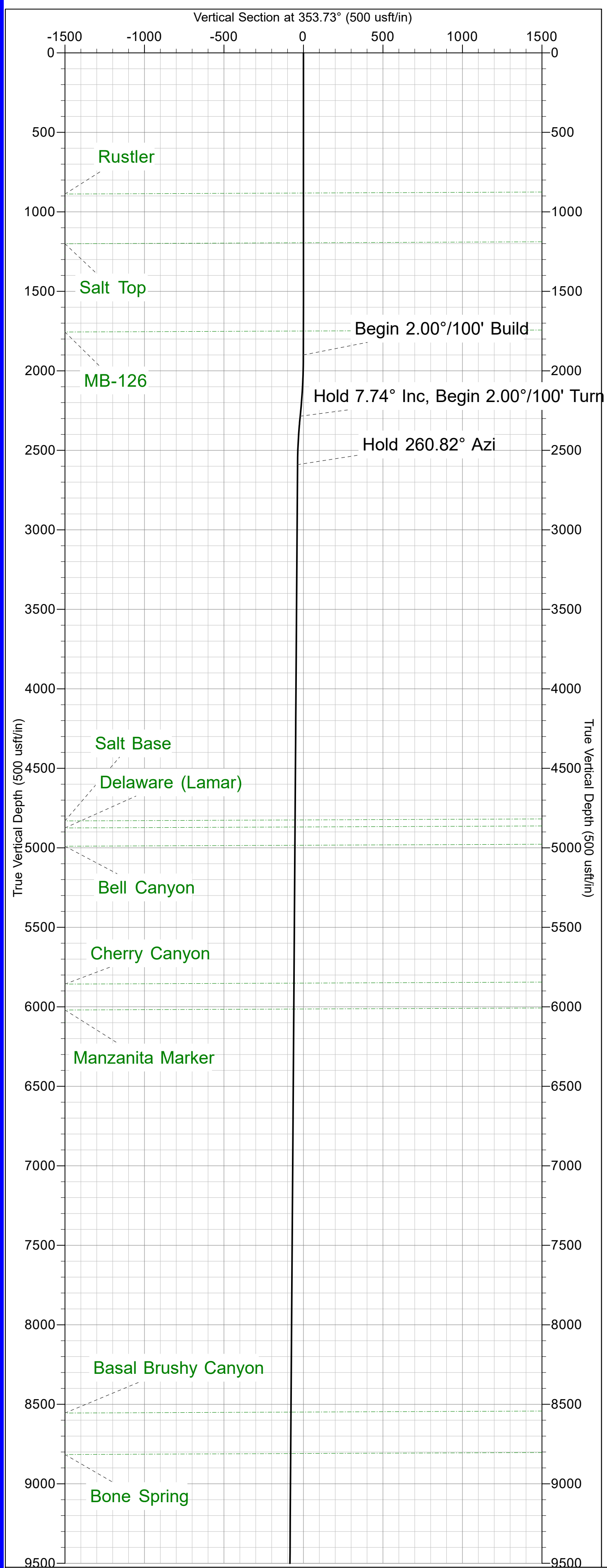



Mewbourne Oil Company

Lea County, NM (NAD83) NMEZ Grid

Bilbrey 34/27

Bilbrey 34/27 Fed Com 555H

Wellbore #1

Plan: Design #1

Standard Planning Report

03 December, 2024





Stryker Directional Planning Report



Database:	EDM 5000 Server	Local Co-ordinate Reference:	Well Bilbrey 34/27 Fed Com 555H
Company:	Mewbourne Oil Company	TVD Reference:	RKB @ 3740.00usft (Patterson 560)
Project:	Lea County, NM (NAD83) NMEZ Grid	MD Reference:	RKB @ 3740.00usft (Patterson 560)
Site:	Bilbrey 34/27	North Reference:	Grid
Well:	Bilbrey 34/27 Fed Com 555H	Survey Calculation Method:	Minimum Curvature
Wellbore:	Wellbore #1		
Design:	Design #1		

Project	Lea County, NM (NAD83) NMEZ Grid		
Map System:	US State Plane 1983	System Datum:	Mean Sea Level
Geo Datum:	North American Datum 1983		
Map Zone:	New Mexico Eastern Zone		

Site	Bilbrey 34/27				
Site Position:		Northing:	520,302.90 usft	Latitude:	32.428567
From:	Map	Easting:	749,800.40 usft	Longitude:	-103.657692
Position Uncertainty:	0.00 usft	Slot Radius:	13-3/16 "	Grid Convergence:	0.36 °

Well	Bilbrey 34/27 Fed Com 555H					
Well Position	+N/-S	0.40 usft	Northing:	520,303.30 usft	Latitude:	32.428567
	+E/-W	39.90 usft	Easting:	749,840.30 usft	Longitude:	-103.657563
Position Uncertainty		0.00 usft	Wellhead Elevation:		Ground Level:	3,712.00 usft

Wellbore	Wellbore #1				
Magnetics	Model Name	Sample Date	Declination (°)	Dip Angle (°)	Field Strength (nT)
	IGRF2020	1/31/2025	6.17	59.95	47,225.59278527

Design	Design #1			
Audit Notes:				
Version:	Phase:	PLAN	Tie On Depth:	0.00
Vertical Section:	Depth From (TVD) (usft)	+N/-S (usft)	+E/-W (usft)	Direction (°)
	0.00	0.00	0.00	353.73

Plan Sections										
Measured Depth (usft)	Inclination (°)	Azimuth (°)	Vertical Depth (usft)	+N/-S (usft)	+E/-W (usft)	Dogleg Rate (°/100usft)	Build Rate (°/100usft)	Turn Rate (°/100usft)	TFO (°)	Target
0.00	0.00	0.00	0.00	0.00	0.00	0.00	0.00	0.00	0.00	
1,900.00	0.00	0.00	1,900.00	0.00	0.00	0.00	0.00	0.00	0.00	
2,287.00	7.74	214.00	2,285.82	-21.64	-14.59	2.00	2.00	0.00	214.00	
2,593.76	7.74	260.82	2,590.08	-42.08	-46.57	2.00	0.00	15.26	113.20	
10,083.08	7.74	260.82	10,011.14	-203.03	-1,042.52	0.00	0.00	0.00	0.00	
10,470.17	0.00	0.01	10,397.05	-207.20	-1,068.30	2.00	-2.00	0.00	180.00	VP/ KOP - Bilbrey 3
10,670.17	0.00	0.01	10,597.05	-207.20	-1,068.30	0.00	0.00	0.00	0.01	
11,572.49	90.23	359.68	11,170.00	368.07	-1,071.53	10.00	10.00	-0.04	359.68	
21,459.16	90.23	359.68	11,130.00	10,254.50	-1,127.10	0.00	0.00	0.00	0.00	PBHL - Bilbrey 34/2



Stryker Directional Planning Report



Database:	EDM 5000 Server	Local Co-ordinate Reference:	Well Bilbrey 34/27 Fed Com 555H
Company:	Mewbourne Oil Company	TVD Reference:	RKB @ 3740.00usft (Patterson 560)
Project:	Lea County, NM (NAD83) NMEZ Grid	MD Reference:	RKB @ 3740.00usft (Patterson 560)
Site:	Bilbrey 34/27	North Reference:	Grid
Well:	Bilbrey 34/27 Fed Com 555H	Survey Calculation Method:	Minimum Curvature
Wellbore:	Wellbore #1		
Design:	Design #1		

Planned Survey										
Measured Depth (usft)	Inclination (°)	Azimuth (°)	Vertical Depth (usft)	+N/-S (usft)	+E/-W (usft)	Vertical Section (usft)	Dogleg Rate (°/100usft)	Build Rate (°/100usft)	Turn Rate (°/100usft)	
0.00	0.00	0.00	0.00	0.00	0.00	0.00	0.00	0.00	0.00	0.00
100.00	0.00	0.00	100.00	0.00	0.00	0.00	0.00	0.00	0.00	0.00
200.00	0.00	0.00	200.00	0.00	0.00	0.00	0.00	0.00	0.00	0.00
300.00	0.00	0.00	300.00	0.00	0.00	0.00	0.00	0.00	0.00	0.00
400.00	0.00	0.00	400.00	0.00	0.00	0.00	0.00	0.00	0.00	0.00
500.00	0.00	0.00	500.00	0.00	0.00	0.00	0.00	0.00	0.00	0.00
600.00	0.00	0.00	600.00	0.00	0.00	0.00	0.00	0.00	0.00	0.00
700.00	0.00	0.00	700.00	0.00	0.00	0.00	0.00	0.00	0.00	0.00
800.00	0.00	0.00	800.00	0.00	0.00	0.00	0.00	0.00	0.00	0.00
900.00	0.00	0.00	900.00	0.00	0.00	0.00	0.00	0.00	0.00	0.00
1,000.00	0.00	0.00	1,000.00	0.00	0.00	0.00	0.00	0.00	0.00	0.00
1,100.00	0.00	0.00	1,100.00	0.00	0.00	0.00	0.00	0.00	0.00	0.00
1,200.00	0.00	0.00	1,200.00	0.00	0.00	0.00	0.00	0.00	0.00	0.00
1,300.00	0.00	0.00	1,300.00	0.00	0.00	0.00	0.00	0.00	0.00	0.00
1,400.00	0.00	0.00	1,400.00	0.00	0.00	0.00	0.00	0.00	0.00	0.00
1,500.00	0.00	0.00	1,500.00	0.00	0.00	0.00	0.00	0.00	0.00	0.00
1,600.00	0.00	0.00	1,600.00	0.00	0.00	0.00	0.00	0.00	0.00	0.00
1,700.00	0.00	0.00	1,700.00	0.00	0.00	0.00	0.00	0.00	0.00	0.00
1,800.00	0.00	0.00	1,800.00	0.00	0.00	0.00	0.00	0.00	0.00	0.00
1,900.00	0.00	0.00	1,900.00	0.00	0.00	0.00	0.00	0.00	0.00	0.00
Begin 2.00°/100' Build										
2,000.00	2.00	214.00	1,999.98	-1.45	-0.98	-1.33	2.00	2.00	0.00	0.00
2,100.00	4.00	214.00	2,099.84	-5.79	-3.90	-5.32	2.00	2.00	0.00	0.00
2,200.00	6.00	214.00	2,199.45	-13.01	-8.78	-11.97	2.00	2.00	0.00	0.00
2,287.00	7.74	214.00	2,285.82	-21.64	-14.59	-19.91	2.00	2.00	0.00	0.00
Hold 7.74° Inc, Begin 2.00°/100' Turn										
2,300.00	7.64	215.80	2,298.71	-23.06	-15.59	-21.22	2.00	-0.76	13.83	13.83
2,400.00	7.16	230.92	2,397.88	-32.38	-24.31	-29.53	2.00	-0.49	15.12	15.12
2,500.00	7.21	246.96	2,497.11	-38.77	-34.92	-34.72	2.00	0.05	16.04	16.04
2,593.76	7.74	260.82	2,590.08	-42.08	-46.57	-36.74	2.00	0.57	14.79	14.79
Hold 260.82° Azi										
2,600.00	7.74	260.82	2,596.26	-42.21	-47.40	-36.78	0.00	0.00	0.00	0.00
2,700.00	7.74	260.82	2,695.35	-44.36	-60.70	-37.47	0.00	0.00	0.00	0.00
2,800.00	7.74	260.82	2,794.44	-46.51	-74.00	-38.15	0.00	0.00	0.00	0.00
2,900.00	7.74	260.82	2,893.53	-48.66	-87.30	-38.83	0.00	0.00	0.00	0.00
3,000.00	7.74	260.82	2,992.62	-50.81	-100.60	-39.52	0.00	0.00	0.00	0.00
3,100.00	7.74	260.82	3,091.71	-52.96	-113.89	-40.20	0.00	0.00	0.00	0.00
3,200.00	7.74	260.82	3,190.79	-55.11	-127.19	-40.88	0.00	0.00	0.00	0.00
3,300.00	7.74	260.82	3,289.88	-57.26	-140.49	-41.57	0.00	0.00	0.00	0.00
3,400.00	7.74	260.82	3,388.97	-59.41	-153.79	-42.25	0.00	0.00	0.00	0.00
3,500.00	7.74	260.82	3,488.06	-61.56	-167.09	-42.93	0.00	0.00	0.00	0.00
3,600.00	7.74	260.82	3,587.15	-63.70	-180.39	-43.62	0.00	0.00	0.00	0.00
3,700.00	7.74	260.82	3,686.24	-65.85	-193.68	-44.30	0.00	0.00	0.00	0.00
3,800.00	7.74	260.82	3,785.33	-68.00	-206.98	-44.98	0.00	0.00	0.00	0.00
3,900.00	7.74	260.82	3,884.41	-70.15	-220.28	-45.67	0.00	0.00	0.00	0.00
4,000.00	7.74	260.82	3,983.50	-72.30	-233.58	-46.35	0.00	0.00	0.00	0.00
4,100.00	7.74	260.82	4,082.59	-74.45	-246.88	-47.03	0.00	0.00	0.00	0.00
4,200.00	7.74	260.82	4,181.68	-76.60	-260.18	-47.72	0.00	0.00	0.00	0.00
4,300.00	7.74	260.82	4,280.77	-78.75	-273.47	-48.40	0.00	0.00	0.00	0.00
4,400.00	7.74	260.82	4,379.86	-80.90	-286.77	-49.08	0.00	0.00	0.00	0.00
4,500.00	7.74	260.82	4,478.94	-83.05	-300.07	-49.77	0.00	0.00	0.00	0.00
4,600.00	7.74	260.82	4,578.03	-85.20	-313.37	-50.45	0.00	0.00	0.00	0.00
4,700.00	7.74	260.82	4,677.12	-87.34	-326.67	-51.13	0.00	0.00	0.00	0.00



Stryker Directional Planning Report



Database:	EDM 5000 Server	Local Co-ordinate Reference:	Well Bilbrey 34/27 Fed Com 555H
Company:	Mewbourne Oil Company	TVD Reference:	RKB @ 3740.00usft (Patterson 560)
Project:	Lea County, NM (NAD83) NMEZ Grid	MD Reference:	RKB @ 3740.00usft (Patterson 560)
Site:	Bilbrey 34/27	North Reference:	Grid
Well:	Bilbrey 34/27 Fed Com 555H	Survey Calculation Method:	Minimum Curvature
Wellbore:	Wellbore #1		
Design:	Design #1		

Planned Survey										
Measured Depth (usft)	Inclination (°)	Azimuth (°)	Vertical Depth (usft)	+N/-S (usft)	+E/-W (usft)	Vertical Section (usft)	Dogleg Rate (°/100usft)	Build Rate (°/100usft)	Turn Rate (°/100usft)	
4,800.00	7.74	260.82	4,776.21	-89.49	-339.96	-51.82	0.00	0.00	0.00	
4,900.00	7.74	260.82	4,875.30	-91.64	-353.26	-52.50	0.00	0.00	0.00	
5,000.00	7.74	260.82	4,974.39	-93.79	-366.56	-53.18	0.00	0.00	0.00	
5,100.00	7.74	260.82	5,073.48	-95.94	-379.86	-53.87	0.00	0.00	0.00	
5,200.00	7.74	260.82	5,172.56	-98.09	-393.16	-54.55	0.00	0.00	0.00	
5,300.00	7.74	260.82	5,271.65	-100.24	-406.46	-55.23	0.00	0.00	0.00	
5,400.00	7.74	260.82	5,370.74	-102.39	-419.75	-55.92	0.00	0.00	0.00	
5,500.00	7.74	260.82	5,469.83	-104.54	-433.05	-56.60	0.00	0.00	0.00	
5,600.00	7.74	260.82	5,568.92	-106.69	-446.35	-57.29	0.00	0.00	0.00	
5,700.00	7.74	260.82	5,668.01	-108.84	-459.65	-57.97	0.00	0.00	0.00	
5,800.00	7.74	260.82	5,767.10	-110.99	-472.95	-58.65	0.00	0.00	0.00	
5,900.00	7.74	260.82	5,866.18	-113.13	-486.25	-59.34	0.00	0.00	0.00	
6,000.00	7.74	260.82	5,965.27	-115.28	-499.54	-60.02	0.00	0.00	0.00	
6,100.00	7.74	260.82	6,064.36	-117.43	-512.84	-60.70	0.00	0.00	0.00	
6,200.00	7.74	260.82	6,163.45	-119.58	-526.14	-61.39	0.00	0.00	0.00	
6,300.00	7.74	260.82	6,262.54	-121.73	-539.44	-62.07	0.00	0.00	0.00	
6,400.00	7.74	260.82	6,361.63	-123.88	-552.74	-62.75	0.00	0.00	0.00	
6,500.00	7.74	260.82	6,460.72	-126.03	-566.04	-63.44	0.00	0.00	0.00	
6,600.00	7.74	260.82	6,559.80	-128.18	-579.33	-64.12	0.00	0.00	0.00	
6,700.00	7.74	260.82	6,658.89	-130.33	-592.63	-64.80	0.00	0.00	0.00	
6,800.00	7.74	260.82	6,757.98	-132.48	-605.93	-65.49	0.00	0.00	0.00	
6,900.00	7.74	260.82	6,857.07	-134.63	-619.23	-66.17	0.00	0.00	0.00	
7,000.00	7.74	260.82	6,956.16	-136.77	-632.53	-66.85	0.00	0.00	0.00	
7,100.00	7.74	260.82	7,055.25	-138.92	-645.82	-67.54	0.00	0.00	0.00	
7,200.00	7.74	260.82	7,154.34	-141.07	-659.12	-68.22	0.00	0.00	0.00	
7,300.00	7.74	260.82	7,253.42	-143.22	-672.42	-68.90	0.00	0.00	0.00	
7,400.00	7.74	260.82	7,352.51	-145.37	-685.72	-69.59	0.00	0.00	0.00	
7,500.00	7.74	260.82	7,451.60	-147.52	-699.02	-70.27	0.00	0.00	0.00	
7,600.00	7.74	260.82	7,550.69	-149.67	-712.32	-70.95	0.00	0.00	0.00	
7,700.00	7.74	260.82	7,649.78	-151.82	-725.61	-71.64	0.00	0.00	0.00	
7,800.00	7.74	260.82	7,748.87	-153.97	-738.91	-72.32	0.00	0.00	0.00	
7,900.00	7.74	260.82	7,847.96	-156.12	-752.21	-73.00	0.00	0.00	0.00	
8,000.00	7.74	260.82	7,947.04	-158.27	-765.51	-73.69	0.00	0.00	0.00	
8,100.00	7.74	260.82	8,046.13	-160.42	-778.81	-74.37	0.00	0.00	0.00	
8,200.00	7.74	260.82	8,145.22	-162.56	-792.11	-75.05	0.00	0.00	0.00	
8,300.00	7.74	260.82	8,244.31	-164.71	-805.40	-75.74	0.00	0.00	0.00	
8,400.00	7.74	260.82	8,343.40	-166.86	-818.70	-76.42	0.00	0.00	0.00	
8,500.00	7.74	260.82	8,442.49	-169.01	-832.00	-77.11	0.00	0.00	0.00	
8,600.00	7.74	260.82	8,541.57	-171.16	-845.30	-77.79	0.00	0.00	0.00	
8,700.00	7.74	260.82	8,640.66	-173.31	-858.60	-78.47	0.00	0.00	0.00	
8,800.00	7.74	260.82	8,739.75	-175.46	-871.90	-79.16	0.00	0.00	0.00	
8,900.00	7.74	260.82	8,838.84	-177.61	-885.19	-79.84	0.00	0.00	0.00	
9,000.00	7.74	260.82	8,937.93	-179.76	-898.49	-80.52	0.00	0.00	0.00	
9,100.00	7.74	260.82	9,037.02	-181.91	-911.79	-81.21	0.00	0.00	0.00	
9,200.00	7.74	260.82	9,136.11	-184.06	-925.09	-81.89	0.00	0.00	0.00	
9,300.00	7.74	260.82	9,235.19	-186.20	-938.39	-82.57	0.00	0.00	0.00	
9,400.00	7.74	260.82	9,334.28	-188.35	-951.68	-83.26	0.00	0.00	0.00	
9,500.00	7.74	260.82	9,433.37	-190.50	-964.98	-83.94	0.00	0.00	0.00	
9,600.00	7.74	260.82	9,532.46	-192.65	-978.28	-84.62	0.00	0.00	0.00	
9,700.00	7.74	260.82	9,631.55	-194.80	-991.58	-85.31	0.00	0.00	0.00	
9,800.00	7.74	260.82	9,730.64	-196.95	-1,004.88	-85.99	0.00	0.00	0.00	
9,900.00	7.74	260.82	9,829.73	-199.10	-1,018.18	-86.67	0.00	0.00	0.00	
10,000.00	7.74	260.82	9,928.81	-201.25	-1,031.47	-87.36	0.00	0.00	0.00	
10,083.08	7.74	260.82	10,011.14	-203.03	-1,042.52	-87.92	0.00	0.00	0.00	

Stryker Directional
Planning Report



Database:	EDM 5000 Server	Local Co-ordinate Reference:	Well Bilbrey 34/27 Fed Com 555H
Company:	Mewbourne Oil Company	TVD Reference:	RKB @ 3740.00usft (Patterson 560)
Project:	Lea County, NM (NAD83) NMEZ Grid	MD Reference:	RKB @ 3740.00usft (Patterson 560)
Site:	Bilbrey 34/27	North Reference:	Grid
Well:	Bilbrey 34/27 Fed Com 555H	Survey Calculation Method:	Minimum Curvature
Wellbore:	Wellbore #1		
Design:	Design #1		

Planned Survey										
Measured Depth (usft)	Inclination (°)	Azimuth (°)	Vertical Depth (usft)	+N/-S (usft)	+E/-W (usft)	Vertical Section (usft)	Dogleg Rate (°/100usft)	Build Rate (°/100usft)	Turn Rate (°/100usft)	
Begin 2.00°/100' Drop										
10,100.00	7.40	260.82	10,027.91	-203.39	-1,044.72	-88.04	2.00	-2.00	0.00	
10,200.00	5.40	260.82	10,127.28	-205.17	-1,055.73	-88.60	2.00	-2.00	0.00	
10,300.00	3.40	260.82	10,226.98	-206.39	-1,063.31	-88.99	2.00	-2.00	0.00	
10,400.00	1.40	260.82	10,326.89	-207.06	-1,067.45	-89.21	2.00	-2.00	0.00	
10,470.17	0.00	0.01	10,397.05	-207.20	-1,068.30	-89.25	2.00	-2.00	0.00	
Begin Vertical Hold										
10,500.00	0.00	0.00	10,426.88	-207.20	-1,068.30	-89.25	0.00	0.00	0.00	
10,600.00	0.00	0.00	10,526.88	-207.20	-1,068.30	-89.25	0.00	0.00	0.00	
10,670.17	0.00	0.00	10,597.05	-207.20	-1,068.30	-89.25	0.00	0.00	0.00	
KOP, Begin 10.00°/100' Build										
10,700.00	2.98	359.68	10,626.87	-206.42	-1,068.30	-88.48	10.00	10.00	0.00	
10,750.00	7.98	359.68	10,676.62	-201.65	-1,068.33	-83.73	10.00	10.00	0.00	
10,800.00	12.98	359.68	10,725.77	-192.55	-1,068.38	-74.68	10.00	10.00	0.00	
10,850.00	17.98	359.68	10,773.94	-179.21	-1,068.46	-61.41	10.00	10.00	0.00	
10,900.00	22.98	359.68	10,820.77	-161.72	-1,068.56	-44.01	10.00	10.00	0.00	
10,950.00	27.98	359.68	10,865.89	-140.21	-1,068.68	-22.62	10.00	10.00	0.00	
11,000.00	32.98	359.68	10,908.96	-114.86	-1,068.82	2.60	10.00	10.00	0.00	
11,050.00	37.98	359.68	10,949.66	-85.85	-1,068.98	31.45	10.00	10.00	0.00	
11,100.00	42.98	359.68	10,987.68	-53.40	-1,069.16	63.73	10.00	10.00	0.00	
11,150.00	47.98	359.68	11,022.73	-17.76	-1,069.36	99.18	10.00	10.00	0.00	
11,200.00	52.98	359.68	11,054.53	20.80	-1,069.58	137.53	10.00	10.00	0.00	
11,250.00	57.98	359.68	11,082.86	61.99	-1,069.81	178.49	10.00	10.00	0.00	
11,300.00	62.98	359.68	11,107.48	105.48	-1,070.06	221.75	10.00	10.00	0.00	
11,350.00	67.98	359.68	11,128.22	150.96	-1,070.31	266.99	10.00	10.00	0.00	
11,400.00	72.98	359.68	11,144.92	198.07	-1,070.58	313.85	10.00	10.00	0.00	
11,450.00	77.98	359.68	11,157.45	246.46	-1,070.85	361.97	10.00	10.00	0.00	
11,500.00	82.98	359.68	11,165.72	295.76	-1,071.13	411.00	10.00	10.00	0.00	
11,550.00	87.98	359.68	11,169.65	345.58	-1,071.41	460.56	10.00	10.00	0.00	
11,572.49	90.23	359.68	11,170.00	368.07	-1,071.53	482.93	10.00	10.00	0.00	
Begin 90.23° Lateral										
11,600.00	90.23	359.68	11,169.89	395.58	-1,071.69	510.29	0.00	0.00	0.00	
11,700.00	90.23	359.68	11,169.49	495.58	-1,072.25	609.75	0.00	0.00	0.00	
11,800.00	90.23	359.68	11,169.08	595.57	-1,072.81	709.21	0.00	0.00	0.00	
11,900.00	90.23	359.68	11,168.68	695.57	-1,073.37	808.67	0.00	0.00	0.00	
12,000.00	90.23	359.68	11,168.27	795.57	-1,073.94	908.13	0.00	0.00	0.00	
12,100.00	90.23	359.68	11,167.87	895.57	-1,074.50	1,007.59	0.00	0.00	0.00	
12,200.00	90.23	359.68	11,167.46	995.56	-1,075.06	1,107.05	0.00	0.00	0.00	
12,300.00	90.23	359.68	11,167.06	1,095.56	-1,075.62	1,206.51	0.00	0.00	0.00	
12,400.00	90.23	359.68	11,166.66	1,195.56	-1,076.18	1,305.97	0.00	0.00	0.00	
12,500.00	90.23	359.68	11,166.25	1,295.56	-1,076.75	1,405.43	0.00	0.00	0.00	
12,600.00	90.23	359.68	11,165.85	1,395.55	-1,077.31	1,504.90	0.00	0.00	0.00	
12,700.00	90.23	359.68	11,165.44	1,495.55	-1,077.87	1,604.36	0.00	0.00	0.00	
12,800.00	90.23	359.68	11,165.04	1,595.55	-1,078.43	1,703.82	0.00	0.00	0.00	
12,900.00	90.23	359.68	11,164.63	1,695.55	-1,078.99	1,803.28	0.00	0.00	0.00	
13,000.00	90.23	359.68	11,164.23	1,795.54	-1,079.56	1,902.74	0.00	0.00	0.00	
13,100.00	90.23	359.68	11,163.82	1,895.54	-1,080.12	2,002.20	0.00	0.00	0.00	
13,200.00	90.23	359.68	11,163.42	1,995.54	-1,080.68	2,101.66	0.00	0.00	0.00	
13,300.00	90.23	359.68	11,163.01	2,095.54	-1,081.24	2,201.12	0.00	0.00	0.00	
13,400.00	90.23	359.68	11,162.61	2,195.53	-1,081.80	2,300.58	0.00	0.00	0.00	
13,500.00	90.23	359.68	11,162.20	2,295.53	-1,082.37	2,400.04	0.00	0.00	0.00	
13,600.00	90.23	359.68	11,161.80	2,395.53	-1,082.93	2,499.50	0.00	0.00	0.00	
13,700.00	90.23	359.68	11,161.40	2,495.53	-1,083.49	2,598.96	0.00	0.00	0.00	

Stryker Directional
Planning Report



Database:	EDM 5000 Server	Local Co-ordinate Reference:	Well Bilbrey 34/27 Fed Com 555H
Company:	Mewbourne Oil Company	TVD Reference:	RKB @ 3740.00usft (Patterson 560)
Project:	Lea County, NM (NAD83) NMEZ Grid	MD Reference:	RKB @ 3740.00usft (Patterson 560)
Site:	Bilbrey 34/27	North Reference:	Grid
Well:	Bilbrey 34/27 Fed Com 555H	Survey Calculation Method:	Minimum Curvature
Wellbore:	Wellbore #1		
Design:	Design #1		

Planned Survey										
Measured Depth (usft)	Inclination (°)	Azimuth (°)	Vertical Depth (usft)	+N/-S (usft)	+E/-W (usft)	Vertical Section (usft)	Dogleg Rate (°/100usft)	Build Rate (°/100usft)	Turn Rate (°/100usft)	
13,800.00	90.23	359.68	11,160.99	2,595.53	-1,084.05	2,698.42	0.00	0.00	0.00	
13,900.00	90.23	359.68	11,160.59	2,695.52	-1,084.61	2,797.88	0.00	0.00	0.00	
14,000.00	90.23	359.68	11,160.18	2,795.52	-1,085.18	2,897.34	0.00	0.00	0.00	
14,100.00	90.23	359.68	11,159.78	2,895.52	-1,085.74	2,996.80	0.00	0.00	0.00	
14,200.00	90.23	359.68	11,159.37	2,995.52	-1,086.30	3,096.26	0.00	0.00	0.00	
14,300.00	90.23	359.68	11,158.97	3,095.51	-1,086.86	3,195.72	0.00	0.00	0.00	
14,400.00	90.23	359.68	11,158.56	3,195.51	-1,087.42	3,295.18	0.00	0.00	0.00	
14,500.00	90.23	359.68	11,158.16	3,295.51	-1,087.99	3,394.64	0.00	0.00	0.00	
14,600.00	90.23	359.68	11,157.75	3,395.51	-1,088.55	3,494.10	0.00	0.00	0.00	
14,700.00	90.23	359.68	11,157.35	3,495.50	-1,089.11	3,593.57	0.00	0.00	0.00	
14,800.00	90.23	359.68	11,156.94	3,595.50	-1,089.67	3,693.03	0.00	0.00	0.00	
14,900.00	90.23	359.68	11,156.54	3,695.50	-1,090.24	3,792.49	0.00	0.00	0.00	
15,000.00	90.23	359.68	11,156.14	3,795.50	-1,090.80	3,891.95	0.00	0.00	0.00	
15,100.00	90.23	359.68	11,155.73	3,895.49	-1,091.36	3,991.41	0.00	0.00	0.00	
15,200.00	90.23	359.68	11,155.33	3,995.49	-1,091.92	4,090.87	0.00	0.00	0.00	
15,300.00	90.23	359.68	11,154.92	4,095.49	-1,092.48	4,190.33	0.00	0.00	0.00	
15,400.00	90.23	359.68	11,154.52	4,195.49	-1,093.05	4,289.79	0.00	0.00	0.00	
15,500.00	90.23	359.68	11,154.11	4,295.48	-1,093.61	4,389.25	0.00	0.00	0.00	
15,600.00	90.23	359.68	11,153.71	4,395.48	-1,094.17	4,488.71	0.00	0.00	0.00	
15,700.00	90.23	359.68	11,153.30	4,495.48	-1,094.73	4,588.17	0.00	0.00	0.00	
15,800.00	90.23	359.68	11,152.90	4,595.48	-1,095.29	4,687.63	0.00	0.00	0.00	
15,900.00	90.23	359.68	11,152.49	4,695.48	-1,095.86	4,787.09	0.00	0.00	0.00	
16,000.00	90.23	359.68	11,152.09	4,795.47	-1,096.42	4,886.55	0.00	0.00	0.00	
16,100.00	90.23	359.68	11,151.68	4,895.47	-1,096.98	4,986.01	0.00	0.00	0.00	
16,200.00	90.23	359.68	11,151.28	4,995.47	-1,097.54	5,085.47	0.00	0.00	0.00	
16,300.00	90.23	359.68	11,150.88	5,095.47	-1,098.10	5,184.93	0.00	0.00	0.00	
16,400.00	90.23	359.68	11,150.47	5,195.46	-1,098.67	5,284.39	0.00	0.00	0.00	
16,500.00	90.23	359.68	11,150.07	5,295.46	-1,099.23	5,383.85	0.00	0.00	0.00	
16,600.00	90.23	359.68	11,149.66	5,395.46	-1,099.79	5,483.31	0.00	0.00	0.00	
16,700.00	90.23	359.68	11,149.26	5,495.46	-1,100.35	5,582.77	0.00	0.00	0.00	
16,800.00	90.23	359.68	11,148.85	5,595.45	-1,100.91	5,682.23	0.00	0.00	0.00	
16,900.00	90.23	359.68	11,148.45	5,695.45	-1,101.48	5,781.70	0.00	0.00	0.00	
17,000.00	90.23	359.68	11,148.04	5,795.45	-1,102.04	5,881.16	0.00	0.00	0.00	
17,100.00	90.23	359.68	11,147.64	5,895.45	-1,102.60	5,980.62	0.00	0.00	0.00	
17,200.00	90.23	359.68	11,147.23	5,995.44	-1,103.16	6,080.08	0.00	0.00	0.00	
17,300.00	90.23	359.68	11,146.83	6,095.44	-1,103.72	6,179.54	0.00	0.00	0.00	
17,400.00	90.23	359.68	11,146.42	6,195.44	-1,104.29	6,279.00	0.00	0.00	0.00	
17,500.00	90.23	359.68	11,146.02	6,295.44	-1,104.85	6,378.46	0.00	0.00	0.00	
17,600.00	90.23	359.68	11,145.62	6,395.43	-1,105.41	6,477.92	0.00	0.00	0.00	
17,700.00	90.23	359.68	11,145.21	6,495.43	-1,105.97	6,577.38	0.00	0.00	0.00	
17,800.00	90.23	359.68	11,144.81	6,595.43	-1,106.53	6,676.84	0.00	0.00	0.00	
17,900.00	90.23	359.68	11,144.40	6,695.43	-1,107.10	6,776.30	0.00	0.00	0.00	
18,000.00	90.23	359.68	11,144.00	6,795.42	-1,107.66	6,875.76	0.00	0.00	0.00	
18,100.00	90.23	359.68	11,143.59	6,895.42	-1,108.22	6,975.22	0.00	0.00	0.00	
18,200.00	90.23	359.68	11,143.19	6,995.42	-1,108.78	7,074.68	0.00	0.00	0.00	
18,300.00	90.23	359.68	11,142.78	7,095.42	-1,109.34	7,174.14	0.00	0.00	0.00	
18,400.00	90.23	359.68	11,142.38	7,195.42	-1,109.91	7,273.60	0.00	0.00	0.00	
18,500.00	90.23	359.68	11,141.97	7,295.41	-1,110.47	7,373.06	0.00	0.00	0.00	
18,600.00	90.23	359.68	11,141.57	7,395.41	-1,111.03	7,472.52	0.00	0.00	0.00	
18,700.00	90.23	359.68	11,141.16	7,495.41	-1,111.59	7,571.98	0.00	0.00	0.00	
18,800.00	90.23	359.68	11,140.76	7,595.41	-1,112.15	7,671.44	0.00	0.00	0.00	
18,900.00	90.23	359.68	11,140.36	7,695.40	-1,112.72	7,770.90	0.00	0.00	0.00	
19,000.00	90.23	359.68	11,139.95	7,795.40	-1,113.28	7,870.37	0.00	0.00	0.00	
19,100.00	90.23	359.68	11,139.55	7,895.40	-1,113.84	7,969.83	0.00	0.00	0.00	



Stryker Directional
Planning Report



Database:	EDM 5000 Server	Local Co-ordinate Reference:	Well Bilbrey 34/27 Fed Com 555H
Company:	Mewbourne Oil Company	TVD Reference:	RKB @ 3740.00usft (Patterson 560)
Project:	Lea County, NM (NAD83) NMEZ Grid	MD Reference:	RKB @ 3740.00usft (Patterson 560)
Site:	Bilbrey 34/27	North Reference:	Grid
Well:	Bilbrey 34/27 Fed Com 555H	Survey Calculation Method:	Minimum Curvature
Wellbore:	Wellbore #1		
Design:	Design #1		

Planned Survey										
Measured Depth (usft)	Inclination (°)	Azimuth (°)	Vertical Depth (usft)	+N/-S (usft)	+E/-W (usft)	Vertical Section (usft)	Dogleg Rate (°/100usft)	Build Rate (°/100usft)	Turn Rate (°/100usft)	
19,200.00	90.23	359.68	11,139.14	7,995.40	-1,114.40	8,069.29	0.00	0.00	0.00	
19,300.00	90.23	359.68	11,138.74	8,095.39	-1,114.96	8,168.75	0.00	0.00	0.00	
19,400.00	90.23	359.68	11,138.33	8,195.39	-1,115.53	8,268.21	0.00	0.00	0.00	
19,500.00	90.23	359.68	11,137.93	8,295.39	-1,116.09	8,367.67	0.00	0.00	0.00	
19,600.00	90.23	359.68	11,137.52	8,395.39	-1,116.65	8,467.13	0.00	0.00	0.00	
19,700.00	90.23	359.68	11,137.12	8,495.38	-1,117.21	8,566.59	0.00	0.00	0.00	
19,800.00	90.23	359.68	11,136.71	8,595.38	-1,117.77	8,666.05	0.00	0.00	0.00	
19,900.00	90.23	359.68	11,136.31	8,695.38	-1,118.34	8,765.51	0.00	0.00	0.00	
20,000.00	90.23	359.68	11,135.90	8,795.38	-1,118.90	8,864.97	0.00	0.00	0.00	
20,100.00	90.23	359.68	11,135.50	8,895.37	-1,119.46	8,964.43	0.00	0.00	0.00	
20,200.00	90.23	359.68	11,135.10	8,995.37	-1,120.02	9,063.89	0.00	0.00	0.00	
20,300.00	90.23	359.68	11,134.69	9,095.37	-1,120.59	9,163.35	0.00	0.00	0.00	
20,400.00	90.23	359.68	11,134.29	9,195.37	-1,121.15	9,262.81	0.00	0.00	0.00	
20,500.00	90.23	359.68	11,133.88	9,295.36	-1,121.71	9,362.27	0.00	0.00	0.00	
20,600.00	90.23	359.68	11,133.48	9,395.36	-1,122.27	9,461.73	0.00	0.00	0.00	
20,700.00	90.23	359.68	11,133.07	9,495.36	-1,122.83	9,561.19	0.00	0.00	0.00	
20,800.00	90.23	359.68	11,132.67	9,595.36	-1,123.40	9,660.65	0.00	0.00	0.00	
20,900.00	90.23	359.68	11,132.26	9,695.36	-1,123.96	9,760.11	0.00	0.00	0.00	
21,000.00	90.23	359.68	11,131.86	9,795.35	-1,124.52	9,859.57	0.00	0.00	0.00	
21,100.00	90.23	359.68	11,131.45	9,895.35	-1,125.08	9,959.04	0.00	0.00	0.00	
21,200.00	90.23	359.68	11,131.05	9,995.35	-1,125.64	10,058.50	0.00	0.00	0.00	
21,300.00	90.23	359.68	11,130.64	10,095.35	-1,126.21	10,157.96	0.00	0.00	0.00	
21,400.00	90.23	359.68	11,130.24	10,195.34	-1,126.77	10,257.42	0.00	0.00	0.00	
21,459.16	90.23	359.68	11,130.00	10,254.50	-1,127.10	10,316.26	0.00	0.00	0.00	
PBHL										

Design Targets										
Target Name	Dip Angle (°)	Dip Dir. (°)	TVD (usft)	+N/-S (usft)	+E/-W (usft)	Northing (usft)	Easting (usft)	Latitude	Longitude	
VP/ KOP - Bilbrey 34/ - plan hits target center - Point	0.00	0.00	10,397.05	-207.20	-1,068.30	520,096.10	748,772.00	32.428016	-103.661029	
PBHL - Bilbrey 34/27 - plan hits target center - Point	0.00	0.00	11,130.00	10,254.50	-1,127.10	530,557.80	748,713.20	32.456773	-103.661006	



Stryker Directional
Planning Report



Database:	EDM 5000 Server	Local Co-ordinate Reference:	Well Bilbrey 34/27 Fed Com 555H
Company:	Mewbourne Oil Company	TVD Reference:	RKB @ 3740.00usft (Patterson 560)
Project:	Lea County, NM (NAD83) NMEZ Grid	MD Reference:	RKB @ 3740.00usft (Patterson 560)
Site:	Bilbrey 34/27	North Reference:	Grid
Well:	Bilbrey 34/27 Fed Com 555H	Survey Calculation Method:	Minimum Curvature
Wellbore:	Wellbore #1		
Design:	Design #1		

Formations						
Measured Depth (usft)	Vertical Depth (usft)	Name	Lithology	Dip (°)	Dip Direction (°)	
882.00	882.00	Rustler		-0.23	353.73	
1,195.00	1,195.00	Salt Top		-0.23	353.73	
1,750.00	1,750.00	MB-126		-0.23	353.73	
4,849.45	4,825.21	Salt Base		-0.23	353.73	
4,893.86	4,869.21	Delaware (Lamar)		-0.23	353.73	
5,009.92	4,984.21	Bell Canyon		-0.23	353.73	
5,884.92	5,851.24	Cherry Canyon		-0.23	353.73	
6,049.42	6,014.24	Manzanita Marker		-0.23	353.73	
8,607.81	8,549.31	Basal Brushy Canyon		-0.23	353.73	
8,871.22	8,810.32	Bone Spring		-0.23	353.73	
9,938.98	9,868.35	1st Bone Spring Sand		-0.23	353.73	
10,600.48	10,527.36	2nd Bone Spring Sand		-0.23	353.73	

Plan Annotations					
Measured Depth (usft)	Vertical Depth (usft)	Local Coordinates		Comment	
		+N/-S (usft)	+E/-W (usft)		
1,900.00	1,900.00	0.00	0.00	Begin 2.00°/100' Build	
2,287.00	2,285.82	-21.64	-14.59	Hold 7.74° Inc, Begin 2.00°/100' Turn	
2,593.76	2,590.08	-42.08	-46.57	Hold 260.82° Azi	
10,083.08	10,011.14	-203.03	-1,042.52	Begin 2.00°/100' Drop	
10,470.17	10,397.05	-207.20	-1,068.30	Begin Vertical Hold	
10,670.17	10,597.05	-207.20	-1,068.30	KOP, Begin 10.00°/100' Build	
11,572.49	11,170.00	368.07	-1,071.53	Begin 90.23° Lateral	
21,459.16	11,130.00	10,254.50	-1,127.10	PBHL	

Sante Fe Main Office
Phone: (505) 476-3441

General Information
Phone: (505) 629-6116

Online Phone Directory
<https://www.emnrd.nm.gov/ocd/contact-us>

State of New Mexico
Energy, Minerals and Natural Resources
Oil Conservation Division
1220 S. St Francis Dr.
Santa Fe, NM 87505

CONDITIONS

Action 553303

CONDITIONS

Operator: MEWBOURNE OIL CO P.O. Box 5270 Hobbs, NM 88241	OGRID: 14744
	Action Number: 553303
	Action Type: [C-103] NOI Change of Plans (C-103A)

CONDITIONS

Created By	Condition	Condition Date
matthew.gomez	The C-103 NOI was not approved or rejected; however, the work requested in the C-103 NOI was performed and completed without NMOCD approval. This action will result in review for potential compliance actions.	2/17/2026
matthew.gomez	Property code is now 338818 if production exists, C-115 monthly production reports must be amended from the effective date onward.	2/17/2026
matthew.gomez	All previous COA's not addressed within the updated COA's still apply.	2/17/2026