

Form 3160-5
(October 2024)

UNITED STATES
DEPARTMENT OF THE INTERIOR
BUREAU OF LAND MANAGEMENT

FORM APPROVED
OMB No. 1004-0220
Expires: October 31, 2027

SUNDRY NOTICES AND REPORTS ON WELLS
Do not use this form for proposals to drill or to re-enter an abandoned well. Use Form 3160-3 (APD) for such proposals.

5. Lease Serial No. NMNM0560397

6. If Indian, Allottee or Tribe Name

SUBMIT IN TRIPLICATE - Other instructions on page 2

7. If Unit of CA/Agreement, Name and/or No.

1. Type of Well
 Oil Well Gas Well Other

8. Well Name and No.
CORNWALL FEDERAL/1H

2. Name of Operator MACK ENERGY CORPORATION

9. API Well No. 3000564373

3a. Address P O BOX 960, ARTESIA, NM 88211-0960

3b. Phone No. (include area code)
(575) 748-1288

10. Field and Pool or Exploratory Area
Round Tank/SAN ANDRES

4. Location of Well (Footage, Sec., T.,R.,M., or Survey Description)
SEC 19/T15S/R29E/NMP

11. Country or Parish, State
CHAVES/NM

12. CHECK THE APPROPRIATE BOX(ES) TO INDICATE NATURE OF NOTICE, REPORT OR OTHER DATA

TYPE OF SUBMISSION	TYPE OF ACTION			
<input type="checkbox"/> Notice of Intent	<input type="checkbox"/> Acidize	<input type="checkbox"/> Deepen	<input type="checkbox"/> Production (Start/Resume)	<input type="checkbox"/> Water Shut-Off
<input checked="" type="checkbox"/> Subsequent Report	<input type="checkbox"/> Alter Casing	<input type="checkbox"/> Hydraulic Fracturing	<input type="checkbox"/> Reclamation	<input type="checkbox"/> Well Integrity
<input type="checkbox"/> Final Abandonment Notice	<input type="checkbox"/> Casing Repair	<input type="checkbox"/> New Construction	<input type="checkbox"/> Recomplete	<input checked="" type="checkbox"/> Other
	<input type="checkbox"/> Change Plans	<input type="checkbox"/> Plug and Abandon	<input type="checkbox"/> Temporarily Abandon	
	<input type="checkbox"/> Convert to Injection	<input type="checkbox"/> Plug Back	<input type="checkbox"/> Water Disposal	

13. Describe Proposed or Completed Operation: Clearly state all pertinent details, including estimated starting date of any proposed work and approximate duration thereof. If the proposal is to deepen directionally or recomplete horizontally, give subsurface locations and measured and true vertical depths of all pertinent markers and zones. Attach the Bond under which the work will be performed or provide the Bond No. on file with BLM/BIA. Required subsequent reports must be filed within 30 days following completion of the involved operations. If the operation results in a multiple completion or recompletion in a new interval, a Form 3160-4 must be filed once testing has been completed. Final Abandonment Notices must be filed only after all requirements, including reclamation, have been completed and the operator has determined that the site is ready for final inspection.)

Please see attached Site Facility Diagram.

Accepted for Record - Pending PET inspection

14. I hereby certify that the foregoing is true and correct. Name (Printed/Typed)
JERRY SHERRELL / Ph: (575) 748-1288

Signature (Electronic Submission)

Title Production Clerk

Date 02/06/2026

THE SPACE FOR FEDERAL OR STATE OFFICE USE

Approved by JENNIFER SANCHEZ

Digitally signed by JENNIFER SANCHEZ
Date: 2026.02.09 08:06:43 -07'00'

Title Petroleum Engineer

Office RFO

Date 02/09/2026

Conditions of approval, if any, are attached. Approval of this notice does not warrant or certify that the applicant holds legal or equitable title to those rights in the subject lease which would entitle the applicant to conduct operations thereon.

Title 18 U.S.C Section 1001 and Title 43 U.S.C Section 1212, make it a crime for any person knowingly and willfully to make to any department or agency of the United States any false, fictitious or fraudulent statements or representations as to any matter within its jurisdiction.

(Instructions on page 2)

GENERAL INSTRUCTIONS

This form is designed for submitting proposals to perform certain well operations and reports of such operations when completed as indicated on Federal and Indian lands pursuant to applicable Federal law and regulations. Any necessary special instructions concerning the use of this form and the number of copies to be submitted, particularly with regard to local area or regional procedures and practices, are either shown below, will be issued by or may be obtained from the local Federal office.

SPECIFIC INSTRUCTIONS

Item 4 - Locations on Federal or Indian land should be described in accordance with Federal requirements. Consult the local Federal office for specific instructions.

Item 13: Proposals to abandon a well and subsequent reports of abandonment should include such special information as is required by the local Federal office. In addition, such proposals and reports should include reasons for the abandonment; data on any former or present productive zones or other zones with present significant fluid contents not sealed off by cement or otherwise; depths (top and bottom) and method of placement of cement plugs; mud or other material placed below, between and above plugs; amount, size, method of parting of any casing, liner or tubing pulled and the depth to the top of any tubing left in the hole; method of closing top of well and date well site conditioned for final inspection looking for approval of the abandonment. If the proposal will involve **hydraulic fracturing operations**, you must comply with 43 CFR 3162.3-3, including providing information about the protection of usable water. Operators should provide the best available information about all formations containing water and their depths. This information could include data and interpretation of resistivity logs run on nearby wells. Information may also be obtained from state or tribal regulatory agencies and from local BLM offices.

NOTICES

The privacy Act of 1974 and the regulation in 43 CFR 2.48(d) provide that you be furnished the following information in connection with information required by this application.

AUTHORITY: 30 U.S.C. 181 et seq., 351 et seq., 25 U.S.C. 396; 43 CFR 3160.

PRINCIPAL PURPOSE: The information is used to: (1) Evaluate, when appropriate, approve applications, and report completion of subsequent well operations, on a Federal or Indian lease; and (2) document for administrative use, information for the management, disposal and use of National Resource lands and resources, such as: (a) evaluating the equipment and procedures to be used during a proposed subsequent well operation and reviewing the completed well operations for compliance with the approved plan; (b) requesting and granting approval to perform those actions covered by 43 CFR 3162.3-2, 3162.3-3, and 3162.3-4; (c) reporting the beginning or resumption of production, as required by 43 CFR 3162.4-1(c) and (d) analyzing future applications to drill or modify operations in light of data obtained and methods used.

ROUTINE USES: Information from the record and/or the record will be transferred to appropriate Federal, State, local or foreign agencies, when relevant to civil, criminal or regulatory investigations or prosecutions in connection with congressional inquiries or to consumer reporting agencies to facilitate collection of debts owed the Government.

EFFECT OF NOT PROVIDING THE INFORMATION: Filing of this notice and report and disclosure of the information is mandatory for those subsequent well operations specified in 43 CFR 3162.3-2, 3162.3-3, 3162.3-4.

The Paperwork Reduction Act of 1995 requires us to inform you that:

The BLM collects this information to evaluate proposed and/or completed subsequent well operations on Federal or Indian oil and gas leases.

Response to this request is mandatory.

The BLM would like you to know that you do not have to respond to this or any other Federal agency-sponsored information collection unless it displays a currently valid OMB control number.

BURDEN HOURS STATEMENT: Public reporting burden for this form is estimated to average 8 hours per response, including the time for reviewing instructions, gathering and maintaining data, and completing and reviewing the form. Direct comments regarding the burden estimate or any other aspect of this form to U.S. Department of the Interior, Bureau of Land Management (1004-0137), Bureau Information Collection Clearance Officer (WO-630), 1849 C St., N.W., Mail Stop 401 LS, Washington, D.C. 20240

Additional Information

Location of Well

0. SHL: SESE / 660 FSL / 990 FEL / TWSP: 15S / RANGE: 29E / SECTION: 19 / LAT: 32.9959797 / LONG: -104.0624502 (TVD: 0 feet, MD: 0 feet)

PPP: NENE / 106 FNL / 1004 FEL / TWSP: 15S / RANGE: 29E / SECTION: 30 / LAT: 32.993874 / LONG: -104.0624956 (TVD: 0 feet, MD: 0 feet)

BHL: SESE / 3 FSL / 999 FEL / TWSP: 15S / RANGE: 29E / SECTION: 30 / LAT: 32.9797474 / LONG: -104.0627088 (TVD: 0 feet, MD: 0 feet)

CONFIDENTIAL

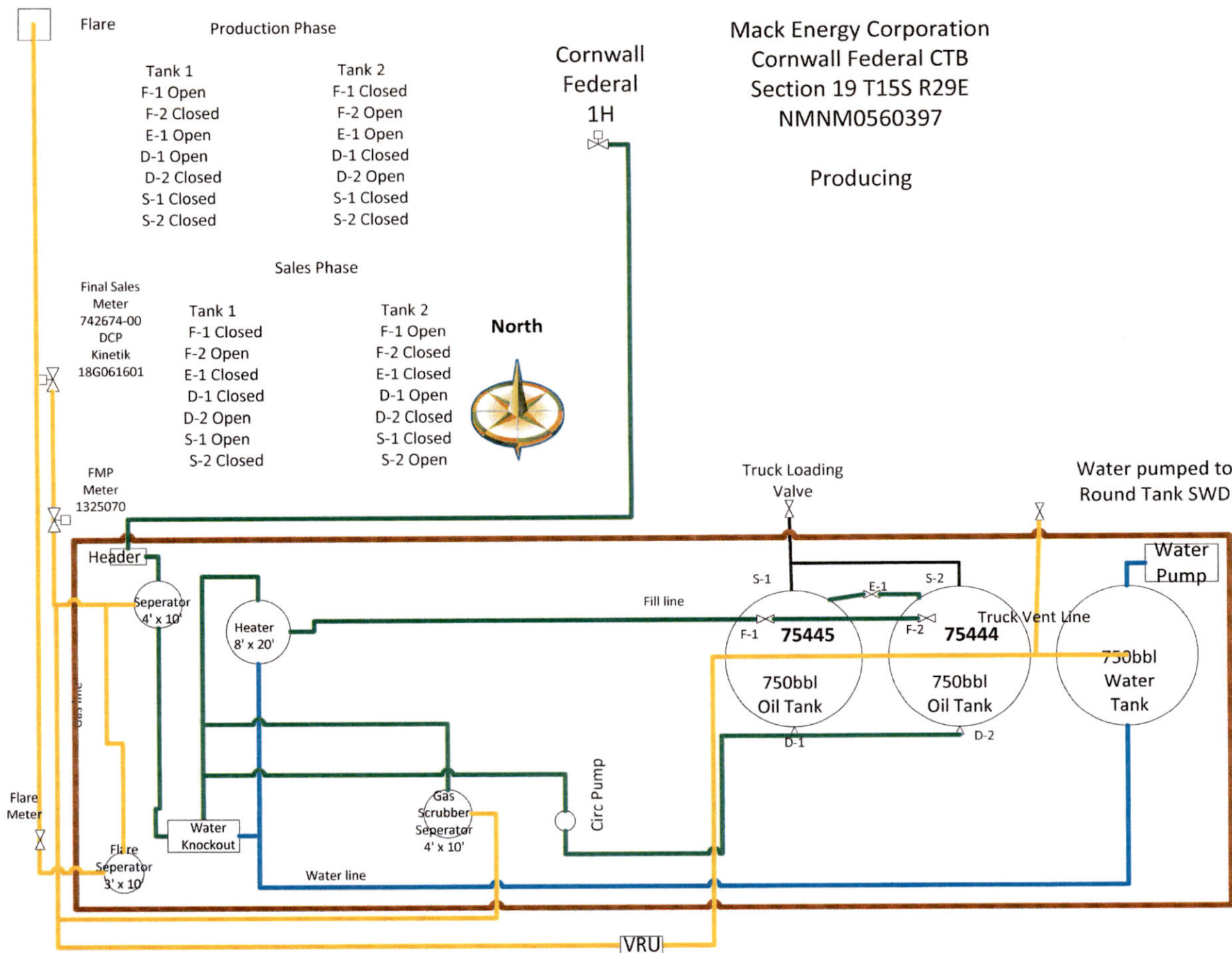

U.S. Department of the Interior
BUREAU OF LAND MANAGEMENT

02/09/2026

Well Name: CORNWALL FEDERAL	Well Location: T15S / R29E / SEC 19 / SESE / 32.9959797 / -104.0624502	County or Parish/State: CHAVES / NM
Well Number: 1H	Type of Well: OIL WELL	Allottee or Tribe Name:
Lease Number: NMNM0560397	Unit or CA Name:	Unit or CA Number:
US Well Number: 3000564373	Operator: MACK ENERGY CORPORATION	

Subsequent Report

Sundry ID: 2894788

Type of Submission: Subsequent Report

Type of Action: Site Facility Diagram/Site Security Plan

Date Sundry Submitted: 02/06/2026

Time Sundry Submitted: 11:50

Date Operation Actually Began: 02/06/2026

Actual Procedure: Please see attached Site Facility Diagram.

SR Attachments

Actual Procedure

Cornwall_CTB_20260206115010.pdf

Well Name: CORNWALL FEDERAL	Well Location: T15S / R29E / SEC 19 / SESE / 32.9959797 / -104.0624502	County or Parish/State: CHAVES / NM
Well Number: 1H	Type of Well: OIL WELL	Allottee or Tribe Name:
Lease Number: NMNM0560397	Unit or CA Name:	Unit or CA Number:
US Well Number: 3000564373	Operator: MACK ENERGY CORPORATION	

Operator

I certify that the foregoing is true and correct. Title 18 U.S.C. Section 1001 and Title 43 U.S.C. Section 1212, make it a crime for any person knowingly and willfully to make to any department or agency of the United States any false, fictitious or fraudulent statements or representations as to any matter within its jurisdiction. Electronic submission of Sundry Notices through this system satisfies regulations requiring a

Operator Electronic Signature: JERRY SHERRELL

Signed on: FEB 06, 2026 11:50 AM

Name: MACK ENERGY CORPORATION

Title: Production Clerk

Street Address: 11344 Lovington HWY

City: Artesia

State: NM

Phone: (575) 748-1288

Email address: jerrys@mec.com

Field

Representative Name:

Street Address:

City:

State:

Zip:

Phone:

Email address:

BLM Point of Contact

BLM POC Name: JENNIFER SANCHEZ

BLM POC Title: Petroleum Engineer

BLM POC Phone: 5756270237

BLM POC Email Address: J1SANCHEZ@BLM.GOV

Disposition: Accepted

Disposition Date: 02/09/2026

Signature: Jennifer Sanchez

Sante Fe Main Office
Phone: (505) 476-3441

General Information
Phone: (505) 629-6116

Online Phone Directory
<https://www.emnrd.nm.gov/ocd/contact-us>

State of New Mexico
Energy, Minerals and Natural Resources
Oil Conservation Division
1220 S. St Francis Dr.
Santa Fe, NM 87505

CONDITIONS

Action 552223

CONDITIONS

Operator: MACK ENERGY CORP P.O. Box 960 Artesia, NM 882110960	OGRID: 13837
	Action Number: 552223
	Action Type: [C-103] Sub. General Sundry (C-103Z)

CONDITIONS

Created By	Condition	Condition Date
dmcclure	ACCEPTED FOR RECORD ONLY	2/27/2026
dmcclure	No surface commingling or any other approval is granted via this sundry being accepted for record.	2/27/2026