

Well Name	Well Number	US Well Number	Lease Number	Case Number	Operator
Chincoteague 8-	731H	3002552996	NMLC061873B	NMLC061873B	DEVON
Chincoteague 8-	831H	3002553000	NMLC061873B	NMLC061873B	DEVON
Chincoteague 8-	622H	3002552995	NMLC061873B	NMLC061873B	DEVON
Chincoteague 8-	822H	3002552998	NMLC061873B	NMLC061873B	DEVON
CHINCOTEAGUE	332H	3002552976	NMLC061873B	NMLC061873B	DEVON
CHINCOTEAGUE	711H	3002552972	NMLC061873B	NMLC061873B	DEVON
CHINCOTEAGUE	821H	3002552979	NMLC061873B	NMLC061873B	DEVON
CHINCOTEAGUE	621H	3002552969	NMLC061873B	NMLC061873B	DEVON
CHINCOTEAGUE	331H	3002552997	NMLC061873B	NMLC061873B	DEVON
CHINCOTEAGUE	333H	3002552980	NMLC061873B	NMLC061873B	DEVON
CHINCOTEAGUE	712H	3002552973	NMLC061873B	NMLC061873B	DEVON
CHINCOTEAGUE	334H	3002552970	NMLC061873B	NMLC061873B	DEVON
CHINCOTEAGUE	732H	3002552977	NMLC061873B	NMLC061873B	DEVON
Chincoteague 8-	300H	3002552994	NMLC061873B	NMLC061873B	DEVON

Notice of Intent

Sundry ID: 2892140

Type of Submission: Notice of Intent

Type of Action: Other

Date Sundry Submitted: 01/21/2026

Time Sundry Submitted: 10:40

Date proposed operation will begin: 01/21/2026

Procedure Description: Sundry submittal at request of CFO. Devon Energy Production Co., L.P. (Devon) respectfully requests approval for a gas lift system regarding the subject wells. Gas will go into a pipeline system designed for gas injection for gas lift systems installed on wells from various reservoirs and leases. Each well within the system will be equipped with an individual injection meter, enabling tracking of injection volumes separate from the gas production of each well. The projected injection volumes are approximately 1,140 MCF per day for each well. Devon acknowledges that this gas is not royalty-free and the concept of beneficial use does not apply in this context. Please see attached supporting documentation.

Surface Disturbance

Is any additional surface disturbance proposed?: No

NOI Attachments

Procedure Description

MUSTANG_CHINCOTEAGUE_MESH_GL_PFD_20260121103915.pdf

Operator

I certify that the foregoing is true and correct. Title 18 U.S.C. Section 1001 and Title 43 U.S.C. Section 1212, make it a crime for any person knowingly and willfully to make to any department or agency of the United States any false, fictitious or fraudulent statements or representations as to any matter within its jurisdiction. Electronic submission of Sundry Notices through this system satisfies regulations requiring a

Operator Electronic Signature: AMY BROWN

Signed on: JAN 21, 2026 10:39 AM

Name: DEVON ENERGY PRODUCTION COMPANY LP

Title: Regulatory Professional

Street Address: 333 WEST SHERIDAN AVENUE

City: OKLAHOMA CITY **State:** OK

Phone: (405) 552-6137

Email address: AMY.BROWN@DVN.COM

Field

Representative Name:

Street Address:

City: **State:** **Zip:**

Phone:

Email address:

BLM Point of Contact

BLM POC Name: JONATHON W SHEPARD

BLM POC Title: Petroleum Engineer

BLM POC Phone: 5752345972

BLM POC Email Address: jshepard@blm.gov

Disposition: Approved

Disposition Date: 02/26/2026

Signature: Jonathon Shepard

Form 3160-5
(October 2024)

UNITED STATES
DEPARTMENT OF THE INTERIOR
BUREAU OF LAND MANAGEMENT

FORM APPROVED
OMB No. 1004-0220
Expires: October 31, 2027

SUNDRY NOTICES AND REPORTS ON WELLS
Do not use this form for proposals to drill or to re-enter an abandoned well. Use Form 3160-3 (APD) for such proposals.

5. Lease Serial No.

6. If Indian, Allottee or Tribe Name

SUBMIT IN TRIPLICATE - Other instructions on page 2

7. If Unit of CA/Agreement, Name and/or No.

1. Type of Well

Oil Well Gas Well Other

8. Well Name and No.

2. Name of Operator

9. API Well No.

3a. Address

3b. Phone No. (include area code)

10. Field and Pool or Exploratory Area

4. Location of Well (Footage, Sec., T.,R.,M., or Survey Description)

11. Country or Parish, State

12. CHECK THE APPROPRIATE BOX(ES) TO INDICATE NATURE OF NOTICE, REPORT OR OTHER DATA

TYPE OF SUBMISSION	TYPE OF ACTION			
<input type="checkbox"/> Notice of Intent	<input type="checkbox"/> Acidize	<input type="checkbox"/> Deepen	<input type="checkbox"/> Production (Start/Resume)	<input type="checkbox"/> Water Shut-Off
<input type="checkbox"/> Subsequent Report	<input type="checkbox"/> Alter Casing	<input type="checkbox"/> Hydraulic Fracturing	<input type="checkbox"/> Reclamation	<input type="checkbox"/> Well Integrity
<input type="checkbox"/> Final Abandonment Notice	<input type="checkbox"/> Casing Repair	<input type="checkbox"/> New Construction	<input type="checkbox"/> Recomplete	<input type="checkbox"/> Other
	<input type="checkbox"/> Change Plans	<input type="checkbox"/> Plug and Abandon	<input type="checkbox"/> Temporarily Abandon	
	<input type="checkbox"/> Convert to Injection	<input type="checkbox"/> Plug Back	<input type="checkbox"/> Water Disposal	

13. Describe Proposed or Completed Operation: Clearly state all pertinent details, including estimated starting date of any proposed work and approximate duration thereof. If the proposal is to deepen directionally or recomplete horizontally, give subsurface locations and measured and true vertical depths of all pertinent markers and zones. Attach the Bond under which the work will be performed or provide the Bond No. on file with BLM/BIA. Required subsequent reports must be filed within 30 days following completion of the involved operations. If the operation results in a multiple completion or recompletion in a new interval, a Form 3160-4 must be filed once testing has been completed. Final Abandonment Notices must be filed only after all requirements, including reclamation, have been completed and the operator has determined that the site is ready for final inspection.)

14. I hereby certify that the foregoing is true and correct. Name (Printed/Typed)

Title

Signature

Date

THE SPACE FOR FEDERAL OR STATE OFFICE USE

Approved by

Title

Date

Conditions of approval, if any, are attached. Approval of this notice does not warrant or certify that the applicant holds legal or equitable title to those rights in the subject lease which would entitle the applicant to conduct operations thereon.

Office

Title 18 U.S.C Section 1001 and Title 43 U.S.C Section 1212, make it a crime for any person knowingly and willfully to make to any department or agency of the United States any false, fictitious or fraudulent statements or representations as to any matter within its jurisdiction.

(Instructions on page 2)

GENERAL INSTRUCTIONS

This form is designed for submitting proposals to perform certain well operations and reports of such operations when completed as indicated on Federal and Indian lands pursuant to applicable Federal law and regulations. Any necessary special instructions concerning the use of this form and the number of copies to be submitted, particularly with regard to local area or regional procedures and practices, are either shown below, will be issued by or may be obtained from the local Federal office.

SPECIFIC INSTRUCTIONS

Item 4 - Locations on Federal or Indian land should be described in accordance with Federal requirements. Consult the local Federal office for specific instructions.

Item 13: Proposals to abandon a well and subsequent reports of abandonment should include such special information as is required by the local Federal office. In addition, such proposals and reports should include reasons for the abandonment; data on any former or present productive zones or other zones with present significant fluid contents not sealed off by cement or otherwise; depths (top and bottom) and method of placement of cement plugs; mud or other material placed below, between and above plugs; amount, size, method of parting of any casing, liner or tubing pulled and the depth to the top of any tubing left in the hole; method of closing top of well and date well site conditioned for final inspection looking for approval of the abandonment. If the proposal will involve **hydraulic fracturing operations**, you must comply with 43 CFR 3162.3-3, including providing information about the protection of usable water. Operators should provide the best available information about all formations containing water and their depths. This information could include data and interpretation of resistivity logs run on nearby wells. Information may also be obtained from state or tribal regulatory agencies and from local BLM offices.

NOTICES

The privacy Act of 1974 and the regulation in 43 CFR 2.48(d) provide that you be furnished the following information in connection with information required by this application.

AUTHORITY: 30 U.S.C. 181 et seq., 351 et seq., 25 U.S.C. 396; 43 CFR 3160.

PRINCIPAL PURPOSE: The information is used to: (1) Evaluate, when appropriate, approve applications, and report completion of subsequent well operations, on a Federal or Indian lease; and (2) document for administrative use, information for the management, disposal and use of National Resource lands and resources, such as: (a) evaluating the equipment and procedures to be used during a proposed subsequent well operation and reviewing the completed well operations for compliance with the approved plan; (b) requesting and granting approval to perform those actions covered by 43 CFR 3162.3-2, 3162.3-3, and 3162.3-4; (c) reporting the beginning or resumption of production, as required by 43 CFR 3162.4-1(c) and (d) analyzing future applications to drill or modify operations in light of data obtained and methods used.

ROUTINE USES: Information from the record and/or the record will be transferred to appropriate Federal, State, local or foreign agencies, when relevant to civil, criminal or regulatory investigations or prosecutions in connection with congressional inquiries or to consumer reporting agencies to facilitate collection of debts owed the Government.

EFFECT OF NOT PROVIDING THE INFORMATION: Filing of this notice and report and disclosure of the information is mandatory for those subsequent well operations specified in 43 CFR 3162.3-2, 3162.3-3, 3162.3-4.

The Paperwork Reduction Act of 1995 requires us to inform you that:

The BLM collects this information to evaluate proposed and/or completed subsequent well operations on Federal or Indian oil and gas leases.

Response to this request is mandatory.

The BLM would like you to know that you do not have to respond to this or any other Federal agency-sponsored information collection unless it displays a currently valid OMB control number.

BURDEN HOURS STATEMENT: Public reporting burden for this form is estimated to average 8 hours per response, including the time for reviewing instructions, gathering and maintaining data, and completing and reviewing the form. Direct comments regarding the burden estimate or any other aspect of this form to U.S. Department of the Interior, Bureau of Land Management (1004-0137), Bureau Information Collection Clearance Officer (WO-630), 1849 C St., N.W., Mail Stop 401 LS, Washington, D.C. 20240

Additional Information

Batch Well Data

CHINCOTEAGUE 8-32 FED STATE COM 711H, US Well Number: 3002552972, Case Number: NMLC061873B, Lease Number: NMLC061873B,
Operator:DEVON ENERGY PRODUCTION COMPANY LP

CHINCOTEAGUE 8-32 FED STATE COM 712H, US Well Number: 3002552973, Case Number: NMLC061873B, Lease Number: NMLC061873B,
Operator:DEVON ENERGY PRODUCTION COMPANY LP

CHINCOTEAGUE 8-32 FED STATE COM 821H, US Well Number: 3002552979, Case Number: NMLC061873B, Lease Number: NMLC061873B,
Operator:DEVON ENERGY PRODUCTION COMPANY LP

CHINCOTEAGUE 8-32 FED STATE COM 332H, US Well Number: 3002552976, Case Number: NMLC061873B, Lease Number: NMLC061873B,
Operator:DEVON ENERGY PRODUCTION COMPANY LP

CHINCOTEAGUE 8-32 FED STATE COM 621H, US Well Number: 3002552969, Case Number: NMLC061873B, Lease Number: NMLC061873B,
Operator:DEVON ENERGY PRODUCTION COMPANY LP

CHINCOTEAGUE 8-32 FED STATE COM 333H, US Well Number: 3002552980, Case Number: NMLC061873B, Lease Number: NMLC061873B,
Operator:DEVON ENERGY PRODUCTION COMPANY LP

CHINCOTEAGUE 8-32 FED STATE COM 334H, US Well Number: 3002552970, Case Number: NMLC061873B, Lease Number: NMLC061873B,
Operator:DEVON ENERGY PRODUCTION COMPANY LP

CHINCOTEAGUE 8-32 FED STATE COM 732H, US Well Number: 3002552977, Case Number: NMLC061873B, Lease Number: NMLC061873B,
Operator:DEVON ENERGY PRODUCTION COMPANY LP

Chincoteague 8-32 Fed Com 300H, US Well Number: 3002552994, Case Number: NMLC061873B, Lease Number: NMLC061873B,
Operator:DEVON ENERGY PRODUCTION COMPANY LP

CHINCOTEAGUE 8-32 FED STATE COM 331H, US Well Number: 3002552997, Case Number: NMLC061873B, Lease Number: NMLC061873B,
Operator:DEVON ENERGY PRODUCTION COMPANY LP

Chincoteague 8-32 Fed State Com 731H, US Well Number: 3002552996, Case Number: NMLC061873B, Lease Number: NMLC061873B,
Operator:DEVON ENERGY PRODUCTION COMPANY LP

Chincoteague 8-32 Fed State Com 831H, US Well Number: 3002553000, Case Number: NMLC061873B, Lease Number: NMLC061873B,
Operator:DEVON ENERGY PRODUCTION COMPANY LP

Chincoteague 8-32 Fed State Com 622H, US Well Number: 3002552995, Case Number: NMLC061873B, Lease Number: NMLC061873B,
Operator:DEVON ENERGY PRODUCTION COMPANY LP

Chincoteague 8-32 Fed State Com 822H, US Well Number: 3002552998, Case Number: NMLC061873B, Lease Number: NMLC061873B,

Operator:DEVON ENERGY PRODUCTION COMPANY LP

CONFIDENTIAL

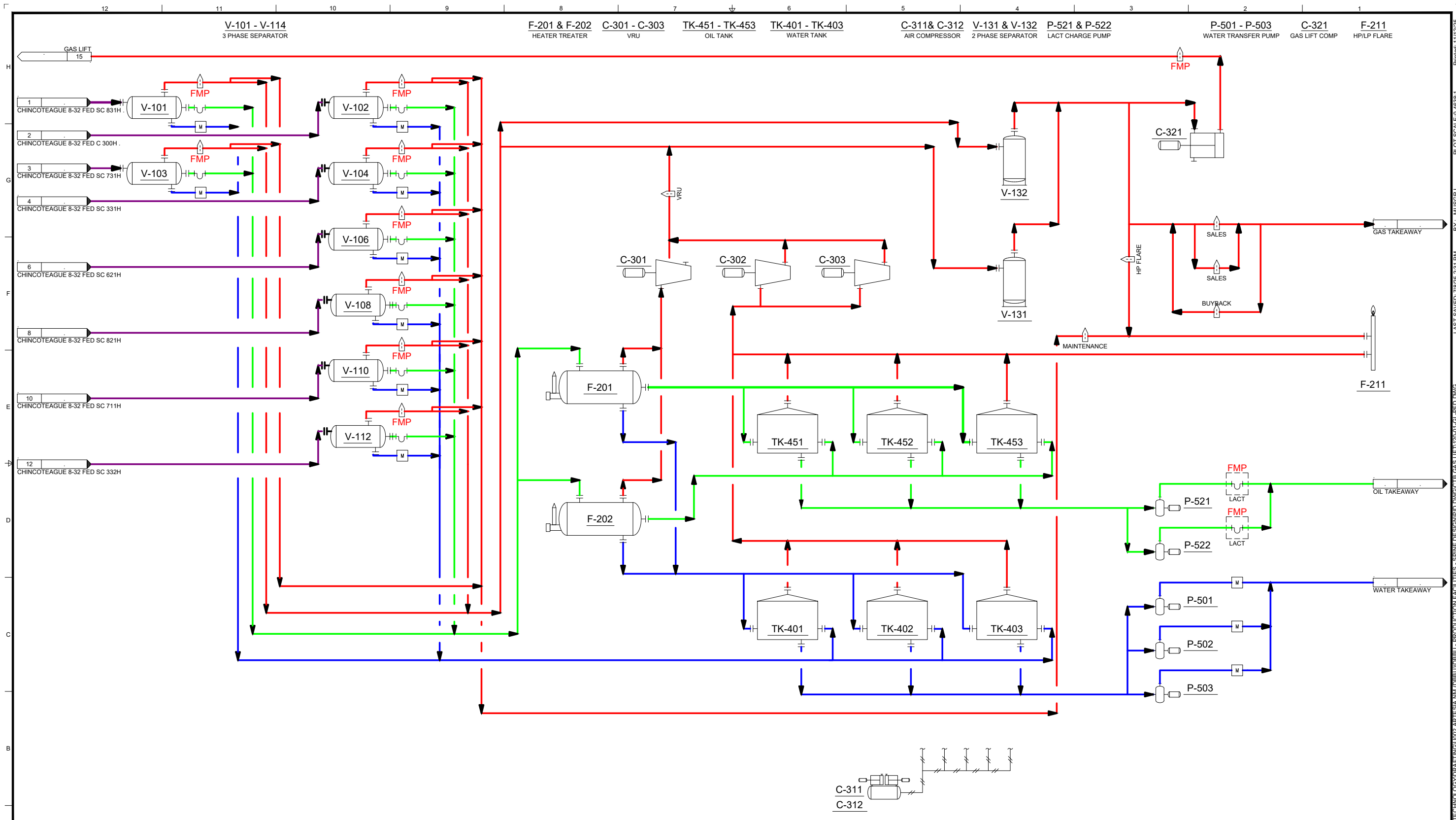

NOTES:

- ORIFICE METER
- CORIOLIS METER
- MAGNETIC METER
- GAS
- OIL
- WATER
- FULL WELL STREAM
- INSTRUMENT AIR
- FEDERAL MEASUREMENT POINT

REV	DESCRIPTION	DATE	DRAWN	APPROV
A	INITIAL RELEASE		KR	PM

LAT. / LONG. COORDINATES		DATE:
GPS: N. _____ -W. _____		11/1/25
DRAWN BY: KR		DATE:
ENGINEERED BY: PM		11/1/25
WBS PROJECT No.: 120		DRAWING No.:
120-02-PFD.dwg		



Devon Energy Corporation
 333 West Sheridan Avenue, Oklahoma City, OK 73102-5015

DBBU - SPINE DESIGN - REV 3.1
 PROCESS FLOW DIAGRAM
 MUSTANG 8 CTB 1

FILE NAME: 120-02-PFD
 DWG REV: A

PLOT SCALE: 0.4638:1
 BY: MUSGRJ
 LAST SAVED: 7/8/25 2:31 PM
 W:\USACORPORATE\ENGINEERING\TECHNOLOGY\DRAWING\002 ARTESIA\NM\08BU\DBBU - PRODUCTION FACILITIES - SPINE DESIGN\120-02-PFD.dwg

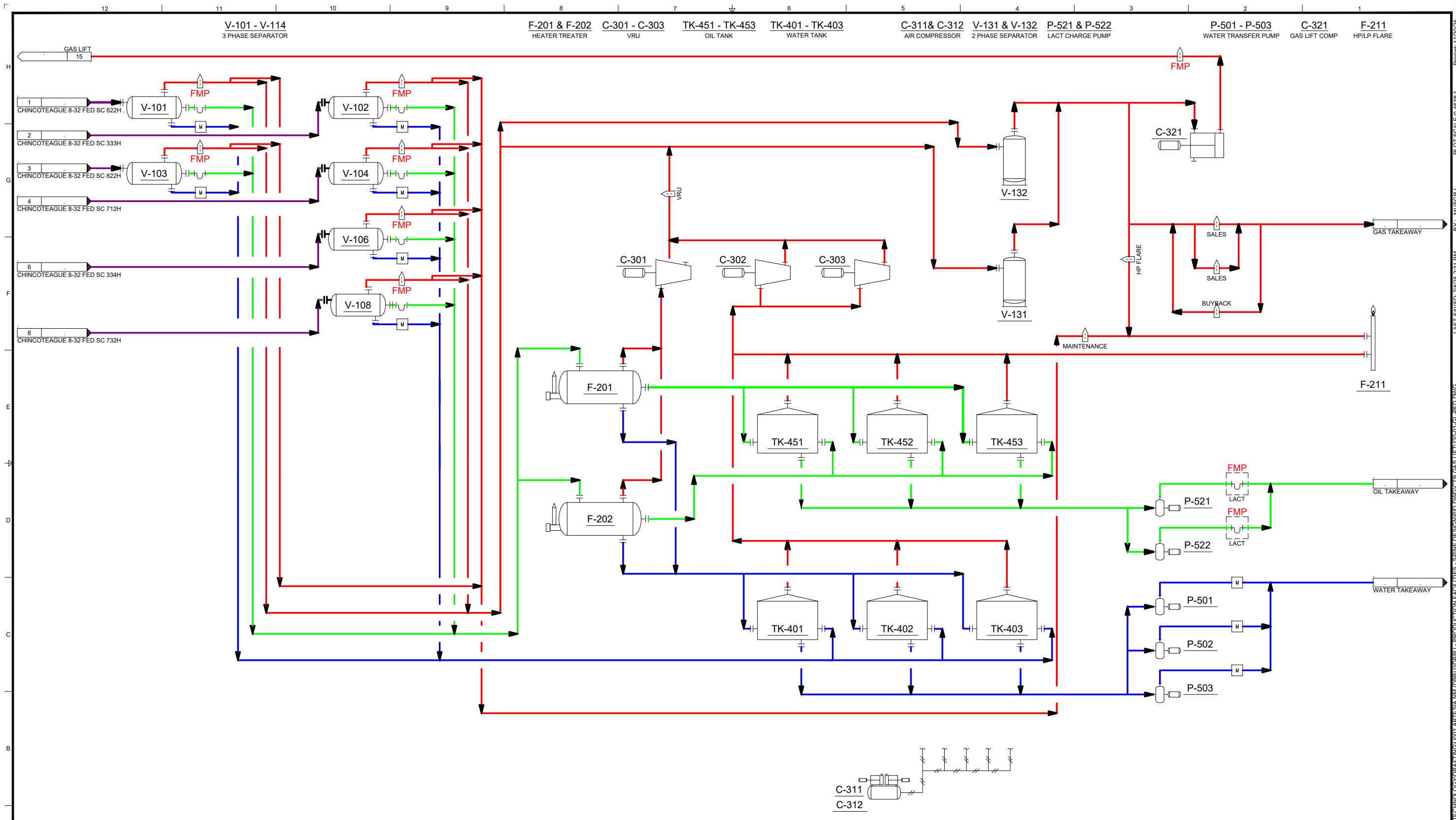

- NOTES:**
- ORIFICE METER
 - CORIOLIS METER
 - MAGNETIC METER
 - GAS
 - OIL
 - WATER
 - FULL WELL STREAM
 - INSTRUMENT AIR
 - FEDERAL MEASUREMENT POINT

REV	DESCRIPTION	DATE	DRAWN	APPROV
A	INITIAL RELEASE		KR	PM

LAT. / LONG. COORDINATES		DATE:
GPS: N. _____ -W. _____		11/1/25
DRAWN BY: KR		DATE: 11/1/25
ENGINEERED BY: PM		
WBS PROJECT No.: 120		
DRAWING No.: 120-02-PFD.dwg		



Devon Energy Corporation
 333 West Sheridan Avenue, Oklahoma City, OK 73102-5015

DBBU - SPINE DESIGN - REV 3.1
 PROCESS FLOW DIAGRAM
 MUSTANG 8 CTB 2

FILE NAME: 120-02-PFD
 DWG REV: A

PLOT SCALE: 0.4638:1
 BY: MUSGRJ
 LAST SAVED: 7/8/25 2:31 PM
 W:\USACORPORATE\ENGINEERING\TECHNOLOGY\DRAWING\002 ARTESIA\NM\08BU\08BU - PRODUCTION FACILITIES - SPINE DESIGN\120-02-PFD.DWG

Sante Fe Main Office
Phone: (505) 476-3441

General Information
Phone: (505) 629-6116

Online Phone Directory
<https://www.emnrd.nm.gov/oecd/contact-us>

State of New Mexico
Energy, Minerals and Natural Resources
Oil Conservation Division
1220 S. St Francis Dr.
Santa Fe, NM 87505

CONDITIONS

Action 559369

CONDITIONS

Operator: DEVON ENERGY PRODUCTION COMPANY, LP 333 West Sheridan Ave. Oklahoma City, OK 73102	OGRID: 6137
	Action Number: 559369
	Action Type: [C-103] NOI General Sundry (C-103X)

CONDITIONS

Created By	Condition	Condition Date
dmcclure	ACCEPTED FOR RECORD ONLY. No later than 30 days after the initial installation of artificial lift in a well or altering the type of artificial lift in a well thereafter, the operator shall submit a subsequent report to the Division detailing that work in accordance with 19.15.7.14 NMAC. The subsequent report shall be submitted as a [C-103] Sub. Workover (C-103R).	3/13/2026