

Form 3160-3
(October 2024)

FORM APPROVED
OMB No. 1004-0220
Expires: October 31, 2027

UNITED STATES
DEPARTMENT OF THE INTERIOR
BUREAU OF LAND MANAGEMENT
APPLICATION FOR PERMIT TO DRILL OR REENTER

1a. Type of work: <input type="checkbox"/> DRILL <input type="checkbox"/> REENTER		5. Lease Serial No.
1b. Type of Well: <input type="checkbox"/> Oil Well <input type="checkbox"/> Gas Well <input type="checkbox"/> Other		6. If Indian, Allottee or Tribe Name
1c. Type of Completion: <input type="checkbox"/> Hydraulic Fracturing <input type="checkbox"/> Single Zone <input type="checkbox"/> Multiple Zone		7. If Unit or CA Agreement, Name and No.
2. Name of Operator		8. Lease Name and Well No.
3a. Address		9. API Well No. 30-043-21548
3b. Phone No. (include area code)		10. Field and Pool, or Exploratory
4. Location of Well (Report location clearly and in accordance with any State requirements. *) At surface At proposed prod. zone		11. Sec., T. R. M. or Blk. and Survey or Area
14. Distance in miles and direction from nearest town or post office*		12. County or Parish
		13. State
15. Distance from proposed* location to nearest property or lease line, ft. (Also to nearest drig. unit line, if any)	16. No of acres in lease	17. Spacing Unit dedicated to this well
18. Distance from proposed location* to nearest well, drilling, completed, applied for, on this lease, ft.	19. Proposed Depth	20. BLM/BIA Bond No. in file
21. Elevations (Show whether DF, KDB, RT, GL, etc.)	22. Approximate date work will start*	23. Estimated duration
24. Attachments		

The following, completed in accordance with the requirements of Onshore Oil and Gas Order No. 1, and the Hydraulic Fracturing rule per 43 CFR 3162.3-3 (as applicable)

- | | |
|---|---|
| <ul style="list-style-type: none"> 1. Well plat certified by a registered surveyor. 2. A Drilling Plan. 3. A Surface Use Plan (if the location is on National Forest System Lands, the SUPO must be filed with the appropriate Forest Service Office). | <ul style="list-style-type: none"> 4. Bond to cover the operations unless covered by an existing bond on file (see Item 20 above). 5. Operator certification. 6. Such other site specific information and/or plans as may be requested by the BLM. |
|---|---|

25. Signature	Name (Printed/Typed)	Date
Title		
Approved by (Signature)	Name (Printed/Typed)	Date
Title		Office

Application approval does not warrant or certify that the applicant holds legal or equitable title to those rights in the subject lease which would entitle the applicant to conduct operations thereon.
Conditions of approval, if any, are attached.

Title 18 U.S.C. Section 1001 and Title 43 U.S.C. Section 1212, make it a crime for any person knowingly and willfully to make to any department or agency of the United States any false, fictitious or fraudulent statements or representations as to any matter within its jurisdiction.



(Continued on page 2)

*(Instructions on page 2)

Additional Operator Remarks

Location of Well

0. SHL: SESE / 1227 FSL / 62 FEL / TWSP: 23N / RANGE: 7W / SECTION: 28 / LAT: 36.193896 / LONG: -107.571279 (TVD: 0 feet, MD: 0 feet)

PPP: SESE / 820 FSL / 421 FEL / TWSP: 23N / RANGE: 7W / SECTION: 28 / LAT: 36.192783 / LONG: -107.572483 (TVD: 5150 feet, MD: 5276 feet)

PPP: SENW / 2474 FNL / 2618 FWL / TWSP: 23N / RANGE: 7W / SECTION: 28 / LAT: 36.1984 / LONG: -107.579993 (TVD: 5288 feet, MD: 11509 feet)

BHL: NWNW / 439 FNL / 419 FWL / TWSP: 23N / RANGE: 7W / SECTION: 28 / LAT: 36.204004 / LONG: -107.587485 (TVD: 5288 feet, MD: 11509 feet)

BLM Point of Contact

Name: CHRISTOPHER P WENMAN

Title: Natural Resource Specialist

Phone: (505) 564-7727

Email: cwenman@blm.gov

FND 2.5" BC
GLO 1948
CALC

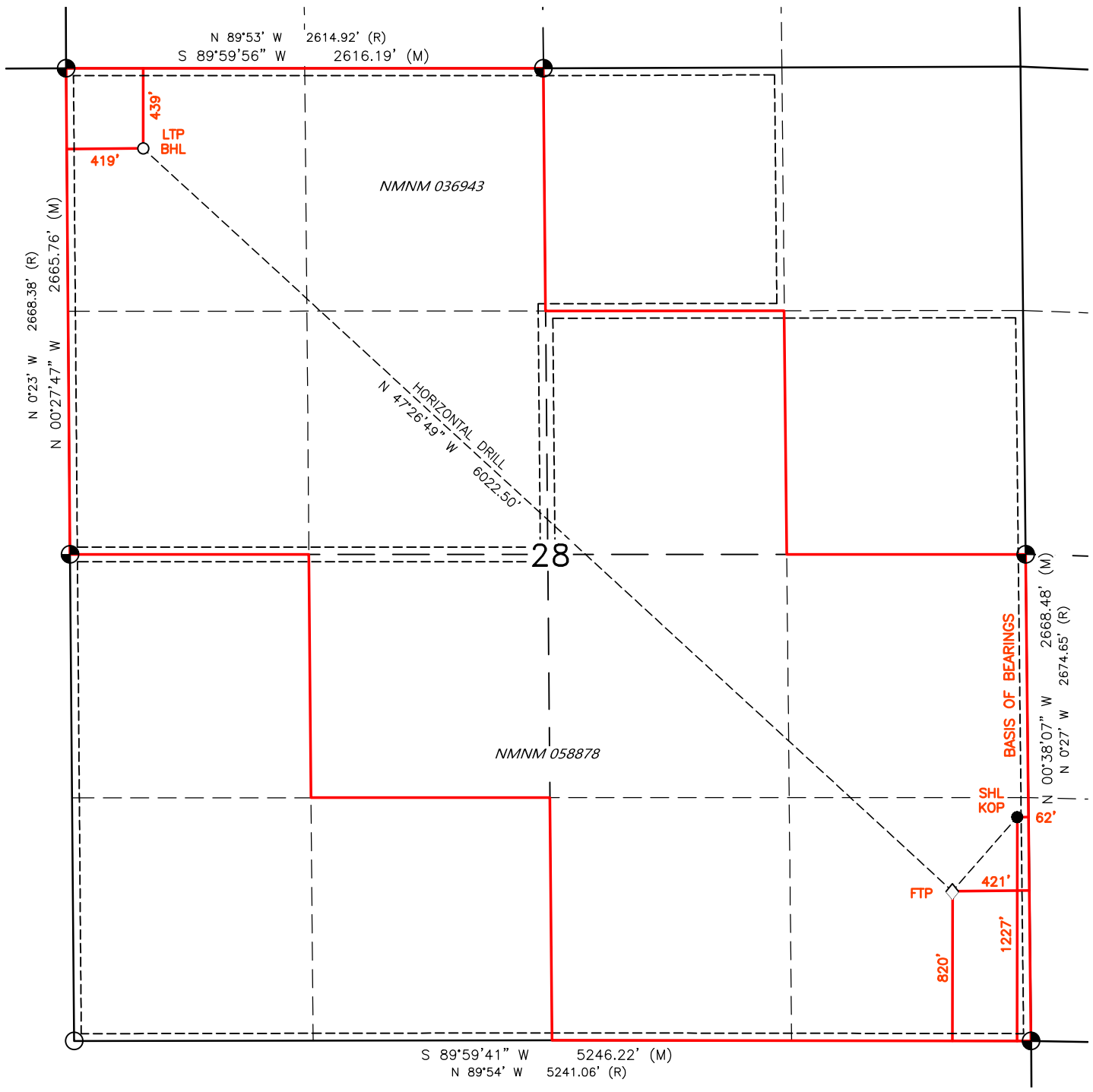

SURFACE LOCATION (SHL) ●
 1227' FSL 62' FEL
 SEC. 28, T23N, R7W
 LAT. 36.193896° N (NAD83)
 LONG. 107.571279° W (NAD83)

FIRST TAKE POINT (FTP) ◇
 820' FSL 421' FEL
 SEC. 28, T23N, R7W
 LAT. 36.192783° N (NAD83)
 LONG. 107.572483° W (NAD83)

BOTTOM HOLE LOCATION (BHL) ○
 439' FNL 419' FWL
 SEC. 28, T23N, R7W
 LAT. 36.204004° N (NAD83)
 LONG. 107.587485° W (NAD83)

KICK OFF POINT (KOP) △
 1227' FSL 62' FEL
 SEC. 28, T23N, R7W
 LAT. 36.193896° N (NAD83)
 LONG. 107.571279° W (NAD83)

LAST TAKE POINT (LTP) □
 439' FNL 419' FWL
 SEC. 28, T23N, R7W
 LAT. 36.204004° N (NAD83)
 LONG. 107.587485° W (NAD83)

State of NewMexico
Energy, Minerals and Natural Resources Department

Submit Electronically
Via E-permitting

Oil Conservation Division
1220 South St. Francis Dr.
Santa Fe, NM 87505

NATURAL GAS MANAGEMENT PLAN

This Natural Gas Management Plan must be submitted with each Application for Permit to Drill (APD) for a new or recompleted well.

Section 1 - Plan Description

Effective May 25, 2021

I. Operator: DJR Operating, LLC **OGRID:** 371838 **Date:** 2/14/2025

II. Type: Original Amendment due to 19.15.27.9.D(6)(a) NMAC 19.15.27.9.D(6)(b) NMAC Other

If Other, please describe:

III. Well(s): Provide the following information for each new or recompleted well or set of wells proposed to be drilled or proposed to be recompleted from a single well pad or connected to a central delivery point.

Well Name	API	ULSTR	Footages	Anticipated Oil BBL/D	Anticipated Gas MCF/D	Anticipated Produced Water BBL/D
N Alamito Unit 004H	TBD	P-28-23N-7W	1228 FSL 22 FEL	434	984	173
N Alamito Unit 301H	TBD	P-28-23N-7W	1228 FSL 2 FEL	374	849	150
N Alamito Unit 311H	TBD	P-28-23N-7W	1227 FSL 62 FEL	268	608	107
N Alamito Unit 312H	TBD	P-28-23N-7W	1227 FSL 42 FEL	459	1042	184
				3-year Decline	3-year Decline	3-year Decline
N Alamito Unit 004H	TBD	P-28-23N-7W	1228 FSL 22 FEL	98	392	39
N Alamito Unit 301H	TBD	P-28-23N-7W	1228 FSL 2 FEL	85	338	34
N Alamito Unit 311H	TBD	P-28-23N-7W	1227 FSL 62 FEL	61	242	24
N Alamito Unit 312H	TBD	P-28-23N-7W	1227 FSL 42 FEL	104	415	41

IV. Central Delivery Point Name: Chaco Processing Plant [See 19.15.27.9(D)(1) NMAC]

V. Anticipated Schedule: Provide the following information for each new or recompleted well or set of wells proposed to be drilled or proposed to be recompleted from a single well pad or connected to a central delivery point.

Well Name	API	Spud Date	TD Reached Date	Completion Commencement Date	Initial Flow Back Date	First Production Date
N Alamito Unit 004H	TBD	6/1/2026	6/10/2026	6/21/2026	7/1/2026	7/3/2026
N Alamito Unit 301H	TBD	6/2/2026	6/12/2026	6/21/2026	7/1/2026	7/3/2026
N Alamito Unit 311H	TBD	6/3/2026	6/13/2026	6/21/2026	7/1/2026	7/3/2026
N Alamito Unit 312H	TBD	6/4/2026	6/14/2026	6/21/2026	7/1/2026	7/3/2026

VI. Separation Equipment: Attach a complete description of how Operator will size separation equipment to optimize gas capture.

VII. Operational Practices: Attach a complete description of the actions Operator will take to comply with the requirements of Subsection A through F of 19.15.27.8 NMAC.

VIII. Best Management Practices: Attach a complete description of Operator's best management practices to minimize venting during active and planned maintenance.

Section 2 – Enhanced Plan
EFFECTIVE APRIL 1, 2022

Beginning April 1, 2022, an operator that is not in compliance with its statewide natural gas capture requirement for the applicable reporting area must complete this section.

Operator certifies that it is not required to complete this section because Operator is in compliance with its statewide natural gas capture requirement for the applicable reporting area.

IX. Anticipated Natural Gas Production:

Well	API	Anticipated Average Natural Gas Rate MCF/D	Anticipated Volume of Natural Gas for the First Year MCF

X. Natural Gas Gathering System (NGGS):

Operator	System	ULSTR of Tie-in	Anticipated Gathering Start Date	Available Maximum Daily Capacity of System Segment Tie-in

XI. Map. Attach an accurate and legible map depicting the location of the well(s), the anticipated pipeline route(s) connecting the production operations to the existing or planned interconnect of the natural gas gathering system(s), and the maximum daily capacity of the segment or portion of the natural gas gathering system(s) to which the well(s) will be connected.

XII. Line Capacity. The natural gas gathering system will will not have capacity to gather 100% of the anticipated natural gas production volume from the well prior to the date of first production.

XIII. Line Pressure. Operator does does not anticipate that its existing well(s) connected to the same segment, or portion, of the natural gas gathering system(s) described above will continue to meet anticipated increases in line pressure caused by the new well(s).

Attach Operator’s plan to manage production in response to the increased line pressure.

XIV. Confidentiality: Operator asserts confidentiality pursuant to Section 71-2-8 NMSA 1978 for the information provided in Section 2 as provided in Paragraph (2) of Subsection D of 19.15.27.9 NMAC and attaches a full description of the specific information for which confidentiality is asserted and the basis for such assertion.

Section 3 - Certifications
Effective May 25, 2021

Operator certifies that, after reasonable inquiry and based on the available information at the time of submittal:

Operator will be able to connect the well(s) to a natural gas gathering system in the general area with sufficient capacity to transport one hundred percent of the anticipated volume of natural gas produced from the well(s) commencing on the date of first production, taking into account the current and anticipated volumes of produced natural gas from other wells connected to the pipeline gathering system; or

Operator will not be able to connect to a natural gas gathering system in the general area with sufficient capacity to transport one hundred percent of the anticipated volume of natural gas produced from the well(s) commencing on the date of first production, taking into account the current and anticipated volumes of produced natural gas from other wells connected to the pipeline gathering system. ***If Operator checks this box, Operator will select one of the following:***

Well Shut-In. Operator will shut-in and not produce the well until it submits the certification required by Paragraph (4) of Subsection D of 19.15.27.9 NMAC; or

Venting and Flaring Plan. Operator has attached a venting and flaring plan that evaluates and selects one or more of the potential alternative beneficial uses for the natural gas until a natural gas gathering system is available, including:

- (a) power generation on lease;
- (b) power generation for grid;
- (c) compression on lease;
- (d) liquids removal on lease;
- (e) reinjection for underground storage;
- (f) reinjection for temporary storage;
- (g) reinjection for enhanced oil recovery;
- (h) fuel cell production; and
- (i) other alternative beneficial uses approved by the division.

Section 4 - Notices

1. If, at any time after Operator submits this Natural Gas Management Plan and before the well is spud:

(a) Operator becomes aware that the natural gas gathering system it planned to connect the well(s) to has become unavailable or will not have capacity to transport one hundred percent of the production from the well(s), no later than 20 days after becoming aware of such information, Operator shall submit for OCD's approval a new or revised venting and flaring plan containing the information specified in Paragraph (5) of Subsection D of 19.15.27.9 NMAC; or

(b) Operator becomes aware that it has, cumulatively for the year, become out of compliance with its baseline natural gas capture rate or natural gas capture requirement, no later than 20 days after becoming aware of such information, Operator shall submit for OCD's approval a new or revised Natural Gas Management Plan for each well it plans to spud during the next 90 days containing the information specified in Paragraph (2) of Subsection D of 19.15.27.9 NMAC, and shall file an update for each Natural Gas Management Plan until Operator is back in compliance with its baseline natural gas capture rate or natural gas capture requirement.

2. OCD may deny or conditionally approve an APD if Operator does not make a certification, fails to submit an adequate venting and flaring plan which includes alternative beneficial uses for the anticipated volume of natural gas produced, or if OCD determines that Operator will not have adequate natural gas takeaway capacity at the time a well will be spud.

I certify that, after reasonable inquiry, the statements in and attached to this Natural Gas Management Plan are true and correct to the best of my knowledge and acknowledge that a false statement may be subject to civil and criminal penalties under the Oil and Gas Act.

Signature: <i>Shaw-Marie Valadez</i>
Printed Name: Shaw-Marie Valadez
Title: Regulatory Specialist
E-mail Address: sford@enduringresources.com
Date: 1/6/2026
Phone: 505-716-3297
OIL CONSERVATION DIVISION (Only applicable when submitted as a standalone form)
Approved By:
Title:
Approval Date:
Conditions of Approval:



DJR Operating LLC.
OGRID No: 371838
NATURAL GAS MANAGEMENT PLAN
North Alamito Unit 004H 301H 311H 312H

SEPARATION EQUIPMENT

DJR Operating, LLC (DJR) has pulled representative pressurized samples from wells in the same producing formation. DJR has utilized these samples in process simulations to determine the amount of gas anticipated in each stage of the process and utilized this information with a safety factor to size the equipment listed below:

Separation equipment will be set as follows:

- Individual 3 phase separator will be set for the individual well.
- The separator will be sized based on the anticipated volume of the well and the pressure of the lines utilized for oil, gas, and water takeaway.
- The 3 phase production separator will be equipped with a 0.75 MMBtu/hr indirect fired heater.

Heater treaters will be set as follows:

- Individual heater treaters will be set for the individual well.
- The heater treaters are sized based on the anticipated combined volume of oil and produced water predicted to come from the initial 3 phase separator.
- Oil will be separated from the produced water and the oil/produced water will be sent to its respective tanks.
- The combined oil and natural gas stream is routed to the Vapor Recovery Tower.

Vapor Recovery Equipment will be set as follows:

- The Vapor Recovery Tower has been sized, based on the anticipated volume of gas from the heater treater and oil and water tanks.
- The Vapor Recovery Unit has been sized, based on the anticipated volume of gas from the heater treater and oil and water tanks. The Vapor Recovery Unit is utilized to push the recovered gas into the sales pipeline.

Production storage tanks will be set as follows:

- The oil and produced water tanks utilize a closed vent capture system to ensure all breathing, working, and flashing losses are routed to the Vapor Recovery Tower and Vapor Recovery Unit.
- Each of the production storage tanks will be equipped with a 0.5 MMBtu/hr indirect heater.



DJR Operating LLC.
OGRID No: 371838
NATURAL GAS MANAGEMENT PLAN
North Alamito Unit 004H 301H 311H 312H

VENTING and FLARING

DJR has a natural gas system available prior to startup of completion operations. DJR utilizes a Vapor Recovery Unit System and sells all natural gas except during periods of startup, shutdown, maintenance, or malfunction for the gas capturing equipment, including the vapor recovery tower, vapor recovery unit, storage tanks, and pipelines.

Currently, DJR utilizes the following from list A-I of Section 3 for its operations to minimize flaring:

- a) DJR utilizes natural gas-powered generators to power its leases where grid power isn't available.
- b) When electrical grid power is unavailable, natural gas generators will be used for major equipment onsite.
- c) DJR's in service compression will be natural gas powered.
- d) Should liquids removal, such as dehydration be required, units will be powered by natural gas.

DJR will only flare gas during the following times:

- o Scheduled maintenance for gas capturing equipment including:
 - o Vapor Recovery Tower
 - o Vapor Recovery Unit
 - o Storage tanks
 - o Pipelines
 - o Emergency flaring



DJR Operating LLC.
OGRID No: 371838
NATURAL GAS MANAGEMENT PLAN
North Alamito Unit 004H 301H 311H 312H

OPERATIONAL PRACTICES

19.15.27.8 A. Venting and Flaring of Natural Gas

DJR understands the requirements of NMAC 19.15.27.8 which states that the venting and flaring of natural gas during drilling, completion or production that constitutes waste as defined in 19.15.2 are prohibited.

19.15.27.8 B. Venting and flaring during drilling operations

- DJR shall capture or combust natural gas if technically feasible during drilling operations using best industry practices.
- A flare stack with a 100% capacity for expected volumes will be set on location of the facility at least 100 feet from the nearest surface hole location, well heads, and storage tanks.
- In the event of an emergency, DJR will vent natural gas in order to avoid substantial impact. DJR shall report the vented or flared gas to the NMOCD.

19.15.27.8 E. Venting and flaring during completion or recompletion operations

During Completion Operations, DJR utilizes the following:

- DJR facilities are built and ready from day 1 of Flowback.
- Individual well test separators will be set to properly separate gas and liquids. Temporary test separator will be utilized initially to process volumes. In addition, separators will be tied into flowback tanks which will be tied into the gas processing equipment for sales down a pipeline. See Separation Equipment for details.
- Should the facility not yet be capable of processing gas, or the gas does not meet quality standards, then storage tanks will be set that are tied into gas busters or temporary flare to manage natural gas. This flare would meet the following requirements:
 - 1) An appropriately sized flare stack with an automatic igniter.
 - 2) DJR analyzes the natural gas samples twice per week.
 - 3) DJR routes the natural gas into a gathering pipeline as soon as the pipeline specifications are met.
 - 4) DJR provides the NMOCD with pipeline specifications and natural gas data.



DJR Operating LLC.
OGRID No: 371838

NATURAL GAS MANAGEMENT PLAN
North Alamito Unit 004H 301H 311H 312H

19.15.27.8 D. Venting and flaring during production operations

During Production Operations DJR will not vent or flare natural gas except under the following circumstances:

1. During an emergency or malfunction
2. To unload or clean-up liquid holdup in a well to atmospheric pressure, provided:
 - a. DJR does not vent after the well achieves a stabilized rate and pressure.
 - b. DJR will remain present on-site during liquids unloading by manual purging and tall all reasonable actions to achieve a stabilized rate and pressure at the earliest practical time.
 - c. DJR will optimize the system to minimize natural gas venting on any well equipped with a plunger lift or auto control system.
 - d. Best Management Practices will be used during downhole well maintenance.
3. During the first year of production from an exploratory well provided:
 - a. DJR receives approval from the NMOCD.
 - b. DJR remains in compliance with the NM gas capture requirements.
 - c. DJR submits an updated C-129 form to the NMOCD.
4. During the following activities unless prohibited:
 - a. Gauging or sampling a storage tank or low-pressure production vessel.
 - b. Loading out liquids from a storage tank.
 - c. Repair and maintenance.
 - d. Normal operation of gas activated pneumatic controller or pump.
 - e. Normal operation of a storage tank but not including venting from a thief hatch.
 - f. Normal operation of dehydration units.
 - g. Normal operations of compressors, compressor engines, turbines, valves, flanges, and connectors.
 - h. During a bradenhead, packer leakage test, or production test lasting less than 24-hours.
 - i. When natural gas does not meet the gathering pipeline specifications.
 - j. Commissioning of pipelines, equipment, or facilities only for as long as necessary to purge introduced impurities.

19.15.27.8 E. Performance standards

1. DJR has utilized process simulations with a safety factor to design all separation and storage equipment. The equipment is routed to a Vapor Recovery System and utilizes a flare as back up for periods of startup, shutdown, maintenance, or malfunction of the VRU System.
2. DJR will install a flare that designed to handle the full volume of vapors from the facility in case of the VRU failure and it its designed with an auto ignition system.
3. Flare stacks will appropriately sized and designed to ensure proper combustion efficiency.



DJR Operating LLC.

OGRID No: 371838

NATURAL GAS MANAGEMENT PLAN

North Alamito Unit 004H 301H 311H 312H

- a. Flare stacks installed or replaced will be equipped with an automatic ignitor or continuous pilot.
 - b. Previously installed flare stacks will be retrofitted with an automatic ignitor, continuous pilot, or technology that alerts DJR of flare malfunction within 18 months after May 25, 2021.
 - c. Flare stacks replaced after May 25, 2021, will be equipped with an automatic ignitor or continuous pilot if located at a well or facility with average daily production of 60,000 cubic feet of natural gas or less.
 - d. Flare stacks will be located at least 100 feet from the well and storage tanks and securely anchored.
4. DJR will conduct an AVO inspection on all components for leaks and defects on a weekly basis.
 5. DJR will make and keep records of AVO inspections which will be available to the NMOCD for at least 5 years.
 6. DJR may use a remote or automated monitoring technology to detect leaks and releases in lieu of AVO inspections with prior NMOCD approval.
 7. Facilities will be designed to minimize waste.
 8. DJR will resolve emergencies as promptly as possible.

19.15.27.8 F. Measurement or estimation of vented and flared natural gas

1. DJR will have meters on both the low- and high-pressure sides of the flares and the volumes will be recorded in DJR's SCADA system.
2. DJR will install equipment to measure the volume of flared natural gas that has an average daily production of 60,000 cubic feet or greater of natural gas.
3. DJR's measuring equipment will conform to the industry standards.
4. The measurement system is designed such that it cannot be bypassed except for inspections and servicing meters.
5. DJR will estimate the volume of vented or flared natural gas using a methodology that can be independently verified if metering is not practicable due to low flow rate or pressure.
6. DJR will estimate the volume of flared and vented natural gas based on the results of an annual GOR test for wells that do not require measuring equipment reported on Form C-116.
7. DJR will install measuring equipment whenever the NMOCD determines that metering is necessary.



DJR Operating LLC.
OGRID No: 371838
NATURAL GAS MANAGEMENT PLAN
North Alamito Unit 004H 301H 311H 312H

BEST MANAGEMENT PRACTICES

DJR utilizes the following Best Management Practices to minimize venting during active and planned maintenance.

DJR has a closed vent capture system to route emissions from the heater treater, tanks, and vapor recovery to the vapor recovery unit with an enclosed combustion device (ECD) for backup. The system is designed such that if the vapor recovery unit is taken out of service for any reason, the vapors will be routed to the ECD for combustion.

DJR will isolate and attempt to route all vapors to the vapor recovery unit or ECD prior to opening any lines for maintenance to minimize venting from the equipment.

DJR shall notify the NMOCD of venting or flaring that exceeds 50 MCF but less than 500 MCF in volume that either resulted from an emergency or malfunction, or an event lasting over eight hours or more cumulatively within any 24-hour period from a single event by filing a form C-129 no later than 15 days following the discovery or commencement of venting or flaring.

DJR shall notify the NMOCD verbally or by e-mail within 24-hours following discovery or commencement of venting or flaring that exceeds 500 MCF in volume or otherwise qualifies as a major release as defined in 19.15.29.7 NMAC from a single event and provide the information required in form C-129 to the NMOCD no later than 15 days that verifies, updates, or corrects the verbal or e-mail notification.

DJR will install measuring equipment to conform to industry standards such as American Petroleum Institute (API) Manual of Petroleum Measurement Standards (MPMS) Chapter 14.10 Measurement of Flow to Flares.

DJR's measuring equipment shall not be designed or equipped with a manifold that allows the diversion of natural gas around the metering element except for the sole purpose of inspecting and servicing the measurement equipment.

DJR shall report the volume of vented and flared natural gas for each well or facility at which venting or flaring occurred on a monthly basis.



ENDURING RESOURCES IV, LLC
6300 S SYRACUSE WAY, SUITE 525
CENTENNIAL, COLORADO 80211

DRILLING PLAN: *Drill, complete, and equip single lateral in the Mancos-H formation*

WELL INFORMATION:

Name: N Alamito Unit 311H

API Number: Not yet assigned

AFE Number: Not yet assigned

ER Well Number: Not yet assigned

State: New Mexico

County: San Juan

Surface Elevation: 6,946 ft ASL (GL) 6,970 ft ASL (KB)
Surface Location: 28-23-7 Sec-Twn-Rng 1,227 ft FSL 62 ft FEL
 36.193896 ° N latitude 107.571279 ° W longitude (NAD 83)
BH Location: 28-23-7 Sec-Twn-Rng 439 ft FNL 419 ft FWL
 36.204004 ° N latitude 107.587485 ° W longitude (NAD 83)

Driving Directions: FROM THE INTERSECTION OF US HWY 550 & US HWY 64 IN BLOOMFIELD, NM:

South on US Hwy 550 for 39.0 miles to MM 112.8; Right (South) on CR 7900/Indian Service Rte 7061 for 5.2 miles to fork (0.1 miles past T to Cty Rd 7950); Left (East) exiting CR 7900 for 5.6 miles to T; Left (North) for 1.2 miles to location NAU 232H pad. There are two existing wells on this pad; NAU 232H and 233H. There are four proposed new wells on this location, From West (location entrance) to East: N Alamito Unit 311H, 312H, 004H and 301H.

GEOLOGIC AND RESERVOIR INFORMATION:

<i>Prognosis:</i>	Formation Tops	TVD (ft ASL)	TVD (ft KB)	MD (ft KB)	O / G / W	Pressure
	Ojo Alamo	5,880	1,090	1,090	W	normal
	Kirtland	5,780	1,190	1,190	W	normal
	Fruitland	5,620	1,350	1,352	G, W	sub
	Pictured Cliffs	5,330	1,640	1,648	G, W	sub
	Lewis	5,170	1,800	1,812	G, W	normal
	Chacra	4,920	2,050	2,067	G, W	normal
	Cliff House	3,829	3,141	3,182	G, W	sub
	Menefee	3,789	3,181	3,222	G, W	normal
	Point Lookout	2,959	4,011	4,071	G, W	normal
	Mancos	2,744	4,226	4,290	O,G	sub (~0.38)
	Gallup (MNCS_A)	2,429	4,541	4,607	O,G	sub (~0.38)
	MNCS_B	2,334	4,636	4,702	O,G	sub (~0.38)
	MNCS_C	2,239	4,731	4,797	O,G	sub (~0.38)
	MNCS_Cms	2,199	4,771	4,837	O,G	sub (~0.38)
	MNCS_D	2,069	4,901	4,971	O,G	sub (~0.38)
	MNCS_E	1,949	5,021	5,104	O,G	sub (~0.38)
	MNCS_F	1,899	5,071	5,165	O,G	sub (~0.38)
	MNCS_G	1,820	5,150	5,276	O,G	sub (~0.38)
	MNCS_H	1,760	5,210	5,379	O,G	sub (~0.38)
	MNCS_I	1,700	5,270	5,535	O,G	sub (~0.38)
	FTP TARGET	1,820	5,150	5,276	O,G	sub (~0.38)

PROJECTED TD	1,696	5,274	11,509	O,G	sub (~0.38)
---------------------	--------------	--------------	---------------	------------	--------------------

Surface: Nacimiento

Oil & Gas Zones: Several gas bearing zones will be encountered; target formation is the Gallup

Pressure: Normal (0.43 psi/ft) or sub-normal pressure gradients anticipated in all formations

Max. pressure gradient: 0.43 psi/ft Evacuated hole gradient: 0.22 psi/ft

Maximum anticipated BH pressure, assuming maximum pressure gradient: 2,270 psi

Maximum anticipated surface pressure, assuming partially evacuated hole: 1,110 psi

Temperature: Maximum anticipated BHT is 125° F or less

H₂S INFORMATION:

H₂S Zones: Encountering hydrogen-sulfide bearing zones is **NOT** anticipated.

Safety: Sensors and alarms will be placed in the substructure, on the rig floor, above the pits, and at the shakers.

LOGGING, CORING, AND TESTING:

Mud Logs: None planned; remote geo-steering from drill out of 7" casing to TD; gas detection from drillout of 9-5/8" casing to TD.

MWD / LWD: Gamma Ray from drillout of 9-5/8" casing to TD

Open Hole Logs: None planned

Testing: None planned

Coring: None planned

Cased Hole Logs: CBL on 7" casing from deepest free-fall depth to surface

DRILLING RIG INFORMATION:

Contractor: Ensign

Rig No.: 140

Draw Works: Pacific Rim 1500AC (1,500 hp)

Mast: Process MFG Corp Swing Up Triple (136 ft, 750,000 lbs)

Top Drive: Tesco 400-EXI-600 (400 ton)

Prime Movers: 3 - CAT 3512C (1,350 hp)

Pumps: 2 - Gardner Denver PZ-11 (7,500 psi)

BOPE 1: T3 Annular & Shaffer double gate ram (11", 5,000 psi)

BOPE 2: T3 annular(11", 5,000 psi)

Choke 3", 5,000 psi

KB-GL (ft): 23.5

Note: Actual drilling rig may vary depending on availability at time the well is scheduled to be drilled.

BOPE REQUIREMENTS:

See attached diagram for details regarding BOPE specifications and configuration.

- 1) Rig will be equipped with upper and lower kelly cocks with handles available.
- 2) Inside BOP and TIW valves will be available to use on all sizes and threads of drill pipe used while drilling the well.
- 3) BOP accumulator will have enough capacity to open the HCR valve, close all rams and annular preventer, and retain minimum of 200 psi above precharge on the closing manifold without the use of closing pumps. The fluid reservoir capacity shall be at least double the usable fluid volume of the accumulator system capacity, and the fluid level shall be maintained at manufacturer's recommendation. There will be two additional sources of power for the closing pumps (electric and air). Sufficient nitrogen bottles will be available and will be recharged when pressure falls below manufacturer's recommended minimum.

4)

BOP testing shall be conducted (a) when initially installed, (b) whenever any seal is broken or repaired, (c) if the time since the previous test exceeds 30 days. Tests will be conducted using a test plug. BOP ram preventers will be tested to 3,000 psig for 10 minutes, and the annular preventer will be tested to 1,500 psi for 10 minutes. Ram and annular preventers will be tested to 250 psi for 5 minutes. Additionally, BOP and casing strings will be tested to .22 psi/ft or 1,500 psi, whichever is greater but not exceeding 70% of yield strength of the casing, for 30 minutes, prior to drilling out casing. Rams and hydraulically operated remote choke line valve will be function tested daily at a minimum.

- 5) Remote valve for BOP rams, HCR, and choke shall be placed in a location that is readily available to the driller. The remote BOP valve shall be capable of closing and opening the rams.
- 6) Manual locking devices (hand wheels) shall be installed on rams. A valve will be installed on the annular preventer's closing line as close as possible to the preventer to act as a locking device. The valve will be maintained in the open position and shall only be closed when there is no power to the accumulator.

FLUIDS AND SOLIDS CONTROL PROGRAM:

Fluid Measurement:

Pumps shall be equipped with stroke counters with displays in the dog-house. Slow pump speed shall be recorded daily and after mudding up, at a minimum, on the drilling report. A Pit Volume Totalizer will be installed and the readout will be displayed in the dog-house. Gas-detecting equipment will be installed at the shakers, and readouts will be available in the dog-house and the in the geologist's work-station (if geologist or mud-logger is on-site).

Closed-Loop System:

A fully, closed-loop system will be utilized. The system will consist of above-ground piping and above-ground storage tanks and bins. The system will not entail any earthen pits, below-grade storage, or drying pads. All equipment will be disassembled and removed from the site when drilling operations cease. The system will be capable of storing all fluids and generated cuttings and of preventing uncontrolled releases of the same. The system will be operated in an efficient manner to allow the recycling and reuse of as much fluid as possible and to minimize the amount of fluids and solids that require disposal.

Fluid Disposal: Fluids that cannot be reused, recycled, or returned to the supplier will be hauled to and disposed of at an approved disposal site (Industrial Ecosystem, Inc. or Envirotech, Inc.).

Solids Disposal: Drilling solids will be stored (until haul-off) on-site in separate containers with no other waste, debris, or garbage products. Waste solids will be hauled to and disposed of at an approved disposal site (Industrial Ecosystem, Inc. or Envirotech, Inc.).

Fluid Program: See "Detailed Drilling Plan" section and attached Newpark mud program for additional details.

DETAILED DRILLING PLAN:

SURFACE: *Drill vertically to casing setting depth (plus necessary rathole), run casing, cement casing to surface.*

0 ft (MD)	to	350 ft (MD)	Hole Section Length:	350 ft
0 ft (TVD)	to	350 ft (TVD)	Casing Required:	350 ft

Note: Surface hole may be drilled, cased, and cemented with a smaller rig in advance of the drilling rig.

Fluid:	Type	MW (ppg)	FL (mL/30 min)	PV (cp)	YP (lb/100 sqft)	pH	Comments
	Fresh Water	8.4	N/C	2 - 8	2 - 12	9.0	Spud mud

Hole Size: 12-1/4"

Bit / Motor: Mill Tooth or PDC, no motor

MWD / Survey: No MWD, deviation survey

Logging: None

Casing Specs:	Wt (lb/ft)	Grade	Conn.	Collapse (psi)	Burst (psi)	Tens. Body (lbs)	Tens. Conn (lbs)	
Specs	9.625	36.0	K-55	STC	2,020	3,520	564,000	423,000
Loading					153	1,130	110,988	110,988

Min. S.F.	13.21	3.11	5.08	3.81
-----------	-------	------	------	------

Assumptions: Collapse: fully evacuated casing with 8.4 ppg equivalent external pressure gradient
 Burst: maximum anticipated surface pressure with 9.5 ppg fluid inside casing while drilling intermediate hole and 8.4 ppg equivalent external pressure gradient
 Tension: buoyed weight in 8.4 ppg fluid with 100,000 lbs over-pull

MU Torque (ft lbs): Minimum: 3,400 Optimum: 4,530 Maximum: 5,660

Casing Summary: Float shoe, 1 jt casing, float collar, casing to surface

Centralizers: 2 centralizers per jt stop-banded 10' from each collar on bottom 3 jts, 1 centralizer per 2 jts to surface

Cement:	Type	Weight (ppg)	Yield (cuft/sk)	Water (gal/sk)	Hole Cap. (cuft/ft)	% Excess	Planned TOC (ft MD)	Total Cmt (sx)	Total Cmt (cu ft)
Redi-Mix	TYPE I-II	14.5	1.61	7.41	0.3132	50%	0	114	184

Calculated cement volumes assume gauge hole and the excess noted in table
 Mesa Ready Mix or first available
 Csg ID 8.921
 Shoe Track L 44

Notify NMOCD & BLM if cement is not circulated to surface. Cement must achieve 500 psi compressive strength before drilling out.

INTERMEDIATE: Drill as per directional plan to casing setting depth, run casing, cement casing to surface.

350 ft (MD)	to	5,632 ft (MD)	Hole Section Length:	5,282 ft
350 ft (TVD)	to	5,286 ft (TVD)	Casing Required:	5,632 ft

Fluid:	Type	MW (ppg)	FL (mL/30 min)	PV (cp)	YP (lb/100 sqft)	pH	Comments
	LSND (KCl)	8.8 - 9.2	15	8 - 14	6 - 12	10.8 - 11.2	No OBM

Hole Size (inches): 8.75

Bit / Motor: 8-3/4" PDC bit w/mud motor

MWD / Survey: MWD Survey with inclination and azimuth survey (every 100' at a minimum), GR optional

Logging: None

Pressure Test: NU BOPE and test (as noted above); pressure test 9-5/8" casing to 1,500 psi for 30 minutes.

Casing Specs:	Wt (lb/ft)	Grade	Conn.	Collapse (psi)	Burst (psi)	Tens. Body (lbs)	Tens. Conn (lbs)
Specs	7	26.0	K-55	LTC	4,320	4,980	415,000
Loading					2,309	1,412	227,696
Min. S.F.					1.87	3.53	1.82

Assumptions: Collapse: fully evacuated casing with 8.4 ppg equivalent external pressure gradient
 Burst: maximum anticipated surface pressure with 9.5 ppg fluid inside casing while drilling production hole and 8.4 ppg equivalent external pressure gradient
 Tension: buoyed weight in 8.4 ppg fluid with 100,000 lbs over-pull

MU Torque (ft lbs): Minimum: 3,400 Optimum: 4,530 Maximum: 5,660

Centralizers: 1 per joint in non-vertical hole; 1 per 2-joints in vertical hole

Cement:	Type	Weight (ppg)	Yield (cuft/sk)	Water (gal/sk)	% Excess	Planned TOC (ft MD)	Total Cmt (sx)	Total Cmt (cu ft)
Lead	III:POZ Blend	12.5	2.150	12.05	70%	0	484	1,040
Tail	Type III	13.5	1.710	8.88	30%	4,190	170	291
Annular Capacity	0.16681	cuft/ft	7" casing x 9-5/8" casing annulus				Shoe Track L	44
	0.1503	cuft/ft	7" casing x 8-3/4" hole annulus				Casing ID	6.276
	0.2148	cuft/ft	7" casing casing volume				Est displacement bbls	213.8

Calculated cement volumes assume gauge hole and the excess noted in table

10 bbls D-Mud
 Breaker (SAPP)

Spacer 10 bbls water f/b f/b 10 bbls water f/b

		D-CSE 1 5.0%	D-MPA-2 .4%					
		BWOC Fluid Loss & D-SA 1 1.4%						
Lead	ASTM Type III 90/10 Poz	BWOC Strength Enhancer	Gas Migration Control	BWOC Na Metasilicate	D-CD 2 .4%	Cello Flace LCM .25 lb/sx	D-FP 1 .5%	D-R1 1.2%
					BWOC Dispersant		BWOC Defoamer	Retarder
		D-CSE 1 5.0%	D-MPA-2 1.2%					
		BWOC Fluid Loss &						
Tail	ASTM Type III 90/10 Poz	BWOC Strength Enhancer	Gas Migration Control	Cello Flace LCM .25 lb/sx	D-FP 1 .5%	D-R1 0.3%		
					BWOC Defoamer	Retarder		

Drake Intermediate Cementing Program

Notify NMOCD & BLM if cement is not circulated to surface. Cement must achieve 500 psi compressive strength before drilling out.

PRODUCTION: Drill to TD following directional plan, run casing, cement casing to surface.

5,632 ft (MD)	to	11,509 ft (MD)	Hole Section Length:	5,877 ft
5,286 ft (TVD)	to	5,274 ft (TVD)	Casing Required:	6,027 ft
Estimated KOP:		4,782 ft (MD)	4,716 ft (TVD)	
Estimated Liner Top:		5,482 ft (MD)	5,254 ft (TVD)	
Estimated Landing Point (FTP):		5,276 ft (MD)	5,150 ft (TVD)	
Estimated Lateral Length:		6,233 ft (MD)		

Fluid:	Type	MW (ppg)	FL (mL/30')	PV (cp)	YP (lb/100 sqft)	pH	Comments	Comments
	WBM	8.7 - 9.0	NC	+20	±2	9-9.5	prod water	OBM as contingency

Hole Size: 6.125

Bit / Motor: 6-1/8" PDC bit w/mud motor

MWD / Survey: MWD with GR, inclination, and azimuth (survey every joint from KOP to Landing Point and survey every 100' minimum before KOP and after Landing Point)

Logging: GR MWD for entire section, no mud-log or cuttings sampling, no OH WL logs

Pressure Test: NU BOPE and test (as noted above); pressure test 9-5/8" casing to **1,500** psi for 30 minutes.

Liner/Casing Specs:	Size (in)	Wt (lb/ft)	Grade	Conn.	Collapse (psi)	Burst (psi)	Tens. Body (lbs)	Tens. Conn (lbs)
Specs	4.500	11.6	P-110	BTC	7,560	10,690	367,000	385,000
Loading					2,605	8,802	215,202	215,202
Min. S.F.					2.90	1.21	1.71	1.79

Assumptions: Collapse: fully evacuated casing with 9.5 ppg fluid in the annulus (floating casing during running)

Burst: 8,500 psi maximum surface treating pressure with 10.2 ppg equivalent mud weight sand laden fluid with 8.4 ppg equivalent external pressure gradient.

Tension: buoyed weight in 9.0 ppg fluid with 100,000 lbs over-pull. Tension calculations assume vertical hole to approximate drag in lateral.

MU Torque (ft lbs): Minimum: BTC Optimum: BTC Maximum: BTC

Centralizers: Centralizer count and placement may be adjusted based on well conditions and as-drilled surveys.

Cement:	Type	Weight (ppg)	Yield (cuft/sk)	Water (gal/sk)	% Excess	Planned TOC (ft MD)	Total Cmt (sx)	Total Cmt (cu ft)
Spacer	Water	8.4				0	10 bbls	
Spacer	IntegraGuard Star	10		35.7		0	20 bbls	
Tail	G:POZ blend	13.3	1.520	7.50	25%	5,482	468	711

Displacement 149 est bbls

Annular Capacities	0.1044	cuft/ft	4-1/2" casing x 7" casing annulus	
	0.09417	cuft/ft	4-1/2" casing x 6-1/8" hole annulus	
	0.0873	cuft/ft	4-1/2" casing volume	est shoe jt ft 42
	0.0102	bbls/ft	4" DP capacity	

Calculated cement volumes assume gauge hole and the excess noted in table
 American Cementing Liner & Production Blend

Spacer	S-8 Silica Flour 113.2 lbs/bbl	Avis 616 viscosifier 4.0 lb/bbl	Xcem-311 Defoamer .8 lb/bbl	SS201 Surfactant 0.5 gal/bbl				
Lead/Tail	Type G 50%	Pozzolan Fly Ash Extender 50%	Bentonite Viscosifier 4% BWOB	FL24 Fluid Loss .4% BWOB	IntegraGuard GW86 Viscosifier .1% BWOB	R3 Retarder .2% BWOB	Xcem-311 Defoamer 0.3% BWOB	

Notify NMOCD & BLM if cement is not circulated to surface.

Note: This well will not be considered an unorthodox well location as defined by NMAC19.15.16.15.C.5. As defined in NMAC 19.15.16.15.C.1.a and 19.15.16.15.C.1.b, no point in the completed interval shall be closer to the unit boundary than 100' measured along the azimuth of the well or 330' measured perpendicular to the azimuth well. The boundaries of the completed interval, as defined by NMAC 19.15.16.7.B, are the last take point and first take point, as defined by NMAC 19.15.16.7.E and NMAC 19.15.16.7.J, respectively. In the case of this well, the last take point will be the bottom toe-initiation sleeve, and the first take point will be the top perforation. **Neither the toe-initiation sleeve nor the top perforation shall be closer to the unit boundary than 100' measured along the azimuth of the well or 330' measured perpendicular to the azimuth of the well.**

FINISH WELL: ND BOP, cap well, RDMO.

COMPLETION AND PRODUCTION PLAN:

Est Lateral Length: 6,133
Est Frac Inform: 26 Frac Stages 99,000 bbls slick water 7,980,000 lbs proppant
Frac: 39 plug-and-perf stages with 150,000 bbls slickwater fluid and 12,100,000 lbs of proppant (estimated)
Flowback: Flow back through production tubing as pressures allow
Production: Produce through production tubing via gas-lift into permanent production and storage facilities

ESTIMATED START DATES:

Drilling: 12/16/2025
Completion: 2/14/2026
Production: 3/31/2026

Prepared by: Greg Olson 7/18/2024
Updated: Greg Olson 5/1/2025

WELL NAME: N Alamito Unit 311H

OBJECTIVE: Drill, complete, and equip single lateral in the Mancos-H formation

API Number: Not yet assigned

AFE Number: Not yet assigned

ER Well Number: Not yet assigned

State: New Mexico

County: San Juan

Surface Elev.: 6,946 ft ASL (GL) 6,970 ft ASL (KB)

Surface Location: 28-23-7 Sec-Twn- Rng 1,227 ft FSL 62 ft FEL

BH Location: 28-23-7 Sec-Twn- Rng 439 ft FNL 419 ft FWL

Driving Directions: FROM THE INTERSECTION OF US HWY 550 & US HWY 64 IN BLOOMFIELD, NM:

South on US Hwy 550 for 39.0 miles to MM 112.8; Right (South) on CR 7900/Indian Service Rte 7061 for 5.2 miles to fork (0.1 miles past T to Cty Rd 7950); Left (East) exiting CR 7900 for 5.6 miles to T; Left (North) for 1.2 miles to location NAU 232H pad. There are two existing wells on this pad; NAU 232H and 233H. There are four proposed new wells on this location, From West (location entrance) to East: N Alamito Unit 311H, 312H, 004H and 301H.

QUICK REFERENCE	
Sur TD (MD)	350 ft
Int TD (MD)	5,632 ft
KOP (MD)	4,782 ft
KOP (TVD)	4,716 ft
Target (TVD)	5,150 ft
Curve BUR	10 °/100 ft
POE (MD)	5,276 ft
TD (MD)	11,509 ft
Lat Len (ft)	6,233 ft

WELL CONSTRUCTION SUMMARY:

	Hole (in)	TD MD (ft)	Csg (in)	Csg (lb/ft)	Csg (grade)	Csg (conn)	Csg Top (ft)	Csg Bot (ft)
Surface	12.250	350	9.625	36	K-55	STC	0	350
Intermediate	8.750	5,632	7	26.0	K-55	LTC	0	5,632
Production	6.125	11,509	4.500	11.6	P-110	BTC	5,482	11,509

CEMENT PROPERTIES SUMMARY:

	Type	Wt (ppg)	Yd (cuft/sk)	Wtr (gal/sk)	Hole Cap. (cuft/ft)	% Excess	TOC (ft MD)	Total (sx)
Surface	TYPE I-II	14.5	1.61	7.41	0.3132	50%	0	114
Inter. (Lead)	III:POZ Blend	12.5	2.15	12.05	0.1668	70%	0	484
	Type III	13.5	1.71	8.88	0.1503	30%	4,190	170
Prod. (Lead)	tegraGuard S	10	0.000	35.7	0.1044	0%	0	20 bbls
Prod. (Tail)	G:POZ blend	13.3	1.520	7.5	0.0873	25%	5,482	468

COMPLETION / PRODUCTION SUMMARY:

Frac: 39 plug-and-perf stages with 150,000 bbls slickwater fluid and 12,100,000 lbs of proppant (estimated)

Flowback: Flow back through production tubing as pressures allow

Production: Produce through production tubing via gas-lift into permanent production and storage facilities

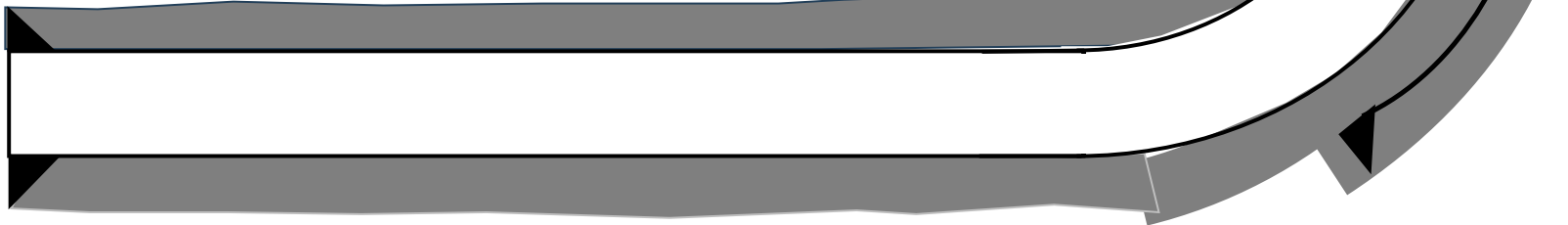

Tops	TVD (ft KB)	MD (ft KB)
Ojo Alamo	1,090	1,090
Kirtland	1,190	1,190
Fruitland	1,350	1,352
Pictured Cliffs	1,640	1,648
Lewis	1,800	1,812
Chacra	2,050	2,067
Cliff House	3,141	3,182
Menefee	3,181	3,222
Point Lookout	4,011	4,071
Mancos	4,226	4,290
Gallup (MNCS_A)	4,541	4,607
MNCS_B	4,636	4,702
MNCS_C	4,731	4,797
MNCS_Cms	4,771	4,837
MNCS_D	4,901	4,971
MNCS_E	5,021	5,104
MNCS_F	5,071	5,165
MNCS_G	5,150	5,276
MNCS_H	5,210	5,379
MNCS_I	5,270	5,535
FTP TARGET	5,150	5,276
PROJECTED TD	5,274	11,509

N ALAMITO UNIT 311H

NOTE: EXACT BOPE AND CHOKE CONFIGURATION AND COMPONENTS MAY DIFFER FROM WHAT IS DEPICTED IN THE DIGRAMS BELOW DEPENDING ON THE RIG AND ITS ASSOCIATED EQUIPMENT. RAM PREVENTERS, ANNULAR PREVENTERS, AND CHOKE MANIFOLD AND COMPONENTS WILL BE RATED TO 3,000 PSI MINIMUM.

CHOKE MANIFOLD

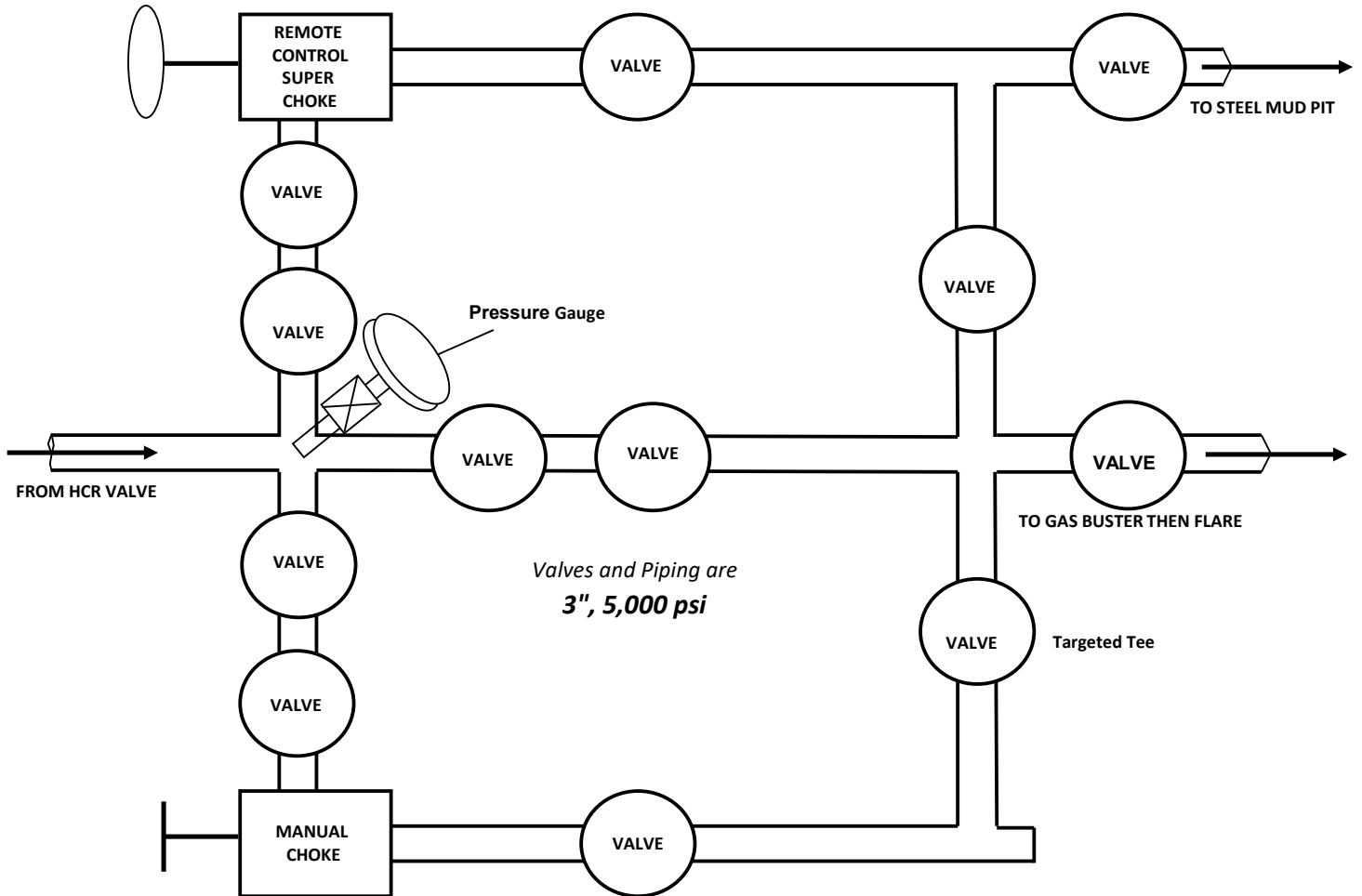

N ALAMITO UNIT 311H

NOTE: EXACT BOPE AND CHOKE CONFIGURATION AND COMPONENTS MAY DIFFER FROM WHAT IS DEPICTED IN THE DIGRAMS BELOW DEPENDING ON THE RIG AND ITS ASSOCIATED EQUIPMENT. RAM PREVENTERS, ANNULAR PREVENTERS, AND CHOKE MANIFOLD AND COMPONENTS WILL BE RATED TO 3,000 PSI MINIMUM.

BOPE

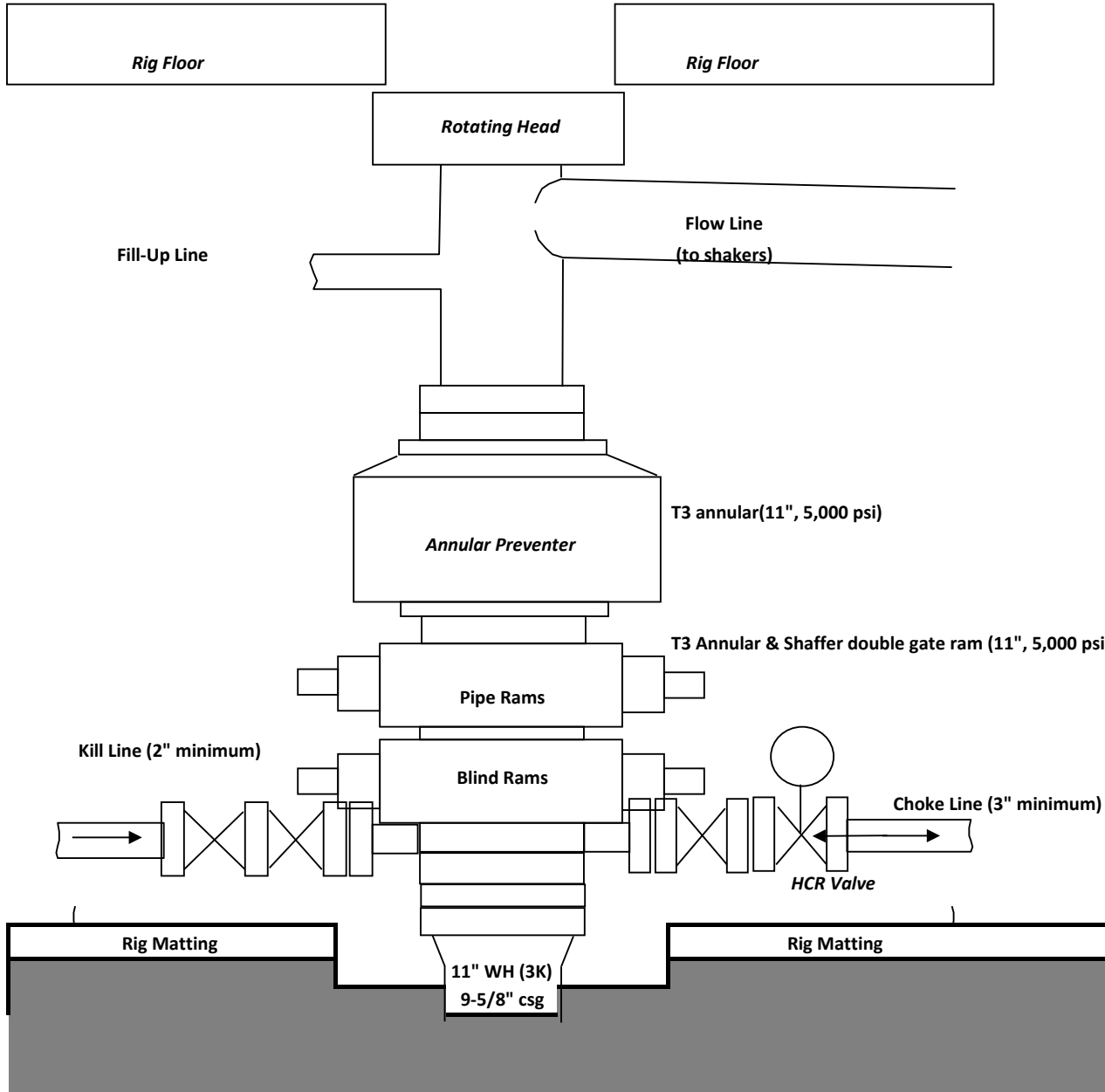



Anticollision Report

Company:	Enduring Resources LLC	Local Co-ordinate Reference:	Well North Alamito Unit 311H
Project:	Sandoval County, New Mexico NAD83 NM C	TVD Reference:	RKB=6946+23.5 @ 6969.50ft
Reference Site:	Sec 28 T23N R07W North Alamito 4 301 311&312	MD Reference:	RKB=6946+23.5 @ 6969.50ft
Site Error:	0.00 ft	North Reference:	Grid
Reference Well:	North Alamito Unit 311H	Survey Calculation Method:	Minimum Curvature
Well Error:	0.00 ft	Output errors are at	2.00 sigma
Reference Wellbore	Original Hole	Database:	DT-Oct0825v17
Reference Design:	rev1	Offset TVD Reference:	Offset Datum

Reference	rev1		
Filter type:	GLOBAL FILTER APPLIED: All wellpaths within 200'+ 100/1000 of reference		
Interpolation Method:	MD Interval 100.00ft	Error Model:	ISCWSA
Depth Range:	Unlimited	Scan Method:	Closest Approach 3D
Results Limited by:	Maximum centre distance of 1,347.60ft	Error Surface:	Ellipsoid Separation
Warning Levels Evaluated at:	2.00 Sigma	Casing Method:	Not applied

Survey Tool Program	Date	12/10/2025		
From (ft)	To (ft)	Survey (Wellbore)	Tool Name	Description
0.00	11,475.53	rev1 (Original Hole)	MWD	OWSG MWD - Standard

Summary							
Site Name	Reference Measured Depth (ft)	Offset Measured Depth (ft)	Distance Between Centres (ft)	Distance Between Ellipses (ft)	Separation Factor	Warning	
Offset Well - Wellbore - Design							
North Alamito Unit (05 & 06)							
North Alamito Unit 006 H - Original Hole - MWD surveys	11,476.02	14,030.00	569.35	258.39	1.831	Level 3<2.00, CC, ES, SF	
Sec 19 T23N R07W BetonnieTosieWash101,103,105&107							
North Alamito Unit 102 H - Original Hole - MWD surveys	11,476.02	15,067.00	650.54	300.13	1.857	Level 3<2.00, CC, ES, SF	
Sec 28 T23N R07W North Alamito 4 301 311&312							
North Alamito Unit 004H - Original Hole - rev1	600.00	600.00	39.85	35.71	9.641	CC, ES	
North Alamito Unit 004H - Original Hole - rev1	800.00	796.92	46.57	41.02	8.397	SF	
North Alamito Unit 232H - Orig Hole - MWD surveys	100.00	89.34	121.54	121.12	283.707	CC	
North Alamito Unit 232H - Orig Hole - MWD surveys	800.00	789.02	123.17	118.29	25.208	ES	
North Alamito Unit 232H - Orig Hole - MWD surveys	11,476.02	11,350.00	1,273.39	987.94	4.461	SF	
North Alamito Unit 233H - Orig Hole - MWD surveys	100.00	89.27	92.30	91.87	215.495	CC	
North Alamito Unit 233H - Orig Hole - MWD surveys	600.00	589.07	95.21	91.73	27.367	ES	
North Alamito Unit 233H - Orig Hole - MWD surveys	1,000.00	980.05	108.45	102.14	17.198	SF	
North Alamito Unit 301H - Original Hole - rev1	800.00	800.00	59.92	54.35	10.763	CC, ES	
North Alamito Unit 301H - Original Hole - rev1	1,000.00	997.35	63.92	56.94	9.151	SF	
North Alamito Unit 312H - Original Hole - rev1	1,000.00	1,000.00	19.78	12.77	2.825	CC, ES	
North Alamito Unit 312H - Original Hole - rev1	1,100.00	1,099.95	20.48	12.78	2.660	SF	

Offset Design:	North Alamito Unit (05 & 06) - North Alamito Unit 006 H - Original Hole - MWD surveys											Offset Site Error:	0.00 ft	
Survey Program:	396-MWD, 6327-MWD, 14030-MWD											Offset Well Error:	0.00 ft	
Measured Depth (ft)	Vertical Depth (ft)	Measured Depth (ft)	Vertical Depth (ft)	Reference (ft)	Offset (ft)	Semi Major Axis (ft)	Highside Toolface (°)	Offset Wellbore Centre		Distance		Minimum Separation (ft)	Separation Factor	Warning
								+N/-S (ft)	+E/-W (ft)	Between Centres (ft)	Between Ellipses (ft)			
10,400.00	5,276.63	14,030.00	5,357.93	119.78	174.60	90.526	90.526	4,217.87	-4,413.70	1,298.00	1,176.78	121.22	10.708	
10,500.00	5,276.39	14,030.00	5,357.93	122.08	174.60	90.526	90.526	4,217.87	-4,413.70	1,208.62	1,080.27	128.35	9.417	
10,600.00	5,276.14	14,030.00	5,357.93	124.37	174.60	90.526	90.526	4,217.87	-4,413.70	1,121.03	984.30	136.73	8.199	
10,700.00	5,275.90	14,030.00	5,357.93	126.67	174.60	90.526	90.526	4,217.87	-4,413.70	1,035.69	889.01	146.68	7.061	
10,800.00	5,275.65	14,030.00	5,357.93	128.96	174.60	90.526	90.526	4,217.87	-4,413.70	953.20	794.63	158.57	6.011	
10,900.00	5,275.41	14,030.00	5,357.93	131.26	174.60	90.526	90.526	4,217.87	-4,413.70	874.38	701.50	172.88	5.058	
11,000.00	5,275.16	14,030.00	5,357.93	133.56	174.60	90.526	90.526	4,217.87	-4,413.70	800.30	610.12	190.18	4.208	
11,100.00	5,274.92	14,030.00	5,357.93	135.86	174.60	90.526	90.526	4,217.87	-4,413.70	732.41	521.38	211.03	3.471	
11,200.00	5,274.67	14,030.00	5,357.93	138.16	174.60	90.526	90.526	4,217.87	-4,413.70	672.59	436.78	235.81	2.852	
11,300.00	5,274.43	14,030.00	5,357.93	140.46	174.60	90.526	90.526	4,217.87	-4,413.70	623.15	359.14	264.01	2.360	

CC - Min centre to center distance or convergent point, SF - min separation factor, ES - min ellipse separation



Anticollision Report

Company:	Enduring Resources LLC	Local Co-ordinate Reference:	Well North Alamito Unit 311H
Project:	Sandoval County, New Mexico NAD83 NM C	TVD Reference:	RKB=6946+23.5 @ 6969.50ft
Reference Site:	Sec 28 T23N R07W North Alamito 4 301 311&312	MD Reference:	RKB=6946+23.5 @ 6969.50ft
Site Error:	0.00 ft	North Reference:	Grid
Reference Well:	North Alamito Unit 311H	Survey Calculation Method:	Minimum Curvature
Well Error:	0.00 ft	Output errors are at	2.00 sigma
Reference Wellbore	Original Hole	Database:	DT-Oct0825v17
Reference Design:	rev1	Offset TVD Reference:	Offset Datum

Offset Design:	North Alamito Unit (05 & 06) - North Alamito Unit 006 H - Original Hole - MWD surveys											Offset Site Error:	0.00 ft
Survey Program:	396-MWD, 6327-MWD, 14030-MWD											Offset Well Error:	0.00 ft
Reference	Rule Assigned:											Warning	
Measured Depth (ft)	Vertical Depth (ft)	Measured Depth (ft)	Vertical Depth (ft)	Semi Major Axis Reference (ft)	Semi Major Axis Offset (ft)	Highside Toolface (°)	Offset Wellbore Centre		Distance		Minimum Separation (ft)	Separation Factor	
							+N/-S (ft)	+E/-W (ft)	Between Centres (ft)	Between Ellipses (ft)			
11,400.00	5,274.19	14,030.00	5,357.93	142.76	174.60	90.526	4,217.87	-4,413.70	586.74	293.89	292.85	2.004	
11,476.02	5,274.00	14,030.00	5,357.93	144.51	174.60	90.526	4,217.87	-4,413.70	569.35	258.39	310.96	1.831	Level 3<2.00, CC, ES, SF



Anticollision Report

Company:	Enduring Resources LLC	Local Co-ordinate Reference:	Well North Alamito Unit 311H
Project:	Sandoval County, New Mexico NAD83 NM C	TVD Reference:	RKB=6946+23.5 @ 6969.50ft
Reference Site:	Sec 28 T23N R07W North Alamito 4 301 311&312	MD Reference:	RKB=6946+23.5 @ 6969.50ft
Site Error:	0.00 ft	North Reference:	Grid
Reference Well:	North Alamito Unit 311H	Survey Calculation Method:	Minimum Curvature
Well Error:	0.00 ft	Output errors are at	2.00 sigma
Reference Wellbore	Original Hole	Database:	DT-Oct0825v17
Reference Design:	rev1	Offset TVD Reference:	Offset Datum

Offset Design: Sec 19 T23N R07W BetonnieTsoieWash101,103,105&107 - North Alamito Unit 102 H - Original Hole - MWD surveys												Offset Site Error:	0.00 ft
Survey Program: 485-MWD, 5839-MWD, 14987-MWD												Offset Well Error:	0.00 ft
Measured Depth (ft)	Vertical Depth (ft)	Offset		Semi Major Axis		Highside Toolface (°)	Offset Wellbore Centre		Distance		Minimum Separation (ft)	Separation Factor	Warning
		Measured Depth (ft)	Vertical Depth (ft)	Reference (ft)	Offset (ft)		+N/-S (ft)	+E/-W (ft)	Between Centres (ft)	Between Ellipses (ft)			
10,400.00	5,276.63	15,067.00	5,278.04	119.78	209.19	-88.953	3,297.67	-5,203.29	1,286.07	1,156.90	129.17	9.956	
10,500.00	5,276.39	15,067.00	5,278.04	122.08	209.19	-88.953	3,297.67	-5,203.29	1,200.83	1,061.50	139.33	8.619	
10,600.00	5,276.14	15,067.00	5,278.04	124.37	209.19	-88.953	3,297.67	-5,203.29	1,118.03	966.84	151.20	7.395	
10,700.00	5,275.90	15,067.00	5,278.04	126.67	209.19	-88.953	3,297.67	-5,203.29	1,038.28	873.15	165.12	6.288	
10,800.00	5,275.65	15,067.00	5,278.04	128.96	209.19	-88.953	3,297.67	-5,203.29	962.31	780.78	181.52	5.301	
10,900.00	5,275.41	15,067.00	5,278.04	131.26	209.19	-88.953	3,297.67	-5,203.29	891.09	690.24	200.85	4.437	
11,000.00	5,275.16	15,067.00	5,278.04	133.56	209.19	-88.953	3,297.67	-5,203.29	825.87	602.35	223.52	3.695	
11,100.00	5,274.92	15,067.00	5,278.04	135.86	209.19	-88.953	3,297.67	-5,203.29	768.17	518.44	249.73	3.076	
11,200.00	5,274.67	15,067.00	5,278.04	138.16	209.19	-88.953	3,297.67	-5,203.29	719.79	440.77	279.02	2.580	
11,300.00	5,274.43	15,067.00	5,278.04	140.46	209.19	-88.953	3,297.67	-5,203.29	682.73	373.26	309.46	2.206	
11,400.00	5,274.19	15,067.00	5,278.04	142.76	209.19	-88.953	3,297.67	-5,203.29	658.89	322.36	336.52	1.958	Level 3<2.00
11,476.02	5,274.00	15,067.00	5,278.04	144.51	209.19	-88.953	3,297.67	-5,203.29	650.54	300.13	350.41	1.857	Level 3<2.00, CC, ES, SF

CC - Min centre to center distance or convergent point, SF - min separation factor, ES - min ellipse separation



Anticollision Report

Company:	Enduring Resources LLC	Local Co-ordinate Reference:	Well North Alamito Unit 311H
Project:	Sandoval County, New Mexico NAD83 NM C	TVD Reference:	RKB=6946+23.5 @ 6969.50ft
Reference Site:	Sec 28 T23N R07W North Alamito 4 301 311&312	MD Reference:	RKB=6946+23.5 @ 6969.50ft
Site Error:	0.00 ft	North Reference:	Grid
Reference Well:	North Alamito Unit 311H	Survey Calculation Method:	Minimum Curvature
Well Error:	0.00 ft	Output errors are at	2.00 sigma
Reference Wellbore	Original Hole	Database:	DT-Oct0825v17
Reference Design:	rev1	Offset TVD Reference:	Offset Datum

Offset Design: Sec 28 T23N R07W North Alamito 4 301 311&312 - North Alamito Unit 004H - Original Hole - rev1													Offset Site Error:	0.00 ft
Survey Program: 0-MWD													Offset Well Error:	0.00 ft
Measured Depth (ft)	Vertical Reference Depth (ft)	Offset		Semi Major Axis		Highside Toolface (°)	Offset Wellbore Centre		Distance		Minimum Separation (ft)	Separation Factor	Warning	
		Measured Depth (ft)	Vertical Depth (ft)	Reference (ft)	Offset (ft)		+N/-S (ft)	+E/-W (ft)	Between Centres (ft)	Between Ellipses (ft)				
0.00	0.00	0.00	0.00	0.00	0.00	89.733	0.19	39.85	39.85					
100.00	100.00	100.00	100.00	0.27	0.27	89.733	0.19	39.85	39.85	39.30	0.55	72.651		
200.00	200.00	200.00	200.00	0.63	0.63	89.733	0.19	39.85	39.85	38.58	1.27	31.489		
300.00	300.00	300.00	300.00	0.99	0.99	89.733	0.19	39.85	39.85	37.86	1.98	20.101		
400.00	400.00	400.00	400.00	1.35	1.35	89.733	0.19	39.85	39.85	37.15	2.70	14.762		
500.00	500.00	500.00	500.00	1.71	1.71	89.733	0.19	39.85	39.85	36.43	3.42	11.664		
600.00	600.00	600.00	600.00	2.07	2.07	89.733	0.19	39.85	39.85	35.71	4.13	9.641	CC, ES	
700.00	700.00	698.72	698.68	2.43	2.42	86.847	2.28	41.31	41.39	36.55	4.84	8.547		
800.00	800.00	796.92	796.57	2.78	2.78	79.459	8.50	45.66	46.57	41.02	5.55	8.397	SF	
900.00	900.00	894.08	892.92	3.14	3.13	70.497	18.70	52.80	56.46	50.22	6.24	9.054		
1,000.00	1,000.00	989.74	987.04	3.50	3.50	62.438	32.66	62.56	71.75	64.85	6.90	10.393		
1,100.00	1,099.95	1,082.84	1,077.71	3.84	3.90	-136.132	49.93	74.65	94.35	86.82	7.53	12.530		
1,200.00	1,199.63	1,171.84	1,163.34	4.17	4.31	-141.925	69.81	88.56	126.29	118.18	8.12	15.556		
1,300.00	1,298.77	1,255.77	1,242.96	4.51	4.73	-146.198	91.53	103.76	167.39	158.72	8.67	19.307		
1,400.00	1,397.08	1,333.89	1,315.96	4.87	5.16	-149.160	114.30	119.69	217.00	207.80	9.20	23.582		
1,500.00	1,494.89	1,406.97	1,383.17	5.26	5.59	-151.895	137.81	136.14	272.54	262.85	9.69	28.122		
1,600.00	1,592.69	1,476.30	1,445.88	5.66	6.05	-153.717	162.04	153.09	331.48	321.33	10.15	32.662		
1,700.00	1,690.49	1,541.99	1,504.26	6.08	6.51	-154.983	186.70	170.35	393.43	382.84	10.59	37.168		
1,800.00	1,788.30	1,600.00	1,554.93	6.51	6.93	-155.839	209.84	186.53	458.10	447.16	10.94	41.869		
1,900.00	1,886.10	1,663.01	1,608.97	6.95	7.44	-156.566	236.38	205.11	525.17	513.78	11.40	46.081		
2,000.00	1,983.90	1,719.53	1,656.51	7.39	7.90	-157.082	261.42	222.63	594.50	582.72	11.78	50.453		
2,100.00	2,081.71	1,790.54	1,715.74	7.84	8.52	-157.602	293.52	245.08	664.79	652.41	12.38	53.697		
2,200.00	2,179.51	1,861.55	1,774.98	8.30	9.15	-158.023	325.61	267.54	735.10	722.11	12.99	56.603		
2,300.00	2,277.31	1,932.57	1,834.21	8.76	9.79	-158.370	357.70	289.99	805.42	791.82	13.60	59.224		
2,400.00	2,375.12	2,003.58	1,893.45	9.23	10.43	-158.662	389.80	312.45	875.76	861.54	14.22	61.594		
2,500.00	2,472.92	2,074.60	1,952.68	9.70	11.09	-158.910	421.89	334.90	946.11	931.27	14.84	63.735		
2,600.00	2,570.72	2,145.61	2,011.92	10.17	11.75	-159.124	453.99	357.36	1,016.47	1,000.99	15.47	65.685		
2,700.00	2,668.53	2,216.63	2,071.15	10.65	12.42	-159.311	486.08	379.81	1,086.83	1,070.72	16.11	67.468		
2,800.00	2,766.33	2,287.64	2,130.39	11.12	13.09	-159.474	518.17	402.27	1,157.20	1,140.45	16.75	69.098		
2,900.00	2,864.13	2,358.66	2,189.62	11.60	13.76	-159.619	550.27	424.72	1,227.57	1,210.18	17.39	70.593		
3,000.00	2,961.94	2,429.67	2,248.86	12.08	14.44	-159.749	582.36	447.18	1,297.95	1,279.91	18.03	71.969		

CC - Min centre to center distance or convergent point, SF - min separation factor, ES - min ellipse separation



Anticollision Report

Company:	Enduring Resources LLC	Local Co-ordinate Reference:	Well North Alamito Unit 311H
Project:	Sandoval County, New Mexico NAD83 NM C	TVD Reference:	RKB=6946+23.5 @ 6969.50ft
Reference Site:	Sec 28 T23N R07W North Alamito 4 301 311&312	MD Reference:	RKB=6946+23.5 @ 6969.50ft
Site Error:	0.00 ft	North Reference:	Grid
Reference Well:	North Alamito Unit 311H	Survey Calculation Method:	Minimum Curvature
Well Error:	0.00 ft	Output errors are at	2.00 sigma
Reference Wellbore	Original Hole	Database:	DT-Oct0825v17
Reference Design:	rev1	Offset TVD Reference:	Offset Datum

Offset Design: Sec 28 T23N R07W North Alamito 4 301 311&312 - North Alamito Unit 232H - Orig Hole - MWD surveys													Offset Site Error:	0.00 ft
Survey Program: 365-MWD													Offset Well Error:	0.00 ft
Rule Assigned:														
Measured Depth (ft)	Reference Vertical Depth (ft)	Offset Measured Depth (ft)	Offset Vertical Depth (ft)	Semi Major Axis Reference (ft)	Semi Major Axis Offset (ft)	Highside Toolface (°)	Offset Wellbore Centre		Distance		Minimum Separation (ft)	Separation Factor	Warning	
							+N/-S (ft)	+E/-W (ft)	Between Centres (ft)	Between Ellipses (ft)				
0.00	0.00	0.00	0.00	0.00	0.00	9.302	119.89	19.64	121.94					
100.00	100.00	89.34	89.34	0.27	0.15	9.254	119.96	19.55	121.54	121.12	0.43	283.707	CC	
200.00	200.00	189.17	189.17	0.63	0.33	9.088	120.22	19.23	121.74	120.79	0.96	126.932		
300.00	300.00	288.99	288.99	0.99	0.50	8.804	120.65	18.69	122.09	120.60	1.49	81.950		
400.00	400.00	389.09	389.09	1.35	0.72	8.422	121.24	17.95	122.56	120.50	2.07	59.333		
500.00	500.00	489.75	489.74	1.71	1.07	8.568	121.20	18.26	122.57	119.80	2.77	44.189		
587.34	587.34	576.88	576.84	2.02	1.36	9.546	120.80	20.31	122.49	119.11	3.38	36.235		
600.00	600.00	589.52	589.47	2.07	1.40	9.725	120.73	20.69	122.49	119.03	3.47	35.309		
700.00	700.00	689.09	688.97	2.43	1.75	11.524	120.27	24.52	122.74	118.57	4.17	29.406		
800.00	800.00	789.02	788.81	2.78	2.10	13.588	119.72	28.94	123.17	118.29	4.89	25.208	ES	
900.00	900.00	888.15	887.80	3.14	2.46	15.923	119.19	34.00	123.96	118.36	5.60	22.134		
1,000.00	1,000.00	985.95	985.29	3.50	2.82	19.293	119.15	41.71	126.31	119.99	6.31	20.002		
1,100.00	1,099.95	1,084.54	1,083.36	3.84	3.19	-168.478	119.44	51.84	132.91	125.89	7.02	18.924		
1,200.00	1,199.63	1,182.31	1,180.33	4.17	3.57	-164.438	119.22	64.22	145.74	138.02	7.73	18.863		
1,300.00	1,298.77	1,278.03	1,275.03	4.51	3.95	-161.030	119.11	78.17	165.11	156.68	8.43	19.584		
1,400.00	1,397.08	1,373.76	1,369.37	4.87	4.35	-158.103	118.74	94.40	190.67	181.52	9.15	20.837		
1,500.00	1,494.89	1,467.48	1,461.51	5.26	4.75	-156.030	117.92	111.53	219.26	209.40	9.87	22.221		
1,600.00	1,592.69	1,562.53	1,554.76	5.66	5.17	-154.253	117.36	129.90	248.89	238.29	10.60	23.479		
1,700.00	1,690.49	1,658.33	1,648.77	6.08	5.60	-152.810	116.45	148.33	278.36	267.01	11.35	24.521		
1,800.00	1,788.30	1,752.50	1,740.96	6.51	6.03	-151.456	115.17	167.49	308.35	296.24	12.10	25.473		
1,900.00	1,886.10	1,846.51	1,832.91	6.95	6.47	-150.280	113.81	186.99	338.66	325.79	12.87	26.321		
2,000.00	1,983.90	1,943.08	1,927.50	7.39	6.93	-149.391	112.90	206.47	369.06	355.41	13.65	27.030		
2,100.00	2,081.71	2,038.74	2,021.38	7.84	7.37	-148.799	112.47	224.84	399.27	384.83	14.43	27.662		
2,200.00	2,179.51	2,132.71	2,113.60	8.30	7.81	-148.295	112.02	242.90	429.48	414.27	15.21	28.244		
2,300.00	2,277.31	2,226.59	2,205.47	8.76	8.25	-147.676	110.86	262.13	460.04	444.06	15.99	28.773		
2,400.00	2,375.12	2,319.58	2,296.45	9.23	8.70	-147.158	110.12	281.35	491.06	474.30	16.77	29.286		
2,500.00	2,472.92	2,415.59	2,390.44	9.70	9.16	-146.733	109.67	300.94	522.17	504.60	17.57	29.712		
2,600.00	2,570.72	2,510.51	2,483.39	10.17	9.62	-146.372	109.25	320.19	553.23	534.86	18.37	30.110		
2,700.00	2,668.53	2,605.97	2,576.83	10.65	10.08	-146.015	108.55	339.69	584.21	565.03	19.18	30.456		
2,800.00	2,766.33	2,703.28	2,672.05	11.12	10.55	-145.653	107.45	359.72	615.05	595.04	20.01	30.736		
2,900.00	2,864.13	2,802.36	2,769.04	11.60	11.03	-145.308	105.96	379.93	645.54	624.68	20.86	30.952		
3,000.00	2,961.94	2,903.62	2,868.39	12.08	11.51	-145.052	104.34	399.45	675.20	653.48	21.72	31.092		
3,100.00	3,059.74	2,999.99	2,963.20	12.56	11.96	-144.967	103.64	416.62	704.43	681.91	22.53	31.273		
3,200.00	3,157.54	3,105.95	3,067.92	13.04	12.42	-145.155	104.79	432.70	733.05	709.66	23.39	31.344		
3,300.00	3,255.35	3,216.93	3,177.99	13.53	12.88	-145.482	105.97	446.87	759.99	735.73	24.26	31.322		
3,400.00	3,353.15	3,337.30	3,297.86	14.01	13.33	-146.045	107.11	457.62	784.17	759.01	25.16	31.162		
3,500.00	3,450.95	3,452.73	3,413.06	14.50	13.74	-146.679	107.64	464.85	806.34	780.34	26.01	31.007		
3,600.00	3,548.76	3,563.83	3,524.09	14.99	14.11	-147.391	107.63	468.56	826.20	799.40	26.80	30.827		
3,700.00	3,646.56	3,661.45	3,621.69	15.47	14.42	-148.016	107.49	471.10	845.59	818.06	27.53	30.713		
3,800.00	3,744.36	3,766.92	3,727.14	15.96	14.76	-148.742	107.84	472.65	864.68	836.39	28.29	30.569		
3,900.00	3,842.17	3,866.63	3,826.85	16.45	15.06	-149.464	108.44	472.98	883.33	854.33	29.00	30.457		
4,000.00	3,939.97	3,968.92	3,929.14	16.94	15.37	-150.177	108.78	473.03	901.73	872.01	29.72	30.340		
4,100.00	4,037.77	4,068.79	4,029.01	17.43	15.66	-150.844	108.82	472.81	919.86	889.45	30.41	30.244		
4,200.00	4,135.58	4,168.54	4,128.76	17.92	15.94	-151.480	108.66	472.53	937.91	906.80	31.11	30.152		
4,300.00	4,233.62	4,266.40	4,226.62	18.40	16.22	-152.213	108.53	472.14	954.94	923.16	31.79	30.042		
4,400.00	4,332.52	4,364.46	4,324.67	18.83	16.51	-152.800	108.37	471.85	967.74	935.28	32.45	29.819		
4,500.00	4,432.05	4,464.75	4,424.96	19.22	16.80	-153.181	108.26	471.50	975.95	942.84	33.11	29.473		
4,600.00	4,531.94	4,544.83	4,505.02	19.55	17.04	-153.410	109.19	470.58	980.10	946.43	33.67	29.111		
4,700.00	4,631.94	4,602.19	4,562.08	19.83	17.20	-153.816	114.18	467.77	984.19	950.15	34.03	28.917		
4,800.00	4,731.94	4,665.95	4,624.83	20.10	17.37	-154.835	124.29	462.91	992.08	957.72	34.37	28.868		
4,900.00	4,831.12	4,731.00	4,687.78	20.33	17.53	-156.303	138.98	455.72	1,001.44	966.82	34.62	28.926		

CC - Min centre to center distance or convergent point, SF - min separation factor, ES - min ellipse separation



Anticollision Report

Company:	Enduring Resources LLC	Local Co-ordinate Reference:	Well North Alamito Unit 311H
Project:	Sandoval County, New Mexico NAD83 NM C	TVD Reference:	RKB=6946+23.5 @ 6969.50ft
Reference Site:	Sec 28 T23N R07W North Alamito 4 301 311&312	MD Reference:	RKB=6946+23.5 @ 6969.50ft
Site Error:	0.00 ft	North Reference:	Grid
Reference Well:	North Alamito Unit 311H	Survey Calculation Method:	Minimum Curvature
Well Error:	0.00 ft	Output errors are at	2.00 sigma
Reference Wellbore	Original Hole	Database:	DT-Oct0825v17
Reference Design:	rev1	Offset TVD Reference:	Offset Datum

Offset Design: Sec 28 T23N R07W North Alamito 4 301 311&312 - North Alamito Unit 232H - Orig Hole - MWD surveys													Offset Site Error:	0.00 ft
Survey Program: 365-MWD													Offset Well Error:	0.00 ft
Reference		Offset		Semi Major Axis		Highside Toolface (°)	Offset Wellbore Centre		Distance		Minimum Separation (ft)	Separation Factor	Warning	
Measured Depth (ft)	Vertical Depth (ft)	Measured Depth (ft)	Vertical Depth (ft)	Reference (ft)	Offset (ft)		+N/-S (ft)	+E/-W (ft)	Between Centres (ft)	Between Ellipses (ft)				
5,000.00	4,926.76	4,794.90	4,748.29	20.50	17.68	77.384	157.44	446.85	1,010.83	976.04	34.79	29.054		
5,100.00	5,015.95	4,873.23	4,820.35	20.60	17.84	77.005	184.76	433.02	1,019.30	984.26	35.04	29.091		
5,200.00	5,095.98	4,948.47	4,886.79	20.64	17.98	77.109	215.47	415.66	1,025.98	990.68	35.30	29.068		
5,300.00	5,164.42	5,011.92	4,940.54	20.65	18.09	77.517	244.81	399.08	1,032.01	996.44	35.57	29.012		
5,400.00	5,219.19	5,074.79	4,990.97	20.62	18.20	78.211	277.51	380.70	1,038.17	1,002.14	36.03	28.811		
5,500.00	5,258.63	5,132.00	5,033.33	20.58	18.28	79.043	310.89	361.69	1,045.10	1,008.40	36.70	28.479		
5,600.00	5,281.76	5,182.59	5,068.06	20.59	18.35	79.891	343.18	344.08	1,056.23	1,018.64	37.59	28.097		
5,700.00	5,288.14	5,233.75	5,100.23	21.27	18.42	80.264	378.21	325.27	1,072.87	1,034.14	38.73	27.698		
5,800.00	5,287.90	5,307.49	5,141.60	22.38	18.54	82.642	432.10	296.70	1,094.64	1,054.39	40.24	27.200		
5,900.00	5,287.65	5,373.96	5,172.83	23.67	18.88	84.414	483.45	268.38	1,119.27	1,077.44	41.82	26.761		
6,000.00	5,287.41	5,439.26	5,196.99	25.10	19.37	85.775	536.85	239.64	1,147.31	1,103.79	43.51	26.366		
6,100.00	5,287.16	5,556.27	5,236.23	26.66	20.43	87.905	633.96	187.49	1,176.94	1,130.93	46.02	25.575		
6,200.00	5,286.92	5,635.39	5,256.46	28.32	21.26	88.962	700.71	150.24	1,206.11	1,157.87	48.24	25.002		
6,300.00	5,286.67	5,729.38	5,267.48	30.06	22.33	89.533	782.33	105.17	1,236.22	1,185.37	50.85	24.313		
6,400.00	5,286.43	5,842.14	5,266.65	31.88	23.74	89.519	880.64	49.97	1,265.81	1,211.86	53.96	23.461		
6,500.00	5,286.18	5,949.73	5,263.86	33.75	25.21	89.414	973.83	-3.74	1,294.34	1,237.15	57.19	22.631		
6,600.00	5,285.94	6,116.59	5,263.11	35.68	27.72	89.418	1,115.87	-91.19	1,320.30	1,258.47	61.82	21.356		
6,700.00	5,285.69	6,262.28	5,265.28	37.65	30.10	89.541	1,236.18	-173.32	1,341.45	1,275.17	66.28	20.240		
8,100.00	5,282.27	7,971.47	5,260.59	67.62	64.64	89.529	2,431.13	-1,390.78	1,346.34	1,215.12	131.22	10.260		
8,200.00	5,282.02	8,041.00	5,260.62	69.85	66.17	89.537	2,477.76	-1,442.34	1,343.96	1,208.75	135.21	9.940		
8,300.00	5,281.78	8,145.69	5,260.83	72.09	68.49	89.557	2,548.85	-1,519.19	1,342.72	1,202.96	139.76	9.607		
8,400.00	5,281.53	8,258.89	5,261.30	74.33	71.00	89.588	2,625.12	-1,602.85	1,340.76	1,196.29	144.46	9.281		
8,500.00	5,281.29	8,344.00	5,261.82	76.57	72.89	89.618	2,682.19	-1,665.98	1,338.41	1,189.68	148.72	8.999		
8,555.68	5,281.15	8,379.79	5,262.00	77.82	73.69	89.629	2,706.63	-1,692.13	1,337.99	1,187.11	150.88	8.868		
8,600.00	5,281.04	8,409.57	5,262.07	78.82	74.35	89.636	2,727.25	-1,713.61	1,338.25	1,185.66	152.59	8.770		
8,700.00	5,280.80	8,513.12	5,262.17	81.07	76.66	89.651	2,799.36	-1,787.92	1,339.40	1,182.24	157.16	8.523		
8,800.00	5,280.55	8,633.53	5,262.14	83.33	79.35	89.663	2,882.37	-1,875.14	1,339.58	1,177.53	162.05	8.266		
8,900.00	5,280.31	8,747.08	5,262.13	85.59	81.90	89.674	2,959.45	-1,958.53	1,338.27	1,171.46	166.81	8.023		
9,000.00	5,280.06	8,861.11	5,262.41	87.85	84.47	89.697	3,036.00	-2,043.04	1,335.97	1,164.40	171.57	7.787		
9,100.00	5,279.82	8,956.00	5,262.58	90.12	86.62	89.714	3,099.53	-2,113.52	1,333.43	1,157.38	176.04	7.574		
9,200.00	5,279.57	9,063.89	5,262.29	92.39	89.06	89.712	3,171.86	-2,193.58	1,331.02	1,150.30	180.72	7.365		
9,300.00	5,279.33	9,191.74	5,261.75	94.66	91.97	89.701	3,255.91	-2,289.90	1,326.84	1,141.19	185.65	7.147		
9,400.00	5,279.08	9,280.28	5,261.74	96.93	93.99	89.709	3,313.40	-2,357.25	1,321.66	1,131.57	190.09	6.953		
9,500.00	5,278.84	9,392.96	5,262.20	99.21	96.56	89.740	3,387.46	-2,442.16	1,317.56	1,122.73	194.82	6.763		
9,600.00	5,278.59	9,459.84	5,262.69	101.49	98.09	89.768	3,431.57	-2,492.42	1,313.67	1,114.69	198.98	6.602		
9,700.00	5,278.35	9,550.52	5,263.18	103.77	100.16	89.799	3,492.75	-2,559.35	1,311.78	1,108.37	203.41	6.449		
9,800.00	5,278.10	9,671.93	5,262.98	106.05	102.93	89.802	3,573.86	-2,649.69	1,309.05	1,100.75	208.31	6.284		
9,900.00	5,277.86	9,748.00	5,263.18	108.34	104.67	89.819	3,624.28	-2,706.65	1,305.78	1,093.24	212.54	6.144		
10,000.00	5,277.61	9,833.11	5,264.03	110.62	106.62	89.865	3,681.98	-2,769.21	1,304.41	1,087.54	216.87	6.015		
10,100.00	5,277.37	9,949.12	5,264.15	112.91	109.27	89.883	3,760.86	-2,854.27	1,303.31	1,081.58	221.73	5.878		
10,200.00	5,277.12	10,078.15	5,262.63	115.20	112.23	89.829	3,846.39	-2,950.85	1,299.76	1,073.02	226.74	5.732		
10,300.00	5,276.88	10,140.47	5,261.77	117.49	113.67	89.798	3,887.97	-2,997.27	1,296.99	1,066.20	230.79	5.620		
10,334.97	5,276.79	10,159.85	5,261.60	118.29	114.11	89.793	3,901.22	-3,011.41	1,296.78	1,064.68	232.10	5.587		
10,400.00	5,276.63	10,208.87	5,261.59	119.78	115.23	89.797	3,935.28	-3,046.66	1,297.32	1,062.59	234.74	5.527		
10,500.00	5,276.39	10,305.18	5,263.05	122.08	117.42	89.873	4,002.58	-3,115.55	1,298.79	1,059.56	239.23	5.429		
10,600.00	5,276.14	10,431.76	5,265.17	124.37	120.32	89.980	4,089.80	-3,207.23	1,298.84	1,054.46	244.38	5.315		
10,700.00	5,275.90	10,550.48	5,265.48	126.67	123.05	90.006	4,170.51	-3,294.31	1,297.71	1,048.41	249.30	5.205		
10,800.00	5,275.65	10,633.17	5,264.77	128.96	124.95	89.984	4,226.70	-3,354.97	1,296.50	1,042.90	253.61	5.112		
10,900.00	5,275.41	10,742.22	5,265.45	131.26	127.45	90.026	4,300.85	-3,434.92	1,295.38	1,037.00	258.37	5.014		
10,966.56	5,275.25	10,791.57	5,266.39	132.79	128.59	90.073	4,334.55	-3,470.95	1,294.91	1,033.79	261.12	4.959		
11,000.00	5,275.16	10,817.77	5,267.06	133.56	129.19	90.105	4,352.63	-3,489.89	1,295.02	1,032.52	262.50	4.933		

CC - Min centre to center distance or convergent point, SF - min separation factor, ES - min ellipse separation



Anticollision Report

Company:	Enduring Resources LLC	Local Co-ordinate Reference:	Well North Alamito Unit 311H
Project:	Sandoval County, New Mexico NAD83 NM C	TVD Reference:	RKB=6946+23.5 @ 6969.50ft
Reference Site:	Sec 28 T23N R07W North Alamito 4 301 311&312	MD Reference:	RKB=6946+23.5 @ 6969.50ft
Site Error:	0.00 ft	North Reference:	Grid
Reference Well:	North Alamito Unit 311H	Survey Calculation Method:	Minimum Curvature
Well Error:	0.00 ft	Output errors are at	2.00 sigma
Reference Wellbore	Original Hole	Database:	DT-Oct0825v17
Reference Design:	rev1	Offset TVD Reference:	Offset Datum

Offset Design: Sec 28 T23N R07W North Alamito 4 301 311&312 - North Alamito Unit 232H - Orig Hole - MWD surveys													Offset Site Error:	0.00 ft
Survey Program: 365-MWD													Offset Well Error:	0.00 ft
Measured Depth (ft)	Vertical Depth (ft)	Offset		Semi Major Axis		Highside Toolface (°)	Offset Wellbore Centre		Distance		Minimum Separation (ft)	Separation Factor	Warning	
		Measured Depth (ft)	Vertical Depth (ft)	Reference (ft)	Offset (ft)		+N/-S (ft)	+E/-W (ft)	Between Centres (ft)	Between Ellipses (ft)				
11,100.00	5,274.92	10,974.91	5,271.10	135.86	132.80	90.302	4,459.50	-3,604.99	1,294.30	1,026.27	268.03	4.829		
11,200.00	5,274.67	11,073.53	5,271.47	138.16	135.09	90.329	4,524.53	-3,679.14	1,290.41	1,017.77	272.64	4.733		
11,300.00	5,274.43	11,207.08	5,271.63	140.46	138.19	90.353	4,611.21	-3,780.74	1,285.07	1,007.56	277.52	4.631		
11,400.00	5,274.19	11,318.25	5,271.51	142.76	140.78	90.362	4,681.94	-3,866.50	1,278.13	995.95	282.18	4.530		
11,476.02	5,274.00	11,350.00	5,271.51	144.51	141.52	90.366	4,702.06	-3,891.06	1,273.39	987.94	285.45	4.461 SF		

CC - Min centre to center distance or convergent point, SF - min separation factor, ES - min ellipse separation



Anticollision Report

Company:	Enduring Resources LLC	Local Co-ordinate Reference:	Well North Alamito Unit 311H
Project:	Sandoval County, New Mexico NAD83 NM C	TVD Reference:	RKB=6946+23.5 @ 6969.50ft
Reference Site:	Sec 28 T23N R07W North Alamito 4 301 311&312	MD Reference:	RKB=6946+23.5 @ 6969.50ft
Site Error:	0.00 ft	North Reference:	Grid
Reference Well:	North Alamito Unit 311H	Survey Calculation Method:	Minimum Curvature
Well Error:	0.00 ft	Output errors are at	2.00 sigma
Reference Wellbore	Original Hole	Database:	DT-Oct0825v17
Reference Design:	rev1	Offset TVD Reference:	Offset Datum

Offset Design: Sec 28 T23N R07W North Alamito 4 301 311&312 - North Alamito Unit 233H - Orig Hole - MWD surveys													Offset Site Error:	0.00 ft
Survey Program: 365-MWD													Offset Well Error:	0.00 ft
Measured Depth (ft)	Vertical Depth (ft)	Offset		Semi Major Axis		Highside Toolface (°)	Offset Wellbore Centre		Distance		Minimum Separation (ft)	Separation Factor	Warning	
		Measured Depth (ft)	Vertical Depth (ft)	Reference (ft)	Offset (ft)		+N/-S (ft)	+E/-W (ft)	Between Centres (ft)	Between Ellipses (ft)				
0.00	0.00	0.00	0.00	0.00	0.00	12.415	90.03	19.82	92.78					
100.00	100.00	89.27	89.27	0.27	0.15	12.454	90.13	19.90	92.30	91.87	0.43	215.495	CC	
200.00	200.00	189.01	189.01	0.63	0.33	12.586	90.46	20.20	92.69	91.73	0.96	96.669		
300.00	300.00	288.74	288.74	0.99	0.50	12.809	91.04	20.70	93.36	91.87	1.49	62.688		
400.00	400.00	388.63	388.62	1.35	0.71	13.082	91.85	21.34	94.30	92.24	2.06	45.718		
500.00	500.00	489.33	489.31	1.71	1.06	12.287	92.74	20.20	94.91	92.14	2.77	34.242		
600.00	600.00	589.07	588.97	2.07	1.41	9.921	93.78	16.40	95.21	91.73	3.48	27.367	ES	
700.00	700.00	688.58	688.37	2.43	1.77	7.247	95.35	12.12	96.12	91.93	4.19	22.929		
800.00	800.00	787.93	787.61	2.78	2.13	4.645	97.20	7.90	97.54	92.63	4.91	19.874		
900.00	900.00	884.55	884.09	3.14	2.48	2.405	100.73	4.23	100.97	95.35	5.61	17.987		
1,000.00	1,000.00	980.05	979.29	3.50	2.83	1.065	107.95	2.01	108.45	102.14	6.31	17.198	SF	
1,100.00	1,099.95	1,075.31	1,073.98	3.84	3.18	168.717	118.27	0.65	121.83	114.85	6.98	17.461		
1,200.00	1,199.63	1,166.41	1,164.03	4.17	3.53	168.950	131.95	0.27	144.41	136.80	7.61	18.980		
1,300.00	1,298.77	1,254.30	1,250.23	4.51	3.89	169.365	149.11	0.06	176.35	168.13	8.22	21.448		
1,400.00	1,397.08	1,343.67	1,337.27	4.87	4.27	169.835	169.33	-0.06	216.06	207.19	8.87	24.368		
1,500.00	1,494.89	1,429.52	1,420.67	5.26	4.65	170.353	189.71	-0.37	259.23	249.75	9.48	27.344		
1,600.00	1,592.69	1,515.89	1,504.22	5.66	5.06	170.684	211.56	-0.84	303.86	293.76	10.10	30.085		
1,700.00	1,690.49	1,606.25	1,591.55	6.08	5.49	170.889	234.77	-1.61	348.82	338.06	10.77	32.399		
1,800.00	1,788.30	1,696.29	1,678.69	6.51	5.93	171.161	257.43	-1.69	393.36	381.92	11.44	34.398		
1,900.00	1,886.10	1,781.29	1,760.84	6.95	6.36	171.416	279.30	-1.40	438.43	426.37	12.06	36.341		
2,000.00	1,983.90	1,871.17	1,847.54	7.39	6.81	171.647	302.94	-0.98	484.06	471.32	12.74	37.987		
2,100.00	2,081.71	1,965.77	1,939.00	7.84	7.29	171.776	327.14	-1.17	528.99	515.52	13.47	39.280		
2,200.00	2,179.51	2,061.13	2,031.43	8.30	7.78	171.820	350.59	-2.01	572.95	558.75	14.20	40.352		
2,300.00	2,277.31	2,141.60	2,109.38	8.76	8.19	171.926	370.54	-2.00	617.17	602.36	14.81	41.685		
2,400.00	2,375.12	2,231.45	2,196.22	9.23	8.65	172.074	393.60	-1.46	662.22	646.73	15.50	42.736		
2,500.00	2,472.92	2,327.99	2,289.70	9.70	9.15	172.159	417.71	-1.52	706.59	690.35	16.24	43.498		
2,600.00	2,570.72	2,417.91	2,376.88	10.17	9.61	172.244	439.74	-1.44	750.54	733.60	16.94	44.312		
2,700.00	2,668.53	2,505.82	2,462.11	10.65	10.06	172.356	461.27	-0.87	794.53	776.91	17.62	45.103		
2,800.00	2,766.33	2,590.48	2,544.03	11.12	10.50	172.466	482.60	-0.11	839.17	820.90	18.27	45.934		
2,900.00	2,864.13	2,681.85	2,632.47	11.60	10.98	172.519	505.56	-0.05	883.71	864.72	18.98	46.558		
3,000.00	2,961.94	2,778.07	2,725.60	12.08	11.48	172.537	529.77	-0.44	928.25	908.52	19.73	47.038		
3,100.00	3,059.74	2,878.51	2,823.18	12.56	11.99	172.526	553.53	-1.41	971.33	950.81	20.52	47.339		
3,200.00	3,157.54	2,979.92	2,921.80	13.04	12.51	172.567	577.15	-1.59	1,014.20	992.89	21.31	47.598		
3,300.00	3,255.35	3,064.49	3,004.20	13.53	12.93	172.586	596.16	-2.01	1,056.25	1,034.28	21.97	48.087		
3,400.00	3,353.15	3,139.92	3,077.53	14.01	13.32	172.624	613.85	-1.94	1,099.25	1,076.69	22.55	48.743		
3,500.00	3,450.95	3,218.96	3,154.11	14.50	13.73	172.699	633.39	-1.10	1,143.46	1,120.30	23.17	49.356		
3,600.00	3,548.76	3,318.83	3,250.94	14.99	14.25	172.773	657.82	-0.33	1,187.42	1,163.47	23.95	49.575		
3,700.00	3,646.56	3,399.02	3,328.66	15.47	14.66	172.810	677.57	-0.04	1,231.52	1,206.94	24.58	50.103		
3,800.00	3,744.36	3,493.64	3,420.34	15.96	15.16	172.838	701.00	0.06	1,275.72	1,250.40	25.32	50.374		
3,900.00	3,842.17	3,574.10	3,498.24	16.45	15.58	172.898	721.11	0.94	1,320.21	1,294.25	25.96	50.864		

CC - Min centre to center distance or convergent point, SF - min separation factor, ES - min ellipse separation



Anticollision Report

Company:	Enduring Resources LLC	Local Co-ordinate Reference:	Well North Alamito Unit 311H
Project:	Sandoval County, New Mexico NAD83 NM C	TVD Reference:	RKB=6946+23.5 @ 6969.50ft
Reference Site:	Sec 28 T23N R07W North Alamito 4 301 311&312	MD Reference:	RKB=6946+23.5 @ 6969.50ft
Site Error:	0.00 ft	North Reference:	Grid
Reference Well:	North Alamito Unit 311H	Survey Calculation Method:	Minimum Curvature
Well Error:	0.00 ft	Output errors are at	2.00 sigma
Reference Wellbore	Original Hole	Database:	DT-Oct0825v17
Reference Design:	rev1	Offset TVD Reference:	Offset Datum

Offset Design: Sec 28 T23N R07W North Alamito 4 301 311&312 - North Alamito Unit 301H - Original Hole - rev1													Offset Site Error:	0.00 ft
Survey Program: 0-MWD													Offset Well Error:	0.00 ft
Measured Depth (ft)	Vertical Reference Depth (ft)	Offset		Semi Major Axis		Highside Toolface (°)	Offset Wellbore Centre		Distance		Minimum Separation (ft)	Separation Factor	Warning	
		Measured Depth (ft)	Vertical Depth (ft)	Reference (ft)	Offset (ft)		+N/-S (ft)	+E/-W (ft)	Between Centres (ft)	Between Ellipses (ft)				
0.00	0.00	0.00	0.00	0.00	0.00	89.736	0.28	59.92	59.92					
100.00	100.00	100.00	100.00	0.27	0.27	89.736	0.28	59.92	59.92	59.37	0.55	109.245		
200.00	200.00	200.00	200.00	0.63	0.63	89.736	0.28	59.92	59.92	58.65	1.27	47.350		
300.00	300.00	300.00	300.00	0.99	0.99	89.736	0.28	59.92	59.92	57.93	1.98	30.225		
400.00	400.00	400.00	400.00	1.35	1.35	89.736	0.28	59.92	59.92	57.22	2.70	22.197		
500.00	500.00	500.00	500.00	1.71	1.71	89.736	0.28	59.92	59.92	56.50	3.42	17.539		
600.00	600.00	600.00	600.00	2.07	2.07	89.736	0.28	59.92	59.92	55.78	4.13	14.497		
700.00	700.00	700.00	700.00	2.43	2.43	89.736	0.28	59.92	59.92	55.07	4.85	12.354		
800.00	800.00	800.00	800.00	2.78	2.78	89.736	0.28	59.92	59.92	54.35	5.57	10.763 CC, ES		
900.00	900.00	898.94	898.89	3.14	3.14	87.442	2.71	60.71	60.78	54.50	6.28	9.681		
1,000.00	1,000.00	997.35	996.99	3.50	3.50	81.023	9.96	63.07	63.92	56.94	6.98	9.151 SF		
1,100.00	1,099.95	1,094.28	1,093.12	3.84	3.85	-121.329	21.79	66.92	72.04	64.38	7.66	9.404		
1,200.00	1,199.63	1,188.18	1,185.51	4.17	4.20	-133.747	37.66	72.08	89.45	81.16	8.29	10.785		
1,300.00	1,298.77	1,277.77	1,272.80	4.51	4.57	-144.078	56.81	78.31	118.12	109.23	8.89	13.285		
1,400.00	1,397.08	1,362.01	1,353.93	4.87	4.94	-151.391	78.34	85.31	157.71	148.26	9.45	16.690		
1,500.00	1,494.89	1,441.36	1,429.38	5.26	5.32	-156.745	101.73	92.92	205.00	195.04	9.96	20.588		
1,600.00	1,592.69	1,516.92	1,500.20	5.66	5.70	-160.263	126.74	101.05	256.76	246.33	10.43	24.615		
1,700.00	1,690.49	1,588.72	1,566.49	6.08	6.10	-162.700	152.96	109.58	312.31	301.43	10.88	28.710		
1,800.00	1,788.30	1,656.85	1,628.39	6.51	6.51	-164.463	180.01	118.39	371.18	359.88	11.30	32.842		
1,900.00	1,886.10	1,721.43	1,686.09	6.95	6.92	-165.782	207.58	127.35	433.03	421.33	11.70	37.004		
2,000.00	1,983.90	1,782.58	1,739.81	7.39	7.34	-166.797	235.38	136.40	497.56	485.48	12.08	41.184		
2,100.00	2,081.71	1,840.47	1,789.76	7.84	7.76	-167.596	263.19	145.44	564.53	552.09	12.44	45.374		
2,200.00	2,179.51	1,900.00	1,840.18	8.30	8.20	-168.289	293.28	155.23	633.75	620.90	12.85	49.333		
2,300.00	2,277.31	1,952.42	1,883.81	8.76	8.62	-168.810	320.92	164.22	704.88	691.70	13.18	53.488		
2,400.00	2,375.12	2,021.94	1,941.46	9.23	9.20	-169.392	357.86	176.24	776.56	762.81	13.75	56.458		
2,500.00	2,472.92	2,091.47	1,999.12	9.70	9.78	-169.877	394.81	188.26	848.28	833.94	14.34	59.166		
2,600.00	2,570.72	2,161.00	2,056.78	10.17	10.38	-170.286	431.76	200.28	920.01	905.09	14.93	61.631		
2,700.00	2,668.53	2,230.53	2,114.44	10.65	10.99	-170.636	468.71	212.30	991.77	976.25	15.52	63.887		
2,800.00	2,766.33	2,300.05	2,172.09	11.12	11.60	-170.939	505.66	224.32	1,063.55	1,047.42	16.12	65.957		
2,900.00	2,864.13	2,369.58	2,229.75	11.60	12.22	-171.204	542.61	236.34	1,135.34	1,118.60	16.73	67.855		
3,000.00	2,961.94	2,439.11	2,287.41	12.08	12.85	-171.438	579.55	248.36	1,207.13	1,189.79	17.34	69.604		
3,100.00	3,059.74	2,508.63	2,345.07	12.56	13.48	-171.645	616.50	260.38	1,278.94	1,260.98	17.96	71.222		

CC - Min centre to center distance or convergent point, SF - min separation factor, ES - min ellipse separation



Anticollision Report

Company:	Enduring Resources LLC	Local Co-ordinate Reference:	Well North Alamito Unit 311H
Project:	Sandoval County, New Mexico NAD83 NM C	TVD Reference:	RKB=6946+23.5 @ 6969.50ft
Reference Site:	Sec 28 T23N R07W North Alamito 4 301 311&312	MD Reference:	RKB=6946+23.5 @ 6969.50ft
Site Error:	0.00 ft	North Reference:	Grid
Reference Well:	North Alamito Unit 311H	Survey Calculation Method:	Minimum Curvature
Well Error:	0.00 ft	Output errors are at	2.00 sigma
Reference Wellbore	Original Hole	Database:	DT-Oct0825v17
Reference Design:	rev1	Offset TVD Reference:	Offset Datum

Offset Design: Sec 28 T23N R07W North Alamito 4 301 311&312 - North Alamito Unit 312H - Original Hole - rev1													Offset Site Error:	0.00 ft
Survey Program: 0-MWD													Offset Well Error:	0.00 ft
Reference	Offset	Semi Major Axis		Highside	Offset Wellbore Centre		Distance		Minimum	Separation	Warning			
Measured Depth (ft)	Vertical Depth (ft)	Measured Depth (ft)	Vertical Depth (ft)	Reference (ft)	Offset (ft)	Toolface (°)	+N/-S (ft)	+E/-W (ft)	Between Centres (ft)	Between Ellipses (ft)	Separation (ft)	Factor		
0.00	0.00	0.00	0.00	0.00	0.00	89.725	0.09	19.78	19.78					
100.00	100.00	100.00	100.00	0.27	0.27	89.725	0.09	19.78	19.78	19.23	0.55	36.057		
200.00	200.00	200.00	200.00	0.63	0.63	89.725	0.09	19.78	19.78	18.51	1.27	15.628		
300.00	300.00	300.00	300.00	0.99	0.99	89.725	0.09	19.78	19.78	17.79	1.98	9.976		
400.00	400.00	400.00	400.00	1.35	1.35	89.725	0.09	19.78	19.78	17.08	2.70	7.326		
500.00	500.00	500.00	500.00	1.71	1.71	89.725	0.09	19.78	19.78	16.36	3.42	5.789		
600.00	600.00	600.00	600.00	2.07	2.07	89.725	0.09	19.78	19.78	15.64	4.13	4.785		
700.00	700.00	700.00	700.00	2.43	2.43	89.725	0.09	19.78	19.78	14.93	4.85	4.077		
800.00	800.00	800.00	800.00	2.78	2.78	89.725	0.09	19.78	19.78	14.21	5.57	3.552		
900.00	900.00	900.00	900.00	3.14	3.14	89.725	0.09	19.78	19.78	13.49	6.28	3.147		
1,000.00	1,000.00	1,000.00	1,000.00	3.50	3.50	89.725	0.09	19.78	19.78	12.77	7.00	2.825 CC, ES		
1,100.00	1,099.95	1,099.95	1,099.95	3.84	3.86	-109.184	0.09	19.78	20.48	12.78	7.70	2.660 SF		
1,200.00	1,199.63	1,199.63	1,199.63	4.17	4.22	-126.865	0.09	19.78	24.22	15.84	8.39	2.888		
1,300.00	1,298.77	1,300.36	1,300.31	4.51	4.57	-146.462	-1.01	17.38	31.28	22.22	9.06	3.452		
1,400.00	1,397.08	1,400.86	1,400.49	4.87	4.91	-164.589	-4.33	10.20	41.18	31.46	9.72	4.236		
1,500.00	1,494.89	1,501.15	1,499.91	5.26	5.26	-179.663	-9.85	-1.73	52.83	42.42	10.40	5.077		
1,600.00	1,592.69	1,600.30	1,597.54	5.66	5.62	167.831	-17.08	-17.38	64.78	53.64	11.14	5.817		
1,700.00	1,690.49	1,698.74	1,694.41	6.08	6.00	159.197	-24.44	-33.32	78.67	66.78	11.89	6.614		
1,800.00	1,788.30	1,797.19	1,791.28	6.51	6.38	153.223	-31.81	-49.25	93.79	81.12	12.67	7.403		
1,900.00	1,886.10	1,895.64	1,888.15	6.95	6.78	148.931	-39.17	-65.19	109.64	96.18	13.46	8.145		
2,000.00	1,983.90	1,994.09	1,985.02	7.39	7.18	145.730	-46.54	-81.13	125.93	111.67	14.27	8.827		
2,100.00	2,081.71	2,092.54	2,081.90	7.84	7.59	143.266	-53.90	-97.06	142.52	127.44	15.09	9.448		
2,200.00	2,179.51	2,190.99	2,178.77	8.30	8.01	141.317	-61.27	-113.00	159.32	143.40	15.91	10.011		
2,300.00	2,277.31	2,289.44	2,275.64	8.76	8.43	139.740	-68.63	-128.93	176.26	159.51	16.75	10.522		
2,400.00	2,375.12	2,387.89	2,372.51	9.23	8.85	138.440	-76.00	-144.87	193.30	175.71	17.60	10.986		
2,500.00	2,472.92	2,486.34	2,469.38	9.70	9.28	137.351	-83.36	-160.80	210.43	191.98	18.45	11.407		
2,600.00	2,570.72	2,584.79	2,566.26	10.17	9.71	136.426	-90.73	-176.74	227.62	208.32	19.30	11.792		
2,700.00	2,668.53	2,683.24	2,663.13	10.65	10.14	135.631	-98.09	-192.68	244.86	224.70	20.17	12.143		
2,800.00	2,766.33	2,781.69	2,760.00	11.12	10.58	134.941	-105.45	-208.61	262.14	241.11	21.03	12.464		
2,900.00	2,864.13	2,880.14	2,856.87	11.60	11.01	134.336	-112.82	-224.55	279.45	257.55	21.90	12.760		
3,000.00	2,961.94	2,978.59	2,953.74	12.08	11.45	133.801	-120.18	-240.48	296.79	274.02	22.77	13.032		
3,100.00	3,059.74	3,077.04	3,050.62	12.56	11.89	133.326	-127.55	-256.42	314.15	290.50	23.65	13.284		
3,200.00	3,157.54	3,175.49	3,147.49	13.04	12.33	132.900	-134.91	-272.35	331.53	307.00	24.53	13.517		
3,300.00	3,255.35	3,273.94	3,244.36	13.53	12.78	132.517	-142.28	-288.29	348.93	323.52	25.41	13.733		
3,400.00	3,353.15	3,372.39	3,341.23	14.01	13.22	132.170	-149.64	-304.23	366.34	340.04	26.29	13.934		
3,500.00	3,450.95	3,470.84	3,438.10	14.50	13.66	131.854	-157.01	-320.16	383.76	356.58	27.18	14.121		
3,600.00	3,548.76	3,569.29	3,534.98	14.99	14.11	131.566	-164.37	-336.10	401.19	373.13	28.06	14.296		
3,700.00	3,646.56	3,667.74	3,631.85	15.47	14.56	131.302	-171.74	-352.03	418.63	389.68	28.95	14.460		
3,800.00	3,744.36	3,769.40	3,732.09	15.96	15.00	131.222	-178.80	-367.32	435.83	405.98	29.85	14.600		
3,900.00	3,842.17	3,872.64	3,834.64	16.45	15.42	131.811	-183.79	-378.10	452.05	421.34	30.71	14.722		
4,000.00	3,939.97	3,975.46	3,937.25	16.94	15.79	133.029	-186.43	-383.83	467.38	435.89	31.49	14.842		
4,100.00	4,037.77	4,076.00	4,037.77	17.43	16.12	134.738	-186.91	-384.85	482.17	449.98	32.19	14.978		
4,200.00	4,135.58	4,173.80	4,135.58	17.92	16.42	136.426	-186.91	-384.85	497.22	464.37	32.85	15.135		
4,300.00	4,233.62	4,271.84	4,233.62	18.40	16.72	138.126	-186.91	-384.85	511.77	478.26	33.51	15.272		
4,400.00	4,332.52	4,370.74	4,332.52	18.83	17.03	139.418	-186.91	-384.85	522.91	488.75	34.16	15.308		
4,500.00	4,432.05	4,470.27	4,432.05	19.22	17.34	140.229	-186.91	-384.85	530.22	495.41	34.81	15.234		
4,600.00	4,531.94	4,570.17	4,531.94	19.55	17.65	140.589	-186.91	-384.85	533.55	498.11	35.44	15.053		
4,700.00	4,631.94	4,670.17	4,631.94	19.83	17.97	-27.634	-186.91	-384.85	533.76	497.70	36.06	14.802		
4,800.00	4,731.94	4,893.75	4,854.11	20.10	18.63	15.466	-198.71	-372.29	531.49	495.02	36.46	14.576		
4,900.00	4,831.12	5,305.76	5,185.63	20.33	19.37	40.559	-355.84	-205.05	465.09	437.17	27.92	16.658		
5,000.00	4,926.76	5,380.08	5,223.87	20.50	19.44	74.536	-399.43	-158.65	375.91	348.65	27.26	13.790		

CC - Min centre to center distance or convergent point, SF - min separation factor, ES - min ellipse separation



Anticollision Report

Company:	Enduring Resources LLC	Local Co-ordinate Reference:	Well North Alamito Unit 311H
Project:	Sandoval County, New Mexico NAD83 NM C	TVD Reference:	RKB=6946+23.5 @ 6969.50ft
Reference Site:	Sec 28 T23N R07W North Alamito 4 301 311&312	MD Reference:	RKB=6946+23.5 @ 6969.50ft
Site Error:	0.00 ft	North Reference:	Grid
Reference Well:	North Alamito Unit 311H	Survey Calculation Method:	Minimum Curvature
Well Error:	0.00 ft	Output errors are at	2.00 sigma
Reference Wellbore	Original Hole	Database:	DT-Oct0825v17
Reference Design:	rev1	Offset TVD Reference:	Offset Datum

Offset Design: Sec 28 T23N R07W North Alamito 4 301 311&312 - North Alamito Unit 312H - Original Hole - rev1													Offset Site Error:	0.00 ft
Survey Program: 0-MWD													Offset Well Error:	0.00 ft
Measured Depth (ft)	Vertical Reference Depth (ft)	Offset		Semi Major Axis		Highside Toolface (°)	Offset Wellbore Centre		Distance		Minimum Separation (ft)	Separation Factor	Warning	
		Measured Depth (ft)	Vertical Depth (ft)	Reference (ft)	Offset (ft)		+N/-S (ft)	+E/-W (ft)	Between Centres (ft)	Between Ellipses (ft)				
5,100.00	5,015.95	5,381.85	5,224.68	20.60	19.44	92.932	-400.51	-157.50	288.72	259.24	29.49	9.792		
5,200.00	5,095.98	5,360.13	5,214.42	20.64	19.42	97.209	-387.40	-171.45	212.80	179.34	33.46	6.359		
5,300.00	5,164.42	5,328.09	5,197.98	20.65	19.39	92.051	-368.57	-191.49	163.16	125.57	37.59	4.341		
5,354.36	5,196.00	5,308.23	5,187.03	20.63	19.37	86.046	-357.23	-203.56	155.20	117.74	37.46	4.143		
5,400.00	5,219.19	5,290.65	5,176.86	20.62	19.36	79.602	-347.41	-214.02	160.59	125.02	35.57	4.515		
5,500.00	5,258.63	5,250.00	5,151.70	20.58	19.31	63.134	-325.56	-237.28	201.45	170.08	31.37	6.421		
5,600.00	5,281.76	5,207.47	5,123.02	20.59	19.25	47.117	-304.06	-260.16	262.86	232.42	30.44	8.636		
5,700.00	5,288.14	5,163.72	5,091.18	21.27	19.19	35.121	-283.53	-282.01	329.88	298.66	31.21	10.568		
5,800.00	5,287.90	5,123.95	5,060.32	22.38	19.12	31.298	-266.36	-300.28	401.43	369.07	32.35	12.407		
5,900.00	5,287.65	5,100.00	5,040.92	23.67	19.08	29.256	-256.74	-310.52	478.74	444.96	33.78	14.171		
6,000.00	5,287.41	5,050.00	4,998.63	25.10	18.99	25.554	-238.50	-329.94	560.09	526.19	33.89	16.525		
6,100.00	5,287.16	5,050.00	4,998.63	26.66	18.99	25.554	-238.50	-329.94	644.55	609.22	35.33	18.243		
6,200.00	5,286.92	5,015.89	4,968.52	28.32	18.92	23.411	-227.53	-341.61	731.14	695.55	35.59	20.544		
6,300.00	5,286.67	5,000.00	4,954.18	30.06	18.88	22.505	-222.84	-346.60	819.94	783.82	36.12	22.700		
6,400.00	5,286.43	4,981.23	4,937.01	31.88	18.84	21.504	-217.66	-352.12	910.24	873.77	36.47	24.956		
6,500.00	5,286.18	4,966.94	4,923.77	33.75	18.81	20.789	-213.98	-356.04	1,001.81	965.00	36.80	27.219		
6,600.00	5,285.94	4,950.00	4,907.91	35.68	18.77	19.989	-209.90	-360.38	1,094.42	1,057.38	37.03	29.551		
6,700.00	5,285.69	4,950.00	4,907.91	37.65	18.77	19.989	-209.90	-360.38	1,187.90	1,150.51	37.39	31.771		
6,800.00	5,285.45	4,950.00	4,907.91	39.66	18.77	19.989	-209.90	-360.38	1,282.36	1,244.69	37.67	34.041		

CC - Min centre to center distance or convergent point, SF - min separation factor, ES - min ellipse separation



Anticollision Report

Company:	Enduring Resources LLC	Local Co-ordinate Reference:	Well North Alamito Unit 311H
Project:	Sandoval County, New Mexico NAD83 NM C	TVD Reference:	RKB=6946+23.5 @ 6969.50ft
Reference Site:	Sec 28 T23N R07W North Alamito 4 301 311&312	MD Reference:	RKB=6946+23.5 @ 6969.50ft
Site Error:	0.00 ft	North Reference:	Grid
Reference Well:	North Alamito Unit 311H	Survey Calculation Method:	Minimum Curvature
Well Error:	0.00 ft	Output errors are at	2.00 sigma
Reference Wellbore	Original Hole	Database:	DT-Oct0825v17
Reference Design:	rev1	Offset TVD Reference:	Offset Datum

Reference Depths are relative to RKB=6946+23.5 @ 6969.50ft
 Offset Depths are relative to Offset Datum
 Central Meridian is -106.25000000

Coordinates are relative to: North Alamito Unit 311H
 Coordinate System is US State Plane 1983, New Mexico Central Zone
 Grid Convergence at Surface is: -0.780°

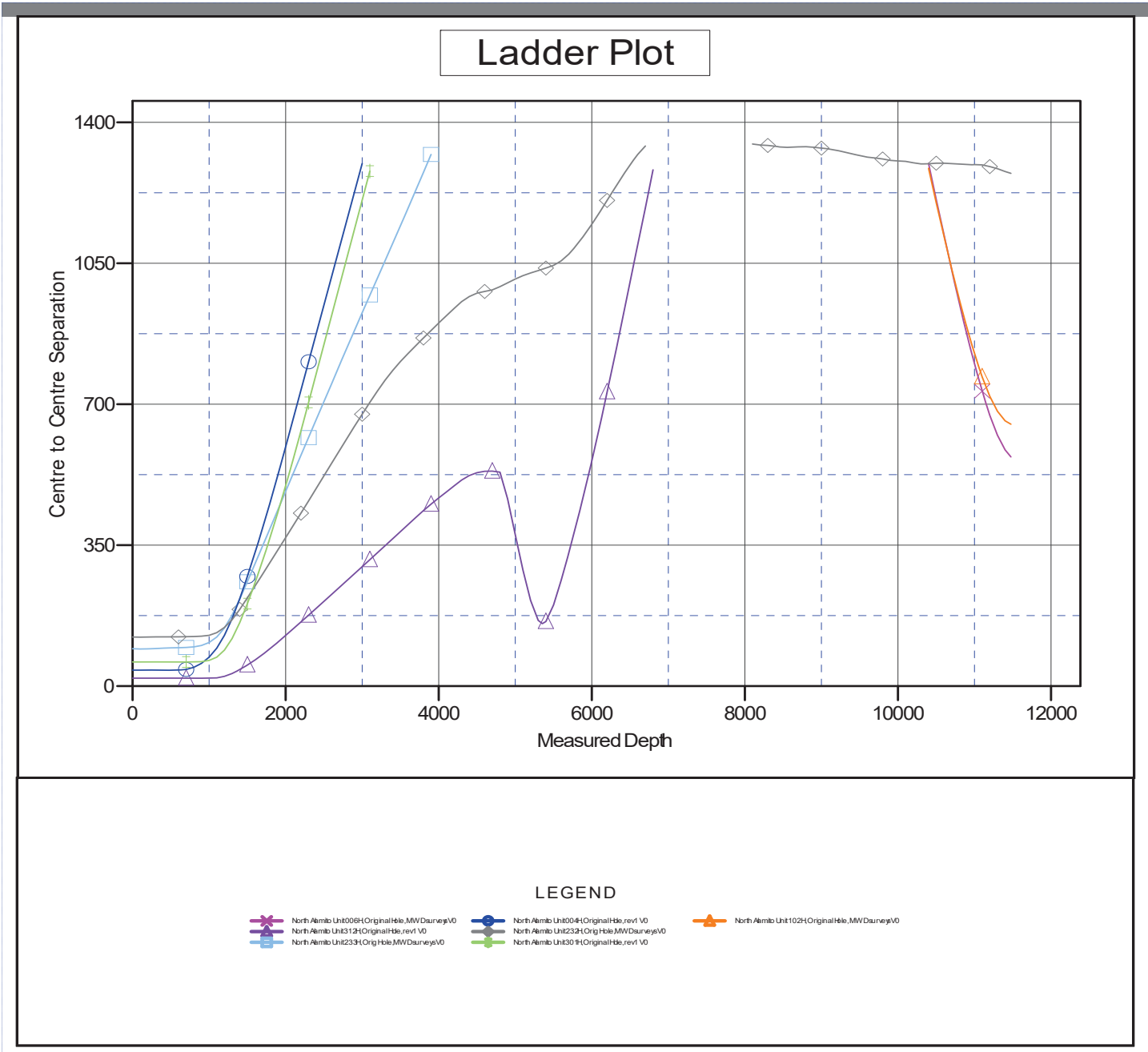

CC - Min centre to center distance or convergent point, SF - min separation factor, ES - min ellipse separation



Anticollision Report

Company:	Enduring Resources LLC	Local Co-ordinate Reference:	Well North Alamito Unit 311H
Project:	Sandoval County, New Mexico NAD83 NM C	TVD Reference:	RKB=6946+23.5 @ 6969.50ft
Reference Site:	Sec 28 T23N R07W North Alamito 4 301 311&312	MD Reference:	RKB=6946+23.5 @ 6969.50ft
Site Error:	0.00 ft	North Reference:	Grid
Reference Well:	North Alamito Unit 311H	Survey Calculation Method:	Minimum Curvature
Well Error:	0.00 ft	Output errors are at	2.00 sigma
Reference Wellbore	Original Hole	Database:	DT-Oct0825v17
Reference Design:	rev1	Offset TVD Reference:	Offset Datum

Reference Depths are relative to RKB=6946+23.5 @ 6969.50ft
 Offset Depths are relative to Offset Datum
 Central Meridian is -106.25000000

Coordinates are relative to: North Alamito Unit 311H
 Coordinate System is US State Plane 1983, New Mexico Central Zone
 Grid Convergence at Surface is: -0.780°

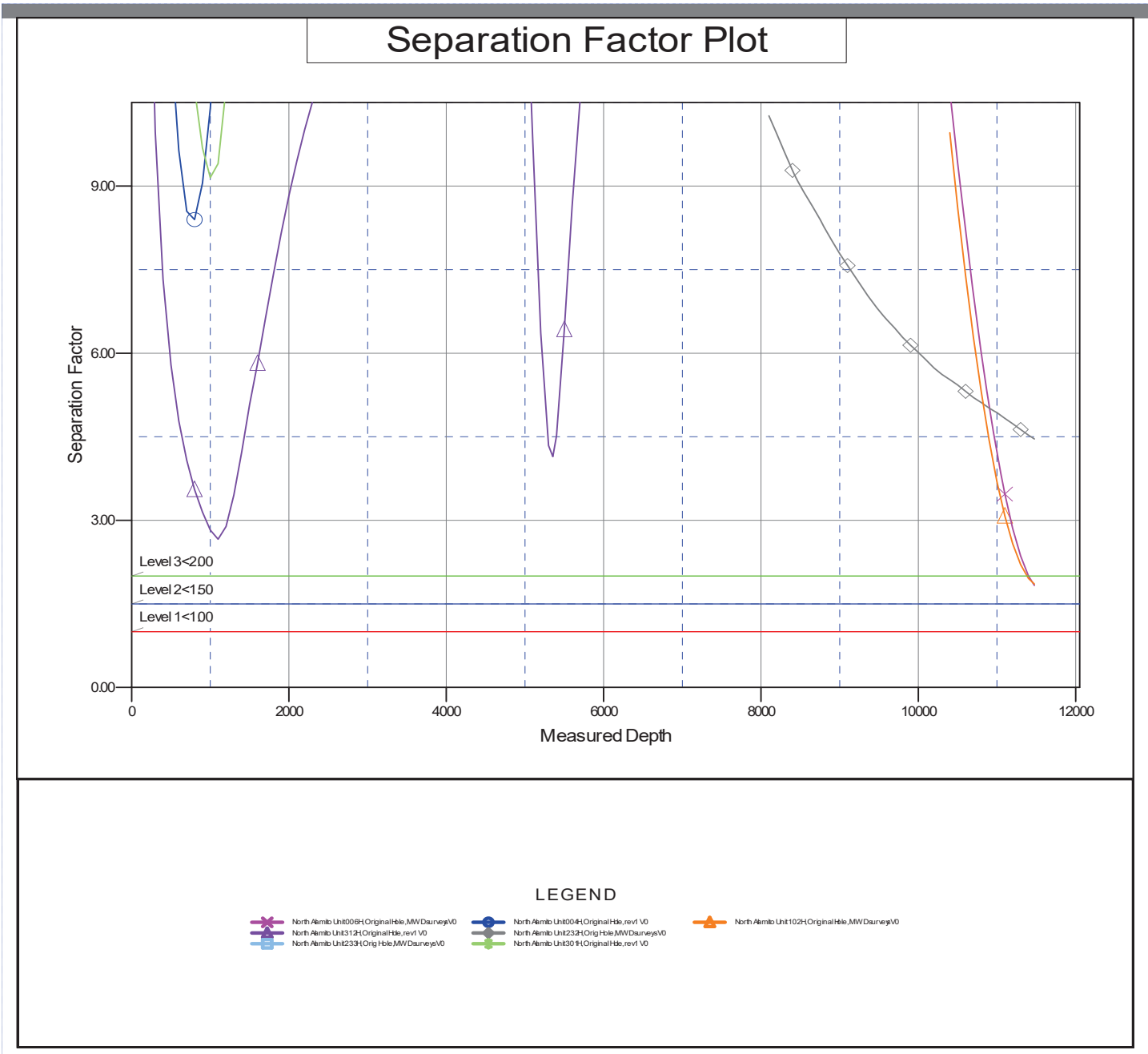

CC - Min centre to center distance or convergent point, SF - min separation factor, ES - min ellipse separation



Well: North Alamito Unit 311H
Site: North Alamito Unit (4, 301,311 & 312)
Project: Sandoval County, New Mexico NAD83 NmW
Design: rev0
Rig:

Section Details

Sec	MD	Inc	Azi	TVD	+N/-S	+E/-W	Dleg	TFace	Vsect	Annotation
1	0.00	0.00	0.000	0.00	0.00	0.00	0.00	0.000	0.00	
2	1000.00	0.00	0.000	1000.00	0.00	0.00	0.00	0.000	0.00	KOP Begin 3°/100' build
3	1395.33	11.86	186.597	1392.51	-40.50	-4.68	3.00	186.597	-23.94	Begin 11.86° tangent
4	4236.56	11.86	186.597	4173.09	-620.56	-71.77	0.00	0.000	-366.79	Begin 3°/100' drop
5	4631.89	0.00	0.000	4565.60	-661.06	-76.45	3.00	180.000	-390.73	Begin vertical hold
6	4781.89	0.00	0.000	4715.60	-661.06	-76.45	0.00	0.000	-390.73	Begin 10°/100' build
7	5481.89	70.00	312.552	5254.00	-406.11	-354.17	10.00	312.552	-13.74	
8	5683.32	90.14	312.552	5288.56	-272.62	-499.58	10.00	0.000	183.66	Begin 90.14° lateral
9	11508.97	90.14	312.552	5274.00	3667.01	-4791.12	0.00	0.000	6009.29	PBHL/TD

DESIGN TARGET DETAILS

Name	TVD	+N/-S	+E/-W	Northing	Easting	Latitude	Longitude
North Alamito 311H vert	4715.60	-661.06	-76.45	1889318.83	2800337.48	36.19208059	-107.57154414
North Alamito 311H LTP 439 FNL 419 FWL	5274.00	3667.01	-4791.12	1893646.89	2795622.82	36.20400400	-107.58748500
North Alamito 311H FTP 820 FSL 421 FEL	5289.00	-406.11	-354.17	1889573.78	2800059.76	36.19278300	-107.57248300
North Alamito 311H vs=0	5289.00	-396.82	-364.29	1889563.07	2800049.64	36.19280860	-107.57251722

CASING DETAILS

TVD	MD	Name
350.00	350.00	9-5/8" Surface Casing
5286.38	5631.89	7" Intermediate Casing

Geodetic System: US State Plane 1983
 Datum: North American Datum 1983
 Ellipsoid: GRS 1980
 Zone: New Mexico Western Zone
 System Datum: Mean Sea Level
 Depth Reference: RKB=6946+23.5 @ 6969.50ft

Surface location: Northing 1889979.89 Easting 2800413.93 Latitude 36.19389600 Longitude -107.57127900
 Total Corr (M=>G): To convert a Magnetic Direction to a Grid Direction, Add 8.156°

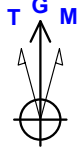

Azimuths to Grid North
 True North: -0.15°
 Magnetic North: 8.16°

Magnetic Field
 Strength: 48919.8nT
 Dip Angle: 62.66°
 Date: 4/10/2025
 Model: IGRF2020

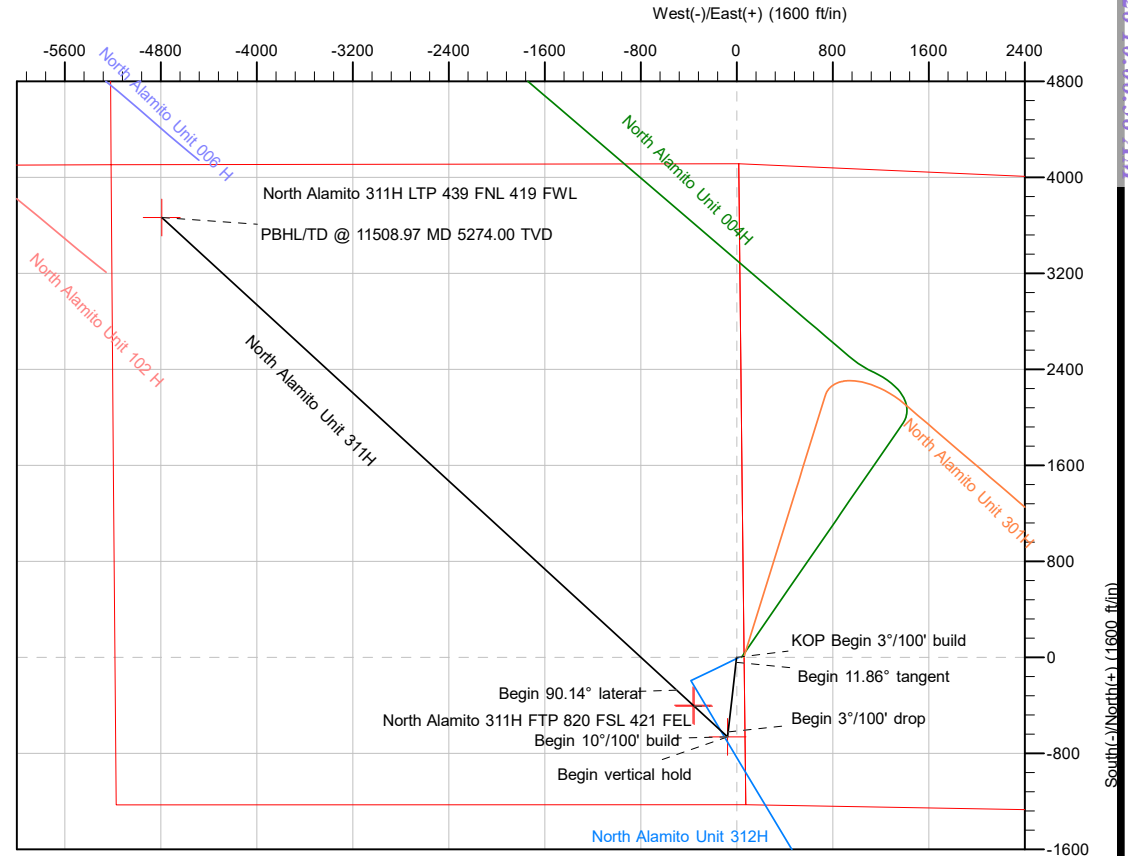
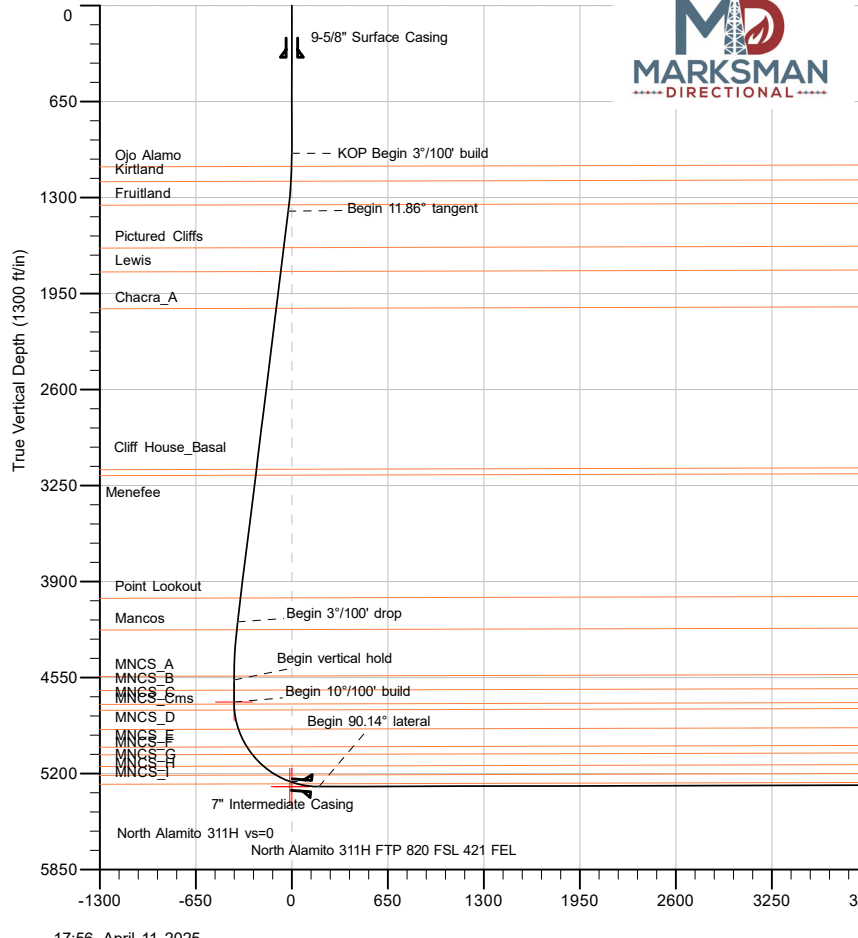

PBHL/TD @ 11508.97 MD 5274.00 TVD
 North Alamito 311H LTP 439 FNL 419 FWL



Well: North Alamito Unit 311H
Site: North Alamito Unit (4, 301,311 & 312)
Project: Sandoval County, New Mexico NAD83 NmW
Design: rev0
Rig:

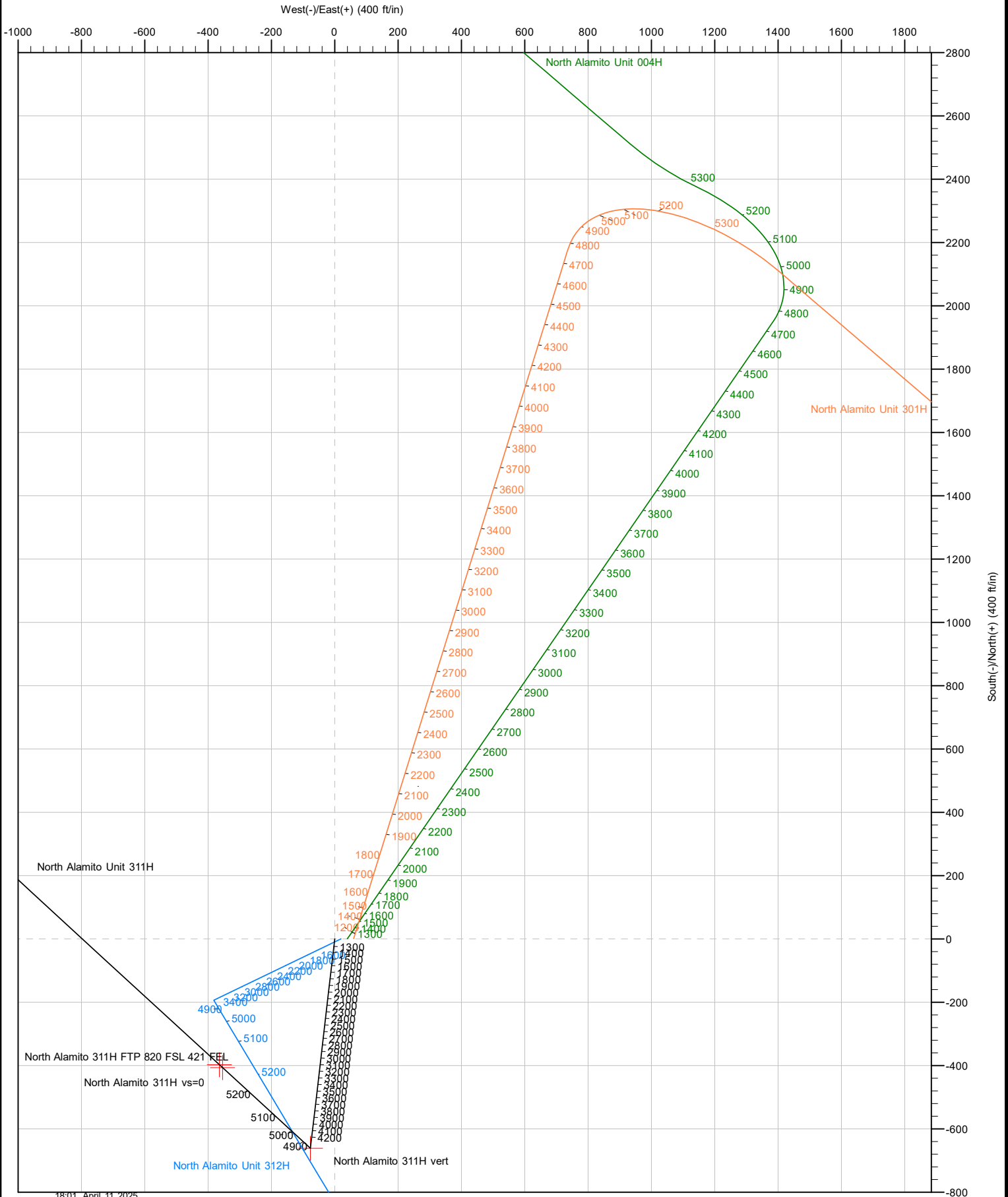

18:01, April 11 2025



Planning Report



Database:	DT_Jul1724_v17	Local Co-ordinate Reference:	Well North Alamito Unit 311H
Company:	Enduring Resources LLC	TVD Reference:	RKB=6946+23.5 @ 6969.50ft
Project:	Sandoval County, New Mexico NAD83 NmW	MD Reference:	RKB=6946+23.5 @ 6969.50ft
Site:	North Alamito Unit (4, 301,311 & 312)	North Reference:	Grid
Well:	North Alamito Unit 311H	Survey Calculation Method:	Minimum Curvature
Wellbore:	Original Hole		
Design:	rev0		

Project	Sandoval County, New Mexico NAD83 NmW		
Map System:	US State Plane 1983	System Datum:	Mean Sea Level
Geo Datum:	North American Datum 1983		
Map Zone:	New Mexico Western Zone		

Site	North Alamito Unit (4, 301,311 & 312)				
Site Position:		Northing:	1,889,980.73 usft	Latitude:	36.19389800
From:	Lat/Long	Easting:	2,800,453.76 usft	Longitude:	-107.57114400
Position Uncertainty:	0.00 ft	Slot Radius:	13-3/16 "		

Well	North Alamito Unit 311H, Surf loc: 1227 FSL 62 FEL Section 08-T23N-R07W					
Well Position	+N/-S	0.00 ft	Northing:	1,889,979.89 usft	Latitude:	36.19389600
	+E/-W	0.00 ft	Easting:	2,800,413.93 usft	Longitude:	-107.57127900
Position Uncertainty		0.00 ft	Wellhead Elevation:	ft	Ground Level:	6,946.00 ft
Grid Convergence:	0.155 °					

Wellbore	Original Hole				
Magnetics	Model Name	Sample Date	Declination (°)	Dip Angle (°)	Field Strength (nT)
	IGRF2020	4/10/2025	8.310	62.655	48,919.81123019

Design	rev0			
Audit Notes:				
Version:	Phase:	PLAN	Tie On Depth:	0.00
Vertical Section:	Depth From (TVD) (ft)	+N/-S (ft)	+E/-W (ft)	Direction (°)
	0.00	0.00	0.00	312.552

Plan Survey Tool Program	Date	4/11/2025		
Depth From (ft)	Depth To (ft)	Survey (Wellbore)	Tool Name	Remarks
1	0.00	11,508.97	rev0 (Original Hole)	MWD OWSG MWD - Standard



Planning Report



Database:	DT_Jul1724_v17	Local Co-ordinate Reference:	Well North Alamito Unit 311H
Company:	Enduring Resources LLC	TVD Reference:	RKB=6946+23.5 @ 6969.50ft
Project:	Sandoval County, New Mexico NAD83 NmW	MD Reference:	RKB=6946+23.5 @ 6969.50ft
Site:	North Alamito Unit (4, 301,311 & 312)	North Reference:	Grid
Well:	North Alamito Unit 311H	Survey Calculation Method:	Minimum Curvature
Wellbore:	Original Hole		
Design:	rev0		

Plan Sections										
Measured Depth (ft)	Inclination (°)	Azimuth (°)	Vertical Depth (ft)	+N/-S (ft)	+E/-W (ft)	Dogleg Rate (°/100ft)	Build Rate (°/100ft)	Turn Rate (°/100ft)	TFO (°)	Target
0.00	0.00	0.000	0.00	0.00	0.00	0.00	0.00	0.00	0.000	
1,000.00	0.00	0.000	1,000.00	0.00	0.00	0.00	0.00	0.00	0.000	
1,395.33	11.86	186.597	1,392.51	-40.50	-4.68	3.00	3.00	0.00	186.597	
4,236.56	11.86	186.597	4,173.09	-620.56	-71.77	0.00	0.00	0.00	0.000	
4,631.89	0.00	0.000	4,565.60	-661.06	-76.45	3.00	-3.00	0.00	180.000	
4,781.89	0.00	0.000	4,715.60	-661.06	-76.45	0.00	0.00	0.00	0.000	North Alamito 311H ve
5,481.89	70.00	312.552	5,254.00	-406.11	-354.17	10.00	10.00	0.00	312.552	
5,683.32	90.14	312.552	5,288.56	-272.62	-499.58	10.00	10.00	0.00	0.000	
11,508.97	90.14	312.552	5,274.00	3,667.01	-4,791.12	0.00	0.00	0.00	0.000	North Alamito 311H L



Planning Report



Database:	DT_Jul1724_v17	Local Co-ordinate Reference:	Well North Alamito Unit 311H
Company:	Enduring Resources LLC	TVD Reference:	RKB=6946+23.5 @ 6969.50ft
Project:	Sandoval County, New Mexico NAD83 NmW	MD Reference:	RKB=6946+23.5 @ 6969.50ft
Site:	North Alamito Unit (4, 301,311 & 312)	North Reference:	Grid
Well:	North Alamito Unit 311H	Survey Calculation Method:	Minimum Curvature
Wellbore:	Original Hole		
Design:	rev0		

Planned Survey										
Measured Depth (ft)	Inclination (°)	Azimuth (°)	Vertical Depth (ft)	+N/-S (ft)	+E/-W (ft)	Vertical Section (ft)	Dogleg Rate (°/100ft)	Build Rate (°/100ft)	Turn Rate (°/100ft)	
0.00	0.00	0.000	0.00	0.00	0.00	0.00	0.00	0.00	0.00	
100.00	0.00	0.000	100.00	0.00	0.00	0.00	0.00	0.00	0.00	
200.00	0.00	0.000	200.00	0.00	0.00	0.00	0.00	0.00	0.00	
300.00	0.00	0.000	300.00	0.00	0.00	0.00	0.00	0.00	0.00	
400.00	0.00	0.000	400.00	0.00	0.00	0.00	0.00	0.00	0.00	
500.00	0.00	0.000	500.00	0.00	0.00	0.00	0.00	0.00	0.00	
600.00	0.00	0.000	600.00	0.00	0.00	0.00	0.00	0.00	0.00	
700.00	0.00	0.000	700.00	0.00	0.00	0.00	0.00	0.00	0.00	
800.00	0.00	0.000	800.00	0.00	0.00	0.00	0.00	0.00	0.00	
900.00	0.00	0.000	900.00	0.00	0.00	0.00	0.00	0.00	0.00	
1,000.00	0.00	0.000	1,000.00	0.00	0.00	0.00	0.00	0.00	0.00	
KOP Begin 3°/100' build										
1,090.04	2.70	186.597	1,090.00	-2.11	-0.24	-1.25	3.00	3.00	0.00	
Ojo Alamo										
1,100.00	3.00	186.597	1,099.95	-2.60	-0.30	-1.54	3.00	3.00	0.00	
1,190.33	5.71	186.597	1,190.01	-9.41	-1.09	-5.56	3.00	3.00	0.00	
Kirtland										
1,200.00	6.00	186.597	1,199.63	-10.39	-1.20	-6.14	3.00	3.00	0.00	
1,300.00	9.00	186.597	1,298.77	-23.36	-2.70	-13.81	3.00	3.00	0.00	
1,352.04	10.56	186.597	1,350.05	-32.14	-3.72	-19.00	3.00	3.00	0.00	
Fruitland										
1,395.33	11.86	186.597	1,392.51	-40.50	-4.68	-23.94	3.00	3.00	0.00	
Begin 11.86° tangent										
1,400.00	11.86	186.597	1,397.08	-41.45	-4.79	-24.50	0.00	0.00	0.00	
1,500.00	11.86	186.597	1,494.95	-61.87	-7.16	-36.57	0.00	0.00	0.00	
1,600.00	11.86	186.597	1,592.81	-82.28	-9.52	-48.64	0.00	0.00	0.00	
1,648.35	11.86	186.597	1,640.13	-92.16	-10.66	-54.47	0.00	0.00	0.00	
Pictured Cliffs										
1,700.00	11.86	186.597	1,690.68	-102.70	-11.88	-60.70	0.00	0.00	0.00	
1,800.00	11.86	186.597	1,788.54	-123.12	-14.24	-72.77	0.00	0.00	0.00	
1,811.89	11.86	186.597	1,800.18	-125.54	-14.52	-74.20	0.00	0.00	0.00	
Lewis										
1,900.00	11.86	186.597	1,886.41	-143.53	-16.60	-84.84	0.00	0.00	0.00	
2,000.00	11.86	186.597	1,984.28	-163.95	-18.96	-96.90	0.00	0.00	0.00	
2,067.42	11.86	186.597	2,050.26	-177.71	-20.55	-105.04	0.00	0.00	0.00	
Chacra_A										
2,100.00	11.86	186.597	2,082.14	-184.36	-21.32	-108.97	0.00	0.00	0.00	
2,200.00	11.86	186.597	2,180.01	-204.78	-23.68	-121.04	0.00	0.00	0.00	
2,300.00	11.86	186.597	2,277.87	-225.20	-26.04	-133.11	0.00	0.00	0.00	
2,400.00	11.86	186.597	2,375.74	-245.61	-28.40	-145.17	0.00	0.00	0.00	
2,500.00	11.86	186.597	2,473.60	-266.03	-30.77	-157.24	0.00	0.00	0.00	
2,600.00	11.86	186.597	2,571.47	-286.44	-33.13	-169.31	0.00	0.00	0.00	
2,700.00	11.86	186.597	2,669.33	-306.86	-35.49	-181.37	0.00	0.00	0.00	
2,800.00	11.86	186.597	2,767.20	-327.28	-37.85	-193.44	0.00	0.00	0.00	
2,900.00	11.86	186.597	2,865.06	-347.69	-40.21	-205.51	0.00	0.00	0.00	
3,000.00	11.86	186.597	2,962.93	-368.11	-42.57	-217.58	0.00	0.00	0.00	
3,100.00	11.86	186.597	3,060.79	-388.52	-44.93	-229.64	0.00	0.00	0.00	
3,181.53	11.86	186.597	3,140.59	-405.17	-46.86	-239.48	0.00	0.00	0.00	
Cliff House_Basal										
3,200.00	11.86	186.597	3,158.66	-408.94	-47.29	-241.71	0.00	0.00	0.00	
3,222.42	11.86	186.597	3,180.60	-413.52	-47.82	-244.41	0.00	0.00	0.00	
Menefee										
3,300.00	11.86	186.597	3,256.52	-429.35	-49.65	-253.78	0.00	0.00	0.00	



Planning Report



Database:	DT_Jul1724_v17	Local Co-ordinate Reference:	Well North Alamito Unit 311H
Company:	Enduring Resources LLC	TVD Reference:	RKB=6946+23.5 @ 6969.50ft
Project:	Sandoval County, New Mexico NAD83 NmW	MD Reference:	RKB=6946+23.5 @ 6969.50ft
Site:	North Alamito Unit (4, 301,311 & 312)	North Reference:	Grid
Well:	North Alamito Unit 311H	Survey Calculation Method:	Minimum Curvature
Wellbore:	Original Hole		
Design:	rev0		

Planned Survey									
Measured Depth (ft)	Inclination (°)	Azimuth (°)	Vertical Depth (ft)	+N/-S (ft)	+E/-W (ft)	Vertical Section (ft)	Dogleg Rate (°/100ft)	Build Rate (°/100ft)	Turn Rate (°/100ft)
3,400.00	11.86	186.597	3,354.39	-449.77	-52.01	-265.84	0.00	0.00	0.00
3,500.00	11.86	186.597	3,452.25	-470.19	-54.38	-277.91	0.00	0.00	0.00
3,600.00	11.86	186.597	3,550.12	-490.60	-56.74	-289.98	0.00	0.00	0.00
3,700.00	11.86	186.597	3,647.99	-511.02	-59.10	-302.05	0.00	0.00	0.00
3,800.00	11.86	186.597	3,745.85	-531.43	-61.46	-314.11	0.00	0.00	0.00
3,900.00	11.86	186.597	3,843.72	-551.85	-63.82	-326.18	0.00	0.00	0.00
4,000.00	11.86	186.597	3,941.58	-572.27	-66.18	-338.25	0.00	0.00	0.00
4,070.78	11.86	186.597	4,010.85	-586.72	-67.85	-346.79	0.00	0.00	0.00
Point Lookout									
4,100.00	11.86	186.597	4,039.45	-592.68	-68.54	-350.31	0.00	0.00	0.00
4,200.00	11.86	186.597	4,137.31	-613.10	-70.90	-362.38	0.00	0.00	0.00
4,236.56	11.86	186.597	4,173.09	-620.56	-71.77	-366.79	0.00	0.00	0.00
Begin 3°/100' drop									
4,290.38	10.25	186.597	4,225.91	-630.81	-72.95	-372.85	3.00	-3.00	0.00
Mancos									
4,300.00	9.96	186.597	4,235.38	-632.49	-73.15	-373.84	3.00	-3.00	0.00
4,400.00	6.96	186.597	4,334.28	-647.09	-74.83	-382.47	3.00	-3.00	0.00
4,500.00	3.96	186.597	4,433.82	-656.54	-75.93	-388.06	3.00	-3.00	0.00
4,600.00	0.96	186.597	4,533.72	-660.80	-76.42	-390.57	3.00	-3.00	0.00
4,607.24	0.74	186.597	4,540.95	-660.90	-76.43	-390.64	3.00	-3.00	0.00
MNCS_A									
4,631.89	0.00	0.000	4,565.60	-661.06	-76.45	-390.73	3.00	-3.00	0.00
Begin vertical hold									
4,700.00	0.00	0.000	4,633.71	-661.06	-76.45	-390.73	0.00	0.00	0.00
4,702.24	0.00	0.000	4,635.95	-661.06	-76.45	-390.73	0.00	0.00	0.00
MNCS_B									
4,781.89	0.00	0.000	4,715.60	-661.06	-76.45	-390.73	0.00	0.00	0.00
Begin 10°/100' build									
4,797.24	1.54	312.552	4,730.95	-660.92	-76.60	-390.52	10.00	10.00	0.00
MNCS_C									
4,800.00	1.81	312.552	4,733.71	-660.87	-76.66	-390.44	10.00	10.00	0.00
4,837.32	5.54	312.552	4,770.95	-659.25	-78.42	-388.05	10.00	10.00	0.00
MNCS_Cms									
4,850.00	6.81	312.552	4,783.55	-658.33	-79.43	-386.69	10.00	10.00	0.00
4,900.00	11.81	312.552	4,832.88	-652.86	-85.39	-378.60	10.00	10.00	0.00
4,950.00	16.81	312.552	4,881.31	-644.50	-94.49	-366.24	10.00	10.00	0.00
4,970.56	18.87	312.552	4,900.88	-640.24	-99.13	-359.95	10.00	10.00	0.00
MNCS_D									
5,000.00	21.81	312.552	4,928.48	-633.32	-106.67	-349.71	10.00	10.00	0.00
5,050.00	26.81	312.552	4,974.04	-619.41	-121.83	-329.13	10.00	10.00	0.00
5,100.00	31.81	312.552	5,017.62	-602.86	-139.85	-304.66	10.00	10.00	0.00
5,103.68	32.18	312.552	5,020.74	-601.54	-141.29	-302.72	10.00	10.00	0.00
MNCS_E									
5,150.00	36.81	312.552	5,058.91	-583.80	-160.61	-276.49	10.00	10.00	0.00
5,164.82	38.29	312.552	5,070.65	-577.70	-167.26	-267.46	10.00	10.00	0.00
MNCS_F									
5,200.00	41.81	312.552	5,097.58	-562.39	-183.94	-244.82	10.00	10.00	0.00
5,250.00	46.81	312.552	5,133.35	-538.78	-209.66	-209.91	10.00	10.00	0.00
5,275.63	49.37	312.552	5,150.47	-525.88	-223.71	-190.83	10.00	10.00	0.00
MNCS_G									
5,300.00	51.81	312.552	5,165.93	-513.14	-237.58	-172.00	10.00	10.00	0.00
5,350.00	56.81	312.552	5,195.09	-485.69	-267.48	-131.41	10.00	10.00	0.00



Planning Report



Database:	DT_Jul1724_v17	Local Co-ordinate Reference:	Well North Alamito Unit 311H
Company:	Enduring Resources LLC	TVD Reference:	RKB=6946+23.5 @ 6969.50ft
Project:	Sandoval County, New Mexico NAD83 NmW	MD Reference:	RKB=6946+23.5 @ 6969.50ft
Site:	North Alamito Unit (4, 301,311 & 312)	North Reference:	Grid
Well:	North Alamito Unit 311H	Survey Calculation Method:	Minimum Curvature
Wellbore:	Original Hole		
Design:	rev0		

Planned Survey										
Measured Depth (ft)	Inclination (°)	Azimuth (°)	Vertical Depth (ft)	+N/-S (ft)	+E/-W (ft)	Vertical Section (ft)	Dogleg Rate (°/100ft)	Build Rate (°/100ft)	Turn Rate (°/100ft)	
5,378.83	59.69	312.552	5,210.26	-469.11	-285.54	-106.89	10.00	10.00	0.00	
MNCS_H										
5,400.00	61.81	312.552	5,220.60	-456.62	-299.15	-88.42	10.00	10.00	0.00	
5,450.00	66.81	312.552	5,242.27	-426.16	-332.33	-43.38	10.00	10.00	0.00	
5,481.89	70.00	312.552	5,254.00	-406.11	-354.17	-13.74	10.00	10.00	0.00	
5,500.00	71.81	312.552	5,259.93	-394.54	-366.78	3.38	10.00	10.00	0.00	
5,535.30	75.34	312.552	5,269.91	-371.64	-391.72	37.24	10.00	10.00	0.00	
MNCS_J										
5,550.00	76.81	312.552	5,273.45	-362.00	-402.23	51.50	10.00	10.00	0.00	
5,600.00	81.81	312.552	5,282.72	-328.78	-438.41	100.62	10.00	10.00	0.00	
5,650.00	86.81	312.552	5,287.67	-295.14	-475.05	150.36	10.00	10.00	0.00	
5,683.32	90.14	312.552	5,288.56	-272.62	-499.58	183.66	10.00	10.00	0.00	
Begin 90.14° lateral										
5,700.00	90.14	312.552	5,288.51	-261.34	-511.87	200.34	0.00	0.00	0.00	
5,800.00	90.14	312.552	5,288.26	-193.72	-585.54	300.34	0.00	0.00	0.00	
5,900.00	90.14	312.552	5,288.01	-126.09	-659.20	400.34	0.00	0.00	0.00	
6,000.00	90.14	312.552	5,287.76	-58.47	-732.87	500.34	0.00	0.00	0.00	
6,100.00	90.14	312.552	5,287.51	9.16	-806.54	600.34	0.00	0.00	0.00	
6,200.00	90.14	312.552	5,287.27	76.79	-880.20	700.34	0.00	0.00	0.00	
6,300.00	90.14	312.552	5,287.02	144.41	-953.87	800.34	0.00	0.00	0.00	
6,400.00	90.14	312.552	5,286.77	212.04	-1,027.53	900.34	0.00	0.00	0.00	
6,500.00	90.14	312.552	5,286.52	279.66	-1,101.20	1,000.34	0.00	0.00	0.00	
6,600.00	90.14	312.552	5,286.27	347.29	-1,174.87	1,100.34	0.00	0.00	0.00	
6,700.00	90.14	312.552	5,286.02	414.91	-1,248.53	1,200.34	0.00	0.00	0.00	
6,800.00	90.14	312.552	5,285.77	482.54	-1,322.20	1,300.34	0.00	0.00	0.00	
6,900.00	90.14	312.552	5,285.52	550.17	-1,395.87	1,400.34	0.00	0.00	0.00	
7,000.00	90.14	312.552	5,285.27	617.79	-1,469.53	1,500.34	0.00	0.00	0.00	
7,100.00	90.14	312.552	5,285.02	685.42	-1,543.20	1,600.34	0.00	0.00	0.00	
7,200.00	90.14	312.552	5,284.77	753.04	-1,616.86	1,700.34	0.00	0.00	0.00	
7,300.00	90.14	312.552	5,284.52	820.67	-1,690.53	1,800.34	0.00	0.00	0.00	
7,400.00	90.14	312.552	5,284.27	888.29	-1,764.20	1,900.34	0.00	0.00	0.00	
7,500.00	90.14	312.552	5,284.02	955.92	-1,837.86	2,000.34	0.00	0.00	0.00	
7,600.00	90.14	312.552	5,283.77	1,023.55	-1,911.53	2,100.34	0.00	0.00	0.00	
7,700.00	90.14	312.552	5,283.52	1,091.17	-1,985.19	2,200.34	0.00	0.00	0.00	
7,800.00	90.14	312.552	5,283.27	1,158.80	-2,058.86	2,300.34	0.00	0.00	0.00	
7,900.00	90.14	312.552	5,283.02	1,226.42	-2,132.53	2,400.34	0.00	0.00	0.00	
8,000.00	90.14	312.552	5,282.77	1,294.05	-2,206.19	2,500.34	0.00	0.00	0.00	
8,100.00	90.14	312.552	5,282.52	1,361.67	-2,279.86	2,600.33	0.00	0.00	0.00	
8,200.00	90.14	312.552	5,282.27	1,429.30	-2,353.53	2,700.33	0.00	0.00	0.00	
8,300.00	90.14	312.552	5,282.02	1,496.93	-2,427.19	2,800.33	0.00	0.00	0.00	
8,400.00	90.14	312.552	5,281.77	1,564.55	-2,500.86	2,900.33	0.00	0.00	0.00	
8,500.00	90.14	312.552	5,281.52	1,632.18	-2,574.52	3,000.33	0.00	0.00	0.00	
8,600.00	90.14	312.552	5,281.27	1,699.80	-2,648.19	3,100.33	0.00	0.00	0.00	
8,700.00	90.14	312.552	5,281.02	1,767.43	-2,721.86	3,200.33	0.00	0.00	0.00	
8,800.00	90.14	312.552	5,280.77	1,835.05	-2,795.52	3,300.33	0.00	0.00	0.00	
8,900.00	90.14	312.552	5,280.52	1,902.68	-2,869.19	3,400.33	0.00	0.00	0.00	
9,000.00	90.14	312.552	5,280.27	1,970.31	-2,942.86	3,500.33	0.00	0.00	0.00	
9,100.00	90.14	312.552	5,280.02	2,037.93	-3,016.52	3,600.33	0.00	0.00	0.00	
9,200.00	90.14	312.552	5,279.77	2,105.56	-3,090.19	3,700.33	0.00	0.00	0.00	
9,300.00	90.14	312.552	5,279.52	2,173.18	-3,163.85	3,800.33	0.00	0.00	0.00	
9,400.00	90.14	312.552	5,279.27	2,240.81	-3,237.52	3,900.33	0.00	0.00	0.00	
9,500.00	90.14	312.552	5,279.02	2,308.43	-3,311.19	4,000.33	0.00	0.00	0.00	
9,600.00	90.14	312.552	5,278.77	2,376.06	-3,384.85	4,100.33	0.00	0.00	0.00	



Planning Report



Database:	DT_Jul1724_v17	Local Co-ordinate Reference:	Well North Alamito Unit 311H
Company:	Enduring Resources LLC	TVD Reference:	RKB=6946+23.5 @ 6969.50ft
Project:	Sandoval County, New Mexico NAD83 NmW	MD Reference:	RKB=6946+23.5 @ 6969.50ft
Site:	North Alamito Unit (4, 301,311 & 312)	North Reference:	Grid
Well:	North Alamito Unit 311H	Survey Calculation Method:	Minimum Curvature
Wellbore:	Original Hole		
Design:	rev0		

Planned Survey										
Measured Depth (ft)	Inclination (°)	Azimuth (°)	Vertical Depth (ft)	+N/-S (ft)	+E/-W (ft)	Vertical Section (ft)	Dogleg Rate (°/100ft)	Build Rate (°/100ft)	Turn Rate (°/100ft)	
9,700.00	90.14	312.552	5,278.52	2,443.69	-3,458.52	4,200.33	0.00	0.00	0.00	
9,800.00	90.14	312.552	5,278.27	2,511.31	-3,532.18	4,300.33	0.00	0.00	0.00	
9,900.00	90.14	312.552	5,278.02	2,578.94	-3,605.85	4,400.33	0.00	0.00	0.00	
10,000.00	90.14	312.552	5,277.77	2,646.56	-3,679.52	4,500.33	0.00	0.00	0.00	
10,100.00	90.14	312.552	5,277.52	2,714.19	-3,753.18	4,600.33	0.00	0.00	0.00	
10,200.00	90.14	312.552	5,277.27	2,781.81	-3,826.85	4,700.33	0.00	0.00	0.00	
10,300.00	90.14	312.552	5,277.02	2,849.44	-3,900.52	4,800.33	0.00	0.00	0.00	
10,400.00	90.14	312.552	5,276.77	2,917.07	-3,974.18	4,900.33	0.00	0.00	0.00	
10,500.00	90.14	312.552	5,276.52	2,984.69	-4,047.85	5,000.33	0.00	0.00	0.00	
10,600.00	90.14	312.552	5,276.27	3,052.32	-4,121.51	5,100.33	0.00	0.00	0.00	
10,700.00	90.14	312.552	5,276.02	3,119.94	-4,195.18	5,200.33	0.00	0.00	0.00	
10,800.00	90.14	312.552	5,275.77	3,187.57	-4,268.85	5,300.33	0.00	0.00	0.00	
10,900.00	90.14	312.552	5,275.52	3,255.19	-4,342.51	5,400.33	0.00	0.00	0.00	
11,000.00	90.14	312.552	5,275.27	3,322.82	-4,416.18	5,500.33	0.00	0.00	0.00	
11,100.00	90.14	312.552	5,275.02	3,390.45	-4,489.84	5,600.33	0.00	0.00	0.00	
11,200.00	90.14	312.552	5,274.77	3,458.07	-4,563.51	5,700.33	0.00	0.00	0.00	
11,300.00	90.14	312.552	5,274.52	3,525.70	-4,637.18	5,800.32	0.00	0.00	0.00	
11,400.00	90.14	312.552	5,274.27	3,593.32	-4,710.84	5,900.32	0.00	0.00	0.00	
11,508.97	90.14	312.552	5,274.00	3,667.01	-4,791.12	6,009.29	0.00	0.00	0.00	
PBHL/TD @ 11508.97 MD 5274.00 TVD										

Formations						
Measured Depth (ft)	Vertical Depth (ft)	Name	Lithology	Dip (°)	Dip Direction (°)	
1,090.04	1,090.00	Ojo Alamo		-0.140	312.552	
1,190.33	1,190.01	Kirtland		-0.140	312.552	
1,352.04	1,350.05	Fruitland		-0.140	312.552	
1,648.35	1,640.13	Pictured Cliffs		-0.140	312.552	
1,811.89	1,800.18	Lewis		-0.140	312.552	
2,067.42	2,050.26	Chacra_A		-0.140	312.552	
3,181.53	3,140.59	Cliff House_Basal		-0.140	312.552	
3,222.42	3,180.60	Menefee		-0.140	312.552	
4,070.78	4,010.85	Point Lookout		-0.140	312.552	
4,290.38	4,225.91	Mancos		-0.140	312.552	
4,607.24	4,540.95	MNCS_A		-0.140	312.552	
4,702.24	4,635.95	MNCS_B		-0.140	312.552	
4,797.24	4,730.95	MNCS_C		-0.140	312.552	
4,837.32	4,770.95	MNCS_Cms		-0.140	312.552	
4,970.56	4,900.88	MNCS_D		-0.140	312.552	
5,103.68	5,020.74	MNCS_E		-0.140	312.552	
5,164.82	5,070.65	MNCS_F		-0.140	312.552	
5,275.63	5,150.47	MNCS_G		-0.140	312.552	
5,378.83	5,210.26	MNCS_H		-0.140	312.552	
5,535.30	5,269.91	MNCS_I		-0.140	312.552	



Planning Report



Database:	DT_Jul1724_v17	Local Co-ordinate Reference:	Well North Alamito Unit 311H
Company:	Enduring Resources LLC	TVD Reference:	RKB=6946+23.5 @ 6969.50ft
Project:	Sandoval County, New Mexico NAD83 NmW	MD Reference:	RKB=6946+23.5 @ 6969.50ft
Site:	North Alamito Unit (4, 301,311 & 312)	North Reference:	Grid
Well:	North Alamito Unit 311H	Survey Calculation Method:	Minimum Curvature
Wellbore:	Original Hole		
Design:	rev0		

Plan Annotations					
Measured Depth (ft)	Vertical Depth (ft)	Local Coordinates		Comment	
		+N/-S (ft)	+E/-W (ft)		
1,000.00	1,000.00	0.00	0.00	KOP Begin 3°/100' build	
1,395.33	1,392.51	-40.50	-4.68	Begin 11.86° tangent	
4,236.56	4,173.09	-620.56	-71.77	Begin 3°/100' drop	
4,631.89	4,565.60	-661.06	-76.45	Begin vertical hold	
4,781.89	4,715.60	-661.06	-76.45	Begin 10°/100' build	
5,481.89	5,254.00	-406.11	-354.17		
5,683.32	5,288.56	-272.62	-499.58	Begin 90.14° lateral	
11,508.97	5,274.00	3,667.01	-4,791.12	PBHL/TD @ 11508.97 MD 5274.00 TVD	



Planning Report - Geographic



Database:	DT_Jul1724_v17	Local Co-ordinate Reference:	Well North Alamito Unit 311H
Company:	Enduring Resources LLC	TVD Reference:	RKB=6946+23.5 @ 6969.50ft
Project:	Sandoval County, New Mexico NAD83 NmW	MD Reference:	RKB=6946+23.5 @ 6969.50ft
Site:	North Alamito Unit (4, 301,311 & 312)	North Reference:	Grid
Well:	North Alamito Unit 311H	Survey Calculation Method:	Minimum Curvature
Wellbore:	Original Hole		
Design:	rev0		

Project	Sandoval County, New Mexico NAD83 NmW		
Map System:	US State Plane 1983	System Datum:	Mean Sea Level
Geo Datum:	North American Datum 1983		
Map Zone:	New Mexico Western Zone		

Site	North Alamito Unit (4, 301,311 & 312)				
Site Position:		Northing:	1,889,980.73 usft	Latitude:	36.19389800
From:	Lat/Long	Easting:	2,800,453.76 usft	Longitude:	-107.57114400
Position Uncertainty:	0.00 ft	Slot Radius:	13-3/16 "		

Well	North Alamito Unit 311H, Surf loc: 1227 FSL 62 FEL Section 08-T23N-R07W					
Well Position	+N/-S	0.00 ft	Northing:	1,889,979.89 usft	Latitude:	36.19389600
	+E/-W	0.00 ft	Easting:	2,800,413.93 usft	Longitude:	-107.57127900
Position Uncertainty	0.00 ft		Wellhead Elevation:	ft	Ground Level:	6,946.00 ft
Grid Convergence:	0.155 °					

Wellbore	Original Hole				
Magnetics	Model Name	Sample Date	Declination (°)	Dip Angle (°)	Field Strength (nT)
	IGRF2020	4/10/2025	8.310	62.655	48,919.81123019

Design	rev0			
Audit Notes:				
Version:	Phase:	PLAN	Tie On Depth:	0.00
Vertical Section:	Depth From (TVD) (ft)	+N/-S (ft)	+E/-W (ft)	Direction (°)
	0.00	0.00	0.00	312.552

Plan Survey Tool Program	Date	4/11/2025		
Depth From (ft)	Depth To (ft)	Survey (Wellbore)	Tool Name	Remarks
1	0.00	11,508.97 rev0 (Original Hole)	MWD	OWSG MWD - Standard



Planning Report - Geographic



Database:	DT_Jul1724_v17	Local Co-ordinate Reference:	Well North Alamito Unit 311H
Company:	Enduring Resources LLC	TVD Reference:	RKB=6946+23.5 @ 6969.50ft
Project:	Sandoval County, New Mexico NAD83 NmW	MD Reference:	RKB=6946+23.5 @ 6969.50ft
Site:	North Alamito Unit (4, 301,311 & 312)	North Reference:	Grid
Well:	North Alamito Unit 311H	Survey Calculation Method:	Minimum Curvature
Wellbore:	Original Hole		
Design:	rev0		

Plan Sections										
Measured Depth (ft)	Inclination (°)	Azimuth (°)	Vertical Depth (ft)	+N/-S (ft)	+E/-W (ft)	Dogleg Rate (°/100ft)	Build Rate (°/100ft)	Turn Rate (°/100ft)	TFO (°)	Target
0.00	0.00	0.000	0.00	0.00	0.00	0.00	0.00	0.00	0.000	
1,000.00	0.00	0.000	1,000.00	0.00	0.00	0.00	0.00	0.00	0.000	
1,395.33	11.86	186.597	1,392.51	-40.50	-4.68	3.00	3.00	0.00	186.597	
4,236.56	11.86	186.597	4,173.09	-620.56	-71.77	0.00	0.00	0.00	0.000	
4,631.89	0.00	0.000	4,565.60	-661.06	-76.45	3.00	-3.00	0.00	180.000	
4,781.89	0.00	0.000	4,715.60	-661.06	-76.45	0.00	0.00	0.00	0.000	North Alamito 311H ve
5,481.89	70.00	312.552	5,254.00	-406.11	-354.17	10.00	10.00	0.00	312.552	
5,683.32	90.14	312.552	5,288.56	-272.62	-499.58	10.00	10.00	0.00	0.000	
11,508.97	90.14	312.552	5,274.00	3,667.01	-4,791.12	0.00	0.00	0.00	0.000	North Alamito 311H L



Planning Report - Geographic



Database:	DT_Jul1724_v17	Local Co-ordinate Reference:	Well North Alamito Unit 311H
Company:	Enduring Resources LLC	TVD Reference:	RKB=6946+23.5 @ 6969.50ft
Project:	Sandoval County, New Mexico NAD83 NmW	MD Reference:	RKB=6946+23.5 @ 6969.50ft
Site:	North Alamito Unit (4, 301,311 & 312)	North Reference:	Grid
Well:	North Alamito Unit 311H	Survey Calculation Method:	Minimum Curvature
Wellbore:	Original Hole		
Design:	rev0		

Planned Survey										
Measured Depth (ft)	Inclination (°)	Azimuth (°)	Vertical Depth (ft)	+N/-S (ft)	+E/-W (ft)	Map Northing (usft)	Map Easting (usft)	Latitude	Longitude	
0.00	0.00	0.000	0.00	0.00	0.00	1,889,979.89	2,800,413.93	36.19389600	-107.57127900	
100.00	0.00	0.000	100.00	0.00	0.00	1,889,979.89	2,800,413.93	36.19389600	-107.57127900	
200.00	0.00	0.000	200.00	0.00	0.00	1,889,979.89	2,800,413.93	36.19389600	-107.57127900	
300.00	0.00	0.000	300.00	0.00	0.00	1,889,979.89	2,800,413.93	36.19389600	-107.57127900	
400.00	0.00	0.000	400.00	0.00	0.00	1,889,979.89	2,800,413.93	36.19389600	-107.57127900	
500.00	0.00	0.000	500.00	0.00	0.00	1,889,979.89	2,800,413.93	36.19389600	-107.57127900	
600.00	0.00	0.000	600.00	0.00	0.00	1,889,979.89	2,800,413.93	36.19389600	-107.57127900	
700.00	0.00	0.000	700.00	0.00	0.00	1,889,979.89	2,800,413.93	36.19389600	-107.57127900	
800.00	0.00	0.000	800.00	0.00	0.00	1,889,979.89	2,800,413.93	36.19389600	-107.57127900	
900.00	0.00	0.000	900.00	0.00	0.00	1,889,979.89	2,800,413.93	36.19389600	-107.57127900	
1,000.00	0.00	0.000	1,000.00	0.00	0.00	1,889,979.89	2,800,413.93	36.19389600	-107.57127900	
KOP Begin 3°/100' build										
1,090.04	2.70	186.597	1,090.00	-2.11	-0.24	1,889,977.78	2,800,413.68	36.19389021	-107.57127985	
Ojo Alamo										
1,100.00	3.00	186.597	1,099.95	-2.60	-0.30	1,889,977.29	2,800,413.63	36.19388886	-107.57128005	
1,190.33	5.71	186.597	1,190.01	-9.41	-1.09	1,889,970.48	2,800,412.84	36.19387015	-107.57128278	
Kirtland										
1,200.00	6.00	186.597	1,199.63	-10.39	-1.20	1,889,969.50	2,800,412.73	36.19386746	-107.57128317	
1,300.00	9.00	186.597	1,298.77	-23.36	-2.70	1,889,956.53	2,800,411.23	36.19383185	-107.57128837	
1,352.04	10.56	186.597	1,350.05	-32.14	-3.72	1,889,947.75	2,800,410.21	36.19380774	-107.57129189	
Fruitland										
1,395.33	11.86	186.597	1,392.51	-40.50	-4.68	1,889,939.39	2,800,409.24	36.19378478	-107.57129525	
Begin 11.86° tangent										
1,400.00	11.86	186.597	1,397.08	-41.45	-4.79	1,889,938.44	2,800,409.13	36.19378216	-107.57129563	
1,500.00	11.86	186.597	1,494.95	-61.87	-7.16	1,889,918.02	2,800,406.77	36.19372609	-107.57130382	
1,600.00	11.86	186.597	1,592.81	-82.28	-9.52	1,889,897.61	2,800,404.41	36.19367003	-107.57131201	
1,648.35	11.86	186.597	1,640.13	-92.16	-10.66	1,889,887.73	2,800,403.27	36.19364292	-107.57131597	
Pictured Cliffs										
1,700.00	11.86	186.597	1,690.68	-102.70	-11.88	1,889,877.19	2,800,402.05	36.19361396	-107.57132020	
1,800.00	11.86	186.597	1,788.54	-123.12	-14.24	1,889,856.77	2,800,399.69	36.19355790	-107.57132838	
1,811.89	11.86	186.597	1,800.18	-125.54	-14.52	1,889,854.35	2,800,399.41	36.19355123	-107.57132936	
Lewis										
1,900.00	11.86	186.597	1,886.41	-143.53	-16.60	1,889,836.36	2,800,397.33	36.19350183	-107.57133657	
2,000.00	11.86	186.597	1,984.28	-163.95	-18.96	1,889,815.94	2,800,394.97	36.19344576	-107.57134476	
2,067.42	11.86	186.597	2,050.26	-177.71	-20.55	1,889,802.18	2,800,393.38	36.19340796	-107.57135028	
Chacra_A										
2,100.00	11.86	186.597	2,082.14	-184.36	-21.32	1,889,795.53	2,800,392.61	36.19338970	-107.57135295	
2,200.00	11.86	186.597	2,180.01	-204.78	-23.68	1,889,775.11	2,800,390.25	36.19333363	-107.57136114	
2,300.00	11.86	186.597	2,277.87	-225.20	-26.04	1,889,754.70	2,800,387.89	36.19327756	-107.57136933	
2,400.00	11.86	186.597	2,375.74	-245.61	-28.40	1,889,734.28	2,800,385.52	36.19322150	-107.57137752	
2,500.00	11.86	186.597	2,473.60	-266.03	-30.77	1,889,713.86	2,800,383.16	36.19316543	-107.57138570	
2,600.00	11.86	186.597	2,571.47	-286.44	-33.13	1,889,693.45	2,800,380.80	36.19310937	-107.57139389	
2,700.00	11.86	186.597	2,669.33	-306.86	-35.49	1,889,673.03	2,800,378.44	36.19305330	-107.57140208	
2,800.00	11.86	186.597	2,767.20	-327.28	-37.85	1,889,652.62	2,800,376.08	36.19299723	-107.57141027	
2,900.00	11.86	186.597	2,865.06	-347.69	-40.21	1,889,632.20	2,800,373.72	36.19294117	-107.57141846	
3,000.00	11.86	186.597	2,962.93	-368.11	-42.57	1,889,611.78	2,800,371.36	36.19288510	-107.57142665	
3,100.00	11.86	186.597	3,060.79	-388.52	-44.93	1,889,591.37	2,800,369.00	36.19282903	-107.57143484	
3,181.53	11.86	186.597	3,140.59	-405.17	-46.86	1,889,574.72	2,800,367.07	36.19278332	-107.57144151	
Cliff House_Basal										
3,200.00	11.86	186.597	3,158.66	-408.94	-47.29	1,889,570.95	2,800,366.64	36.19277297	-107.57144302	
3,222.42	11.86	186.597	3,180.60	-413.52	-47.82	1,889,566.38	2,800,366.11	36.19276040	-107.57144486	
Menefee										
3,300.00	11.86	186.597	3,256.52	-429.35	-49.65	1,889,550.54	2,800,364.27	36.19271690	-107.57145121	



Planning Report - Geographic



Database:	DT_Jul1724_v17	Local Co-ordinate Reference:	Well North Alamito Unit 311H
Company:	Enduring Resources LLC	TVD Reference:	RKB=6946+23.5 @ 6969.50ft
Project:	Sandoval County, New Mexico NAD83 NmW	MD Reference:	RKB=6946+23.5 @ 6969.50ft
Site:	North Alamito Unit (4, 301,311 & 312)	North Reference:	Grid
Well:	North Alamito Unit 311H	Survey Calculation Method:	Minimum Curvature
Wellbore:	Original Hole		
Design:	rev0		

Planned Survey										
Measured Depth (ft)	Inclination (°)	Azimuth (°)	Vertical Depth (ft)	+N/-S (ft)	+E/-W (ft)	Map Northing (usft)	Map Easting (usft)	Latitude	Longitude	
3,400.00	11.86	186.597	3,354.39	-449.77	-52.01	1,889,530.12	2,800,361.91	36.19266083	-107.57145940	
3,500.00	11.86	186.597	3,452.25	-470.19	-54.38	1,889,509.71	2,800,359.55	36.19260477	-107.57146759	
3,600.00	11.86	186.597	3,550.12	-490.60	-56.74	1,889,489.29	2,800,357.19	36.19254870	-107.57147578	
3,700.00	11.86	186.597	3,647.99	-511.02	-59.10	1,889,468.87	2,800,354.83	36.19249264	-107.57148397	
3,800.00	11.86	186.597	3,745.85	-531.43	-61.46	1,889,448.46	2,800,352.47	36.19243657	-107.57149215	
3,900.00	11.86	186.597	3,843.72	-551.85	-63.82	1,889,428.04	2,800,350.11	36.19238050	-107.57150034	
4,000.00	11.86	186.597	3,941.58	-572.27	-66.18	1,889,407.63	2,800,347.75	36.19232444	-107.57150853	
4,070.78	11.86	186.597	4,010.85	-586.72	-67.85	1,889,393.18	2,800,346.08	36.19228475	-107.57151433	
Point Lookout										
4,100.00	11.86	186.597	4,039.45	-592.68	-68.54	1,889,387.21	2,800,345.39	36.19226837	-107.57151672	
4,200.00	11.86	186.597	4,137.31	-613.10	-70.90	1,889,366.79	2,800,343.03	36.19221230	-107.57152491	
4,236.56	11.86	186.597	4,173.09	-620.56	-71.77	1,889,359.33	2,800,342.16	36.19219181	-107.57152790	
Begin 3°/100' drop										
4,290.38	10.25	186.597	4,225.91	-630.81	-72.95	1,889,349.08	2,800,340.98	36.19216366	-107.57153201	
Mancos										
4,300.00	9.96	186.597	4,235.38	-632.49	-73.15	1,889,347.41	2,800,340.78	36.19215906	-107.57153268	
4,400.00	6.96	186.597	4,334.28	-647.09	-74.83	1,889,332.80	2,800,339.09	36.19211894	-107.57153854	
4,500.00	3.96	186.597	4,433.82	-656.54	-75.93	1,889,323.35	2,800,338.00	36.19209301	-107.57154233	
4,600.00	0.96	186.597	4,533.72	-660.80	-76.42	1,889,319.10	2,800,337.51	36.19208131	-107.57154404	
4,607.24	0.74	186.597	4,540.95	-660.90	-76.43	1,889,318.99	2,800,337.50	36.19208102	-107.57154408	
MNCS_A										
4,631.89	0.00	0.000	4,565.60	-661.06	-76.45	1,889,318.83	2,800,337.48	36.19208059	-107.57154414	
Begin vertical hold										
4,700.00	0.00	0.000	4,633.71	-661.06	-76.45	1,889,318.83	2,800,337.48	36.19208059	-107.57154414	
4,702.24	0.00	0.000	4,635.95	-661.06	-76.45	1,889,318.83	2,800,337.48	36.19208059	-107.57154414	
MNCS_B										
4,781.89	0.00	0.000	4,715.60	-661.06	-76.45	1,889,318.83	2,800,337.48	36.19208059	-107.57154414	
Begin 10°/100' build										
4,797.24	1.54	312.552	4,730.95	-660.92	-76.60	1,889,318.97	2,800,337.33	36.19208097	-107.57154466	
MNCS_C										
4,800.00	1.81	312.552	4,733.71	-660.87	-76.66	1,889,319.03	2,800,337.27	36.19208112	-107.57154486	
4,837.32	5.54	312.552	4,770.95	-659.25	-78.42	1,889,320.64	2,800,335.50	36.19208558	-107.57155082	
MNCS_Cms										
4,850.00	6.81	312.552	4,783.55	-658.33	-79.43	1,889,321.57	2,800,334.50	36.19208812	-107.57155421	
4,900.00	11.81	312.552	4,832.88	-652.86	-85.39	1,889,327.04	2,800,328.54	36.19210319	-107.57157436	
4,950.00	16.81	312.552	4,881.31	-644.50	-94.49	1,889,335.39	2,800,319.44	36.19212621	-107.57160513	
4,970.56	18.87	312.552	4,900.88	-640.24	-99.13	1,889,339.65	2,800,314.80	36.19213794	-107.57162081	
MNCS_D										
5,000.00	21.81	312.552	4,928.48	-633.32	-106.67	1,889,346.57	2,800,307.26	36.19215701	-107.57164629	
5,050.00	26.81	312.552	4,974.04	-619.41	-121.83	1,889,360.49	2,800,292.10	36.19219535	-107.57169754	
5,100.00	31.81	312.552	5,017.62	-602.86	-139.85	1,889,377.03	2,800,274.08	36.19224094	-107.57175848	
5,103.68	32.18	312.552	5,020.74	-601.54	-141.29	1,889,378.35	2,800,272.64	36.19224457	-107.57176333	
MNCS_E										
5,150.00	36.81	312.552	5,058.91	-583.80	-160.61	1,889,396.09	2,800,253.32	36.19229344	-107.57182865	
5,164.82	38.29	312.552	5,070.65	-577.70	-167.26	1,889,402.20	2,800,246.67	36.19231027	-107.57185114	
MNCS_F										
5,200.00	41.81	312.552	5,097.58	-562.39	-183.94	1,889,417.50	2,800,229.99	36.19235244	-107.57190751	
5,250.00	46.81	312.552	5,133.35	-538.78	-209.66	1,889,441.12	2,800,204.27	36.19241750	-107.57199447	
5,275.63	49.37	312.552	5,150.47	-525.88	-223.71	1,889,454.02	2,800,190.22	36.19245304	-107.57204197	
MNCS_G										
5,300.00	51.81	312.552	5,165.93	-513.14	-237.58	1,889,466.75	2,800,176.35	36.19248811	-107.57208886	
5,350.00	56.81	312.552	5,195.09	-485.69	-267.48	1,889,494.20	2,800,146.45	36.19256375	-107.57218996	



Planning Report - Geographic



Database:	DT_Jul1724_v17	Local Co-ordinate Reference:	Well North Alamito Unit 311H
Company:	Enduring Resources LLC	TVD Reference:	RKB=6946+23.5 @ 6969.50ft
Project:	Sandoval County, New Mexico NAD83 NmW	MD Reference:	RKB=6946+23.5 @ 6969.50ft
Site:	North Alamito Unit (4, 301,311 & 312)	North Reference:	Grid
Well:	North Alamito Unit 311H	Survey Calculation Method:	Minimum Curvature
Wellbore:	Original Hole		
Design:	rev0		

Planned Survey										
Measured Depth (ft)	Inclination (°)	Azimuth (°)	Vertical Depth (ft)	+N/-S (ft)	+E/-W (ft)	Map Northing (usft)	Map Easting (usft)	Latitude	Longitude	
5,378.83	59.69	312.552	5,210.26	-469.11	-285.54	1,889,510.78	2,800,128.39	36.19260943	-107.57225101	
MNCS_H										
5,400.00	61.81	312.552	5,220.60	-456.62	-299.15	1,889,523.27	2,800,114.78	36.19264384	-107.57229701	
5,450.00	66.81	312.552	5,242.27	-426.16	-332.33	1,889,553.73	2,800,081.60	36.19272777	-107.57240918	
5,481.89	70.00	312.552	5,254.00	-406.11	-354.17	1,889,573.78	2,800,059.76	36.19278300	-107.57248301	
5,500.00	71.81	312.552	5,259.93	-394.54	-366.78	1,889,585.35	2,800,047.15	36.19281489	-107.57252564	
5,535.30	75.34	312.552	5,269.91	-371.64	-391.72	1,889,608.25	2,800,022.21	36.19287797	-107.57260995	
MNCS_I										
5,550.00	76.81	312.552	5,273.45	-362.00	-402.23	1,889,617.90	2,800,011.70	36.19290455	-107.57264548	
5,600.00	81.81	312.552	5,282.72	-328.78	-438.41	1,889,651.11	2,799,975.52	36.19299606	-107.57276780	
5,650.00	86.81	312.552	5,287.67	-295.14	-475.05	1,889,684.75	2,799,938.88	36.19308873	-107.57289167	
5,683.32	90.14	312.552	5,288.56	-272.62	-499.58	1,889,707.27	2,799,914.35	36.19315078	-107.57297461	
Begin 90.14° lateral										
5,700.00	90.14	312.552	5,288.51	-261.34	-511.87	1,889,718.55	2,799,902.06	36.19318186	-107.57301615	
5,800.00	90.14	312.552	5,288.26	-193.72	-585.54	1,889,786.17	2,799,828.39	36.19336817	-107.57326520	
5,900.00	90.14	312.552	5,288.01	-126.09	-659.20	1,889,853.80	2,799,754.73	36.19355449	-107.57351424	
6,000.00	90.14	312.552	5,287.76	-58.47	-732.87	1,889,921.43	2,799,681.06	36.19374080	-107.57376329	
6,100.00	90.14	312.552	5,287.51	9.16	-806.54	1,889,989.05	2,799,607.39	36.19392712	-107.57401234	
6,200.00	90.14	312.552	5,287.27	76.79	-880.20	1,890,056.68	2,799,533.73	36.19411343	-107.57426139	
6,300.00	90.14	312.552	5,287.02	144.41	-953.87	1,890,124.30	2,799,460.06	36.19429974	-107.57451044	
6,400.00	90.14	312.552	5,286.77	212.04	-1,027.53	1,890,191.93	2,799,386.40	36.19448606	-107.57475949	
6,500.00	90.14	312.552	5,286.52	279.66	-1,101.20	1,890,259.55	2,799,312.73	36.19467237	-107.57500854	
6,600.00	90.14	312.552	5,286.27	347.29	-1,174.87	1,890,327.18	2,799,239.06	36.19485868	-107.57525759	
6,700.00	90.14	312.552	5,286.02	414.91	-1,248.53	1,890,394.80	2,799,165.40	36.19504499	-107.57550665	
6,800.00	90.14	312.552	5,285.77	482.54	-1,322.20	1,890,462.43	2,799,091.73	36.19523130	-107.57575570	
6,900.00	90.14	312.552	5,285.52	550.17	-1,395.87	1,890,530.06	2,799,018.07	36.19541761	-107.57600476	
7,000.00	90.14	312.552	5,285.27	617.79	-1,469.53	1,890,597.68	2,798,944.40	36.19560392	-107.57625382	
7,100.00	90.14	312.552	5,285.02	685.42	-1,543.20	1,890,665.31	2,798,870.73	36.19579023	-107.57650288	
7,200.00	90.14	312.552	5,284.77	753.04	-1,616.86	1,890,732.93	2,798,797.07	36.19597654	-107.57675194	
7,300.00	90.14	312.552	5,284.52	820.67	-1,690.53	1,890,800.56	2,798,723.40	36.19616284	-107.57700100	
7,400.00	90.14	312.552	5,284.27	888.29	-1,764.20	1,890,868.18	2,798,649.74	36.19634915	-107.57725006	
7,500.00	90.14	312.552	5,284.02	955.92	-1,837.86	1,890,935.81	2,798,576.07	36.19653546	-107.57749913	
7,600.00	90.14	312.552	5,283.77	1,023.55	-1,911.53	1,891,003.43	2,798,502.40	36.19672176	-107.57774819	
7,700.00	90.14	312.552	5,283.52	1,091.17	-1,985.19	1,891,071.06	2,798,428.74	36.19690807	-107.57799726	
7,800.00	90.14	312.552	5,283.27	1,158.80	-2,058.86	1,891,138.69	2,798,355.07	36.19709437	-107.57824633	
7,900.00	90.14	312.552	5,283.02	1,226.42	-2,132.53	1,891,206.31	2,798,281.41	36.19728068	-107.57849539	
8,000.00	90.14	312.552	5,282.77	1,294.05	-2,206.19	1,891,273.94	2,798,207.74	36.19746698	-107.57874446	
8,100.00	90.14	312.552	5,282.52	1,361.67	-2,279.86	1,891,341.56	2,798,134.07	36.19765328	-107.57899354	
8,200.00	90.14	312.552	5,282.27	1,429.30	-2,353.53	1,891,409.19	2,798,060.41	36.19783959	-107.57924261	
8,300.00	90.14	312.552	5,282.02	1,496.93	-2,427.19	1,891,476.81	2,797,986.74	36.19802589	-107.57949168	
8,400.00	90.14	312.552	5,281.77	1,564.55	-2,500.86	1,891,544.44	2,797,913.08	36.19821219	-107.57974076	
8,500.00	90.14	312.552	5,281.52	1,632.18	-2,574.52	1,891,612.06	2,797,839.41	36.19839849	-107.57998983	
8,600.00	90.14	312.552	5,281.27	1,699.80	-2,648.19	1,891,679.69	2,797,765.74	36.19858479	-107.58023891	
8,700.00	90.14	312.552	5,281.02	1,767.43	-2,721.86	1,891,747.32	2,797,692.08	36.19877109	-107.58048799	
8,800.00	90.14	312.552	5,280.77	1,835.05	-2,795.52	1,891,814.94	2,797,618.41	36.19895739	-107.58073707	
8,900.00	90.14	312.552	5,280.52	1,902.68	-2,869.19	1,891,882.57	2,797,544.75	36.19914369	-107.58098615	
9,000.00	90.14	312.552	5,280.27	1,970.31	-2,942.86	1,891,950.19	2,797,471.08	36.19932999	-107.58123523	
9,100.00	90.14	312.552	5,280.02	2,037.93	-3,016.52	1,892,017.82	2,797,397.41	36.19951629	-107.58148431	
9,200.00	90.14	312.552	5,279.77	2,105.56	-3,090.19	1,892,085.44	2,797,323.75	36.19970259	-107.58173340	
9,300.00	90.14	312.552	5,279.52	2,173.18	-3,163.85	1,892,153.07	2,797,250.08	36.19988888	-107.58198248	
9,400.00	90.14	312.552	5,279.27	2,240.81	-3,237.52	1,892,220.69	2,797,176.42	36.20007518	-107.58223157	
9,500.00	90.14	312.552	5,279.02	2,308.43	-3,311.19	1,892,288.32	2,797,102.75	36.20026148	-107.58248066	
9,600.00	90.14	312.552	5,278.77	2,376.06	-3,384.85	1,892,355.95	2,797,029.08	36.20044777	-107.58272975	
9,700.00	90.14	312.552	5,278.52	2,443.69	-3,458.52	1,892,423.57	2,796,955.42	36.20063407	-107.58297884	



Planning Report - Geographic



Database:	DT_Jul1724_v17	Local Co-ordinate Reference:	Well North Alamito Unit 311H
Company:	Enduring Resources LLC	TVD Reference:	RKB=6946+23.5 @ 6969.50ft
Project:	Sandoval County, New Mexico NAD83 NmW	MD Reference:	RKB=6946+23.5 @ 6969.50ft
Site:	North Alamito Unit (4, 301,311 & 312)	North Reference:	Grid
Well:	North Alamito Unit 311H	Survey Calculation Method:	Minimum Curvature
Wellbore:	Original Hole		
Design:	rev0		

Planned Survey										
Measured Depth (ft)	Inclination (°)	Azimuth (°)	Vertical Depth (ft)	+N/-S (ft)	+E/-W (ft)	Map Northing (usft)	Map Easting (usft)	Latitude	Longitude	
9,800.00	90.14	312.552	5,278.27	2,511.31	-3,532.18	1,892,491.20	2,796,881.75	36.20082036	-107.58322793	
9,900.00	90.14	312.552	5,278.02	2,578.94	-3,605.85	1,892,558.82	2,796,808.09	36.20100666	-107.58347702	
10,000.00	90.14	312.552	5,277.77	2,646.56	-3,679.52	1,892,626.45	2,796,734.42	36.20119295	-107.58372611	
10,100.00	90.14	312.552	5,277.52	2,714.19	-3,753.18	1,892,694.07	2,796,660.75	36.20137924	-107.58397521	
10,200.00	90.14	312.552	5,277.27	2,781.81	-3,826.85	1,892,761.70	2,796,587.09	36.20156554	-107.58422430	
10,300.00	90.14	312.552	5,277.02	2,849.44	-3,900.52	1,892,829.32	2,796,513.42	36.20175183	-107.58447340	
10,400.00	90.14	312.552	5,276.77	2,917.07	-3,974.18	1,892,896.95	2,796,439.76	36.20193812	-107.58472250	
10,500.00	90.14	312.552	5,276.52	2,984.69	-4,047.85	1,892,964.58	2,796,366.09	36.20212441	-107.58497160	
10,600.00	90.14	312.552	5,276.27	3,052.32	-4,121.51	1,893,032.20	2,796,292.42	36.20231070	-107.58522070	
10,700.00	90.14	312.552	5,276.02	3,119.94	-4,195.18	1,893,099.83	2,796,218.76	36.20249699	-107.58546980	
10,800.00	90.14	312.552	5,275.77	3,187.57	-4,268.85	1,893,167.45	2,796,145.09	36.20268328	-107.58571890	
10,900.00	90.14	312.552	5,275.52	3,255.19	-4,342.51	1,893,235.08	2,796,071.42	36.20286957	-107.58596801	
11,000.00	90.14	312.552	5,275.27	3,322.82	-4,416.18	1,893,302.70	2,795,997.76	36.20305586	-107.58621711	
11,100.00	90.14	312.552	5,275.02	3,390.45	-4,489.84	1,893,370.33	2,795,924.09	36.20324214	-107.58646622	
11,200.00	90.14	312.552	5,274.77	3,458.07	-4,563.51	1,893,437.95	2,795,850.43	36.20342843	-107.58671533	
11,300.00	90.14	312.552	5,274.52	3,525.70	-4,637.18	1,893,505.58	2,795,776.76	36.20361472	-107.58696444	
11,400.00	90.14	312.552	5,274.27	3,593.32	-4,710.84	1,893,573.21	2,795,703.09	36.20380100	-107.58721355	
11,508.97	90.14	312.552	5,274.00	3,667.01	-4,791.12	1,893,646.90	2,795,622.82	36.20400400	-107.58748500	
PBHL/TD @ 11508.97 MD 5274.00 TVD										

Design Targets										
Target Name	Dip Angle (°)	Dip Dir. (°)	TVD (ft)	+N/-S (ft)	+E/-W (ft)	Northing (usft)	Easting (usft)	Latitude	Longitude	
North Alamito 311H vert - hit/miss target - Shape - Point	0.00	0.000	4,715.60	-661.06	-76.45	1,889,318.83	2,800,337.48	36.19208059	-107.57154414	
North Alamito 311H LTP - plan hits target center - Point	0.00	0.000	5,274.00	3,667.01	-4,791.12	1,893,646.90	2,795,622.82	36.20400400	-107.58748500	
North Alamito 311H vs=(- plan misses target center by 28.71ft at 5504.98ft MD (5261.46 TVD, -391.33 N, -370.27 E) - Point	0.00	0.000	5,289.00	-396.82	-364.29	1,889,583.07	2,800,049.64	36.19280860	-107.57251723	
North Alamito 311H FTP - plan misses target center by 33.00ft at 5493.33ft MD (5257.81 TVD, -398.81 N, -362.12 E) - Point	0.00	0.000	5,289.00	-406.11	-354.17	1,889,573.78	2,800,059.76	36.19278300	-107.57248300	



Planning Report - Geographic



Database:	DT_Jul1724_v17	Local Co-ordinate Reference:	Well North Alamito Unit 311H
Company:	Enduring Resources LLC	TVD Reference:	RKB=6946+23.5 @ 6969.50ft
Project:	Sandoval County, New Mexico NAD83 NmW	MD Reference:	RKB=6946+23.5 @ 6969.50ft
Site:	North Alamito Unit (4, 301,311 & 312)	North Reference:	Grid
Well:	North Alamito Unit 311H	Survey Calculation Method:	Minimum Curvature
Wellbore:	Original Hole		
Design:	rev0		

Formations					
Measured Depth (ft)	Vertical Depth (ft)	Name	Lithology	Dip (°)	Dip Direction (°)
1,090.04	1,090.00	Ojo Alamo		-0.140	312.552
1,190.33	1,190.01	Kirtland		-0.140	312.552
1,352.04	1,350.05	Fruitland		-0.140	312.552
1,648.35	1,640.13	Pictured Cliffs		-0.140	312.552
1,811.89	1,800.18	Lewis		-0.140	312.552
2,067.42	2,050.26	Chacra_A		-0.140	312.552
3,181.53	3,140.59	Cliff House_Basal		-0.140	312.552
3,222.42	3,180.60	Menefee		-0.140	312.552
4,070.78	4,010.85	Point Lookout		-0.140	312.552
4,290.38	4,225.91	Mancos		-0.140	312.552
4,607.24	4,540.95	MNCS_A		-0.140	312.552
4,702.24	4,635.95	MNCS_B		-0.140	312.552
4,797.24	4,730.95	MNCS_C		-0.140	312.552
4,837.32	4,770.95	MNCS_Cms		-0.140	312.552
4,970.56	4,900.88	MNCS_D		-0.140	312.552
5,103.68	5,020.74	MNCS_E		-0.140	312.552
5,164.82	5,070.65	MNCS_F		-0.140	312.552
5,275.63	5,150.47	MNCS_G		-0.140	312.552
5,378.83	5,210.26	MNCS_H		-0.140	312.552
5,535.30	5,269.91	MNCS_I		-0.140	312.552

Plan Annotations					
Measured Depth (ft)	Vertical Depth (ft)	Local Coordinates		Comment	
		+N/-S (ft)	+E/-W (ft)		
1,000.00	1,000.00	0.00	0.00	KOP Begin 3°/100' build	
1,395.33	1,392.51	-40.50	-4.68	Begin 11.86° tangent	
4,236.56	4,173.09	-620.56	-71.77	Begin 3°/100' drop	
4,631.89	4,565.60	-661.06	-76.45	Begin vertical hold	
4,781.89	4,715.60	-661.06	-76.45	Begin 10°/100' build	
5,481.89	5,254.00	-406.11	-354.17		
5,683.32	5,288.56	-272.62	-499.58	Begin 90.14° lateral	
11,508.97	5,274.00	3,667.01	-4,791.12	PBHL/TD @ 11508.97 MD 5274.00 TVD	



United States Department of the Interior

BUREAU OF LAND MANAGEMENT
Farmington District Office
6251 College Blvd, Suite A
Farmington, New Mexico 87402



In Reply Refer To:
3162.3-1(NMF0110)

DJR OPERATING LLC
#311H N ALAMITO UNIT
APD ID: 10400106357

GENERAL REQUIREMENTS FOR OIL AND GAS OPERATIONS ON FEDERAL AND INDIAN LEASES

The following special requirements apply and are effective when **checked**:

- A. Note all surface/drilling conditions of approval attached.
- B. The required wait on cement (WOC) time will be a minimum of 500 psi compressive strength at 60 degrees. Blowout preventor (BOP) nipple-up operations may then be initiated
- C. Test all casing strings below the conductor casing to .22 psi/ft. of casing string length or 1500 psi, whichever is greater, but not to exceed 70% of the minimum internal yield (burst) for a minimum of 30 minutes. If pressure declines more than 10 percent in 30 minutes, corrective action shall be taken.
- D. Communitization Agreement covering the acreage dedicated to this well must be filed for approval with the Bureau of Land Management, New Mexico State Office, Reservoir Management Group, 301 Dinosaur Trail, Santa Fe, New Mexico 87508.
The effective date of the agreement must be **prior** to any sales.
- E. The use of co-flex hose is authorized contingent upon the following:
 1. From the BOP to the choke manifold: the co-flex hose must be hobbled on both ends and saddle to prevent whip.
 2. From the choke manifold to the discharge tank: the co-flex hoses must be as straight as practical, hobbled on both ends and anchored to prevent whip.
 3. The co-flex hose pressure rating must be at least commensurate with approved BOPE.

INTERIOR REGION 7 • UPPER COLORADO BASIN

COLORADO, NEW MEXICO, UTAH, WYOMING

I. GENERAL

- A. Full compliance with all applicable laws and regulations, with the approved Permit to drill, and with the approved Surface Use and Operations Plan is required. Lessees and/or operators are fully accountable for the actions of their contractors and subcontractors. Failure to comply with these requirements and the filing of required reports will result in strict enforcement pursuant to 43 CFR 3163.1 or 3163.2.
- B. Each well shall have a well sign in legible condition from spud date to final abandonment. The sign should show the operator's name, lease serial number, or unit name, well number, location of the well, and whether lease is Tribal or Allotted, (See 43 CFR 3162.6(b)).
- C. A complete copy of the approved Application for Permit to Drill, along with any conditions of approval, shall be available to authorized personnel at the drill site whenever active drilling operations are under way.
- D. For Wildcat wells only, a drilling operations progress report is to be submitted, to the BLM-Field Office, weekly from the spud date until the well is completed and the Well Completion Report is filed. The report should be on 8-1/2 x 11 inch paper, and each page should identify the well by; operator's name, well number, location and lease number.
- E. As soon as practical, notice is required of all blowouts, fires and accidents involving life-threatening injuries or loss of life. (See NTL-3A).
- F. BOP equipment (except the annular preventer) shall be tested utilizing a test plug to full working pressure for 10 minutes. No bleed-off of pressure is acceptable. (See 43 CFR 3172.6(b)(9)(ii)).
- G. The operator shall have sufficient weighting materials and lost circulation materials on location in the event of a pressure kick or in the event of lost circulation. (See 43 CFR 3172.8(a)).
- H. The flare line(s) discharge shall be located not less than 100 feet from the well head, having straight lines unless turns are targeted with running tees, and shall be positioned downwind of the prevailing wind direction and shall be anchored. The flare system shall have an effective method for ignition. Where noncombustible gas is likely or expected to be vented, the system shall be provided supplemental fuel for ignition and to maintain a continuous flare. (See 43 CFR 3172.8(b)(7)).
- I. Prior approval by the BLM-Authorized Office (Drilling and Production Section) is required for variance from the approved drilling program and before commencing plugging operations, plug back work, casing repair work, corrective cementing operations, or suspending drilling operations indefinitely. Emergency approval may be obtained orally, but such approval is contingent upon filing of a Notice of Intent sundry within three business days. **Any changes to the approved plan or any questions regarding drilling operations should be directed to BLM during regular business hours at 505-564-7600. Emergency program changes after hours should be directed to Virgil Lucero at 505-793-1836.**
- J. **The Inspection and Enforcement Section (I&E), phone number (505-564-7750) is to be notified at least 24 hours in advance of BOP test, spudding, cementing, or plugging operations so that a BLM representative may witness the operations.**

- K. From the time drilling operations are initiated and until drilling operations are completed, a member of the drilling crew or the tool pusher shall maintain rig surveillance at all times, unless the well is secured with blowout preventers or cement plugs.
- L. If for any reason, drilling operations are suspended for more than 90 days, a written notice must be provided to this office outlining your plans for this well.
- M. **Commingling:** No production (oil, gas, and water) from the subject well should start until Sundry Notices (if necessary) granting variances from applicable regulations as related to commingling and off-lease measurement are approved by this office. (See 43 CFR 3173.14)

II. REPORTING REQUIREMENTS

- A. For reporting purposes, all well Sundry notices, well completion and other well actions shall be referenced by the appropriate lease, communitization agreement and/or unit agreement numbers.
- B. The following reports shall be filed with the BLM-Authorized Officer online through AFMSS 2 within 30 days after the work is completed.
 - 1. Provide complete information concerning.
 - a. Setting of each string of casing. Show size and depth of hole, grade and weight of casing, depth set, depth of all cementing tools that are used, amount (in cubic feet) and types of cement used, whether cement circulated to surface and all cement tops in the casing annulus, casing test method and results, and the date work was done. Show spud date on first report submitted.
 - b. Intervals tested, perforated (include size, number and location of perforations), acidized, or fractured; and results obtained. Provide date work was done on well completion report and completion sundry notice.
 - c. Subsequent Report of Abandonment, show the way the well was plugged, including depths where casing was cut and pulled, intervals (by depths) where cement plugs were replaced, and dates of the operations.
 - 2. Well Completion Report will be submitted with 30 days after well has been completed.
 - a. Initial Bottom Hole Pressure (BHP) for the producing formations. Show the BHP on the completion report. The pressure may be: 1) measured with a bottom hole bomb, or; 2) calculated based on shut in surface pressures (minimum seven day buildup) and fluid level shot.
 - 3. Submit a cement evaluation log if cement is not circulated to surface.
- C. Production Startup Notification is required no later than the 5th business day after any well begins production on which royalty is due anywhere on a lease site or allocated to a lease site or resumes production in the case of a well which has been off production for more than 90 days. The operator shall notify the Authorized Officer by letter or Sundry Notice, Form 3160-5, or orally to be followed by a letter or Sundry Notice, of the date on which such production has begun or resumed. CFR 43 3162.4-1(c).

III. DRILLER'S LOG

The following shall be entered in the daily driller's log: 1) Blowout preventer pressures tests, including test pressures and results, 2) Blowout preventer tests for proper functioning, 3) Blowout prevention drills conducted, 4) Casing run, including size, grade, weight, and depth set, 5) How pipe was cemented, including amount of cement, type, whether cement circulated to surface, location of cementing tools, etc., 6) Waiting on cement time for each casing string, 7) Casing pressure tests after cementing, including test pressure and results, and 8) Estimated amounts of oil and gas recovered and/or produced during drill stem test.

IV. GAS FLARING

Gas produced from this well may not be vented or flared beyond an initial, authorized test period of *** Days**, 20 MMCF following its (completion)(recompletion), or flowback has been routed to the production separator, whichever first occurs, without the prior, written approval of the authorized officer in accordance with 43 CFR 3179.81. Should gas be vented or flared without approval beyond the test period authorized above, you may be directed to shut-in the well until the gas can be captured or approval to continue venting or flaring as uneconomic is granted. You shall be required to compensate the lessor for the portion of the gas vented or flared without approval which is determined to have been avoidably lost.

***30 days**, unless a longer test period is specifically approved by the authorized officer. The 30-day period will commence upon the beginning of flowback following completion or recompletion.

V. SAFETY

- A. All rig heating stoves are to be of the explosion-proof type.
- B. Rig safety lines are to be installed.
- C. Hard hats and other Personal Protective Equipment (PPE) must be utilized.

VI. CHANGE OF PLANS OR ABANDONMENT

- A. Any changes of plans required to mitigate unanticipated conditions encountered during drilling operations, will require approval as set forth in Section 1.I.
- B. If the well is dry, it is to be plugged in accordance with 43 CFR 3162.3-4, approval of the proposed plugging program is required as set forth in Section 1.I. The report should show the total depth reached, the reason for plugging, and the proposed intervals, by depths, where cement plugs are to be placed, type of plugging mud, etc. A Subsequent Report of Abandonment is required as set forth in Section II.B.1c.
- C. Unless a well has been properly cased and cemented, or properly plugged, the drilling rig must not be moved from the drill site without prior approval from the BLM-Authorized Officer.

VII. PHONE NUMBERS

- A. **For BOPE tests, cementing, and plugging operations the phone number is 505-564-7750 and must be called 24 hours in advance in order that a BLM representative may witness the operations.**

Sante Fe Main Office
Phone: (505) 476-3441

General Information
Phone: (505) 629-6116

Online Phone Directory
<https://www.emnrd.nm.gov/ocd/contact-us>

State of New Mexico
Energy, Minerals and Natural Resources
Oil Conservation Division
1220 S. St Francis Dr.
Santa Fe, NM 87505

ACKNOWLEDGMENTS

Action 545081

ACKNOWLEDGMENTS

Operator: DJR OPERATING, LLC 200 Energy Court Farmington, NM 87401	OGRID: 371838
	Action Number: 545081
	Action Type: [C-101] BLM - Federal/Indian Land Lease (Form 3160-3)

ACKNOWLEDGMENTS

<input checked="" type="checkbox"/>	I hereby certify that no additives containing PFAS chemicals will be added to the completion or recompletion of this well.
-------------------------------------	--

Sante Fe Main Office
Phone: (505) 476-3441

General Information
Phone: (505) 629-6116

Online Phone Directory
<https://www.emnrd.nm.gov/oecd/contact-us>

**State of New Mexico
Energy, Minerals and Natural Resources
Oil Conservation Division
1220 S. St Francis Dr.
Santa Fe, NM 87505**

CONDITIONS

Action 545081

CONDITIONS

Operator: DJR OPERATING, LLC 200 Energy Court Farmington, NM 87401	OGRID: 371838
	Action Number: 545081
	Action Type: [C-101] BLM - Federal/Indian Land Lease (Form 3160-3)

CONDITIONS

Created By	Condition	Condition Date
scrues76	Cement is required to circulate on both surface and intermediate1 strings of casing.	1/21/2026
scrues76	If cement does not circulate on any string, a Cement Bond Log (CBL) is required for that string of casing.	1/21/2026
ward.rikala	Notify the OCD 24 hours prior to casing & cement.	3/27/2026
ward.rikala	File As Drilled C-102 and a directional Survey with C-104 completion packet.	3/27/2026
ward.rikala	Once the well is spud, to prevent ground water contamination through whole or partial conduits from the surface, the operator shall drill without interruption through the fresh water zone or zones and shall immediately set in cement the water protection string.	3/27/2026
ward.rikala	Oil base muds are not to be used until fresh water zones are cased and cemented providing isolation from the oil or diesel. This includes synthetic oils. Oil based mud, drilling fluids and solids must be contained in a steel closed loop system.	3/30/2026
ward.rikala	If the method of isolation was not by circulation, a CBL must be performed; if strata isolation is not achieved, then remediation will be required before further operations.	3/30/2026