

U.S. Department of the Interior  
BUREAU OF LAND MANAGEMENT

<b>Well Name:</b> EVIL OLIVE 26-35 FEDERAL COM	<b>Well Location:</b> T22S / R31E / SEC 26 / NESW / 32.3624233 / -103.7514483	<b>County or Parish/State:</b> EDDY / NM
<b>Well Number:</b> 2H	<b>Type of Well:</b> OIL WELL	<b>Allottee or Tribe Name:</b>
<b>Lease Number:</b> NMNM62590	<b>Unit or CA Name:</b>	<b>Unit or CA Number:</b>
<b>US Well Number:</b> 3001555176	<b>Operator:</b> OXY USA INCORPORATED	

**Notice of Intent**

**Sundry ID:** 2896602

**Type of Submission:** Notice of Intent

**Type of Action:** APD Change

**Date Sundry Submitted:** 02/18/2026

**Time Sundry Submitted:** 01:49

**Date proposed operation will begin:** 07/01/2026

**Procedure Description:** OXY USA Inc., respectfully requests to amend the subject AAPD to revise the Well Name, SHL, Well Pad, HSU, TVD and Drill Plan. Old Well Name: EVIL OLIVE 26\_35 FEDERAL COM 2H New Well Name: OLIVE WON UNIT 2H Old SHL: 2614' FSL 1763' FWL New SHL: 2449' FSL 2261' FEL Old Well Pad: LSTTNK\_22S31E\_26\_1 New Well Pad: LSTTNK\_22S31E\_26\_2 Old HSU: 240 acres New HSU: 960 acres Old TVD: 9851' New TVD: 9770' \*THERE IS NO ADDITIONAL SURFACE DISTURBANCE RELATED TO THIS SUNDRY" Attached is the updated C102, drill plan, directional, Blanket Design, Updated Variances and APD Change Worksheet.

**NOI Attachments**

**Procedure Description**

- OLIVEWONUNIT2H\_API\_BTC\_SC\_10.750\_40.5ppf\_J55\_20260218134813.pdf
- OLIVEWONUNIT2H\_13inADAPT\_4S\_10x15\_20260218134808.pdf
- Blanket\_Design\_B\_Pad\_Review\_Document\_LSTTNK\_22S31E\_26\_2\_20260218134803.pdf
- OLIVEWONUNIT2H\_DrillPlan\_4S\_20260218134757.pdf
- OLIVEWONUNIT2H\_VAM\_DWC\_C\_HT\_IS\_5.500in\_20ppf\_P110RY\_20260218134741.pdf
- OLIVEWONUNIT2H\_13inADAPT\_13.375in\_7.625in\_10x15\_20260218134735.pdf
- OLIVEWONUNIT2H\_CombinedVariances\_2026\_20260218134728.pdf
- Combined\_Blanket\_Design\_\_\_A1\_\_\_A2\_\_\_B\_\_\_OXY\_\_\_3S\_Slim\_v8.0\_and\_4S\_Slim\_Contingency\_v4.0\_20260218134721.pdf

Well Name: EVIL OLIVE 26-35  
FEDERAL COM

Well Location: T22S / R31E / SEC 26 /  
NESW / 32.3624233 / -103.7514483

County or Parish/State: EDDY /  
NM

Well Number: 2H

Type of Well: OIL WELL

Allottee or Tribe Name:

Lease Number: NMNM62590

Unit or CA Name:

Unit or CA Number:

US Well Number: 3001555176

Operator: OXY USA INCORPORATED

Blanket\_Design\_A\_Pad\_Review\_Document\_LSTTNK\_22S31E\_26\_2\_20260218134715.pdf

OLIVEWONUNIT2H\_DirectPlan\_20260218134710.pdf

OLIVEWONUNIT2H\_DrillPlan\_3S\_20260218134704.pdf

OLIVEWONUNIT2H\_C102\_20260218134658.pdf

OLIVEWONUNIT2H\_APDCHGSUNDRYWORKSHEET\_20260218134652.pdf

**Conditions of Approval**

**Additional**

OLIVE\_WON\_UNIT\_\_04092026\_\_SUNDRY\_COA\_20260409154438.pdf

**Operator**

*I certify that the foregoing is true and correct. Title 18 U.S.C. Section 1001 and Title 43 U.S.C. Section 1212, make it a crime for any person knowingly and willfully to make to any department or agency of the United States any false, fictitious or fraudulent statements or representations as to any matter within its jurisdiction. Electronic submission of Sundry Notices through this system satisfies regulations requiring a*

**Operator Electronic Signature:** MELISSA GUIDRY

**Signed on:** FEB 18, 2026 01:48 PM

**Name:** OXY USA INCORPORATED

**Title:** Advisor Regulatory Sr.

**Street Address:** 5 GREENWAY PLAZA SUITE 110

**City:** HOUSTON **State:** TX

**Phone:** (713) 497-2481

**Email address:** MELISSA\_GUIDRY@OXY.COM

**Field**

**Representative Name:**

**Street Address:**

**City:** **State:** **Zip:**

**Phone:**

**Email address:**

**BLM Point of Contact**

**BLM POC Name:** CHRISTOPHER WALLS

**BLM POC Title:** Petroleum Engineer

**BLM POC Phone:** 5752342234

**BLM POC Email Address:** CWALLS@BLM.GOV

**Disposition:** Approved

**Disposition Date:** 04/09/2026

**Signature:** Chris Walls

Form 3160-5  
(October 2024)

UNITED STATES  
DEPARTMENT OF THE INTERIOR  
BUREAU OF LAND MANAGEMENT

FORM APPROVED  
OMB No. 1004-0220  
Expires: October 31, 2027

**SUNDRY NOTICES AND REPORTS ON WELLS**  
**Do not use this form for proposals to drill or to re-enter an abandoned well. Use Form 3160-3 (APD) for such proposals.**

<b>SUBMIT IN TRIPLICATE - Other instructions on page 2</b>		5. Lease Serial No.
1. Type of Well <input type="checkbox"/> Oil Well <input type="checkbox"/> Gas Well <input type="checkbox"/> Other		6. If Indian, Allottee or Tribe Name
2. Name of Operator		7. If Unit of CA/Agreement, Name and/or No.
3a. Address	3b. Phone No. (include area code)	8. Well Name and No.
4. Location of Well (Footage, Sec., T.,R.,M., or Survey Description)		9. API Well No.
		10. Field and Pool or Exploratory Area
		11. Country or Parish, State

12. CHECK THE APPROPRIATE BOX(ES) TO INDICATE NATURE OF NOTICE, REPORT OR OTHER DATA

TYPE OF SUBMISSION	TYPE OF ACTION			
<input type="checkbox"/> Notice of Intent	<input type="checkbox"/> Acidize	<input type="checkbox"/> Deepen	<input type="checkbox"/> Production (Start/Resume)	<input type="checkbox"/> Water Shut-Off
<input type="checkbox"/> Subsequent Report	<input type="checkbox"/> Alter Casing	<input type="checkbox"/> Hydraulic Fracturing	<input type="checkbox"/> Reclamation	<input type="checkbox"/> Well Integrity
<input type="checkbox"/> Final Abandonment Notice	<input type="checkbox"/> Casing Repair	<input type="checkbox"/> New Construction	<input type="checkbox"/> Recomplete	<input type="checkbox"/> Other
	<input type="checkbox"/> Change Plans	<input type="checkbox"/> Plug and Abandon	<input type="checkbox"/> Temporarily Abandon	
	<input type="checkbox"/> Convert to Injection	<input type="checkbox"/> Plug Back	<input type="checkbox"/> Water Disposal	

13. Describe Proposed or Completed Operation: Clearly state all pertinent details, including estimated starting date of any proposed work and approximate duration thereof. If the proposal is to deepen directionally or recomplete horizontally, give subsurface locations and measured and true vertical depths of all pertinent markers and zones. Attach the Bond under which the work will be performed or provide the Bond No. on file with BLM/BIA. Required subsequent reports must be filed within 30 days following completion of the involved operations. If the operation results in a multiple completion or recompletion in a new interval, a Form 3160-4 must be filed once testing has been completed. Final Abandonment Notices must be filed only after all requirements, including reclamation, have been completed and the operator has determined that the site is ready for final inspection.)

14. I hereby certify that the foregoing is true and correct. Name (Printed/Typed)	
Signature	Title
	Date

**THE SPACE FOR FEDERAL OR STATE OFFICE USE**

Approved by		
Conditions of approval, if any, are attached. Approval of this notice does not warrant or certify that the applicant holds legal or equitable title to those rights in the subject lease which would entitle the applicant to conduct operations thereon.	Title	Date
	Office	

Title 18 U.S.C Section 1001 and Title 43 U.S.C Section 1212, make it a crime for any person knowingly and willfully to make to any department or agency of the United States any false, fictitious or fraudulent statements or representations as to any matter within its jurisdiction.

(Instructions on page 2)

## GENERAL INSTRUCTIONS

This form is designed for submitting proposals to perform certain well operations and reports of such operations when completed as indicated on Federal and Indian lands pursuant to applicable Federal law and regulations. Any necessary special instructions concerning the use of this form and the number of copies to be submitted, particularly with regard to local area or regional procedures and practices, are either shown below, will be issued by or may be obtained from the local Federal office.

## SPECIFIC INSTRUCTIONS

*Item 4* - Locations on Federal or Indian land should be described in accordance with Federal requirements. Consult the local Federal office for specific instructions.

*Item 13*: Proposals to abandon a well and subsequent reports of abandonment should include such special information as is required by the local Federal office. In addition, such proposals and reports should include reasons for the abandonment; data on any former or present productive zones or other zones with present significant fluid contents not sealed off by cement or otherwise; depths (top and bottom) and method of placement of cement plugs; mud or other material placed below, between and above plugs; amount, size, method of parting of any casing, liner or tubing pulled and the depth to the top of any tubing left in the hole; method of closing top of well and date well site conditioned for final inspection looking for approval of the abandonment. If the proposal will involve **hydraulic fracturing operations**, you must comply with 43 CFR 3162.3-3, including providing information about the protection of usable water. Operators should provide the best available information about all formations containing water and their depths. This information could include data and interpretation of resistivity logs run on nearby wells. Information may also be obtained from state or tribal regulatory agencies and from local BLM offices.

## NOTICES

The privacy Act of 1974 and the regulation in 43 CFR 2.48(d) provide that you be furnished the following information in connection with information required by this application.

AUTHORITY: 30 U.S.C. 181 et seq., 351 et seq., 25 U.S.C. 396; 43 CFR 3160.

PRINCIPAL PURPOSE: The information is used to: (1) Evaluate, when appropriate, approve applications, and report completion of subsequent well operations, on a Federal or Indian lease; and (2) document for administrative use, information for the management, disposal and use of National Resource lands and resources, such as: (a) evaluating the equipment and procedures to be used during a proposed subsequent well operation and reviewing the completed well operations for compliance with the approved plan; (b) requesting and granting approval to perform those actions covered by 43 CFR 3162.3-2, 3162.3-3, and 3162.3-4; (c) reporting the beginning or resumption of production, as required by 43 CFR 3162.4-1(c) and (d) analyzing future applications to drill or modify operations in light of data obtained and methods used.

ROUTINE USES: Information from the record and/or the record will be transferred to appropriate Federal, State, local or foreign agencies, when relevant to civil, criminal or regulatory investigations or prosecutions in connection with congressional inquiries or to consumer reporting agencies to facilitate collection of debts owed the Government.

EFFECT OF NOT PROVIDING THE INFORMATION: Filing of this notice and report and disclosure of the information is mandatory for those subsequent well operations specified in 43 CFR 3162.3-2, 3162.3-3, 3162.3-4.

The Paperwork Reduction Act of 1995 requires us to inform you that:

The BLM collects this information to evaluate proposed and/or completed subsequent well operations on Federal or Indian oil and gas leases.

Response to this request is mandatory.

The BLM would like you to know that you do not have to respond to this or any other Federal agency-sponsored information collection unless it displays a currently valid OMB control number.

**BURDEN HOURS STATEMENT:** Public reporting burden for this form is estimated to average 8 hours per response, including the time for reviewing instructions, gathering and maintaining data, and completing and reviewing the form. Direct comments regarding the burden estimate or any other aspect of this form to U.S. Department of the Interior, Bureau of Land Management (1004-0137), Bureau Information Collection Clearance Officer (WO-630), 1849 C St., N.W., Mail Stop 401 LS, Washington, D.C. 20240

## Additional Information

### Additional Remarks

New HSU: 960 acres

Old TVD: 9851'

New TVD: 9770'

\*THERE IS NO ADDITIONAL SURFACE DISTURBANCE RELATED TO THIS SUNDRY"

Attached is the updated C102, drill plan, directional, Blanket Design, Updated Variances and APD Change Worksheet.

### Location of Well

0. SHL: NESW / 2614 FSL / 1763 FWL / TWSP: 22S / RANGE: 31E / SECTION: 26 / LAT: 32.3624233 / LONG: -103.7514483 ( TVD: 0 feet, MD: 0 feet )

PPP: NENW / 1 FNL / 1740 FWL / TWSP: 22S / RANGE: 31E / SECTION: 35 / LAT: 32.3552383 / LONG: -103.7515239 ( TVD: 9851 feet, MD: 12758 feet )

PPP: NESW / 2538 FSL / 1740 FWL / TWSP: 22S / RANGE: 31E / SECTION: 26 / LAT: 32.3622146 / LONG: -103.7515229 ( TVD: 9851 feet, MD: 10220 feet )

BHL: SESW / 20 FSL / 1740 FWL / TWSP: 22S / RANGE: 31E / SECTION: 35 / LAT: 32.3407874 / LONG: -103.7515262 ( TVD: 9851 feet, MD: 18016 feet )

## PECOS DISTRICT DRILLING CONDITIONS OF APPROVAL

<b>OPERATOR'S NAME:</b>	OXY USA INC.
<b>WELL NAME:</b>	OLIVE WON UNIT
<b>WELL NUMBERS SUNDRIED:</b>	1H, 2H, 3H, 11H, 12H and 13H
<b>LOCATION:</b>	SEC26 T22S R31E -NMP
<b>COUNTY:</b>	Eddy County, New Mexico

**Create COAs**

<b>H<sub>2</sub>S</b>	<b>Cave / Karst</b>	<b>Waste Prevention Rule</b>
Present	Low	Waste Minimization Plan
<b>Potash</b>	<b>R-111-Q Design</b>	
Secretary & WIPP		
<b>Wellhead</b>	<b>Casing</b>	
Multibowl	3-String Well	
<input checked="" type="checkbox"/> Flex Hose <input checked="" type="checkbox"/> Break Testing	<input type="checkbox"/> Liner <input checked="" type="checkbox"/> Fluid <input type="checkbox"/> Casing Clearance	
	<b>Cementing</b>	
	<input type="checkbox"/> DV Tool <input checked="" type="checkbox"/> Bradenhead <input type="checkbox"/> Echometer <input checked="" type="checkbox"/> Offline Cement <input type="checkbox"/> Open Annulus <input type="checkbox"/> Pilot Hole	
<b>Special Requirements</b>		
<input type="checkbox"/> Capitan Reef	<input type="checkbox"/> Water Disposal	<input type="checkbox"/> COM <input checked="" type="checkbox"/> Unit

**A. HYDROGEN SULFIDE**

A Hydrogen Sulfide (H<sub>2</sub>S) Drilling Plan shall be activated AT SPUD. As a result, the Hydrogen Sulfide area must meet all requirements from 43 CFR 3176, which includes equipment and personnel/public protection items. If Hydrogen Sulfide is encountered, please provide measured values and formations to the BLM.

**B. CASING**

**NOTE: WELL APPROVED FOR DESIGNS A1, A2 AND B. WELL PARAMETERS WITHIN BOUNDARY CONDITIONS. REVIEW CEMENT VOLUMES TO ACHIEVE TIE BACKS LISTED BELOW.**

**A1**

1. The **10-3/4** inch surface casing shall be set at approximately **913** feet (a minimum of **70'** into the Rustler Anhydrite, above the salt, and below usable fresh water) and cemented to the surface.
  - a. If cement does not circulate to the surface, the appropriate BLM office shall be notified and a temperature survey utilizing an electronic-type temperature survey with surface log readout will be used or a cement bond log shall be run to verify the top of the cement. Temperature survey will be run a minimum of six hours after pumping cement and ideally between 8-10 hours after completing the cement job.
  - b. Wait on cement (WOC) time for a primary cement job will be a minimum of **8 hours** or **500 pounds compressive strength**, whichever is greater (including lead cement.)
  - c. Wait on cement (WOC) time for a remedial job will be a minimum of 4 hours after bringing cement to surface or 500 pounds compressive strength, whichever is greater.
  - d. If cement falls back, remedial cementing will be done prior to drilling out that string.

***Intermediate casing must be kept fluid filled to meet BLM minimum collapse requirement.***

2. The minimum required fill of cement behind the **7-5/8** inch intermediate casing is **cement to surface**. If cement does not circulate, see B.1.a, c-d above.
  - **Wait on cement (WOC) time for a primary cement job is to include the lead cement slurry** due to the presence of cave/karst, Capitan Reef, or potash features.

**Bradenhead Squeeze:** Operator has proposed to cement in two stages by conventionally cementing the first stage and performing a bradenhead squeeze on the second stage, contingent upon no returns to surface.

- a. **First stage:** Operator will cement with intent to reach the top of the **Brushy Canyon**.
  - b. **Second stage:** Operator to squeeze and top-out. Cement to meet requirements listed for this casing string. If cement does not circulate see B.1.a, c-d above.
3. The minimum required fill of cement behind the **5-1/2** inch production casing is **500 feet** into the previous casing.
    - **Wait on cement (WOC) time for a primary cement job is to include the lead cement slurry** due to the presence of cave/karst, Capitan Reef, or potash features.

**A2**

1. The **13-3/8** inch surface casing shall be set at approximately **913** feet (a minimum of **70'** into the Rustler Anhydrite, above the salt, and below usable fresh water) and cemented to the surface.
  - a. If cement does not circulate to the surface, the appropriate BLM office shall be notified and a temperature survey utilizing an electronic-type temperature survey with surface log readout will be used or a cement bond log shall be run to verify the top of the cement.

Temperature survey will be run a minimum of six hours after pumping cement and ideally between 8-10 hours after completing the cement job.

- b. Wait on cement (WOC) time for a primary cement job will be a minimum of **8 hours** or **500 pounds compressive strength**, whichever is greater (including lead cement.)
- c. Wait on cement (WOC) time for a remedial job will be a minimum of 4 hours after bringing cement to surface or 500 pounds compressive strength, whichever is greater.
- d. If cement falls back, remedial cementing will be done prior to drilling out that string.

***Intermediate casing must be kept fluid filled to meet BLM minimum collapse requirement.***

2. The minimum required fill of cement behind the **7-5/8** inch intermediate casing is **cement to surface**. If cement does not circulate, see B.1.a, c-d above.
  - **Wait on cement (WOC) time for a primary cement job is to include the lead cement slurry** due to the presence of cave/karst, Capitan Reef, or potash features.

**Bradenhead Squeeze:** Operator has proposed to cement in two stages by conventionally cementing the first stage and performing a bradenhead squeeze on the second stage, contingent upon no returns to surface.

- a. **First stage:** Operator will cement with intent to reach the top of the **Brushy Canyon**.
  - b. **Second stage:** Operator to squeeze and top-out. Cement to meet requirements listed for this casing string. If cement does not circulate see B.1.a, c-d above.
3. The minimum required fill of cement behind the **5-1/2** inch production casing is **500 feet** into the previous casing.
    - **Wait on cement (WOC) time for a primary cement job is to include the lead cement slurry** due to the presence of cave/karst, Capitan Reef, or potash features.

## **B**

1. The **13-3/8** inch surface casing shall be set at approximately **913** feet (a minimum of **70'** into the Rustler Anhydrite, above the salt, and below usable fresh water) and cemented to the surface.
  - a. If cement does not circulate to the surface, the appropriate BLM office shall be notified and a temperature survey utilizing an electronic-type temperature survey with surface log readout will be used or a cement bond log shall be run to verify the top of the cement. Temperature survey will be run a minimum of six hours after pumping cement and ideally between 8-10 hours after completing the cement job.
  - b. Wait on cement (WOC) time for a primary cement job will be a minimum of **8 hours** or **500 pounds compressive strength**, whichever is greater (including lead cement.)
  - c. Wait on cement (WOC) time for a remedial job will be a minimum of 4 hours after bringing cement to surface or 500 pounds compressive strength, whichever is greater.
  - d. If cement falls back, remedial cementing will be done prior to drilling out that string.

***1st Intermediate casing must be kept fluid filled to meet BLM minimum collapse requirement.***

2. The minimum required fill of cement behind the **10-3/4** inch intermediate casing is **cement to surface**. If cement does not circulate, see B.1.a, c-d above.
  - **Wait on cement (WOC) time for a primary cement job is to include the lead cement slurry** due to the presence of cave/karst, Capitan Reef, or potash features.

***2nd Intermediate casing must be kept fluid filled to meet BLM minimum collapse requirement.***

3. The minimum required fill of cement behind the **7-5/8** inch intermediate casing is **500 feet** into the previous casing.
  - **Wait on cement (WOC) time for a primary cement job is to include the lead cement slurry** due to the presence of cave/karst, Capitan Reef, or potash features.

**Bradenhead Squeeze:** Operator has proposed to cement in two stages by conventionally cementing the first stage and performing a bradenhead squeeze on the second stage, contingent upon no returns to surface.

- a. **First stage:** Operator will cement with intent to reach the top of the **Brushy Canyon**.
  - b. **Second stage:** Operator to squeeze and top-out. Cement to meet requirements listed for this casing string. If cement does not circulate see B.1.a, c-d above.
4. The minimum required fill of cement behind the **5-1/2** inch production casing is **500 feet** into the previous casing.
    - **Wait on cement (WOC) time for a primary cement job is to include the lead cement slurry** due to the presence of cave/karst, Capitan Reef, or potash features.

## **C. PRESSURE CONTROL**

1. Operator has proposed a multi-bowl wellhead assembly. Minimum working pressure of the blowout preventer (BOP) and related equipment (BOPE) required for drilling below the surface casing shoe shall be **5000 (5M) psi**. **Variance is approved to use a 5000 (5M) annular which shall be tested to 3500 (3.5M) psi**.
  - a. Wellhead shall be installed by manufacturer's representatives, submit documentation with subsequent sundry.
  - b. If the welding is performed by a third party, the manufacturer's representative shall monitor the temperature to verify that it does not exceed the maximum temperature of the seal.
  - c. Manufacturer representative shall install the test plug for the initial BOP test.

- d. If the cement does not circulate and one-inch operations would have been possible with a standard wellhead, the well head shall be cut off, cementing operations performed and another wellhead installed.
  - e. Whenever any seal subject to test pressure is broken, all the tests in 43 CFR 3172 must be followed.
2. Variance approved to use flex line from BOP to choke manifold. Manufacturer's specification to be readily available. No external damage to flex line. Flex line to be installed as straight as possible (no hard bends).
  3. Break testing has been approved for this well ONLY on those intervals utilizing a 5M BOPE or less. **(Annular preventer must be tested to a minimum of 70% of BOPE working pressure and shall be higher than the MASP.)** If in the event break testing is not utilized, then a full BOPE test would be conducted.
    - BOPE Break Testing is ONLY permitted for hole sections with 5M MASP or less.
    - If the MASP approaches 10% of the rated working pressure of a 5M system, the BOPE must be tested to 10M.
    - The break test should involve a shell test that includes testing the upper pipe rams as proposed.
    - Variance only pertains to the hole-sections in and shallower than the Wolfcamp formation. Break testing is NOT allowed when planning to penetrate the Penn group.
    - While in transfer between wells, the BOPE shall be secured by the hydraulic carrier or cradle in accordance with API STD 53.
    - Any well control event while drilling require notification to the BLM Petroleum Engineer.
    - A full BOPE test is required prior to drilling the first intermediate section.
    - If a hole section tends to show more background gas than normal, please notify BLM Engineer prior to proceeding with break testing on the next well.
    - The BLM PET is to be contacted 4 hours prior to BOPE tests.
      - *Eddy County Petroleum Engineering Inspection Staff: (575) 361-2822*
      - *Lea County Petroleum Engineering Inspection Staff: (575) 689-5981*
    - As a minimum, a full BOPE test shall be performed at 21-day intervals.
    - In the event any repairs or replacement of the BOPE is required, the BOPE shall test as per  
43 CFR 3172.

#### D. SPECIAL REQUIREMENT(S)

##### WIPP Requirements

The proposed surface well or bottom hole is located within 330 feet of the WIPP Land Withdrawal Area boundary. As a result, the operator is required to submit daily drilling reports, logs and

deviation survey information to the Bureau of Land Management Engineering Department and the U.S. Department of Energy per requirements of the Joint Powers Agreement until a total vertical depth of 7,000 feet is reached. These reports will have at a minimum, the depth of any excess mud returns (brine flows), the rate of penetration and a clearly marked section showing the deviation for each 500-foot interval. Operator may be required to do more frequent deviation surveys based on the daily information submitted and may be required to take other corrective measures. Information will also be provided to the New Mexico Oil Conservation Division after drilling activities have been completed. Upon completion of the well, the operator shall submit a complete directional survey. Any future entry into the well for purposes of completing additional drilling will require supplemental information.

Any oil and gas well operator drilling within one mile of the WIPP Boundary must notify WIPP as soon as possible if any of the following conditions are encountered during oil and gas operations: R-111-Q Amendment - Notification to Operators (Potash)

- a) Indication of any well collision event,
- b) Suspected well fluid flow (oil, gas, or produced water) outside of casing,
- c) Sustained annulus pressure between the 1st intermediate and next innermost casing string in excess of 500 psi above the baseline pressure of the well, or above 1500 psi total,
- d) Increasing pressure buildup rates (psi/day) across multiple successive bleed-off cycles on the annulus between the 1st intermediate and next innermost casing during well production, or
- e) Sustained losses in excess of 50% through the salt formation during drilling.

The operator can email the required information to [OilGasReports@wipp.ws](mailto:OilGasReports@wipp.ws). Attached files must not be greater than 20 MB. Call WIPP Tech Support at 575-234-7422, during the hours 7:00am to 4:30pm, if there are any issues sending to this address.

### **Unit Wells:**

The well sign for a unit well shall include the unit number in addition to the surface and bottom hole lease numbers. This also applies to participating area numbers. If a participating area has not been established, the operator can use the general unit designation but will replace the unit number with the participating area number when the sign is replaced.

### **Commercial Well Determination:**

A commercial well determination shall be submitted after production has been established for at least six months. **(This is not necessary for secondary recovery unit wells)**

### **Offline Cementing**

Offline cementing has been approved for **all hole sections**. Contact the BLM prior to the commencement of any offline cementing procedure.

## GENERAL REQUIREMENTS

The BLM is to be notified in advance for a representative to witness:

- a. Spudding well (minimum of 24 hours)
- b. Setting and/or Cementing of all casing strings (minimum of 4 hours)
- c. BOPE tests (minimum of 4 hours)

For multi-well pads, notifications for the following operations may be made together going from one well to the next. This does NOT apply to notifications for wells in the R111Q potash area:

- Casing run
- Offline cementing
- Break testing

### Contact Lea County Petroleum Engineering Inspection Staff:

Call the Hobbs Field Station, 414 West Taylor, Hobbs NM 88240, (575) 689-5981

### Contact Eddy County Petroleum Engineering Inspection Staff:

Email or call the Carlsbad Field Office, 620 East Greene St., Carlsbad, NM 88220; [BLM NM CFO DrillingNotifications@BLM.GOV](mailto:BLM_NM_CFO_DrillingNotifications@BLM.GOV); (575) 361-2822

1. Unless the production casing has been run and cemented or the well has been properly plugged, the drilling rig shall not be removed from over the hole without prior approval.
  - a. In the event the operator proposed to drill multiple wells utilizing a skid / walking rig. Operator shall secure the wellbore on the current well, after installing and testing the wellhead, by installing a blind flange of like pressure rating to the wellhead and a pressure gauge that can be monitored while drilling is performed on the other well(s).
  - b. When the operator proposes to set surface casing with Spudder Rig
    - i. Notify the BLM when moving in and removing the Spudder Rig.
    - ii. Notify the BLM when moving in the 2<sup>nd</sup> Rig. Rig to be moved in within 90 days of notification that Spudder Rig has left the location.
    - iii. BOP/BOPE test to be conducted per **43 CFR 3172** as soon as 2<sup>nd</sup> Rig is rigged up on swell.
2. Floor controls are required for 3M or Greater systems. These controls will be on the rig floor, unobstructed, readily accessible to the driller and will always be operational during drilling and/or completion activities. Rig floor is defined as the area immediately around the rotary table; the area immediately above the substructure on which the draw works are located, this does not include the doghouse or stairway area.

3. For intervals in which cement to surface is required, cement to surface should be verified with a visual check and density or pH check to differentiate cement from spacer and drilling mud. The results should be documented in the driller's log and daily reports.

#### A. CASING & CEMENT

1. The current acceptable methods of cement verification are as follows:
  - i. Observing cement circulated to surface,
  - ii. Cement Bond Log (CBL),
  - iii. Temperature log within 8-10 hours after completing the cement job,
  - iv. Echometer (if a second-stage bradenhead is being utilized and operator was granted approval prior to operations.)
2. Changes to the approved APD casing program need prior approval if the items substituted are of lesser grade or different casing size or are non-API. The Operator can exchange the components of the proposal with that of superior strength (i.e. changing from J-55 to N-80, or from 36# to 40#). Changes to the approved cement program need prior approval if the altered cement plan has less volume or strength or if the changes are substantial (i.e. Multistage tool, ECP, etc.). The initial wellhead installed on the well will remain on the well with spools used as needed.
3. Wait on cement (WOC) for Potash Areas: After cementing but before commencing any tests, the casing string shall stand cemented under pressure until both of the following conditions have been met: 1) cement reaches a minimum compressive strength of 500 psi for all cement blends of both lead and tail cement, 2) until cement has been in place at least 8 hours. WOC time will be recorded in the driller's log. The casing integrity test can be done (prior to the cement setting up) immediately after bumping the plug.
4. Wait on cement (WOC) for Water Basin: After cementing but before commencing any tests, the casing string shall stand cemented under pressure until both of the following conditions have been met: 1) cement reaches a minimum compressive strength of 500 psi at the shoe, 2) until cement has been in place at least 8 hours. WOC time will be recorded in the driller's log. See individual casing strings for details regarding lead cement slurry requirements. The casing integrity test can be done (prior to the cement setting up) immediately after bumping the plug.
5. Provide compressive strengths including hours to reach required 500 pounds compressive strength prior to cementing each casing string. Well specific cement details must be onsite prior to pumping the cement for each casing string.
6. No pea gravel permitted for remedial or fall back remedial without prior authorization from the BLM engineer.
7. On that portion of any well approved for a 5M BOPE system or greater, a pressure integrity test of each casing shoe shall be performed. Formation at the shoe shall be tested to a minimum of the mud weight equivalent anticipated to control the formation

- pressure to the next casing depth or at total depth of the well. This test shall be performed before drilling more than 20 feet of new hole.
8. If hard band drill pipe is rotated inside casing, returns will be monitored for metal. If metal is found in samples, drill pipe will be pulled and rubber protectors which have a larger diameter than the tool joints of the drill pipe will be installed prior to continuing drilling operations.
  9. Whenever a casing string is cemented in the R-111-Q potash area, the NMOCD requirements shall be followed.

## **B. PRESSURE CONTROL**

1. All blowout preventer (BOP) and related equipment (BOPE) shall comply with well control requirements as described in **43 CFR 3172**.
2. If a variance is approved for a flexible hose to be installed from the BOP to the choke manifold, the following requirements apply: The flex line must meet the requirements of API 16C. Check condition of flexible line from BOP to choke manifold, replace if exterior is damaged or if line fails test. Line to be as straight as possible with no hard bends and is to be anchored according to Manufacturer's requirements. The flexible hose can be exchanged with a hose of equal size and equal or greater pressure rating. Anchor requirements, specification sheet and hydrostatic pressure test certification matching the hose in service, to be onsite for review. These documents shall be posted in the company man's trailer and on the rig floor.
3. 5M or higher system requires an HCR valve, remote kill line and annular to match. The remote kill line is to be installed prior to testing the system and tested to stack pressure.
4. If the operator has proposed a multi-bowl wellhead assembly in the APD. The following requirements must be met:
  - i. Wellhead shall be installed by manufacturer's representatives, submit documentation with subsequent sundry.
  - ii. If the welding is performed by a third party, the manufacturer's representative shall monitor the temperature to verify that it does not exceed the maximum temperature of the seal.
  - iii. Manufacturer representative shall install the test plug for the initial BOP test.
  - iv. Whenever any seal subject to test pressure is broken, all the tests in 43 CFR 3172.6(b)(9) must be followed.
  - v. If the cement does not circulate and one-inch operations would have been possible with a standard wellhead, the well head shall be cut off, cementing operations performed and another wellhead installed.
5. The appropriate BLM office shall be notified a minimum of 4 hours in advance for a representative to witness the tests.

- i. In a water basin, for all casing strings utilizing slips, these are to be set as soon as the crew and rig are ready and any fallback cement remediation has been done. The casing cut-off and BOP installation can be initiated four hours after installing the slips, which will be approximately six hours after bumping the plug. For those casing strings not using slips, the minimum wait time before cut-off is eight hours after bumping the plug. BOP/BOPE testing can begin after cut-off or once cement reaches 500 psi compressive strength (including lead cement), whichever is greater. However, if the float does not hold, cut-off cannot be initiated until cement reaches 500 psi compressive strength (including lead when specified).
- ii. In potash areas, for all casing strings utilizing slips, these are to be set as soon as the crew and rig are ready and any fallback cement remediation has been done. For all casing strings, casing cut-off and BOP installation can be initiated at twelve hours after bumping the cement plug. The BOPE test can be initiated after bumping the cement plug with the casing valve open. (This only applies to single stage cement jobs, prior to the cement setting up.)
- iii. The tests shall be done by an independent service company utilizing a test plug not a cup or J-packer and can be initiated immediately with the casing valve open. The operator also has the option of utilizing an independent tester to test without a plug (i.e. against the casing) pursuant to **43 CFR 3172** with the pressure not to exceed 70% of the burst rating for the casing. Any test against the casing must meet the WOC time for 8 hours or 500 pounds compressive strength, whichever is greater, prior to initiating the test (see casing segment as lead cement may be critical item).
- iv. The test shall be run on a 5000-psi chart for a 2-3M BOP/BOP, on a 10000-psi chart for a 5M BOP/BOPE and on a 15000-psi chart for a 10M BOP/BOPE. If a linear chart is used, it shall be a one-hour chart. A circular chart shall have a maximum 2-hour clock. If a twelve hour or twenty-four-hour chart is used, tester shall make a notation that it is run with a two -our clock.
- v. The results of the test shall be reported to the appropriate BLM office.
- vi. All tests are required to be recorded on a calibrated test chart. A copy of the BOP/BOPE test chart and a copy of independent service company test will be submitted to the appropriate BLM office.
- vii. The BOP/BOPE test shall include a low-pressure test from 250 to 300 psi. The test will be held for a minimum of 10 minutes if test is done with a test plug and 30 minutes without a test plug. This test shall be performed prior to the test at full stack pressure.
- viii. BOP/BOPE must be tested by an independent service company within 500 feet of the top of the Wolfcamp formation if the time between the setting of the

intermediate casing and reaching this depth exceeds 20 days. This test does not exclude the test prior to drilling out the casing shoe as per **43 CFR 3172**.

**C. DRILLING MUD**

Mud system monitoring equipment, with derrick floor indicators and visual and audio alarms, shall be operating before drilling into the Wolfcamp formation, and shall be used until production casing is run and cemented.

**D. WASTE MATERIAL AND FLUIDS**

All waste (i.e. drilling fluids, trash, salts, chemicals, sewage, gray water, etc.) created because of drilling operations and completion operations shall be safely contained and disposed of properly at a waste disposal facility. No waste material or fluid shall be disposed of on the well location or surrounding area. Porto-johns and trash containers will be on-location during fracturing operations or any other crew-intensive operations.

KEITH IMMATTY 4/9/2026



# API BTC -Special Clearance

Coupling	Pipe Body
Grade: J55 (Casing)	Grade: J55 (Casing)
Body: Bright Green	1st Band: Bright Green
1st Band: White	2nd Band: -
2nd Band: -	3rd Band: -
3rd Band: -	4th Band: -

Outside Diameter	10.750 in.	Wall Thickness	0.350 in.	Grade	J55 (Casing)
Min. Wall Thickness	87.50 %	Pipe Body Drift	API Standard	Type	Casing
Connection OD Option	Special Clearance				

## Pipe Body Data

Geometry			Performance		
Nominal OD	10.750 in.	Drift	9.894 in.	SMYS	55,000 psi
Wall Thickness	0.350 in.	Plain End Weight	38.91 lb/ft	Min UTS	75,000 psi
Nominal Weight	40.500 lb/ft	OD Tolerance	API	Body Yield Strength	629 x1000 lb
Nominal ID	10.050 in.			Min. Internal Yield Pressure	3130 psi
				Collapse Pressure	1580 psi
				Max. Allowed Bending	23 °/100 ft

## Connection Data

Geometry		Performance	
Thread per In	5	Joint Strength	700 x1000 lb
Connection OD	11.250 in.	Coupling Face Load	329 x1000 lb
Hand Tight Stand Off	1 in.	Internal Pressure Capacity	3130 psi

## Notes

For products according to API Standards 5CT & 5B; Performance calculated considering API Technical Report 5C3 (Sections 9 & 10) equations. For geometrical and steel grades combinations not considered in the API Standards 5CT and/or 5B; Performance calculations indirectly derived from API Technical Report 5C3 (Sections 9 & 10) equations. Couplings OD are shown according to current API 5CT 10th Edition.

Tenaris has issued this document for general information only, and the information in this document, including, without limitation, any pictures, drawings or designs ("Information") is not intended to constitute professional or any other type of advice or recommendation and is provided on an "as is" basis. No warranty is given. Tenaris has not independently verified any information—if any—provided by the user in connection with, or for the purpose of, the Information contained hereunder. The use of the Information is at user's own risk and Tenaris does not assume any responsibility or liability of any kind for any loss, damage or injury resulting from, or in connection with any Information contained hereunder or any use thereof. The Information in this document is subject to change or modification without notice. Tenaris's products and services are subject to Tenaris's standard terms and conditions or otherwise to the terms resulting from the respective contracts of sale or services, as the case may be, between petitioner and Tenaris. For more complete information please contact a Tenaris's representative or visit our website at [www.tenaris.com](http://www.tenaris.com). ©Tenaris 2025. All rights reserved.

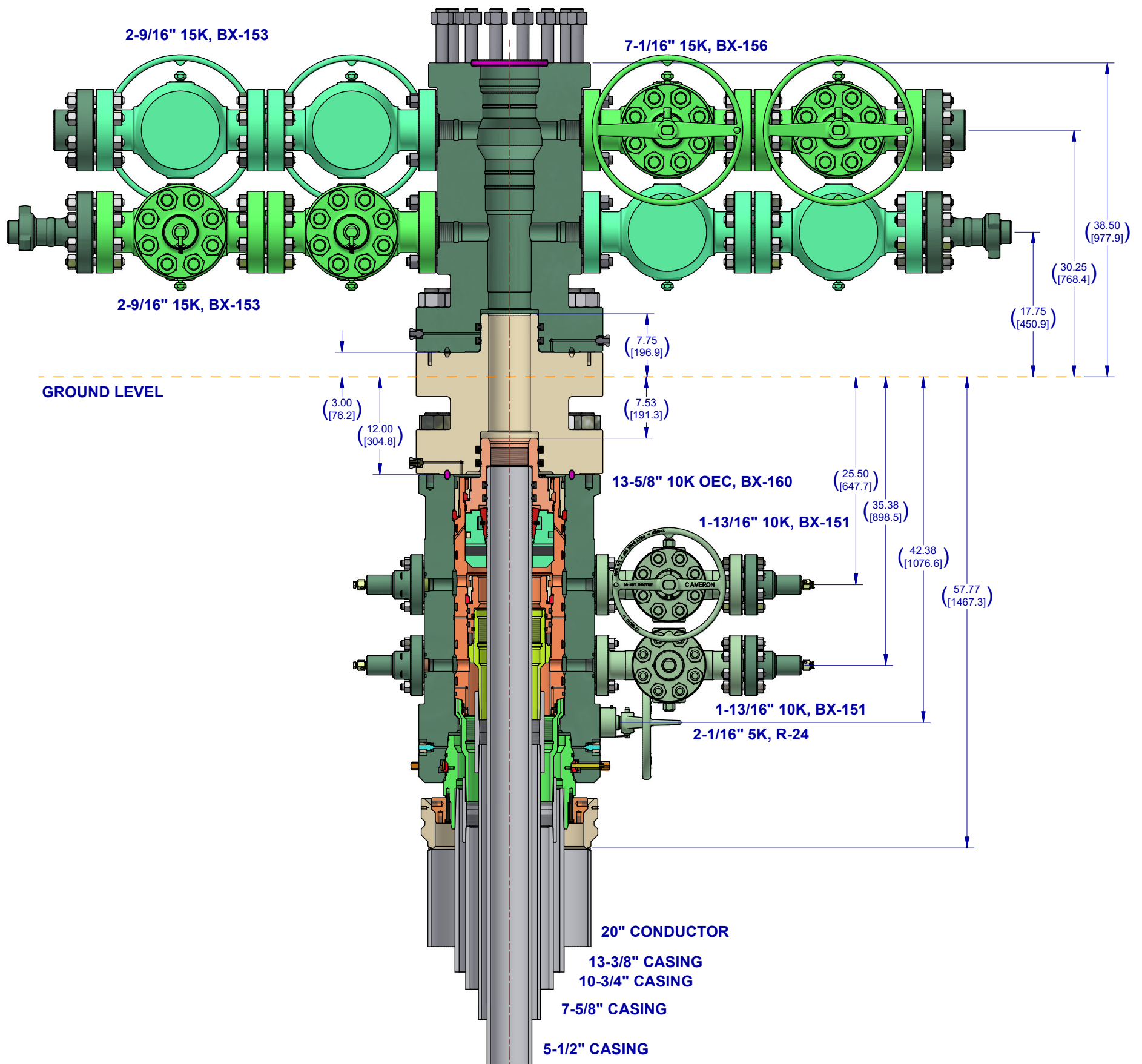

**Notes:**

1. THIS IS A PROPOSAL DRAWING AND DIMENSIONS SHOWN ARE SUBJECT TO CHANGE DURING THE FINAL DESIGN PROCESS.

2. DIGITALLY ENABLED SOLUTIONS, CHOKES AND ESD'S AVAILABLE ON REQUEST

CONFIDENTIAL				
SURFACE TREATMENT	DO NOT SCALE		 An SLB company	SURFACE SYSTEMS
DRAWN BY: D. GOTTUNG	DATE 20 Aug 25	CHECKED BY: D. GOTTUNG		
MATERIAL & HEAT TREAT	APPROVED BY: D. GOTTUNG		OXY WT SPOOLTREE	
ESTIMATED WEIGHT: 16383.5 LBS 7431.4 KG	INITIAL USE BM: EWR: 650687960	SHEET 1 of 1	SD-053434-277-25	
			REV: 01	INVENTOR: B

# Oxy USA Inc. - Blanket Design Pad Document

## OXY - Blanket Design B

Pad Name: LSTTNK\_22S31E\_26\_2

SHL: 2448' FSL 2111' FEL, Sec 26, T22S-R31E

Oxy requests for the bellow wells to be approved for the two designs listed in the Blanket Design document (**Blanket Design B –OXY –4S Slim v4.0.**) The MDs and TVDs for all intervals are within the boundary conditions. The max inclination and DLS are also within the boundary conditions (directional plans attached separately for review.)

### 1. Blanket Design - Wells

Well Name	APD #	Surface		Salt		Intermediate		Production	
		MD	TVD	MD	TVD	MD	TVD	MD	TVD
OLIVE WON UNIT 74H	10400096406	913	913	4434	4434	10233	10233	18911	10835
OLIVE WON UNIT 73H	10400096405	913	913	4430	4430	10090	10090	18813	10820
OLIVE WON UNIT 22H	10400096931	913	913	4429	4429	9711	9711	18395	10370
OLIVE WON UNIT 23H	10400096933	913	913	4431	4431	9685	9685	18386	10375
OLIVE WON UNIT 2H	10400096928	913	913	4429	4429	9223	9223	17905	9770
OLIVE WON UNIT 3H	10400096402	913	913	4430	4430	9049	9049	17774	9780

### 2. Review Criteria Table

	Y or N
Is casing new? If used, attach certification as required in 43 CFR 3160	Y
Does casing meet API specifications? If no, attach casing specification sheet.	Y
Is premium or uncommon casing planned? If yes attach casing specification sheet.	Y
Does the above casing design meet or exceed BLM's minimum standards? If not provide justification (loading assumptions, casing design criteria).	Y
Will the intermediate pipe be kept at a minimum 1/3 fluid filled to avoid approaching the collapse pressure rating of the casing?	Y
Is well located within Capitan Reef?	N
If yes, does production casing cement tie back a minimum of 50' above the Reef?	
Is well within the designated 4 string boundary.	
Is well located in SOPA but not in R-111-Q?	Y
If yes, are the first 2 strings cemented to surface and 3 <sup>rd</sup> string cement tied back 500' into previous casing?	Y
Is well located in R-111-Q and SOPA?	N
If yes, are the first three strings cemented to surface?	
Is 2 <sup>nd</sup> string set 100' to 600' below the base of salt?	
Is well located in high Cave/Karst?	N
If yes, are there two strings cemented to surface?	
(For 2 string wells) If yes, is there a contingency casing if lost circulation occurs?	
Is well located in critical Cave/Karst?	N
If yes, are there three strings cemented to surface?	

### 3. Geologic Formations

Formation	MD-RKB (ft)	TVD-RKB (ft)	Expected Fluids
Rustler	843	843	
Salado	1126	1126	Salt
Marker Bed 126	2000	2000	Salt
Castile	3020	3020	Salt
Delaware	4434	4434	Oil/Gas/Brine
Bell Canyon	4481	4481	Oil/Gas/Brine
Cherry Canyon	5347	5343	Oil/Gas/Brine
Brushy Canyon	6591	6560	Losses
Bone Spring	8419	8348	Oil/Gas
Bone Spring 1st	9580	9483	Oil/Gas
Bone Spring 2nd	10139	10030	Oil/Gas
Bone Spring 3rd			Oil/Gas
Wolfcamp			Oil/Gas
Penn			Oil/Gas
Strawn			Oil/Gas

### 4. Cementing Program

Section	Stage	Slurry:	Sacks	Yield (ft <sup>3</sup> /ft)	Density (lb/gal)	Excess:	TOC	Placement	Description
Surface	1	Surface - Tail	954	1.33	14.8	100%	-	Circulate	Class C+Accel.
Int.1	1	Intermediate - Tail	85	1.33	14.8	20%	3,934	Circulate	Class C+Accel.
Int.1	1	Intermediate - Lead	618	1.73	12.9	50%	-	Circulate	Class Pozz+Ret.
Int. 2	1	Intermediate 1S - Tail	455	1.68	13.2	5%	6,841	Circulate	Class C+Ret., Disper.
Int. 2	2	Intermediate 2S - Tail BH	984	1.71	13.3	25%	-	Bradenhead	Class C+Accel.
Prod.	1	Production - Tail	520	1.84	13.3	25%	9,733	Circulate	Class C+Ret.

# Oxy USA Inc. - OLIVE WON UNIT 2H Drill Plan

## 1. Geologic Formations

TVD of Target (ft):	9770	Pilot Hole Depth (ft):	
Total Measured Depth (ft):	17905	Deepest Expected Fresh Water (ft):	843

### Delaware Basin

Formation	MD-RKB (ft)	TVD-RKB (ft)	Expected Fluids
Rustler	843	843	
Salado	1132	1132	Salt
Marker Bed 126	2000	2000	Salt
Castile	3024	3024	Salt
Delaware	4429	4429	Oil/Gas/Brine
Bell Canyon	4480	4480	Oil/Gas/Brine
Cherry Canyon	5429	5413	Oil/Gas/Brine
Brushy Canyon	6604	6542	Losses
Bone Spring	8447	8314	Oil/Gas
Bone Spring 1st	9646	9460	Oil/Gas
Bone Spring 2nd			Oil/Gas
Bone Spring 3rd			Oil/Gas
Wolfcamp			Oil/Gas
Penn			Oil/Gas
Strawn			Oil/Gas

\*H2S, water flows, loss of circulation, abnormal pressures, etc.

## 2. Casing Program

Section	Hole Size (in)	MD		TVD		Csg. OD (in)	Csg Wt. (ppf)	Grade	Conn.
		From (ft)	To (ft)	From (ft)	To (ft)				
Surface	17.5	0	913	0	913	13.375	54.5	J-55	BTC
Salt	12.25	0	4429	0	4429	10.75	40.5	J-55	BTC-SC
Intermediate	9.875	0	9223	0	9223	7.625	26.4	L-80 HC	BTC
Production	6.75	0	17905	0	9770	5.5	20	P-110	DWC/C-HT-IS

All casing strings will be tested in accordance with 43 CFR part 3170 Subpart 3172

\*Oxy requests the option to run the 10.75" Intermediate I as a contingency string to be run only if severe hole conditions dictate an additional casing string necessary. This would make the planned 7.625" / 7.827" Casing the Intermediate II.  
 \*\*If 4S Contingency is not required, Oxy requests permission to transition from 12.25" to 9.875" Intermediate I at 1st trip point below Brushy top (estimated top in formation table above). Cement volumes will be updated on C103 submission.

<i>All Casing SF Values will meet or exceed those below</i>			
<b>SF Collapse</b>	<b>SF Burst</b>	<b>Body SF Tension</b>	<b>Joint SF Tension</b>
1.00	1.100	1.4	1.4

**Annular Clearance Variance Request**

As per the agreement reached in the Oxy/BLM face-to-face meeting on Feb 22, 2018, Oxy requests permission to allow deviation from the 0.422" annular clearance requirement. Please see Annular Clearance Variance attachment for further details.

	Y or N
Is casing new? If used, attach certification as required in 43 CFR 3160	Y
Does casing meet API specifications? If no, attach casing specification sheet.	Y
Is premium or uncommon casing planned? If yes attach casing specification sheet.	Y
Does the above casing design meet or exceed BLM's minimum standards? If not provide justification (loading assumptions, casing design criteria).	Y
Will the intermediate pipe be kept at a minimum 1/3 fluid filled to avoid approaching the collapse pressure rating of the casing?	Y
<b>Is well located within Capitan Reef?</b>	
If yes, does production casing cement tie back a minimum of 50' above the Reef?	N
Is well within the designated 4 string boundary.	
<b>Is well located in SOPA but not in R-111-Q?</b>	
If yes, are the first 2 strings cemented to surface and 3 <sup>rd</sup> string cement tied back 500' into previous casing?	Y
<b>Is well located in R-111-Q and SOPA?</b>	
If yes, are the first three strings cemented to surface?	N
Is 2 <sup>nd</sup> string set 100' to 600' below the base of salt?	
<b>Is well located in high Cave/Karst?</b>	
If yes, are there two strings cemented to surface?	N
(For 2 string wells) If yes, is there a contingency casing if lost circulation occurs?	
<b>Is well located in critical Cave/Karst?</b>	
If yes, are there three strings cemented to surface?	N

### 3. Cementing Program

Section	Stage	Slurry:	Sacks	Yield (ft <sup>3</sup> /ft)	Density (lb/gal)	Excess:	TOC	Placement	Description
Surface	1	Surface - Tail	954	1.33	14.8	100%	-	Circulate	Class C+Accel.
Int.1	1	Intermediate - Tail	85	1.33	14.8	20%	3,929	Circulate	Class C+Accel.
Int.1	1	Intermediate - Lead	618	1.73	12.9	50%	-	Circulate	Class Pozz+Ret.
Int. 2	1	Intermediate 1S - Tail	318	1.68	13.2	5%	6,854	Circulate	Class C+Ret., Disper.
Int. 2	2	Intermediate 2S - Tail BH	986	1.71	13.3	25%	-	Bradenhead	Class C+Accel.
Prod.	1	Production - Tail	520	1.84	13.3	25%	8,723	Circulate	Class C+Ret.

#### Offline Cementing Request

Oxy requests a variance to cement the 9.625" and/or 7.625" intermediate casing strings offline in accordance to the approved variance, EC Tran 461365. Please see Offline Cementing Variance attachment for further details.

#### Bradenhead CBL Request

Oxy requests permission to adjust the CBL requirement after bradenhead cement jobs, on 7-5/8" intermediate casings, as per the agreement reached in the OXY/BLM meeting on September 5, 2019. Please see Bradenhead CBL Variance attachment for further details.

**4. Pressure Control Equipment**

BOP installed and tested before drilling which hole?	Size?	Min. Required WP	Type	✓	Tested to:	TVD Depth (ft) per Section:
12.25" Hole	13-5/8"	5M	Annular	✓	70% of working pressure	4429
		5M	Blind Ram	✓	250 psi / 5000 psi	
			Pipe Ram			
			Double Ram	✓		
			Other*			
9.875" Hole	13-5/8"	5M	Annular	✓	70% of working pressure	9223
		5M	Blind Ram	✓	250 psi / 5000 psi	
			Pipe Ram			
			Double Ram	✓		
			Other*			
6.75" Hole	13-5/8"	5M	Annular	✓	70% of working pressure	9770
		5M	Blind Ram	✓	250 psi / 5000 psi	
			Pipe Ram			
			Double Ram	✓		
			Other*			

\*Specify if additional ram is utilized

BOP/BOPE will be tested by an independent service company to 250 psi low and the high pressure indicated above per 43 CFR part 3170 Subpart 3172 requirements. The System may be upgraded to a higher pressure but still tested to the working pressure listed in the table above. If the system is upgraded all the components installed will be functional and tested.

Pipe rams will be operationally checked each 24 hour period. Blind rams will be operationally checked on each trip out of the hole. These checks will be noted on the daily tour sheets. Other accessories to the BOP equipment will include a Kelly cock and floor safety valve (inside BOP) and choke lines and choke manifold.

	<p>Formation integrity test will be performed per 43 CFR part 3170 Subpart 3172. On Exploratory wells or on that portion of any well approved for a 5M BOPE system or greater, a pressure integrity test of each casing shoe shall be performed. Will be tested in accordance with 43 CFR part 3170 Subpart 3172.</p>
	<p>A variance is requested for the use of a flexible choke line from the BOP to Choke Manifold. See attached for specs and hydrostatic test chart.</p>
<p>Y</p>	<p>Are anchors required by manufacturer?</p>
	<p>A multibowl or a unionized multibowl wellhead system will be employed. The wellhead and connection to the BOPE will meet all API 6A requirements. The BOP will be tested per 43 CFR part 3170 Subpart 3172 after installation on the surface casing which will cover testing requirements for a maximum of 30 days. If any seal subject to test pressure is broken the system must be tested. We will test the flange connection of the wellhead with a test port that is directly in the flange. We are proposing that we will run the wellhead through the rotary prior to cementing surface casing as discussed with the BLM on October 8, 2015.</p> <p>See attached schematics.</p>

**BOP Break Testing Request**

Oxy requests permission to adjust the BOP break testing (intermediate and production) requirements as per the agreement reached in the OXY/BLM meeting on April 4th, 2025. Please see BOP Break Testing Variance attachment for further details.

**Oxy will use Cameron ADAPT wellhead system that uses an OEC top flange connection. This connection has been fully vetted and verified by API to Spec 6A and carries an API monogram.**

### 5. Mud Program

Section	Depth		Depth - TVD		Type	Weight (ppg)	Viscosity	Water Loss
	From (ft)	To (ft)	From (ft)	To (ft)				
Surface	0	913	0	913	Water-Based Mud	8.6 - 8.8	40-60	N/C
Intermediate 1	913	4429	913	4429	Saturated Brine-Based or Oil-Based Mud	8.0 - 10.0	35-45	N/C
Intermediate 2	4429	9223	4429	9223	Water-Based or Oil-Based Mud	8.0 - 10.0	38-50	N/C
Production	9223	17905	9223	9770	Water-Based or Oil-Based Mud	8.0 - 8.5	38-50	N/C

Sufficient mud materials to maintain mud properties and meet minimum lost circulation and weight increase requirements will be kept on location at all times. The following is a general list of products: Barite, Bentonite, Gypsum, Lime, Soda Ash, Caustic Soda, Nut Plug, Cedar Fiber, Cotton Seed Hulls, Drilling Paper, Salt Water Clay, ACL2. Oxy will use a closed mud system.

What will be used to monitor the loss or gain of fluid?	PVT/MD Totco/Visual Monitoring
---	--------------------------------

### 6. Logging and Testing Procedures

Logging, Coring and Testing.	
Yes	Will run GR from TD to surface (horizontal well – vertical portion of hole). Stated logs run will be in the Completion Report and submitted to the BLM.
No	Logs are planned based on well control or offset log information.
No	Drill stem test? If yes, explain
No	Coring? If yes, explain
Additional logs planned	Interval
No	Resistivity
No	Density
Yes	CBL Production string
Yes	Mud log Bone Spring – TD
No	PEX

**7. Drilling Conditions**

Condition	Specify what type and where?
BH Pressure at deepest TVD	4319 psi
Abnormal Temperature	No
BH Temperature at deepest TVD	159°F

Pump high viscosity sweeps as needed for hole cleaning. The mud system will be monitored visually/manually as well as with an electronic PVT. The necessary mud products for additional weight and fluid loss control will be on location at all times. Appropriately weighted mud will be used to isolate potential gas, oil, and water zones until such time as casing can be cemented into place for zonal

Hydrogen Sulfide (H2S) monitors will be installed prior to drilling out the surface shoe. If H2S is detected in concentrations greater than 100 ppm, the operator will comply with the provisions of 43 CFR part 3170 Subpart 3172. If Hydrogen Sulfide is encountered, measured values and formations will be provided to the BLM.	
N	H2S is present
Y	H2S Plan attached

**8. Other facets of operation**

	Yes/No
Will the well be drilled with a walking/skidding operation? If yes, describe. We plan to drill the 6 well pad in batch by section: all surface sections, intermediate sections and production sections. The wellhead will be secured with a night cap whenever the rig is not over the well.	Yes
Will more than one drilling rig be used for drilling operations? If yes, describe. Oxy requests the option to contract a Surface Rig to drill, set surface casing, and cement for this well. If the timing between rigs is such that Oxy would not be able to preset surface, the Primary Rig will MIRU and drill the well in its entirety per the APD. Please see the attached document for information on the spudder rig.	Yes

**Total Estimated Cuttings Volume: 1623 bbls**

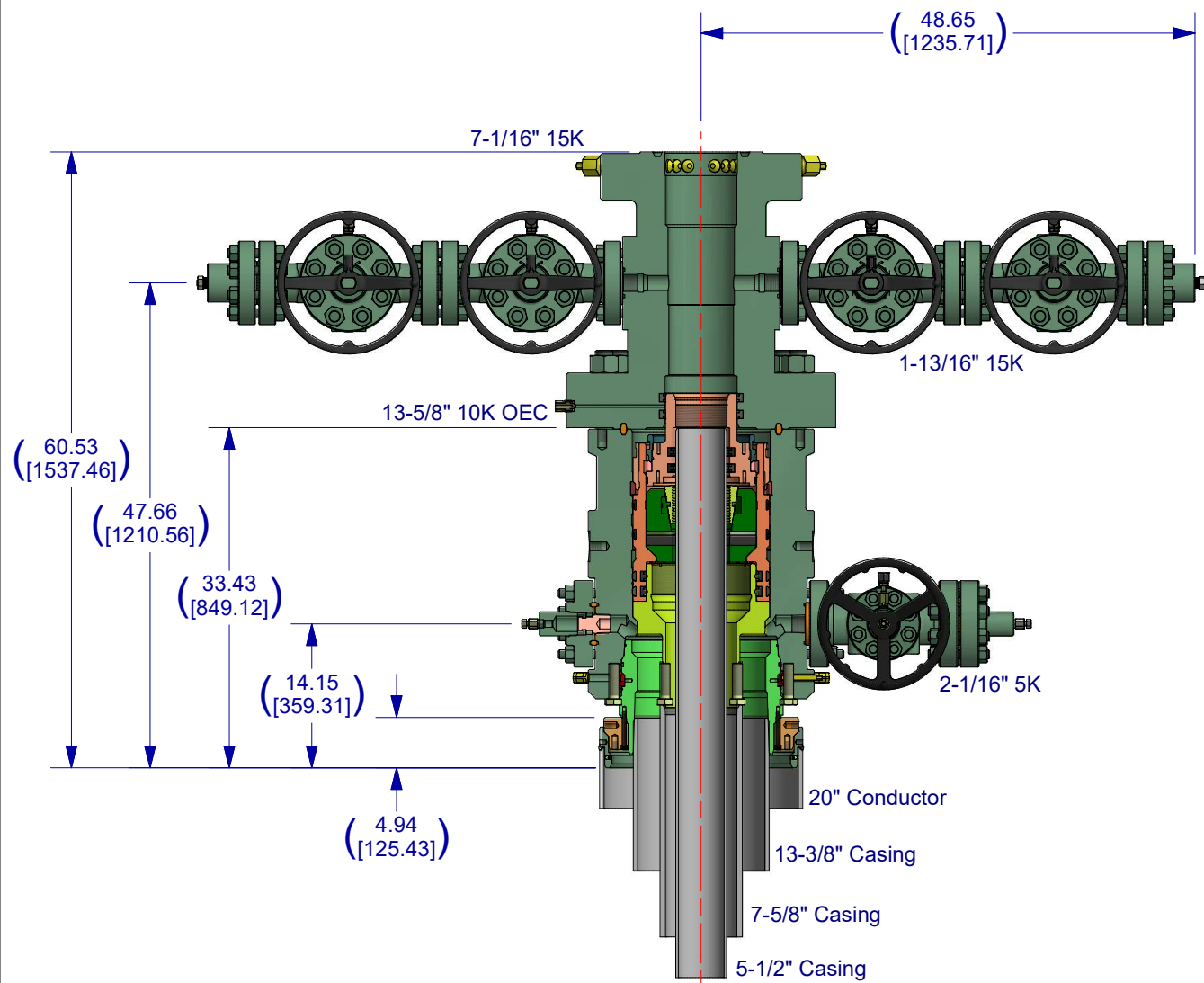

**VIEW SHOWING LOWER OUTLETS**

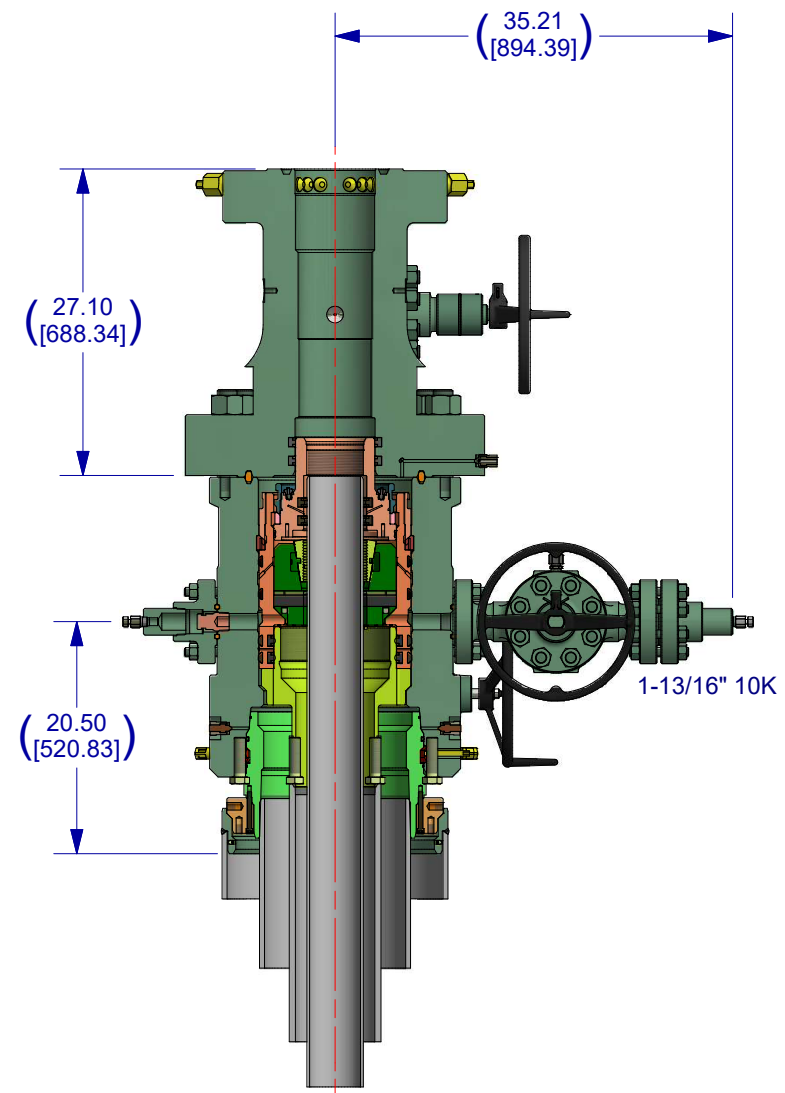

**VIEW SHOWING UPPER OUTLETS**

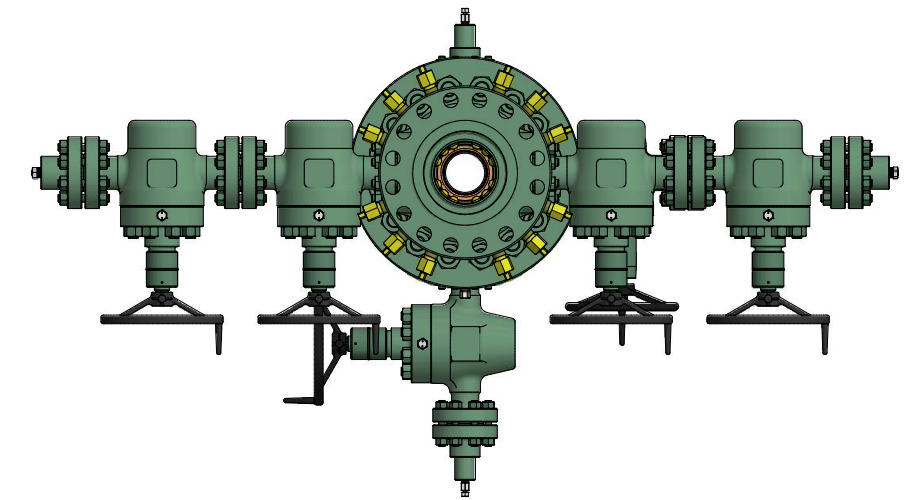

**TOP VIEW**

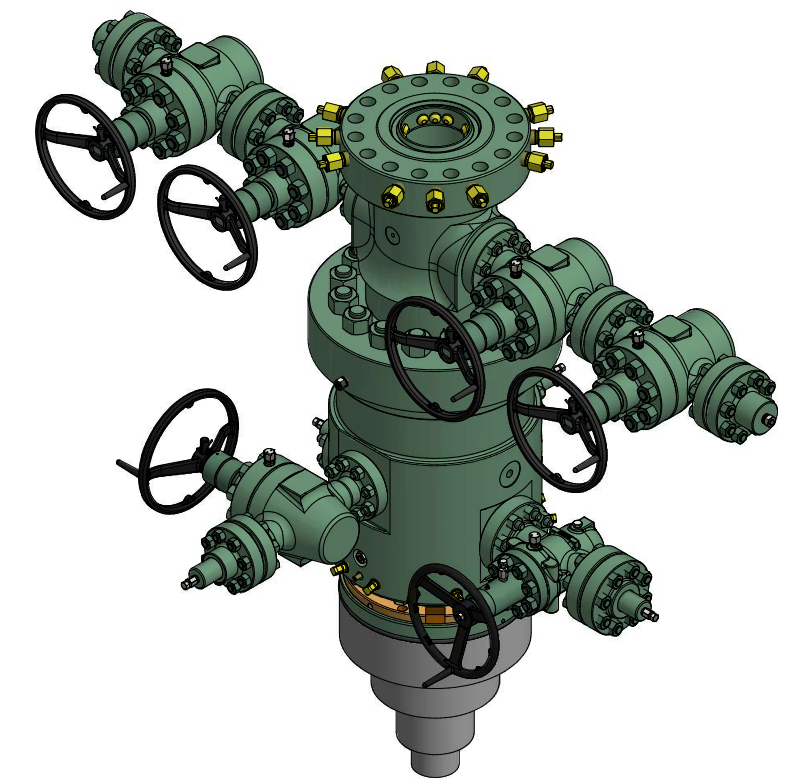

**ISOMETRIC VIEW**

**NOTE:** This is a proposal drawing and dimensions shown are subject to change during the final design process.

<b>CAMERON CONFIDENTIAL INFORMATION</b>			
<b>DO NOT SCALE</b>		 A Schlumberger Company	SURFACE SYSTEMS
DRAWN BY: <b>C. LOPEZ</b>	DATE: <b>01/21/2022</b>		
CHECKED BY: <b>M. MORGAN</b>	DATE: <b>01/21/2022</b>	<b>13-5/8" 10K 'OEC ADAPT-NST' WELLHEAD</b>	
DRAWING NO: <b>QD-06-00095</b>	REV: <b>01</b>		

# Oxy Combined Variances - Table of Contents

5MAnnBOPVariance.pdf .....	2
BOPBreakTestingVariance2026.pdf .....	6
BradenheadCBLVariance.pdf .....	7
FalconSL1AnnClearanceVariance.pdf .....	8
ProdCsgAnnClearanceVariance.pdf .....	9
OfflineIntermediateCementVariance.pdf .....	10
Oxy-BLM Offline Production Cementing rev2.pdf .....	13
SpudRigData.pdf .....	24

## 5M Annular BOP Variance Request

Per BLM's Memorandum No. NM-2017-008: *Decision and Rationale for a Variance Allowing the Use of a 5M Annular Preventer with a 10M BOP Stack*, Oxy requests to employ a 5M annular with a 10M BOPE stack in the pilot and lateral sections of the well and will ensure that two barriers to flow are maintained at all times. Please see Well Control Plan below.

### Oxy Well Control Plan

#### A. Component and Preventer Compatibility Table

The table below, which covers the drilling and casing of the >5M MASP portion of the well, outlines the tubulars and the compatible preventers in use. This table, combined with the mud program, documents that two barriers to flow can be maintained at all times, independent of the rating of the annular preventer.

Pilot hole and Lateral sections, 10M requirement

Component	OD	Preventer	RWP
Drillpipe	4-1/2"-5"	Lower 3-1/2 - 5-1/2" VBR Upper 3-1/2 - 5-1/2" VBR	10M
HWDP	4-1/2"-5"	Lower 3-1/2 - 5-1/2" VBR Upper 3-1/2 - 5-1/2" VBR	10M
Drill collars and MWD tools	4-3/4" – 5-1/2"	Lower 3-1/2 - 5-1/2" VBR Upper 3-1/2 - 5-1/2" VBR	10M
Mud Motor	4-3/4"	Lower 3-1/2 - 5-1/2" VBR Upper 3-1/2 - 5-1/2" VBR	10M
Production casing	5-1/2"	Lower 3-1/2 - 5-1/2" VBR Upper 3-1/2 - 5-1/2" VBR	10M
ALL	0" - 13-5/8"	Annular	5M
Open-hole	6-3/4"	Blind Rams	10M

VBR = Variable Bore Ram. Compatible range listed in chart.

HWDP = Heavy Weight Drill Pipe

MWD = Measurement While Drilling

#### B. Well Control Procedures

Well control procedures are specific to the rig equipment and the operation at the time the kick occurs. Below are the minimal high-level tasks prescribed to assure a proper shut-in while drilling, tripping, running casing, pipe out of the hole (open hole), and moving the Bottom Hole Assembly (BHA) through the Blowout Preventers (BOP). The pressure at which control is swapped from the annular to another compatible ram will occur when the anticipated pressure is approaching or envisioned to exceed 70% of the 5M annular Rated Working Pressure (RWP) or 3500 PSI.

#### General Procedure While Drilling

1. Sound alarm (alert crew)
2. Space out drill string
3. Shut down pumps (stop pumps and rotary)
4. Shut-in Well (uppermost applicable BOP, typically annular preventer first. The Hydraulic Control Remote (HCR) valve and choke will already be in the closed position).
5. Confirm shut-in
6. Notify tool pusher/company representative
7. Read and record the following:
  - a. SIDPP and SICP
  - b. Pit gain
  - c. Time
8. Regroup and identify forward plan
9. If pressure has built or expected to reach 70% of the annular RWP during kill operations, crew will reconfirm spacing and swap to the upper pipe ram

#### General Procedure While Tripping

1. Sound alarm (alert crew)
2. Stab full opening safety valve and close
3. Space out drill string
4. Shut-in (uppermost applicable BOP, typically annular preventer first. The HCR and choke will already be in the closed position)
5. Confirm shut-in
6. Notify tool pusher/company representative
7. Read and record the following
  - a. SIDPP and SICP
  - b. Pit gain
  - c. Time
  - d. Regroup and identify forward plan
  - e. If pressure has built or is anticipated during the kill to reach the RWP of the annular preventer, confirm spacing and swap to the upper pipe ram

#### General Procedure While Running Casing

1. Sound alarm (alert crew)
2. Stab crossover and full opening safety valve and close
3. Space out string
4. Shut-in (uppermost applicable BOP, typically annular preventer first. The HCR and choke will already be in the closed position).
5. Confirm shut-in
6. Notify tool pusher/company representative
7. Read and record the following:
  - a. SIDPP and SICP
  - b. Pit gain
  - c. Time
  - d. Regroup and identify forward plan.
  - e. If pressure has built or is anticipated during the kill to reach the RWP of the annular preventer, confirm spacing and swap to compatible pipe ram.

General Procedure With No Pipe In Hole (Open Hole)

1. Sound alarm (alert crew)
2. Shut-in with blind rams or BSR. (The HCR and choke will already be in the closed position)
3. Confirm shut-in
4. Notify tool pusher/company representative
5. Read and record the following:
  - a. SICP
  - b. Pit gain
  - c. Time
6. Regroup and identify forward plan

General Procedures While Pulling BHA thru Stack

1. PRIOR to pulling last joint of drill pipe thru the stack.
  - a. Perform flow check, if flowing:
  - b. Sound alarm (alert crew)
  - c. Stab full opening safety valve and close
  - d. Space out drill string with tool joint just beneath the upper pipe ram
  - e. Shut-in using upper pipe ram. (The HCR and choke will already be in the closed position)
  - f. Confirm shut-in
  - g. Notify tool pusher/company representative
  - h. Read and record the following:
    - i. SIDPP and SICP
    - ii. Pit gain
    - iii. Time
    - iv. Regroup and identify forward plan
2. With BHA in the stack and compatible ram preventer and pipe combo immediately available.
  - a. Sound alarm (alert crew)
  - b. Stab crossover and full opening safety valve and close
  - c. Space out drill string with upset just beneath the compatible pipe ram
  - d. Shut-in using compatible pipe ram. (The HCR and choke will already be in the closed position.)
  - e. Confirm shut-in
  - f. Notify tool pusher/company representative
  - g. Read and record the following:
    - i. SIDPP and SICP
    - ii. Pit gain
    - iii. Time
    - iv. Regroup and identify forward plan
3. With BHA in the stack and NO compatible ram preventer and pipe combo immediately available.

- a. Sound alarm (alert crew)
- b. If possible to pick up high enough, pull string clear of the stack and follow “Open Hole” scenario
- c. If impossible to pick up high enough to pull the string clear of the stack
- d. Stab crossover, make up one joint/stand of drill pipe, and full opening safety valve and close
- e. Space out drill string with tool joint just beneath the upper pipe ram
- f. Shut-in using upper pipe ram. (The HCR and choke will already be in the closed position)
- g. Confirm shut-in
- h. Notify tool pusher/company representative
- i. Read and record the following:
  - i. SIDPP and SICP
  - ii. Pit gain
  - iii. Time
- j. Regroup and identify forward plan

## BOP Break Testing Request

Oxy requests permission to adjust the BOP break testing requirements as per the agreement reached with OXY/BLM on January 22nd, 2026.

BOPE Break Testing is ONLY permitted for 5M MASP or less on wells that are in the Wolfcamp formation or shallower. If the MASP approaches 10% of the rated working pressure of a 5M system, the BOPE must be tested to 10M and annular to 5M.

BOP break test for the **intermediate or production** section under the following conditions:

- After a full BOP test is conducted.
- When skidding to drill an intermediate or production section which does not penetrate the deeper than the Wolfcamp formation ( $\leq 5M$  MASP).
- In the event any repairs or replacement of the BOPE is required, the BOPE shall test as per 3 CFR part 3170 Subpart 3172
- While in transfer between wells, the BOPE shall be secured by the hydraulic carrier or cradle.
- In the event break testing is not utilized, then a full BOPE test would be conducted.
- If the kill line is broken prior to skid, two tests will be performed.
  - 1) Wellhead flange, co-flex hose, kill line connections and upper pipe rams
  - 2) Wellhead flange, HCR valve, check valve, upper pipe rams
- If the kill line is not broken prior to skid, only one test will be performed.
  - 1) Wellhead flange, co-flex hose, check valve, upper pipe rams

## **Bradenhead Cement CBL Variance Request**

Oxy requests permission to adjust the CBL requirement after bradenhead cement jobs, on 7-5/8” intermediate casings, as per the agreement reached in the OXY/BLM meeting on September 5, 2019.

### **Three string wells:**

- CBL will be required on one well per pad
- If the pumped volume of cement is less than permitted in the APD, BLM will be notified and a CBL may be run
- Echometer will be used after bradenhead cement job to determine TOC before pumping top-out cement

### **Four string wells:**

- CBL is not required
- If the pumped volume of cement is less than permitted in the APD, BLM will be notified and a CBL may be run
- Echometer will be used after bradenhead cement job to determine TOC before pumping top-out cement

## **Falcon SL1 Production Casing Annular Clearance Variance Request**

If Production Casing Connection OD does not meet 0.422" annular clearance inside casing:

- Cement excess will be circulated from Top of Liner to surface (Cement Confirmation)
- Liner Top will be tested to confirm seal.
- If ICP in Bone Spring Pool and lateral landed in Wolfcamp Pool, a CBL will be ran.

## **Production Casing Annular Clearance Variance Request**

As per the agreement reached in the Oxy/BLM face-to-face meeting on Feb 22, 2018, Oxy requests permission to allow deviation from the 0.422" annular clearance requirement from 43 CFR part 3170 Subpart 3172 under the following conditions:

1. Annular clearance to meet or exceed 0.422" between intermediate casing ID and production casing coupling only on the first 500' overlap between both casings.
2. Annular clearance less than 0.422" is acceptable for the curve and lateral portions of the production open hole section.

## Offline Intermediate Cementing Variance Request

Oxy requests a variance to cement the 9.625” and/or 7.625” intermediate casing strings offline in accordance to the approved variance, EC Tran 461365.

### 1. Cement Program

No changes to the cement program will take place for offline cementing.

### 2. Offline Cementing Procedure

The operational sequence will be as follows:

1. Run casing as per normal operations. While running casing, conduct negative pressure test and confirm integrity of the float equipment (float collar and shoe)
2. Land casing with mandrel
3. Fill pipe with kill weight fluid, do not circulate through floats and confirm well is static
4. Set annular packoff shown below and pressure test to confirm integrity of the seal.  
Pressure ratings of wellhead components and valves is 5,000 psi

Annular packoff with both external and internal seals

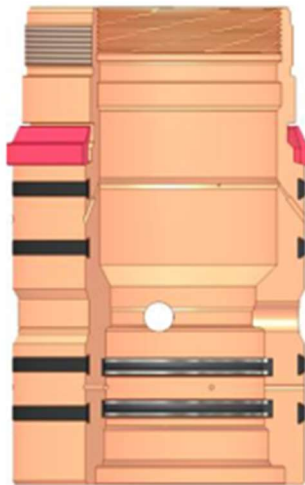

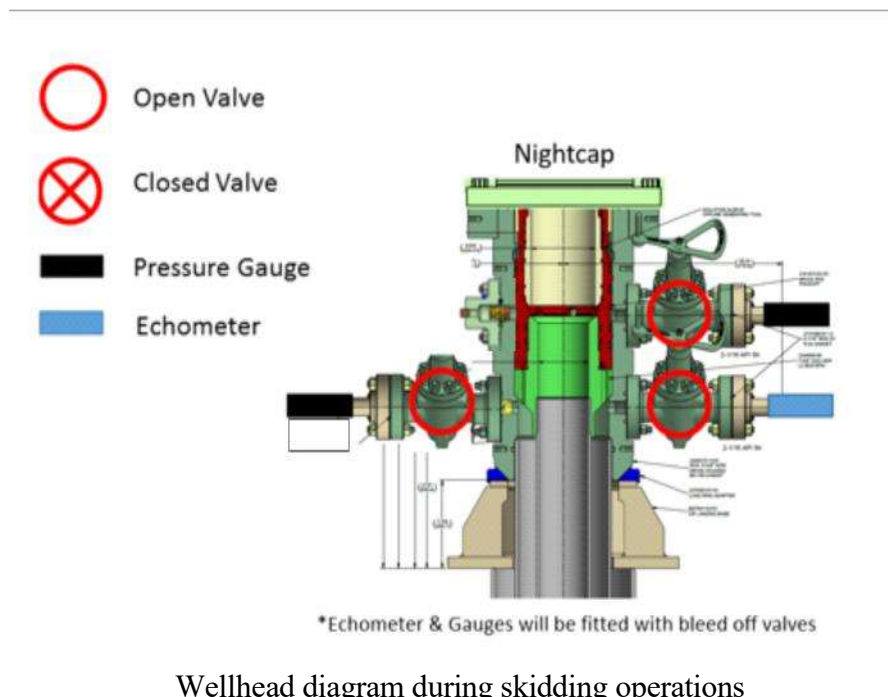

5. After confirmation of both annular barriers and internal barriers, nipple down BOP and install cap flange.
  - a. If any barrier fails to test, the BOP stack will not be nipped down until after the cement job is completed with cement 500ft above the highest formation capable of flow with kill weight mud above or after it has achieved 50 psi compressive strength if cannot be verified.
6. Skid rig to next well on pad.
7. Confirm well is static before removing cap flange, flange will not be removed and offline cementing operations will not commence until well is under control. If well is not static, casing outlet valves will provide access to both the casing ID and annulus. Rig or third party pump truck will kill well prior to cementing or nipping up for further remediation.
  - a. Well Control Plan
    - i. The Drillers Method will be the primary well control method to regain control of the wellbore prior to cementing, if wellbore conditions do not permit the drillers method other methods of well control may be used
    - ii. Rig pumps or a 3<sup>rd</sup> party pump will be tied into the upper casing valve to pump down the casing ID
    - iii. A high pressure return line will be rigged up to lower casing valve and run to choke manifold to control annular pressure
    - iv. Once influx is circulated out of the hole, kill weight mud will be circulated
    - v. Well will be confirmed static
    - vi. Once confirmed static, cap flange will be removed to allow for offline cementing operations to commence
8. Install offline cement tool
9. Rig up cement equipment

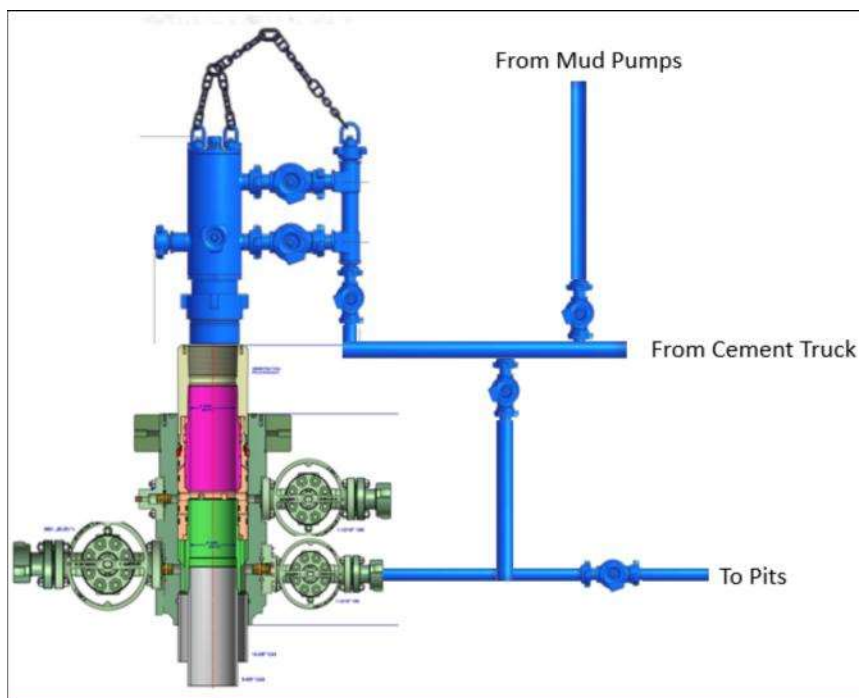

Wellhead diagram during offline cementing operations

10. Circulate bottoms up with cement truck
  - a. If gas is present on bottoms up, well will be shut in and returns rerouted through gas buster to handle entrained gas
  - b. Max anticipated time before circulating with cement truck is 6 hrs
11. Perform cement job taking returns from the annulus wellhead valve
12. Confirm well is static and floats are holding after cement job
13. Remove cement equipment, offline cement tools and install night cap with pressure gauge for monitoring.



# OXY – OFFLINE PRODUCTION CEMENTING

SAFETY & EFFICIENCY

---

Oxy NM Team

12/22/25

LEAD WITH PASSION • OUTPERFORM EXPECTATIONS • DELIVER RESULTS RESPONSIBLY • UNLEASH OPPORTUNITIES • COMMIT TO GOOD

# BACKGROUND

- Oxy has successfully pumped hundreds of offline intermediate jobs (both deep/salts) since 2018
  - Single stage, two stage, bradenheads
- Why not productions?
  - Typically set production casing on slips, no ability to cement offline
  - Recently swapped to mandrel/packoffs on production
- Historical success
  - TX group cemented over 120+ production sections offline without issues. No well control incidents. Same wellhead provider as NM.
- Big Rig Well control certification
  - 2 x OXY DSM IADC supervisor level well control training
  - 2 x Rig manager IADC supervisor level well control training
  - 2 x driller IADC Driller level well control training
  - 1 x Oxy Field Superintendent IADC supervisor level well control training



# INITIAL OFFLINE CHECKLIST

- All items must be met, if not job will be performed online
  1. Offline production cement jobs must be at or above Wolfcamp formation
  2. Nothing out of the ordinary observed during drilling, tripping or casing running operations in the production hole section
  3. Casing must be landed out on hanger
  4. Oxy Company man with well control certification must be present to monitor returns
  5. Rig manager is responsible for walking rig to next well
  6. BOP will **NOT** be nipped down if
    1. Any barrier fails to test
    2. Any offset frac operations are observed within 1 mile and in the same producing interval
  7. Oxy will not drill out next well until cement operations are concluded on offline portion



# PROCEDURE

- Run casing as per standard ops. Confirm well is candidate via checklist. Conduct negative pressure test while running casing and confirm integrity of the float equipment.
  - Float equipment has 2 x 15K valves
- Land production casing on mandrel hanger
  - If casing is unable to be landed with a mandrel hanger, casing will be cemented online.
  - If utilizing a fluted/ported mandrel hanger, ensure well is static on the annulus and inside the casing by filling the pipe with kill weight fluid, remove landing joint, and set annular packoff rated to 10,000 psi. Pressure test same to 10,000 psi
  - If utilizing a solid mandrel hanger, ensure well is static on the annulus and inside the casing by filling the pipe with kill weight fluid. Pressure test seals to 10,000 psi. Remove landing joint.
- Install back pressure valve in the casing for a 3rd casing barrier.
  - Back pressure valve rated to a minimum of 10,000 psi.
- With the well Secured; nipple down BOP and secure on hydraulic carrier or cradle and Skid/Walk rig to next well on pad.
  - If any of the barriers fail to test, the BOP stack will not be nipped down until after the cement job has concluded.
  - b. Oxy Company Man/Field supt. will oversee Cementing Operations while Rig Manager walks the rig and nipples up the BOP.
  - c. Oxy will not drill out of the subsequent well until after plug bump.



# PROCEDURE CONT.

- Install 15M Gate Valve, with wellhead adapter.
  - This creates an additional barrier on the annulus and inside the casing.
  - Gate valve rated to a minimum of 15,000 psi.
- Test connection between wellhead adapter seals against hanger neck and ring gasket to 10,000 psi.
- Remove backpressure valve from the casing.
- Rig up cement head and cementing lines.
- Perform cement job.
- Procedure continued on next page.



# PROCEDURE CONT.

- If an influx is noted during the Cement Job:
  - It is the Company Man and field Supt. responsibility to maintain well control. Driller/rig manager will divert to offline operations and assist.
  - The manifold will redirect flow to the rig's chokes.
  - Backpressure will be held on the well with the chokes to ensure well control is maintained through the remainder of the cement job while circulating out the influx.
  - If annular surface pressure approaches 90% tested pressure of the manifold or if circulating the influx out with the cementing pumps is not feasible, the well can be secured by closing the casing valves (10M).
  - Once cement is in place, we will close the casing valves and confirm the well is static and floats are holding.
  - If the floats fail, the gate valve (15M) or cement head (10M) can be closed to secure the well.
- Confirm well is static and floats are holding after cement job.
- Remove cement head.
- Install back pressure valve.
- Remove 15M Gate Valve and Wellhead Adapter.
- Install night cap with pressure gauge for monitoring.
- Test night cap to 10,000 psi



# WELLHEAD SCHEMATIC

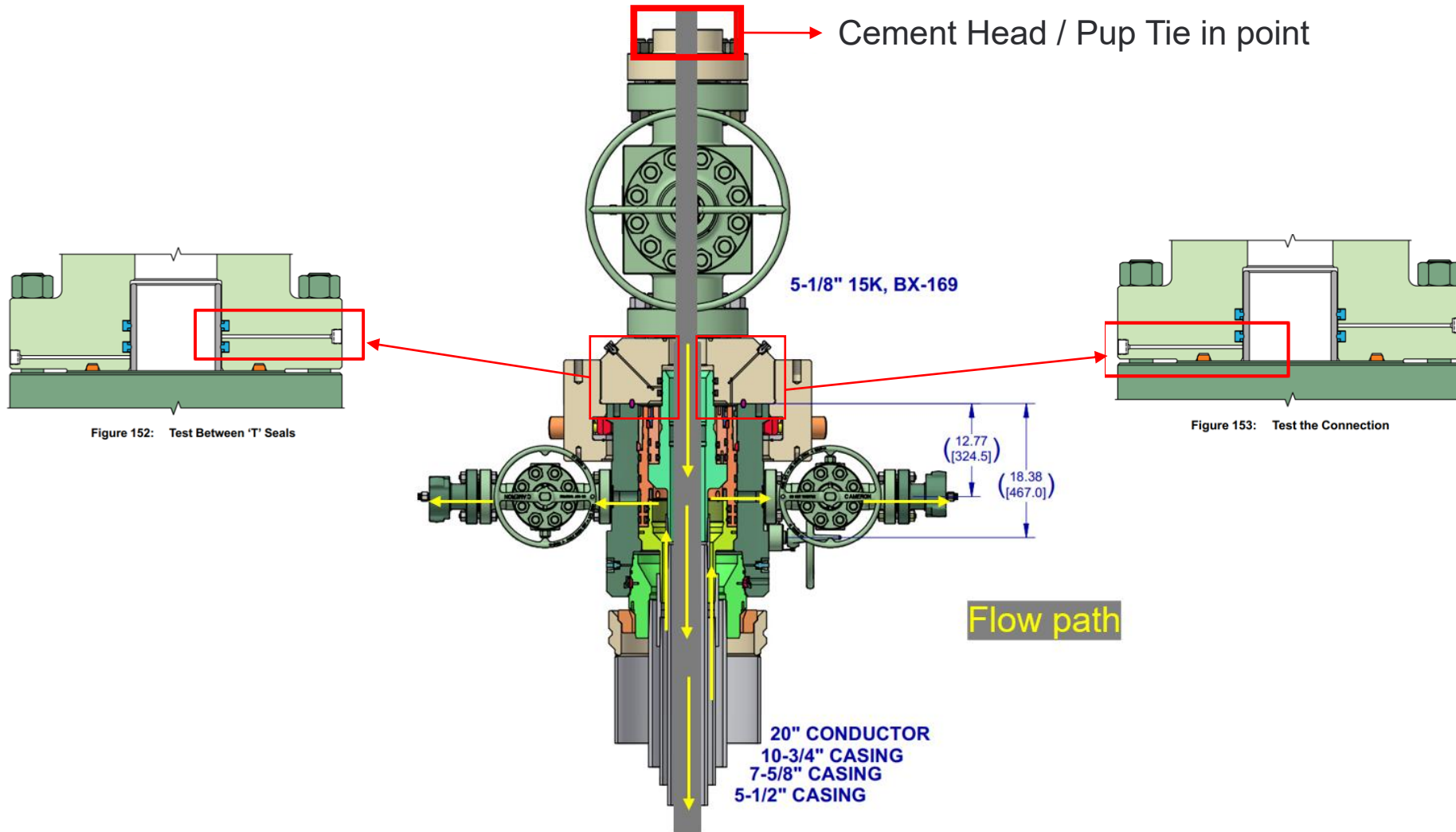

# CASING BARRIERS – ONLINE VS OFFLINE

Operation	Online	Offline
<b>Install Cement Head</b>	1. Hydrostatic Barrier 2. Float Valves	1. Hydrostatic Barrier 2. Float Valves 3. 15M Gate Valve
<b>Cement Job</b>	1. Hydrostatic Barrier 2. Float Valves 3. Cement Head	1. Hydrostatic Barrier 2. Float Valves 3. 15M Gate Valve 4. Cement Head
<b>Remove Cement Head</b>	1. Float Valves	1. Float Valves 2. 15M Gate Valve
<b>Install BPV &amp; Nipple down BOP/ Offline Adapter</b>	1. Float Valves 2. BPV	1. Float Valves 2. BPV
<b>Nipple up TA Cap</b>	1. Float Valves 2. BPV	1. Float Valves 2. BPV



# BARRIERS

## Barriers: During Removal of BOP

Operation	Casing	Annulus
<b>Nippling Down BOP</b>	1. BPV 2. Hydrostatic Barrier 3. Float Valves	1. Hydrostatic Barrier 2. Mechanical 10M Packoff

## Barriers: During Offline Cementing of Production Casing

Operation	Casing	Annulus
<b>Pull BPV</b>	1. Hydrostatic Barrier 2. Float Valves 3. 15M Gate Valve	1. Hydrostatic Barrier 2. Mechanical Packoff 3. 10M Wellhead Adapter
<b>Install Cement Head</b>	1. Hydrostatic Barrier 2. Float Valves 3. 15M Gate Valve	1. Hydrostatic Barrier 2. Mechanical 10M Packoff 3. 10M Wellhead Adapter
<b>Cement Job</b>	1. Float Valves 2. 15M Gate Valve 3. Cement Head	1. Hydrostatic Barrier 2. Mechanical 10M Packoff 3. 10M Wellhead Adapter
<b>Remove Cement Head</b>	1. Float Valves 2. 15M Gate Valve	1. Hydrostatic Barrier 2. Mechanical 10M Packoff 3. 10M Wellhead Adapter
<b>Install BPV</b>	1. Float Valves 2. 15M Gate Valve	1. Hydrostatic Barrier 2. Mechanical 10M Packoff 3. 10M Wellhead Adapter
<b>Remove 10M Gate Valve</b>	1. Float Valves 2. BPV	1. Hydrostatic Barrier 2. Mechanical 10M Packoff
<b>Nipple up TA Cap</b>	1. Float Valves 2. BPV	1. Hydrostatic Barrier 2. Mechanical 10M Packoff



# RIG UP: TRADITIONAL METHOD - ONLINE

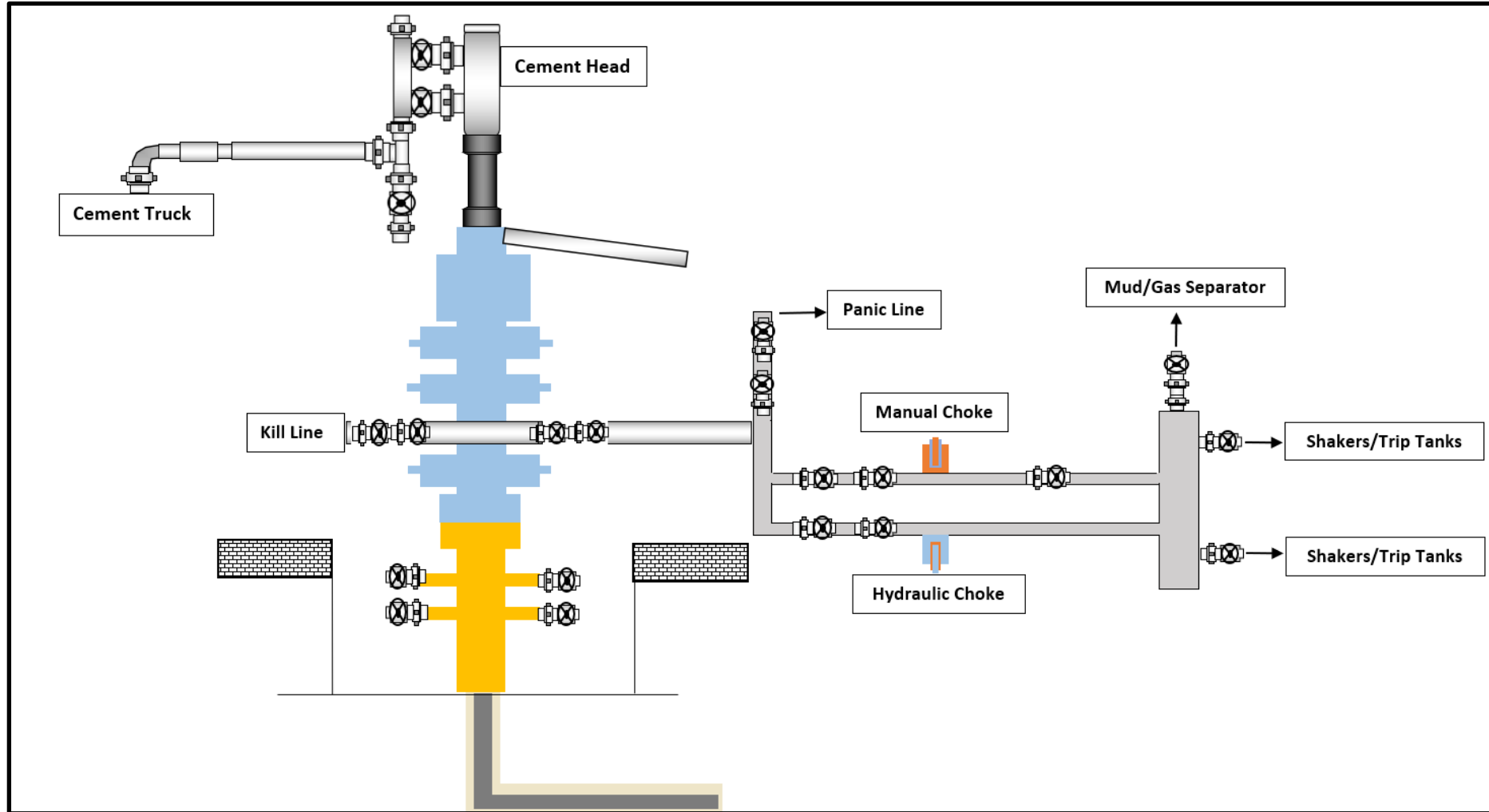

# RIG UP: PROPOSED METHOD - OFFLINE

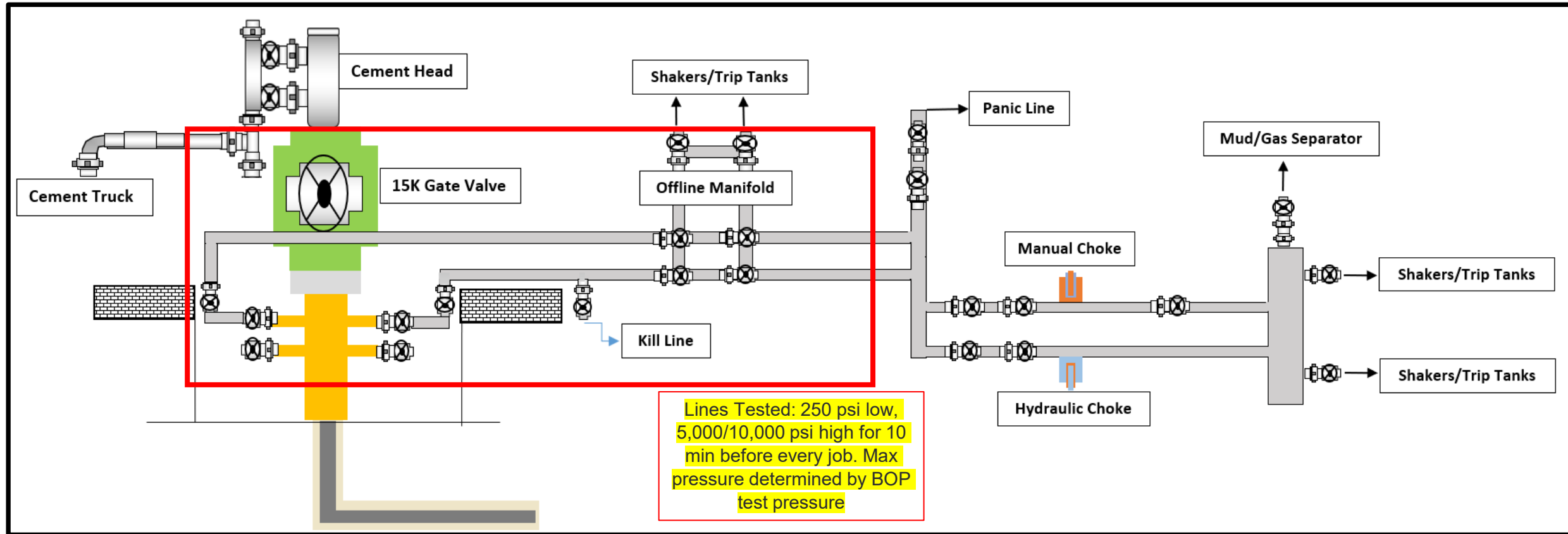

- Same well control capabilities as online
- Gate valve offers flexibility

**OXY USA Inc**  
**APD ATTACHMENT: SPUDDER RIG DATA**

**OPERATOR NAME / NUMBER:** OXY USA Inc

**1. SUMMARY OF REQUEST:**

Oxy USA respectfully requests approval for the following operations for the surface hole in the drill plan:

1. Utilize a spudder rig to pre-set surface casing for time and cost savings.

**2. Description of Operations**

1. Spudder rig will move in to drill the surface hole and pre-set surface casing on the well.
  - a. After drilling the surface hole section, the spudder rig will run casing and cement following all of the applicable rules and regulations (43 CFR part 3170 Subpart 3172, all COAs and NMOCD regulations).
  - b. The spudder rig will utilize fresh water-based mud to drill the surface hole to TD. Solids control will be handled entirely on a closed loop basis. No earth pits will be used.
2. The wellhead will be installed and tested as soon as the surface casing is cut off and the WOC time has been reached.
3. A blind flange at the same pressure rating as the wellhead will be installed to seal the wellbore. Pressure will be monitored with needle valves installed on two wingvalves.
  - a. A means for intervention will be maintained while the drilling rig is not over the well.
4. Spudder rig operations are expected to take 2-3 days per well on the pad.
5. The BLM will be contacted and notified 24 hours prior to commencing spudder rig operations.
6. Drilling operations will begin with a larger rig and a BOP stack equal to or greater than the pressure rating that was permitted will be nipped up and tested on the wellhead before drilling operations resume on each well.
  - a. The larger rig will move back onto the location within 90 days from the point at which the wells are secured and the spudder rig is moved off location.
  - b. The BLM will be contacted / notified 24 hours before the larger rig moves back on the pre-set locations.
7. Oxy will have supervision on the rig to ensure compliance with all BLM and NMOCD regulations and to oversee operations.
8. Once the rig is removed, Oxy will secure the wellhead area by placing a guard rail around the cellar area.

# Spudder Rig Layout

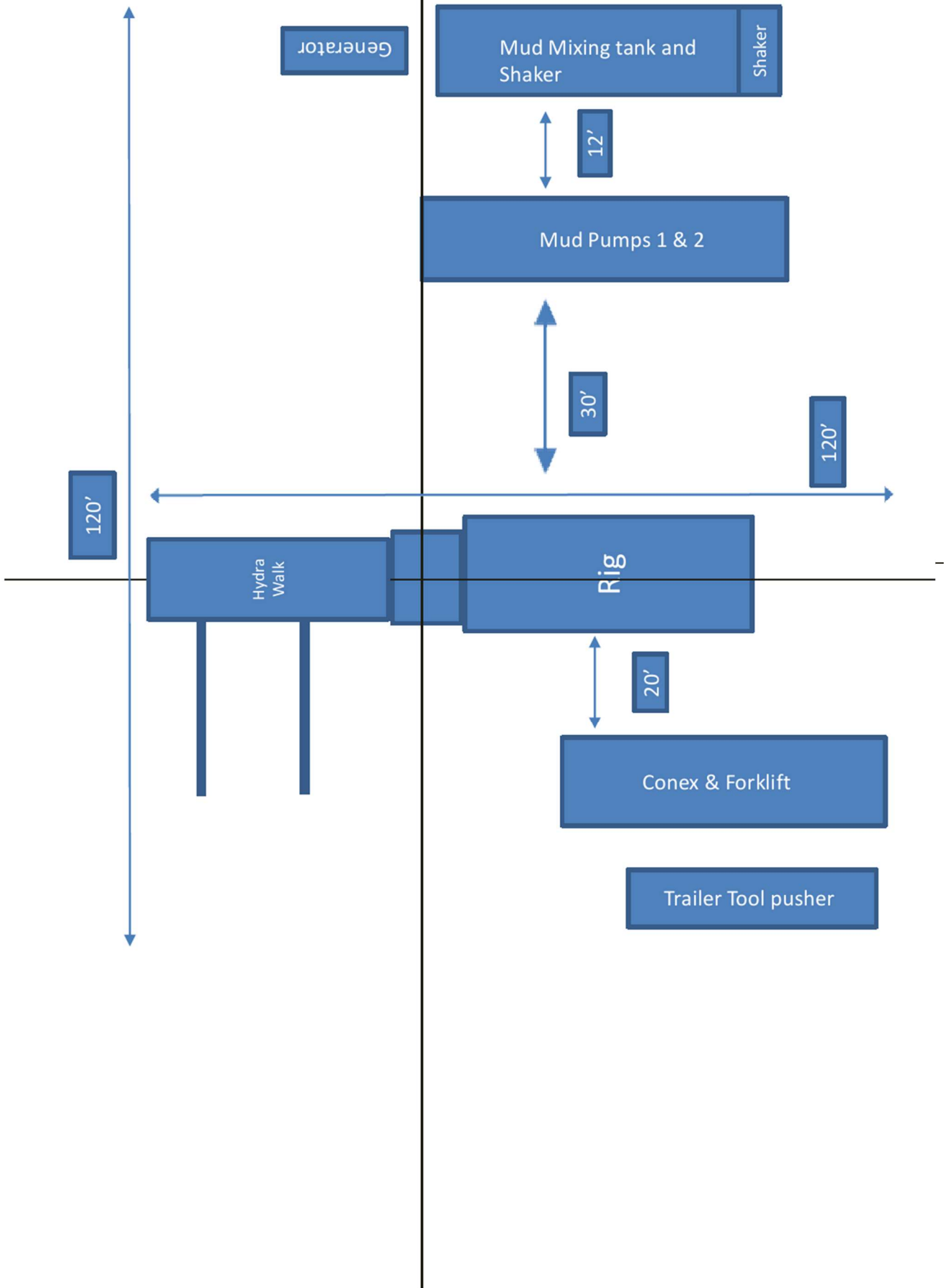



# Oxy Blanket Design - Casing Design "B"



## 1. Casing Program

The designs and associated details listed in this document are the "worst case scenario" boundaries for design safety factors.

Location and lithology have NOT been accounted for in these designs; however, the designs are NOT valid for wells within KPLA Boundaries or Capitan Reef areas. The specific well details will be based on the APD/Sundry package and the information listed in the COA.

The mud program listed below will remain the same between each design variation.

Hole will be full during casing run for well control and tensile SF.

Casing will be kept at least half full during run for these designs to meet BLM collapse SF requirement.

Section	Hole Size (in)	MD		TVD		Csg. OD (in)	Csg Wt. (ppf)	Grade	Conn.
		From (ft)	To (ft)	From (ft)	To (ft)				
Surface	17.5	0	1200	0	1200	13.375	54.5	J-55	BTC
Intermediate 1	12.25 <sup>†</sup>	0	4832	0	4832	10.75	40.5	J-55	BTC-SC
Intermediate 2	9.875	0	13111*	0	12775*	7.625	26.4	L-80 HC	BTC Axis-HT
Production	6.75	0	23361	0	12775	5.5	20	P-110	Wedge 461 Sprint SF DWC/C-HT-IS Sprint-TC SC

\*Curve could be in intermediate or production section

<sup>†</sup>Oxy requests the option to set intermediate 1 casing shallower, yet still below the salts, if required due to losses or hole conditions. Cement volumes may be adjusted if casing is set shallower and a DV tool may be run incase hole conditions merit pumping a second stage cement job to comply with the permitted top of cement. If cement is circulated to surface during first stage, Oxy will drop a cancelation cone and not pump the second stage. Well specific depths for the pad will be included with the casing setting depths information submitted for review.

All casing strings will be tested in accordance with 43 CFR part 3170 Subpart 3172.

<i>All Casing SF Values will meet or exceed those below</i>			
SF Collapse	SF Burst	Body SF Tension	Joint SF Tension
1.00	1.100	1.4	1.4

### §Annular Clearance Variance Request

As per the agreement reached in the Oxy/BLM face-to-face meeting on Feb 22, 2018, Oxy requests permission to allow deviation from the 0.422" annular clearance requirement. Please see Annular Clearance Variance attachment for further details.

§Annular Clearance Variance Request may not apply to all connections used or presented.



## Oxy Blanket Design - Casing Design "B"



### 2. Trajectory / Boundary Conditions

Section	MD		TVD		Max. Angle	Max. Planned DLS
	Deepest KOP (ft)	End Build (ft)	Deepest KOP (ft)	End Build (ft)		
Surface	0	1200	0	1200	5°	1°/100 ft
Salt	0	4832	0	4832	5°	1°/100 ft
Intermediate	5000 (inside Cherry Canyon)	6500	4980	6390	20°	2°/100 ft
	12211	13111	12202	12775	92° ‡	12°/100 ft ‡
Production	12211 (~100' MD past ICP)	13111	12202	12775	92° ‡	12°/100 ft ‡

‡ Applies only when intermediate casing depth is deepened to landing point to match TVD of production in some areas where required to accommodate higher MWs in depleted areas.

Oxy has reviewed casing burst, collapse, and axial loadcases in Landmark StressCheck with the boundary conditions in the table above which satisfies Oxy and BLM minimum design criteria. Triaxial plots for each casing string is shown in Section 7 and intermediate load case inputs are shown in Section 8.

### 3. Cementing Program

NOTE: Blanket design is for technical review only. The cement volumes will be adjusted to ensure cement tops meet BLM requirements.

Section	Stage	Slurry:	Sacks	Yield (ft <sup>3</sup> /ft)	Density (lb/gal)	Excess:	TOC	Placement	Description
Surface	1	Surface - Tail	1253	1.33	14.8	100%	-	Circulate	Class C+Accel.
Int.1	1	Intermediate - Tail	85	1.33	14.8	20%	4,332	Circulate	Class C+Accel.
Int.1	1	Intermediate - Lead	676	1.73	12.9	50%	-	Circulate	Class Pozz+Ret.
Int. 2	1	Intermediate 1S - Tail	793	1.68	13.2	5%	7,206	Circulate	Class C+Ret., Disper.
Int. 2	2	Intermediate 2S - Tail BH	1002	1.71	13.3	25%	-	Bradenhead	Class C+Accel.
Prod.	1	Production - Tail	609	1.84	13.3	25%	12,611	Circulate	Class C+Ret.
Prod.	2*	Production - Tail	TBD	1.84	13.3	50%	500' inside prev case	Circulate	Class C+Ret.

\*Only applies in scenario where planned single stage job TOC is not 500' above previous shoe as designed/programmed requiring bradenhead 2nd stage to meet requirements

As Reviewed and Approved by BLM on Feb 8, 2024: Oxy uses a Class C / Pozzolan mix on its production cement slurry, which has the same fluid properties as Class H, and has been pilot and field blend tested to have as good or better compressive strength development at our target densities.

#### Offline Cementing Request

Oxy requests a variance to cement the 9.625" and/or 7.625" intermediate casing strings offline in accordance to the approved variance, EC Tran 461365. Please see Offline Cementing Variance attachment for further details.



## Oxy Blanket Design - Casing Design "B"



### Bradenhead CBL Request

Oxy requests permission to adjust the CBL requirement after bradenhead cement jobs, on 7-5/8" intermediate casings, as per the agreement reached in the OXY/BLM meeting on September 5, 2019. Please see Bradenhead CBL Variance attachment for further details.

### 4. Pressure Control Equipment

BOP installed and tested before drilling which hole?	Size?	Min. Required WP	Type	✓	Tested to:	TVD Depth (ft) per Section:
12.25" Hole	13-5/8"	5M	Annular	✓	70% of working pressure	4832
		5M	Blind Ram	✓	250 psi / 5000 psi	
			Pipe Ram			
			Double Ram	✓		
			Other*			
9.875" Hole	13-5/8"	5M	Annular	✓	70% of working pressure	12102
		5M	Blind Ram	✓	250 psi / 5000 psi	
			Pipe Ram			
			Double Ram	✓		
			Other*			
6.75" Hole	13-5/8"	5M	Annular	✓	100% of working pressure	12775
		10M	Blind Ram	✓	250 psi / 10000 psi	
			Pipe Ram			
			Double Ram	✓		
			Other*			

\*Specify if additional ram is utilized

\*\*Curve could be in intermediate or production section

BOP/BOPE will be tested by an independent service company to 250 psi low and the high pressure indicated above per 43 CFR part 3170 Subpart 3172 requirements. The System may be upgraded to a higher pressure but still tested to the working pressure listed in the table above. If the system is upgraded all the components installed will be functional and tested.

Pipe rams will be operationally checked each 24 hour period. Blind rams will be operationally checked on each trip out of the hole. These checks will be noted on the daily tour sheets. Other accessories to the BOP equipment will include a Kelly cock and floor safety valve (inside BOP) and choke lines and choke manifold. See attached schematics.

### 5M Annular BOP Request

Per BLM's Memorandum No. NM-2017-008: *Decision and Rationale for a Variance Allowing the Use of a 5M Annular Preventer with a 10M BOP Stack*, Oxy requests to employ a 5M annular with a 10M BOPE stack in the pilot and lateral sections of the well and will ensure that two barriers to flow are



## Oxy Blanket Design - Casing Design "B"



Formation integrity test will be performed per 43 CFR part 3170 Subpart 3172.

On Exploratory wells or on that portion of any well approved for a 5M BOPE system or greater, a pressure integrity test of each casing shoe shall be performed. Will be tested in accordance with 43 CFR part 3170 Subpart 3172.

A variance is requested for the use of a flexible choke line from the BOP to Choke Manifold. Coflex hoses are in compliance with API 16C and meets inspection and testing requirements. See attached for specs and hydrostatic test chart.

Y Are anchors required by manufacturer?

A multibowl or a unionized multibowl wellhead system will be employed. The wellhead and connection to the BOPE will meet all API 6A requirements. The BOP will be tested per 43 CFR part 3170 Subpart 3172 after installation on the surface casing which will cover testing requirements for a maximum of 30 days. If any seal subject to test pressure is broken the system must be tested. We will test the flange connection of the wellhead with a test port that is directly in the flange. We are proposing that we will run the wellhead through the rotary prior to cementing surface casing as discussed with the BLM on October 8, 2015.

See attached Schematics.

### **BOP Break Testing Request**

Oxy requests permission to adjust the BOP break testing (intermediate and production) requirements as per the agreement reached in the OXY/BLM meeting on April 4th, 2025. Please see BOP Break Testing Variance attachment for further details.

### **Hammer Union Variance**

Oxy requests permission for hammer unions behind the choke to be routed to the gas buster. The hammer unions will not be subject to wellbore pressure in compliance with API STD 53.

Oxy will use Cameron ADAPT wellhead system that uses an OEC top flange connection. This connection has been fully vetted and verified by API to Spec 6A and carries an API monogram.



## Oxy Blanket Design - Casing Design "B"



### 5. Mud Program & Drilling Conditions

Section	Depth - MD		Depth - TVD		Type	Weight (ppg)	Viscosity	Water Loss
	From (ft)	To (ft)	From (ft)	To (ft)				
Surface	0	1200	0	1200	Water-Based Mud	8.6 - 8.8	40-60	N/C
Intermediate 1	1200	4832	1200	4832	Saturated Brine-Based or Oil-Based Mud	8.0 – 10.0	35-45	N/C
Intermediate 2	1200	13111*	1200	12775*	Saturated Brine-Based or Oil-Based Mud	8.0 - 10.0	35-45	N/C
Production	13111	23361	12775	12775	Water-Based or Oil-Based Mud	9.5 - 13.5	38-50	N/C

\*Curve could be in intermediate or production section\*

Sufficient mud materials to maintain mud properties and meet minimum lost circulation and weight increase requirements will be kept on location at all times. The following is a general list of products: Barite, Bentonite, Gypsum, Lime, Soda Ash, Caustic Soda, Nut Plug, Cedar Fiber, Cotton Seed Hulls, Drilling Paper, Salt Water Clay, CACL2. Oxy will use a closed mud system.

#### Drilling Blind Request

In the event total losses are encountered in the intermediate section, Oxy requests permission to drill blind due to depleted formations where risk of hydrocarbon kicks are unlikely.

- Oxy will first attempt to cure losses before proceeding with drilling blind
- Drilling blind will only be allowed in the Castille and formations below
- While drilling blind, will monitor backside by filling-up on connections and utilizing gas monitors
- Depths at which losses occurred and attempt to cure losses with relevant details (LCM sweep info, etc.) will be documented in the drillers log and Subsequent Reports to the BLM.
- If a well control event (hydrocarbon kick) occurs while drilling blind, the BLM will be notified after the well is secured and returned to static.

What will be used to monitor the loss or gain of fluid?	PVT/MD Totco/Visual Monitoring
---	--------------------------------

Pump high viscosity sweeps as needed for hole cleaning. The mud system will be monitored visually/manually as well as with an electronic PVT. The necessary mud products for additional weight and fluid loss control will be on location at all times. Appropriately weighted mud will be used to isolate potential gas, oil, and water zones until such time as casing can be cemented into place for zonal isolation.



# Oxy Blanket Design - Casing Design "B"



## 6. Wellbore Diagram

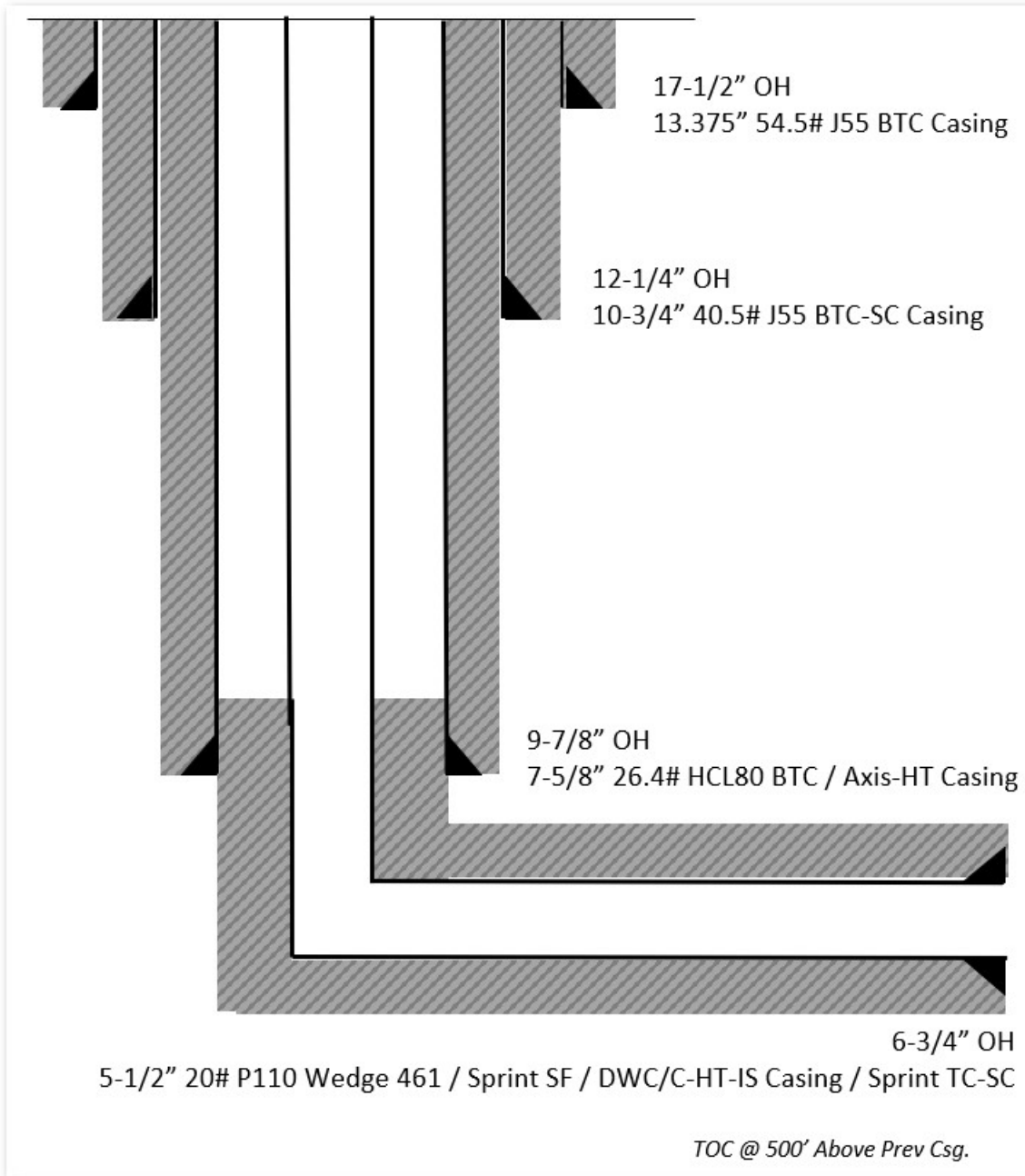



# Oxy Blanket Design - Casing Design "B"



## 7. Landmark StressCheck Screenshots – Triaxial Output

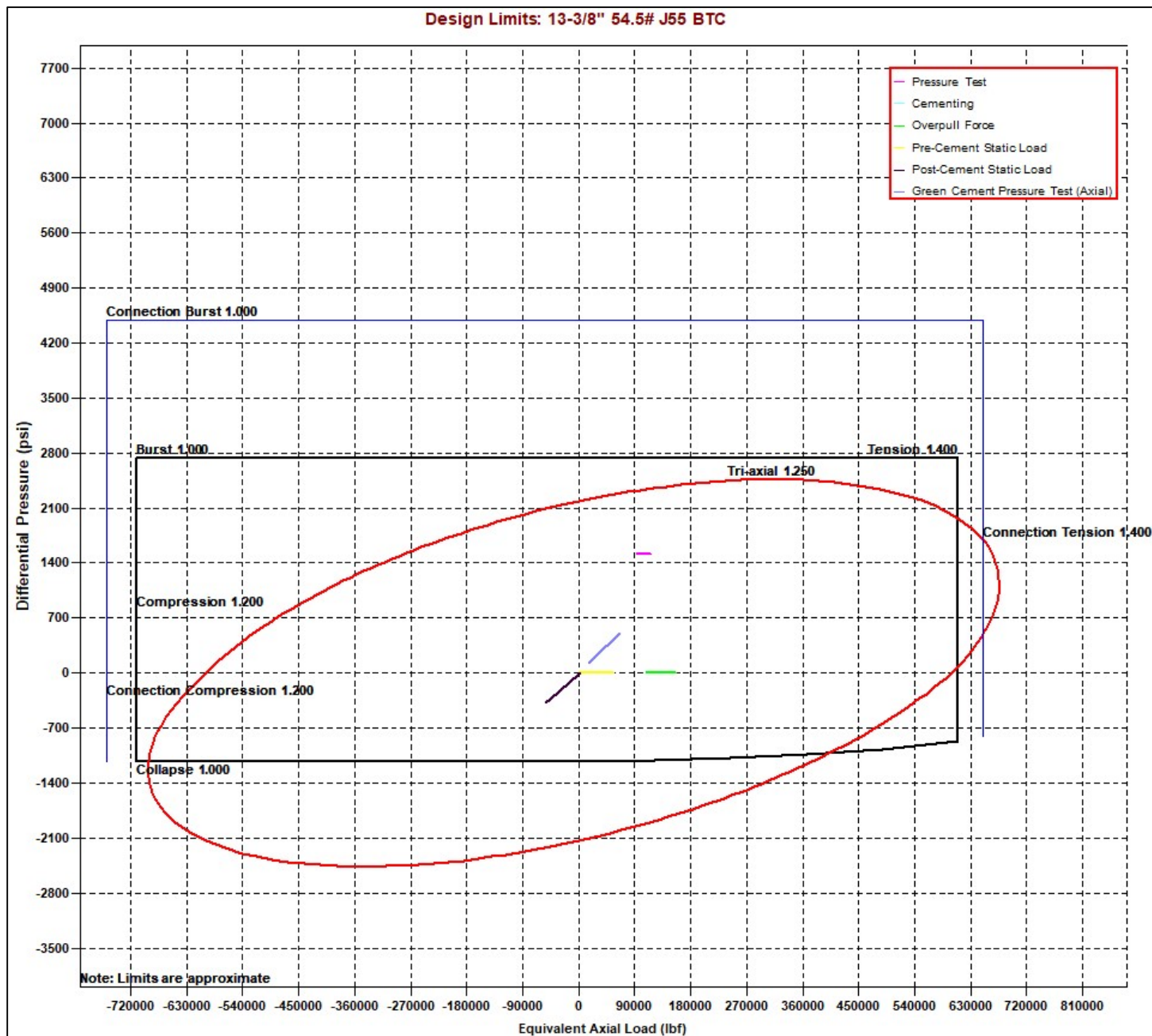



# Oxy Blanket Design - Casing Design "B"

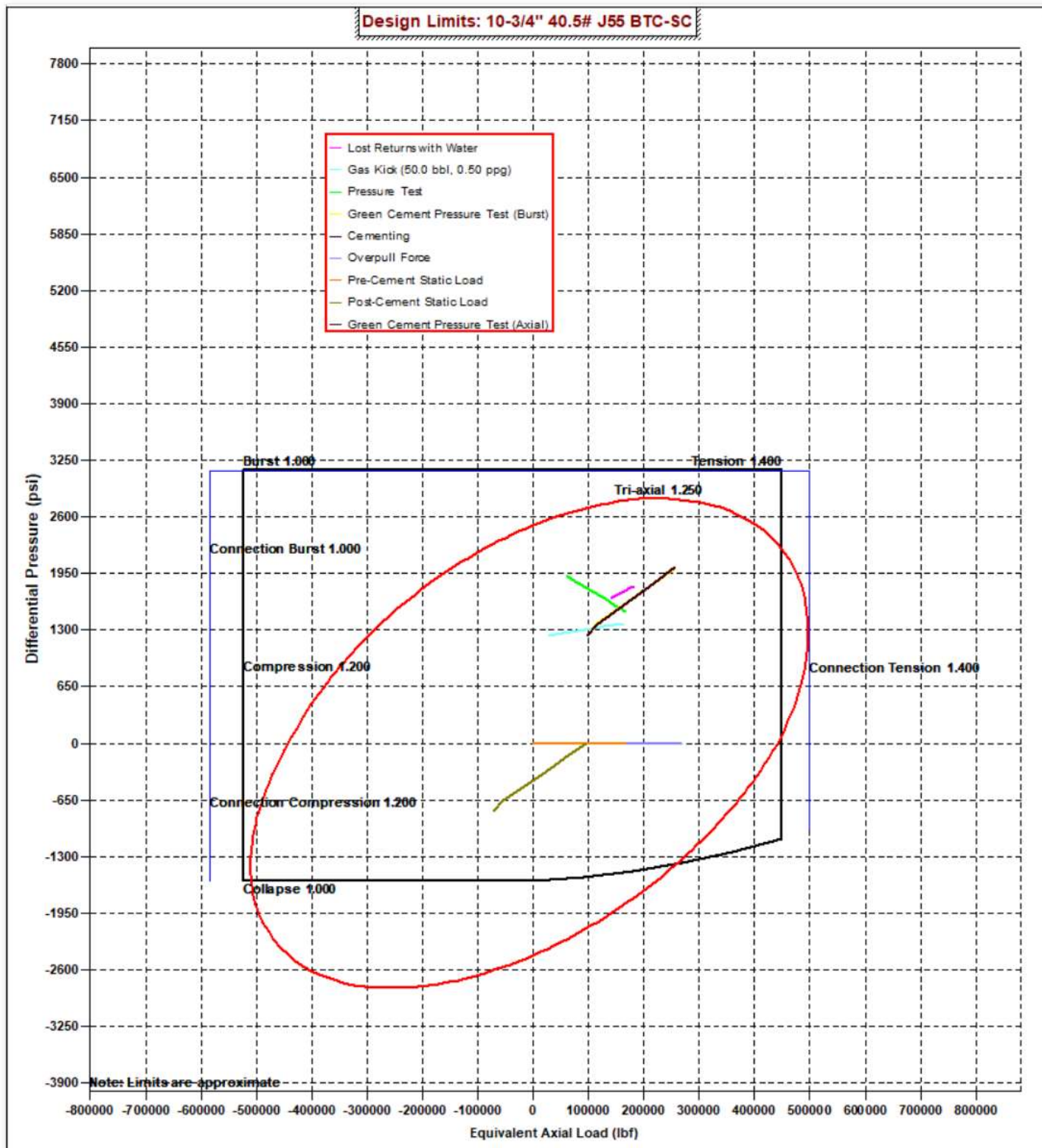



# Oxy Blanket Design - Casing Design "B"



Design Limits: 7-5/8" 26.4# HC-L80 BTC

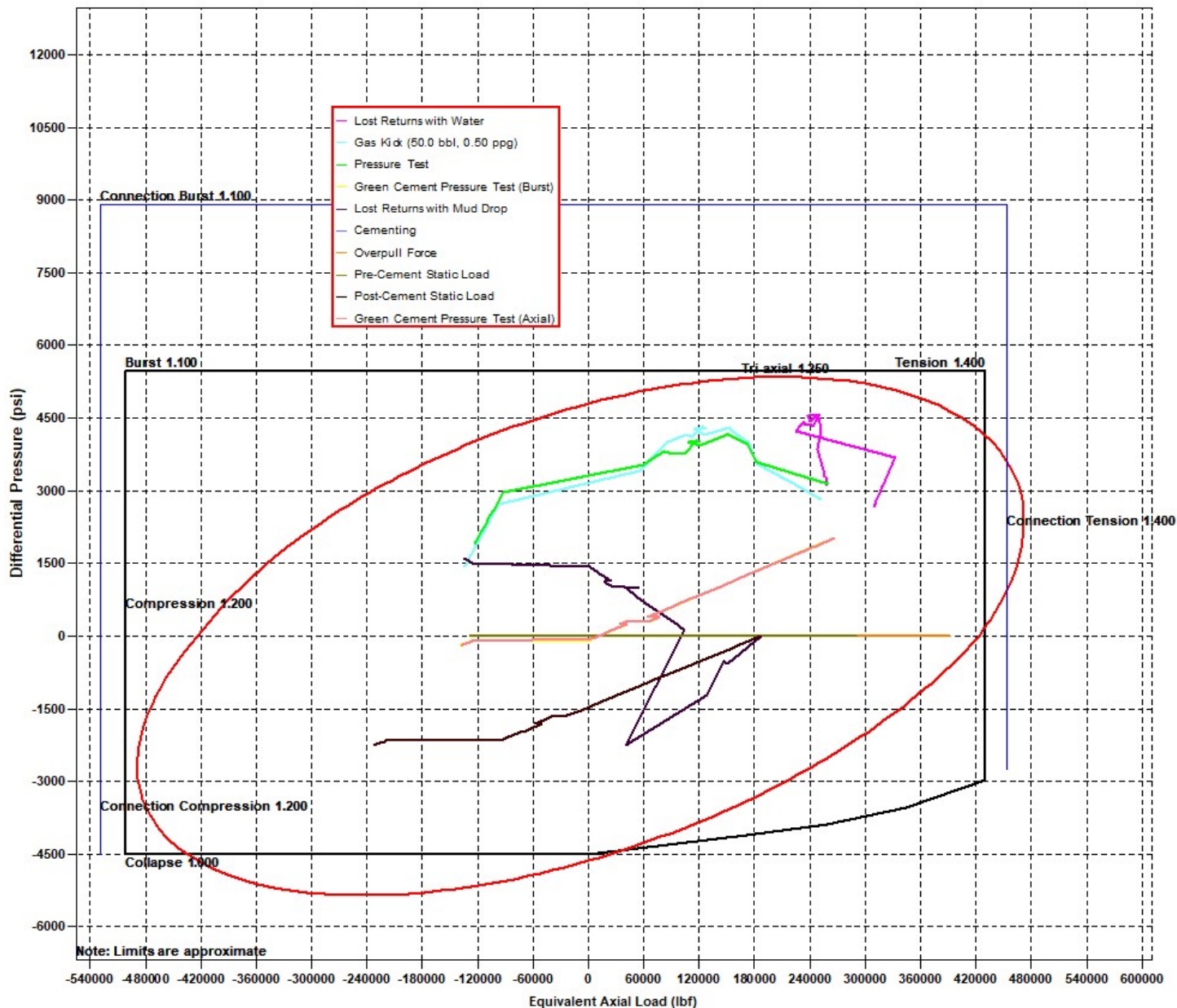



# Oxy Blanket Design - Casing Design "B"



Design Limits: 5-1/2" 20# P110 Sprint SF

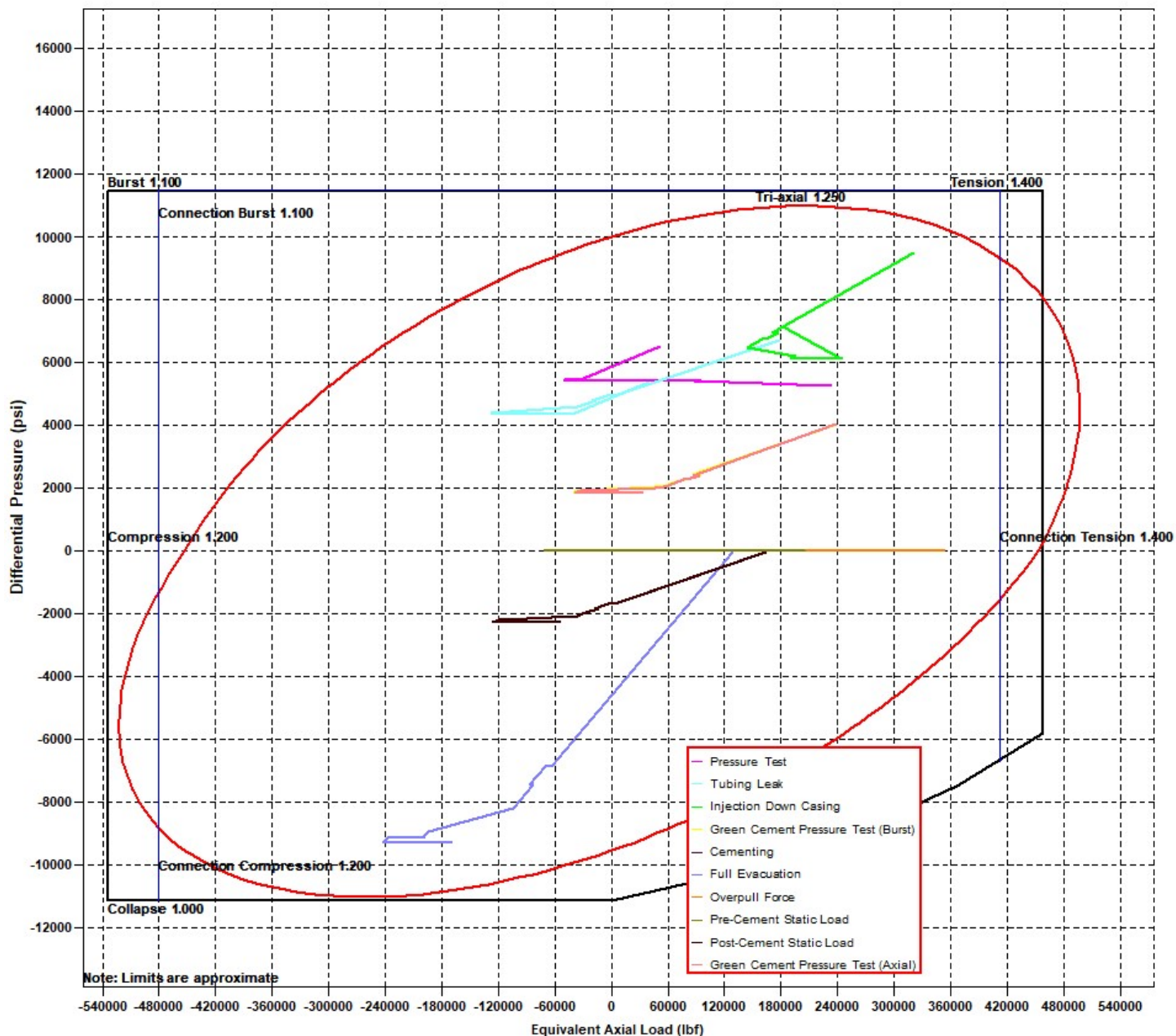

Note: Limits are approximate



## Oxy Blanket Design - Casing Design "B"



### 8. Landmark StressCheck Screenshots – Inputs for Intermediate 2 CSG Load Cases

#### Burst Load Cases

7 5/8" Intermediate Casing

Burst Loads Data	
<b>Drilling Load:</b>	<b>Lost Returns with Water</b>
Fracture at Shoe (MD= 13111.00 ft):	10591 psi
Mud/Water Interface, MD:	0.00 ft
Mud Weight	11.28 ppg
Assigned External Pressure:	Fluid Gradients (w/ Pore Pressure)
<b>Drilling Load:</b>	<b>Gas Kick Profile</b>
Influx Depth, MD:	23361.00 ft
Kick Volume:	50.0 bbl
Kick Intensity	0.50 ppg
Maximum Mud Weight:	13.50 ppg
Kick Gas Gravity:	0.55 (0.1159 psi/ft @ 182 °F & 9291 psi)
Fracture at Shoe (MD= 13111.00 ft):	10591 psi
Drill Pipe OD:	5.000 in
Collar OD:	5.500 in
Collar Length:	200.00 ft
Assigned External Pressure:	Fluid Gradients (w/ Pore Pressure)
<b>Drilling Load:</b>	<b>Pressure Test</b>
Test Pressure:	3120 psi
Mud Weight:	10.00 ppg
Assigned External Pressure:	Fluid Gradients (w/ Pore Pressure)
<b>Drilling Load:</b>	<b>Green Cement Pressure Test</b>
Test Pressure:	4000 psi
Mud Weight at Shoe:	10.00 ppg
TOC, MD:	25.00 ft
Lead Slurry Density:	13.30 ppg
Tail Slurry Density:	13.20 ppg
Tail Slurry Length:	5909.00 ft
Displacement Fluid Density:	10.00 ppg
Float Collar Depth, MD:	13111.00 ft
<b>External Pressure:</b>	<b>Fluid Gradients (w/ Pore Pressure)</b>
TOC, MD:	25.00 ft
Prior Shoe, MD:	4832.00 ft
Mud Weight Above TOC:	10.00 ppg
Fluid Gradient Below TOC:	8.33 ppg
Wellhead Pressure:	18 psi
Pore Pressure In Open Hole:	Yes



# Oxy Blanket Design - Casing Design "B"



## Collapse Load Cases

Collapse Loads Data	
<b>Drilling Load:</b>	<b>Cementing</b>
Mud Weight at Shoe:	10.00 ppg
TOC, MD:	25.00 ft
Lead Slurry Density:	13.30 ppg
Tail Slurry Density:	13.20 ppg
Tail Slurry Length:	5909.00 ft
Displacement Fluid Density:	10.00 ppg
Float Collar Depth, MD:	13111.00 ft
Assigned External Pressure:	Fluid Gradients (w/ Pore Pressure)
<b>Drilling Load:</b>	<b>Lost Returns with Mud Drop</b>
Lost Returns Depth, MD:	13111.10 ft
Pore Pressure at Lost Returns Depth:	7918 psi
Pore Pressure Gradient at Lost Returns Depth:	11.93 ppg
Mud Weight:	13.50 ppg
Mud Drop Level, MD:	1484.14 ft
Assigned External Pressure:	Fluid Gradients (w/ Pore Pressure)
<b>External Pressure:</b>	<b>Fluid Gradients (w/ Pore Pressure)</b>
TOC, MD:	25.00 ft
Prior Shoe, MD:	4832.00 ft
Fluid Gradient Above TOC:	10.00 ppg
Fluid Gradient Below TOC:	10.00 ppg
Wellhead Pressure:	18 psi
Pore Pressure In Open Hole Below TOC:	No

## Axial Load Cases

Axial Loads Data	
Overpull Force:	100000 lbf
Pre-Cement Static Load:	Yes
Pickup Force:	0 lbf
Post-Cement Static Load:	Yes
Green Cement Pressure Test:	2000 psi
Service Loads:	Yes



# Oxy Blanket Design - Casing Design "B"



## 9. Landmark StressCheck Screenshot – Int. Casing Triaxial Results Table (Pressure Test)

Depth (MD) (ft)	Axial Force (lb)		Equivalent Axial Load (lb)	Bending Stress at OD (psi)	Absolute Safety Factor				Temperature (°F)	Pressure (psi)		Add'l Pickup To Prevent Buck. (lb)	Buckled Length (ft)
	Apparent (w/Bending)	Actual (w/o Bending)			Triaxial	Burst	Collapse (V)	Axial		Internal	External		
29	12400	-149056	-24069	-99987	16622.5	1.88	2.25	N/A	(3.90)	179	9555	6970	
30	12500	-155877	-30890	-105328	16622.5	1.96	2.42	N/A	(3.73)	180	9603	7193	
31	12500	-155878	-30891	-105329	16622.5	1.96	2.42	N/A	(3.73)	180	9603	7193	
32	12550	-159065	-34078	-107825	16622.5	2.00	2.50	N/A	(3.66)	180	9625	7298	
33	12550	-159066	-34079	-107826	16622.5	2.00	2.50	N/A	(3.66)	180	9625	7298	
34	12600	-162071	-37084	-110180	16622.5	2.03	2.59	N/A	(3.59)	180	9646	7396	
35	12600	-162072	-37085	-110181	16622.5	2.03	2.59	N/A	(3.59)	180	9646	7396	
36	12650	-164872	-39885	-112376	16622.5	2.07	2.67	N/A	(3.53)	181	9665	7488	
37	12650	-164873	-39886	-112377	16622.5	2.07	2.67	N/A	(3.53)	181	9665	7488	
38	12700	-167448	-42461	-114394	16622.5	2.10	2.76	N/A	(3.47)	181	9683	7573	
39	12700	-167449	-42462	-114395	16622.5	2.10	2.76	N/A	(3.47)	181	9683	7573	
40	12750	-169778	-44791	-116221	16622.5	2.14	2.84	N/A	(3.43)	181	9699	7649	
41	12750	-169779	-44792	-116222	16622.5	2.14	2.84	N/A	(3.43)	181	9699	7649	
42	12800	-171844	-46858	-117841	16622.5	2.17	2.91	N/A	(3.38)	181	9714	7717	
43	12800	-171845	-46858	-117842	16622.5	2.17	2.91	N/A	(3.38)	181	9714	7717	
44	12850	-173632	-48645	-119243	16622.5	2.19	2.98	N/A	(3.35)	182	9726	7775	
45	12850	-173633	-48646	-119244	16622.5	2.19	2.98	N/A	(3.35)	182	9726	7775	
46	12900	-175127	-50141	-120416	16622.5	2.21	3.04	N/A	(3.32)	182	9736	7824	
47	12900	-175128	-50141	-120416	16622.5	2.21	3.04	N/A	(3.32)	182	9736	7824	
48	12950	-176319	-51332	-121350	16622.5	2.23	3.09	N/A	(3.30)	182	9745	7863	
49	13000	-177197	-52210	-122039	16622.5	2.24	3.13	N/A	(3.28)	182	9751	7892	
50	13050	-177755	-52769	-122477	16622.5	2.25	3.15	N/A	(3.27)	182	9755	7910	
51	13050	-177756	-52769	-122477	16622.5	2.25	3.15	N/A	(3.27)	182	9755	7910	
52	13111	-177998	-53011	-122667	16622.5	2.25	3.16	N/A	(3.27)	182	9756	7918	
53													
54													
55													
56													

Internal Pressure = Surface Pressure + Hydrostatic = 9756 psi  
 External Pressure = Fluid Gradient w/ Pore Pressure = 7918 psi  
 Burst SF = 3.16

NOTE: Specific load case inputs for the pressure test can be seen in **Section 8** above. The test pressure does not exceed 70% of the minimum internal yield.



# Oxy Blanket Design - Casing Design "B"



## 10. Intermediate Non-API Casing Spec Sheet



### API BTC -Special Clearance

Coupling	Pipe Body
Grade: J55 (Casing)	Grade: J55 (Casing)
Body: Bright Green	1st Band: Bright Green
1st Band: White	2nd Band: -
2nd Band: -	3rd Band: -
3rd Band: -	4th Band: -

Printed on: 06-19-2025

Outside Diameter	10.750 in.	Wall Thickness	0.350 in.	Grade	J55 (Casing)
Min. Wall Thickness	87.50 %	Pipe Body Drift	API Standard	Type	Casing
Connection OD Option	Special Clearance				

#### Pipe Body Data

Geometry		Performance	
Nominal OD	10.750 in.	Drift	9.894 in.
Wall Thickness	0.350 in.	Plain End Weight	38.91 lb/ft
Nominal Weight	40.500 lb/ft	OD Tolerance	API
Nominal ID	10.050 in.		

SMYS	55,000 psi
Min UTS	75,000 psi
Body Yield Strength	629 x1000 lb
Min. Internal Yield Pressure	3130 psi
Collapse Pressure	1580 psi
Max. Allowed Bending	23 °/100 ft

#### Connection Data

Geometry		Performance	
Thread per In	5	Joint Strength	700 x1000 lb
Connection OD	11.250 in.	Coupling Face Load	329 x1000 lb
Hand Tight Stand Off	1 in.	Internal Pressure Capacity	3130 psi

#### Notes

For products according to API Standards 5CT & 5B; Performance calculated considering API Technical Report 5C3 (Sections 9 & 10) equations.  
 For geometrical and steel grades combinations not considered in the API Standards 5CT and/or 5B; Performance calculations indirectly derived from API Technical Report 5C3 (Sections 9 & 10) equations.  
 Couplings OD are shown according to current API 5CT 10th Edition.

Tenaris has issued this document for general information only and the information in this document, including, without limitation, any pictures, drawings or designs ("information") is not intended to constitute professional or any other type of advice or recommendation and is provided on an "as is" basis. No warranty is given. Tenaris has not independently verified any information –if any- provided by the user in connection with, or for the purpose of, the information contained hereunder. The use of the information is at user's own risk and Tenaris does not assume any responsibility or liability of any kind for any loss, damage or injury resulting from, or in connection with any information contained hereunder or any use thereof. The information in this document is subject to change or modification without notice. Tenaris's products and services are subject to Tenaris's standard terms and conditions or otherwise to the terms resulting from the respective contracts of sale or services, as the case may be, between petitioner and Tenaris. For more complete information please contact a Tenaris's representative or visit our website at [www.tenaris.com](http://www.tenaris.com). ©Tenaris 2025. All rights reserved.



## Oxy Blanket Design - Casing Design "B"



### Technical Data Sheet

7 5/8" 26.40 lbs/ft. L80HC - Axis HT

#### Mechanical Properties

Minimum Yield Strength	psi.	80,000
Maximum Yield Strength	psi.	95,000
Minimum Tensile Strength	psi.	95,000

#### Dimensions

		Pipe	AXIS HT
Outside Diameter	in.	7.625	8.500
Wall Thickness	in.	0.328	-
Inside Diameter	in.	6.969	-
Standard Drift	in.	6.844	6.844
Alternate Drift	in.	-	-
Plain End Weight	lbs/ft.	-	-
Nominal Linear Weight	lbs/ft.	26.40	-

#### Performance

		Pipe	AXIS HT
Minimum Collapse Pressure	psi.	4,320	-
Minimum Internal Yield Pressure	psi.	6,020	6,020
Minimum Pipe Body Yield Strength	lbs.	602 x 1,000	-
Joint Strength	lbs.	-	635 x 1,000

#### Make-Up Torques

		Pipe	AXIS HT
Optimum Make-Up Torque	ft/lbs.	-	8,000
Maximum Operational Torque	ft/lbs.	-	25,000

Disclaimer: The content of this Technical Data Sheet is for general information only and does not guarantee performance and/or accuracy, which can only be determined by a professional expert with the specific installation and operation parameters. Information printed or downloaded may not be current and no longer in control by Axis Pipe and Tube. Anyone using the information herein does so at his or her own risk. To verify that you have the latest technical information, please contact Axis Pipe and Tube Technical Sales +1 (979) 599-7600. [www.axispipeandtube.com](http://www.axispipeandtube.com)

## 11. Production Non-API Casing Spec Sheets



# Oxy Blanket Design - Casing Design "B"



Printed on: 11/09/2021

Tenaris

## TenarisHydril Wedge 461<sup>®</sup> MS



Coupling	Pipe Body
Grade: P110-ICV	Grade: P110-ICV
Body: White	1st Band: White
1st Band: Pale Green	2nd Band: Pale Green
2nd Band: -	3rd Band: Pale Green
3rd Band: -	4th Band: -
	5th Band: -
	6th Band: -

Outside Diameter	5.500 in.	Wall Thickness	0.361 in.	Grade	P110-ICV
Min. Wall Thickness	87.50 %	Pipe Body Drift	API Standard	Type	Casing
Connection OD Option	MS				

### Pipe Body Data

Geometry		Performance	
Nominal OD	5.500 in.	Wall Thickness	0.361 in.
Nominal Weight	20 lb/ft	Plain End Weight	19.83 lb/ft
Drift	4.653 in.	OD Tolerance	API
Nominal ID	4.778 in.		
		Body Yield Strength	729 x1000 lb
		Min. Internal Yield Pressure	14,360 psi
		SMYS	125,000 psi
		Collapse Pressure	12,300 psi

### Connection Data

Geometry		Performance		Make-Up Torques	
Connection OD	6.050 in.	Tension Efficiency	100 %	Minimum	17,000 ft-lb
Coupling Length	7.714 in.	Joint Yield Strength	729 x1000 lb	Optimum	18,000 ft-lb
Connection ID	4.778 in.	Internal Pressure Capacity	14,360 psi	Maximum	21,600 ft-lb
Make-up Loss	3.775 in.	Compression Efficiency	100 %		
Threads per inch	3.40	Compression Strength	729 x1000 lb	Operation Limit Torques	
Connection OD Option	Ms	Max. Allowable Bending	104 °/100 ft	Operating Torque	43,000 ft-lb
		External Pressure Capacity	12,300 psi	Yield Torque	51,000 ft-lb
		Coupling Face Load	273,000 lb	Buck-On	
				Minimum	21,600 ft-lb
				Maximum	23,100 ft-lb

### Notes

This connection is fully interchangeable with:  
 Wedge 441@ - 5.5 in. - 0.304 / 0.361 in.  
 Wedge 461@ - 5.5 in. - 0.304 / 0.415 / 0.476 in.  
 Connections with Dopeless® Technology are fully compatible with the same connection in its Standard version  
 In October 2019, TenarisHydril Wedge XP® 2.0 was renamed TenarisHydril Wedge 461™. Product dimensions and properties remain identical and both connections are fully interchangeable

For the latest performance data, always visit our website: [www.tenaris.com](http://www.tenaris.com)

Tenaris has issued this document for general information only, and the information in this document, including, without limitation, any pictures, drawings or designs ("Information") is not intended to constitute professional or any other type of advice or recommendation and is provided on an "as is" basis. No warranty is given. Tenaris has not independently verified any information –if any- provided by the user in connection with, or for the purpose of, the Information contained hereunder. The use of the Information is at user's own risk and Tenaris does not assume any responsibility or liability of any kind for any loss, damage or injury resulting from, or in connection with any Information contained hereunder or any use thereof. The Information in this document is subject to change or modification without notice. Tenaris's products and services are subject to Tenaris's standard terms and conditions or otherwise to the terms resulting from the respective contracts of sale or services, as the case may be, between petitioner and Tenaris. For more complete information please contact a Tenaris's representative or visit our website at [www.tenaris.com](http://www.tenaris.com). ©Tenaris 2021. All rights reserved.



# Oxy Blanket Design - Casing Design "B"



Generated on May 21, 2024



## CONNECTION DATA SHEET

OD: 5.500 in.      Grade: P110  
 Weight: 20.00 lb/ft      Drift: 4.653 in. (API)  
 Wall Th.: 0.361 in.

### VAM® SPRINT-SF

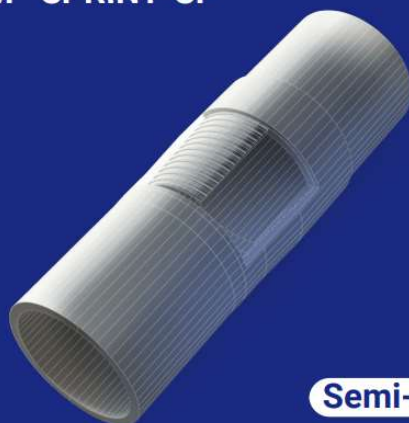

**Semi-Flush**

#### Field Torque Values

##### Make-up Torque (ft-lb)

- 20,000 MIN
- 22,500 OPTI
- 25,000 MAX

##### Torque with Sealability (ft-lb)

- 36,000 MTS

##### Locked Flank Torque (ft-lb)

- 4,500 MIN
- 15,750 MAX

(2) MTS: Maximum Torque with Sealability.

#### PIPE BODY PROPERTIES

Nominal OD	5.500	in.
Nominal ID	4.778	in.
Nominal Wall Thickness	0.361	in.
Minimum Wall Thickness	87.5	%
Nominal Weight (API)	20.00	lb/ft
Plain End Weight	19.83	lb/ft
Drift	4.653	in.
Grade Type	API 5CT	
Minimum Yield Strength	110	ksi
Maximum Yield Strength	140	ksi
Minimum Ultimate Tensile Strength	125	ksi
Pipe Body Yield Strength	641	klb
Internal Yield Pressure	12,640	psi
Collapse Pressure	11,100	psi

#### CONNECTION PROPERTIES

Connection Type	Semi-Premium Integral	Semi-Flu
Nominal Connection OD	5.783	in.
Nominal Connection ID	4.718	in.
Make-up Loss	5.965	in.
Tension Efficiency	90	% Pipe Body
Compression Efficiency	90	% Pipe Body
Internal Pressure Efficiency	100	% Pipe Body
External Pressure Efficiency	100	% Pipe Body

#### JOINT PERFORMANCES

Tension Strength	577	klb
Compression Strength	577	klb
Internal Pressure Resistance	12,640	psi
External Pressure Resistance	11,100	psi
Maximum Bending, Structural	78	°/100 ft
Maximum Bending, with Sealability(1)	30	°/100 ft

(1) Sealability rating demonstrated as per API RP-5C5 / ISO 13679



**BOOST YOUR EFFICIENCY, REDUCE COSTS  
 AND ENSURE 100% WELL INTEGRITY WITH  
 VAM® FIELD SERVICE**

Scan the QR code  
to contact us



The information available on this Site ("Information") is offered for general information. It is supposed to be correct at the time of publishing on the Site but is not intended to constitute professional advice and is provided 'as is'. Vallourec does not guarantee the completeness and accuracy of this information. Under no circumstances will Vallourec be liable for damage, liability of any kind, or any loss or injury that may result from the credibility given to this information or its use. The information may be amended, corrected, at any time by Vallourec without warning. Vallourec's products and services are subject to Vallourec's The Information may be amended, corrected, and/or supplemented at any time by Vallourec without warning, standard terms and conditions or otherwise to the terms resulting from the respective contracts of sale or services.



# Oxy Blanket Design - Casing Design "B"



**DWC/C-HT-IS**

## Connection Data Sheet

OD (in.)	WEIGHT (lbs./ft.)	WALL (in.)	GRADE	API DRIFT (in.)	RBW%	CONNECTION
5.500	Nominal: 20.00 Plain End: 19.83	0.361	‡VST P110MY	4.653	87.5	DWC/C-HT-IS

PIPE PROPERTIES		
Nominal OD	5.500	in.
Nominal ID	4.778	in.
Nominal Area	5.828	sq.in.
Grade Type	API 5CT	
Min. Yield Strength	125	ksi
Max. Yield Strength	140	ksi
Min. Tensile Strength	135	ksi
Yield Strength	729	klb
Ultimate Strength	787	klb
Min. Internal Yield Pressure	14,360	psi
Collapse Pressure	12,090	psi

CONNECTION PROPERTIES		
Connection Type	Semi-Premium T&C	
Connection OD (nom)	6.050	in.
Connection ID (nom)	4.778	in.
Make-Up Loss	4.125	in.
Coupling Length	9.250	in.
Critical Cross Section	5.828	sq.in.
Tension Efficiency	89.1%	of pipe
Compression Efficiency	88.0%	of pipe
Internal Pressure Efficiency	86.1%	of pipe
External Pressure Efficiency	100.0%	of pipe

CONNECTION PERFORMANCES		
Yield Strength	649	klb
Parting Load	729	klb
Compression Rating	641	klb
Min. Internal Yield Pressure	12,360	psi
External Pressure Resistance	12,090	psi
Maximum Uniaxial Bend Rating	91.7	°/100 ft
Reference String Length w 1.4 Design Factor	22,890	ft.

FIELD TORQUE VALUES		
Min. Make-up torque	16,600	ft.lb
Opti. Make-up torque	17,950	ft.lb
Max. Make-up torque	19,300	ft.lb
Min. Shoulder Torque	1,660	ft.lb
Max. Shoulder Torque	13,280	ft.lb
Max. Delta Turn	0.200	Turns
‡Maximum Operational Torque	23,800	ft.lb
‡Maximum Torsional Value (MTV)	26,180	ft.lb

‡ Maximum Operational Torque and Maximum Torsional Value only valid with Vallourec P110MY Material.  
 ‡ P110MY - Coupling Min Yield Strength is 110ksi and Coupling Max Yield is 125ksi.

"VST = Vallourec Star as the mill source for the pipe, "P110EC" is the grade name"

Need Help? Contact: [tech.support@vam-usa.com](mailto:tech.support@vam-usa.com)

For detailed information on performance properties, refer to DWC Connection Data Notes on following page(s).

Connection specifications within the control of VAM USA were correct as of the date printed. Specifications are subject to change without notice. Certain connection specifications are dependent on the mechanical properties of the pipe. Mechanical properties of mill proprietary pipe grades were obtained from mill publications and are subject to change. Properties of mill proprietary grades should be confirmed with the mill. Users are advised to obtain current connection specifications and verify pipe mechanical properties for each application.

All information is provided by VAM USA or its affiliates at user's sole risk, without liability for loss, damage or injury resulting from the use thereof; and on an "AS IS" basis without warranty or representation of any kind, whether express or implied, including without limitation any warranty of merchantability, fitness for purpose or completeness. This document and its contents are subject to change without notice. In no event shall VAM USA or its affiliates be responsible for any indirect, special, incidental, punitive, exemplary or consequential loss or damage (including without limitation, loss of use, loss of bargain, loss of revenue, profit or anticipated profit) however caused or arising, and whether such losses or damages were foreseeable or VAM USA or its affiliates was advised of the possibility of such damages.

03/04/2024 08:36:50 PM





## Oxy Blanket Design - Casing Design "B"



VAM USA  
 2107 CityWest Boulevard Suite 1300  
 Houston, TX 77042  
 Phone: 713-479-3200  
 Fax: 713-479-3234  
 VAM<sup>®</sup> USA Sales E-mail: [VAMUSAsales@vam-usa.com](mailto:VAMUSAsales@vam-usa.com)  
 Tech Support Email: [tech.support@vam-usa.com](mailto:tech.support@vam-usa.com)

### DWC Connection Data Sheet Notes:

1. DWC connections are available with a seal ring (SR) option.
2. All standard DWC/C connections are interchangeable for a given pipe OD. DWC connections are interchangeable with DWC/C-SR connections of the same OD and wall.
3. Connection performance properties are based on nominal pipe body and connection dimensions.
4. DWC connection internal and external pressure resistance is calculated using the API rating for buttress connections. API Internal pressure resistance is calculated from formulas 31, 32, and 35 in the API Bulletin 5C3.
5. DWC joint strength is the minimum pipe body yield strength multiplied by the connection critical area.
6. API joint strength is for reference only. It is calculated from formulas 42 and 43 in the API Bulletin 5C3.
7. Bending efficiency is equal to the compression efficiency.
8. The torque values listed are recommended. The actual torque required may be affected by field conditions such as temperature, thread compound, speed of make-up, weather conditions, etc.
9. Connection yield torque is not to be exceeded.
10. Reference string length is calculated by dividing the joint strength by both the nominal weight in air and a design factor (DF) of 1.4. These values are offered for reference only and do not include load factors such as bending, buoyancy, temperature, load dynamics, etc.
11. DWC connections will accommodate API standard drift diameters.
12. DWC/C family of connections are compatible with API Buttress BTC connections. Please contact [tech.support@vam-usa.com](mailto:tech.support@vam-usa.com) for details on connection ratings and make-up.

Connection specifications within the control of VAM USA were correct as of the date printed. Specifications are subject to change without notice. Certain connection specifications are dependent on the mechanical properties of the pipe. Mechanical properties of mill proprietary pipe grades were obtained from mill publications and are subject to change. Properties of mill proprietary grades should be confirmed with the mill. Users are advised to obtain current connection specifications and verify pipe mechanical properties for each application.

All information is provided by VAM USA or its affiliates at user's sole risk, without liability for loss, damage or injury resulting from the use thereof; and on an "AS IS" basis without warranty or representation of any kind, whether express or implied, including without limitation any warranty of merchantability, fitness for purpose or completeness. This document and its contents are subject to change without notice. In no event shall VAM USA or its affiliates be responsible for any indirect, special, incidental, punitive, exemplary or consequential loss or damage (including without limitation, loss of use, loss of bargain, loss of revenue, profit or anticipated profit) however caused or arising, and whether such losses or damages were foreseeable or VAM USA or its affiliates was advised of the possibility of such damages.

03/04/2024 08:36:50 PM





# Oxy Blanket Design - Casing Design "B"



Generated on May 14, 2025



## CONNECTION DATA SHEET

OD: 5.500 in. Grade: P110 EC  
 Weight: 20.00 lb/ft Drift: 4.653 in. (API)  
 Wall Th.: 0.361 in.

### VAM® SPRINT-TC SC

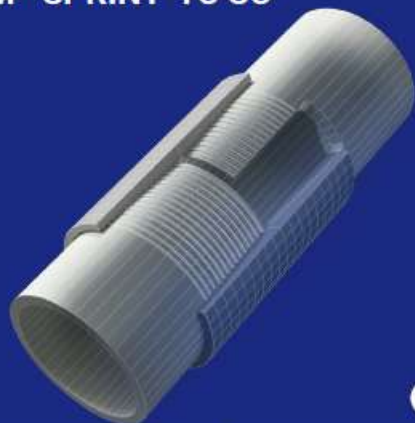

T&C

### Field Torque Values

#### Make-up Torque (ft-lb)

- 23,000 MIN
- 24,000 OPTI
- 25,000 MAX

#### Torque with Sealability (ft-lb)

- 39,200 MTS

#### Locked Flank Torque (ft-lb)

- 1,200 MIN
- 16,800 MAX

(1) MTS: Maximum Torque with Sealability.  
 (2) Note: Thread compound must be applied as a thin even layer

### PIPE BODY PROPERTIES

Nominal OD	5.500	in.
Nominal ID	4.778	in.
Nominal Wall Thickness	0.361	in.
Minimum Wall Thickness	87.5	%
Nominal Weight (API)	20.00	lb/ft
Plain End Weight	19.83	lb/ft
Drift	4.653	in.
Grade Type	High Yield	
Minimum Yield Strength	125	ksi
Maximum Yield Strength	140	ksi
Minimum Ultimate Tensile Strength	135	ksi
Pipe Body Yield Strength	729	kib
Internal Yield Pressure	14,360	psi
Collapse Pressure	12,090	psi

### CONNECTION PROPERTIES

Connection Type	Semi-Premium Threaded & Coupl	
Nominal Connection OD	5.900	in.
Nominal Connection ID	4.830	in.
Make-up Loss	3.973	in.
Coupling Length	8.296	in.
Tension Efficiency	100	% Pipe Body
Compression Efficiency	100	% Pipe Body
Internal Pressure Efficiency	100	% Pipe Body
External Pressure Efficiency	100	% Pipe Body

### JOINT PERFORMANCES

Tension Strength	729	kib
Compression Strength	729	kib
Internal Pressure Resistance	14,360	psi
External Pressure Resistance	12,090	psi
Maximum Bending, Structural	104	°/100 ft
Maximum Bending, with Sealability	30	°/100 ft
Maximum Load on Coupling Face	227	kib

(4) Sealability rating demonstrated as per API RP 5C5 / ISO 13679



**BOOST YOUR EFFICIENCY, REDUCE COSTS AND ENSURE 100% WELL INTEGRITY WITH VAM® FIELD SERVICE**

Scan the QR code to contact us



The information available on this Site ("Information") is offered for general information. It is supposed to be correct at the time of publishing on the Site but is not intended to constitute professional advice and is provided "as is". Vallourec does not guarantee the completeness and accuracy of this information. Under no circumstances will Vallourec be liable for damage, liability of any kind, or any loss or injury that may result from the credibility given to this information or its use. The information may be amended, corrected, at any time by Vallourec without warning. Vallourec's products and services are subject to Vallourec's standard terms and conditions or otherwise to the terms resulting from the respective contracts of sale or services. The information may be amended, corrected, and/or supplemented at any time by Vallourec without warning.



# Oxy Blanket Design - Casing Design "A"



## 1. Casing Program

The designs and associated details listed in this document are the "worst case scenario" boundaries for design safety factors.

Location and lithology have NOT been accounted for in these designs; however, the designs are NOT valid for wells within KPLA Boundaries or Capitan Reef areas. The specific well details will be based on the APD/Sundry package and the information listed in the COA.

The mud program listed below will remain the same between each design variation.

Hole will be full during casing run for well control and tensile SF.

Casing will be kept at least half full during run for these designs to meet BLM collapse SF requirement.

### Design Variation "A1"

Section	Hole Size (in)	MD		TVD		Csg. OD (in)	Csg Wt. (ppf)	Grade	Conn.
		From (ft)	To (ft)	From (ft)	To (ft)				
Surface	14.75	0	1200	0	1200	10.75	40.5	J-55	BTC
Intermediate	9.875	0	13111*	0	12775*	7.625	26.4	L-80 HC	BTC Axis HT GBCD
Production	6.75	0	23361	0	12775	5.5	20	P-110	Wedge 461 Sprint SF DWC/C-HT-IS Sprint-TC SC

\*Curve could be in intermediate or production section

### Design Variation "A2" - Option to Pivot to Design "B" for Contingency 4S

Section	Hole Size (in)	MD		TVD		Csg. OD (in)	Csg Wt. (ppf)	Grade	Conn.
		From (ft)	To (ft)	From (ft)	To (ft)				
Surface	17.5	0	1200	0	1200	13.375	54.5	J-55	BTC
Intermediate	12.25+	0	13111*	0	12775*	7.625	26.4	L-80 HC	BTC Axis HT GBCD
Production	6.75	0	23361	0	12775	5.5	20	P-110	Wedge 461 Sprint SF DWC/C-HT-IS Sprint-TC SC

\*Curve could be in intermediate or production section

†If 4S Contingency is not required, Oxy requests permission to transition from 12.25" to 9.875" Intermediate at some point during the hole section. Cement volumes will be updated on C103 submission.

All casing strings will be tested in accordance with 43 CFR part 3170 Subpart 3172



## Oxy Blanket Design - Casing Design "A"



<i>All Casing SF Values will meet or exceed those below</i>			
<b>SF Collapse</b>	<b>SF Burst</b>	<b>Body SF Tension</b>	<b>Joint SF Tension</b>
1.00	1.100	1.4	1.4

### §Annular Clearance Variance Request

As per the agreement reached in the Oxy/BLM face-to-face meeting on Feb 22, 2018, Oxy requests permission to allow deviation from the 0.422" annular clearance requirement. Please see Annular Clearance Variance attachment for further details.

§Annular Clearance Variance Request may not apply to all connections used or presented.

## 2. Trajectory / Boundary Conditions

Section	MD		TVD		Max. Angle	Max. Planned DLS
	Deepest KOP (ft)	End Build (ft)	Deepest KOP (ft)	End Build (ft)		
Surface	0	1200	0	1200	5°	1°/100 ft
Intermediate	5000 <small>(inside Cherry Canyon)</small>	6500	4980	6390	20°	2°/100 ft
	12211	13111	12202	12775	92° ‡	12°/100 ft ‡
Production	12211 <small>(~100' MD past ICP)</small>	13111	12202	12775	92° ‡	12°/100 ft ‡

‡ Applies only when intermediate casing depth is deepened to landing point to match TVD of production in some areas where required to accommodate higher MWs in depleted areas.

Oxy has reviewed casing burst, collapse, and axial loadcases in Landmark StressCheck with the boundary conditions in the table above which satisfies Oxy and BLM minimum design criteria. Triaxial plots for each casing string is shown in Section 7 and intermediate load case inputs are shown in Section 8.



## Oxy Blanket Design - Casing Design "A"



### 3. Cementing Program

NOTE: Blanket design is for technical review only. The cement volumes will be adjusted to ensure cement tops meet BLM requirements.

#### Design Variation "A1"

Section	Stage	Slurry:	Sacks	Yield (ft <sup>3</sup> /ft)	Density (lb/gal)	Excess:	TOC	Placement	Description
Surface	1	Surface - Tail	819	1.33	14.8	100%	-	Circulate	Class C+Accel.
Int.	1	Intermediate 1S - Tail	658	1.68	13.2	5%	7,206	Circulate	Class C+Ret., Disper.
Int.	2	Intermediate 2S - Tail BH	1111	1.71	13.3	25%	-	Bradenhead	Class C+Accel.
Prod.	1	Production - Tail	665	1.84	13.3	25%	11,611	Circulate	Class C+Ret.
Prod.	2*	Production - Tail BH*	TBD	1.84	13.3	50%	500' inside prev csg	Circulate	Class C+Ret.

\*Only applies in scenario where planned single stage job TOC is not 500' above previous shoe as designed/programmed requiring bradenhead 2nd stage to meet requirements

#### Design Variation "A2"

Section	Stage	Slurry:	Sacks	Yield (ft <sup>3</sup> /ft)	Density (lb/gal)	Excess:	TOC	Placement	Description
Surface	1	Surface - Tail	1023	1.33	14.8	100%	-	Circulate	Class C+Accel.
Int.	1	Intermediate 1S - Tail	658	1.68	13.2	5%	7,206	Circulate	Class C+Ret., Disper.
Int.	2	Intermediate 2S - Tail BH	1293	1.71	13.3	25%	-	Bradenhead	Class C+Accel.
Prod.	1	Production - Tail	665	1.84	13.3	25%	11,611	Circulate	Class C+Ret.
Prod.	2*	Production - Tail BH*	TBD	1.84	13.3	50%	500' inside prev csg	Circulate	Class C+Ret.

\*Only applies in scenario where planned single stage job TOC is not 500' above previous shoe as designed/programmed requiring bradenhead 2nd stage to meet requirements

As Reviewed and Approved by BLM on Feb 8, 2024: Oxy uses a Class C / Pozzolan mix on its production cement slurry, which has the same fluid properties as Class H, and has been pilot and field blend tested to have as good or better compressive strength development at our target densities.

#### Offline Cementing Request

Oxy requests a variance to cement the 9.625" and/or 7.625" intermediate casing strings offline in accordance to the approved variance, EC Tran 461365. Please see Offline Cementing Variance attachment for further details.

#### Bradenhead CBL Request

Oxy requests permission to adjust the CBL requirement after bradenhead cement jobs, on 7-5/8" intermediate casings, as per the agreement reached in the OXY/BLM meeting on September 5, 2019. Please see Bradenhead CBL Variance attachment for further details.



## Oxy Blanket Design - Casing Design "A"



### 4. Pressure Control Equipment

BOP installed and tested before drilling which hole?	Size?	Min. Required WP	Type	✓	Tested to:	Deepest TVD Depth (ft) per Section:
9.875" Hole	13-5/8"	5M	Annular	✓	70% of working pressure	12775**
		5M	Blind Ram	✓	250 psi / 5000 psi	
			Pipe Ram			
			Double Ram	✓		
			Other*			
6.75" Hole	13-5/8"	5M	Annular	✓	100% of working pressure	12775
		10M	Blind Ram	✓	250 psi / 10000 psi	
			Pipe Ram			
			Double Ram	✓		
			Other*			

\*Specify if additional ram is utilized

\*\*Curve could be in intermediate or production section

BOP/BOPE will be tested by an independent service company to 250 psi low and the high pressure indicated above per 43 CFR part 3170 Subpart 3172 requirements. The System may be upgraded to a higher pressure but still tested to the working pressure listed in the table above. If the system is upgraded all the components installed will be functional and tested.

Pipe rams will be operationally checked each 24 hour period. Blind rams will be operationally checked on each trip out of the hole. These checks will be noted on the daily tour sheets. Other accessories to the BOP equipment will include a Kelly cock and floor safety valve (inside BOP) and choke lines and choke manifold. See attached schematics.

#### 5M Annular BOP Request

Per BLM's Memorandum No. NM-2017-008: *Decision and Rationale for a Variance Allowing the Use of a 5M Annular Preventer with a 10M BOP Stack*, Oxy requests to employ a 5M annular with a 10M BOPE stack in the pilot and lateral sections of the well and will ensure that two barriers to flow are



## Oxy Blanket Design - Casing Design "A"



Formation integrity test will be performed per 43 CFR part 3170 Subpart 3172.

On Exploratory wells or on that portion of any well approved for a 5M BOPE system or greater, a pressure integrity test of each casing shoe shall be performed. Will be tested in accordance with 43 CFR part 3170 Subpart 3172.

A variance is requested for the use of a flexible choke line from the BOP to Choke Manifold. Coflex hoses are in compliance with API 16C and meets inspection and testing requirements. See attached for specs and hydrostatic test chart.

Y Are anchors required by manufacturer?

A multibowl or a unionized multibowl wellhead system will be employed. The wellhead and connection to the BOPE will meet all API 6A requirements. The BOP will be tested per 43 CFR part 3170 Subpart 3172 after installation on the surface casing which will cover testing requirements for a maximum of 30 days. If any seal subject to test pressure is broken the system must be tested. We will test the flange connection of the wellhead with a test port that is directly in the flange. We are proposing that we will run the wellhead through the rotary prior to cementing surface casing as discussed with the BLM on October 8, 2015.

See attached Schematics.

### BOP Break Testing Request

Oxy requests permission to adjust the BOP break testing (intermediate and production) requirements as per the agreement reached in the OXY/BLM meeting on April 4th, 2025. Please see BOP Break Testing Variance attachment for further details.

### Hammer Union Variance

Oxy requests permission for hammer unions behind the choke to be routed to the gas buster. The hammer unions will not be subject to wellbore pressure in compliance with API STD 53.

Oxy will use Cameron ADAPT wellhead system that uses an OEC top flange connection. This connection has been fully vetted and verified by API to Spec 6A and carries an API monogram.



## Oxy Blanket Design - Casing Design "A"



### 5. Mud Program & Drilling Conditions

Section	Depth - MD		Depth - TVD		Type	Weight (ppg)	Viscosity	Water Loss
	From (ft)	To (ft)	From (ft)	To (ft)				
Surface	0	1200	0	1200	Water-Based Mud	8.6 - 8.8	40-60	N/C
Intermediate	1200	13111*	1200	12775*	Saturated Brine-Based or Oil-Based Mud	8.0 - 10.0	35-45	N/C
Production	13111	23361	12775	12775	Water-Based or Oil-Based Mud	9.5 - 13.5	38-50	N/C

\*Curve could be in intermediate or production section\*

Sufficient mud materials to maintain mud properties and meet minimum lost circulation and weight increase requirements will be kept on location at all times. The following is a general list of products: Barite, Bentonite, Gypsum, Lime, Soda Ash, Caustic Soda, Nut Plug, Cedar Fiber, Cotton Seed Hulls, Drilling Paper, Salt Water Clay, CACL2. Oxy will use a closed mud system.

#### Drilling Blind Request

In the event total losses are encountered in the intermediate section, Oxy requests permission to drill blind due to depleted formations where risk of hydrocarbon kicks are unlikely.

- Oxy will first attempt to cure losses before proceeding with drilling blind
- Drilling blind will only be allowed in the Castille and formations below
- While drilling blind, will monitor backside by filling-up on connections and utilize gas monitors
- Depths at which losses occurred and attempt to cure losses with relevant details (LCM sweep info, etc.) will be documented in the drillers log and Subsequent Reports to the BLM.
- If a well control event (hydrocarbon kick) occurs while drilling blind, the BLM will be notified after the well is secured and returned to static.

What will be used to monitor the loss or gain of fluid?	PVT/MD Totco/Visual Monitoring
---	--------------------------------

Pump high viscosity sweeps as needed for hole cleaning. The mud system will be monitored visually/manually as well as with an electronic PVT. The necessary mud products for additional weight and fluid loss control will be on location at all times. Appropriately weighted mud will be used to isolate potential gas, oil, and water zones until such time as casing can be cemented into place for zonal isolation.



# Oxy Blanket Design - Casing Design "A"



## 6. Wellbore Diagram(s)

### Design Variation "A1"

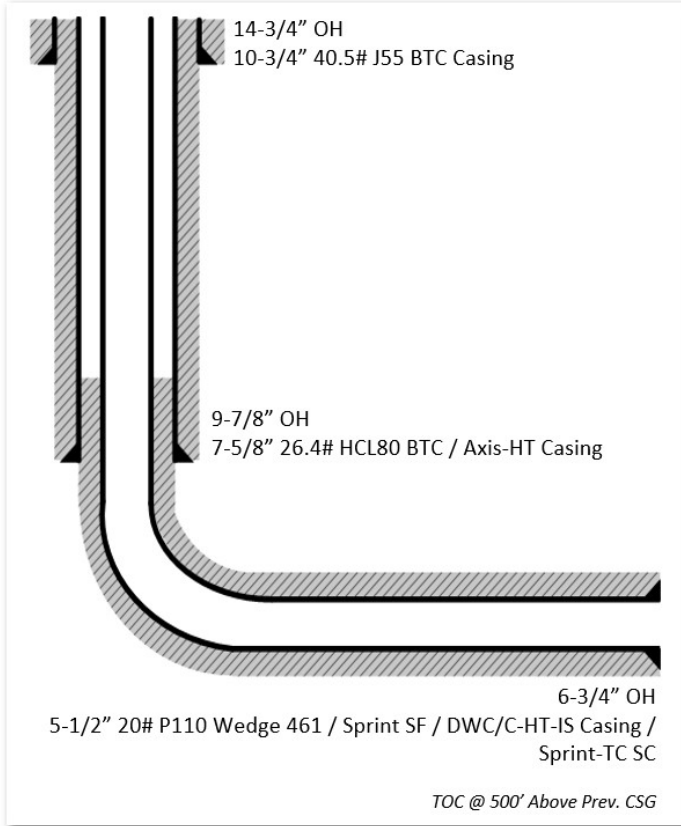

### Design Variation "A2"

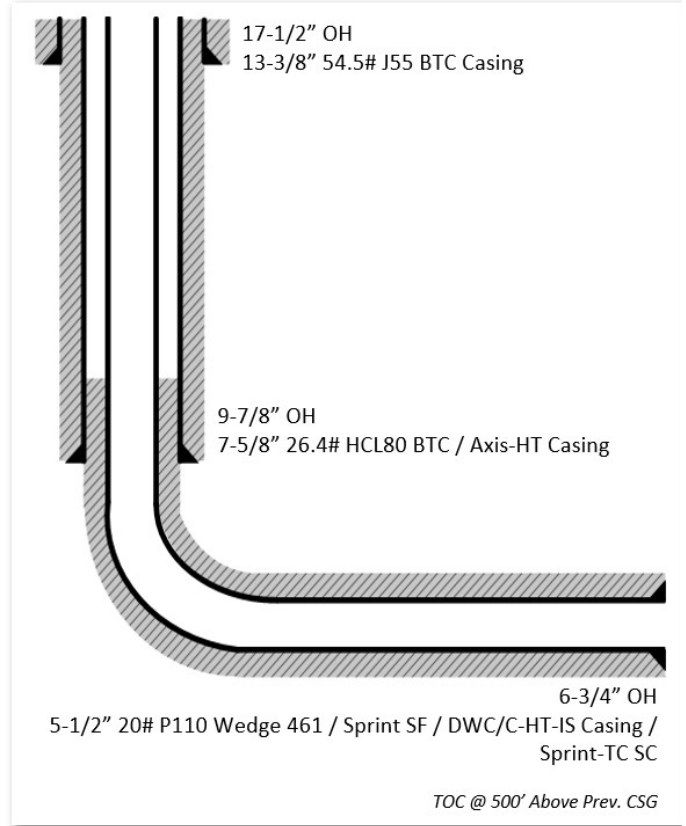



# Oxy Blanket Design - Casing Design "A"



## 7. Landmark StressCheck Screenshots – Triaxial Output

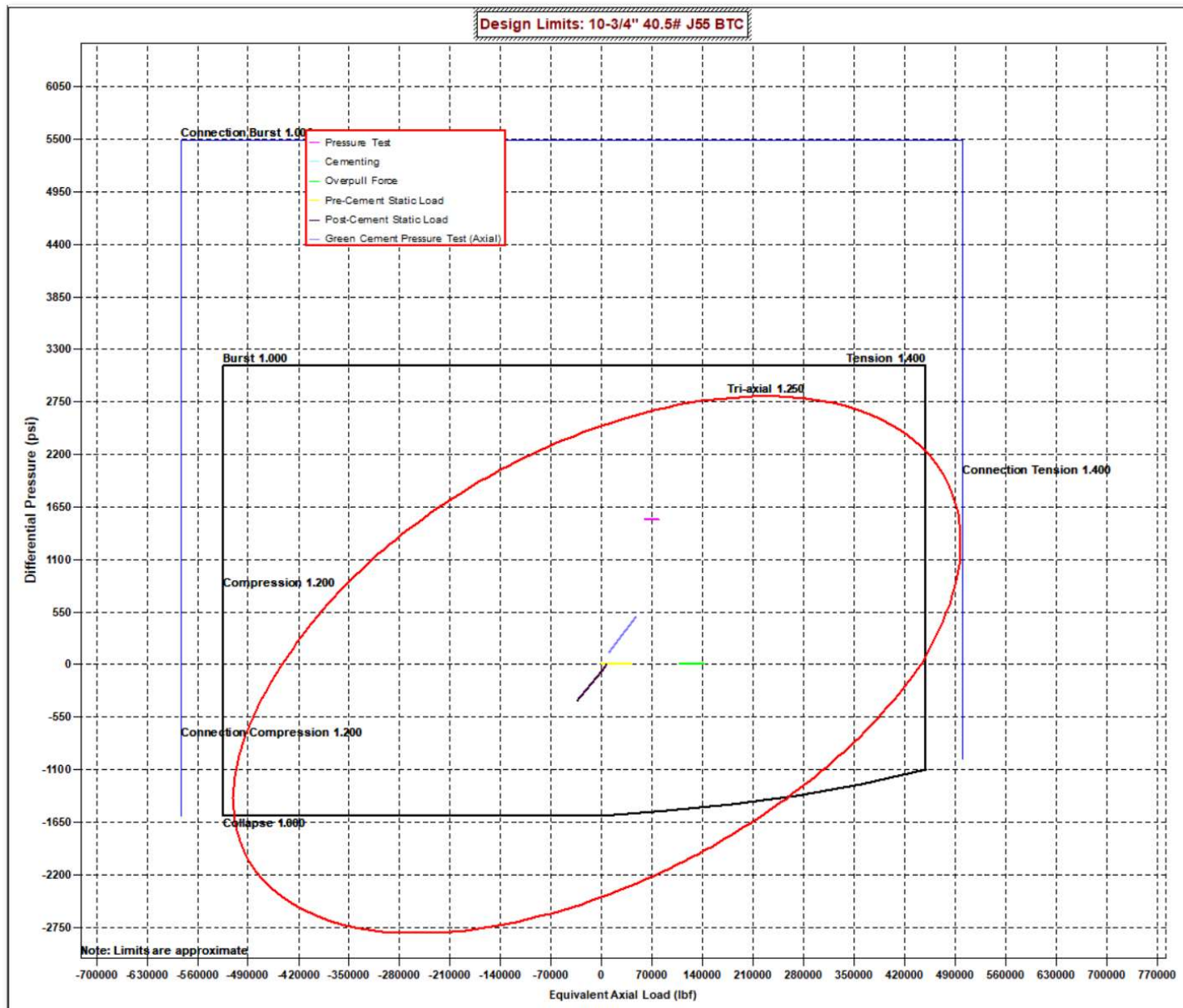



# Oxy Blanket Design - Casing Design "A"

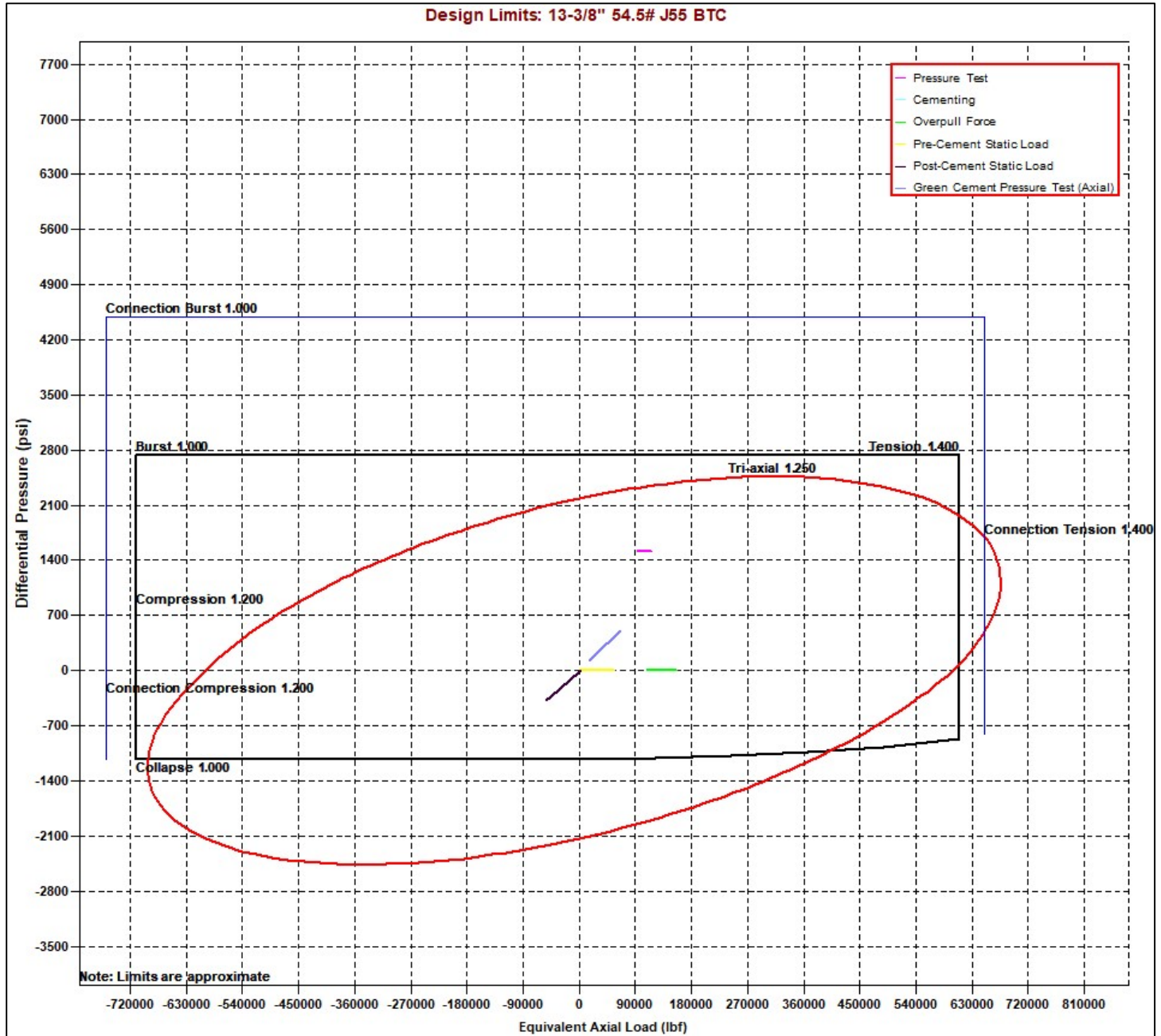



# Oxy Blanket Design - Casing Design "A"



Design Limits: 7-5/8" 26.4# HC-L80 BTC

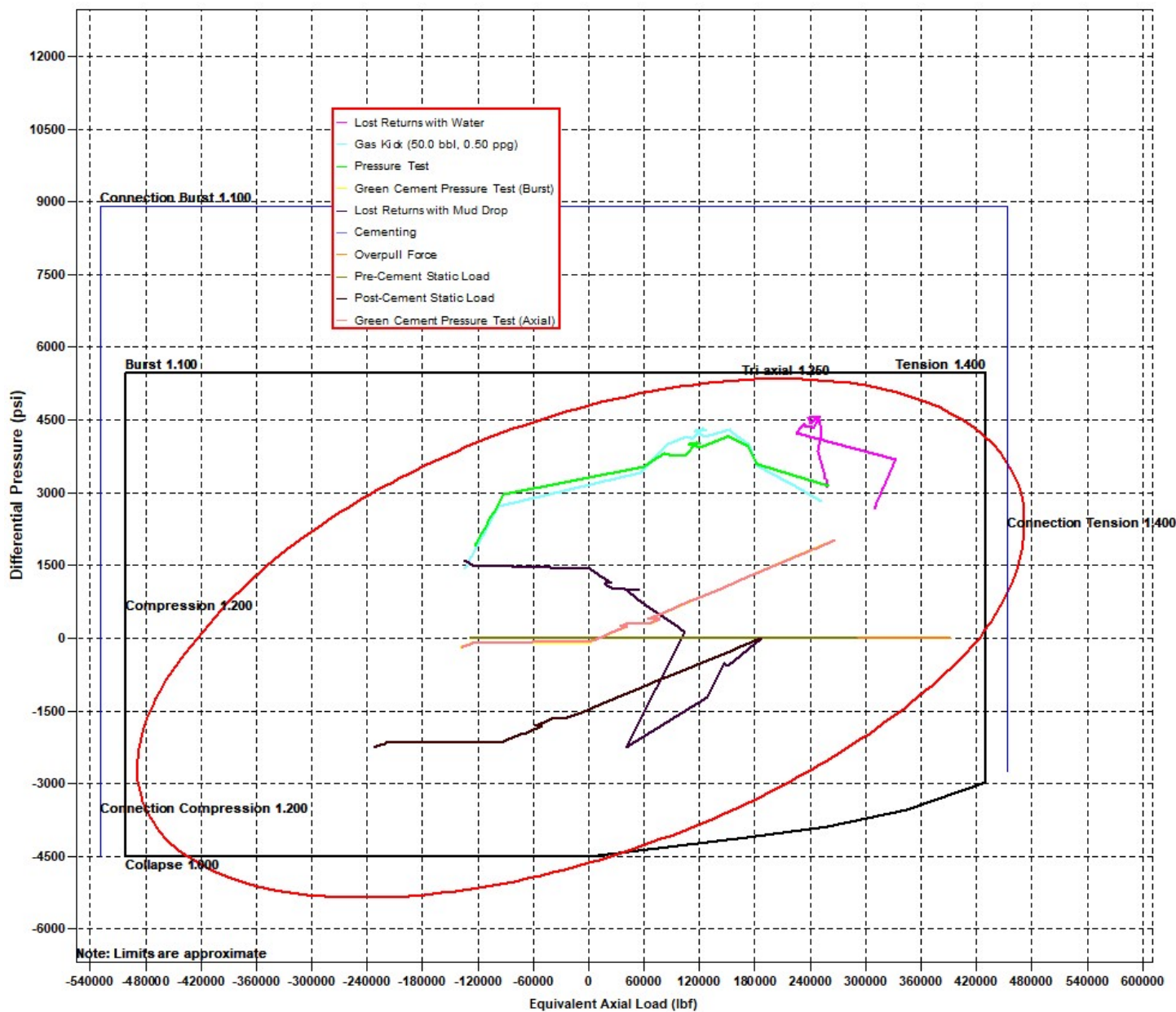



# Oxy Blanket Design - Casing Design "A"



Design Limits: 5-1/2" 20# P110 Sprint SF

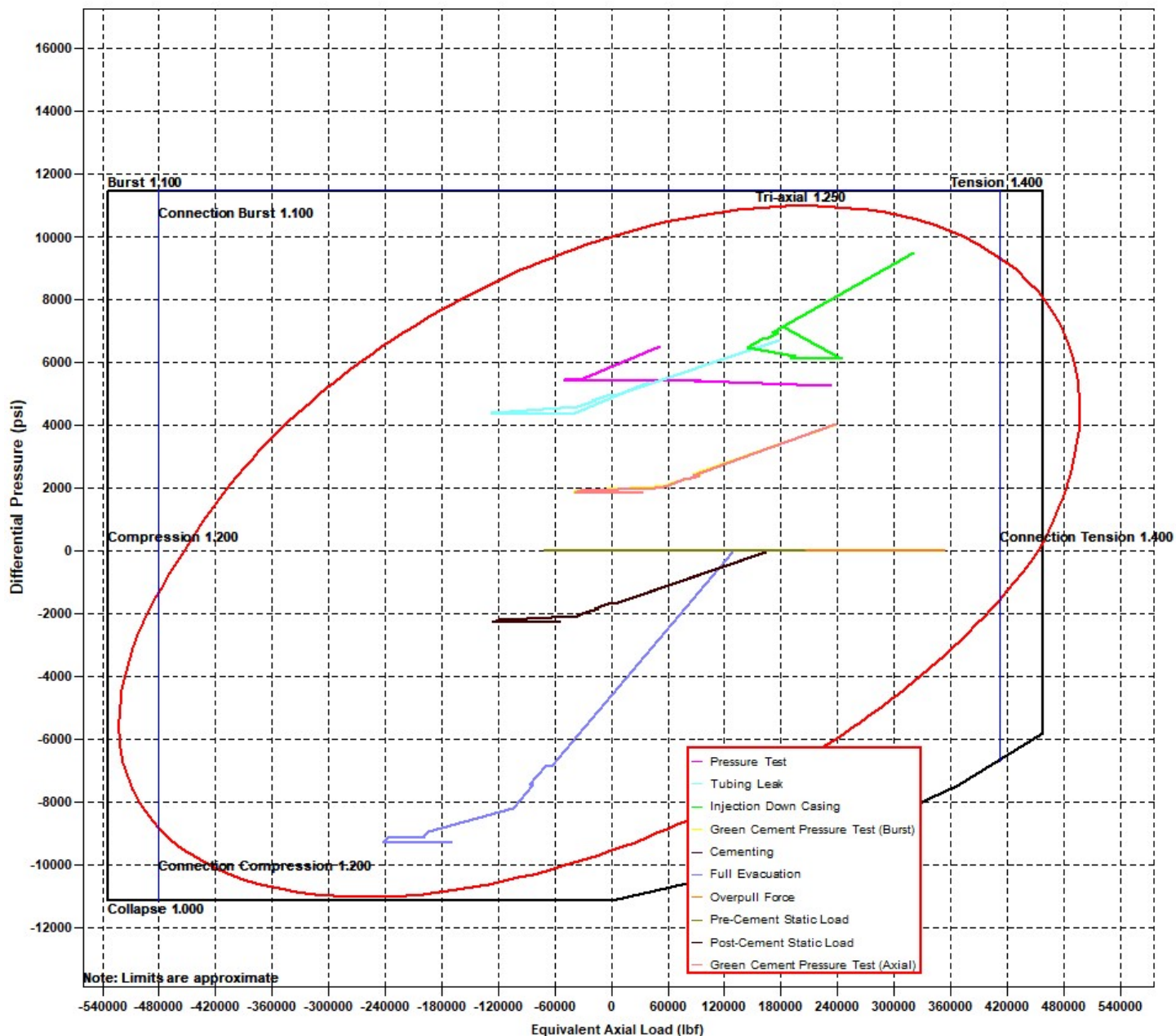



# Oxy Blanket Design - Casing Design "A"



## 8. Landmark StressCheck Screenshots – Inputs for Intermediate CSG Load Cases

### Burst Load Cases

Burst Loads Data	
<b>Drilling Load:</b>	<b>Lost Returns with Water</b>
Fracture at Shoe (MD= 13111.00 ft):	10591 psi
Mud/Water Interface, MD:	0.00 ft
Mud Weight	11.28 ppg
Assigned External Pressure:	Fluid Gradients (w/ Pore Pressure)
<b>Drilling Load:</b>	<b>Gas Kick Profile</b>
Influx Depth, MD:	23361.00 ft
Kick Volume:	50.0 bbl
Kick Intensity	0.50 ppg
Maximum Mud Weight:	13.50 ppg
Kick Gas Gravity:	0.55 (0.1159 psi/ft @ 182 °F & 9291 psi)
Fracture at Shoe (MD= 13111.00 ft):	10591 psi
Drill Pipe OD:	5.000 in
Collar OD:	5.500 in
Collar Length:	200.00 ft
Assigned External Pressure:	Fluid Gradients (w/ Pore Pressure)
<b>Drilling Load:</b>	<b>Pressure Test</b>
Test Pressure:	3120 psi
Mud Weight:	10.00 ppg
Assigned External Pressure:	Fluid Gradients (w/ Pore Pressure)
<b>Drilling Load:</b>	<b>Green Cement Pressure Test</b>
Test Pressure:	2000 psi
Mud Weight at Shoe:	10.00 ppg
TOC, MD:	25.00 ft
Lead Slurry Density:	13.30 ppg
Tail Slurry Density:	13.30 ppg
Tail Slurry Length:	5906.00 ft
Displacement Fluid Density:	10.00 ppg
Float Collar Depth, MD:	12800.00 ft
<b>External Pressure:</b>	<b>Fluid Gradients (w/ Pore Pressure)</b>
TOC, MD:	25.00 ft
Prior Shoe, MD:	1200.00 ft
Mud Weight Above TOC:	10.00 ppg
Fluid Gradient Below TOC:	8.33 ppg
Wellhead Pressure:	13 psi
Pore Pressure In Open Hole:	Yes



# Oxy Blanket Design - Casing Design "A"



## Collapse Load Cases

Collapse Loads Data	
<b>Drilling Load: Cementing</b>	
Mud Weight at Shoe:	10.00 ppg
TOC, MD:	25.00 ft
Lead Slurry Density:	13.30 ppg
Tail Slurry Density:	13.30 ppg
Tail Slurry Length:	5906.00 ft
Displacement Fluid Density:	10.00 ppg
Float Collar Depth, MD:	12800.00 ft
Assigned External Pressure:	Fluid Gradients (w/ Pore Pressure)
<b>Drilling Load: Lost Returns with Mud Drop</b>	
Lost Returns Depth, MD:	13110.89 ft
Pore Pressure at Lost Returns Depth:	8183 psi
Pore Pressure Gradient at Lost Returns Depth:	12.33 ppg
Mud Weight:	13.50 ppg
Mud Drop Level, MD:	1106.39 ft
Assigned External Pressure:	Fluid Gradients (w/ Pore Pressure)
<b>External Pressure: Fluid Gradients (w/ Pore Pressure)</b>	
TOC, MD:	25.00 ft
Prior Shoe, MD:	1200.00 ft
Fluid Gradient Above TOC:	10.00 ppg
Fluid Gradient Below TOC:	10.00 ppg
Wellhead Pressure:	13 psi
Pore Pressure In Open Hole Below TOC:	No

## Axial Load Cases

Axial Loads Data	
Overpull Force:	100000 lbf
Pre-Cement Static Load:	Yes
Pickup Force:	0 lbf
Post-Cement Static Load:	Yes
Green Cement Pressure Test:	2000 psi
Service Loads:	Yes



# Oxy Blanket Design - Casing Design "A"



## 9. Landmark StressCheck Screenshot – Int. Casing Triaxial Results Table (Pressure Test)

StressCheck - [Triaxial Results - Blanket Design A1]\*

File Edit Wellbore Tubular View Composer Tools Window Help

7 5/8" Intermediate Casing

Pressure Test

Depth (MD) (ft)	Axial Force (lbf)		Equivalent Axial Load (lbf)	Bending Stress at OD (psi)	Absolute Safety Factor				Temperature (°F)	Pressure (psi)		Addtl Pickup To Prevent Buck. (lbf)	Buckled Length (ft)
	Apparent (w/Bending)	Actual (w/o Bending)			Triaxial	Burst	Collapse (V)	Axial		Internal	External		
28	12300	-142410	-17423	-94936	16622.5	1.79	2.10	N/A	(4.09)	178	9505	6732	
29	12400	-149639	-24652	-100590	16622.5	1.87	2.25	N/A	(3.89)	179	9555	6970	
30	12400	-149640	-24653	-100591	16622.5	1.87	2.25	N/A	(3.89)	179	9555	6970	
31	12500	-156448	-31461	-105919	16622.5	1.95	2.42	N/A	(3.72)	180	9603	7193	
32	12500	-156449	-31462	-105920	16622.5	1.95	2.42	N/A	(3.72)	180	9603	7193	
33	12550	-159630	-34643	-108410	16622.5	1.99	2.50	N/A	(3.64)	180	9625	7298	
34	12550	-159631	-34644	-108411	16622.5	1.99	2.50	N/A	(3.64)	180	9625	7298	
35	12600	-162630	-37643	-110759	16622.5	2.03	2.59	N/A	(3.58)	180	9646	7396	
36	12600	-162631	-37644	-110760	16622.5	2.03	2.59	N/A	(3.58)	180	9646	7396	
37	12650	-165426	-40439	-112949	16622.5	2.07	2.67	N/A	(3.52)	181	9665	7488	
38	12650	-165427	-40440	-112950	16622.5	2.07	2.67	N/A	(3.52)	181	9665	7488	
39	12700	-167997	-43010	-114963	16622.5	2.10	2.76	N/A	(3.46)	181	9683	7573	
40	12700	-167998	-43011	-114963	16622.5	2.10	2.76	N/A	(3.46)	181	9683	7573	
41	12750	-170322	-45335	-116784	16622.5	2.13	2.84	N/A	(3.41)	181	9699	7649	
42	12750	-170323	-45336	-116785	16622.5	2.13	2.84	N/A	(3.41)	181	9699	7649	
43	12800	-172385	-47398	-118401	16622.5	2.16	2.91	N/A	(3.37)	181	9714	7717	
44	12800	-172386	-47399	-118401	16622.5	2.16	2.91	N/A	(3.37)	181	9714	7717	
45	12850	-174169	-49183	-119799	16622.5	2.19	2.98	N/A	(3.34)	182	9726	7775	
46	12850	-174170	-49183	-119800	16622.5	2.19	2.98	N/A	(3.34)	182	9726	7775	
47	12900	-175662	-50675	-120969	16622.5	2.21	3.04	N/A	(3.31)	182	9736	7824	
48	12950	-176851	-51864	-121901	16622.5	2.23	3.09	N/A	(3.29)	182	9745	7863	
49	13000	-177727	-52740	-122588	16622.5	2.24	3.13	N/A	(3.27)	182	9751	7892	
50	13000	-177728	-52741	-122588	16622.5	2.24	3.13	N/A	(3.27)	182	9751	7892	
51	13050	-178285	-53298	-123025	16622.5	2.25	3.15	N/A	(3.26)	182	9755	7910	
52	13111	-178527	-53540	-123214	16622.5	2.25	3.16	N/A	(3.26)	182	9756	7918	
53													
54													
55													
56													

( ) Compression  
(V) Vector Collapse Safety Factor

Internal Pressure = Surface Pressure + Hydrostatic = 9756 psi  
 External Pressure = Fluid Gradient w/ Pore Pressure = 7918 psi  
 Burst SF = 3.16

NOTE: Specific load case inputs for the pressure test can be seen in **Section 8** above. The test pressure does not exceed 70% of the minimum internal yield.



# Oxy Blanket Design - Casing Design "A"



## 10. Intermediate Non-API Casing Spec Sheet



### Technical Data Sheet

7 5/8" 26.40 lbs/ft. L80HC - Axis HT

#### Mechanical Properties

Minimum Yield Strength	psi.	80,000
Maximum Yield Strength	psi.	95,000
Minimum Tensile Strength	psi.	95,000

#### Dimensions

		<i>Pipe</i>	<i>AXIS HT</i>
Outside Diameter	in.	7.625	8.500
Wall Thickness	in.	0.328	-
Inside Diameter	in.	6.969	-
Standard Drift	in.	6.844	6.844
Alternate Drift	in.	-	-
Plain End Weight	lbs/ft.	-	-
Nominal Linear Weight	lbs/ft.	26.40	-

#### Performance

		<i>Pipe</i>	<i>AXIS HT</i>
Minimum Collapse Pressure	psi.	4,320	-
Minimum Internal Yield Pressure	psi.	6,020	6,020
Minimum Pipe Body Yield Strength	lbs.	602 x 1,000	-
Joint Strength	lbs.	-	635 x 1,000

#### Make-Up Torques

		<i>Pipe</i>	<i>AXIS HT</i>
Optimum Make-Up Torque	ft/lbs.	-	8,000
Maximum Operational Torque	ft/lbs.	-	25,000

Disclaimer: The content of this Technical Data Sheet is for general information only and does not guarantee performance and/or accuracy, which can only be determined by a professional expert with the specific installation and operation parameters. Information printed or downloaded may not be current and no longer in control by Axis Pipe and Tube. Anyone using the information herein does so at his or her own risk. To verify that you have the latest technical information, please contact Axis Pipe and Tube Technical Sales +1 (979) 599-7600, [www.axispipeandtube.com](http://www.axispipeandtube.com)



# Oxy Blanket Design - Casing Design "A"



## 11. Production Non-API Casing Spec Sheets

Printed on: 11/09/2021



**TenarisHydril Wedge  
461<sup>®</sup> MS**



Coupling	Pipe Body
Grade: P110-4CY	Grade: P110-4CY
Body: White	1st Band: White
1st Band: Pale Green	2nd Band: Pale Green
2nd Band: -	3rd Band: Pale Green
3rd Band: -	4th Band: -
	5th Band: -
	6th Band: -

Outside Diameter	5.500 in.	Wall Thickness	0.361 in.	Grade	P110-4CY
Min. Wall Thickness	87.50 %	Pipe Body Drift	API Standard	Type	Casing
Connection OD Option	MS				

### Pipe Body Data

Geometry		Performance	
Nominal OD	5.500 in.	Wall Thickness	0.361 in.
Nominal Weight	20 lb/ft	Plain End Weight	19.83 lb/ft
Drift	4.653 in.	OD Tolerance	API
Nominal ID	4.778 in.		
		Body Yield Strength	729 x1000 lb
		Min. Internal Yield Pressure	14,360 psi
		SMYS	125,000 psi
		Collapse Pressure	12,300 psi

### Connection Data

Geometry		Performance		Make-Up Torques	
Connection OD	6.050 in.	Tension Efficiency	100 %	Minimum	17,000 ft-lb
Coupling Length	7.714 in.	Joint Yield Strength	729 x1000 lb	Optimum	18,000 ft-lb
Connection ID	4.778 in.	Internal Pressure Capacity	14,360 psi	Maximum	21,600 ft-lb
Make-up Loss	3.775 in.	Compression Efficiency	100 %		
Threads per inch	3.40	Compression Strength	729 x1000 lb	Operation Limit Torques	
Connection OD Option	Ms	Max. Allowable Bending	104 °/100 ft	Operating Torque	43,000 ft-lb
		External Pressure Capacity	12,300 psi	Yield Torque	51,000 ft-lb
		Coupling Face Load	273,000 lb	Buck-On	
				Minimum	21,600 ft-lb
				Maximum	23,100 ft-lb

### Notes

This connection is fully interchangeable with:  
 Wedge 441@ - 5.5 in. - 0.304 / 0.361 in.  
 Wedge 461@ - 5.5 in. - 0.304 / 0.415 / 0.476 in.  
 Connections with Dopeless® Technology are fully compatible with the same connection in its Standard version  
 In October 2019, TenarisHydril Wedge XP® 2.0 was renamed TenarisHydril Wedge 461™. Product dimensions and properties remain identical and both connections are fully interchangeable

For the latest performance data, always visit our website: [www.tenaris.com](http://www.tenaris.com)

Tenaris has issued this document for general information only, and the information in this document, including, without limitation, any pictures, drawings or designs ("Information") is not intended to constitute professional or any other type of advice or recommendation and is provided on an "as is" basis. No warranty is given. Tenaris has not independently verified any information –if any- provided by the user in connection with, or for the purpose of, the Information contained hereunder. The use of the Information is at user's own risk and Tenaris does not assume any responsibility or liability of any kind for any loss, damage or injury resulting from, or in connection with any Information contained hereunder or any use thereof. The information in this document is subject to change or modification without notice. Tenaris's products and services are subject to Tenaris's standard terms and conditions or otherwise to the terms resulting from the respective contracts of sale or services, as the case may be, between petitioner and Tenaris. For more complete information please contact a Tenaris's representative or visit our website at [www.tenaris.com](http://www.tenaris.com). ©Tenaris 2021. All rights reserved.



# Oxy Blanket Design - Casing Design "A"



Generated on May 21, 2024



## CONNECTION DATA SHEET

OD: 5.500 in.      Grade: P110  
 Weight: 20.00 lb/ft      Drift: 4.653 in. (API)  
 Wall Th.: 0.361 in.

### VAM® SPRINT-SF

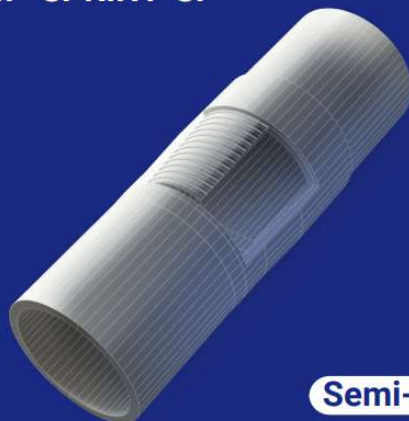

**Semi-Flush**

#### Field Torque Values

##### Make-up Torque (ft-lb)

- 20,000 MIN
- 22,500 OPTI
- 25,000 MAX

##### Torque with Sealability (ft-lb)

- 36,000 MTS

##### Locked Flank Torque (ft-lb)

- 4,500 MIN
- 15,750 MAX

(2) MTS: Maximum Torque with Sealability.

#### PIPE BODY PROPERTIES

Nominal OD	5.500	in.
Nominal ID	4.778	in.
Nominal Wall Thickness	0.361	in.
Minimum Wall Thickness	87.5	%
Nominal Weight (API)	20.00	lb/ft
Plain End Weight	19.83	lb/ft
Drift	4.653	in.
Grade Type	API 5CT	
Minimum Yield Strength	110	ksi
Maximum Yield Strength	140	ksi
Minimum Ultimate Tensile Strength	125	ksi
Pipe Body Yield Strength	641	klb
Internal Yield Pressure	12,640	psi
Collapse Pressure	11,100	psi

#### CONNECTION PROPERTIES

Connection Type	Semi-Premium Integral	Semi-Flu
Nominal Connection OD	5.783	in.
Nominal Connection ID	4.718	in.
Make-up Loss	5.965	in.
Tension Efficiency	90	% Pipe Body
Compression Efficiency	90	% Pipe Body
Internal Pressure Efficiency	100	% Pipe Body
External Pressure Efficiency	100	% Pipe Body

#### JOINT PERFORMANCES

Tension Strength	577	klb
Compression Strength	577	klb
Internal Pressure Resistance	12,640	psi
External Pressure Resistance	11,100	psi
Maximum Bending, Structural	78	°/100 ft
Maximum Bending, with Sealability(1)	30	°/100 ft

(1) Sealability rating demonstrated as per API RP-5C5 / ISO 13679



**BOOST YOUR EFFICIENCY, REDUCE COSTS  
 AND ENSURE 100% WELL INTEGRITY WITH  
 VAM® FIELD SERVICE**

Scan the QR code  
to contact us



The information available on this Site ("Information") is offered for general information. It is supposed to be correct at the time of publishing on the Site but is not intended to constitute professional advice and is provided 'as is'. Vallourec does not guarantee the completeness and accuracy of this information. Under no circumstances will Vallourec be liable for damage, liability of any kind, or any loss or injury that may result from the credibility given to this information or its use. The information may be amended, corrected, at any time by Vallourec without warning. Vallourec's products and services are subject to Vallourec's The Information may be amended, corrected, and/or supplemented at any time by Vallourec without warning, standard terms and conditions or otherwise to the terms resulting from the respective contracts of sale or services.



# Oxy Blanket Design - Casing Design "A"



**DWC/C-HT-IS**

## Connection Data Sheet

OD (in.)	WEIGHT (lbs./ft.)	WALL (in.)	GRADE	API DRIFT (in.)	RBW%	CONNECTION
5.500	Nominal: 20.00 Plain End: 19.83	0.361	‡VST P110MY	4.653	87.5	DWC/C-HT-IS

PIPE PROPERTIES		
Nominal OD	5.500	in.
Nominal ID	4.778	in.
Nominal Area	5.828	sq.in.
Grade Type	API 5CT	
Min. Yield Strength	125	ksi
Max. Yield Strength	140	ksi
Min. Tensile Strength	135	ksi
Yield Strength	729	klb
Ultimate Strength	787	klb
Min. Internal Yield Pressure	14,360	psi
Collapse Pressure	12,090	psi

CONNECTION PROPERTIES		
Connection Type	Semi-Premium T&C	
Connection OD (nom)	6.050	in.
Connection ID (nom)	4.778	in.
Make-Up Loss	4.125	in.
Coupling Length	9.250	in.
Critical Cross Section	5.828	sq.in.
Tension Efficiency	89.1%	of pipe
Compression Efficiency	88.0%	of pipe
Internal Pressure Efficiency	86.1%	of pipe
External Pressure Efficiency	100.0%	of pipe

CONNECTION PERFORMANCES		
Yield Strength	649	klb
Parting Load	729	klb
Compression Rating	641	klb
Min. Internal Yield Pressure	12,360	psi
External Pressure Resistance	12,090	psi
Maximum Uniaxial Bend Rating	91.7	°/100 ft
Reference String Length w 1.4 Design Factor	22,890	ft.

FIELD TORQUE VALUES		
Min. Make-up torque	16,600	ft.lb
Opti. Make-up torque	17,950	ft.lb
Max. Make-up torque	19,300	ft.lb
Min. Shoulder Torque	1,660	ft.lb
Max. Shoulder Torque	13,280	ft.lb
Max. Delta Turn	0.200	Turns
‡Maximum Operational Torque	23,800	ft.lb
‡Maximum Torsional Value (MTV)	26,180	ft.lb

‡ Maximum Operational Torque and Maximum Torsional Value only valid with Vallourec P110MY Material.  
 ‡ P110MY - Coupling Min Yield Strength is 110ksi and Coupling Max Yield is 125ksi.

"VST = Vallourec Star as the mill source for the pipe, "P110EC" is the grade name"

Need Help? Contact: [tech.support@vam-usa.com](mailto:tech.support@vam-usa.com)

For detailed information on performance properties, refer to DWC Connection Data Notes on following page(s).

Connection specifications within the control of VAM USA were correct as of the date printed. Specifications are subject to change without notice. Certain connection specifications are dependent on the mechanical properties of the pipe. Mechanical properties of mill proprietary pipe grades were obtained from mill publications and are subject to change. Properties of mill proprietary grades should be confirmed with the mill. Users are advised to obtain current connection specifications and verify pipe mechanical properties for each application.

All information is provided by VAM USA or its affiliates at user's sole risk, without liability for loss, damage or injury resulting from the use thereof; and on an "AS IS" basis without warranty or representation of any kind, whether express or implied, including without limitation any warranty of merchantability, fitness for purpose or completeness. This document and its contents are subject to change without notice. In no event shall VAM USA or its affiliates be responsible for any indirect, special, incidental, punitive, exemplary or consequential loss or damage (including without limitation, loss of use, loss of bargain, loss of revenue, profit or anticipated profit) however caused or arising, and whether such losses or damages were foreseeable or VAM USA or its affiliates was advised of the possibility of such damages.

03/04/2024 08:36:50 PM





## Oxy Blanket Design - Casing Design "A"



VAM USA  
 2107 CityWest Boulevard Suite 1300  
 Houston, TX 77042  
 Phone: 713-479-3200  
 Fax: 713-479-3234  
 VAM<sup>®</sup> USA Sales E-mail: [VAMUSAsales@vam-usa.com](mailto:VAMUSAsales@vam-usa.com)  
 Tech Support Email: [tech.support@vam-usa.com](mailto:tech.support@vam-usa.com)

### DWC Connection Data Sheet Notes:

1. DWC connections are available with a seal ring (SR) option.
2. All standard DWC/C connections are interchangeable for a given pipe OD. DWC connections are interchangeable with DWC/C-SR connections of the same OD and wall.
3. Connection performance properties are based on nominal pipe body and connection dimensions.
4. DWC connection internal and external pressure resistance is calculated using the API rating for buttress connections. API Internal pressure resistance is calculated from formulas 31, 32, and 35 in the API Bulletin 5C3.
5. DWC joint strength is the minimum pipe body yield strength multiplied by the connection critical area.
6. API joint strength is for reference only. It is calculated from formulas 42 and 43 in the API Bulletin 5C3.
7. Bending efficiency is equal to the compression efficiency.
8. The torque values listed are recommended. The actual torque required may be affected by field conditions such as temperature, thread compound, speed of make-up, weather conditions, etc.
9. Connection yield torque is not to be exceeded.
10. Reference string length is calculated by dividing the joint strength by both the nominal weight in air and a design factor (DF) of 1.4. These values are offered for reference only and do not include load factors such as bending, buoyancy, temperature, load dynamics, etc.
11. DWC connections will accommodate API standard drift diameters.
12. DWC/C family of connections are compatible with API Buttress BTC connections. Please contact [tech.support@vam-usa.com](mailto:tech.support@vam-usa.com) for details on connection ratings and make-up.

Connection specifications within the control of VAM USA were correct as of the date printed. Specifications are subject to change without notice. Certain connection specifications are dependent on the mechanical properties of the pipe. Mechanical properties of mill proprietary pipe grades were obtained from mill publications and are subject to change. Properties of mill proprietary grades should be confirmed with the mill. Users are advised to obtain current connection specifications and verify pipe mechanical properties for each application.

All information is provided by VAM USA or its affiliates at user's sole risk, without liability for loss, damage or injury resulting from the use thereof; and on an "AS IS" basis without warranty or representation of any kind, whether express or implied, including without limitation any warranty of merchantability, fitness for purpose or completeness. This document and its contents are subject to change without notice. In no event shall VAM USA or its affiliates be responsible for any indirect, special, incidental, punitive, exemplary or consequential loss or damage (including without limitation, loss of use, loss of bargain, loss of revenue, profit or anticipated profit) however caused or arising, and whether such losses or damages were foreseeable or VAM USA or its affiliates was advised of the possibility of such damages.

03/04/2024 08:36:50 PM





# Oxy Blanket Design - Casing Design "A"



Generated on May 14, 2025



## CONNECTION DATA SHEET

OD: 5.500 in.      Grade: P110 EC  
 Weight: 20.00 lb/ft      Drift: 4.653 in. (API)  
 Wall Th.: 0.361 in.

### VAM® SPRINT-TC SC

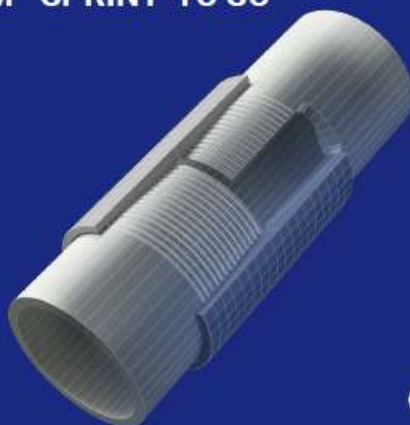

T&C

#### Field Torque Values

##### Make-up Torque (ft-lb)

- 23,000 MIN
- 24,000 OPTI
- 25,000 MAX

##### Torque with Sealability (ft-lb)

- 39,200 MTS

##### Locked Flank Torque (ft-lb)

- 1,200 MIN
- 16,800 MAX

(1) MTS: Maximum Torque with Sealability  
 (2) Note: Thread compound must be applied as a thin even layer

#### PIPE BODY PROPERTIES

Nominal OD	5.500	in.
Nominal ID	4.778	in.
Nominal Wall Thickness	0.361	in.
Minimum Wall Thickness	87.5	%
Nominal Weight (API)	20.00	lb/ft
Plain End Weight	19.83	lb/ft
Drift	4.653	in.
Grade Type	High Yield	
Minimum Yield Strength	125	ksi
Maximum Yield Strength	140	ksi
Minimum Ultimate Tensile Strength	135	ksi
Pipe Body Yield Strength	729	klb
Internal Yield Pressure	14,360	psi
Collapse Pressure	12,090	psi

#### CONNECTION PROPERTIES

Connection Type	Semi-Premium Threaded & Coupled	
Nominal Connection OD	5.900	in.
Nominal Connection ID	4.830	in.
Make-up Loss	3.973	in.
Coupling Length	8.296	in.
Tension Efficiency	100	% Pipe Body
Compression Efficiency	100	% Pipe Body
Internal Pressure Efficiency	100	% Pipe Body
External Pressure Efficiency	100	% Pipe Body

#### JOINT PERFORMANCES

Tension Strength	729	klb
Compression Strength	729	klb
Internal Pressure Resistance	14,360	psi
External Pressure Resistance	12,090	psi
Maximum Bending, Structural	104	°/100 ft
Maximum Bending, with Sealability	30	°/100 ft
Maximum Load on Coupling Face	227	klb

(4) Sealability rating demonstrated as per API RP 5C6 / ISO 13679



**BOOST YOUR EFFICIENCY, REDUCE COSTS AND ENSURE 100% WELL INTEGRITY WITH VAM® FIELD SERVICE**

Scan the QR code to contact us



The information available on this Site ("Information") is offered for general information. It is supposed to be correct at the time of publishing on the Site but is not intended to constitute professional advice and is provided "as is". Vallourec does not guarantee the completeness and accuracy of this information. Under no circumstances will Vallourec be liable for damage, liability of any kind, or any loss or injury that may result from the credibility given to this information or its use. The information may be amended, corrected, at any time by Vallourec without warning. Vallourec's products and services are subject to Vallourec's standard terms and conditions or otherwise to the terms resulting from the respective contracts of sale or services. The information may be amended, corrected, and/or supplemented at any time by Vallourec without warning.

# Oxy USA Inc. - Blanket Design Pad Document

## OXY - Blanket Design A

Pad Name: LSTTNK\_22S31E\_26\_2

SHL: 2448' FSL 2111' FEL, Sec 26, T22S-R31E

Oxy requests for the bellow wells to be approved for the two designs listed in the Blanket Design document (**Blanket Design A –OXY –3S Slim v8.0.**) The MDs and TVDs for all intervals are within the boundary conditions. The max inclination and DLS are also within the boundary conditions (directional plans attached separately for review.)

### 1. Blanket Design - Wells

Well Name	APD #	Surface		Intermediate		Production	
		MD	TVD	MD	TVD	MD	TVD
OLIVE WON UNIT 74H	10400096406	913	913	10233	10233	18911	10835
OLIVE WON UNIT 73H	10400096405	913	913	10090	10090	18813	10820
OLIVE WON UNIT 22H	10400096931	913	913	9711	9711	18395	10370
OLIVE WON UNIT 23H	10400096933	913	913	9685	9685	18386	10375
OLIVE WON UNIT 2H	10400096928	913	913	9223	9223	17905	9770
OLIVE WON UNIT 3H	10400096402	913	913	9049	9049	17774	9780

### 2. Review Criteria Table

	Y or N
Is casing new? If used, attach certification as required in 43 CFR 3160	Y
Does casing meet API specifications? If no, attach casing specification sheet.	Y
Is premium or uncommon casing planned? If yes attach casing specification sheet.	Y
Does the above casing design meet or exceed BLM’s minimum standards? If not provide justification (loading assumptions, casing design criteria).	Y
Will the intermediate pipe be kept at a minimum 1/3 fluid filled to avoid approaching the collapse pressure rating of the casing?	Y
Is well located within Capitan Reef?	N
If yes, does production casing cement tie back a minimum of 50’ above the Reef?	
Is well within the designated 4 string boundary.	
Is well located in SOPA but not in R-111-Q?	Y
If yes, are the first 2 strings cemented to surface and 3 <sup>rd</sup> string cement tied back 500’ into previous casing?	Y
Is well located in R-111-Q and SOPA?	N
If yes, are the first three strings cemented to surface?	
Is 2 <sup>nd</sup> string set 100’ to 600’ below the base of salt?	
Is well located in high Cave/Karst?	N
If yes, are there two strings cemented to surface? (For 2 string wells) If yes, is there a contingency casing if lost circulation occurs?	
Is well located in critical Cave/Karst?	N
If yes, are there three strings cemented to surface?	

### 3. Geologic Formations

Formation	MD-RKB (ft)	TVD-RKB (ft)	Expected Fluids
Rustler	843	843	
Salado	1126	1126	Salt
Marker Bed 126	2000	2000	Salt
Castile	3020	3020	Salt
Delaware	4434	4434	Oil/Gas/Brine
Bell Canyon	4481	4481	Oil/Gas/Brine
Cherry Canyon	5347	5343	Oil/Gas/Brine
Brushy Canyon	6591	6560	Losses
Bone Spring	8419	8348	Oil/Gas
Bone Spring 1st	9580	9483	Oil/Gas
Bone Spring 2nd	10139	10030	Oil/Gas
Bone Spring 3rd			Oil/Gas
Wolfcamp			Oil/Gas
Penn			Oil/Gas
Strawn			Oil/Gas

### 4. Cementing Program

Section	Stage	Slurry:	Sacks	Yield (ft <sup>3</sup> /ft)	Density (lb/gal)	Excess:	TOC	Placement	Description
Surface	1	Surface - Tail	954	1.33	14.8	100%	-	Circulate	Class C+Accel.
Int.	1	Intermediate 1S - Tail	455	1.68	13.2	5%	6,841	Circulate	Class C+Ret., Disper.
Int.	2	Intermediate 2S - Tail BH	1225	1.71	13.3	25%	-	Bradenhead	Class C+Accel.
Prod.	1	Production - Tail	520	1.84	13.3	25%	9,733	Circulate	Class C+Ret.

# **OXY**

**PRD NM DIRECTIONAL PLANS (NAD 1983)**

**Olive Won**

**Olive Won Unit 2H**

**ORIG HOLE**

**Plan: Permitting Plan**

## **Standard Planning Report**

**21 January, 2026**

## OXY Planning Report

<b>Database:</b>	HOPSPP	<b>Local Co-ordinate Reference:</b>	Well Olive Won Unit 2H
<b>Company:</b>	ENGINEERING DESIGNS	<b>TVD Reference:</b>	RKB=25' @ 3540.00ft
<b>Project:</b>	PRD NM DIRECTIONAL PLANS (NAD 1983)	<b>MD Reference:</b>	RKB=25' @ 3540.00ft
<b>Site:</b>	Olive Won	<b>North Reference:</b>	Grid
<b>Well:</b>	Olive Won Unit 2H	<b>Survey Calculation Method:</b>	Minimum Curvature
<b>Wellbore:</b>	ORIG HOLE		
<b>Design:</b>	Permitting Plan		

<b>Project</b> PRD NM DIRECTIONAL PLANS (NAD 1983)			
<b>Map System:</b>	US State Plane 1983	<b>System Datum:</b>	Mean Sea Level
<b>Geo Datum:</b>	North American Datum 1983		
<b>Map Zone:</b>	New Mexico Eastern Zone		Using geodetic scale factor

<b>Site</b> Olive Won			
<b>Site Position:</b>		<b>Northing:</b>	496,069.70 usft
<b>From:</b>	Map	<b>Easting:</b>	720,943.10 usft
<b>Position Uncertainty:</b>	0.00 ft	<b>Slot Radius:</b>	13.200 in
		<b>Latitude:</b>	32.362424
		<b>Longitude:</b>	-103.751643

<b>Well</b> Olive Won Unit 2H			
<b>Well Position</b>	+N/-S	0.00 ft	<b>Northing:</b> 495,911.34 usf
	+E/-W	0.00 ft	<b>Easting:</b> 722,258.80 usf
<b>Position Uncertainty</b>		6.00 ft	<b>Longitude:</b> -103.747385
<b>Grid Convergence:</b>		0.31 °	<b>Wellhead Elevation:</b> ft
			<b>Ground Level:</b> 3,515.00 ft

<b>Wellbore</b> ORIG HOLE					
Magnetics	Model Name	Sample Date	Declination (°)	Dip Angle (°)	Field Strength (nT)
	HDGM_FILE	11/13/2023	6.40	59.95	47,567.10000000

<b>Design</b> Permitting Plan				
<b>Audit Notes:</b>				
<b>Version:</b>	<b>Phase:</b>	PROTOTYPE	<b>Tie On Depth:</b>	0.00
<b>Vertical Section:</b>	<b>Depth From (TVD) (ft)</b>	<b>+N/-S (ft)</b>	<b>+E/-W (ft)</b>	<b>Direction (°)</b>
	2.00	0.00	0.00	189.18

<b>Plan Survey Tool Program</b>		<b>Date</b> 1/21/2026			
#	Depth From (ft)	Depth To (ft)	Survey (Wellbore)	Tool Name	Remarks
1	0.00	17,905.13	Permitting Plan (ORIG HOLE)	B005Mc_MWD+HRGM+SA MWD+HRGM+Sag+MSA	

<b>Plan Sections</b>										
Measured Depth (ft)	Inclination (°)	Azimuth (°)	Vertical Depth (ft)	+N/-S (ft)	+E/-W (ft)	Dogleg Rate (°/100ft)	Build Rate (°/100ft)	Turn Rate (°/100ft)	TFO (°)	Target
0.00	0.00	0.00	0.00	0.00	0.00	0.00	0.00	0.00	0.00	
4,481.00	0.00	0.00	4,481.00	0.00	0.00	0.00	0.00	0.00	0.00	
5,281.15	16.00	292.91	5,270.79	43.22	-102.26	2.00	2.00	0.00	292.91	
9,322.74	16.00	292.91	9,155.76	477.00	-1,128.57	0.00	0.00	0.00	0.00	
10,285.13	90.00	179.70	9,770.00	-93.41	-1,287.45	10.00	7.69	-11.76	-112.41	
17,905.13	90.00	179.70	9,770.00	-7,713.31	-1,247.05	0.00	0.00	0.00	0.00	PBHL (Olive Won)

# OXY

## Planning Report

<b>Database:</b>	HOPSPP	<b>Local Co-ordinate Reference:</b>	Well Olive Won Unit 2H
<b>Company:</b>	ENGINEERING DESIGNS	<b>TVD Reference:</b>	RKB=25' @ 3540.00ft
<b>Project:</b>	PRD NM DIRECTIONAL PLANS (NAD 1983)	<b>MD Reference:</b>	RKB=25' @ 3540.00ft
<b>Site:</b>	Olive Won	<b>North Reference:</b>	Grid
<b>Well:</b>	Olive Won Unit 2H	<b>Survey Calculation Method:</b>	Minimum Curvature
<b>Wellbore:</b>	ORIG HOLE		
<b>Design:</b>	Permitting Plan		

Planned Survey									
Measured Depth (ft)	Inclination (°)	Azimuth (°)	Vertical Depth (ft)	+N/-S (ft)	+E/-W (ft)	Vertical Section (ft)	Dogleg Rate (°/100ft)	Build Rate (°/100ft)	Turn Rate (°/100ft)
0.00	0.00	0.00	0.00	0.00	0.00	0.00	0.00	0.00	0.00
100.00	0.00	0.00	100.00	0.00	0.00	0.00	0.00	0.00	0.00
200.00	0.00	0.00	200.00	0.00	0.00	0.00	0.00	0.00	0.00
300.00	0.00	0.00	300.00	0.00	0.00	0.00	0.00	0.00	0.00
400.00	0.00	0.00	400.00	0.00	0.00	0.00	0.00	0.00	0.00
500.00	0.00	0.00	500.00	0.00	0.00	0.00	0.00	0.00	0.00
600.00	0.00	0.00	600.00	0.00	0.00	0.00	0.00	0.00	0.00
700.00	0.00	0.00	700.00	0.00	0.00	0.00	0.00	0.00	0.00
800.00	0.00	0.00	800.00	0.00	0.00	0.00	0.00	0.00	0.00
900.00	0.00	0.00	900.00	0.00	0.00	0.00	0.00	0.00	0.00
1,000.00	0.00	0.00	1,000.00	0.00	0.00	0.00	0.00	0.00	0.00
1,100.00	0.00	0.00	1,100.00	0.00	0.00	0.00	0.00	0.00	0.00
1,200.00	0.00	0.00	1,200.00	0.00	0.00	0.00	0.00	0.00	0.00
1,300.00	0.00	0.00	1,300.00	0.00	0.00	0.00	0.00	0.00	0.00
1,400.00	0.00	0.00	1,400.00	0.00	0.00	0.00	0.00	0.00	0.00
1,500.00	0.00	0.00	1,500.00	0.00	0.00	0.00	0.00	0.00	0.00
1,600.00	0.00	0.00	1,600.00	0.00	0.00	0.00	0.00	0.00	0.00
1,700.00	0.00	0.00	1,700.00	0.00	0.00	0.00	0.00	0.00	0.00
1,800.00	0.00	0.00	1,800.00	0.00	0.00	0.00	0.00	0.00	0.00
1,900.00	0.00	0.00	1,900.00	0.00	0.00	0.00	0.00	0.00	0.00
2,000.00	0.00	0.00	2,000.00	0.00	0.00	0.00	0.00	0.00	0.00
2,100.00	0.00	0.00	2,100.00	0.00	0.00	0.00	0.00	0.00	0.00
2,200.00	0.00	0.00	2,200.00	0.00	0.00	0.00	0.00	0.00	0.00
2,300.00	0.00	0.00	2,300.00	0.00	0.00	0.00	0.00	0.00	0.00
2,400.00	0.00	0.00	2,400.00	0.00	0.00	0.00	0.00	0.00	0.00
2,500.00	0.00	0.00	2,500.00	0.00	0.00	0.00	0.00	0.00	0.00
2,600.00	0.00	0.00	2,600.00	0.00	0.00	0.00	0.00	0.00	0.00
2,700.00	0.00	0.00	2,700.00	0.00	0.00	0.00	0.00	0.00	0.00
2,800.00	0.00	0.00	2,800.00	0.00	0.00	0.00	0.00	0.00	0.00
2,900.00	0.00	0.00	2,900.00	0.00	0.00	0.00	0.00	0.00	0.00
3,000.00	0.00	0.00	3,000.00	0.00	0.00	0.00	0.00	0.00	0.00
3,100.00	0.00	0.00	3,100.00	0.00	0.00	0.00	0.00	0.00	0.00
3,200.00	0.00	0.00	3,200.00	0.00	0.00	0.00	0.00	0.00	0.00
3,300.00	0.00	0.00	3,300.00	0.00	0.00	0.00	0.00	0.00	0.00
3,400.00	0.00	0.00	3,400.00	0.00	0.00	0.00	0.00	0.00	0.00
3,500.00	0.00	0.00	3,500.00	0.00	0.00	0.00	0.00	0.00	0.00
3,600.00	0.00	0.00	3,600.00	0.00	0.00	0.00	0.00	0.00	0.00
3,700.00	0.00	0.00	3,700.00	0.00	0.00	0.00	0.00	0.00	0.00
3,800.00	0.00	0.00	3,800.00	0.00	0.00	0.00	0.00	0.00	0.00
3,900.00	0.00	0.00	3,900.00	0.00	0.00	0.00	0.00	0.00	0.00
4,000.00	0.00	0.00	4,000.00	0.00	0.00	0.00	0.00	0.00	0.00
4,100.00	0.00	0.00	4,100.00	0.00	0.00	0.00	0.00	0.00	0.00
4,200.00	0.00	0.00	4,200.00	0.00	0.00	0.00	0.00	0.00	0.00
4,300.00	0.00	0.00	4,300.00	0.00	0.00	0.00	0.00	0.00	0.00
4,400.00	0.00	0.00	4,400.00	0.00	0.00	0.00	0.00	0.00	0.00
4,481.00	0.00	0.00	4,481.00	0.00	0.00	0.00	0.00	0.00	0.00
<b>Build 2°/100'</b>									
4,500.00	0.38	292.91	4,500.00	0.02	-0.06	-0.01	2.00	2.00	0.00
4,600.00	2.38	292.91	4,599.97	0.96	-2.28	-0.59	2.00	2.00	0.00
4,700.00	4.38	292.91	4,699.79	3.26	-7.71	-1.99	2.00	2.00	0.00
4,800.00	6.38	292.91	4,799.34	6.91	-16.34	-4.21	2.00	2.00	0.00
4,900.00	8.38	292.91	4,898.51	11.91	-28.17	-7.26	2.00	2.00	0.00
5,000.00	10.38	292.91	4,997.17	18.25	-43.19	-11.13	2.00	2.00	0.00
5,100.00	12.38	292.91	5,095.19	25.93	-61.36	-15.81	2.00	2.00	0.00
5,200.00	14.38	292.91	5,192.48	34.94	-82.67	-21.30	2.00	2.00	0.00

# OXY

## Planning Report

<b>Database:</b>	HOPSPP	<b>Local Co-ordinate Reference:</b>	Well Olive Won Unit 2H
<b>Company:</b>	ENGINEERING DESIGNS	<b>TVD Reference:</b>	RKB=25' @ 3540.00ft
<b>Project:</b>	PRD NM DIRECTIONAL PLANS (NAD 1983)	<b>MD Reference:</b>	RKB=25' @ 3540.00ft
<b>Site:</b>	Olive Won	<b>North Reference:</b>	Grid
<b>Well:</b>	Olive Won Unit 2H	<b>Survey Calculation Method:</b>	Minimum Curvature
<b>Wellbore:</b>	ORIG HOLE		
<b>Design:</b>	Permitting Plan		

Planned Survey									
Measured Depth (ft)	Inclination (°)	Azimuth (°)	Vertical Depth (ft)	+N/-S (ft)	+E/-W (ft)	Vertical Section (ft)	Dogleg Rate (°/100ft)	Build Rate (°/100ft)	Turn Rate (°/100ft)
5,281.15	16.00	292.91	5,270.79	43.22	-102.26	-26.35	2.00	2.00	0.00
<b>Hold 16° Tangent</b>									
5,300.00	16.00	292.91	5,288.91	45.24	-107.05	-27.58	0.00	0.00	0.00
5,400.00	16.00	292.91	5,385.03	55.98	-132.44	-34.12	0.00	0.00	0.00
5,500.00	16.00	292.91	5,481.16	66.71	-157.83	-40.67	0.00	0.00	0.00
5,600.00	16.00	292.91	5,577.28	77.44	-183.23	-47.21	0.00	0.00	0.00
5,700.00	16.00	292.91	5,673.41	88.18	-208.62	-53.75	0.00	0.00	0.00
5,800.00	16.00	292.91	5,769.53	98.91	-234.02	-60.30	0.00	0.00	0.00
5,900.00	16.00	292.91	5,865.66	109.64	-259.41	-66.84	0.00	0.00	0.00
6,000.00	16.00	292.91	5,961.78	120.37	-284.80	-73.38	0.00	0.00	0.00
6,100.00	16.00	292.91	6,057.90	131.11	-310.20	-79.92	0.00	0.00	0.00
6,200.00	16.00	292.91	6,154.03	141.84	-335.59	-86.47	0.00	0.00	0.00
6,300.00	16.00	292.91	6,250.15	152.57	-360.98	-93.01	0.00	0.00	0.00
6,400.00	16.00	292.91	6,346.28	163.31	-386.38	-99.55	0.00	0.00	0.00
6,500.00	16.00	292.91	6,442.40	174.04	-411.77	-106.09	0.00	0.00	0.00
6,600.00	16.00	292.91	6,538.53	184.77	-437.16	-112.64	0.00	0.00	0.00
6,700.00	16.00	292.91	6,634.65	195.50	-462.56	-119.18	0.00	0.00	0.00
6,800.00	16.00	292.91	6,730.78	206.24	-487.95	-125.72	0.00	0.00	0.00
6,900.00	16.00	292.91	6,826.90	216.97	-513.35	-132.27	0.00	0.00	0.00
7,000.00	16.00	292.91	6,923.03	227.70	-538.74	-138.81	0.00	0.00	0.00
7,100.00	16.00	292.91	7,019.15	238.44	-564.13	-145.35	0.00	0.00	0.00
7,200.00	16.00	292.91	7,115.28	249.17	-589.53	-151.89	0.00	0.00	0.00
7,300.00	16.00	292.91	7,211.40	259.90	-614.92	-158.44	0.00	0.00	0.00
7,400.00	16.00	292.91	7,307.53	270.63	-640.31	-164.98	0.00	0.00	0.00
7,500.00	16.00	292.91	7,403.65	281.37	-665.71	-171.52	0.00	0.00	0.00
7,600.00	16.00	292.91	7,499.78	292.10	-691.10	-178.07	0.00	0.00	0.00
7,700.00	16.00	292.91	7,595.90	302.83	-716.50	-184.61	0.00	0.00	0.00
7,800.00	16.00	292.91	7,692.03	313.57	-741.89	-191.15	0.00	0.00	0.00
7,900.00	16.00	292.91	7,788.15	324.30	-767.28	-197.69	0.00	0.00	0.00
8,000.00	16.00	292.91	7,884.27	335.03	-792.68	-204.24	0.00	0.00	0.00
8,100.00	16.00	292.91	7,980.40	345.76	-818.07	-210.78	0.00	0.00	0.00
8,200.00	16.00	292.91	8,076.52	356.50	-843.46	-217.32	0.00	0.00	0.00
8,300.00	16.00	292.91	8,172.65	367.23	-868.86	-223.87	0.00	0.00	0.00
8,400.00	16.00	292.91	8,268.77	377.96	-894.25	-230.41	0.00	0.00	0.00
8,500.00	16.00	292.91	8,364.90	388.70	-919.65	-236.95	0.00	0.00	0.00
8,600.00	16.00	292.91	8,461.02	399.43	-945.04	-243.49	0.00	0.00	0.00
8,700.00	16.00	292.91	8,557.15	410.16	-970.43	-250.04	0.00	0.00	0.00
8,800.00	16.00	292.91	8,653.27	420.90	-995.83	-256.58	0.00	0.00	0.00
8,900.00	16.00	292.91	8,749.40	431.63	-1,021.22	-263.12	0.00	0.00	0.00
9,000.00	16.00	292.91	8,845.52	442.36	-1,046.61	-269.67	0.00	0.00	0.00
9,100.00	16.00	292.91	8,941.65	453.09	-1,072.01	-276.21	0.00	0.00	0.00
9,200.00	16.00	292.91	9,037.77	463.83	-1,097.40	-282.75	0.00	0.00	0.00
9,300.00	16.00	292.91	9,133.90	474.56	-1,122.80	-289.29	0.00	0.00	0.00
9,322.74	16.00	292.91	9,155.76	477.00	-1,128.57	-290.78	0.00	0.00	0.00
<b>KOP, Build &amp; Turn 10°/100'</b>									
9,400.00	14.84	263.88	9,230.34	480.10	-1,148.25	-290.70	10.00	-1.51	-37.58
9,500.00	18.63	231.13	9,326.30	468.68	-1,173.48	-275.40	10.00	3.79	-32.75
9,600.00	25.87	212.62	9,418.90	440.21	-1,197.74	-243.42	10.00	7.24	-18.51
9,700.00	34.45	202.29	9,505.34	395.54	-1,220.28	-195.73	10.00	8.58	-10.33
9,800.00	43.58	195.77	9,582.99	336.05	-1,240.43	-133.78	10.00	9.13	-6.52
9,900.00	52.98	191.16	9,649.48	263.52	-1,257.58	-59.45	10.00	9.39	-4.61
10,000.00	62.51	187.58	9,702.80	180.18	-1,271.19	24.99	10.00	9.53	-3.58
10,100.00	72.12	184.57	9,741.33	88.55	-1,280.86	117.00	10.00	9.61	-3.01
10,200.00	81.77	181.88	9,763.90	-8.59	-1,286.29	213.76	10.00	9.65	-2.69
10,285.13	90.00	179.70	9,770.00	-93.41	-1,287.45	297.68	10.00	9.67	-2.57

## OXY Planning Report

<b>Database:</b>	HOSPSP	<b>Local Co-ordinate Reference:</b>	Well Olive Won Unit 2H
<b>Company:</b>	ENGINEERING DESIGNS	<b>TVD Reference:</b>	RKB=25' @ 3540.00ft
<b>Project:</b>	PRD NM DIRECTIONAL PLANS (NAD 1983)	<b>MD Reference:</b>	RKB=25' @ 3540.00ft
<b>Site:</b>	Olive Won	<b>North Reference:</b>	Grid
<b>Well:</b>	Olive Won Unit 2H	<b>Survey Calculation Method:</b>	Minimum Curvature
<b>Wellbore:</b>	ORIG HOLE		
<b>Design:</b>	Permitting Plan		

Planned Survey									
Measured Depth (ft)	Inclination (°)	Azimuth (°)	Vertical Depth (ft)	+N/-S (ft)	+E/-W (ft)	Vertical Section (ft)	Dogleg Rate (°/100ft)	Build Rate (°/100ft)	Turn Rate (°/100ft)
<b>Landing Point</b>									
10,300.00	90.00	179.70	9,770.00	-108.28	-1,287.37	312.34	0.00	0.00	0.00
10,400.00	90.00	179.70	9,770.00	-208.28	-1,286.84	410.98	0.00	0.00	0.00
10,500.00	90.00	179.70	9,770.00	-308.28	-1,286.31	509.61	0.00	0.00	0.00
10,600.00	90.00	179.70	9,770.00	-408.28	-1,285.78	608.24	0.00	0.00	0.00
10,700.00	90.00	179.70	9,770.00	-508.28	-1,285.25	706.87	0.00	0.00	0.00
10,800.00	90.00	179.70	9,770.00	-608.28	-1,284.72	805.51	0.00	0.00	0.00
10,900.00	90.00	179.70	9,770.00	-708.28	-1,284.19	904.14	0.00	0.00	0.00
11,000.00	90.00	179.70	9,770.00	-808.27	-1,283.66	1,002.77	0.00	0.00	0.00
11,100.00	90.00	179.70	9,770.00	-908.27	-1,283.13	1,101.40	0.00	0.00	0.00
11,200.00	90.00	179.70	9,770.00	-1,008.27	-1,282.60	1,200.04	0.00	0.00	0.00
11,300.00	90.00	179.70	9,770.00	-1,108.27	-1,282.07	1,298.67	0.00	0.00	0.00
11,400.00	90.00	179.70	9,770.00	-1,208.27	-1,281.54	1,397.30	0.00	0.00	0.00
11,500.00	90.00	179.70	9,770.00	-1,308.27	-1,281.01	1,495.93	0.00	0.00	0.00
11,600.00	90.00	179.70	9,770.00	-1,408.27	-1,280.48	1,594.57	0.00	0.00	0.00
11,700.00	90.00	179.70	9,770.00	-1,508.27	-1,279.95	1,693.20	0.00	0.00	0.00
11,800.00	90.00	179.70	9,770.00	-1,608.26	-1,279.42	1,791.83	0.00	0.00	0.00
11,900.00	90.00	179.70	9,770.00	-1,708.26	-1,278.89	1,890.46	0.00	0.00	0.00
12,000.00	90.00	179.70	9,770.00	-1,808.26	-1,278.36	1,989.10	0.00	0.00	0.00
12,100.00	90.00	179.70	9,770.00	-1,908.26	-1,277.83	2,087.73	0.00	0.00	0.00
12,200.00	90.00	179.70	9,770.00	-2,008.26	-1,277.30	2,186.36	0.00	0.00	0.00
12,300.00	90.00	179.70	9,770.00	-2,108.26	-1,276.77	2,284.99	0.00	0.00	0.00
12,400.00	90.00	179.70	9,770.00	-2,208.26	-1,276.24	2,383.62	0.00	0.00	0.00
12,500.00	90.00	179.70	9,770.00	-2,308.25	-1,275.71	2,482.26	0.00	0.00	0.00
12,600.00	90.00	179.70	9,770.00	-2,408.25	-1,275.18	2,580.89	0.00	0.00	0.00
12,647.75	90.00	179.70	9,770.00	-2,456.00	-1,274.92	2,627.99	0.00	0.00	0.00
<b>PPP-1 Cross</b>									
12,700.00	90.00	179.70	9,770.00	-2,508.25	-1,274.65	2,679.52	0.00	0.00	0.00
12,800.00	90.00	179.70	9,770.00	-2,608.25	-1,274.12	2,778.15	0.00	0.00	0.00
12,900.00	90.00	179.70	9,770.00	-2,708.25	-1,273.59	2,876.79	0.00	0.00	0.00
13,000.00	90.00	179.70	9,770.00	-2,808.25	-1,273.06	2,975.42	0.00	0.00	0.00
13,100.00	90.00	179.70	9,770.00	-2,908.25	-1,272.53	3,074.05	0.00	0.00	0.00
13,200.00	90.00	179.70	9,770.00	-3,008.24	-1,272.00	3,172.68	0.00	0.00	0.00
13,300.00	90.00	179.70	9,770.00	-3,108.24	-1,271.47	3,271.32	0.00	0.00	0.00
13,400.00	90.00	179.70	9,770.00	-3,208.24	-1,270.94	3,369.95	0.00	0.00	0.00
13,500.00	90.00	179.70	9,770.00	-3,308.24	-1,270.40	3,468.58	0.00	0.00	0.00
13,600.00	90.00	179.70	9,770.00	-3,408.24	-1,269.87	3,567.21	0.00	0.00	0.00
13,700.00	90.00	179.70	9,770.00	-3,508.24	-1,269.34	3,665.85	0.00	0.00	0.00
13,800.00	90.00	179.70	9,770.00	-3,608.24	-1,268.81	3,764.48	0.00	0.00	0.00
13,900.00	90.00	179.70	9,770.00	-3,708.23	-1,268.28	3,863.11	0.00	0.00	0.00
14,000.00	90.00	179.70	9,770.00	-3,808.23	-1,267.75	3,961.74	0.00	0.00	0.00
14,100.00	90.00	179.70	9,770.00	-3,908.23	-1,267.22	4,060.38	0.00	0.00	0.00
14,200.00	90.00	179.70	9,770.00	-4,008.23	-1,266.69	4,159.01	0.00	0.00	0.00
14,300.00	90.00	179.70	9,770.00	-4,108.23	-1,266.16	4,257.64	0.00	0.00	0.00
14,400.00	90.00	179.70	9,770.00	-4,208.23	-1,265.63	4,356.27	0.00	0.00	0.00
14,500.00	90.00	179.70	9,770.00	-4,308.23	-1,265.10	4,454.91	0.00	0.00	0.00
14,600.00	90.00	179.70	9,770.00	-4,408.22	-1,264.57	4,553.54	0.00	0.00	0.00
14,700.00	90.00	179.70	9,770.00	-4,508.22	-1,264.04	4,652.17	0.00	0.00	0.00
14,800.00	90.00	179.70	9,770.00	-4,608.22	-1,263.51	4,750.80	0.00	0.00	0.00
14,900.00	90.00	179.70	9,770.00	-4,708.22	-1,262.98	4,849.43	0.00	0.00	0.00
15,000.00	90.00	179.70	9,770.00	-4,808.22	-1,262.45	4,948.07	0.00	0.00	0.00
15,100.00	90.00	179.70	9,770.00	-4,908.22	-1,261.92	5,046.70	0.00	0.00	0.00
15,200.00	90.00	179.70	9,770.00	-5,008.22	-1,261.39	5,145.33	0.00	0.00	0.00
15,300.00	90.00	179.70	9,770.00	-5,108.21	-1,260.86	5,243.96	0.00	0.00	0.00
15,400.00	90.00	179.70	9,770.00	-5,208.21	-1,260.33	5,342.60	0.00	0.00	0.00

## OXY Planning Report

<b>Database:</b>	HOPSPP	<b>Local Co-ordinate Reference:</b>	Well Olive Won Unit 2H
<b>Company:</b>	ENGINEERING DESIGNS	<b>TVD Reference:</b>	RKB=25' @ 3540.00ft
<b>Project:</b>	PRD NM DIRECTIONAL PLANS (NAD 1983)	<b>MD Reference:</b>	RKB=25' @ 3540.00ft
<b>Site:</b>	Olive Won	<b>North Reference:</b>	Grid
<b>Well:</b>	Olive Won Unit 2H	<b>Survey Calculation Method:</b>	Minimum Curvature
<b>Wellbore:</b>	ORIG HOLE		
<b>Design:</b>	Permitting Plan		

Planned Survey										
Measured Depth (ft)	Inclination (°)	Azimuth (°)	Vertical Depth (ft)	+N/-S (ft)	+E/-W (ft)	Vertical Section (ft)	Dogleg Rate (°/100ft)	Build Rate (°/100ft)	Turn Rate (°/100ft)	
15,500.00	90.00	179.70	9,770.00	-5,308.21	-1,259.80	5,441.23	0.00	0.00	0.00	
15,600.00	90.00	179.70	9,770.00	-5,408.21	-1,259.27	5,539.86	0.00	0.00	0.00	
15,700.00	90.00	179.70	9,770.00	-5,508.21	-1,258.74	5,638.49	0.00	0.00	0.00	
15,800.00	90.00	179.70	9,770.00	-5,608.21	-1,258.21	5,737.13	0.00	0.00	0.00	
15,900.00	90.00	179.70	9,770.00	-5,708.21	-1,257.68	5,835.76	0.00	0.00	0.00	
16,000.00	90.00	179.70	9,770.00	-5,808.20	-1,257.15	5,934.39	0.00	0.00	0.00	
16,100.00	90.00	179.70	9,770.00	-5,908.20	-1,256.62	6,033.02	0.00	0.00	0.00	
16,200.00	90.00	179.70	9,770.00	-6,008.20	-1,256.09	6,131.66	0.00	0.00	0.00	
16,300.00	90.00	179.70	9,770.00	-6,108.20	-1,255.56	6,230.29	0.00	0.00	0.00	
16,400.00	90.00	179.70	9,770.00	-6,208.20	-1,255.03	6,328.92	0.00	0.00	0.00	
16,500.00	90.00	179.70	9,770.00	-6,308.20	-1,254.50	6,427.55	0.00	0.00	0.00	
16,600.00	90.00	179.70	9,770.00	-6,408.20	-1,253.97	6,526.19	0.00	0.00	0.00	
16,700.00	90.00	179.70	9,770.00	-6,508.19	-1,253.44	6,624.82	0.00	0.00	0.00	
16,800.00	90.00	179.70	9,770.00	-6,608.19	-1,252.91	6,723.45	0.00	0.00	0.00	
16,900.00	90.00	179.70	9,770.00	-6,708.19	-1,252.38	6,822.08	0.00	0.00	0.00	
17,000.00	90.00	179.70	9,770.00	-6,808.19	-1,251.85	6,920.71	0.00	0.00	0.00	
17,100.00	90.00	179.70	9,770.00	-6,908.19	-1,251.32	7,019.35	0.00	0.00	0.00	
17,200.00	90.00	179.70	9,770.00	-7,008.19	-1,250.79	7,117.98	0.00	0.00	0.00	
17,300.00	90.00	179.70	9,770.00	-7,108.19	-1,250.26	7,216.61	0.00	0.00	0.00	
17,400.00	90.00	179.70	9,770.00	-7,208.19	-1,249.73	7,315.24	0.00	0.00	0.00	
17,500.00	90.00	179.70	9,770.00	-7,308.18	-1,249.20	7,413.88	0.00	0.00	0.00	
17,600.00	90.00	179.70	9,770.00	-7,408.18	-1,248.67	7,512.51	0.00	0.00	0.00	
17,700.00	90.00	179.70	9,770.00	-7,508.18	-1,248.14	7,611.14	0.00	0.00	0.00	
17,800.00	90.00	179.70	9,770.00	-7,608.18	-1,247.61	7,709.77	0.00	0.00	0.00	
17,900.00	90.00	179.70	9,770.00	-7,708.18	-1,247.08	7,808.41	0.00	0.00	0.00	
17,905.13	90.00	179.70	9,770.00	-7,713.31	-1,247.05	7,813.47	0.00	0.00	0.00	
<b>TD at 17905.13' MD</b>										

Design Targets										
Target Name	Dip Angle (°)	Dip Dir. (°)	TVD (ft)	+N/-S (ft)	+E/-W (ft)	Northing (usft)	Easting (usft)	Latitude	Longitude	
KOP (Olive Won Unit - plan misses target center by 1377.69ft at 0.00ft MD (0.00 TVD, 0.00 N, 0.00 E) - Point	0.00	0.00	0.00	482.86	-1,290.30	496,394.17	720,968.57	32.363316	-103.751555	
FTP (Olive Won Unit - plan misses target center by 26.38ft at 10113.02ft MD (9745.19 TVD, 76.15 N, -1281.81 E) - Point	0.00	0.00	9,770.00	82.25	-1,288.38	495,993.59	720,970.49	32.362215	-103.751556	
PBHL (Olive Won Unit - plan hits target center - Point	0.00	0.00	9,770.00	-7,713.31	-1,247.05	488,198.46	721,011.82	32.340788	-103.751559	

**OXY**  
Planning Report

<b>Database:</b>	HOPSPP	<b>Local Co-ordinate Reference:</b>	Well Olive Won Unit 2H
<b>Company:</b>	ENGINEERING DESIGNS	<b>TVD Reference:</b>	RKB=25' @ 3540.00ft
<b>Project:</b>	PRD NM DIRECTIONAL PLANS (NAD 1983)	<b>MD Reference:</b>	RKB=25' @ 3540.00ft
<b>Site:</b>	Olive Won	<b>North Reference:</b>	Grid
<b>Well:</b>	Olive Won Unit 2H	<b>Survey Calculation Method:</b>	Minimum Curvature
<b>Wellbore:</b>	ORIG HOLE		
<b>Design:</b>	Permitting Plan		

Formations						
Measured Depth (ft)	Vertical Depth (ft)	Name	Lithology	Dip (°)	Dip Direction (°)	
843.00	843.00	RUSTLER				
1,132.00	1,132.00	SALADO				
2,000.00	2,000.00	MARKER BED 126				
3,024.00	3,024.00	CASTILE				
4,429.00	4,429.00	DELAWARE				
4,480.00	4,480.00	BELL CANYON				
5,429.10	5,413.00	CHERRY CANYON				
6,603.61	6,542.00	BRUSHY CANYON				
8,447.05	8,314.00	BONE SPRING				
9,646.47	9,460.00	BONE SPRING 1ST				

Plan Annotations					
Measured Depth (ft)	Vertical Depth (ft)	Local Coordinates		Comment	
		+N/-S (ft)	+E/-W (ft)		
4,481.00	4,481.00	0.00	0.00	Build 2°/100'	
5,281.15	5,270.79	43.22	-102.26	Hold 16° Tangent	
9,322.74	9,155.76	477.00	-1,128.57	KOP, Build & Turn 10°/100'	
10,285.13	9,770.00	-93.41	-1,287.45	Landing Point	
12,647.75	9,770.00	-2,456.00	-1,274.92	PPP-1 Cross	
17,905.13	9,770.00	-7,713.31	-1,247.05	TD at 17905.13' MD	

# Oxy USA Inc. - OLIVE WON UNIT 2H Drill Plan

## 1. Geologic Formations

TVD of Target (ft):	9770	Pilot Hole Depth (ft):	
Total Measured Depth (ft):	17905	Deepest Expected Fresh Water (ft):	843

### Delaware Basin

Formation	MD-RKB (ft)	TVD-RKB (ft)	Expected Fluids
Rustler	843	843	
Salado	1132	1132	Salt
Marker Bed 126	2000	2000	Salt
Castile	3024	3024	Salt
Delaware	4429	4429	Oil/Gas/Brine
Bell Canyon	4480	4480	Oil/Gas/Brine
Cherry Canyon	5429	5413	Oil/Gas/Brine
Brushy Canyon	6604	6542	Losses
Bone Spring	8447	8314	Oil/Gas
Bone Spring 1st	9646	9460	Oil/Gas
Bone Spring 2nd			Oil/Gas
Bone Spring 3rd			Oil/Gas
Wolfcamp			Oil/Gas
Penn			Oil/Gas
Strawn			Oil/Gas

\*H2S, water flows, loss of circulation, abnormal pressures, etc.

## 2. Casing Program

Section	Hole Size (in)	MD		TVD		Csg. OD (in)	Csg Wt. (ppf)	Grade	Conn.
		From (ft)	To (ft)	From (ft)	To (ft)				
Surface	17.5	0	913	0	913	13.375	54.5	J-55	BTC
Intermediate	9.875	0	9223	0	9223	7.625	26.4	L-80 HC	BTC
Production	6.75	0	17905	0	9770	5.5	20	P-110	DWC/C-HT-IS

All casing strings will be tested in accordance with 43 CFR part 3170 Subpart 3172

\*Oxy requests the option to run the 10.75" Intermediate I as a contingency string to be run only if severe hole conditions dictate an additional casing string necessary. This would make the planned 7.625" / 7.827" Casing the Intermediate II.  
 \*\*If 4S Contingency is not required, Oxy requests permission to transition from 12.25" to 9.875" Intermediate I at 1st trip point below Brushy top (estimated top in formation table above). Cement volumes will be updated on C103 submission.

<i>All Casing SF Values will meet or exceed those below</i>			
<b>SF Collapse</b>	<b>SF Burst</b>	<b>Body SF Tension</b>	<b>Joint SF Tension</b>
1.00	1.100	1.4	1.4

**Annular Clearance Variance Request**

As per the agreement reached in the Oxy/BLM face-to-face meeting on Feb 22, 2018, Oxy requests permission to allow deviation from the 0.422" annular clearance requirement. Please see Annular Clearance Variance attachment for further details.

	Y or N
Is casing new? If used, attach certification as required in 43 CFR 3160	Y
Does casing meet API specifications? If no, attach casing specification sheet.	Y
Is premium or uncommon casing planned? If yes attach casing specification sheet.	Y
Does the above casing design meet or exceed BLM's minimum standards? If not provide justification (loading assumptions, casing design criteria).	Y
Will the intermediate pipe be kept at a minimum 1/3 fluid filled to avoid approaching the collapse pressure rating of the casing?	Y
<b>Is well located within Capitan Reef?</b>	
If yes, does production casing cement tie back a minimum of 50' above the Reef?	N
Is well within the designated 4 string boundary.	
<b>Is well located in SOPA but not in R-111-Q?</b>	
If yes, are the first 2 strings cemented to surface and 3 <sup>rd</sup> string cement tied back 500' into previous casing?	Y
<b>Is well located in R-111-Q and SOPA?</b>	
If yes, are the first three strings cemented to surface?	N
Is 2 <sup>nd</sup> string set 100' to 600' below the base of salt?	
<b>Is well located in high Cave/Karst?</b>	
If yes, are there two strings cemented to surface?	N
(For 2 string wells) If yes, is there a contingency casing if lost circulation occurs?	
<b>Is well located in critical Cave/Karst?</b>	
If yes, are there three strings cemented to surface?	N

### 3. Cementing Program

Section	Stage	Slurry:	Sacks	Yield (ft <sup>3</sup> /ft)	Density (lb/gal)	Excess:	TOC	Placement	Description
Surface	1	Surface - Tail	954	1.33	14.8	100%	-	Circulate	Class C+Accel.
Int.	1	Intermediate 1S - Tail	318	1.68	13.2	5%	6,854	Circulate	Class C+Ret., Disper.
Int.	2	Intermediate 2S - Tail BH	1227	1.71	13.3	25%	-	Bradenhead	Class C+Accel.
Prod.	1	Production - Tail	520	1.84	13.3	25%	8,723	Circulate	Class C+Ret.

#### Offline Cementing Request

Oxy requests a variance to cement the 9.625" and/or 7.625" intermediate casing strings offline in accordance to the approved variance, EC Tran 461365. Please see Offline Cementing Variance attachment for further details.

#### Bradenhead CBL Request

Oxy requests permission to adjust the CBL requirement after bradenhead cement jobs, on 7-5/8" intermediate casings, as per the agreement reached in the OXY/BLM meeting on September 5, 2019. Please see Bradenhead CBL Variance attachment for further details.

**4. Pressure Control Equipment**

BOP installed and tested before drilling which hole?	Size?	Min. Required WP	Type	✓	Tested to:	Deepest TVD Depth (ft) per Section:
9.875" Hole	13-5/8"	5M	Annular	✓	70% of working pressure	9223
		5M	Blind Ram	✓	250 psi / 5000 psi	
			Pipe Ram			
			Double Ram	✓		
			Other*			
6.75" Hole	13-5/8"	5M	Annular	✓	70% of working pressure	9770
		5M	Blind Ram	✓	250 psi / 5000 psi	
			Pipe Ram			
			Double Ram	✓		
			Other*			

\*Specify if additional ram is utilized

BOP/BOPE will be tested by an independent service company to 250 psi low and the high pressure indicated above per 43 CFR part 3170 Subpart 3172 requirements. The System may be upgraded to a higher pressure but still tested to the working pressure listed in the table above. If the system is upgraded all the components installed will be functional and tested.

Pipe rams will be operationally checked each 24 hour period. Blind rams will be operationally checked on each trip out of the hole. These checks will be noted on the daily tour sheets. Other accessories to the BOP equipment will include a Kelly cock and floor safety valve (inside BOP) and choke lines and choke manifold.

	<p>Formation integrity test will be performed per 43 CFR part 3170 Subpart 3172. On Exploratory wells or on that portion of any well approved for a 5M BOPE system or greater, a pressure integrity test of each casing shoe shall be performed. Will be tested in accordance with 43 CFR part 3170 Subpart 3172.</p>
	<p>A variance is requested for the use of a flexible choke line from the BOP to Choke Manifold. See attached for specs and hydrostatic test chart.</p>
Y	<p>Are anchors required by manufacturer?</p>
	<p>A multibowl or a unionized multibowl wellhead system will be employed. The wellhead and connection to the BOPE will meet all API 6A requirements. The BOP will be tested per 43 CFR part 3170 Subpart 3172 after installation on the surface casing which will cover testing requirements for a maximum of 30 days. If any seal subject to test pressure is broken the system must be tested. We will test the flange connection of the wellhead with a test port that is directly in the flange. We are proposing that we will run the wellhead through the rotary prior to cementing surface casing as discussed with the BLM on October 8, 2015.</p> <p>See attached schematics.</p>

**BOP Break Testing Request**

Oxy requests permission to adjust the BOP break testing (intermediate and production) requirements as per the agreement reached in the OXY/BLM meeting on April 4th, 2025. Please see BOP Break Testing Variance attachment for further details.

**Oxy will use Cameron ADAPT wellhead system that uses an OEC top flange connection. This connection has been fully vetted and verified by API to Spec 6A and carries an API monogram.**

**5. Mud Program**

Section	Depth - MD		Depth - TVD		Type	Weight (ppg)	Viscosity	Water Loss
	From (ft)	To (ft)	From (ft)	To (ft)				
Surface	0	913	0	913	Water-Based Mud	8.6 - 8.8	40-60	N/C
Intermediate	913	9223	913	9223	Saturated Brine-Based or Oil-Based Mud	8.0 - 10.0	35-45	N/C
Production	9223	17905	9223	9770	Water-Based or Oil-Based Mud	8.0 - 8.5	38-50	N/C

Sufficient mud materials to maintain mud properties and meet minimum lost circulation and weight increase requirements will be kept on location at all times. The following is a general list of products: Barite, Bentonite, Gypsum, Lime, Soda Ash, Caustic Soda, Nut Plug, Cedar Fiber, Cotton Seed Hulls, Drilling Paper, Salt Water Clay, ACL2. Oxy will use a closed mud system.

What will be used to monitor the loss or gain of fluid?	PVT/MD Totco/Visual Monitoring
---	--------------------------------

**6. Logging and Testing Procedures**

<b>Logging, Coring and Testing.</b>	
Yes	Will run GR from TD to surface (horizontal well – vertical portion of hole). Stated logs run will be in the Completion Report and submitted to the BLM.
No	Logs are planned based on well control or offset log information.
No	Drill stem test? If yes, explain
No	Coring? If yes, explain
<b>Additional logs planned</b>	<b>Interval</b>
No	Resistivity
No	Density
Yes	CBL Production string
Yes	Mud log Bone Spring – TD
No	PEX

**7. Drilling Conditions**

Condition	Specify what type and where?
BH Pressure at deepest TVD	4319 psi
Abnormal Temperature	No
BH Temperature at deepest TVD	159°F

Pump high viscosity sweeps as needed for hole cleaning. The mud system will be monitored visually/manually as well as with an electronic PVT. The necessary mud products for additional weight and fluid loss control will be on location at all times. Appropriately weighted mud will be used to isolate potential gas, oil, and water zones until such time as casing can be cemented into place for zonal

Hydrogen Sulfide (H2S) monitors will be installed prior to drilling out the surface shoe. If H2S is detected in concentrations greater than 100 ppm, the operator will comply with the provisions of 43 CFR part 3170 Subpart 3172. If Hydrogen Sulfide is encountered, measured values and formations will be provided to the BLM.	
N	H2S is present
Y	H2S Plan attached

**8. Other facets of operation**

	Yes/No
Will the well be drilled with a walking/skidding operation? If yes, describe. We plan to drill the 6 well pad in batch by section: all surface sections, intermediate sections and production sections. The wellhead will be secured with a night cap whenever the rig is not over the well.	Yes
Will more than one drilling rig be used for drilling operations? If yes, describe. Oxy requests the option to contract a Surface Rig to drill, set surface casing, and cement for this well. If the timing between rigs is such that Oxy would not be able to preset surface, the Primary Rig will MIRU and drill the well in its entirety per the APD. Please see the attached document for information on the spudder rig.	Yes

**Total Estimated Cuttings Volume: 1444 bbls**

<p><b>C-102</b></p> <p>Submit Electronically Via OCD Permitting</p>	<p>State of New Mexico <b>Energy, Minerals, &amp; Natural Resources Department</b> <b>OIL CONSERVATION DIVISION</b></p>	<p>Revised July 9, 2024 PAGE 1 OF 2</p>		
		<table border="1" style="width:100%; border-collapse: collapse;"> <tr> <td style="width:10%; border: none;">Submittal Type:</td> <td style="border: none;"> <input type="checkbox"/> Initial Submittal  <input checked="" type="checkbox"/> Amended Report  <input type="checkbox"/> As Drilled                 </td> </tr> </table>	Submittal Type:	<input type="checkbox"/> Initial Submittal <input checked="" type="checkbox"/> Amended Report <input type="checkbox"/> As Drilled
Submittal Type:	<input type="checkbox"/> Initial Submittal <input checked="" type="checkbox"/> Amended Report <input type="checkbox"/> As Drilled			

**WELL LOCATION INFORMATION**

API Number <b>30-015-55176</b>	Pool Code <b>39350</b>	Pool Name <b>LIVINGSTON RIDGE;BONE SPRING</b>
Property Code <b>335973</b>	Property Name <b>OLIVE WON UNIT</b>	Well Number <b>2H</b>
OGRID No. <b>16696</b>	Operator Name <b>OXY USA INC.</b>	Ground Level Elevation <b>3515'</b>
Surface Owner: <input type="checkbox"/> State <input type="checkbox"/> Fee <input type="checkbox"/> Tribal <input checked="" type="checkbox"/> Federal		Mineral Owner: <input type="checkbox"/> State <input type="checkbox"/> Fee <input type="checkbox"/> Tribal <input checked="" type="checkbox"/> Federal

**Surface Location**

UL	Section	Township	Range	Lot	Ft. from N/S	Ft. from E/W	Latitude (NAD83)	Longitude (NAD83)	County
J	26	22S	31E		2449' FSL	2261' FEL	32.36196922	-103.74738450	EDDY

**Bottom Hole Location**

UL	Section	Township	Range	Lot	Ft. from N/S	Ft. from E/W	Latitude (NAD83)	Longitude (NAD83)	County
N	35	22S	31E		20' FSL	1730' FWL	32.34078746	-103.75155863	EDDY

Dedicated Acres <b>960.00</b>	Infill or Defining Well <b>INFILL</b>	Defining Well API <b>71H - 30-015-55183</b>	Overlapping Spacing Unit (Y/N) <b>N</b>	Consolidation Code <b>U</b>
Order Numbers: <b>R-23133</b>			Well setbacks are under Common Ownership: <input type="checkbox"/> Yes <input checked="" type="checkbox"/> No	

**Kick Off Point (KOP)**

UL	Section	Township	Range	Lot	Ft. from N/S	Ft. from E/W	Latitude (NAD83)	Longitude (NAD83)	County
F	26	22S	31E		2339' FNL	1730' FWL	32.36331573	-103.75155447	EDDY

**First Take Point (FTP)**

UL	Section	Township	Range	Lot	Ft. from N/S	Ft. from E/W	Latitude (NAD83)	Longitude (NAD83)	County
K	26	22S	31E		2538' FSL	1730' FWL	32.36221462	-103.75155531	EDDY

**Last Take Point (LTP)**

UL	Section	Township	Range	Lot	Ft. from N/S	Ft. from E/W	Latitude (NAD83)	Longitude (NAD83)	County
N	35	22S	31E		100' FSL	1730' FWL	32.34100736	-103.75155855	EDDY

Unitized Area or Area of Uniform Interest <b>Y</b>	Spacing Unit Type: <input checked="" type="checkbox"/> Horizontal <input type="checkbox"/> Vertical	Ground Floor Elevation <b>3515'</b>
---	---	--

<p><b>OPERATOR CERTIFICATIONS</b></p> <p><i>I hereby certify that the information contained herein is true and complete to the best of my knowledge and belief, and, if the well is a vertical or directional well, that this organization either owns a working interest or unleased mineral interest in the land including the proposed bottom hole location or has a right to drill this well at this location pursuant to a contract with an owner of a working interest or unleased mineral interest, or to a voluntary pooling agreement or a compulsory pooling order heretofore entered by the division.</i></p> <p><i>If this well is a horizontal well, I further certify that this organization has received the consent of at least one lessee or owner of a working interest or unleased mineral interest in each tract (in the target pool or formation) in which any part of the well's completed interval will be located or obtained a compulsory pooling order from the division.</i></p> <p><b>Melissa Guidry</b> 02/04/26 Signature Date</p> <p><b>Melissa Guidry</b> Printed Name</p> <p><b>melissa_guidry@oxy.com</b> Email Address</p>	<p><b>SURVEYOR CERTIFICATIONS</b></p> <p><i>I hereby certify that the well location shown on this plat was plotted from field notes of actual surveys made by me or under my supervision, and that the same is true and correct to the best of my belief.</i></p> <div style="text-align: center;">  </div> <p>Signature and Seal of Professional Surveyor</p> <table style="width:100%;"> <tr> <td style="width:50%;">Certificate Number <b>21653</b></td> <td style="width:50%;">Date of Survey <b>DECEMBER 18, 2025</b></td> </tr> </table>	Certificate Number <b>21653</b>	Date of Survey <b>DECEMBER 18, 2025</b>
Certificate Number <b>21653</b>	Date of Survey <b>DECEMBER 18, 2025</b>		

Note: No allowable will be assigned to this completion until all interests have been consolidated or a non-standard unit has been approved by the division.

OLIVE WON UNIT 2H

ACREAGE DEDICATION PLATS

**SHL (NAD83)**  
 X:722258.80' / Y:495911.34'  
 LAT:32.36196922 / LON:-103.74738450

**SHL (NAD27)**  
 X:681076.23' / Y:495851.14'  
 LAT:32.36184654 / LON:-103.74689617

**KOP (NAD83)**  
 X:720968.57' / Y:496394.17'  
 LAT:32.36331573 / LON:-103.75155447

**KOP (NAD27)**  
 X:679786.02' / Y:496333.96'  
 LAT:32.36319307 / LON:-103.75106598

**FTP (NAD83)**  
 X:720970.49' / Y:495993.59'  
 LAT:32.36221462 / LON:-103.75155531

**FTP (NAD27)**  
 X:679787.92' / Y:495933.39'  
 LAT:32.36209196 / LON:-103.75106686

**PPP-1 (NAD83)**  
 X:720983.95' / Y:493455.63'  
 LAT:32.35523831 / LON:-103.75155639

**PPP-1 (NAD27)**  
 X:679801.31' / Y:493395.50'  
 LAT:32.35511561 / LON:-103.75106822

**LTP (NAD83)**  
 X:721011.41' / Y:488278.46'  
 LAT:32.34100736 / LON:-103.75155855

**LTP (NAD27)**  
 X:679828.62' / Y:488218.47'  
 LAT:32.34088459 / LON:-103.75107095

**BHL (NAD83)**  
 X:721011.82' / Y:488198.46'  
 LAT:32.34078746 / LON:-103.75155863

**BHL (NAD27)**  
 X:679829.02' / Y:488138.47'  
 LAT:32.34066468 / LON:-103.75107105

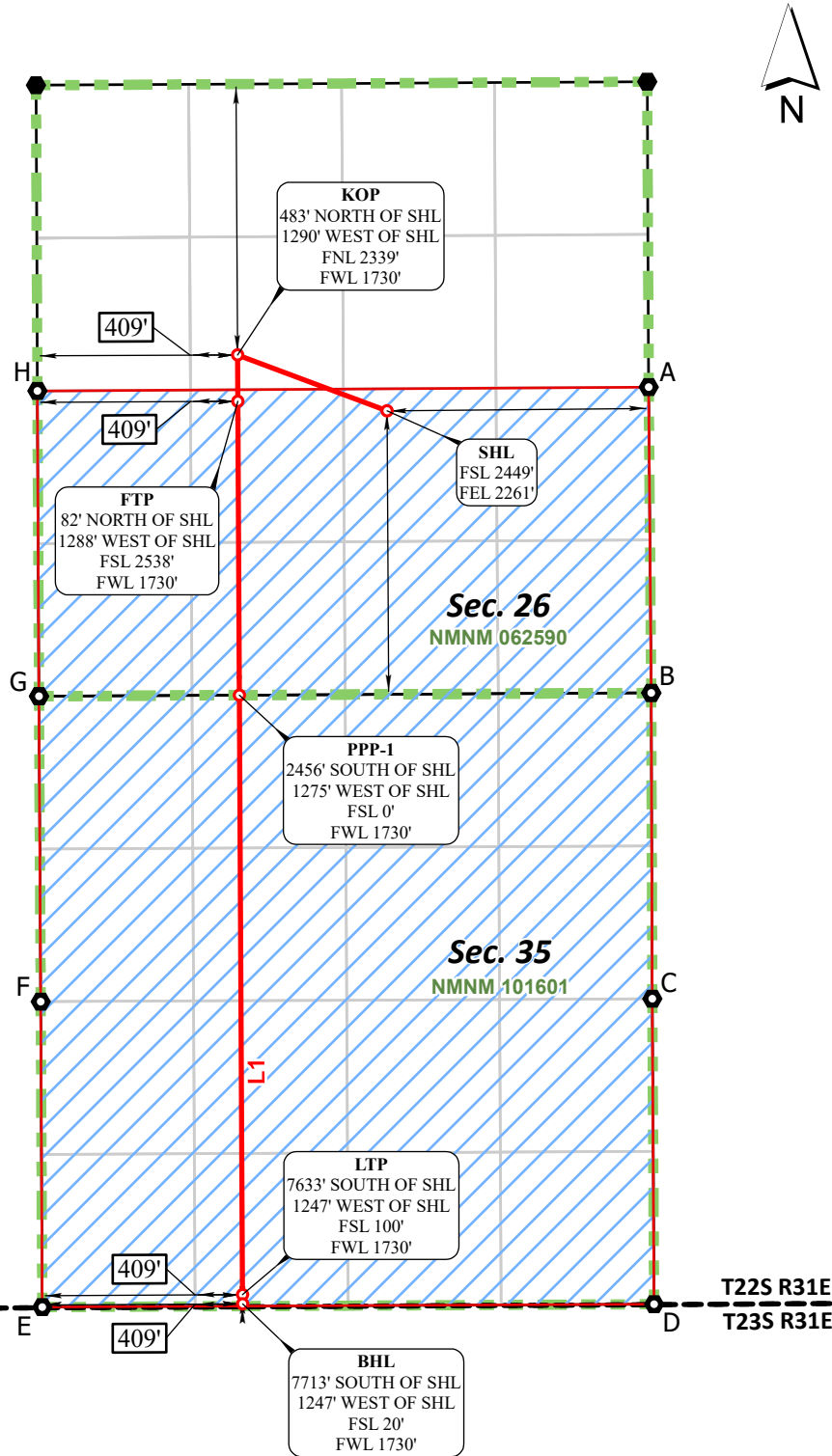

CORNER COORDINATES NAD 83, SPCS NM EAST		CORNER COORDINATES NAD 27, SPCS NM EAST	
A - X: 724517.84' / Y:496116.14'	B - X: 724539.94' / Y:493474.89'	A - X: 683335.26' / Y:496055.94'	B - X: 683357.28' / Y:493414.76'
C - X: 724548.88' / Y:490833.64'	D - X: 724564.45' / Y:488195.28'	C - X: 683366.15' / Y:490773.58'	D - X: 683381.64' / Y:488135.29'
E - X: 719281.94' / Y:488170.27'	F - X: 719268.50' / Y:490808.20'	E - X: 678099.14' / Y:488110.28'	F - X: 678085.78' / Y:490748.14'
G - X: 719253.73' / Y:493446.25'	H - X: 719240.01' / Y:496083.00'	G - X: 678071.09' / Y:493386.12'	H - X: 678057.45' / Y:496022.80'

\*FTP TO LTP LINE BEARINGS

LINE	BEARING
L1	S 00°18'14" E ~ 7715.24'

\*FTP TO LTP LEASE DISTANCES

TRACT	DISTANCE
NMNM 062590	2538.00'
NMNM 101601	5177.24'
TOTAL	7715.24'



○ Drill Line Events    ● Section Corners    — Drill Line    ← Dimension Lines    □ Federal Leases    □ HSU    ○ HSU Corners

All bearings and coordinates refer to New Mexico State Plane Coordinate System, East Zone, U.S. Survey Feet.

JOB No. 20251068\_16432  
 REV 2 ANC 12/17/2025

Distances/areas relative to NAD 83 grid measurements. Combined Scale Factor: 0.99978405 and a Convergence Angle: 0.33175944°

OXY APD CHANGE SUNDRY LIST FORM

DATE SUNDRY WORKSHEET CREATED	2/18/2026
WELL NAME - NUMBER	EVIL OLIVE 26_35 FEDERAL COM 2H
API NUMBER	30-015-55176
ESTIMATED SPUD DATE	

ITEM		APD BASE LINE (For Regulatory to Complete)								SUNDRY PLAN (Groups to complete the latest plan)																							
Surface Planning	NAME	Date APD/BASE LINE APPROVED: 05/23/24								DATE Sundry Worksheet : 02/18/26																							
	NSL	EVIL OLIVE 26_35 FEDERAL COM 2H								OLIVE WON UNIT 2H																							
	SHL	NO								NO																							
	PAD	2614' FSL 1763' FWL								2440 FSL 2261' FEL																							
	BHL	LSTTNK_22531E_26_1								LSTTNK_22531E_26_2																							
	HSU SIZE, ACRES	20' FSL 1740' FWL								20' FSL 1730' FWL																							
	POOL	240								960																							
TVD	LIVINGSTON RIDGE								LIVINGSTON RIDGE																								
TARGET FORMATION	9851								9770																								
		BONE SPRING								BONE SPRING																							
Drilling	CASING PROGRAM	APD BASE LINE																SUNDRY PLAN															
		Section	Hole Size (in.)	MD	TVD	Csg OD (in)	Csg WT	Grade	Conn.	Section	Hole Size (in.)	MD	TVD	Csg OD (in)	Csg WT (ppf)	Grade	Conn.																
		Surface	17.5	897	897	13.375	54.5	J-55	BTC	Surface	17.5	913	913	13.375	54.5	J-55	BTC																
		Int	12.25	9120	9079	7.625	29.7	L-80 HC	BTC	Int	9.875	9223	9223	7.625	26.4	L-80 HC	BTC																
		Int2								Int2																							
	Prod	6.75	18016	9851	5.5	20	P-110	WEDGE 461	Prod	6.75	17905	9770	5.5	20	P-110	DWC/C-HT-IS																	
	Liner								Liner																								
	CEMENT PROGRAM	APD BASE LINE																SUNDRY PLAN															
		Section/Stage	Slurry	Sacks	Yield (ft <sup>3</sup> /ft)	Density (lb/gal)	Excess	TOC	Placement	Description	Section/Stage	Slurry	Sacks	Yield (ft <sup>3</sup> /ft)	Density (lb/gal)	Excess	TOC	Placement	Description														
		Surf	SURFACE - TAIL	937	1.33	14.8	100%		CIRCULATE	CLASS C-ACCEL	Surf	SURFACE - TAIL	954	1.33	14.8	100%		CIRCULATE	CLASS C-ACCEL														
Int/1		INTERMEDIATE 15 - TAIL	741	1.65	13.2	5%	6797	CIRCULATE	CLASS HAACCEL DISP, SALT	Int	INTERMEDIATE 15 - TAIL	318	1.68	13.2	5%	6854	CIRCULATE	CLASS C-RET., Disper															
Int/2		INTERMEDIATE 25 - TAIL BH	2451	1.71	13.3	25%		BRADENHEAD	CLASS C-ACCEL	Int	INTERMEDIATE 25 - TAIL BH	1227	1.71	13.3	25%		BRADENHEAD	CLASS C-ACCEL															
Int2									Int2																								
Prod	PRODUCTION - TAIL	707	1.38	13.2	25%	8620	CIRCULATE	CLASS H-RET, DISP, SALT	Prod	PRODUCTION - TAIL	520	1.94	13.3	25%	8723	CIRCULATE	CLASS C-RET																
VARIANCES	APD BASE LINE																SUNDRY PLAN																
	BOP Break Testing Variance		X							BOP Break Testing Variance		X																					
	SM Annular BOP Variance									SM Annular BOP Variance																							
	Bradenhead CBL Variance		X							Bradenhead CBL Variance		X																					
	Offline Cementing Variance		X							Offline Cementing Variance		X																					
	Production Annular Clearance Variance		X							Production Annular Clearance Variance		X																					
Flexible Choke Line Variance									Flexible Choke Line Variance																								
(Pilot Hole, Logs etc.)									(Pilot Hole, Logs etc.)																								

Sante Fe Main Office  
Phone: (505) 476-3441

General Information  
Phone: (505) 629-6116

Online Phone Directory  
<https://www.emnrd.nm.gov/ocd/contact-us>

**State of New Mexico**  
**Energy, Minerals and Natural Resources**  
**Oil Conservation Division**  
**1220 S. St Francis Dr.**  
**Santa Fe, NM 87505**

CONDITIONS

Action 573773

**CONDITIONS**

Operator: OXY USA INC P.O. Box 4294 Houston, TX 772104294	OGRID: 16696
	Action Number: 573773
	Action Type: [C-103A] NOI Change of Plans (C-103A)

**CONDITIONS**

Created By	Condition	Condition Date
ward.rikala	Cement is required to circulate on both surface and intermediate1 strings of casing.	4/21/2026
ward.rikala	Post Bradenhead cement squeeze, a CBL will be required. If zonal isolation was not achieved per OCD requirements, then remedial work is required before operations can continue.	4/21/2026
ward.rikala	Any previous COA's not addressed within the updated COA's still apply.	4/21/2026