

Well Name: KANGAROO 12 FEDERAL COM	Well Location: T20S / R28E / SEC 12 / NESW / 32.585507 / -104.13217	County or Parish/State: EDDY / NM
Well Number: 133H	Type of Well: OIL WELL	Allottee or Tribe Name:
Lease Number: NMNM2377	Unit or CA Name:	Unit or CA Number:
US Well Number: 3001547598	Operator: PERMIAN RESOURCES OPERATING LLC	

Notice of Intent

Sundry ID: 2790681

Type of Submission: Notice of Intent

Type of Action: APD Change

Date Sundry Submitted: 05/15/2024

Time Sundry Submitted: 04:56

Date proposed operation will begin: 07/19/2024

Procedure Description: Permian Resources Respectfully requests permission to make the following changes to the original APD: Big Fish 12-10 Federal Com 315H API# 30-015-47598 No Additional Surface Disturbance Name Change From: Big Fish 12-10 Federal Com 315H To: Kangaroo 12 Federal Com 133H, SHL: From: 1640' FSL & 2205' FWL, Sec. 12-T20S-R28E TO: 1612' FSL & 2279' FWL, Sec. 12-T20S-R28E KOP: From: 330' FSL & 2620' FWL, Sec. 12-T20S-R28E TO: 1612' FSL & 2279' FWL, Sec. 12-T20S-R28E FTP: From: 330' FSL & 2570' FWL, Sec. 12-T20S-R28E TO: 1658' FSL & 2540' FWL, Sec. 12-T20S-R28E PPP: From: did not note on original TO: 1656' FSL & 1329' FEL, Sec. 11-T20S-R28E PPP2: From: did not note on original TO: 1657' FSL & 2657' FEL, Sec. 11-T20S-R28E LTP: From: 330' FSL & 100' FWL, Sec 10-T20S-R28E TO: 1658' FSL & 100' FWL, Sec. 11-T20S-R28E BHL: From: 330' FSL & 20' FWL, Sec 10-T20S-R28E TO: 1658' FSL & 100' FWL, Sec. 11-T20S-R28E Casing/Cement design per the attached Drilling Program. Permian Resources also requests the following variances: BOP Break Test Procedure OLCV Batch Flexhose Variance Attachments: C102 Layout Drilling Program Spec Sheet – Inter & Prod Csg Directional Plan Multibowl Diagram 5MBOP/5MCM BOP Break Test Procedure OLCV Batch Flexhose Variance

NOI Attachments

Procedure Description

Kangaroo_12_Fed_Com_133H_Sundry_Attachments_20240710142918.pdf

Well Name: KANGAROO 12
FEDERAL COM

Well Location: T20S / R28E / SEC 12 /
NESW / 32.585507 / -104.13217

County or Parish/State: EDDY /
NM

Well Number: 133H

Type of Well: OIL WELL

Allottee or Tribe Name:

Lease Number: NMNM2377

Unit or CA Name:

Unit or CA Number:

US Well Number: 3001547598

Operator: PERMIAN RESOURCES
OPERATING LLC

Conditions of Approval

Additional

Sec_12_20S_28E_NMP_Sundry_2790681_Kangaroo_12_Federal_Com_133H_COAs_20240724093818.pdf

Operator

I certify that the foregoing is true and correct. Title 18 U.S.C. Section 1001 and Title 43 U.S.C. Section 1212, make it a crime for any person knowingly and willfully to make to any department or agency of the United States any false, fictitious or fraudulent statements or representations as to any matter within its jurisdiction. Electronic submission of Sundry Notices through this system satisfies regulations requiring a

Operator Electronic Signature: CASSIE EVANS

Signed on: JUL 17, 2024 07:55 AM

Name: PERMIAN RESOURCES OPERATING LLC

Title: Regulatory Specialist

Street Address: 300 N MARIENFELD ST STE 1000

City: MIDLAND

State: TX

Phone: (432) 260-4388

Email address: CASSIE.EVANS@PERMIANRES.COM

Field

Representative Name:

Street Address:

City:

State:

Zip:

Phone:

Email address:

BLM Point of Contact

BLM POC Name: CHRISTOPHER WALLS

BLM POC Title: Petroleum Engineer

BLM POC Phone: 5752342234

BLM POC Email Address: cwalls@blm.gov

Disposition: Approved

Disposition Date: 08/02/2024

Signature: Chris Walls

Form 3160-5
(June 2019)

UNITED STATES
DEPARTMENT OF THE INTERIOR
BUREAU OF LAND MANAGEMENT

FORM APPROVED
OMB No. 1004-0137
Expires: October 31, 2021

SUNDRY NOTICES AND REPORTS ON WELLS
Do not use this form for proposals to drill or to re-enter an abandoned well. Use Form 3160-3 (APD) for such proposals.

5. Lease Serial No. **NMNM2377**

6. If Indian, Allottee or Tribe Name

SUBMIT IN TRIPLICATE - Other instructions on page 2

1. Type of Well <input checked="" type="checkbox"/> Oil Well <input type="checkbox"/> Gas Well <input type="checkbox"/> Other		7. If Unit of CA/Agreement, Name and/or No.
2. Name of Operator PERMIAN RESOURCES OPERATING LLC		8. Well Name and No. KANGAROO 12 FEDERAL COM/133H
3a. Address 300 N MARIENFELD ST SUITE 1000, MIDLAND	3b. Phone No. (include area code) (432) 695-4222	9. API Well No. 3001547598
4. Location of Well (Footage, Sec., T.,R.,M., or Survey Description) SEC 12/T20S/R28E/NMP		10. Field and Pool or Exploratory Area OLD MILLMAN RANCH/BS (ASSOC)
		11. Country or Parish, State EDDY/NM

12. CHECK THE APPROPRIATE BOX(ES) TO INDICATE NATURE OF NOTICE, REPORT OR OTHER DATA

TYPE OF SUBMISSION	TYPE OF ACTION				
<input checked="" type="checkbox"/> Notice of Intent	<input type="checkbox"/> Acidize	<input type="checkbox"/> Deepen	<input type="checkbox"/> Production (Start/Resume)	<input type="checkbox"/> Water Shut-Off	
<input type="checkbox"/> Subsequent Report	<input type="checkbox"/> Alter Casing	<input type="checkbox"/> Hydraulic Fracturing	<input type="checkbox"/> Reclamation	<input type="checkbox"/> Well Integrity	
<input type="checkbox"/> Final Abandonment Notice	<input type="checkbox"/> Casing Repair	<input type="checkbox"/> New Construction	<input type="checkbox"/> Recomplete	<input type="checkbox"/> Other	
	<input checked="" type="checkbox"/> Change Plans	<input type="checkbox"/> Plug and Abandon	<input type="checkbox"/> Temporarily Abandon		
	<input type="checkbox"/> Convert to Injection	<input type="checkbox"/> Plug Back	<input type="checkbox"/> Water Disposal		

13. Describe Proposed or Completed Operation: Clearly state all pertinent details, including estimated starting date of any proposed work and approximate duration thereof. If

**Permian Resources Respectfully requests permission to make the following changes to the original APD:
Big Fish 12-10 Federal 315H API# 30-015-47598**

No Additional Surface Disturbance

Name Change From: Big Fish 12-10 Federal 315H To: Kangaroo 12 Federal Com 133H

SHL: From: 1640 FSL & 2205 FWL, Sec. 12-T20S-R28E TO: 1612 FSL & 2279 FWL, Sec. 12-T20S-R28E

KOP: From: 330 FSL & 2620 FWL, Sec. 12-T20S-R28E TO: 1612 FSL & 2279 FWL, Sec. 12-T20S-R28E

FTP: From: 330 FSL & 2570 FWL, Sec. 12-T20S-R28E TO: 1658 FSL & 2540 FWL, Sec. 12-T20S-R28E

PPP: From: did not note on original TO: 1656 FSL & 1329 FEL, Sec. 11-T20S-R28E

PPP2: From: did not note on original TO: 1657 FSL & 2657 FEL, Sec. 11-T20S-R28E

LTP: From: 330 FSL & 100 FWL, Sec 10-T20S-R28E TO: 1658 FSL & 100 FWL, Sec. 11-T20S-R28E

Continued on page 3 additional information

14. I hereby certify that the foregoing is true and correct. Name (Printed/Typed) CASSIE EVANS / Ph: (432) 260-4388	Title Regulatory Specialist
Signature (Electronic Submission)	Date 07/17/2024

THE SPACE FOR FEDERAL OR STATE OFFICE USE

Approved by CHRISTOPHER WALLS / Ph: (575) 234-2234 / Approved	Title Petroleum Engineer	Date 08/02/2024
Conditions of approval, if any, are attached. Approval of this notice does not warrant or certify that the applicant holds legal or equitable title to those rights in the subject lease which would entitle the applicant to conduct operations thereon.	Office CARLSBAD	

Title 18 U.S.C Section 1001 and Title 43 U.S.C Section 1212, make it a crime for any person knowingly and willfully to make to any department or agency of the United States any false, fictitious or fraudulent statements or representations as to any matter within its jurisdiction.

(Instructions on page 2)

GENERAL INSTRUCTIONS

This form is designed for submitting proposals to perform certain well operations and reports of such operations when completed as indicated on Federal and Indian lands pursuant to applicable Federal law and regulations. Any necessary special instructions concerning the use of this form and the number of copies to be submitted, particularly with regard to local area or regional procedures and practices, are either shown below, will be issued by or may be obtained from the local Federal office.

SPECIFIC INSTRUCTIONS

Item 4 - Locations on Federal or Indian land should be described in accordance with Federal requirements. Consult the local Federal office for specific instructions.

Item 13: Proposals to abandon a well and subsequent reports of abandonment should include such special information as is required by the local Federal office. In addition, such proposals and reports should include reasons for the abandonment; data on any former or present productive zones or other zones with present significant fluid contents not sealed off by cement or otherwise; depths (top and bottom) and method of placement of cement plugs; mud or other material placed below, between and above plugs; amount, size, method of parting of any casing, liner or tubing pulled and the depth to the top of any tubing left in the hole; method of closing top of well and date well site conditioned for final inspection looking for approval of the abandonment. If the proposal will involve **hydraulic fracturing operations**, you must comply with 43 CFR 3162.3-3, including providing information about the protection of usable water. Operators should provide the best available information about all formations containing water and their depths. This information could include data and interpretation of resistivity logs run on nearby wells. Information may also be obtained from state or tribal regulatory agencies and from local BLM offices.

NOTICES

The privacy Act of 1974 and the regulation in 43 CFR 2.48(d) provide that you be furnished the following information in connection with information required by this application.

AUTHORITY: 30 U.S.C. 181 et seq., 351 et seq., 25 U.S.C. 396; 43 CFR 3160.

PRINCIPAL PURPOSE: The information is used to: (1) Evaluate, when appropriate, approve applications, and report completion of subsequent well operations, on a Federal or Indian lease; and (2) document for administrative use, information for the management, disposal and use of National Resource lands and resources, such as: (a) evaluating the equipment and procedures to be used during a proposed subsequent well operation and reviewing the completed well operations for compliance with the approved plan; (b) requesting and granting approval to perform those actions covered by 43 CFR 3162.3-2, 3162.3-3, and 3162.3-4; (c) reporting the beginning or resumption of production, as required by 43 CFR 3162.4-1(c) and (d) analyzing future applications to drill or modify operations in light of data obtained and methods used.

ROUTINE USES: Information from the record and/or the record will be transferred to appropriate Federal, State, local or foreign agencies, when relevant to civil, criminal or regulatory investigations or prosecutions in connection with congressional inquiries or to consumer reporting agencies to facilitate collection of debts owed the Government.

EFFECT OF NOT PROVIDING THE INFORMATION: Filing of this notice and report and disclosure of the information is mandatory for those subsequent well operations specified in 43 CFR 3162.3-2, 3162.3-3, 3162.3-4.

The Paperwork Reduction Act of 1995 requires us to inform you that:

The BLM collects this information to evaluate proposed and/or completed subsequent well operations on Federal or Indian oil and gas leases.

Response to this request is mandatory.

The BLM would like you to know that you do not have to respond to this or any other Federal agency-sponsored information collection unless it displays a currently valid OMB control number.

BURDEN HOURS STATEMENT: Public reporting burden for this form is estimated to average 8 hours per response, including the time for reviewing instructions, gathering and maintaining data, and completing and reviewing the form. Direct comments regarding the burden estimate or any other aspect of this form to U.S. Department of the Interior, Bureau of Land Management (1004-0137), Bureau Information Collection Clearance Officer (WO-630), 1849 C St., N.W., Mail Stop 401 LS, Washington, D.C. 20240

Additional Information

Additional Remarks

BHL: From: 330 FSL & 20 FWL, Sec 10-T20S-R28E TO: 1658 FSL & 100 FWL, Sec. 11-T20S-R28E

Casing/Cement design per the attached Drilling Program.

Permian Resources also requests the following variances:

BOP Break Test Procedure

OLCV

Batch

Flexhose Variance

Attachments:

C102

Layout

Drilling Program

Spec Sheet Inter & Prod Csg

Directional Plan

Multibowl Diagram

5MBOP/5MCM

BOP Break Test Procedure

OLCV

Batch

Flexhose Variance

Location of Well

0. SHL: NESW / 1640 FSL / 2205 FWL / TWSP: 20S / RANGE: 28E / SECTION: 12 / LAT: 32.585507 / LONG: -104.13217 (TVD: 0 feet, MD: 0 feet)

PPP: SESW / 320 FSL / 2656 FEL / TWSP: 20S / RANGE: 28E / SECTION: 11 / LAT: 32.581866 / LONG: -104.148013 (TVD: 8840 feet, MD: 14714 feet)

PPP: SESW / 330 FSL / 2570 FWL / TWSP: 20S / RANGE: 28E / SECTION: 12 / LAT: 32.581906 / LONG: -104.131045 (TVD: 8907 feet, MD: 9487 feet)

BHL: SWSW / 330 FSL / 20 FWL / TWSP: 20S / RANGE: 28E / SECTION: 10 / LAT: 32.581803 / LONG: -104.173851 (TVD: 8739 feet, MD: 22674 feet)

PECOS DISTRICT DRILLING CONDITIONS OF APPROVAL

OPERATOR'S NAME: Permian Resources Operating LLC
WELL NAME & NO.: Kangaroo 12 Federal Com 133H
LOCATION: Sec 12-20S-28E-NMP
COUNTY: Eddy County, New Mexico

*Changes approved through engineering via **Sundry 2790681** on 07/23/2024. Any previous COAs not addressed within the updated COAs still apply.*

COA

H ₂ S	<input checked="" type="radio"/> No		<input type="radio"/> Yes	
Potash / WIPP	<input checked="" type="radio"/> None	<input type="radio"/> Secretary	<input type="radio"/> R-111-Q	<input type="checkbox"/> Open Annulus <input type="checkbox"/> WIPP
Cave / Karst	<input type="radio"/> Low	<input type="radio"/> Medium	<input checked="" type="radio"/> High	<input type="radio"/> Critical
Wellhead	<input type="radio"/> Conventional	<input checked="" type="radio"/> Multibowl	<input type="radio"/> Both	<input type="radio"/> Diverter
Cementing	<input type="checkbox"/> Primary Squeeze	<input type="checkbox"/> Cont. Squeeze	<input type="checkbox"/> EchoMeter	<input type="checkbox"/> DV Tool
Special Req	<input checked="" type="checkbox"/> Capitan Reef	<input type="checkbox"/> Water Disposal	<input checked="" type="checkbox"/> COM	<input type="checkbox"/> Unit
Waste Prev.	<input type="radio"/> Self-Certification	<input type="radio"/> Waste Min. Plan	<input checked="" type="radio"/> APD Submitted prior to 06/10/2024	
Additional Language	<input checked="" type="checkbox"/> Flex Hose	<input type="checkbox"/> Casing Clearance	<input type="checkbox"/> Pilot Hole	<input checked="" type="checkbox"/> Break Testing
	<input checked="" type="checkbox"/> Four-String	<input checked="" type="checkbox"/> Offline Cementing	<input type="checkbox"/> Fluid-Filled	

Language Inconsistency within Submittal: Break testing must be performed at 21-day intervals per API Standard. If you are testing the BOP every 30 days, you are not approved for break testing.

A. HYDROGEN SULFIDE

Hydrogen Sulfide (H₂S) monitors shall be installed prior to drilling out the surface shoe. If H₂S is detected in concentrations greater than 100 ppm, the Hydrogen Sulfide area shall meet 43 CFR 3176 requirements, which includes equipment and personnel/public protection items. If Hydrogen Sulfide is encountered, provide measured values and formations to the BLM.

B. CASING

1. The **13-3/8** inch surface casing shall be set at approximately **178** feet (a minimum of 70 feet (Eddy County) into the Rustler Anhydrite, above the salt, and below usable fresh water) and cemented to the surface.
 - a. If cement does not circulate to the surface, the appropriate BLM office shall be notified and a temperature survey utilizing an electronic type temperature survey with surface log readout

will be used or a cement bond log shall be run to verify the top of the cement. Temperature survey will be run a minimum of six hours after pumping cement and ideally between 8-10 hours after completing the cement job.

- b. Wait on cement (WOC) time for a primary cement job will be a minimum of **8 hours** or **500 pounds compressive strength**, whichever is greater. (This is to include the lead cement)
 - c. Wait on cement (WOC) time for a remedial job will be a minimum of 4 hours after bringing cement to surface or 500 pounds compressive strength, whichever is greater.
 - d. If cement falls back, remedial cementing will be done prior to drilling out that string.
2. The minimum required fill of cement behind the **10-3/4** inch intermediate casing is:
- Cement to surface. If cement does not circulate see B.1.a, c-d above. **Wait on cement (WOC) time for a primary cement job is to include the lead cement slurry due to cave/karst, Capitan Reef, or potash.**
 - ❖ In High Cave/Karst Areas if cement does not circulate to surface on the first two casing strings, the cement on the 3rd casing string must come to surface.
 - ❖ In Capitan Reef Areas if cement does not circulate to surface on the first two casing strings, the cement on the 3rd casing string must come to surface.
 - ❖ **Special Capitan Reef requirements.** Freshwater based mud must be used across the Capitan interval.
3. The minimum required fill of cement behind the **8-5/8** inch intermediate casing is:
- Cement should tie-back at least **50 feet** on top of Capitan Reef top or **200 feet** into the previous casing, whichever is greater. If cement does not circulate see B.1.a, c-d above. **Wait on cement (WOC) time for a primary cement job is to include the lead cement slurry due to cave/karst, Capitan Reef, or potash.**
4. The minimum required fill of cement behind the **5-1/2** inch production casing is:
- Cement should tie-back at least **200 feet** into previous casing string. Operator shall provide method of verification. **Wait on cement (WOC) time for a primary cement job is to include the lead cement slurry due to cave/karst, Capitan Reef, or potash.**

C. PRESSURE CONTROL

1. Variance approved to use flex line from BOP to choke manifold. Manufacturer's specification to be readily available. No external damage to flex line. Flex line to be installed as straight as possible (no hard bends).
2. Operator has proposed a multi-bowl wellhead assembly. Minimum working pressure of the blowout preventer (BOP) and related equipment (BOPE) required for drilling below the surface casing shoe shall be **5000 (5M)** psi.

- a. Wellhead shall be installed by manufacturer's representatives, submit documentation with subsequent sundry.
- b. If the welding is performed by a third party, the manufacturer's representative shall monitor the temperature to verify that it does not exceed the maximum temperature of the seal.
- c. Manufacturer representative shall install the test plug for the initial BOP test.
- d. If the cement does not circulate and one-inch operations would have been possible with a standard wellhead, the well head shall be cut off, cementing operations performed and another wellhead installed.
- e. Whenever any seal subject to test pressure is broken, all the tests in 43 CFR 3172 must be followed.

D. SPECIAL REQUIREMENT (S)

Communitization Agreement

- The operator will submit a Communitization Agreement to the Santa Fe Office, 301 Dinosaur Trail Santa Fe, New Mexico 87508, at least 90 days before the anticipated date of first production from a well subject to a spacing order issued by the New Mexico Oil Conservation Division. The Communitization Agreement will include the signatures of all working interest owners in all Federal and Indian leases subject to the Communitization Agreement (i.e., operating rights owners and lessees of record), or certification that the operator has obtained the written signatures of all such owners and will make those signatures available to the BLM immediately upon request.
- The operator will submit an as-drilled survey well plat of the well completion, but are not limited to, those specified in 43 CFR 3171 and 3172.
- If the operator does not comply with this condition of approval, the BLM may take enforcement actions that include, but are not limited to, those specified in 43 CFR 3163.1.
- In addition, the well sign shall include the surface and bottom hole lease numbers. When the Communitization Agreement number is known, it shall also be on the sign.

BOPE Break Testing Variance

- BOPE Break Testing is ONLY permitted for intervals utilizing a 5M BOPE or less. **(Annular preventer must be tested to a minimum of 70% of BOPE working pressure and shall be higher than the MASP.)**
- BOPE Break Testing is NOT permitted to drilling the production hole section.
- Variance only pertains to the intermediate hole-sections and no deeper than the Bone Springs formation.
- While in transfer between wells, the BOPE shall be secured by the hydraulic carrier or cradle.
- Any well control event while drilling require notification to the BLM Petroleum Engineer (575-706-2779) prior to the commencement of any BOPE Break Testing operations.
- A full BOPE test is required prior to drilling the first deep intermediate hole section. If any subsequent hole interval is deeper than the first, a full BOPE test will be required. (200' TVD tolerance between intermediate shoes is allowable).
- The BLM is to be contacted (575-361-2822 Eddy County) 4 hours prior to BOPE tests.
- As a minimum, a full BOPE test shall be performed at 21-day intervals.

- In the event any repairs or replacement of the BOPE is required, the BOPE shall test as per **43 CFR 3172**.
- If in the event break testing is not utilized, then a full BOPE test would be conducted.

Offline Cementing

Contact the BLM prior to the commencement of any offline cementing procedure.

GENERAL REQUIREMENTS

The BLM is to be notified in advance for a representative to witness:

- a. Spudding well (minimum of 24 hours)
- b. Setting and/or Cementing of all casing strings (minimum of 4 hours)
- c. BOPE tests (minimum of 4 hours)

Contact Eddy County Petroleum Engineering Inspection Staff:

Email or call the Carlsbad Field Office, 620 East Greene St., Carlsbad, NM 88220;

BLM NM CFO DrillingNotifications@BLM.GOV; (575) 361-2822

1. Unless the production casing has been run and cemented or the well has been properly plugged, the drilling rig shall not be removed from over the hole without prior approval.
 - a. In the event the operator has proposed to drill multiple wells utilizing a skid/walking rig. Operator shall secure the wellbore on the current well, after installing and testing the wellhead, by installing a blind flange of like pressure rating to the wellhead and a pressure gauge that can be monitored while drilling is performed on the other well(s).
 - b. When the operator proposes to set surface casing with Spudder Rig
 - i. Notify the BLM when moving in and removing the Spudder Rig.
 - ii. Notify the BLM when moving in the 2nd Rig. Rig to be moved in within 90 days of notification that Spudder Rig has left the location.
 - iii. BOP/BOPE test to be conducted per **43 CFR 3172** as soon as 2nd Rig is rigged up on well.
2. Floor controls are required for 3M or Greater systems. These controls will be on the rig floor, unobstructed, readily accessible to the driller and will be operational at all times during drilling and/or completion activities. Rig floor is defined as the area immediately around the rotary table; the area immediately above the substructure on which the draw works are located, this does not include the dog house or stairway area.
3. For intervals in which cement to surface is required, cement to surface should be verified with a visual check and density or pH check to differentiate cement from spacer and drilling mud. The results should be documented in the driller's log and daily reports.

A. CASING

1. Changes to the approved APD casing program need prior approval if the items substituted are of lesser grade or different casing size or are Non-API. The Operator can exchange the components of the proposal with that of superior strength (i.e. changing from J-55 to N-80, or from 36# to 40#). Changes to the approved cement program need prior approval if the altered cement plan has less volume or strength or if the changes are substantial (i.e. Multistage tool, ECP, etc.). The initial wellhead installed on the well will remain on the well with spools used as needed.
2. Wait on cement (WOC) for Potash Areas: After cementing but before commencing any tests, the casing string shall stand cemented under pressure until both of the following

- conditions have been met: 1) cement reaches a minimum compressive strength of 500 psi for all cement blends of both lead and tail cement, 2) until cement has been in place at least 8 hours. WOC time will be recorded in the driller's log. The casing integrity test can be done (prior to the cement setting up) immediately after bumping the plug.
3. Wait on cement (WOC) for Water Basin: After cementing but before commencing any tests, the casing string shall stand cemented under pressure until both of the following conditions have been met: 1) cement reaches a minimum compressive strength of 500 psi at the shoe, 2) until cement has been in place at least 8 hours. WOC time will be recorded in the driller's log. See individual casing strings for details regarding lead cement slurry requirements. The casing integrity test can be done (prior to the cement setting up) immediately after bumping the plug.
 4. Provide compressive strengths including hours to reach required 500 pounds compressive strength prior to cementing each casing string. Have well specific cement details onsite prior to pumping the cement for each casing string.
 5. No pea gravel permitted for remedial or fall back remedial without prior authorization from the BLM engineer.
 6. On that portion of any well approved for a 5M BOPE system or greater, a pressure integrity test of each casing shoe shall be performed. Formation at the shoe shall be tested to a minimum of the mud weight equivalent anticipated to control the formation pressure to the next casing depth or at total depth of the well. This test shall be performed before drilling more than 20 feet of new hole.
 7. If hardband drill pipe is rotated inside casing, returns will be monitored for metal. If metal is found in samples, drill pipe will be pulled and rubber protectors which have a larger diameter than the tool joints of the drill pipe will be installed prior to continuing drilling operations.
 8. Whenever a casing string is cemented in the R-111-Q potash area, the NMOCD requirements shall be followed.

B. PRESSURE CONTROL

1. All blowout preventer (BOP) and related equipment (BOPE) shall comply with well control requirements as described in **43 CFR 3172**.
2. If a variance is approved for a flexible hose to be installed from the BOP to the choke manifold, the following requirements apply: The flex line must meet the requirements of API 16C. Check condition of flexible line from BOP to choke manifold, replace if exterior is damaged or if line fails test. Line to be as straight as possible with no hard bends and is to be anchored according to Manufacturer's requirements. The flexible hose can be exchanged with a hose of equal size and equal or greater pressure rating. Anchor requirements, specification sheet and hydrostatic pressure test certification matching the hose in service, to be onsite for review. These documents shall be posted in the company man's trailer and on the rig floor.

3. 5M or higher system requires an HCR valve, remote kill line and annular to match. The remote kill line is to be installed prior to testing the system and tested to stack pressure.
4. If the operator has proposed a multi-bowl wellhead assembly in the APD. The following requirements must be met:
 - i. Wellhead shall be installed by manufacturer's representatives, submit documentation with subsequent sundry.
 - ii. If the welding is performed by a third party, the manufacturer's representative shall monitor the temperature to verify that it does not exceed the maximum temperature of the seal.
 - iii. Manufacturer representative shall install the test plug for the initial BOP test.
 - iv. Whenever any seal subject to test pressure is broken, all the tests in 43 CFR 3172.6(b)(9) must be followed.
 - v. If the cement does not circulate and one inch operations would have been possible with a standard wellhead, the well head shall be cut off, cementing operations performed and another wellhead installed.
5. The appropriate BLM office shall be notified a minimum of 4 hours in advance for a representative to witness the tests.
 - i. In a water basin, for all casing strings utilizing slips, these are to be set as soon as the crew and rig are ready and any fallback cement remediation has been done. The casing cut-off and BOP installation can be initiated four hours after installing the slips, which will be approximately six hours after bumping the plug. For those casing strings not using slips, the minimum wait time before cut-off is eight hours after bumping the plug. BOP/BOPE testing can begin after cut-off or once cement reaches 500 psi compressive strength (including lead cement), whichever is greater. However, if the float does not hold, cut-off cannot be initiated until cement reaches 500 psi compressive strength (including lead when specified).
 - ii. In potash areas, for all casing strings utilizing slips, these are to be set as soon as the crew and rig are ready and any fallback cement remediation has been done. For all casing strings, casing cut-off and BOP installation can be initiated at twelve hours after bumping the cement plug. The BOPE test can be initiated after bumping the cement plug with the casing valve open. (only applies to single stage cement jobs, prior to the cement setting up.)
 - iii. The tests shall be done by an independent service company utilizing a test plug not a cup or J-packer and can be initiated immediately with the casing valve open. The operator also has the option of utilizing an independent tester to test without a plug (i.e. against the casing) pursuant to **43 CFR 3172** with the pressure not to exceed 70% of the burst rating for the casing. Any test against the casing must meet the WOC time for 8 hours or 500 pounds compressive strength, whichever is greater, prior to initiating the test (see casing segment as lead cement may be critical item).

- iv. The test shall be run on a 5000 psi chart for a 2-3M BOP/BOP, on a 10000 psi chart for a 5M BOP/BOPE and on a 15000 psi chart for a 10M BOP/BOPE. If a linear chart is used, it shall be a one hour chart. A circular chart shall have a maximum 2 hour clock. If a twelve hour or twenty-four hour chart is used, tester shall make a notation that it is run with a two hour clock.
- v. The results of the test shall be reported to the appropriate BLM office.
- vi. All tests are required to be recorded on a calibrated test chart. A copy of the BOP/BOPE test chart and a copy of independent service company test will be submitted to the appropriate BLM office.
- vii. The BOP/BOPE test shall include a low pressure test from 250 to 300 psi. The test will be held for a minimum of 10 minutes if test is done with a test plug and 30 minutes without a test plug. This test shall be performed prior to the test at full stack pressure.
- viii. BOP/BOPE must be tested by an independent service company within 500 feet of the top of the Wolfcamp formation if the time between the setting of the intermediate casing and reaching this depth exceeds 20 days. This test does not exclude the test prior to drilling out the casing shoe as per **43 CFR 3172**.

C. DRILLING MUD

Mud system monitoring equipment, with derrick floor indicators and visual and audio alarms, shall be operating before drilling into the Wolfcamp formation, and shall be used until production casing is run and cemented.

D. WASTE MATERIAL AND FLUIDS

All waste (i.e. drilling fluids, trash, salts, chemicals, sewage, gray water, etc.) created as a result of drilling operations and completion operations shall be safely contained and disposed of properly at a waste disposal facility. No waste material or fluid shall be disposed of on the well location or surrounding area. Porto-johns and trash containers will be on-location during fracturing operations or any other crew-intensive operations.

District I
1625 N. French Dr., Hobbs, NM 88240
Phone: (575) 393-6161 Fax: (575) 393-0720
District II
811 S. First St., Artesia, NM 88210
Phone: (575) 748-1283 Fax: (575) 748-9720
District III
1000 Rio Brazos Road, Aztec, NM 87410
Phone: (505) 334-6178 Fax: (505) 334-6170
District IV
1220 S. St. Francis Dr., Santa Fe, NM 87505
Phone: (505) 476-3460 Fax: (505) 476-3462

State of New Mexico
Energy, Minerals & Natural Resources Department
OIL CONSERVATION DIVISION
1220 South St. Francis Dr.
Santa Fe, NM 87505

Form C-102
Revised August 1, 2011
Submit one copy to appropriate
District Office

AMENDED REPORT

WELL LOCATION AND ACREAGE DEDICATION PLAT

¹ API Number 30-015-47598	² Pool Code 48035	³ Pool Name Old Millman Ranch; BS (ASSOC)
⁴ Property Code	⁵ Property Name KANGAROO 12 FED COM	⁶ Well Number 133H
⁷ OGRID No. 372165	⁸ Operator Name PERMIAN RESOURCES OPERATING, LLC	⁹ Elevation 3258.6'

¹⁰ Surface Location

UL or lot no. K	Section 12	Township 20S	Range 28E	Lot Idn	Feet from the 1612	North/South line SOUTH	Feet from the 2279	East/West line WEST	County EDDY
--------------------	---------------	-----------------	--------------	---------	-----------------------	---------------------------	-----------------------	------------------------	----------------

¹¹ Bottom Hole Location If Different From Surface

UL or lot no. L	Section 11	Township 20S	Range 28E	Lot Idn	Feet from the 1658	North/South line SOUTH	Feet from the 100	East/West line WEST	County EDDY
¹² Dedicated Acres 240	¹³ Joint or Infill	¹⁴ Consolidation Code	¹⁵ Order No.						

No allowable will be assigned to this completion until all interests have been consolidated or a non-standard unit has been approved by the division.

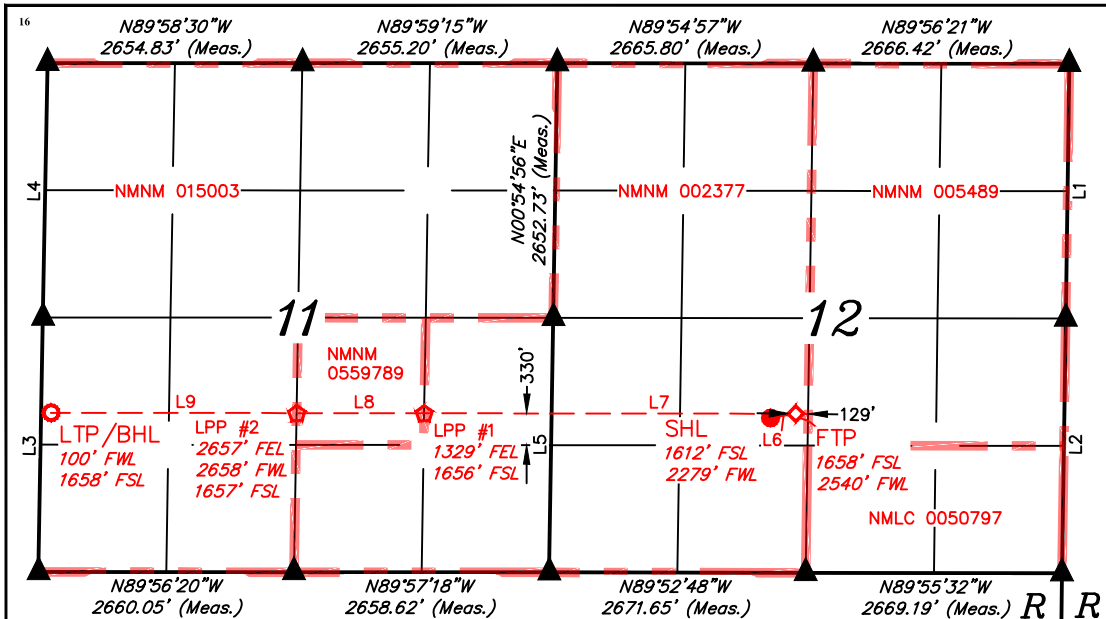

¹⁷ OPERATOR CERTIFICATION
I hereby certify that the information contained herein is true and complete to the best of my knowledge and belief, and that this organization either owns a working interest or unleased mineral interest in the land including the proposed bottom hole location or has a right to drill this well at this location pursuant to a contract with an owner of such a mineral or working interest, or to a voluntary pooling agreement or a compulsory pooling order heretofore entered by the division.
Cassie Evans 5/14/24
Signature Date
Cassie Evans
Printed Name
Cassie.Evans@permianres.com
E-mail Address

- = SURFACE HOLE LOCATION.
- ◆ = FIRST TAKE POINT.
- ◇ = LEASE PENETRATION POINT.
- = LAST TAKE POINT/
BOTTOM HOLE LOCATION.
- ▲ = SECTION CORNER LOCATED.
- = LEASE LINE.

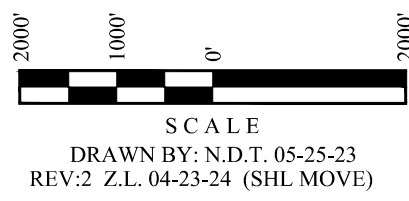

¹⁸ SURVEYOR CERTIFICATION
I hereby certify that the well location shown on this plat was plotted from field notes of actual surveys made by me or under my supervision, and that the same is true and correct to the best of my belief.
April 18, 2024
Date of Survey
Signature and Seal of Professional Surveyor:

NAD 83 (SURFACE HOLE LOCATION) LATITUDE = 32°35'07.55" (32.585429°) LONGITUDE = -104°07'54.97" (-104.131936°)	NAD 83 (FIRST TAKE POINT) LATITUDE = 32°35'08.00" (32.585554°) LONGITUDE = -104°07'51.91" (-104.131085°)
NAD 27 (SURFACE HOLE LOCATION) LATITUDE = 32°35'07.12" (32.585311°) LONGITUDE = -104°07'53.15" (-104.131430°)	NAD 27 (FIRST TAKE POINT) LATITUDE = 32°35'07.57" (32.585436°) LONGITUDE = -104°07'50.09" (-104.130579°)
STATE PLANE NAD 83 (N.M. EAST) N: 576768.62' E: 603368.44'	STATE PLANE NAD 83 (N.M. EAST) N: 576814.53' E: 603630.33'
STATE PLANE NAD 27 (N.M. EAST) N: 576707.06' E: 562188.20'	STATE PLANE NAD 27 (N.M. EAST) N: 576752.96' E: 562450.09'

NAD 83 (LPP #1) LATITUDE = 32°35'07.95" (32.585543°) LONGITUDE = -104°08'37.12" (-104.143644°)	NAD 83 (LPP #2) LATITUDE = 32°35'07.94" (32.585539°) LONGITUDE = -104°08'52.65" (-104.147958°)
NAD 27 (LPP #1) LATITUDE = 32°35'07.53" (32.585425°) LONGITUDE = -104°08'35.30" (-104.143138°)	NAD 27 (LPP #2) LATITUDE = 32°35'07.51" (32.585421°) LONGITUDE = -104°08'50.82" (-104.147451°)
STATE PLANE NAD 83 (N.M. EAST) N: 576803.24' E: 599762.12'	STATE PLANE NAD 83 (N.M. EAST) N: 576799.36' E: 598433.60'
STATE PLANE NAD 27 (N.M. EAST) N: 576741.70' E: 558581.89'	STATE PLANE NAD 27 (N.M. EAST) N: 576737.84' E: 557253.38'

NAD 83 (LTP/BHL) LATITUDE = 32°35'07.91" (32.585530°) LONGITUDE = -104°09'22.54" (-104.156262°)	NAD 83 (LTP/BHL) LATITUDE = 32°35'07.48" (32.585412°) LONGITUDE = -104°09'20.72" (-104.155755°)
STATE PLANE NAD 83 (N.M. EAST) N: 576791.90' E: 595875.87'	STATE PLANE NAD 83 (N.M. EAST) N: 576791.90' E: 595875.87'
STATE PLANE NAD 27 (N.M. EAST) N: 576730.39' E: 554695.66'	STATE PLANE NAD 27 (N.M. EAST) N: 576730.39' E: 554695.66'

- NOTE:**
- Distances referenced on plat to section lines are perpendicular.
 - Basis of Bearings is a Transverse Mercator Projection with a Central Meridian of W103°53'00" (NAD 83)



Certificate Number:

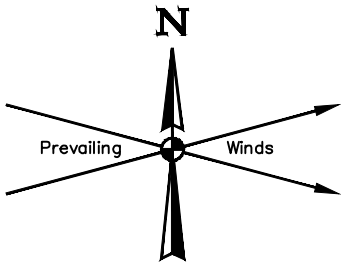

CERTIFICATE
 THIS MAP HAS BEEN PRODUCED ACCORDING TO PROCEDURES THAT HAVE BEEN DEMONSTRATED TO PRODUCE DATA THAT MEETS OR EXCEEDS THE MINIMUM STANDARDS FOR A TOPOGRAPHIC MAP COMPILED AT A SCALE OF 1" = 100' WITH A CONTOUR INTERVAL OF 2'

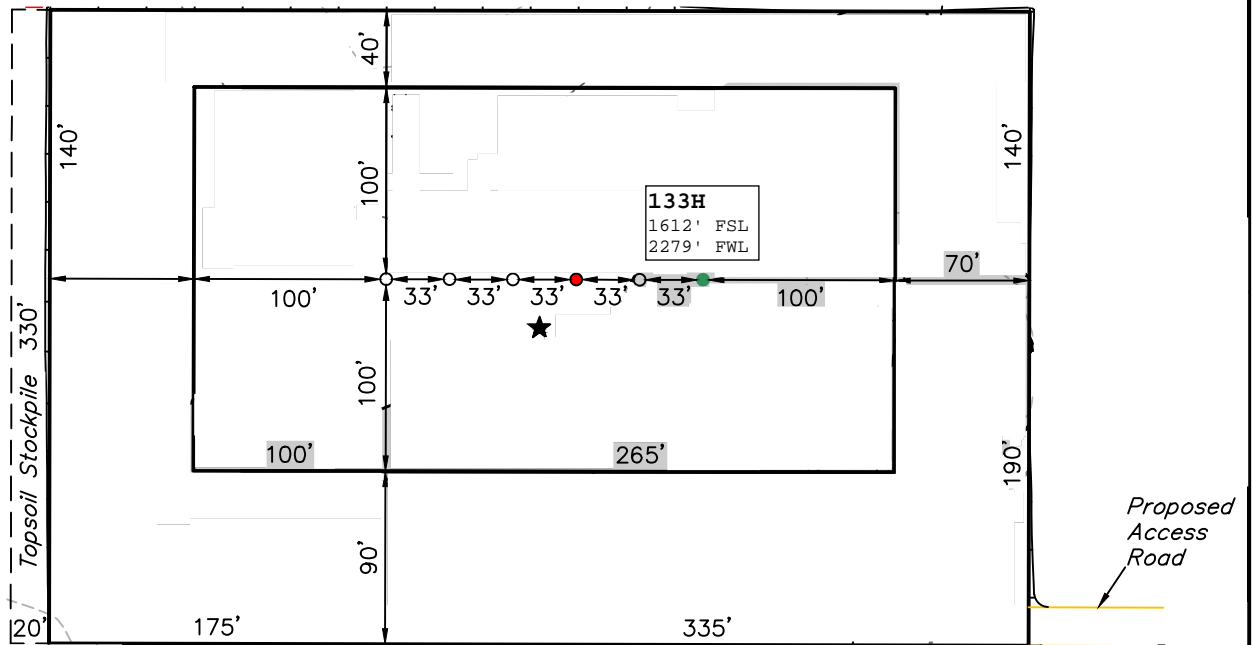
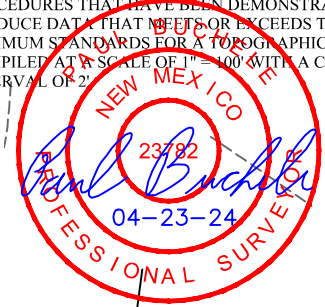

● Old Original APD Location

● New Sundry Location

NOTE: Earthwork Calculations Require a Fill @ Some of the Location Stakes For Balance. All Fill is to be Compacted to a Minimum of 95% of the Maximum Dry Density Obtained by AASHTO Method t-99.

REV: 2 4-24-24 Z.L. (PAD MOVE)

NOTES:

- Contours shown at 2' intervals.
- Cut/Fill Slopes 2:1 (Typ.)
- Underground utilities shown on this sheet are for visualization purposes only, actual locations to be determined prior to construction.
- Basis of Bearings is a Transverse Mercator Projection with a Central Meridian of W103°53'00" (NAD 83)

PERMIAN RESOURCES OPERATING, LLC

**KANGAROO 12-11 FEDERAL COM NESW 1
 NE 1/4 SW 1/4, SECTION 12, T20S, R28E, N.M.P.M.
 EDDY COUNTY, NEW MEXICO**

SURVEYED BY	A.V.	04-18-24	SCALE
DRAWN BY	D.J.S.	05-31-23	1" = 100'

LOCATION LAYOUT



UELS, LLC
 Corporate Office * 85 South 200 East
 Vernal, UT 84078 * (435) 789-1017

Permian Resources - Kangaroo 12 Fed Com 133H

1. Geologic Formations

Formation	Lithology	Elevation	TVD	Target
Rustler	Sandstone	3135	153	No
Top of Salt	Salt	2935	353	No
Tansill	Sandstone	2510	778	No
Yates	Anhydrite/Shale	2385	903	No
Seven Rivers	Limestone	2010	1278	No
Capitan	Sandstone	1945	1343	No
Delaware Sands	Sandstone	35	3253	No
Brushy Canyon	Sandstone	-535	3823	No
Bone Spring Lime	Limestone/Shale	-1915	5203	No
1st Bone Spring Sand	Sandstone/Limestone/Shale	-3490	6778	No
2nd Bone Spring Sand	Sandstone/Limestone/Shale	-4140	7428	No
3rd Bone Spring Sand	Sandstone/Limestone/Shale	-5315	8603	Yes
Wolfcamp	Shale	-5715	9003	No

2. Blowout Prevention

BOP installed and tested before drilling	Size?	Min. Required WP	Type	x	Tested to:
12.25	13-5/8"	5M	Annular	x	2500 psi
			Blind Ram	x	5000 psi
			Pipe Ram	x	
			Double Ram		
			Other*		
9.875	13-5/8"	5M	Annular	x	2500 psi
			Blind Ram	x	5000 psi
			Pipe Ram	x	
			Double Ram		
			Other*		
7.875	13-5/8"	5M	Annular	x	2500 psi
			Blind Ram	x	5000 psi
			Pipe Ram	x	
			Double Ram		
			Other*		

Equipment: BOPE with working pressure ratings in excess of anticipated maximum surface pressure will be utilized for well control from drill out of surface casing to TMD. The System may be upgraded to a higher pressure but still tested to the working pressure listed in the table above. If the system is upgraded all the components installed will be functional and tested. All BOPE connections shall be flanged, welded or clamped. All choke lines shall be straight unless targeted with running tees or tee blocks are used, and choke lines shall be anchored to prevent whip and reduce vibrations. All valves in the choke line & the choke manifold shall be full opening as to not cause restrictions and to allow for straight fluid paths to minimize potential erosion. All gauges utilized in the well control system shall be of a type designed for drilling fluid service. A top drive inside BOP valve will be utilized at all times. Subs equipped with full opening valves sized to fit the drill pipe and collars will be available on the rig floor in the open position. The key to operate said valve equipped subs will be on the rig floor at all times. The accumulator system will have sufficient capacity to open the HCR and close all three sets of rams plus the annular preventer while retaining at least 300 psi above precharge on the closing manifold (accumulator system shall be capable of doing so without using the closing unit pumps). The fluid reservoir capacity will be double the usable fluid volume of the accumulator system capacity, and the fluid level will be maintained at the manufacturer's recommended level. Prior to connecting the closing unit to the BOP stack, an accumulator precharge pressure test shall be performed to ensure the precharge pressure is within 100 psi of the desired precharge pressure (only nitrogen gas will be used to precharge). Two independent power sources will be made available at all times to power the closing unit pumps so that the pumps can automatically start when the closing valve manifold pressure has decreased to the preset level. Closing unit pumps will be sized to allow opening of HCR and closing of annular preventer on 5" drill pipe achieving at least 200 psi above precharge pressure with the accumulator system isolated from service in less than two minutes. A valve shall be installed in the closing line as close to the annular preventer as possible to act as a locking device; the valve shall be maintained in the open position and shall be closed only when the power source for the accumulator system is inoperative. Remote controls capable of opening and closing all preventers & the HCR shall be readily accessible to the driller; master controls with the same capability will be operable at the accumulator. The wellhead will be a multibowl speed head allowing for hangoff of intermediate casing & isolation of the 133/8 x 95/8 annulus without breaking the connection between the BOP & wellhead to install an additional casing head. A wear bushing will be installed & inspected frequently to guard against internal wear to wellhead. VBRs (variablebore rams) will be run in upper rambody of BOP stack to provide redundancy to annular preventer while RIH w/ production casing;

Requesting Variance? YES

Variance request: Break testing, flex hose, and offline cement variances, see attachments in section 8.

Testing Procedure: BOP/BOPE will be tested by an independent service company to 250 psi low and the high pressure indicated above per Onshore Order II requirements. The BOP test shall be performed before drilling out of the surface casing shoe and will occur at a minimum: a. when initially installed b. whenever any seal subject to test pressure is broken c. following related repairs d. at 30 day intervals e. checked daily as to mechanical operating conditions. The ram type preventer(s) will be tested using a test plug to 250 psi (low) and 5,000 psi (high) (casinghead WP) with a test plug upon its installation onto the 13 surface casing. If a test plug is not used, the ram type preventer(s) shall be tested to 70% of the minimum internal yield pressure of the casing. The annular type preventer(s) shall be tested to 3500 psi. Pressure will be maintained for at least 10 minutes or until provisions of the test are met, whichever is longer. A Sundry Notice (Form 3160 5), along with a copy of the BOP test report, shall be submitted to the local BLM office within 5 working days following the test. If the bleed line is connected into the buffer tank (header), all BOP equipment including the buffer tank and associated valves will be rated at the required BOP pressure. The BLM office will be provided with a minimum of four (4) hours notice of BOP testing to allow witnessing. The BOP Configuration, choke manifold layout, and accumulator system, will be in compliance with Onshore Order 2 for a 5,000 psi system. A remote accumulator and a multi-bowl system will be used, please see attachment in section 8 for multi-bowl procedure. Pressures, capacities, and specific placement and use of the manual and/or hydraulic controls, accumulator controls, bleed lines, etc., will be identified at the time of the BLM 'witnessed BOP test. Any remote controls will be capable of both opening and closing all preventers and shall be readily accessible.

Pipe rams will be operationally checked each 24-hour period. Blind rams will be operationally checked on each trip out of the hole. These checked will be noted on the daily tour sheets. Other accessories to the BOP equipment will include a Kelly cock and floor safety valve (inside BOP), choke lines, and choke manifold. See attached schematics.

Choke Diagram Attachment: 5M Choke Manifold

BOP Diagram Attachment: BOP Schematics

3. Casing

String	Hole Size	Casing Size	Top	Bottom	Top TVD	Bottom TVD	Length	Grade	Weight	Connection	Collapse SF	Burst SF	Joint SF Type	Joint SF	Body SF Type	Body SF
Surface	17.5	13.375	0	178	0	178	178	J55	54.5	BTC	12.85	8.12	Dry	8.29	Dry	7.78
Intermediate 1	12.25	10.75	0	803	0	803	803	J55	45.5	BTC	11.74	4.57	Dry	7.79	Dry	7.62
Intermediate 2	9.875	8.625	0	3203	0	3203	3203	P110 HS	32	MO-FXL	5.79	2.52	Dry	3.90	Dry	5.65
Production	7.875	5.5	0	9163	0	8850	9163	P110RY	17	GeoConn	2.41	2.52	Dry	2.56	Dry	2.56
Production	7.875	5.5	9163	16672	8850	8850	7509	P110RY	17	GeoConn	2.41	2.52	Dry	2.56	Dry	2.56
BLM Min Safety Factor											1.125	1	1.6	1.6		

Non API casing spec sheets and casing design assumptions attached.

4. Cement

String	Lead/Tail	Top MD	Bottom MD	Quantity (sx)	Yield	Density	Cu Ft	Excess %	Cement Type	Additives
Surface	Tail	0	178	150	1.34	14.8	190	50%	Class C	Accelerator
Intermediate 1	Lead	0	640	100	1.88	12.9	180	50%	Class C	EconoCem-HLC + 5% Salt + 5% Kol-Seal
Intermediate 1	Tail	640	803	40	1.34	14.8	50	50%	Class C	Retarder
Intermediate 2	Lead	0	2560	240	1.88	12.9	450	50%	Class C	EconoCem-HLC + 5% Salt + 5% Kol-Seal
Intermediate 2	Tail	2560	3203	90	1.33	14.8	110	25%	Class C	Salt
Production	Lead	2703	8413	570	2.41	11.5	1360	40%	Class H	POZ, Extender, Fluid Loss, Dispersant, Retarder
Production	Tail	8413	16672	1040	1.73	12.5	1790	25%	Class H	POZ, Extender, Fluid Loss, Dispersant, Retarder

If losses are encountered while drilling intermediate 2 a stage tool will be added and cement will be adjusted accordingly.

5. Circulating Medium

Mud System Type: Closed

Will an air or gas system be used: No

Describe what will be on location to control well or mitigate other conditions: Sufficient quantities of mud materials will be on the well site at all times for the purpose of assuring well control and maintaining wellbore integrity. Surface interval will employ fresh water mud. The intermediate hole will utilize a saturated brine fluid to inhibit salt washout. The production hole will employ brine based and oil base fluid to inhibit formation reactivity and of the appropriate density to maintain well control.

Describe the mud monitoring system utilized: Centrifuge separation system. Open tank monitoring with EDR will be used for drilling fluids and return volumes. Open tank monitoring will be used for cement and cuttings return volumes. Mud properties will be monitored at least every 24 hours using industry accepted mud check practices.

Cuttings Volume: 6650 Cu Ft

Circulating Medium Table

Top Depth	Bottom Depth	Mud Type	Min Weight	Max Weight
0	178	Spud Mud	8.6	9.5
178	803	Salt Saturated	10	10
803	3203	Water Base Mud	8.6	9.5
3203	9163	Brine	9	10
9163	16672	OBM	9	10

6. Test, Logging, Coring

List of production tests including testing procedures, equipment and safety measures:

Will utilize MWD/LWD (Gamma Ray logging) from intermediate hole to TD of the well.

List of open and cased hole logs run in the well:

DIRECTIONAL SURVEY, GAMMA RAY LOG,

Coring operation description for the well:

N/A

7. Pressure

Anticipated Bottom Hole Pressure	4610	psi
Anticipated Surface Pressure	2655	psi
Anticipated Bottom Hole Temperature	145	°F
Anticipated Abnormal pressure, temp, or geo hazards	No	

8. Waste Management

Waste Type:	Drilling
Waste content description:	Fresh water based drilling fluid
Amount of waste:	1500 bbls
Waste disposal frequency:	Weekly (after drilling all surfaces)
Safe containment description:	Steel tanks with plastic-lined containment berms
Waste disposal type:	Haul to commercial facility
Disposal location ownership:	Commercial
Waste Type:	Grey Water & Human Waste
Waste content description:	Grey Water/Human Waste
Amount of waste:	5000 gallons
Waste disposal frequency:	Weekly
Safe containment description:	Approved waste storage tanks with containment
Waste disposal type:	Haul to commercial facility
Disposal location ownership:	Commercial
Waste Type:	Garbage
Waste content description:	General trash/garbage
Amount of waste:	5000 lbs
Waste disposal frequency:	Weekly
Safe containment description:	Enclosed trash trailer
Waste disposal type:	Haul to commercial facility
Disposal location ownership:	Commercial
Waste Type:	Drilling
Waste content description:	Drill Cuttings
Amount of waste:	6650 Cu Ft
Waste disposal frequency:	Per well
Safe containment description:	Steel tanks
Waste disposal type:	Haul to commercial facility
Disposal location ownership:	Commercial
Waste Type:	Drilling
Waste content description:	Brine water based drilling fluid
Amount of waste:	1500 bbls
Waste disposal frequency:	Monthly
Safe containment description:	Steel tanks with plastic-lined containment berms
Waste disposal type:	Haul to commercial facility
Disposal location ownership:	Commercial

9. Other Information

Well Plan and AC Report: attached
Batching Drilling Procedure: attached
WBD: attached
Flex Hose Specs: attached
Offline Cementing Procedure: attached
Break Testing Procedure: attached

5,000 psi BOP Schematic

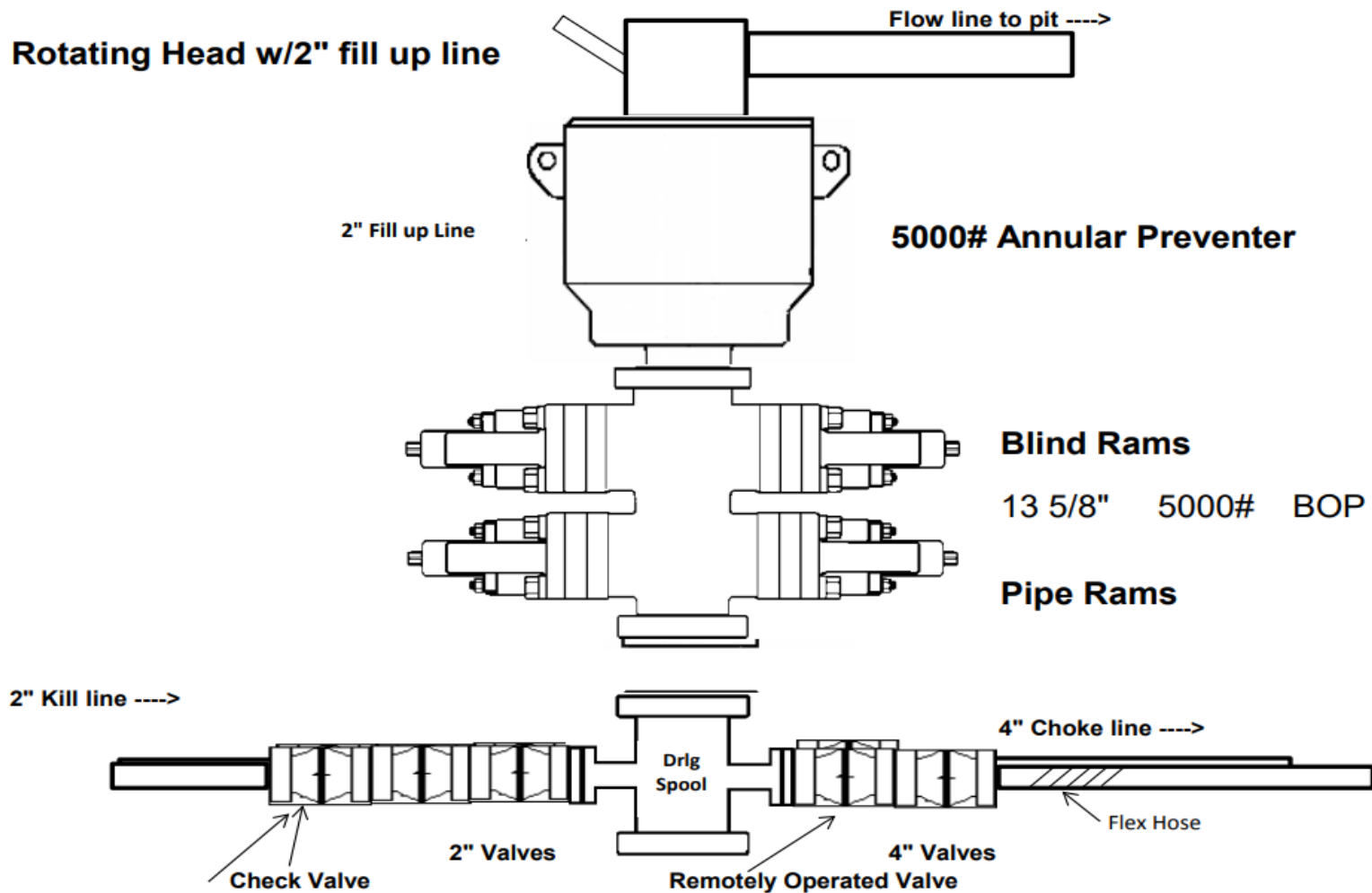

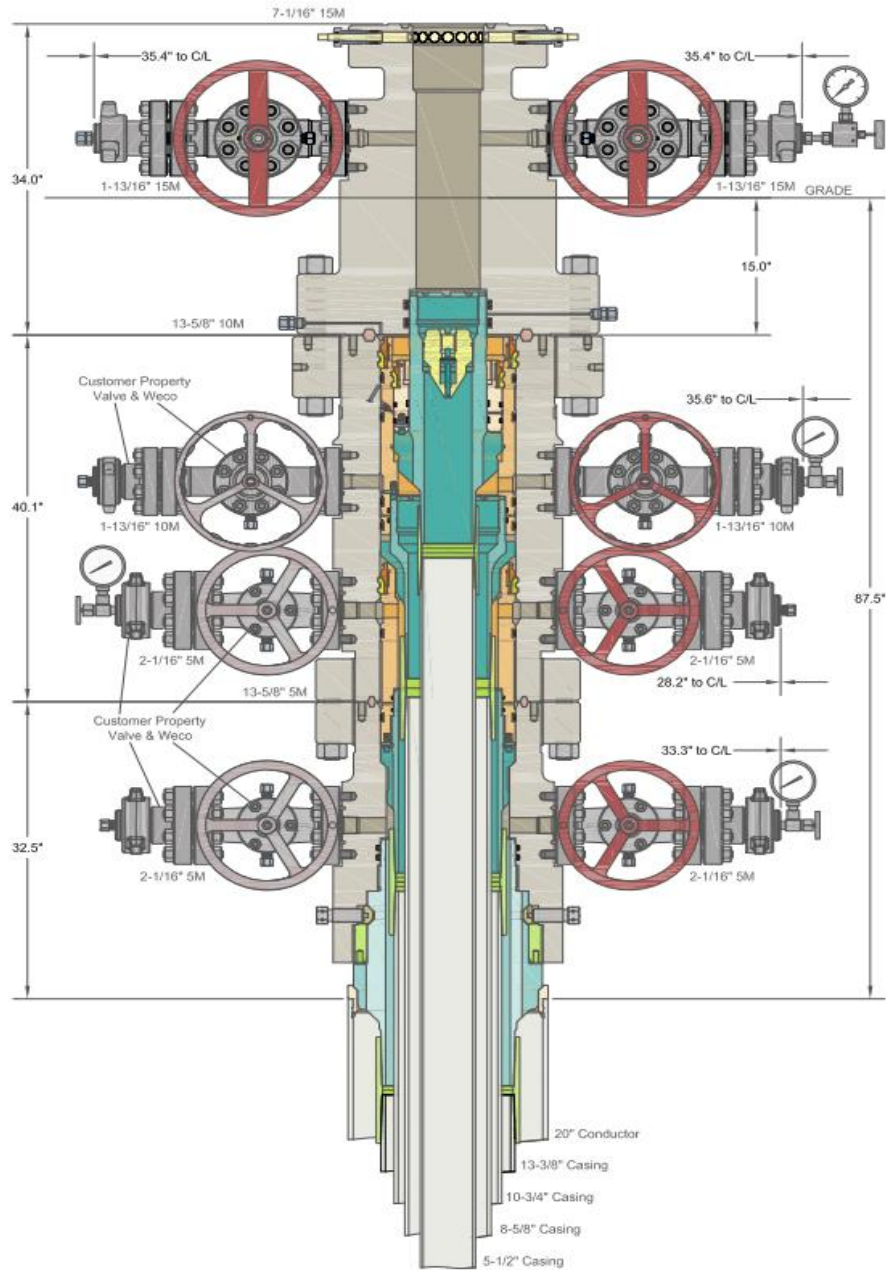

INFORMATION CONTAINED HEREIN IS THE PROPERTY OF CACTUS WELLHEAD, LLC. REPRODUCTION, DISCLOSURE, OR USE THEREOF IS PERMISSIBLE ONLY AS PROVIDED BY CONTRACT OR AS EXPRESSLY AUTHORIZED BY CACTUS WELLHEAD, LLC.

ALL DIMENSIONS APPROXIMATE

CACTUS WELLHEAD LLC

**PERMIAN RESOURCES
NEW MEXICO**

20" x 13-3/8" x 10-3/4" x 8-5/8" x 5-1/2" MBU-4T-CFL-R-DBLO Sys.
With 13-5/8" 10M x 7-1/16" 15M CTH-DBLHPS Tubing Head
And 10-3/4" & 7-5/8" & 5-1/2" Fluted Mandrel Casing Hangers

DRAWN	DLE	26OCT23
APPRV		
DRAWING NO.	HBE0001038	

Metal One Corp. Metal One	MO-FXL *1 Pipe Body: BMP P110HSCY MinYS125ksi Min95%WT Connection Data Sheet		CDS#	MO-FXL 8-5/8 32.0 P110HSCY MinYS125ksi Min95%WT	
			Date	8-Sep-21	

MO-FXL	Geometry		Imperial		S.I.	
	Pipe Body					
Grade *1	P110HSCY		P110HSCY			
MinYS *1	125	ksi	125	ksi		
Pipe OD (D)	8 5/8	in	219.08	mm		
Weight	32.00	lb/ft	47.68	kg/m		
Actual weight	31.10		46.34	kg/m		
Wall Thickness (t)	0.352	in	8.94	mm		
Pipe ID (d)	7.921	in	201.19	mm		
Pipe body cross section	9.149	in ²	5,902	mm ²		
Drift Dia.	7.796	in	198.02	mm		
-	-	-	-	-		

Connection						
Box OD (W)	8.625	in	219.08	mm		
PIN ID	7.921	in	201.19	mm		
Make up Loss	3.847	in	97.71	mm		
Box Critical Area	5.853	in ²	3686	mm ²		
Joint load efficiency	69	%	69	%		
Thread Taper	1 / 10 (1.2" per ft)					
Number of Threads	5 TPI					

Performance						
Performance Properties for Pipe Body						
S.M.Y.S. *1	1,144	kips	5,087	kN		
M.I.Y.P. *1	9,690	psi	66.83	MPa		
Collapse Strength *1	4,300	psi	29.66	MPa		

Note S.M.Y.S.= Specified Minimum YIELD Strength of Pipe body
M.I.Y.P. = Minimum Internal Yield Pressure of Pipe body
*1: BMP P110HSCY: MinYS125ksi, Min95%WT, Collapse Strength 4,300psi

Performance Properties for Connection						
Tensile Yield load	789 kips (69% of S.M.Y.S.)					
Min. Compression Yield	789 kips (69% of S.M.Y.S.)					
Internal Pressure	6,780 psi (70% of M.I.Y.P.)					
External Pressure	100% of Collapse Strength					
Max. DLS (deg. /100ft)	29					

Recommended Torque						
Min.	13,600	ft-lb	18,400	N-m		
Opti.	14,900	ft-lb	20,200	N-m		
Max.	16,200	ft-lb	21,900	N-m		
Operational Max.	28,400	ft-lb	38,500	N-m		

Note : Operational Max. torque can be applied for high torque application

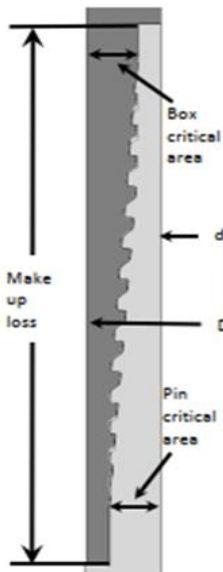

Metal One Corp. 	GEOCONN-SC	Page	MAI GC 5.5 20 SeAH PRY 95%RW
	Pipe Body: SeAH P110RY(SMYS110ksi) & 95%RBW *1	Date	SC-CplgOD 6.050 P110CY
	Coupling: P110CY (SMYS110ksi)	Rev.	29-Sep-21
	Connection Data Sheet		0

Geometry

Imperial

S.I.

Pipe Body

Grade *1	SeAH P110RY	-	SeAH P110RY	
SMYS	110	ksi	110	ksi
Pipe OD (D)	5.500	in	139.70	mm
Weight	20.00	lb/ft	29.80	kg/m
Wall Thickness (t)	0.361	in	9.17	mm
Pipe ID (d)	4.778	in	121.36	mm
Drift Dia.	4.653	in	118.19	mm

Connection

Coupling SMYS	110	ksi	110	ksi
Coupling OD (Wsc1)	6.050	in	153.67	mm
Coupling Length (NL)	8.350	in	212.09	mm
Make up Loss	4.125	in	104.78	mm
Pipe Critical Area	5.83	in ²	3,760	mm ²
Box Critical Area	6.00	in ²	3,874	mm ²
Thread Taper	1 / 16 (3/4" per ft)			
Number of Threads	5 TPI			

GEOCONN-SC

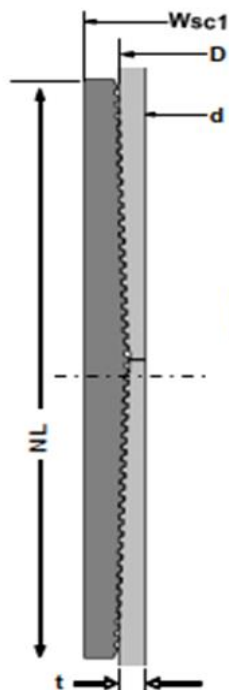

Performance

Imperial

S.I.

Performance Properties for Pipe Body

S.M.Y.S.	641	kips	2,852	kN
M.I.Y.P. *1	13,720	psi	94.62	MPa
Collapse Strength	11,100	psi	76.55	MPa

Note S.M.Y.S.= Specified Minimum YIELD Strength of Pipe body

M.I.Y.P. = Minimum Internal Yield Pressure of Pipe body

*1 Pipe: SeAH P110RY (SMYS110ksi), Min Wall Thickness of Pipe Body: 95% of Nom wall

Performance Properties for Connection

Min. Connection Joint Strength	100%	of S.M.Y.S.
Min. Compression Yield	100%	of S.M.Y.S.
Internal Pressure	100%	of M.I.Y.P.
External Pressure	100%	of Collapse Strength
Max. DLS (deg. /100ft)	>90	

Recommended Torque

Min.	14,600	ft-lb	19,700	N-m
Opti.	16,200	ft-lb	21,900	N-m
Max.	17,800	ft-lb	24,100	N-m
Operational Max.	19,500	ft-lb	26,400	N-m

Note : Operational Max. torque can be applied for high torque application

Legal Notice

The use of this information is at the reader/user's risk and no warranty is implied or expressed by Metal One Corporation or its parents, subsidiaries or affiliates (herein collectively referred to as "Metal One") with respect to the use of information contained herein. The information provided on this Connection Data Sheet is for informational purposes only, and was prepared by reference to engineering information that is specific to the subject products, without regard to safety-related factors, all of which are the sole responsibility of the operators and users of the subject connectors. Metal One assumes no responsibility for any errors with respect to this information.

Statements regarding the suitability of products for certain types of applications are based on Metal One's knowledge of typical requirements that are often placed on Metal One products in standard well configurations. Such statements are not binding statements about the suitability of products for a particular application. It is the customer's responsibility to validate that a particular product with the properties described in the product specification is suitable for use in a particular application.

The products described in this Connection Data Sheet are not recommended for use in deep water offshore applications. For more information, please refer to <http://www.m1o.com/ncr>. [www.m1o.com/images/tp/WebsiteTerms_Active_20233267_1.pdf](#) the contents of which are incorporated by reference into this Connection Data Sheet.

NEW MEXICO

(SP) EDDY

KANGAROO 12 FED

KANGAROO 12 FED COM 133H

OWB

Plan: PWP0

Standard Planning Report - Geographic

09 May, 2024

Planning Report - Geographic

Database:	Compass_17	Local Co-ordinate Reference	Well KANGAROO 12 FED COM 133H
Company:	NEW MEXICO	TVD Reference:	KB @ 3288.6ft
Project:	(SP) EDDY	MD Reference:	KB @ 3288.6ft
Site:	KANGAROO 12 FED	North Reference:	Grid
Well:	KANGAROO 12 FED COM 133H	Survey Calculation Method:	Minimum Curvature
Wellbore:	OWB		
Design:	PWP0		

Project	(SP) EDDY		
Map System:	US State Plane 1983	System Datum:	Mean Sea Level
Geo Datum:	North American Datum 1983		
Map Zone:	New Mexico Eastern Zone		

Site	KANGAROO 12 FED				
Site Position:		Northing:	183,906.42 m	Latitude:	32° 39' 31.109 N
From:	Map	Easting:	176,438.45 m	Longitude:	104° 12' 41.012 W
Position Uncertainty:	0.0 ft	Slot Radius:	13.200 in		

Well	KANGAROO 12 FED COM 133H					
Well Position	+N/-S	0.0 ft	Northing:	175,799.43 m	Latitude:	32° 35' 7.546 N
	+E/-W	0.0 ft	Easting:	183,907.07 m	Longitude:	104° 7' 54.969 W
Position Uncertainty		0.0 ft	Wellhead Elevation:	ft	Ground Level:	3,258.6 ft
Grid Convergence:		0.11 °				

Wellbore	OWB				
Magnetics	Model Name	Sample Date	Declination	Dip Angle	Field Strength
	IGRF200510	12/31/2009	(°)	(°)	(nT)
			8.03	60.48	48,949.32184448

Design	PWP0			
Audit Notes:				
Version:	Phase:	PROTOTYPE	Tie On Depth:	0.0
Vertical Section:	Depth From (TVD)	+N/-S	+E/-W	Direction
	(ft)	(ft)	(ft)	(°)
	0.0	0.0	0.0	270.18

Plan Survey Tool Program	Date	5/9/2024		
Depth From	Depth To	Survey (Wellbore)	Tool Name	Remarks
(ft)	(ft)			
1	0.0	16,672.6 PWP0 (OWB)	MWD	
			OWSG_Rev2_ MWD - Stand	

Plan Sections										
Measured	Inclination	Azimuth	Vertical	+N/-S	+E/-W	Dogleg	Build	Turn	TFO	Target
Depth	(°)	(°)	Depth	(ft)	(ft)	Rate	Rate	Rate	(°)	
(ft)			(ft)			(°/100ft)	(°/100ft)	(°/100ft)		
0.0	0.00	0.00	0.0	0.0	0.0	0.00	0.00	0.00	0.00	
2,000.0	0.00	0.00	2,000.0	0.0	0.0	0.00	0.00	0.00	0.00	
2,500.0	10.00	82.98	2,497.5	5.3	43.2	2.00	2.00	0.00	82.98	
4,864.5	10.00	82.98	4,826.0	55.5	450.7	0.00	0.00	0.00	0.00	
5,364.5	0.00	0.00	5,323.5	60.8	493.9	2.00	-2.00	0.00	180.00	
8,413.5	0.00	0.00	8,372.5	60.8	493.9	0.00	0.00	0.00	0.00	
9,163.5	90.00	269.73	8,850.0	58.5	16.4	12.00	12.00	-12.04	269.73	
16,672.6	90.00	269.73	8,850.0	23.3	-7,492.6	0.00	0.00	0.00	0.00	BHL-KANGAROO 12

Planning Report - Geographic

Database:	Compass_17	Local Co-ordinate Reference	Well KANGAROO 12 FED COM 133H
Company:	NEW MEXICO	TVD Reference:	KB @ 3288.6ft
Project:	(SP) EDDY	MD Reference:	KB @ 3288.6ft
Site:	KANGAROO 12 FED	North Reference:	Grid
Well:	KANGAROO 12 FED COM 133H	Survey Calculation Method:	Minimum Curvature
Wellbore:	OWB		
Design:	PWPO		

Planned Survey											
Measured Depth (ft)	Inclination (°)	Azimuth (°)	Vertical Depth (ft)	+N/-S (ft)	+E/-W (ft)	Map Northing (m)	Map Easting (m)	Latitude	Longitude		
0.0	0.00	0.00	0.0	0.0	0.0	175,799.43	183,907.07	32° 35' 7.546 N	104° 7' 54.969 W		
100.0	0.00	0.00	100.0	0.0	0.0	175,799.43	183,907.07	32° 35' 7.546 N	104° 7' 54.969 W		
200.0	0.00	0.00	200.0	0.0	0.0	175,799.43	183,907.07	32° 35' 7.546 N	104° 7' 54.969 W		
300.0	0.00	0.00	300.0	0.0	0.0	175,799.43	183,907.07	32° 35' 7.546 N	104° 7' 54.969 W		
400.0	0.00	0.00	400.0	0.0	0.0	175,799.43	183,907.07	32° 35' 7.546 N	104° 7' 54.969 W		
500.0	0.00	0.00	500.0	0.0	0.0	175,799.43	183,907.07	32° 35' 7.546 N	104° 7' 54.969 W		
600.0	0.00	0.00	600.0	0.0	0.0	175,799.43	183,907.07	32° 35' 7.546 N	104° 7' 54.969 W		
700.0	0.00	0.00	700.0	0.0	0.0	175,799.43	183,907.07	32° 35' 7.546 N	104° 7' 54.969 W		
800.0	0.00	0.00	800.0	0.0	0.0	175,799.43	183,907.07	32° 35' 7.546 N	104° 7' 54.969 W		
900.0	0.00	0.00	900.0	0.0	0.0	175,799.43	183,907.07	32° 35' 7.546 N	104° 7' 54.969 W		
1,000.0	0.00	0.00	1,000.0	0.0	0.0	175,799.43	183,907.07	32° 35' 7.546 N	104° 7' 54.969 W		
1,100.0	0.00	0.00	1,100.0	0.0	0.0	175,799.43	183,907.07	32° 35' 7.546 N	104° 7' 54.969 W		
1,200.0	0.00	0.00	1,200.0	0.0	0.0	175,799.43	183,907.07	32° 35' 7.546 N	104° 7' 54.969 W		
1,300.0	0.00	0.00	1,300.0	0.0	0.0	175,799.43	183,907.07	32° 35' 7.546 N	104° 7' 54.969 W		
1,400.0	0.00	0.00	1,400.0	0.0	0.0	175,799.43	183,907.07	32° 35' 7.546 N	104° 7' 54.969 W		
1,500.0	0.00	0.00	1,500.0	0.0	0.0	175,799.43	183,907.07	32° 35' 7.546 N	104° 7' 54.969 W		
1,600.0	0.00	0.00	1,600.0	0.0	0.0	175,799.43	183,907.07	32° 35' 7.546 N	104° 7' 54.969 W		
1,700.0	0.00	0.00	1,700.0	0.0	0.0	175,799.43	183,907.07	32° 35' 7.546 N	104° 7' 54.969 W		
1,800.0	0.00	0.00	1,800.0	0.0	0.0	175,799.43	183,907.07	32° 35' 7.546 N	104° 7' 54.969 W		
1,900.0	0.00	0.00	1,900.0	0.0	0.0	175,799.43	183,907.07	32° 35' 7.546 N	104° 7' 54.969 W		
2,000.0	0.00	0.00	2,000.0	0.0	0.0	175,799.43	183,907.07	32° 35' 7.546 N	104° 7' 54.969 W		
Start Build 2.00											
2,100.0	2.00	82.98	2,100.0	0.2	1.7	175,799.50	183,907.60	32° 35' 7.548 N	104° 7' 54.949 W		
2,200.0	4.00	82.98	2,199.8	0.9	6.9	175,799.69	183,909.18	32° 35' 7.554 N	104° 7' 54.888 W		
2,300.0	6.00	82.98	2,299.5	1.9	15.6	175,800.02	183,911.82	32° 35' 7.564 N	104° 7' 54.787 W		
2,400.0	8.00	82.98	2,398.7	3.4	27.7	175,800.47	183,915.51	32° 35' 7.579 N	104° 7' 54.646 W		
2,500.0	10.00	82.98	2,497.5	5.3	43.2	175,801.05	183,920.24	32° 35' 7.597 N	104° 7' 54.464 W		
Start 2364.5 hold at 2500.0 MD											
2,600.0	10.00	82.98	2,595.9	7.4	60.4	175,801.70	183,925.49	32° 35' 7.618 N	104° 7' 54.263 W		
2,700.0	10.00	82.98	2,694.4	9.6	77.7	175,802.34	183,930.74	32° 35' 7.639 N	104° 7' 54.061 W		
2,800.0	10.00	82.98	2,792.9	11.7	94.9	175,802.99	183,936.00	32° 35' 7.659 N	104° 7' 53.860 W		
2,900.0	10.00	82.98	2,891.4	13.8	112.1	175,803.64	183,941.25	32° 35' 7.680 N	104° 7' 53.658 W		
3,000.0	10.00	82.98	2,989.9	15.9	129.4	175,804.28	183,946.50	32° 35' 7.701 N	104° 7' 53.457 W		
3,100.0	10.00	82.98	3,088.4	18.0	146.6	175,804.93	183,951.76	32° 35' 7.721 N	104° 7' 53.255 W		
3,200.0	10.00	82.98	3,186.8	20.2	163.8	175,805.58	183,957.01	32° 35' 7.742 N	104° 7' 53.054 W		
3,300.0	10.00	82.98	3,285.3	22.3	181.1	175,806.22	183,962.26	32° 35' 7.763 N	104° 7' 52.852 W		
3,400.0	10.00	82.98	3,383.8	24.4	198.3	175,806.87	183,967.52	32° 35' 7.783 N	104° 7' 52.651 W		
3,500.0	10.00	82.98	3,482.3	26.5	215.5	175,807.52	183,972.77	32° 35' 7.804 N	104° 7' 52.449 W		
3,600.0	10.00	82.98	3,580.8	28.7	232.8	175,808.16	183,978.02	32° 35' 7.825 N	104° 7' 52.248 W		
3,700.0	10.00	82.98	3,679.2	30.8	250.0	175,808.81	183,983.28	32° 35' 7.845 N	104° 7' 52.046 W		
3,800.0	10.00	82.98	3,777.7	32.9	267.2	175,809.46	183,988.53	32° 35' 7.866 N	104° 7' 51.845 W		
3,900.0	10.00	82.98	3,876.2	35.0	284.5	175,810.10	183,993.78	32° 35' 7.887 N	104° 7' 51.643 W		
4,000.0	10.00	82.98	3,974.7	37.1	301.7	175,810.75	183,999.04	32° 35' 7.907 N	104° 7' 51.442 W		
4,100.0	10.00	82.98	4,073.2	39.3	319.0	175,811.40	184,004.29	32° 35' 7.928 N	104° 7' 51.240 W		
4,200.0	10.00	82.98	4,171.6	41.4	336.2	175,812.04	184,009.54	32° 35' 7.949 N	104° 7' 51.039 W		
4,300.0	10.00	82.98	4,270.1	43.5	353.4	175,812.69	184,014.80	32° 35' 7.969 N	104° 7' 50.837 W		
4,400.0	10.00	82.98	4,368.6	45.6	370.7	175,813.34	184,020.05	32° 35' 7.990 N	104° 7' 50.636 W		
4,500.0	10.00	82.98	4,467.1	47.7	387.9	175,813.98	184,025.30	32° 35' 8.011 N	104° 7' 50.434 W		
4,600.0	10.00	82.98	4,565.6	49.9	405.1	175,814.63	184,030.55	32° 35' 8.031 N	104° 7' 50.233 W		
4,700.0	10.00	82.98	4,664.0	52.0	422.4	175,815.28	184,035.81	32° 35' 8.052 N	104° 7' 50.031 W		
4,800.0	10.00	82.98	4,762.5	54.1	439.6	175,815.92	184,041.06	32° 35' 8.073 N	104° 7' 49.830 W		
4,864.5	10.00	82.98	4,826.0	55.5	450.7	175,816.34	184,044.45	32° 35' 8.086 N	104° 7' 49.700 W		
Start Drop -2.00											

Planning Report - Geographic

Database:	Compass_17	Local Co-ordinate Reference	Well KANGAROO 12 FED COM 133H
Company:	NEW MEXICO	TVD Reference:	KB @ 3288.6ft
Project:	(SP) EDDY	MD Reference:	KB @ 3288.6ft
Site:	KANGAROO 12 FED	North Reference:	Grid
Well:	KANGAROO 12 FED COM 133H	Survey Calculation Method:	Minimum Curvature
Wellbore:	OWB		
Design:	PWPO		

Planned Survey										
Measured Depth (ft)	Inclination (°)	Azimuth (°)	Vertical Depth (ft)	+N/-S (ft)	+E/-W (ft)	Map Northing (m)	Map Easting (m)	Latitude	Longitude	
4,900.0	9.29	82.98	4,861.0	56.2	456.6	175,816.56	184,046.25	32° 35' 8.093 N	104° 7' 49.631 W	
5,000.0	7.29	82.98	4,960.0	58.0	470.9	175,817.10	184,050.61	32° 35' 8.110 N	104° 7' 49.464 W	
5,100.0	5.29	82.98	5,059.4	59.3	481.8	175,817.51	184,053.92	32° 35' 8.123 N	104° 7' 49.336 W	
5,200.0	3.29	82.98	5,159.1	60.2	489.2	175,817.78	184,056.19	32° 35' 8.132 N	104° 7' 49.250 W	
5,300.0	1.29	82.98	5,259.0	60.7	493.2	175,817.93	184,057.39	32° 35' 8.137 N	104° 7' 49.203 W	
5,364.5	0.00	0.00	5,323.5	60.8	493.9	175,817.96	184,057.61	32° 35' 8.138 N	104° 7' 49.195 W	
Start 3049.0 hold at 5364.5 MD										
5,400.0	0.00	0.00	5,359.0	60.8	493.9	175,817.96	184,057.61	32° 35' 8.138 N	104° 7' 49.195 W	
5,500.0	0.00	0.00	5,459.0	60.8	493.9	175,817.96	184,057.61	32° 35' 8.138 N	104° 7' 49.195 W	
5,600.0	0.00	0.00	5,559.0	60.8	493.9	175,817.96	184,057.61	32° 35' 8.138 N	104° 7' 49.195 W	
5,700.0	0.00	0.00	5,659.0	60.8	493.9	175,817.96	184,057.61	32° 35' 8.138 N	104° 7' 49.195 W	
5,800.0	0.00	0.00	5,759.0	60.8	493.9	175,817.96	184,057.61	32° 35' 8.138 N	104° 7' 49.195 W	
5,900.0	0.00	0.00	5,859.0	60.8	493.9	175,817.96	184,057.61	32° 35' 8.138 N	104° 7' 49.195 W	
6,000.0	0.00	0.00	5,959.0	60.8	493.9	175,817.96	184,057.61	32° 35' 8.138 N	104° 7' 49.195 W	
6,100.0	0.00	0.00	6,059.0	60.8	493.9	175,817.96	184,057.61	32° 35' 8.138 N	104° 7' 49.195 W	
6,200.0	0.00	0.00	6,159.0	60.8	493.9	175,817.96	184,057.61	32° 35' 8.138 N	104° 7' 49.195 W	
6,300.0	0.00	0.00	6,259.0	60.8	493.9	175,817.96	184,057.61	32° 35' 8.138 N	104° 7' 49.195 W	
6,400.0	0.00	0.00	6,359.0	60.8	493.9	175,817.96	184,057.61	32° 35' 8.138 N	104° 7' 49.195 W	
6,500.0	0.00	0.00	6,459.0	60.8	493.9	175,817.96	184,057.61	32° 35' 8.138 N	104° 7' 49.195 W	
6,600.0	0.00	0.00	6,559.0	60.8	493.9	175,817.96	184,057.61	32° 35' 8.138 N	104° 7' 49.195 W	
6,700.0	0.00	0.00	6,659.0	60.8	493.9	175,817.96	184,057.61	32° 35' 8.138 N	104° 7' 49.195 W	
6,800.0	0.00	0.00	6,759.0	60.8	493.9	175,817.96	184,057.61	32° 35' 8.138 N	104° 7' 49.195 W	
6,900.0	0.00	0.00	6,859.0	60.8	493.9	175,817.96	184,057.61	32° 35' 8.138 N	104° 7' 49.195 W	
7,000.0	0.00	0.00	6,959.0	60.8	493.9	175,817.96	184,057.61	32° 35' 8.138 N	104° 7' 49.195 W	
7,100.0	0.00	0.00	7,059.0	60.8	493.9	175,817.96	184,057.61	32° 35' 8.138 N	104° 7' 49.195 W	
7,200.0	0.00	0.00	7,159.0	60.8	493.9	175,817.96	184,057.61	32° 35' 8.138 N	104° 7' 49.195 W	
7,300.0	0.00	0.00	7,259.0	60.8	493.9	175,817.96	184,057.61	32° 35' 8.138 N	104° 7' 49.195 W	
7,400.0	0.00	0.00	7,359.0	60.8	493.9	175,817.96	184,057.61	32° 35' 8.138 N	104° 7' 49.195 W	
7,500.0	0.00	0.00	7,459.0	60.8	493.9	175,817.96	184,057.61	32° 35' 8.138 N	104° 7' 49.195 W	
7,600.0	0.00	0.00	7,559.0	60.8	493.9	175,817.96	184,057.61	32° 35' 8.138 N	104° 7' 49.195 W	
7,700.0	0.00	0.00	7,659.0	60.8	493.9	175,817.96	184,057.61	32° 35' 8.138 N	104° 7' 49.195 W	
7,800.0	0.00	0.00	7,759.0	60.8	493.9	175,817.96	184,057.61	32° 35' 8.138 N	104° 7' 49.195 W	
7,900.0	0.00	0.00	7,859.0	60.8	493.9	175,817.96	184,057.61	32° 35' 8.138 N	104° 7' 49.195 W	
8,000.0	0.00	0.00	7,959.0	60.8	493.9	175,817.96	184,057.61	32° 35' 8.138 N	104° 7' 49.195 W	
8,100.0	0.00	0.00	8,059.0	60.8	493.9	175,817.96	184,057.61	32° 35' 8.138 N	104° 7' 49.195 W	
8,200.0	0.00	0.00	8,159.0	60.8	493.9	175,817.96	184,057.61	32° 35' 8.138 N	104° 7' 49.195 W	
8,300.0	0.00	0.00	8,259.0	60.8	493.9	175,817.96	184,057.61	32° 35' 8.138 N	104° 7' 49.195 W	
8,400.0	0.00	0.00	8,359.0	60.8	493.9	175,817.96	184,057.61	32° 35' 8.138 N	104° 7' 49.195 W	
8,413.5	0.00	0.00	8,372.5	60.8	493.9	175,817.96	184,057.61	32° 35' 8.138 N	104° 7' 49.195 W	
Start DLS 12.00 TFO 269.73										
8,425.0	1.38	269.73	8,384.0	60.8	493.8	175,817.96	184,057.57	32° 35' 8.138 N	104° 7' 49.196 W	
8,450.0	4.38	269.73	8,409.0	60.8	492.5	175,817.96	184,057.19	32° 35' 8.138 N	104° 7' 49.211 W	
8,475.0	7.38	269.73	8,433.8	60.8	489.9	175,817.95	184,056.41	32° 35' 8.138 N	104° 7' 49.241 W	
8,500.0	10.38	269.73	8,458.5	60.8	486.1	175,817.95	184,055.23	32° 35' 8.138 N	104° 7' 49.286 W	
8,525.0	13.38	269.73	8,483.0	60.7	480.9	175,817.94	184,053.66	32° 35' 8.138 N	104° 7' 49.346 W	
8,550.0	16.38	269.73	8,507.2	60.7	474.5	175,817.93	184,051.71	32° 35' 8.137 N	104° 7' 49.421 W	
8,575.0	19.38	269.73	8,530.9	60.7	466.8	175,817.92	184,049.37	32° 35' 8.137 N	104° 7' 49.511 W	
8,600.0	22.38	269.73	8,554.3	60.6	457.9	175,817.91	184,046.65	32° 35' 8.137 N	104° 7' 49.615 W	
8,625.0	25.38	269.73	8,577.2	60.6	447.8	175,817.89	184,043.57	32° 35' 8.137 N	104° 7' 49.733 W	
8,650.0	28.38	269.73	8,599.5	60.5	436.5	175,817.88	184,040.12	32° 35' 8.136 N	104° 7' 49.866 W	
8,675.0	31.38	269.73	8,621.1	60.5	424.1	175,817.86	184,036.33	32° 35' 8.136 N	104° 7' 50.011 W	
8,700.0	34.38	269.73	8,642.1	60.4	410.5	175,817.84	184,032.19	32° 35' 8.136 N	104° 7' 50.170 W	
8,725.0	37.38	269.73	8,662.4	60.3	395.8	175,817.82	184,027.73	32° 35' 8.135 N	104° 7' 50.341 W	

Planning Report - Geographic

Database:	Compass_17	Local Co-ordinate Reference	Well KANGAROO 12 FED COM 133H
Company:	NEW MEXICO	TVD Reference:	KB @ 3288.6ft
Project:	(SP) EDDY	MD Reference:	KB @ 3288.6ft
Site:	KANGAROO 12 FED	North Reference:	Grid
Well:	KANGAROO 12 FED COM 133H	Survey Calculation Method:	Minimum Curvature
Wellbore:	OWB		
Design:	PWPO		

Planned Survey										
Measured Depth (ft)	Inclination (°)	Azimuth (°)	Vertical Depth (ft)	+N/-S (ft)	+E/-W (ft)	Map Northing (m)	Map Easting (m)	Latitude	Longitude	
8,750.0	40.38	269.73	8,681.8	60.3	380.2	175,817.80	184,022.94	32° 35' 8.135 N	104° 7' 50.524 W	
8,775.0	43.38	269.73	8,700.5	60.2	363.5	175,817.77	184,017.86	32° 35' 8.134 N	104° 7' 50.719 W	
8,800.0	46.38	269.73	8,718.2	60.1	345.8	175,817.75	184,012.48	32° 35' 8.134 N	104° 7' 50.926 W	
8,825.0	49.38	269.73	8,734.9	60.0	327.3	175,817.72	184,006.83	32° 35' 8.133 N	104° 7' 51.142 W	
8,850.0	52.38	269.73	8,750.7	59.9	307.9	175,817.69	184,000.92	32° 35' 8.133 N	104° 7' 51.369 W	
8,875.0	55.38	269.73	8,765.4	59.8	287.7	175,817.66	183,994.77	32° 35' 8.132 N	104° 7' 51.605 W	
8,900.0	58.38	269.73	8,779.1	59.7	266.8	175,817.63	183,988.38	32° 35' 8.132 N	104° 7' 51.850 W	
8,925.0	61.38	269.73	8,791.6	59.6	245.2	175,817.60	183,981.79	32° 35' 8.131 N	104° 7' 52.102 W	
8,950.0	64.38	269.73	8,803.0	59.5	222.9	175,817.57	183,975.01	32° 35' 8.130 N	104° 7' 52.362 W	
8,975.0	67.38	269.73	8,813.3	59.4	200.1	175,817.54	183,968.06	32° 35' 8.130 N	104° 7' 52.629 W	
9,000.0	70.38	269.73	8,822.3	59.3	176.8	175,817.51	183,960.95	32° 35' 8.129 N	104° 7' 52.902 W	
9,025.0	73.38	269.73	8,830.0	59.2	153.0	175,817.47	183,953.71	32° 35' 8.128 N	104° 7' 53.179 W	
9,050.0	76.38	269.73	8,836.6	59.1	128.9	175,817.44	183,946.36	32° 35' 8.128 N	104° 7' 53.461 W	
9,075.0	79.38	269.73	8,841.8	59.0	104.4	175,817.40	183,938.91	32° 35' 8.127 N	104° 7' 53.747 W	
9,100.0	82.38	269.73	8,845.8	58.8	79.8	175,817.37	183,931.38	32° 35' 8.126 N	104° 7' 54.035 W	
9,125.0	85.38	269.73	8,848.4	58.7	54.9	175,817.33	183,923.81	32° 35' 8.126 N	104° 7' 54.326 W	
9,150.0	88.38	269.73	8,849.8	58.6	29.9	175,817.30	183,916.20	32° 35' 8.125 N	104° 7' 54.618 W	
9,163.5	90.00	269.73	8,850.0	58.5	16.4	175,817.28	183,912.09	32° 35' 8.125 N	104° 7' 54.775 W	
Start 7509.1 hold at 9163.5 MD										
9,200.0	90.00	269.73	8,850.0	58.4	-20.1	175,817.22	183,900.96	32° 35' 8.124 N	104° 7' 55.202 W	
9,300.0	90.00	269.73	8,850.0	57.9	-120.0	175,817.08	183,870.48	32° 35' 8.121 N	104° 7' 56.371 W	
9,400.0	90.00	269.73	8,850.0	57.4	-220.0	175,816.94	183,840.00	32° 35' 8.118 N	104° 7' 57.540 W	
9,500.0	90.00	269.73	8,850.0	57.0	-320.0	175,816.79	183,809.52	32° 35' 8.115 N	104° 7' 58.709 W	
9,600.0	90.00	269.73	8,850.0	56.5	-420.0	175,816.65	183,779.04	32° 35' 8.113 N	104° 7' 59.877 W	
9,700.0	90.00	269.73	8,850.0	56.0	-520.0	175,816.51	183,748.56	32° 35' 8.110 N	104° 8' 1.046 W	
9,800.0	90.00	269.73	8,850.0	55.6	-620.0	175,816.37	183,718.08	32° 35' 8.107 N	104° 8' 2.215 W	
9,900.0	90.00	269.73	8,850.0	55.1	-720.0	175,816.22	183,687.60	32° 35' 8.104 N	104° 8' 3.384 W	
10,000.0	90.00	269.73	8,850.0	54.6	-820.0	175,816.08	183,657.12	32° 35' 8.101 N	104° 8' 4.553 W	
10,100.0	90.00	269.73	8,850.0	54.1	-920.0	175,815.94	183,626.64	32° 35' 8.099 N	104° 8' 5.721 W	
10,200.0	90.00	269.73	8,850.0	53.7	-1,020.0	175,815.79	183,596.16	32° 35' 8.096 N	104° 8' 6.890 W	
10,300.0	90.00	269.73	8,850.0	53.2	-1,120.0	175,815.65	183,565.68	32° 35' 8.093 N	104° 8' 8.059 W	
10,400.0	90.00	269.73	8,850.0	52.7	-1,220.0	175,815.51	183,535.21	32° 35' 8.090 N	104° 8' 9.228 W	
10,500.0	90.00	269.73	8,850.0	52.3	-1,320.0	175,815.36	183,504.73	32° 35' 8.087 N	104° 8' 10.397 W	
10,600.0	90.00	269.73	8,850.0	51.8	-1,420.0	175,815.22	183,474.25	32° 35' 8.085 N	104° 8' 11.565 W	
10,700.0	90.00	269.73	8,850.0	51.3	-1,520.0	175,815.08	183,443.77	32° 35' 8.082 N	104° 8' 12.734 W	
10,800.0	90.00	269.73	8,850.0	50.9	-1,620.0	175,814.93	183,413.29	32° 35' 8.079 N	104° 8' 13.903 W	
10,900.0	90.00	269.73	8,850.0	50.4	-1,720.0	175,814.79	183,382.81	32° 35' 8.076 N	104° 8' 15.072 W	
11,000.0	90.00	269.73	8,850.0	49.9	-1,820.0	175,814.65	183,352.33	32° 35' 8.073 N	104° 8' 16.241 W	
11,100.0	90.00	269.73	8,850.0	49.5	-1,920.0	175,814.50	183,321.85	32° 35' 8.070 N	104° 8' 17.410 W	
11,200.0	90.00	269.73	8,850.0	49.0	-2,020.0	175,814.36	183,291.37	32° 35' 8.068 N	104° 8' 18.578 W	
11,300.0	90.00	269.73	8,850.0	48.5	-2,120.0	175,814.22	183,260.89	32° 35' 8.065 N	104° 8' 19.747 W	
11,400.0	90.00	269.73	8,850.0	48.0	-2,220.0	175,814.07	183,230.41	32° 35' 8.062 N	104° 8' 20.916 W	
11,500.0	90.00	269.73	8,850.0	47.6	-2,320.0	175,813.93	183,199.93	32° 35' 8.059 N	104° 8' 22.085 W	
11,600.0	90.00	269.73	8,850.0	47.1	-2,420.0	175,813.79	183,169.45	32° 35' 8.056 N	104° 8' 23.254 W	
11,700.0	90.00	269.73	8,850.0	46.6	-2,520.0	175,813.65	183,138.97	32° 35' 8.053 N	104° 8' 24.422 W	
11,800.0	90.00	269.73	8,850.0	46.2	-2,620.0	175,813.50	183,108.49	32° 35' 8.051 N	104° 8' 25.591 W	
11,900.0	90.00	269.73	8,850.0	45.7	-2,720.0	175,813.36	183,078.01	32° 35' 8.048 N	104° 8' 26.760 W	
12,000.0	90.00	269.73	8,850.0	45.2	-2,820.0	175,813.22	183,047.53	32° 35' 8.045 N	104° 8' 27.929 W	
12,100.0	90.00	269.73	8,850.0	44.8	-2,920.0	175,813.07	183,017.05	32° 35' 8.042 N	104° 8' 29.098 W	
12,200.0	90.00	269.73	8,850.0	44.3	-3,020.0	175,812.93	182,986.57	32° 35' 8.039 N	104° 8' 30.266 W	
12,300.0	90.00	269.73	8,850.0	43.8	-3,120.0	175,812.79	182,956.09	32° 35' 8.036 N	104° 8' 31.435 W	
12,400.0	90.00	269.73	8,850.0	43.3	-3,220.0	175,812.64	182,925.61	32° 35' 8.033 N	104° 8' 32.604 W	
12,500.0	90.00	269.73	8,850.0	42.9	-3,320.0	175,812.50	182,895.13	32° 35' 8.030 N	104° 8' 33.773 W	
12,600.0	90.00	269.73	8,850.0	42.4	-3,420.0	175,812.36	182,864.65	32° 35' 8.028 N	104° 8' 34.942 W	

Planning Report - Geographic

Database:	Compass_17	Local Co-ordinate Reference	Well KANGAROO 12 FED COM 133H
Company:	NEW MEXICO	TVD Reference:	KB @ 3288.6ft
Project:	(SP) EDDY	MD Reference:	KB @ 3288.6ft
Site:	KANGAROO 12 FED	North Reference:	Grid
Well:	KANGAROO 12 FED COM 133H	Survey Calculation Method:	Minimum Curvature
Wellbore:	OWB		
Design:	PWPO		

Planned Survey										
Measured Depth (ft)	Inclination (°)	Azimuth (°)	Vertical Depth (ft)	+N/-S (ft)	+E/-W (ft)	Map Northing (m)	Map Easting (m)	Latitude	Longitude	
12,700.0	90.00	269.73	8,850.0	41.9	-3,520.0	175,812.21	182,834.17	32° 35' 8.025 N	104° 8' 36.111 W	
12,787.0	90.00	269.73	8,850.0	41.5	-3,607.0	175,812.09	182,807.66	32° 35' 8.022 N	104° 8' 37.127 W	
NMNM 0559789 Entry at 12787.0 MD										
12,800.0	90.00	269.73	8,850.0	41.5	-3,620.0	175,812.07	182,803.69	32° 35' 8.022 N	104° 8' 37.279 W	
12,900.0	90.00	269.73	8,850.0	41.0	-3,720.0	175,811.93	182,773.21	32° 35' 8.019 N	104° 8' 38.448 W	
13,000.0	90.00	269.73	8,850.0	40.5	-3,820.0	175,811.78	182,742.73	32° 35' 8.016 N	104° 8' 39.617 W	
13,100.0	90.00	269.73	8,850.0	40.1	-3,920.0	175,811.64	182,712.25	32° 35' 8.013 N	104° 8' 40.786 W	
13,200.0	90.00	269.73	8,850.0	39.6	-4,020.0	175,811.50	182,681.77	32° 35' 8.010 N	104° 8' 41.955 W	
13,300.0	90.00	269.73	8,850.0	39.1	-4,120.0	175,811.35	182,651.29	32° 35' 8.007 N	104° 8' 43.123 W	
13,400.0	90.00	269.73	8,850.0	38.7	-4,220.0	175,811.21	182,620.82	32° 35' 8.004 N	104° 8' 44.292 W	
13,500.0	90.00	269.73	8,850.0	38.2	-4,320.0	175,811.07	182,590.34	32° 35' 8.002 N	104° 8' 45.461 W	
13,600.0	90.00	269.73	8,850.0	37.7	-4,420.0	175,810.93	182,559.86	32° 35' 7.999 N	104° 8' 46.630 W	
13,700.0	90.00	269.73	8,850.0	37.2	-4,520.0	175,810.78	182,529.38	32° 35' 7.996 N	104° 8' 47.799 W	
13,800.0	90.00	269.73	8,850.0	36.8	-4,620.0	175,810.64	182,498.90	32° 35' 7.993 N	104° 8' 48.967 W	
13,900.0	90.00	269.73	8,850.0	36.3	-4,720.0	175,810.50	182,468.42	32° 35' 7.990 N	104° 8' 50.136 W	
14,000.0	90.00	269.73	8,850.0	35.8	-4,820.0	175,810.35	182,437.94	32° 35' 7.987 N	104° 8' 51.305 W	
14,100.0	90.00	269.73	8,850.0	35.4	-4,920.0	175,810.21	182,407.46	32° 35' 7.984 N	104° 8' 52.474 W	
14,115.0	90.00	269.73	8,850.0	35.3	-4,935.0	175,810.19	182,402.89	32° 35' 7.984 N	104° 8' 52.649 W	
NMNM 015003 Entry at 14115.0 MD										
14,200.0	90.00	269.73	8,850.0	34.9	-5,020.0	175,810.07	182,376.98	32° 35' 7.981 N	104° 8' 53.643 W	
14,300.0	90.00	269.73	8,850.0	34.4	-5,120.0	175,809.92	182,346.50	32° 35' 7.978 N	104° 8' 54.812 W	
14,400.0	90.00	269.73	8,850.0	34.0	-5,220.0	175,809.78	182,316.02	32° 35' 7.975 N	104° 8' 55.980 W	
14,500.0	90.00	269.73	8,850.0	33.5	-5,320.0	175,809.64	182,285.54	32° 35' 7.972 N	104° 8' 57.149 W	
14,600.0	90.00	269.73	8,850.0	33.0	-5,420.0	175,809.49	182,255.06	32° 35' 7.969 N	104° 8' 58.318 W	
14,700.0	90.00	269.73	8,850.0	32.5	-5,520.0	175,809.35	182,224.58	32° 35' 7.967 N	104° 8' 59.487 W	
14,800.0	90.00	269.73	8,850.0	32.1	-5,620.0	175,809.21	182,194.10	32° 35' 7.964 N	104° 9' 0.656 W	
14,900.0	90.00	269.73	8,850.0	31.6	-5,720.0	175,809.06	182,163.62	32° 35' 7.961 N	104° 9' 1.824 W	
15,000.0	90.00	269.73	8,850.0	31.1	-5,820.0	175,808.92	182,133.14	32° 35' 7.958 N	104° 9' 2.993 W	
15,100.0	90.00	269.73	8,850.0	30.7	-5,920.0	175,808.78	182,102.66	32° 35' 7.955 N	104° 9' 4.162 W	
15,200.0	90.00	269.73	8,850.0	30.2	-6,020.0	175,808.63	182,072.18	32° 35' 7.952 N	104° 9' 5.331 W	
15,300.0	90.00	269.73	8,850.0	29.7	-6,120.0	175,808.49	182,041.70	32° 35' 7.949 N	104° 9' 6.500 W	
15,400.0	90.00	269.73	8,850.0	29.3	-6,220.0	175,808.35	182,011.22	32° 35' 7.946 N	104° 9' 7.668 W	
15,500.0	90.00	269.73	8,850.0	28.8	-6,320.0	175,808.21	181,980.74	32° 35' 7.943 N	104° 9' 8.837 W	
15,600.0	90.00	269.73	8,850.0	28.3	-6,420.0	175,808.06	181,950.26	32° 35' 7.940 N	104° 9' 10.006 W	
15,700.0	90.00	269.73	8,850.0	27.8	-6,520.0	175,807.92	181,919.78	32° 35' 7.937 N	104° 9' 11.175 W	
15,800.0	90.00	269.73	8,850.0	27.4	-6,620.0	175,807.78	181,889.30	32° 35' 7.934 N	104° 9' 12.344 W	
15,900.0	90.00	269.73	8,850.0	26.9	-6,720.0	175,807.63	181,858.82	32° 35' 7.931 N	104° 9' 13.513 W	
16,000.0	90.00	269.73	8,850.0	26.4	-6,820.0	175,807.49	181,828.34	32° 35' 7.928 N	104° 9' 14.681 W	
16,100.0	90.00	269.73	8,850.0	26.0	-6,920.0	175,807.35	181,797.86	32° 35' 7.925 N	104° 9' 15.850 W	
16,200.0	90.00	269.73	8,850.0	25.5	-7,020.0	175,807.20	181,767.38	32° 35' 7.922 N	104° 9' 17.019 W	
16,300.0	90.00	269.73	8,850.0	25.0	-7,120.0	175,807.06	181,736.90	32° 35' 7.919 N	104° 9' 18.188 W	
16,400.0	90.00	269.73	8,850.0	24.6	-7,220.0	175,806.92	181,706.43	32° 35' 7.916 N	104° 9' 19.357 W	
16,500.0	90.00	269.73	8,850.0	24.1	-7,320.0	175,806.77	181,675.95	32° 35' 7.913 N	104° 9' 20.525 W	
16,600.0	90.00	269.73	8,850.0	23.6	-7,420.0	175,806.63	181,645.47	32° 35' 7.910 N	104° 9' 21.694 W	
16,672.6	90.00	269.73	8,850.0	23.3	-7,492.6	175,806.53	181,623.34	32° 35' 7.908 N	104° 9' 22.543 W	
TD at 16672.6										

Planning Report - Geographic

Database:	Compass_17	Local Co-ordinate Reference	Well KANGAROO 12 FED COM 133H
Company:	NEW MEXICO	TVD Reference:	KB @ 3288.6ft
Project:	(SP) EDDY	MD Reference:	KB @ 3288.6ft
Site:	KANGAROO 12 FED	North Reference:	Grid
Well:	KANGAROO 12 FED COM 133H	Survey Calculation Method:	Minimum Curvature
Wellbore:	OWB		
Design:	PWPO		

Design Targets									
Target Name	Dip Angle	Dip Dir.	TVD	+N/-S	+E/-W	Northing	Easting	Latitude	Longitude
- hit/miss target	(°)	(°)	(ft)	(ft)	(ft)	(m)	(m)		
- Shape									
BHL-KANGAROO 12 FE - plan hits target center - Point	0.00	0.00	8,850.0	23.3	-7,492.6	175,806.53	181,623.33	32° 35' 7.908 N	104° 9' 22.543 W
FTP-KANGAROO 12 FE - plan misses target center by 61.0ft at 8936.8ft MD (8797.2 TVD, 59.6 N, 234.7 E) - Point	0.00	0.00	8,850.0	45.9	261.9	175,813.42	183,986.90	32° 35' 7.995 N	104° 7' 51.907 W

Plan Annotations					
Measured Depth	Vertical Depth	Local Coordinates		Comment	
(ft)	(ft)	+N/-S (ft)	+E/-W (ft)		
2,000.0	2,000.0	0.0	0.0	Start Build 2.00	
2,500.0	2,497.5	5.3	43.2	Start 2364.5 hold at 2500.0 MD	
4,864.5	4,826.0	55.5	450.7	Start Drop -2.00	
5,364.5	5,323.5	60.8	493.9	Start 3049.0 hold at 5364.5 MD	
8,413.5	8,372.5	60.8	493.9	Start DLS 12.00 TFO 269.73	
9,163.5	8,850.0	60.3	390.9	Start 7509.1 hold at 9163.5 MD	
12,787.0	8,850.0	58.5	16.4	NMNM 0559789 Entry at 12787.0 MD	
14,115.0	8,850.0	41.5	-3,607.0	NMNM 015003 Entry at 14115.0 MD	
16,672.6	8,850.0	35.3	-4,935.0	TD at 16672.6	

NEW MEXICO

(SP) EDDY

KANGAROO 12 FED

KANGAROO 12 FED COM 133H

OWB

PWP0

Anticollision Report

09 May, 2024

Anticollision Report

Company:	NEW MEXICO	Local Co-ordinate Reference	Well KANGAROO 12 FED COM 133H
Project:	(SP) EDDY	TVD Reference:	KB @ 3288.6ft
Reference Site:	KANGAROO 12 FED	MD Reference:	KB @ 3288.6ft
Site Error:	0.0 ft	North Reference:	Grid
Reference Well:	KANGAROO 12 FED COM 133H	Survey Calculation Method:	Minimum Curvature
Well Error:	0.0 ft	Output errors are at	2.00 sigma
Reference Wellbore	OWB	Database:	Compass_17
Reference Design:	PWP0	Offset TVD Reference:	Offset Datum

Reference	PWP0		
Filter type:	NO GLOBAL FILTER: Using user defined selection & filtering criteria		
Interpolation Method	Stations	Error Model:	ISCWSA
Depth Range:	Unlimited	Scan Method:	Closest Approach 3D
Results Limited by:	Maximum centre distance of 1,000.0ft	Error Surface:	Pedal Curve
Warning Levels Evaluated at:	2.00 Sigma	Casing Method:	Not applied

Survey Tool Program	Date	5/9/2024		
From (ft)	To (ft)	Survey (Wellbore)	Tool Name	Description
0.0	16,672.6	PWP0 (OWB)	MWD	OWSG_Rev2_MWD - Standard

Summary						
Site Name	Reference Measure	Offset Measure	Distance Between Centres (ft)	Distance Between Ellipses (ft)	Separation	Warning
Offset Well - Wellbore - Design						
KANGAROO 12 FED						
KANGAROO 12 FED COM 121H - OWB - PWP0						Out of range
KANGAROO 12 FED COM 122H - OWB - PWP0						Out of range
KANGAROO 12 FED COM 123H - OWB - PWP0	2,009.0	2,010.6	132.0	117.8	9.298	CC
KANGAROO 12 FED COM 123H - OWB - PWP0	2,200.0	2,209.3	132.7	117.2	8.547	ES
KANGAROO 12 FED COM 123H - OWB - PWP0	7,300.0	7,314.5	324.1	269.3	5.915	SF
KANGAROO 12 FED COM 124H - OWB - PWP0	2,000.0	2,001.0	165.0	150.8	11.677	CC
KANGAROO 12 FED COM 124H - OWB - PWP0	2,004.5	2,005.7	165.0	150.8	11.651	ES
KANGAROO 12 FED COM 124H - OWB - PWP0	2,400.0	2,410.4	180.4	163.6	10.700	SF
KANGAROO 12 FED COM 131H - OWB - PWP0						Out of range
KANGAROO 12 FED COM 132H - OWB - PWP0						Out of range
KANGAROO 12 FED COM 134H - OWB - PWP0	2,038.0	2,038.7	32.2	17.8	2.239	CC, ES
KANGAROO 12 FED COM 134H - OWB - PWP0	2,100.0	2,100.7	32.8	18.1	2.222	SF
KANGAROO 12 FED COM 201H - OWB - PWP0						Out of range
KANGAROO 12 FED COM 202H - OWB - PWP0						Out of range
KANGAROO 12 FED COM 203H - OWB - PWP0	2,000.0	2,000.4	66.0	51.9	4.671	CC
KANGAROO 12 FED COM 203H - OWB - PWP0	2,004.5	2,005.0	66.0	51.8	4.661	ES
KANGAROO 12 FED COM 203H - OWB - PWP0	16,672.6	16,921.8	719.9	373.0	2.075	SF
KANGAROO 12 FED COM 204H - OWB - PWP0	2,000.0	2,000.8	99.0	84.9	7.007	CC
KANGAROO 12 FED COM 204H - OWB - PWP0	2,004.5	2,005.4	99.0	84.8	6.991	ES
KANGAROO 12 FED COM 204H - OWB - PWP0	16,672.6	16,822.5	733.6	385.9	2.110	SF

Offset Design	KANGAROO 12 FED - KANGAROO 12 FED COM 123H - OWB - PWP0											Offset Site Error:	0.0 ft
Survey Program:	0-MWD											Offset Well Error:	0.0 ft
Reference	Vertical	Offset	Semi Major Axis	Reference	Offset	Highside	Offset Wellbore Centre	Distance	Minimum	Separation	Warning		
Measured Depth (ft)	Depth (ft)	Measured Depth (ft)	Vertical Depth (ft)	(ft)	(ft)	Toolface (°)	+N/-S (ft)	+E/-W (ft)	Between Centres (ft)	Between Ellipses (ft)	Factor		
0.0	0.0	1.2	1.2	0.0	0.0	-90.12	-0.3	-132.0	132.0				
100.0	100.0	101.2	101.2	0.3	0.3	-90.12	-0.3	-132.0	132.0	131.5	260.728		
200.0	200.0	201.2	201.2	0.6	0.6	-90.12	-0.3	-132.0	132.0	130.7	107.898		
300.0	300.0	301.2	301.2	1.0	1.0	-90.12	-0.3	-132.0	132.0	130.0	68.024		
400.0	400.0	401.2	401.2	1.3	1.3	-90.12	-0.3	-132.0	132.0	129.3	49.669		
500.0	500.0	501.2	501.2	1.7	1.7	-90.12	-0.3	-132.0	132.0	128.6	39.115		

CC - Min centre to center distance or convergent point, SF - min separation factor, ES - min ellipse separation

Anticollision Report

Company:	NEW MEXICO	Local Co-ordinate Reference	Well KANGAROO 12 FED COM 133H
Project:	(SP) EDDY	TVD Reference:	KB @ 3288.6ft
Reference Site:	KANGAROO 12 FED	MD Reference:	KB @ 3288.6ft
Site Error:	0.0 ft	North Reference:	Grid
Reference Well:	KANGAROO 12 FED COM 133H	Survey Calculation Method:	Minimum Curvature
Well Error:	0.0 ft	Output errors are at	2.00 sigma
Reference Wellbore	OWB	Database:	Compass_17
Reference Design:	PWP0	Offset TVD Reference:	Offset Datum

Offset Design KANGAROO 12 FED - KANGAROO 12 FED COM 123H - OWB - PWP0													Offset Site Error:	0.0 ft
Survey Program: 0-MWD													Offset Well Error:	0.0 ft
Measured Depth (ft)	Vertical Depth (ft)	Offset		Semi Major Axis		Highside Toolface (°)	Offset Wellbore Centre		Distance		Minimum Separation (ft)	Separation Factor	Warning	
		Measured Depth (ft)	Vertical Depth (ft)	Reference (ft)	Offset (ft)		+N/-S	+E/-W (ft)	Between Centres (ft)	Between Ellipses (ft)				
600.0	600.0	601.2	601.2	2.0	2.0	-90.12	-0.3	-132.0	132.0	127.9	4.09	32.260		
700.0	700.0	701.2	701.2	2.4	2.4	-90.12	-0.3	-132.0	132.0	127.2	4.81	27.449		
800.0	800.0	801.2	801.2	2.8	2.8	-90.12	-0.3	-132.0	132.0	126.4	5.52	23.887		
900.0	900.0	901.2	901.2	3.1	3.1	-90.12	-0.3	-132.0	132.0	125.7	6.24	21.143		
1,000.0	1,000.0	1,001.2	1,001.2	3.5	3.5	-90.12	-0.3	-132.0	132.0	125.0	6.96	18.965		
1,100.0	1,100.0	1,101.2	1,101.2	3.8	3.8	-90.12	-0.3	-132.0	132.0	124.3	7.68	17.194		
1,200.0	1,200.0	1,201.2	1,201.2	4.2	4.2	-90.12	-0.3	-132.0	132.0	123.6	8.39	15.725		
1,300.0	1,300.0	1,301.2	1,301.2	4.6	4.6	-90.12	-0.3	-132.0	132.0	122.9	9.11	14.487		
1,400.0	1,400.0	1,401.2	1,401.2	4.9	4.9	-90.12	-0.3	-132.0	132.0	122.1	9.83	13.430		
1,500.0	1,500.0	1,501.2	1,501.2	5.3	5.3	-90.12	-0.3	-132.0	132.0	121.4	10.54	12.517		
1,600.0	1,600.0	1,601.2	1,601.2	5.6	5.6	-90.12	-0.3	-132.0	132.0	120.7	11.26	11.720		
1,700.0	1,700.0	1,701.2	1,701.2	6.0	6.0	-90.12	-0.3	-132.0	132.0	120.0	11.98	11.018		
1,800.0	1,800.0	1,801.2	1,801.2	6.3	6.3	-90.12	-0.3	-132.0	132.0	119.3	12.69	10.396		
1,900.0	1,900.0	1,901.2	1,901.2	6.7	6.7	-90.12	-0.3	-132.0	132.0	118.6	13.41	9.840		
2,000.0	2,000.0	2,001.3	2,001.3	7.1	7.1	-90.12	-0.3	-132.0	132.0	117.8	14.13	9.341		
2,009.0	2,009.0	2,010.6	2,010.6	7.1	7.1	-173.10	-0.3	-132.0	132.0	117.8	14.19	9.298 CC		
2,100.0	2,100.0	2,105.3	2,105.3	7.4	7.4	-172.74	0.8	-130.3	132.1	117.3	14.84	8.904		
2,200.0	2,199.8	2,209.3	2,209.1	7.8	7.8	-171.70	3.9	-125.5	132.7	117.2	15.53	8.547 ES		
2,300.0	2,299.5	2,313.2	2,312.5	8.1	8.2	-169.99	9.0	-117.6	133.9	117.7	16.21	8.258		
2,400.0	2,398.7	2,416.9	2,415.4	8.5	8.5	-167.66	16.1	-106.5	135.7	118.8	16.89	8.033		
2,500.0	2,497.5	2,519.7	2,516.9	8.8	8.9	-164.81	25.1	-92.5	138.3	120.7	17.57	7.872		
2,600.0	2,595.9	2,619.4	2,615.1	9.2	9.3	-162.07	34.5	-77.9	142.1	123.8	18.29	7.768		
2,700.0	2,694.4	2,719.1	2,713.3	9.6	9.7	-159.47	43.8	-63.3	146.2	127.1	19.02	7.684		
2,800.0	2,792.9	2,818.8	2,811.5	10.0	10.1	-157.01	53.2	-48.8	150.5	130.8	19.76	7.618		
2,900.0	2,891.4	2,918.5	2,909.7	10.4	10.4	-154.70	62.5	-34.2	155.2	134.7	20.51	7.565		
3,000.0	2,989.9	3,018.3	3,007.8	10.7	10.8	-152.53	71.9	-19.6	160.0	138.8	21.27	7.524		
3,100.0	3,088.4	3,118.0	3,106.0	11.1	11.2	-150.48	81.2	-5.1	165.1	143.1	22.04	7.493		
3,200.0	3,186.8	3,217.7	3,204.2	11.6	11.6	-148.56	90.6	9.5	170.4	147.6	22.82	7.469		
3,300.0	3,285.3	3,317.4	3,302.4	12.0	12.1	-146.76	99.9	24.1	175.9	152.3	23.60	7.452		
3,400.0	3,383.8	3,417.1	3,400.6	12.4	12.5	-145.07	109.3	38.6	181.5	157.1	24.40	7.440		
3,500.0	3,482.3	3,516.8	3,498.8	12.8	12.9	-143.48	118.7	53.2	187.3	162.1	25.20	7.433		
3,600.0	3,580.8	3,616.5	3,597.0	13.2	13.3	-141.98	128.0	67.8	193.2	167.2	26.00	7.430		
3,700.0	3,679.2	3,716.2	3,695.2	13.6	13.7	-140.58	137.4	82.3	199.2	172.4	26.82	7.430		
3,800.0	3,777.7	3,815.9	3,793.3	14.0	14.1	-139.26	146.7	96.9	205.4	177.7	27.64	7.432		
3,900.0	3,876.2	3,915.6	3,891.5	14.5	14.5	-138.01	156.1	111.5	211.6	183.2	28.46	7.436		
4,000.0	3,974.7	4,015.3	3,989.7	14.9	15.0	-136.84	165.4	126.0	218.0	188.7	29.29	7.442		
4,100.0	4,073.2	4,115.0	4,087.9	15.3	15.4	-135.73	174.8	140.6	224.4	194.3	30.12	7.450		
4,200.0	4,171.6	4,214.7	4,186.1	15.7	15.8	-134.69	184.2	155.2	230.9	200.0	30.96	7.458		
4,300.0	4,270.1	4,314.4	4,284.3	16.2	16.2	-133.70	193.5	169.7	237.5	205.7	31.80	7.468		
4,400.0	4,368.6	4,414.1	4,382.5	16.6	16.7	-132.77	202.9	184.3	244.1	211.5	32.65	7.478		
4,500.0	4,467.1	4,513.8	4,480.7	17.0	17.1	-131.89	212.2	198.9	250.9	217.4	33.50	7.489		
4,600.0	4,565.6	4,613.5	4,578.8	17.5	17.5	-131.05	221.6	213.4	257.6	223.3	34.35	7.500		
4,700.0	4,664.0	4,713.2	4,677.0	17.9	17.9	-130.25	230.9	228.0	264.4	229.2	35.20	7.512		
4,800.0	4,762.5	4,812.9	4,775.2	18.3	18.4	-129.50	240.3	242.6	271.3	235.3	36.06	7.524		
4,864.5	4,826.0	4,877.1	4,838.5	18.6	18.7	-129.03	246.3	252.0	275.8	239.1	36.61	7.532		
4,900.0	4,861.0	4,912.6	4,873.4	18.8	18.8	-128.78	249.6	257.2	278.1	241.2	36.92	7.532		
5,000.0	4,960.0	5,012.3	4,971.6	19.2	19.2	-127.71	259.0	271.7	283.2	245.4	37.78	7.496		
5,100.0	5,059.4	5,111.9	5,069.7	19.6	19.7	-126.09	268.3	286.3	286.4	247.7	38.65	7.409		
5,200.0	5,159.1	5,211.3	5,167.5	19.9	20.1	-123.92	277.7	300.8	287.8	248.3	39.52	7.283		
5,300.0	5,259.0	5,310.3	5,265.1	20.3	20.5	-121.18	287.0	315.3	287.9	247.5	40.38	7.129		
5,364.5	5,323.5	5,373.9	5,327.7	20.5	20.8	-36.11	292.9	324.5	287.4	246.4	40.93	7.020		

CC - Min centre to center distance or convergent point, SF - min separation factor, ES - min ellipse separation

Anticollision Report

Company:	NEW MEXICO	Local Co-ordinate Reference	Well KANGAROO 12 FED COM 133H
Project:	(SP) EDDY	TVD Reference:	KB @ 3288.6ft
Reference Site:	KANGAROO 12 FED	MD Reference:	KB @ 3288.6ft
Site Error:	0.0 ft	North Reference:	Grid
Reference Well:	KANGAROO 12 FED COM 133H	Survey Calculation Method:	Minimum Curvature
Well Error:	0.0 ft	Output errors are at	2.00 sigma
Reference Wellbore	OWB	Database:	Compass_17
Reference Design:	PWP0	Offset TVD Reference:	Offset Datum

Offset Design KANGAROO 12 FED - KANGAROO 12 FED COM 123H - OWB - PWP0													Offset Site Error:	0.0 ft
Survey Program: 0-MWD													Offset Well Error:	0.0 ft
Measured Depth (ft)	Vertical Depth (ft)	Offset		Semi Major Axis		Highside Toolface (°)	Offset Wellbore Centre		Distance		Minimum Separation (ft)	Separation Factor	Warning	
		Measured Depth (ft)	Vertical Depth (ft)	Reference (ft)	Offset (ft)		+N/-S (ft)	+E/-W (ft)	Between Centres (ft)	Between Ellipses (ft)				
5,400.0	5,359.0	5,408.9	5,362.1	20.6	21.0	-34.90	296.2	329.7	287.1	245.8	41.23	6.962		
5,464.1	5,423.2	5,472.0	5,424.4	20.8	21.2	-32.71	302.1	338.9	286.8	245.1	41.77	6.867		
5,500.0	5,459.0	5,507.4	5,459.1	21.0	21.4	-31.49	305.5	344.1	286.9	244.8	42.07	6.820		
5,600.0	5,559.0	5,605.8	5,556.1	21.3	21.8	-28.08	314.7	358.4	287.8	244.9	42.89	6.711		
5,700.0	5,659.0	5,704.3	5,653.1	21.6	22.3	-24.71	323.9	372.8	289.8	246.1	43.68	6.633		
5,800.0	5,759.0	5,802.8	5,750.1	21.9	22.7	-21.39	333.2	387.2	292.7	248.2	44.46	6.583		
5,900.0	5,859.0	5,901.3	5,847.1	22.3	23.1	-18.14	342.4	401.6	296.7	251.4	45.22	6.561		
6,000.0	5,959.0	5,999.8	5,944.1	22.6	23.6	-14.99	351.7	416.0	301.6	255.6	45.95	6.562		
6,100.0	6,059.0	6,098.9	6,041.7	22.9	24.0	-11.94	360.9	430.4	307.3	260.7	46.67	6.585		
6,200.0	6,159.0	6,202.0	6,143.6	23.3	24.4	-9.28	369.3	443.5	313.1	265.6	47.41	6.603		
6,300.0	6,259.0	6,306.1	6,247.0	23.6	24.8	-7.31	375.8	453.5	317.8	269.7	48.12	6.604		
6,400.0	6,359.0	6,410.9	6,351.5	23.9	25.2	-5.99	380.2	460.4	321.3	272.4	48.82	6.580		
6,500.0	6,459.0	6,516.3	6,456.8	24.3	25.6	-5.29	382.5	464.1	323.2	273.7	49.50	6.528		
6,600.0	6,559.0	6,619.7	6,560.2	24.6	25.9	-5.17	383.0	464.7	323.5	273.3	50.16	6.449		
6,700.0	6,659.0	6,719.7	6,660.2	24.9	26.3	-5.17	383.0	464.7	323.5	272.7	50.82	6.365		
6,800.0	6,759.0	6,819.7	6,760.2	25.3	26.6	-5.17	383.0	464.7	323.5	272.0	51.49	6.283		
6,900.0	6,859.0	6,919.7	6,860.2	25.6	26.9	-5.17	383.0	464.7	323.5	271.3	52.15	6.203		
7,000.0	6,959.0	7,019.7	6,960.2	25.9	27.2	-5.17	383.0	464.7	323.5	270.7	52.81	6.125		
7,100.0	7,059.0	7,119.7	7,060.2	26.3	27.5	-5.17	383.0	464.7	323.5	270.0	53.48	6.049		
7,200.0	7,159.0	7,219.7	7,160.2	26.6	27.9	-5.17	383.0	464.7	323.5	269.3	54.15	5.974		
7,300.0	7,259.0	7,314.5	7,254.7	27.0	28.1	-6.28	382.9	458.5	324.1	269.3	54.80	5.915 SF		
7,400.0	7,359.0	7,402.7	7,339.9	27.3	28.3	-10.15	382.8	436.3	327.8	272.4	55.35	5.922		
7,500.0	7,459.0	7,480.6	7,410.7	27.6	28.4	-15.62	382.7	403.9	337.9	282.4	55.50	6.088		
7,600.0	7,559.0	7,546.6	7,465.8	28.0	28.5	-21.40	382.5	367.8	358.2	303.4	54.80	6.536		
7,700.0	7,659.0	7,600.0	7,506.5	28.3	28.5	-26.55	382.3	333.3	390.9	337.9	53.05	7.369		
7,800.0	7,759.0	7,650.0	7,540.9	28.7	28.6	-31.50	382.2	297.0	436.1	385.3	50.78	8.588		
7,900.0	7,859.0	7,682.9	7,561.3	29.0	28.6	-34.72	382.0	271.3	492.0	444.1	47.89	10.275		
8,000.0	7,959.0	7,713.4	7,578.7	29.4	28.6	-37.65	381.9	246.2	556.8	511.6	45.23	12.310		
8,100.0	8,059.0	7,738.8	7,591.9	29.7	28.6	-40.01	381.8	224.4	628.5	585.6	42.86	14.664		
8,200.0	8,159.0	7,760.3	7,602.2	30.0	28.7	-41.94	381.7	205.5	705.4	664.6	40.83	17.275		
8,300.0	8,259.0	7,775.0	7,608.7	30.4	28.7	-43.22	381.7	192.4	786.4	747.3	39.05	20.135		
8,400.0	8,359.0	7,800.0	7,618.8	30.7	28.7	-45.32	381.6	169.5	870.5	832.6	37.92	22.958		
8,413.5	8,372.5	7,800.0	7,618.8	30.8	28.7	-45.32	381.6	169.5	882.0	844.3	37.70	23.393		
8,425.0	8,384.0	7,800.0	7,618.8	30.8	28.7	43.38	381.6	169.5	891.8	854.3	37.52	23.767		
8,450.0	8,409.0	7,800.0	7,618.8	30.9	28.7	40.23	381.6	169.5	912.9	875.8	37.13	24.585		
8,475.0	8,433.8	7,800.0	7,618.8	31.0	28.7	37.43	381.6	169.5	933.7	896.9	36.75	25.409		
8,500.0	8,458.5	7,810.4	7,622.7	31.0	28.7	34.43	381.5	159.9	953.9	917.3	36.59	26.073		
8,525.0	8,483.0	7,815.0	7,624.3	31.1	28.7	32.09	381.5	155.6	973.7	937.4	36.30	26.825		
8,550.0	8,507.2	7,825.0	7,627.8	31.2	28.7	29.84	381.5	146.2	993.1	956.9	36.12	27.492		

CC - Min centre to center distance or convergent point, SF - min separation factor, ES - min ellipse separation

Anticollision Report

Company:	NEW MEXICO	Local Co-ordinate Reference	Well KANGAROO 12 FED COM 133H
Project:	(SP) EDDY	TVD Reference:	KB @ 3288.6ft
Reference Site:	KANGAROO 12 FED	MD Reference:	KB @ 3288.6ft
Site Error:	0.0 ft	North Reference:	Grid
Reference Well:	KANGAROO 12 FED COM 133H	Survey Calculation Method:	Minimum Curvature
Well Error:	0.0 ft	Output errors are at	2.00 sigma
Reference Wellbore	OWB	Database:	Compass_17
Reference Design:	PWP0	Offset TVD Reference:	Offset Datum

Offset Design KANGAROO 12 FED - KANGAROO 12 FED COM 124H - OWB - PWP0													Offset Site Error:	0.0 ft
Survey Program: 0-MWD													Offset Well Error:	0.0 ft
Measured Depth (ft)	Reference Vertical Depth (ft)	Offset		Semi Major Axis		Highside Toolface (°)	Offset Wellbore Centre		Distance		Minimum Separation (ft)	Separation Factor	Warning	
		Measured Depth (ft)	Vertical Depth (ft)	Reference (ft)	Offset (ft)		+N/-S (ft)	+E/-W (ft)	Between Centres (ft)	Between Ellipses (ft)				
0.0	0.0	1.0	1.0	0.0	0.0	-90.11	-0.3	-165.0	165.0					
100.0	100.0	101.0	101.0	0.3	0.3	-90.11	-0.3	-165.0	165.0	164.5	0.51	326.367		
200.0	200.0	201.0	201.0	0.6	0.6	-90.11	-0.3	-165.0	165.0	163.7	1.22	134.949		
300.0	300.0	301.0	301.0	1.0	1.0	-90.11	-0.3	-165.0	165.0	163.0	1.94	85.061		
400.0	400.0	401.0	401.0	1.3	1.3	-90.11	-0.3	-165.0	165.0	162.3	2.66	62.102		
500.0	500.0	501.0	501.0	1.7	1.7	-90.11	-0.3	-165.0	165.0	161.6	3.37	48.903		
600.0	600.0	601.0	601.0	2.0	2.0	-90.11	-0.3	-165.0	165.0	160.9	4.09	40.331		
700.0	700.0	701.0	701.0	2.4	2.4	-90.11	-0.3	-165.0	165.0	160.2	4.81	34.316		
800.0	800.0	801.0	801.0	2.8	2.8	-90.11	-0.3	-165.0	165.0	159.4	5.52	29.862		
900.0	900.0	901.0	901.0	3.1	3.1	-90.11	-0.3	-165.0	165.0	158.7	6.24	26.432		
1,000.0	1,000.0	1,001.0	1,001.0	3.5	3.5	-90.11	-0.3	-165.0	165.0	158.0	6.96	23.708		
1,100.0	1,100.0	1,101.0	1,101.0	3.8	3.8	-90.11	-0.3	-165.0	165.0	157.3	7.67	21.494		
1,200.0	1,200.0	1,201.0	1,201.0	4.2	4.2	-90.11	-0.3	-165.0	165.0	156.6	8.39	19.657		
1,300.0	1,300.0	1,301.0	1,301.0	4.6	4.6	-90.11	-0.3	-165.0	165.0	155.9	9.11	18.110		
1,400.0	1,400.0	1,401.0	1,401.0	4.9	4.9	-90.11	-0.3	-165.0	165.0	155.1	9.83	16.789		
1,500.0	1,500.0	1,501.0	1,501.0	5.3	5.3	-90.11	-0.3	-165.0	165.0	154.4	10.54	15.647		
1,600.0	1,600.0	1,601.0	1,601.0	5.6	5.6	-90.11	-0.3	-165.0	165.0	153.7	11.26	14.651		
1,700.0	1,700.0	1,701.0	1,701.0	6.0	6.0	-90.11	-0.3	-165.0	165.0	153.0	11.98	13.774		
1,800.0	1,800.0	1,801.0	1,801.0	6.3	6.3	-90.11	-0.3	-165.0	165.0	152.3	12.69	12.996		
1,900.0	1,900.0	1,901.0	1,901.0	6.7	6.7	-90.11	-0.3	-165.0	165.0	151.6	13.41	12.301		
2,000.0	2,000.0	2,001.0	2,001.0	7.1	7.1	-90.11	-0.3	-165.0	165.0	150.8	14.13	11.677 CC		
2,004.5	2,004.5	2,005.7	2,005.7	7.1	7.1	-173.10	-0.3	-165.0	165.0	150.8	14.16	11.651 ES		
2,100.0	2,100.0	2,104.0	2,104.0	7.4	7.4	-173.73	-2.0	-164.0	165.8	151.0	14.83	11.181		
2,200.0	2,199.8	2,206.7	2,206.5	7.8	7.8	-175.58	-6.8	-161.2	168.4	152.9	15.50	10.864		
2,300.0	2,299.5	2,308.9	2,308.3	8.1	8.1	-178.49	-14.7	-156.6	173.1	156.9	16.18	10.701		
2,400.0	2,398.7	2,410.4	2,409.0	8.5	8.4	177.73	-25.7	-150.1	180.4	163.6	16.86	10.700 SF		
2,500.0	2,497.5	2,511.1	2,508.3	8.8	8.8	173.35	-39.6	-142.0	190.8	173.3	17.56	10.869		
2,600.0	2,595.9	2,610.7	2,606.1	9.2	9.1	168.63	-56.3	-132.2	203.1	184.8	18.27	11.118		
2,700.0	2,694.4	2,709.4	2,702.2	9.6	9.5	163.61	-75.7	-120.8	216.2	197.2	19.00	11.376		
2,800.0	2,792.9	2,806.7	2,796.2	10.0	9.9	158.56	-97.2	-108.3	230.5	210.8	19.75	11.672		
2,900.0	2,891.4	2,903.6	2,899.8	10.4	10.3	154.06	-118.9	-95.6	246.5	226.0	20.51	12.018		
3,000.0	2,989.9	3,000.5	2,983.4	10.7	10.7	150.11	-140.5	-82.9	263.8	242.5	21.28	12.397		
3,100.0	3,088.4	3,097.4	3,077.0	11.1	11.1	146.65	-162.2	-70.3	282.2	260.2	22.06	12.793		
3,200.0	3,186.8	3,194.3	3,170.6	11.6	11.6	143.61	-183.8	-57.6	301.6	278.7	22.85	13.197		
3,300.0	3,285.3	3,291.2	3,264.2	12.0	12.0	140.93	-205.5	-44.9	321.6	298.0	23.65	13.600		
3,400.0	3,383.8	3,388.1	3,357.8	12.4	12.4	138.57	-227.1	-32.3	342.3	317.8	24.45	13.998		
3,500.0	3,482.3	3,485.0	3,451.4	12.8	12.9	136.47	-248.8	-19.6	363.5	338.2	25.26	14.387		
3,600.0	3,580.8	3,581.9	3,545.0	13.2	13.4	134.61	-270.4	-6.9	385.0	359.0	26.08	14.765		
3,700.0	3,679.2	3,678.8	3,638.6	13.6	13.8	132.94	-292.1	5.7	407.0	380.1	26.90	15.130		
3,800.0	3,777.7	3,775.7	3,732.2	14.0	14.3	131.44	-313.7	18.4	429.2	401.5	27.72	15.481		
3,900.0	3,876.2	3,872.6	3,825.8	14.5	14.8	130.08	-335.4	31.1	451.7	423.1	28.55	15.819		
4,000.0	3,974.7	3,969.5	3,919.4	14.9	15.2	128.86	-357.0	43.7	474.4	445.0	29.39	16.143		
4,100.0	4,073.2	4,066.4	4,013.0	15.3	15.7	127.75	-378.7	56.4	497.3	467.1	30.23	16.453		
4,200.0	4,171.6	4,163.3	4,106.6	15.7	16.2	126.73	-400.3	69.1	520.4	489.3	31.07	16.751		
4,300.0	4,270.1	4,260.2	4,200.2	16.2	16.7	125.80	-422.0	81.7	543.6	511.7	31.91	17.035		
4,400.0	4,368.6	4,357.1	4,293.8	16.6	17.2	124.95	-443.6	94.4	566.9	534.2	32.76	17.307		
4,500.0	4,467.1	4,454.0	4,387.4	17.0	17.7	124.16	-465.2	107.1	590.4	556.8	33.61	17.567		
4,600.0	4,565.6	4,550.9	4,481.0	17.5	18.2	123.43	-486.9	119.7	613.9	579.4	34.46	17.816		
4,700.0	4,664.0	4,647.9	4,574.6	17.9	18.7	122.76	-508.5	132.4	637.5	602.2	35.31	18.055		
4,800.0	4,762.5	4,744.8	4,668.2	18.3	19.2	122.13	-530.2	145.1	661.2	625.1	36.17	18.283		
4,864.5	4,826.0	4,807.2	4,728.6	18.6	19.5	121.75	-544.1	153.2	676.5	639.8	36.72	18.425		

CC - Min centre to center distance or convergent point, SF - min separation factor, ES - min ellipse separation

Anticollision Report

Company:	NEW MEXICO	Local Co-ordinate Reference	Well KANGAROO 12 FED COM 133H
Project:	(SP) EDDY	TVD Reference:	KB @ 3288.6ft
Reference Site:	KANGAROO 12 FED	MD Reference:	KB @ 3288.6ft
Site Error:	0.0 ft	North Reference:	Grid
Reference Well:	KANGAROO 12 FED COM 133H	Survey Calculation Method:	Minimum Curvature
Well Error:	0.0 ft	Output errors are at	2.00 sigma
Reference Wellbore	OWB	Database:	Compass_17
Reference Design:	PWP0	Offset TVD Reference:	Offset Datum

Offset Design KANGAROO 12 FED - KANGAROO 12 FED COM 124H - OWB - PWP0													Offset Site Error:	0.0 ft
Survey Program: 0-MWD													Offset Well Error:	0.0 ft
Measured Depth (ft)	Vertical Reference Depth (ft)	Offset		Semi Major Axis		Highside Toolface (°)	Offset Wellbore Centre		Distance		Minimum Separation (ft)	Separation Factor	Warning	
		Measured Depth (ft)	Vertical Depth (ft)	Reference (ft)	Offset (ft)		+N/-S (ft)	+E/-W (ft)	Between Centres (ft)	Between Ellipses (ft)				
4,900.0	4,861.0	4,841.7	4,761.9	18.8	19.7	121.68	-551.8	157.7	684.9	647.9	37.02	18.500		
5,000.0	4,960.0	4,938.7	4,855.6	19.2	20.2	121.32	-573.5	170.4	707.2	669.4	37.86	18.680		
5,100.0	5,059.4	5,035.9	4,949.4	19.6	20.7	120.74	-595.2	183.1	728.0	689.3	38.67	18.823		
5,200.0	5,159.1	5,132.9	5,043.2	19.9	21.2	119.95	-616.9	195.8	747.2	707.7	39.46	18.934		
5,300.0	5,259.0	5,229.9	5,136.8	20.3	21.7	118.98	-638.6	208.5	765.0	724.8	40.22	19.021		
5,364.5	5,323.5	5,292.2	5,197.0	20.5	22.0	-158.76	-652.5	216.6	775.8	735.1	40.69	19.067		
5,400.0	5,359.0	5,326.5	5,230.2	20.6	22.2	-159.27	-660.2	221.1	781.7	740.7	40.94	19.092		
5,500.0	5,459.0	5,423.1	5,323.5	21.0	22.7	-160.69	-681.7	233.7	798.5	756.9	41.66	19.169		
5,600.0	5,559.0	5,519.7	5,416.8	21.3	23.3	-162.05	-703.3	246.4	815.9	773.5	42.37	19.257		
5,700.0	5,659.0	5,616.3	5,510.1	21.6	23.8	-163.35	-724.9	259.0	833.6	790.6	43.07	19.354		
5,800.0	5,759.0	5,712.9	5,603.4	21.9	24.3	-164.60	-746.5	271.6	851.8	808.0	43.78	19.458		
5,900.0	5,859.0	5,809.5	5,696.7	22.3	24.8	-165.80	-768.0	284.2	870.4	825.9	44.48	19.569		
6,000.0	5,959.0	5,906.1	5,790.0	22.6	25.3	-166.95	-789.6	296.9	889.3	844.2	45.18	19.686		
6,100.0	6,059.0	6,002.7	5,883.3	22.9	25.8	-168.06	-811.2	309.5	908.6	862.8	45.87	19.808		
6,200.0	6,159.0	6,099.3	5,976.6	23.3	26.3	-169.12	-832.8	322.1	928.2	881.7	46.57	19.934		
6,300.0	6,259.0	6,198.5	6,072.4	23.6	26.9	-170.16	-854.9	335.1	948.1	900.8	47.29	20.050		
6,400.0	6,359.0	6,330.0	6,200.3	23.9	27.5	-171.35	-881.4	350.5	966.3	918.0	48.31	20.004		
6,500.0	6,459.0	6,464.1	6,332.1	24.3	28.2	-172.28	-903.1	363.3	981.1	931.8	49.28	19.910		
6,600.0	6,559.0	6,600.4	6,467.0	24.6	28.7	-172.97	-919.7	373.0	992.3	942.1	50.19	19.771		
6,700.0	6,659.0	6,738.3	6,604.2	24.9	29.3	-173.42	-930.9	379.5	999.8	948.8	51.03	19.593		

CC - Min centre to center distance or covergent point, SF - min separation factor, ES - min ellipse separation

Anticollision Report

Company:	NEW MEXICO	Local Co-ordinate Reference	Well KANGAROO 12 FED COM 133H
Project:	(SP) EDDY	TVD Reference:	KB @ 3288.6ft
Reference Site:	KANGAROO 12 FED	MD Reference:	KB @ 3288.6ft
Site Error:	0.0 ft	North Reference:	Grid
Reference Well:	KANGAROO 12 FED COM 133H	Survey Calculation Method:	Minimum Curvature
Well Error:	0.0 ft	Output errors are at	2.00 sigma
Reference Wellbore	OWB	Database:	Compass_17
Reference Design:	PWP0	Offset TVD Reference:	Offset Datum

Offset Design KANGAROO 12 FED - KANGAROO 12 FED COM 134H - OWB - PWP0													Offset Site Error:	0.0 ft
Survey Program: 0-MWD													Offset Well Error:	0.0 ft
Measured Depth (ft)	Reference Vertical Depth (ft)	Offset		Semi Major Axis		Highside Toolface (°)	Offset Wellbore Centre		Distance		Minimum Separation (ft)	Separation Factor	Warning	
		Measured Depth (ft)	Vertical Depth (ft)	Reference (ft)	Offset (ft)		+N/-S (ft)	+E/-W (ft)	Between Centres (ft)	Between Ellipses (ft)				
0.0	0.0	0.2	0.2	0.0	0.0	-90.10	-0.1	-33.0	33.0					
100.0	100.0	100.2	100.2	0.3	0.3	-90.10	-0.1	-33.0	33.0	32.5	0.50	65.642		
200.0	200.0	200.2	200.2	0.6	0.6	-90.10	-0.1	-33.0	33.0	31.8	1.22	27.052		
300.0	300.0	300.2	300.2	1.0	1.0	-90.10	-0.1	-33.0	33.0	31.1	1.94	17.036		
400.0	400.0	400.2	400.2	1.3	1.3	-90.10	-0.1	-33.0	33.0	30.3	2.65	12.433		
500.0	500.0	500.2	500.2	1.7	1.7	-90.10	-0.1	-33.0	33.0	29.6	3.37	9.788		
600.0	600.0	600.2	600.2	2.0	2.0	-90.10	-0.1	-33.0	33.0	28.9	4.09	8.071		
700.0	700.0	700.2	700.2	2.4	2.4	-90.10	-0.1	-33.0	33.0	28.2	4.80	6.867		
800.0	800.0	800.2	800.2	2.8	2.8	-90.10	-0.1	-33.0	33.0	27.5	5.52	5.975		
900.0	900.0	900.2	900.2	3.1	3.1	-90.10	-0.1	-33.0	33.0	26.8	6.24	5.288		
1,000.0	1,000.0	1,000.2	1,000.2	3.5	3.5	-90.10	-0.1	-33.0	33.0	26.0	6.96	4.743		
1,100.0	1,100.0	1,100.2	1,100.2	3.8	3.8	-90.10	-0.1	-33.0	33.0	25.3	7.67	4.300		
1,200.0	1,200.0	1,200.2	1,200.2	4.2	4.2	-90.10	-0.1	-33.0	33.0	24.6	8.39	3.933		
1,300.0	1,300.0	1,300.2	1,300.2	4.6	4.6	-90.10	-0.1	-33.0	33.0	23.9	9.11	3.623		
1,400.0	1,400.0	1,400.2	1,400.2	4.9	4.9	-90.10	-0.1	-33.0	33.0	23.2	9.82	3.359		
1,500.0	1,500.0	1,500.2	1,500.2	5.3	5.3	-90.10	-0.1	-33.0	33.0	22.5	10.54	3.130		
1,600.0	1,600.0	1,600.2	1,600.2	5.6	5.6	-90.10	-0.1	-33.0	33.0	21.7	11.26	2.931		
1,700.0	1,700.0	1,700.2	1,700.2	6.0	6.0	-90.10	-0.1	-33.0	33.0	21.0	11.97	2.755		
1,800.0	1,800.0	1,800.2	1,800.2	6.3	6.3	-90.10	-0.1	-33.0	33.0	20.3	12.69	2.600		
1,900.0	1,900.0	1,900.2	1,900.2	6.7	6.7	-90.10	-0.1	-33.0	33.0	19.6	13.41	2.461		
2,000.0	2,000.0	2,000.6	2,000.6	7.1	7.0	-93.01	-1.7	-32.3	32.4	18.3	14.11	2.296		
2,038.0	2,038.0	2,038.7	2,038.6	7.2	7.2	-178.71	-3.2	-31.8	32.2	17.8	14.36	2.239 CC, ES		
2,100.0	2,100.0	2,100.7	2,100.6	7.4	7.4	175.05	-6.6	-30.4	32.8	18.1	14.78	2.222 SF		
2,200.0	2,199.8	2,200.4	2,199.8	7.8	7.7	162.48	-14.7	-27.2	37.5	22.0	15.46	2.426		
2,300.0	2,299.5	2,299.3	2,298.0	8.1	8.0	150.82	-25.9	-22.8	47.4	31.3	16.13	2.937		
2,400.0	2,398.7	2,397.2	2,394.7	8.5	8.4	142.28	-40.1	-17.1	62.6	45.8	16.79	3.726		
2,500.0	2,497.5	2,493.9	2,489.6	8.8	8.7	136.56	-57.1	-10.4	82.6	65.2	17.45	4.735		
2,600.0	2,595.9	2,589.3	2,582.6	9.2	9.1	132.44	-76.8	-2.6	106.0	87.9	18.11	5.857		
2,700.0	2,694.4	2,684.3	2,674.6	9.6	9.4	128.71	-99.1	6.2	131.5	112.8	18.77	7.008		
2,800.0	2,792.9	2,780.6	2,767.6	10.0	9.8	125.96	-122.2	15.4	157.8	138.3	19.48	8.101		
2,900.0	2,891.4	2,876.8	2,860.6	10.4	10.2	123.99	-145.4	24.6	184.3	164.1	20.21	9.121		
3,000.0	2,989.9	2,973.1	2,953.6	10.7	10.7	122.52	-168.6	33.8	211.0	190.0	20.95	10.070		
3,100.0	3,088.4	3,069.4	3,046.5	11.1	11.1	121.38	-191.7	43.0	237.7	216.0	21.70	10.954		
3,200.0	3,186.8	3,165.6	3,139.5	11.6	11.5	120.47	-214.9	52.1	264.5	242.1	22.46	11.776		
3,300.0	3,285.3	3,261.9	3,232.5	12.0	12.0	119.73	-238.0	61.3	291.4	268.2	23.24	12.541		
3,400.0	3,383.8	3,358.1	3,325.5	12.4	12.4	119.11	-261.2	70.5	318.3	294.3	24.02	13.254		
3,500.0	3,482.3	3,454.4	3,418.4	12.8	12.9	118.59	-284.4	79.7	345.3	320.5	24.80	13.920		
3,600.0	3,580.8	3,550.6	3,511.4	13.2	13.3	118.14	-307.5	88.8	372.2	346.6	25.60	14.542		
3,700.0	3,679.2	3,646.9	3,604.4	13.6	13.8	117.76	-330.7	98.0	399.2	372.8	26.40	15.124		
3,800.0	3,777.7	3,743.2	3,697.4	14.0	14.3	117.42	-353.8	107.2	426.2	399.0	27.20	15.670		
3,900.0	3,876.2	3,839.4	3,790.4	14.5	14.7	117.12	-377.0	116.4	453.2	425.2	28.01	16.181		
4,000.0	3,974.7	3,935.7	3,883.3	14.9	15.2	116.86	-400.2	125.6	480.3	451.4	28.82	16.663		
4,100.0	4,073.2	4,031.9	3,976.3	15.3	15.7	116.62	-423.3	134.7	507.3	477.6	29.64	17.115		
4,200.0	4,171.6	4,128.2	4,069.3	15.7	16.2	116.41	-446.5	143.9	534.3	503.9	30.46	17.542		
4,300.0	4,270.1	4,224.5	4,162.3	16.2	16.7	116.22	-469.6	153.1	561.4	530.1	31.28	17.945		
4,400.0	4,368.6	4,320.7	4,255.2	16.6	17.2	116.05	-492.8	162.3	588.4	556.3	32.11	18.325		
4,500.0	4,467.1	4,417.0	4,348.2	17.0	17.7	115.89	-516.0	171.4	615.5	582.5	32.94	18.685		
4,600.0	4,565.6	4,513.2	4,441.2	17.5	18.2	115.74	-539.1	180.6	642.5	608.8	33.77	19.026		
4,700.0	4,664.0	4,609.5	4,534.2	17.9	18.7	115.61	-562.3	189.8	669.6	635.0	34.60	19.349		
4,800.0	4,762.5	4,705.7	4,627.2	18.3	19.2	115.49	-585.5	199.0	696.6	661.2	35.44	19.656		
4,864.5	4,826.0	4,767.8	4,687.1	18.6	19.5	115.41	-600.4	204.9	714.1	678.1	35.98	19.846		

CC - Min centre to center distance or convergent point, SF - min separation factor, ES - min ellipse separation

Anticollision Report

Company:	NEW MEXICO	Local Co-ordinate Reference	Well KANGAROO 12 FED COM 133H
Project:	(SP) EDDY	TVD Reference:	KB @ 3288.6ft
Reference Site:	KANGAROO 12 FED	MD Reference:	KB @ 3288.6ft
Site Error:	0.0 ft	North Reference:	Grid
Reference Well:	KANGAROO 12 FED COM 133H	Survey Calculation Method:	Minimum Curvature
Well Error:	0.0 ft	Output errors are at	2.00 sigma
Reference Wellbore	OWB	Database:	Compass_17
Reference Design:	PWP0	Offset TVD Reference:	Offset Datum

Offset Design													Offset Site Error:	0.0 ft		
KANGAROO 12 FED - KANGAROO 12 FED COM 134H - OWB - PWP0													Offset Well Error:	0.0 ft		
Survey Program: 0-MWD													Rule Assigned:		Warning	
Measured Reference Depth (ft)	Vertical Reference Depth (ft)	Measured Offset Depth (ft)	Vertical Offset Depth (ft)	Semi Major Axis Reference Offset (ft)		Highside Toolface (°)	Offset Wellbore Centre +N/-S (ft) +E/-W (ft)		Distance Between Centres (ft) Between Ellipses (ft)		Minimum Separation (ft)	Separation Factor				
4,900.0	4,861.0	4,802.0	4,720.2	18.8	19.7	115.54	-608.6	208.2	723.6	687.3	36.28	19.947				
5,000.0	4,960.0	4,898.5	4,813.4	19.2	20.2	115.70	-631.8	217.4	749.5	712.4	37.10	20.203				
5,100.0	5,059.4	4,995.3	4,906.8	19.6	20.7	115.62	-655.1	226.6	773.9	736.0	37.89	20.425				
5,200.0	5,159.1	5,092.1	5,000.3	19.9	21.2	115.31	-678.4	235.8	796.9	758.2	38.65	20.616				
5,300.0	5,259.0	5,188.8	5,093.8	20.3	21.7	114.80	-701.7	245.0	818.7	779.3	39.39	20.782				
5,364.5	5,323.5	5,251.1	5,154.0	20.5	22.0	-162.65	-716.7	251.0	832.0	792.2	39.85	20.879				
5,400.0	5,359.0	5,285.5	5,187.1	20.6	22.2	-163.04	-724.9	254.3	839.3	799.2	40.10	20.931				
5,500.0	5,459.0	5,382.1	5,280.4	21.0	22.7	-164.10	-748.2	263.5	859.9	819.1	40.80	21.078				
5,600.0	5,559.0	5,478.7	5,373.7	21.3	23.2	-165.11	-771.4	272.7	880.9	839.4	41.50	21.227				
5,700.0	5,659.0	5,575.3	5,467.0	21.6	23.7	-166.08	-794.7	281.9	902.1	859.9	42.20	21.378				
5,800.0	5,759.0	5,671.8	5,560.3	21.9	24.3	-167.00	-817.9	291.1	923.5	880.6	42.89	21.530				
5,900.0	5,859.0	5,768.4	5,653.6	22.3	24.8	-167.89	-841.2	300.3	945.1	901.5	43.59	21.682				
6,000.0	5,959.0	5,865.0	5,746.9	22.6	25.3	-168.73	-864.4	309.5	967.0	922.7	44.29	21.834				
6,100.0	6,059.0	5,961.6	5,840.2	22.9	25.8	-169.54	-887.6	318.7	989.0	944.0	44.98	21.986				

CC - Min centre to center distance or covergent point, SF - min separation factor, ES - min ellipse separation

Anticollision Report

Company:	NEW MEXICO	Local Co-ordinate Reference	Well KANGAROO 12 FED COM 133H
Project:	(SP) EDDY	TVD Reference:	KB @ 3288.6ft
Reference Site:	KANGAROO 12 FED	MD Reference:	KB @ 3288.6ft
Site Error:	0.0 ft	North Reference:	Grid
Reference Well:	KANGAROO 12 FED COM 133H	Survey Calculation Method:	Minimum Curvature
Well Error:	0.0 ft	Output errors are at	2.00 sigma
Reference Wellbore	OWB	Database:	Compass_17
Reference Design:	PWP0	Offset TVD Reference:	Offset Datum

Offset Design KANGAROO 12 FED - KANGAROO 12 FED COM 203H - OWB - PWP0													Offset Site Error:	0.0 ft
Survey Program: 0-MWD													Offset Well Error:	0.0 ft
Measured Depth (ft)	Vertical Depth (ft)	Offset		Semi Major Axis		Highside Toolface (°)	Offset Wellbore Centre		Distance		Minimum Separation (ft)	Separation Factor	Warning	
		Measured Depth (ft)	Vertical Depth (ft)	Reference (ft)	Offset (ft)		+N/-S (ft)	+E/-W (ft)	Between Centres (ft)	Between Ellipses (ft)				
0.0	0.0	0.4	0.4	0.0	0.0	-90.11	-0.1	-66.0	66.0					
100.0	100.0	100.4	100.4	0.3	0.3	-90.11	-0.1	-66.0	66.0	65.5	0.50	131.097		
200.0	200.0	200.4	200.4	0.6	0.6	-90.11	-0.1	-66.0	66.0	64.8	1.22	54.072		
300.0	300.0	300.4	300.4	1.0	1.0	-90.11	-0.1	-66.0	66.0	64.0	1.94	34.060		
400.0	400.0	400.4	400.4	1.3	1.3	-90.11	-0.1	-66.0	66.0	63.3	2.65	24.860		
500.0	500.0	500.4	500.4	1.7	1.7	-90.11	-0.1	-66.0	66.0	62.6	3.37	19.573		
600.0	600.0	600.4	600.4	2.0	2.0	-90.11	-0.1	-66.0	66.0	61.9	4.09	16.140		
700.0	700.0	700.4	700.4	2.4	2.4	-90.11	-0.1	-66.0	66.0	61.2	4.80	13.732		
800.0	800.0	800.4	800.4	2.8	2.8	-90.11	-0.1	-66.0	66.0	60.5	5.52	11.949		
900.0	900.0	900.4	900.4	3.1	3.1	-90.11	-0.1	-66.0	66.0	59.7	6.24	10.576		
1,000.0	1,000.0	1,000.4	1,000.4	3.5	3.5	-90.11	-0.1	-66.0	66.0	59.0	6.96	9.486		
1,100.0	1,100.0	1,100.4	1,100.4	3.8	3.8	-90.11	-0.1	-66.0	66.0	58.3	7.67	8.599		
1,200.0	1,200.0	1,200.4	1,200.4	4.2	4.2	-90.11	-0.1	-66.0	66.0	57.6	8.39	7.864		
1,300.0	1,300.0	1,300.4	1,300.4	4.6	4.6	-90.11	-0.1	-66.0	66.0	56.9	9.11	7.245		
1,400.0	1,400.0	1,400.4	1,400.4	4.9	4.9	-90.11	-0.1	-66.0	66.0	56.2	9.82	6.717		
1,500.0	1,500.0	1,500.4	1,500.4	5.3	5.3	-90.11	-0.1	-66.0	66.0	55.4	10.54	6.260		
1,600.0	1,600.0	1,600.4	1,600.4	5.6	5.6	-90.11	-0.1	-66.0	66.0	54.7	11.26	5.861		
1,700.0	1,700.0	1,700.4	1,700.4	6.0	6.0	-90.11	-0.1	-66.0	66.0	54.0	11.97	5.510		
1,800.0	1,800.0	1,800.4	1,800.4	6.3	6.3	-90.11	-0.1	-66.0	66.0	53.3	12.69	5.199		
1,900.0	1,900.0	1,900.4	1,900.4	6.7	6.7	-90.11	-0.1	-66.0	66.0	52.6	13.41	4.921		
2,000.0	2,000.0	2,000.4	2,000.4	7.1	7.1	-90.11	-0.1	-66.0	66.0	51.9	14.13	4.671 CC		
2,004.5	2,004.5	2,005.0	2,005.0	7.1	7.1	-173.09	-0.1	-66.0	66.0	51.8	14.16	4.661 ES		
2,100.0	2,100.0	2,101.7	2,101.6	7.4	7.4	-171.98	1.4	-65.0	66.7	51.9	14.83	4.499		
2,200.0	2,199.8	2,202.8	2,202.6	7.8	7.8	-168.83	5.9	-62.0	69.2	53.7	15.53	4.455		
2,300.0	2,299.5	2,303.7	2,303.1	8.1	8.1	-164.07	13.3	-57.1	73.7	57.5	16.23	4.540		
2,400.0	2,398.7	2,404.1	2,402.8	8.5	8.5	-158.38	23.6	-50.3	80.7	63.8	16.93	4.765		
2,500.0	2,497.5	2,504.1	2,501.5	8.8	8.9	-152.44	36.8	-41.7	90.6	73.0	17.65	5.133		
2,600.0	2,595.9	2,603.4	2,599.0	9.2	9.2	-146.40	52.8	-31.2	102.3	83.9	18.39	5.562		
2,700.0	2,694.4	2,702.1	2,695.5	9.6	9.6	-140.86	69.9	-19.9	114.8	95.6	19.13	5.998		
2,800.0	2,792.9	2,800.8	2,792.0	10.0	10.0	-136.43	87.1	-8.7	128.1	108.2	19.89	6.440		
2,900.0	2,891.4	2,899.4	2,888.5	10.4	10.4	-132.84	104.2	2.6	142.1	121.4	20.66	6.877		
3,000.0	2,989.9	2,998.1	2,985.0	10.7	10.8	-129.90	121.3	13.9	156.5	135.0	21.44	7.300		
3,100.0	3,088.4	3,096.8	3,081.5	11.1	11.2	-127.46	138.5	25.1	171.2	149.0	22.22	7.705		
3,200.0	3,186.8	3,195.4	3,178.0	11.6	11.6	-125.41	155.6	36.4	186.2	163.2	23.02	8.091		
3,300.0	3,285.3	3,294.1	3,274.6	12.0	12.0	-123.67	172.8	47.7	201.4	177.6	23.82	8.457		
3,400.0	3,383.8	3,392.8	3,371.1	12.4	12.5	-122.17	189.9	58.9	216.8	192.1	24.63	8.803		
3,500.0	3,482.3	3,491.4	3,467.6	12.8	12.9	-120.87	207.1	70.2	232.3	206.8	25.44	9.130		
3,600.0	3,580.8	3,590.1	3,564.1	13.2	13.3	-119.73	224.2	81.5	247.8	221.6	26.26	9.438		
3,700.0	3,679.2	3,688.8	3,660.6	13.6	13.8	-118.73	241.3	92.7	263.5	236.4	27.08	9.730		
3,800.0	3,777.7	3,787.4	3,757.1	14.0	14.2	-117.84	258.5	104.0	279.2	251.3	27.91	10.005		
3,900.0	3,876.2	3,886.1	3,853.6	14.5	14.6	-117.04	275.6	115.3	295.0	266.3	28.74	10.265		
4,000.0	3,974.7	3,984.8	3,950.1	14.9	15.1	-116.33	292.8	126.5	310.9	281.3	29.58	10.511		
4,100.0	4,073.2	4,083.4	4,046.6	15.3	15.5	-115.68	309.9	137.8	326.8	296.4	30.42	10.743		
4,200.0	4,171.6	4,182.1	4,143.1	15.7	15.9	-115.10	327.1	149.1	342.7	311.5	31.26	10.963		
4,300.0	4,270.1	4,280.8	4,239.7	16.2	16.4	-114.56	344.2	160.4	358.7	326.6	32.11	11.172		
4,400.0	4,368.6	4,379.4	4,336.2	16.6	16.8	-114.07	361.3	171.6	374.7	341.7	32.95	11.370		
4,500.0	4,467.1	4,478.1	4,432.7	17.0	17.3	-113.63	378.5	182.9	390.7	356.9	33.80	11.557		
4,600.0	4,565.6	4,576.8	4,529.2	17.5	17.7	-113.21	395.6	194.2	406.7	372.1	34.65	11.736		
4,700.0	4,664.0	4,675.4	4,625.7	17.9	18.2	-112.83	412.8	205.4	422.8	387.2	35.51	11.906		
4,800.0	4,762.5	4,774.1	4,722.2	18.3	18.6	-112.48	429.9	216.7	438.8	402.5	36.36	12.068		
4,864.5	4,826.0	4,837.7	4,784.4	18.6	18.9	-112.26	441.0	224.0	449.2	412.3	36.92	12.168		

CC - Min centre to center distance or convergent point, SF - min separation factor, ES - min ellipse separation

Anticollision Report

Company:	NEW MEXICO	Local Co-ordinate Reference	Well KANGAROO 12 FED COM 133H
Project:	(SP) EDDY	TVD Reference:	KB @ 3288.6ft
Reference Site:	KANGAROO 12 FED	MD Reference:	KB @ 3288.6ft
Site Error:	0.0 ft	North Reference:	Grid
Reference Well:	KANGAROO 12 FED COM 133H	Survey Calculation Method:	Minimum Curvature
Well Error:	0.0 ft	Output errors are at	2.00 sigma
Reference Wellbore	OWB	Database:	Compass_17
Reference Design:	PWP0	Offset TVD Reference:	Offset Datum

Offset Design KANGAROO 12 FED - KANGAROO 12 FED COM 203H - OWB - PWP0												Offset Site Error:	0.0 ft		
Survey Program: 0-MWD												Rule Assigned:		Offset Well Error:	0.0 ft
Measured Depth (ft)	Vertical Reference Depth (ft)	Offset		Semi Major Axis		Highside Toolface (°)	Offset Wellbore Centre		Distance		Minimum Separation (ft)	Separation Factor	Warning		
		Measured Depth (ft)	Vertical Depth (ft)	Reference (ft)	Offset (ft)		+N/-S (ft)	+E/-W (ft)	Between Centres (ft)	Between Ellipses (ft)					
4,900.0	4,861.0	4,872.8	4,818.7	18.8	19.1	-112.23	447.0	228.0	454.8	417.6	37.22	12.220			
5,000.0	4,960.0	4,971.5	4,915.3	19.2	19.5	-111.86	464.2	239.2	469.8	431.8	38.06	12.345			
5,100.0	5,059.4	5,070.2	5,011.8	19.6	20.0	-111.13	481.3	250.5	483.7	444.8	38.88	12.441			
5,200.0	5,159.1	5,168.7	5,108.2	19.9	20.5	-110.06	498.5	261.8	496.4	456.8	39.67	12.515			
5,300.0	5,259.0	5,267.0	5,204.3	20.3	20.9	-108.68	515.5	273.0	508.3	467.9	40.43	12.574			
5,364.5	5,323.5	5,330.1	5,266.1	20.5	21.2	-24.65	526.5	280.2	515.7	474.8	40.90	12.607			
5,400.0	5,359.0	5,364.9	5,300.1	20.6	21.4	-23.97	532.6	284.2	519.7	478.5	41.16	12.626			
5,500.0	5,459.0	5,462.7	5,395.8	21.0	21.8	-22.11	549.5	295.3	531.4	489.5	41.87	12.690			
5,600.0	5,559.0	5,560.5	5,491.5	21.3	22.3	-20.33	566.5	306.5	543.6	501.0	42.59	12.765			
5,700.0	5,659.0	5,658.3	5,587.1	21.6	22.7	-18.63	583.5	317.7	556.4	513.1	43.29	12.851			
5,800.0	5,759.0	5,756.2	5,682.8	21.9	23.2	-17.00	600.5	328.8	569.6	525.6	43.99	12.947			
5,900.0	5,859.0	5,854.0	5,778.5	22.3	23.6	-15.45	617.5	340.0	583.2	538.6	44.69	13.051			
6,000.0	5,959.0	5,951.8	5,874.2	22.6	24.1	-13.97	634.5	351.2	597.3	551.9	45.39	13.161			
6,100.0	6,059.0	6,049.6	5,969.8	22.9	24.6	-12.55	651.5	362.4	611.8	565.7	46.08	13.277			
6,200.0	6,159.0	6,156.1	6,074.1	23.3	25.1	-11.12	669.6	374.2	626.3	579.4	46.85	13.367			
6,300.0	6,259.0	6,273.5	6,189.8	23.6	25.6	-9.87	686.1	385.1	638.6	590.8	47.70	13.386			
6,400.0	6,359.0	6,392.4	6,307.7	23.9	26.1	-8.94	698.9	393.5	648.0	599.5	48.52	13.355			
6,500.0	6,459.0	6,512.3	6,427.2	24.3	26.5	-8.33	707.6	399.2	654.5	605.2	49.29	13.277			
6,600.0	6,559.0	6,632.9	6,547.7	24.6	26.9	-8.02	712.1	402.2	657.8	607.8	50.01	13.153			
6,700.0	6,659.0	6,744.7	6,659.4	24.9	27.3	-7.97	712.8	402.6	658.3	607.6	50.69	12.987			
6,800.0	6,759.0	6,844.7	6,759.4	25.3	27.6	-7.97	712.8	402.6	658.3	607.0	51.35	12.819			
6,900.0	6,859.0	6,944.7	6,859.4	25.6	27.9	-7.97	712.8	402.6	658.3	606.3	52.02	12.655			
7,000.0	6,959.0	7,044.7	6,959.4	25.9	28.2	-7.97	712.8	402.6	658.3	605.6	52.69	12.495			
7,100.0	7,059.0	7,144.7	7,059.4	26.3	28.5	-7.97	712.8	402.6	658.3	605.0	53.36	12.339			
7,200.0	7,159.0	7,244.7	7,159.4	26.6	28.8	-7.97	712.8	402.6	658.3	604.3	54.02	12.186			
7,300.0	7,259.0	7,344.7	7,259.4	27.0	29.1	-7.97	712.8	402.6	658.3	603.6	54.70	12.036			
7,400.0	7,359.0	7,444.7	7,359.4	27.3	29.5	-7.97	712.8	402.6	658.3	603.0	55.37	11.890			
7,500.0	7,459.0	7,544.7	7,459.4	27.6	29.8	-7.97	712.8	402.6	658.3	602.3	56.04	11.748			
7,600.0	7,559.0	7,644.7	7,559.4	28.0	30.1	-7.97	712.8	402.6	658.3	601.6	56.71	11.608			
7,700.0	7,659.0	7,744.7	7,659.4	28.3	30.4	-7.97	712.8	402.6	658.3	600.9	57.39	11.471			
7,800.0	7,759.0	7,844.7	7,759.4	28.7	30.7	-7.97	712.8	402.6	658.3	600.3	58.06	11.338			
7,900.0	7,859.0	7,944.7	7,859.4	29.0	31.1	-7.97	712.8	402.6	658.3	599.6	58.74	11.207			
8,000.0	7,959.0	8,044.7	7,959.4	29.4	31.4	-7.97	712.8	402.6	658.3	598.9	59.42	11.079			
8,100.0	8,059.0	8,144.7	8,059.4	29.7	31.7	-7.97	712.8	402.6	658.3	598.2	60.10	10.954			
8,200.0	8,159.0	8,244.7	8,159.4	30.0	32.0	-7.97	712.8	402.6	658.3	597.6	60.78	10.832			
8,300.0	8,259.0	8,344.7	8,259.4	30.4	32.3	-7.97	712.8	402.6	658.3	596.9	61.46	10.712			
8,400.0	8,359.0	8,444.7	8,359.4	30.7	32.7	-7.97	712.8	402.6	658.3	596.2	62.14	10.594			
8,413.5	8,372.5	8,458.2	8,372.9	30.8	32.7	-7.97	712.8	402.6	658.3	596.1	62.23	10.579			
8,425.0	8,384.0	8,469.7	8,384.4	30.8	32.7	82.31	712.8	402.6	658.3	596.0	62.31	10.565			
8,450.0	8,409.0	8,494.6	8,409.4	30.9	32.8	82.44	712.8	402.6	658.1	595.7	62.47	10.536			
8,475.0	8,433.8	8,519.5	8,434.2	31.0	32.9	82.70	712.8	402.6	657.8	595.2	62.61	10.506			
8,500.0	8,458.5	8,544.2	8,458.9	31.0	33.0	83.09	712.8	402.6	657.3	594.6	62.75	10.475			
8,525.0	8,483.0	8,568.7	8,483.4	31.1	33.1	83.60	712.8	402.6	656.7	593.8	62.89	10.443			
8,550.0	8,507.2	8,592.8	8,507.6	31.2	33.1	84.22	712.8	402.6	656.0	593.0	63.01	10.411			
8,575.0	8,530.9	8,616.6	8,531.3	31.2	33.2	84.95	712.8	402.6	655.3	592.1	63.12	10.381			
8,600.0	8,554.3	8,640.0	8,554.7	31.3	33.3	85.76	712.8	402.6	654.5	591.3	63.23	10.351			
8,625.0	8,577.2	8,662.8	8,577.6	31.3	33.4	86.66	712.8	402.6	653.8	590.4	63.32	10.324			
8,650.0	8,599.5	8,685.1	8,599.9	31.4	33.5	87.62	712.8	402.6	653.1	589.7	63.41	10.300			
8,675.0	8,621.1	8,706.8	8,621.5	31.4	33.5	88.62	712.8	402.6	652.7	589.2	63.49	10.280			
8,700.0	8,642.1	8,727.8	8,642.5	31.5	33.6	89.65	712.8	402.6	652.4	588.9	63.56	10.265			
8,708.4	8,649.0	8,734.7	8,649.4	31.5	33.6	90.00	712.8	402.6	652.4	588.8	63.58	10.261			

CC - Min centre to center distance or convergent point, SF - min separation factor, ES - min ellipse separation

Anticollision Report

Company:	NEW MEXICO	Local Co-ordinate Reference	Well KANGAROO 12 FED COM 133H
Project:	(SP) EDDY	TVD Reference:	KB @ 3288.6ft
Reference Site:	KANGAROO 12 FED	MD Reference:	KB @ 3288.6ft
Site Error:	0.0 ft	North Reference:	Grid
Reference Well:	KANGAROO 12 FED COM 133H	Survey Calculation Method:	Minimum Curvature
Well Error:	0.0 ft	Output errors are at	2.00 sigma
Reference Wellbore	OWB	Database:	Compass_17
Reference Design:	PWP0	Offset TVD Reference:	Offset Datum

Offset Design KANGAROO 12 FED - KANGAROO 12 FED COM 203H - OWB - PWP0													Offset Site Error:	0.0 ft		
Survey Program: 0-MWD													Rule Assigned:		Offset Well Error:	0.0 ft
Measured Depth (ft)	Vertical Depth (ft)	Offset		Semi Major Axis		Highside Toolface (°)	Offset Wellbore Centre		Distance		Minimum Separation (ft)	Separation Factor	Warning			
		Measured Depth (ft)	Vertical Depth (ft)	Reference (ft)	Offset (ft)		+N/-S (ft)	+E/-W (ft)	Between Centres (ft)	Between Ellipses (ft)						
8,725.0	8,662.4	8,748.0	8,662.8	31.5	33.7	90.69	712.8	402.6	652.5	588.8	63.62	10.255				
8,750.0	8,681.8	8,767.8	8,682.5	31.6	33.7	91.72	712.8	402.6	652.9	589.2	63.68	10.253				
8,775.0	8,700.5	8,788.4	8,703.1	31.6	33.8	92.78	712.8	401.9	653.7	590.0	63.72	10.259				
8,800.0	8,718.2	8,809.6	8,724.2	31.7	33.8	93.84	712.8	400.3	655.0	591.2	63.76	10.271				
8,825.0	8,734.9	8,831.5	8,746.0	31.7	33.9	94.90	712.7	397.7	656.6	592.8	63.80	10.292				
8,850.0	8,750.7	8,854.2	8,768.4	31.8	34.0	95.95	712.7	393.9	658.7	594.8	63.82	10.320				
8,875.0	8,765.4	8,877.8	8,791.4	31.8	34.0	97.01	712.7	388.8	661.2	597.3	63.84	10.357				
8,900.0	8,779.1	8,902.5	8,815.2	31.9	34.1	98.08	712.7	382.3	664.1	600.2	63.84	10.403				
8,925.0	8,791.6	8,928.3	8,839.8	31.9	34.1	99.16	712.6	374.2	667.3	603.5	63.81	10.458				
8,950.0	8,803.0	8,955.6	8,865.1	32.0	34.2	100.26	712.6	364.2	671.0	607.3	63.77	10.523				
8,975.0	8,813.3	8,984.4	8,891.3	32.1	34.2	101.38	712.5	352.1	675.0	611.4	63.69	10.599				
9,000.0	8,822.3	9,015.2	8,918.3	32.2	34.3	102.54	712.5	337.5	679.4	615.8	63.57	10.687				
9,025.0	8,830.0	9,048.0	8,946.1	32.2	34.3	103.73	712.4	319.9	684.0	620.6	63.40	10.788				
9,050.0	8,836.6	9,083.4	8,974.6	32.3	34.4	104.98	712.3	299.0	688.9	625.7	63.19	10.902				
9,075.0	8,841.8	9,121.7	9,003.5	32.4	34.4	106.27	712.2	274.0	693.9	630.9	62.91	11.030				
9,100.0	8,845.8	9,163.3	9,032.7	32.5	34.4	107.61	712.0	244.3	698.9	636.3	62.58	11.169				
9,125.0	8,848.4	9,208.8	9,061.4	32.7	34.4	109.00	711.8	209.0	703.9	641.7	62.20	11.318				
9,150.0	8,849.8	9,258.6	9,088.9	32.8	34.4	110.40	711.6	167.5	708.8	647.0	61.80	11.469				
9,163.5	8,850.0	9,287.5	9,102.8	32.8	34.4	111.15	711.5	142.2	711.3	649.7	61.59	11.549				
9,200.0	8,850.0	9,374.0	9,135.0	33.0	34.4	113.57	711.2	62.0	716.8	655.6	61.18	11.717				
9,300.0	8,850.0	9,561.1	9,155.0	33.7	34.5	115.03	710.3	-123.1	720.0	658.0	62.02	11.608				
9,400.0	8,850.0	9,661.1	9,155.0	34.5	35.0	115.03	709.8	-223.1	720.0	656.7	63.28	11.378				
9,500.0	8,850.0	9,761.1	9,155.0	35.4	35.8	115.03	709.3	-323.1	720.0	655.2	64.80	11.110				
9,600.0	8,850.0	9,861.1	9,155.0	36.5	36.7	115.03	708.9	-423.1	720.0	653.4	66.59	10.812				
9,700.0	8,850.0	9,961.1	9,155.0	37.7	37.8	115.03	708.4	-523.1	720.0	651.4	68.62	10.492				
9,800.0	8,850.0	10,061.1	9,155.0	39.0	39.0	115.03	707.9	-623.1	720.0	649.1	70.86	10.160				
9,900.0	8,850.0	10,161.1	9,155.0	40.4	40.3	115.03	707.4	-723.1	720.0	646.7	73.31	9.821				
10,000.0	8,850.0	10,261.1	9,155.0	41.9	41.7	115.03	707.0	-823.1	720.0	644.0	75.93	9.482				
10,100.0	8,850.0	10,361.1	9,155.0	43.5	43.1	115.03	706.5	-923.1	720.0	641.2	78.72	9.146				
10,200.0	8,850.0	10,461.1	9,155.0	45.2	44.7	115.03	706.0	-1,023.1	720.0	638.3	81.65	8.818				
10,300.0	8,850.0	10,561.1	9,155.0	46.9	46.3	115.03	705.5	-1,123.1	720.0	635.2	84.71	8.499				
10,400.0	8,850.0	10,661.1	9,155.0	48.7	48.0	115.03	705.1	-1,223.1	719.9	632.1	87.89	8.191				
10,500.0	8,850.0	10,761.1	9,155.0	50.5	49.8	115.03	704.6	-1,323.1	719.9	628.8	91.17	7.897				
10,600.0	8,850.0	10,861.1	9,155.0	52.4	51.6	115.03	704.1	-1,423.1	719.9	625.4	94.55	7.615				
10,700.0	8,850.0	10,961.1	9,155.0	54.4	53.5	115.03	703.7	-1,523.1	719.9	621.9	98.01	7.346				
10,800.0	8,850.0	11,061.1	9,155.0	56.3	55.4	115.03	703.2	-1,623.1	719.9	618.4	101.54	7.090				
10,900.0	8,850.0	11,161.1	9,155.0	58.3	57.3	115.03	702.7	-1,723.1	719.9	614.8	105.15	6.847				
11,000.0	8,850.0	11,261.1	9,155.0	60.4	59.3	115.03	702.2	-1,823.1	719.9	611.1	108.81	6.616				
11,100.0	8,850.0	11,361.1	9,155.0	62.4	61.3	115.03	701.8	-1,923.1	719.9	607.4	112.53	6.398				
11,200.0	8,850.0	11,461.1	9,155.0	64.5	63.3	115.03	701.3	-2,023.1	719.9	603.6	116.30	6.190				
11,300.0	8,850.0	11,561.1	9,155.0	66.6	65.4	115.03	700.8	-2,123.1	719.9	599.8	120.11	5.994				
11,400.0	8,850.0	11,661.1	9,155.0	68.8	67.5	115.03	700.3	-2,223.1	719.9	596.0	123.97	5.807				
11,500.0	8,850.0	11,761.1	9,155.0	70.9	69.6	115.03	699.9	-2,323.1	719.9	592.1	127.86	5.631				
11,600.0	8,850.0	11,861.1	9,155.0	73.1	71.7	115.03	699.4	-2,423.1	719.9	588.1	131.78	5.463				
11,700.0	8,850.0	11,961.1	9,155.0	75.2	73.8	115.03	698.9	-2,523.1	719.9	584.2	135.74	5.304				
11,800.0	8,850.0	12,061.1	9,155.0	77.4	76.0	115.03	698.5	-2,623.1	719.9	580.2	139.73	5.152				
11,900.0	8,850.0	12,161.1	9,155.0	79.6	78.2	115.03	698.0	-2,723.1	719.9	576.2	143.74	5.008				
12,000.0	8,850.0	12,261.1	9,155.0	81.9	80.3	115.03	697.5	-2,823.1	719.9	572.1	147.77	4.872				
12,100.0	8,850.0	12,361.1	9,155.0	84.1	82.5	115.03	697.0	-2,923.1	719.9	568.1	151.83	4.742				
12,200.0	8,850.0	12,461.1	9,155.0	86.3	84.8	115.03	696.6	-3,023.1	719.9	564.0	155.91	4.618				
12,300.0	8,850.0	12,561.1	9,155.0	88.6	87.0	115.03	696.1	-3,123.1	719.9	559.9	160.00	4.499				

CC - Min centre to center distance or convergent point, SF - min separation factor, ES - min ellipse separation

Anticollision Report

Company:	NEW MEXICO	Local Co-ordinate Reference	Well KANGAROO 12 FED COM 133H
Project:	(SP) EDDY	TVD Reference:	KB @ 3288.6ft
Reference Site:	KANGAROO 12 FED	MD Reference:	KB @ 3288.6ft
Site Error:	0.0 ft	North Reference:	Grid
Reference Well:	KANGAROO 12 FED COM 133H	Survey Calculation Method:	Minimum Curvature
Well Error:	0.0 ft	Output errors are at	2.00 sigma
Reference Wellbore	OWB	Database:	Compass_17
Reference Design:	PWP0	Offset TVD Reference:	Offset Datum

Offset Design KANGAROO 12 FED - KANGAROO 12 FED COM 203H - OWB - PWP0													Offset Site Error:	0.0 ft		
Survey Program: 0-MWD													Rule Assigned:		Offset Well Error:	0.0 ft
Measured Reference Depth (ft)	Vertical Depth (ft)	Measured Depth (ft)	Vertical Depth (ft)	Semi Major Axis Reference (ft) Offset (ft)		Highside Toolface (°)	Offset Wellbore Centre +N/-S (ft) +E/-W (ft)		Distance Between Centres (ft) Between Ellipses (ft)		Minimum Separation (ft)	Separation Factor	Warning			
12,400.0	8,850.0	12,661.1	9,155.0	90.8	89.2	115.03	695.6	-3,223.1	719.9	555.8	164.11	4.387				
12,500.0	8,850.0	12,761.1	9,155.0	93.1	91.5	115.03	695.1	-3,323.1	719.9	551.6	168.24	4.279				
12,600.0	8,850.0	12,861.1	9,155.0	95.4	93.7	115.03	694.7	-3,423.1	719.9	547.5	172.39	4.176				
12,700.0	8,850.0	12,961.1	9,155.0	97.6	96.0	115.03	694.2	-3,523.1	719.9	543.3	176.54	4.078				
12,800.0	8,850.0	13,061.1	9,155.0	99.9	98.2	115.03	693.7	-3,623.1	719.9	539.2	180.71	3.984				
12,900.0	8,850.0	13,161.1	9,155.0	102.2	100.5	115.03	693.2	-3,723.1	719.9	535.0	184.90	3.893				
13,000.0	8,850.0	13,261.1	9,155.0	104.5	102.8	115.03	692.8	-3,823.1	719.9	530.8	189.09	3.807				
13,100.0	8,850.0	13,361.1	9,155.0	106.8	105.1	115.03	692.3	-3,923.1	719.9	526.6	193.29	3.724				
13,200.0	8,850.0	13,461.1	9,155.0	109.1	107.4	115.03	691.8	-4,023.1	719.9	522.4	197.51	3.645				
13,300.0	8,850.0	13,561.1	9,155.0	111.5	109.7	115.03	691.4	-4,123.1	719.9	518.1	201.73	3.568				
13,400.0	8,850.0	13,661.1	9,155.0	113.8	112.0	115.03	690.9	-4,223.1	719.9	513.9	205.96	3.495				
13,500.0	8,850.0	13,761.1	9,155.0	116.1	114.3	115.03	690.4	-4,323.1	719.9	509.7	210.20	3.425				
13,600.0	8,850.0	13,861.1	9,155.0	118.4	116.6	115.03	689.9	-4,423.1	719.9	505.4	214.45	3.357				
13,700.0	8,850.0	13,961.1	9,155.0	120.7	118.9	115.03	689.5	-4,523.1	719.9	501.1	218.70	3.291				
13,800.0	8,850.0	14,061.1	9,155.0	123.1	121.2	115.03	689.0	-4,623.1	719.8	496.9	222.96	3.229				
13,900.0	8,850.0	14,161.1	9,155.0	125.4	123.5	115.03	688.5	-4,723.1	719.8	492.6	227.23	3.168				
14,000.0	8,850.0	14,261.1	9,155.0	127.8	125.9	115.03	688.0	-4,823.1	719.8	488.3	231.50	3.109				
14,100.0	8,850.0	14,361.1	9,155.0	130.1	128.2	115.03	687.6	-4,923.1	719.8	484.1	235.78	3.053				
14,200.0	8,850.0	14,461.1	9,155.0	132.4	130.5	115.03	687.1	-5,023.1	719.8	479.8	240.07	2.998				
14,300.0	8,850.0	14,561.1	9,155.0	134.8	132.9	115.03	686.6	-5,123.1	719.8	475.5	244.36	2.946				
14,400.0	8,850.0	14,661.1	9,155.0	137.1	135.2	115.03	686.2	-5,223.1	719.8	471.2	248.65	2.895				
14,500.0	8,850.0	14,761.1	9,155.0	139.5	137.6	115.03	685.7	-5,323.1	719.8	466.9	252.95	2.846				
14,600.0	8,850.0	14,861.1	9,155.0	141.8	139.9	115.03	685.2	-5,423.1	719.8	462.6	257.25	2.798				
14,700.0	8,850.0	14,961.1	9,155.0	144.2	142.2	115.03	684.7	-5,523.1	719.8	458.3	261.56	2.752				
14,800.0	8,850.0	15,061.1	9,155.0	146.6	144.6	115.03	684.3	-5,623.1	719.8	453.9	265.87	2.707				
14,900.0	8,850.0	15,161.1	9,155.0	148.9	147.0	115.03	683.8	-5,723.1	719.8	449.6	270.19	2.664				
15,000.0	8,850.0	15,261.1	9,155.0	151.3	149.3	115.03	683.3	-5,823.1	719.8	445.3	274.51	2.622				
15,100.0	8,850.0	15,361.1	9,155.0	153.6	151.7	115.03	682.8	-5,923.1	719.8	441.0	278.83	2.582				
15,200.0	8,850.0	15,461.1	9,155.0	156.0	154.0	115.03	682.4	-6,023.1	719.8	436.7	283.16	2.542				
15,300.0	8,850.0	15,561.1	9,155.0	158.4	156.4	115.04	681.9	-6,123.1	719.8	432.3	287.48	2.504				
15,400.0	8,850.0	15,661.1	9,155.0	160.7	158.7	115.04	681.4	-6,223.1	719.8	428.0	291.82	2.467				
15,500.0	8,850.0	15,761.1	9,155.0	163.1	161.1	115.04	681.0	-6,323.1	719.8	423.6	296.15	2.431				
15,600.0	8,850.0	15,861.1	9,155.0	165.5	163.5	115.04	680.5	-6,423.1	719.8	419.3	300.49	2.395				
15,700.0	8,850.0	15,961.1	9,155.0	167.9	165.8	115.04	680.0	-6,523.1	719.8	415.0	304.83	2.361				
15,800.0	8,850.0	16,061.1	9,155.0	170.2	168.2	115.04	679.5	-6,623.1	719.8	410.6	309.17	2.328				
15,900.0	8,850.0	16,161.1	9,155.0	172.6	170.6	115.04	679.1	-6,723.1	719.8	406.3	313.51	2.296				
16,000.0	8,850.0	16,261.1	9,155.0	175.0	172.9	115.04	678.6	-6,823.1	719.8	401.9	317.86	2.264				
16,100.0	8,850.0	16,361.1	9,155.0	177.4	175.3	115.04	678.1	-6,923.1	719.8	397.6	322.21	2.234				
16,200.0	8,850.0	16,461.1	9,155.0	179.7	177.7	115.04	677.6	-7,023.1	719.8	393.2	326.56	2.204				
16,300.0	8,850.0	16,561.1	9,155.0	182.1	180.1	115.04	677.2	-7,123.1	719.8	388.9	330.91	2.175				
16,400.0	8,850.0	16,661.1	9,155.0	184.5	182.4	115.04	676.7	-7,223.1	719.8	384.5	335.27	2.147				
16,500.0	8,850.0	16,761.1	9,155.0	186.9	184.8	115.04	676.2	-7,323.1	719.8	380.1	339.63	2.119				
16,600.0	8,850.0	16,861.1	9,155.0	189.3	187.2	115.04	675.7	-7,423.1	719.8	375.8	343.98	2.092				
16,660.7	8,850.0	16,921.8	9,155.0	190.7	188.6	115.04	675.5	-7,483.8	719.8	373.1	346.63	2.076				
16,672.6	8,850.0	16,921.8	9,155.0	191.0	188.6	115.04	675.5	-7,483.8	719.9	373.0	346.91	2.075 SF				

CC - Min centre to center distance or convergent point, SF - min separation factor, ES - min ellipse separation

Anticollision Report

Company:	NEW MEXICO	Local Co-ordinate Reference	Well KANGAROO 12 FED COM 133H
Project:	(SP) EDDY	TVD Reference:	KB @ 3288.6ft
Reference Site:	KANGAROO 12 FED	MD Reference:	KB @ 3288.6ft
Site Error:	0.0 ft	North Reference:	Grid
Reference Well:	KANGAROO 12 FED COM 133H	Survey Calculation Method:	Minimum Curvature
Well Error:	0.0 ft	Output errors are at	2.00 sigma
Reference Wellbore	OWB	Database:	Compass_17
Reference Design:	PWP0	Offset TVD Reference:	Offset Datum

Offset Design KANGAROO 12 FED - KANGAROO 12 FED COM 204H - OWB - PWP0													Offset Site Error:	0.0 ft
Survey Program: 0-MWD													Offset Well Error:	0.0 ft
Reference	Vertical	Offset	Vertical	Semi Major Axis		Highside Toolface (°)	Offset Wellbore Centre		Distance		Minimum Separation (ft)	Separation Factor	Warning	
Measured Depth (ft)	Depth (ft)	Measured Depth (ft)	Depth (ft)	Reference (ft)	Offset (ft)		+N/-S (ft)	+E/-W (ft)	Between Centres (ft)	Between Ellipses (ft)				
0.0	0.0	0.8	0.8	0.0	0.0	-90.12	-0.2	-99.0	99.0					
100.0	100.0	100.8	100.8	0.3	0.3	-90.12	-0.2	-99.0	99.0	98.5	0.50	196.106		
200.0	200.0	200.8	200.8	0.6	0.6	-90.12	-0.2	-99.0	99.0	97.8	1.22	81.020		
300.0	300.0	300.8	300.8	1.0	1.0	-90.12	-0.2	-99.0	99.0	97.0	1.94	51.057		
400.0	400.0	400.8	400.8	1.3	1.3	-90.12	-0.2	-99.0	99.0	96.3	2.66	37.273		
500.0	500.0	500.8	500.8	1.7	1.7	-90.12	-0.2	-99.0	99.0	95.6	3.37	29.349		
600.0	600.0	600.8	600.8	2.0	2.0	-90.12	-0.2	-99.0	99.0	94.9	4.09	24.204		
700.0	700.0	700.8	700.8	2.4	2.4	-90.12	-0.2	-99.0	99.0	94.2	4.81	20.594		
800.0	800.0	800.8	800.8	2.8	2.8	-90.12	-0.2	-99.0	99.0	93.5	5.52	17.920		
900.0	900.0	900.8	900.8	3.1	3.1	-90.12	-0.2	-99.0	99.0	92.7	6.24	15.862		
1,000.0	1,000.0	1,000.8	1,000.8	3.5	3.5	-90.12	-0.2	-99.0	99.0	92.0	6.96	14.227		
1,100.0	1,100.0	1,100.8	1,100.8	3.8	3.8	-90.12	-0.2	-99.0	99.0	91.3	7.67	12.898		
1,200.0	1,200.0	1,200.8	1,200.8	4.2	4.2	-90.12	-0.2	-99.0	99.0	90.6	8.39	11.796		
1,300.0	1,300.0	1,300.8	1,300.8	4.6	4.6	-90.12	-0.2	-99.0	99.0	89.9	9.11	10.867		
1,400.0	1,400.0	1,400.8	1,400.8	4.9	4.9	-90.12	-0.2	-99.0	99.0	89.2	9.82	10.074		
1,500.0	1,500.0	1,500.8	1,500.8	5.3	5.3	-90.12	-0.2	-99.0	99.0	88.4	10.54	9.389		
1,600.0	1,600.0	1,600.8	1,600.8	5.6	5.6	-90.12	-0.2	-99.0	99.0	87.7	11.26	8.791		
1,700.0	1,700.0	1,700.8	1,700.8	6.0	6.0	-90.12	-0.2	-99.0	99.0	87.0	11.98	8.265		
1,800.0	1,800.0	1,800.8	1,800.8	6.3	6.3	-90.12	-0.2	-99.0	99.0	86.3	12.69	7.798		
1,900.0	1,900.0	1,900.8	1,900.8	6.7	6.7	-90.12	-0.2	-99.0	99.0	85.6	13.41	7.381		
2,000.0	2,000.0	2,000.8	2,000.8	7.1	7.1	-90.12	-0.2	-99.0	99.0	84.9	14.13	7.007 CC		
2,004.5	2,004.5	2,005.4	2,005.4	7.1	7.1	-173.10	-0.2	-99.0	99.0	84.8	14.16	6.991 ES		
2,100.0	2,100.0	2,102.8	2,102.8	7.4	7.4	-174.09	-1.7	-97.9	99.7	84.9	14.82	6.726		
2,200.0	2,199.8	2,204.5	2,204.4	7.8	7.7	-176.95	-6.2	-94.8	102.1	86.6	15.49	6.588		
2,300.0	2,299.5	2,305.9	2,305.3	8.1	8.1	178.62	-13.6	-89.7	106.5	90.4	16.17	6.589		
2,400.0	2,398.7	2,406.6	2,405.3	8.5	8.4	173.09	-23.9	-82.6	113.7	96.9	16.85	6.749		
2,500.0	2,497.5	2,506.5	2,503.9	8.8	8.8	167.04	-36.9	-73.6	124.3	106.8	17.55	7.082		
2,600.0	2,595.9	2,604.9	2,600.7	9.2	9.1	161.68	-51.0	-63.9	137.4	119.1	18.26	7.523		
2,700.0	2,694.4	2,703.3	2,697.6	9.6	9.5	157.27	-65.0	-54.1	151.5	132.5	18.98	7.978		
2,800.0	2,792.9	2,801.6	2,794.5	10.0	9.9	153.61	-79.1	-44.4	166.3	146.6	19.71	8.434		
2,900.0	2,891.4	2,900.0	2,891.4	10.4	10.2	150.56	-93.1	-34.7	181.6	161.2	20.45	8.880		
3,000.0	2,989.9	2,998.4	2,988.3	10.7	10.6	147.99	-107.2	-25.0	197.4	176.2	21.20	9.312		
3,100.0	3,088.4	3,096.8	3,085.2	11.1	11.0	145.80	-121.2	-15.3	213.6	191.6	21.96	9.725		
3,200.0	3,186.8	3,195.2	3,182.1	11.6	11.4	143.92	-135.3	-5.5	229.9	207.2	22.72	10.119		
3,300.0	3,285.3	3,293.6	3,279.0	12.0	11.8	142.29	-149.3	4.2	246.6	223.1	23.50	10.494		
3,400.0	3,383.8	3,391.9	3,375.9	12.4	12.2	140.86	-163.4	13.9	263.3	239.1	24.27	10.848		
3,500.0	3,482.3	3,490.3	3,472.8	12.8	12.6	139.61	-177.4	23.6	280.2	255.2	25.06	11.184		
3,600.0	3,580.8	3,588.7	3,569.6	13.2	13.0	138.49	-191.5	33.3	297.3	271.4	25.84	11.502		
3,700.0	3,679.2	3,687.1	3,666.5	13.6	13.4	137.50	-205.5	43.1	314.4	287.8	26.64	11.803		
3,800.0	3,777.7	3,785.5	3,763.4	14.0	13.8	136.61	-219.6	52.8	331.6	304.2	27.43	12.087		
3,900.0	3,876.2	3,883.9	3,860.3	14.5	14.2	135.81	-233.6	62.5	348.9	320.6	28.23	12.357		
4,000.0	3,974.7	3,982.3	3,957.2	14.9	14.6	135.09	-247.7	72.2	366.2	337.2	29.04	12.611		
4,100.0	4,073.2	4,080.6	4,054.1	15.3	15.0	134.43	-261.7	81.9	383.6	353.8	29.85	12.853		
4,200.0	4,171.6	4,179.0	4,151.0	15.7	15.5	133.82	-275.8	91.7	401.0	370.4	30.66	13.082		
4,300.0	4,270.1	4,277.4	4,247.9	16.2	15.9	133.27	-289.8	101.4	418.5	387.0	31.47	13.299		
4,400.0	4,368.6	4,375.8	4,344.8	16.6	16.3	132.76	-303.9	111.1	436.0	403.7	32.28	13.506		
4,500.0	4,467.1	4,474.2	4,441.7	17.0	16.7	132.29	-317.9	120.8	453.6	420.5	33.10	13.702		
4,600.0	4,565.6	4,572.6	4,538.5	17.5	17.1	131.86	-332.0	130.5	471.1	437.2	33.92	13.888		
4,700.0	4,664.0	4,670.9	4,635.4	17.9	17.6	131.46	-346.0	140.3	488.7	454.0	34.74	14.066		
4,800.0	4,762.5	4,769.3	4,732.3	18.3	18.0	131.08	-360.1	150.0	506.3	470.8	35.57	14.235		
4,864.5	4,826.0	4,832.7	4,794.8	18.6	18.3	130.85	-369.1	156.3	517.7	481.6	36.10	14.340		

CC - Min centre to center distance or convergent point, SF - min separation factor, ES - min ellipse separation

Anticollision Report

Company:	NEW MEXICO	Local Co-ordinate Reference	Well KANGAROO 12 FED COM 133H
Project:	(SP) EDDY	TVD Reference:	KB @ 3288.6ft
Reference Site:	KANGAROO 12 FED	MD Reference:	KB @ 3288.6ft
Site Error:	0.0 ft	North Reference:	Grid
Reference Well:	KANGAROO 12 FED COM 133H	Survey Calculation Method:	Minimum Curvature
Well Error:	0.0 ft	Output errors are at	2.00 sigma
Reference Wellbore	OWB	Database:	Compass_17
Reference Design:	PWP0	Offset TVD Reference:	Offset Datum

Offset Design KANGAROO 12 FED - KANGAROO 12 FED COM 204H - OWB - PWP0													Offset Site Error:	0.0 ft		
Survey Program: 0-MWD													Rule Assigned:		Offset Well Error:	0.0 ft
Measured Depth (ft)	Vertical Depth (ft)	Offset		Semi Major Axis		Highside Toolface (°)	Offset Wellbore Centre		Distance		Minimum Separation (ft)	Separation Factor	Warning			
		Measured Depth (ft)	Vertical Depth (ft)	Reference (ft)	Offset (ft)		+N/-S (ft)	+E/-W (ft)	Between Centres (ft)	Between Ellipses (ft)						
4,900.0	4,861.0	4,867.7	4,829.2	18.8	18.4	130.81	-374.1	159.7	523.8	487.4	36.39	14.393				
5,000.0	4,960.0	4,966.3	4,926.3	19.2	18.9	130.48	-388.2	169.5	539.6	502.3	37.21	14.501				
5,100.0	5,059.4	5,065.1	5,023.6	19.6	19.3	129.87	-402.3	179.2	553.1	515.1	38.01	14.551				
5,200.0	5,159.1	5,163.9	5,120.9	19.9	19.7	129.00	-416.4	189.0	564.7	525.9	38.80	14.552				
5,300.0	5,259.0	5,262.6	5,218.1	20.3	20.2	127.88	-430.5	198.7	574.2	534.6	39.57	14.510				
5,364.5	5,323.5	5,326.2	5,280.7	20.5	20.4	-150.00	-439.6	205.0	579.4	539.4	40.06	14.465				
5,400.0	5,359.0	5,361.2	5,315.2	20.6	20.6	-150.54	-444.6	208.5	582.1	541.8	40.32	14.437				
5,500.0	5,459.0	5,459.6	5,412.1	21.0	21.0	-152.04	-458.6	218.2	590.0	548.9	41.06	14.368				
5,600.0	5,559.0	5,558.1	5,509.1	21.3	21.5	-153.50	-472.7	227.9	598.3	556.5	41.80	14.312				
5,700.0	5,659.0	5,656.6	5,606.1	21.6	21.9	-154.92	-486.8	237.7	606.9	564.4	42.53	14.269				
5,800.0	5,759.0	5,755.1	5,703.1	21.9	22.3	-156.30	-500.8	247.4	616.0	572.7	43.26	14.237				
5,900.0	5,859.0	5,853.6	5,800.1	22.3	22.8	-157.64	-514.9	257.1	625.3	581.3	43.99	14.216				
6,000.0	5,959.0	5,952.1	5,897.1	22.6	23.2	-158.94	-529.0	266.8	635.1	590.3	44.71	14.203				
6,100.0	6,059.0	6,050.5	5,994.1	22.9	23.6	-160.20	-543.0	276.6	645.1	599.7	45.43	14.200				
6,200.0	6,159.0	6,149.0	6,091.0	23.3	24.1	-161.43	-557.1	286.3	655.4	609.3	46.15	14.203				
6,300.0	6,259.0	6,247.5	6,188.0	23.6	24.5	-162.61	-571.1	296.0	666.1	619.2	46.86	14.214				
6,400.0	6,359.0	6,363.1	6,302.3	23.9	25.0	-163.81	-585.8	306.2	675.7	628.0	47.71	14.163				
6,500.0	6,459.0	6,480.2	6,418.6	24.3	25.5	-164.68	-596.8	313.8	683.0	634.5	48.53	14.073				
6,600.0	6,559.0	6,598.3	6,536.3	24.6	25.9	-165.23	-603.9	318.7	687.8	638.5	49.32	13.946				
6,700.0	6,659.0	6,716.8	6,654.8	24.9	26.3	-165.47	-607.0	320.8	689.8	639.8	50.06	13.781				
6,800.0	6,759.0	6,821.8	6,759.8	25.3	26.6	-165.48	-607.1	320.9	689.9	639.2	50.72	13.602				
6,900.0	6,859.0	6,921.8	6,859.8	25.6	26.9	-165.48	-607.1	320.9	689.9	638.6	51.38	13.428				
7,000.0	6,959.0	7,021.8	6,959.8	25.9	27.2	-165.48	-607.1	320.9	689.9	637.9	52.04	13.259				
7,100.0	7,059.0	7,121.8	7,059.8	26.3	27.5	-165.48	-607.1	320.9	689.9	637.3	52.69	13.093				
7,200.0	7,159.0	7,221.8	7,159.8	26.6	27.9	-165.48	-607.1	320.9	689.9	636.6	53.35	12.931				
7,300.0	7,259.0	7,321.8	7,259.8	27.0	28.2	-165.48	-607.1	320.9	689.9	635.9	54.02	12.773				
7,400.0	7,359.0	7,421.8	7,359.8	27.3	28.5	-165.48	-607.1	320.9	689.9	635.3	54.68	12.618				
7,500.0	7,459.0	7,521.8	7,459.8	27.6	28.8	-165.48	-607.1	320.9	689.9	634.6	55.34	12.467				
7,600.0	7,559.0	7,621.8	7,559.8	28.0	29.1	-165.48	-607.1	320.9	689.9	633.9	56.01	12.319				
7,700.0	7,659.0	7,721.8	7,659.8	28.3	29.4	-165.48	-607.1	320.9	689.9	633.3	56.67	12.174				
7,800.0	7,759.0	7,821.8	7,759.8	28.7	29.7	-165.48	-607.1	320.9	689.9	632.6	57.34	12.032				
7,900.0	7,859.0	7,921.8	7,859.8	29.0	30.0	-165.48	-607.1	320.9	689.9	631.9	58.01	11.893				
8,000.0	7,959.0	8,021.8	7,959.8	29.4	30.4	-165.48	-607.1	320.9	689.9	631.3	58.68	11.757				
8,100.0	8,059.0	8,121.8	8,059.8	29.7	30.7	-165.48	-607.1	320.9	689.9	630.6	59.35	11.624				
8,200.0	8,159.0	8,221.8	8,159.8	30.0	31.0	-165.48	-607.1	320.9	689.9	629.9	60.03	11.494				
8,300.0	8,259.0	8,321.8	8,259.8	30.4	31.3	-165.48	-607.1	320.9	689.9	629.2	60.70	11.367				
8,400.0	8,359.0	8,421.8	8,359.8	30.7	31.6	-165.48	-607.1	320.9	689.9	628.6	61.37	11.242				
8,413.5	8,372.5	8,435.3	8,373.3	30.8	31.7	-165.48	-607.1	320.9	689.9	628.5	61.46	11.225				
8,425.0	8,384.0	8,446.8	8,384.8	30.8	31.7	-75.23	-607.1	320.9	689.9	628.4	61.54	11.211				
8,450.0	8,409.0	8,471.8	8,409.8	30.9	31.8	-75.36	-607.1	320.9	689.6	627.9	61.70	11.177				
8,475.0	8,433.8	8,496.7	8,434.6	31.0	31.9	-75.64	-607.1	320.9	688.9	627.1	61.85	11.139				
8,500.0	8,458.5	8,521.4	8,459.3	31.0	31.9	-76.06	-607.1	320.9	688.0	626.0	61.99	11.098				
8,525.0	8,483.0	8,545.8	8,483.8	31.1	32.0	-76.62	-607.1	320.9	686.8	624.6	62.13	11.053				
8,550.0	8,507.2	8,570.0	8,508.0	31.2	32.1	-77.30	-607.1	320.9	685.3	623.0	62.26	11.006				
8,575.0	8,530.9	8,593.8	8,531.7	31.2	32.2	-78.10	-607.1	320.9	683.5	621.2	62.39	10.957				
8,600.0	8,554.3	8,617.1	8,555.1	31.3	32.3	-79.01	-607.1	320.9	681.7	619.2	62.50	10.906				
8,625.0	8,577.2	8,640.0	8,578.0	31.3	32.3	-80.01	-607.1	320.9	679.6	617.0	62.61	10.855				
8,650.0	8,599.5	8,662.3	8,600.3	31.4	32.4	-81.10	-607.1	320.9	677.6	614.9	62.71	10.805				
8,675.0	8,621.1	8,684.0	8,621.9	31.4	32.5	-82.25	-607.1	320.9	675.5	612.7	62.80	10.756				
8,700.0	8,642.1	8,704.9	8,642.9	31.5	32.5	-83.46	-607.1	320.9	673.5	610.6	62.89	10.709				
8,725.0	8,662.4	8,725.2	8,663.2	31.5	32.6	-84.69	-607.1	320.9	671.6	608.7	62.97	10.666				

CC - Min centre to center distance or convergent point, SF - min separation factor, ES - min ellipse separation

Anticollision Report

Company:	NEW MEXICO	Local Co-ordinate Reference	Well KANGAROO 12 FED COM 133H
Project:	(SP) EDDY	TVD Reference:	KB @ 3288.6ft
Reference Site:	KANGAROO 12 FED	MD Reference:	KB @ 3288.6ft
Site Error:	0.0 ft	North Reference:	Grid
Reference Well:	KANGAROO 12 FED COM 133H	Survey Calculation Method:	Minimum Curvature
Well Error:	0.0 ft	Output errors are at	2.00 sigma
Reference Wellbore	OWB	Database:	Compass_17
Reference Design:	PWP0	Offset TVD Reference:	Offset Datum

Offset Design KANGAROO 12 FED - KANGAROO 12 FED COM 204H - OWB - PWP0													Offset Site Error:	0.0 ft		
Survey Program: 0-MWD													Rule Assigned:		Offset Well Error:	0.0 ft
Measured Depth (ft)	Vertical Reference Depth (ft)	Offset		Semi Major Axis		Highside Toolface (°)	Offset Wellbore Centre		Distance		Minimum Separation (ft)	Separation Factor	Warning			
		Measured Depth (ft)	Vertical Depth (ft)	Reference (ft)	Offset (ft)		+N/-S (ft)	+E/-W (ft)	Between Centres (ft)	Between Ellipses (ft)						
8,750.0	8,681.8	8,744.1	8,682.0	31.6	32.7	-85.89	-607.1	320.9	670.0	607.0	63.04	10.628				
8,775.0	8,700.5	8,761.2	8,699.2	31.6	32.7	-87.00	-607.1	320.4	668.7	605.6	63.10	10.597				
8,800.0	8,718.2	8,778.6	8,716.5	31.7	32.8	-88.09	-607.1	319.3	667.8	604.6	63.16	10.572				
8,825.0	8,734.9	8,796.3	8,734.2	31.7	32.8	-89.18	-607.1	317.5	667.2	604.0	63.22	10.554				
8,844.1	8,747.0	8,810.1	8,747.8	31.8	32.9	-90.00	-607.1	315.7	667.1	603.8	63.26	10.545				
8,850.0	8,750.7	8,814.5	8,752.1	31.8	32.9	-90.25	-607.1	315.1	667.1	603.8	63.27	10.543				
8,875.0	8,765.4	8,833.0	8,770.4	31.8	32.9	-91.32	-607.2	311.8	667.4	604.1	63.33	10.540				
8,900.0	8,779.1	8,852.0	8,789.0	31.9	33.0	-92.37	-607.2	307.7	668.2	604.8	63.38	10.544				
8,925.0	8,791.6	8,871.6	8,807.9	31.9	33.0	-93.40	-607.2	302.8	669.5	606.1	63.42	10.556				
8,950.0	8,803.0	8,891.8	8,827.2	32.0	33.1	-94.43	-607.2	296.9	671.2	607.8	63.46	10.578				
8,975.0	8,813.3	8,912.7	8,846.9	32.1	33.1	-95.45	-607.3	289.9	673.5	610.0	63.49	10.608				
9,000.0	8,822.3	8,934.5	8,867.1	32.2	33.2	-96.47	-607.3	281.7	676.2	612.7	63.50	10.649				
9,025.0	8,830.0	8,957.2	8,887.7	32.2	33.2	-97.49	-607.4	272.2	679.5	616.0	63.50	10.701				
9,050.0	8,836.6	8,981.0	8,908.8	32.3	33.2	-98.52	-607.4	261.1	683.2	619.8	63.47	10.765				
9,075.0	8,841.8	9,006.2	8,930.6	32.4	33.3	-99.56	-607.5	248.4	687.4	624.0	63.41	10.841				
9,100.0	8,845.8	9,033.0	8,952.9	32.5	33.3	-100.64	-607.5	233.5	692.1	628.8	63.31	10.931				
9,125.0	8,848.4	9,061.7	8,975.8	32.7	33.4	-101.76	-607.6	216.3	697.2	634.0	63.17	11.036				
9,150.0	8,849.8	9,092.7	8,999.4	32.8	33.4	-102.94	-607.7	196.1	702.7	639.7	62.98	11.157				
9,163.5	8,850.0	9,110.6	9,012.3	32.8	33.4	-103.61	-607.8	183.9	705.8	642.9	62.86	11.228				
9,200.0	8,850.0	9,165.6	9,049.3	33.0	33.5	-106.57	-608.0	143.1	714.2	651.7	62.45	11.436				
9,300.0	8,850.0	9,369.8	9,139.9	33.7	33.5	-113.43	-608.8	-38.1	731.3	669.7	61.60	11.872				
9,400.0	8,850.0	9,549.9	9,155.0	34.5	33.8	-114.51	-609.7	-216.9	733.2	670.3	62.86	11.664				
9,500.0	8,850.0	9,649.9	9,155.0	35.4	34.4	-114.51	-610.2	-316.9	733.2	668.9	64.31	11.401				
9,600.0	8,850.0	9,749.9	9,155.0	36.5	35.2	-114.51	-610.6	-416.9	733.2	667.2	66.04	11.103				
9,700.0	8,850.0	9,849.9	9,155.0	37.7	36.2	-114.51	-611.1	-516.9	733.2	665.2	68.01	10.781				
9,800.0	8,850.0	9,949.9	9,155.0	39.0	37.3	-114.51	-611.6	-616.9	733.2	663.0	70.21	10.444				
9,900.0	8,850.0	10,049.9	9,155.0	40.4	38.6	-114.51	-612.1	-716.9	733.2	660.6	72.61	10.098				
10,000.0	8,850.0	10,149.9	9,155.0	41.9	39.9	-114.51	-612.5	-816.9	733.2	658.0	75.21	9.750				
10,100.0	8,850.0	10,249.9	9,155.0	43.5	41.4	-114.51	-613.0	-916.9	733.2	655.3	77.97	9.405				
10,200.0	8,850.0	10,349.9	9,155.0	45.2	42.9	-114.51	-613.5	-1,016.9	733.2	652.4	80.88	9.066				
10,300.0	8,850.0	10,449.9	9,155.0	46.9	44.5	-114.51	-614.0	-1,116.9	733.3	649.3	83.93	8.737				
10,400.0	8,850.0	10,549.9	9,155.0	48.7	46.2	-114.51	-614.4	-1,216.9	733.3	646.2	87.10	8.419				
10,500.0	8,850.0	10,649.9	9,155.0	50.5	47.9	-114.51	-614.9	-1,316.9	733.3	642.9	90.38	8.113				
10,600.0	8,850.0	10,749.9	9,155.0	52.4	49.7	-114.51	-615.4	-1,416.9	733.3	639.5	93.75	7.821				
10,700.0	8,850.0	10,849.9	9,155.0	54.4	51.5	-114.51	-615.9	-1,516.9	733.3	636.1	97.21	7.543				
10,800.0	8,850.0	10,949.9	9,155.0	56.3	53.4	-114.51	-616.3	-1,616.9	733.3	632.5	100.75	7.278				
10,900.0	8,850.0	11,049.9	9,155.0	58.3	55.4	-114.51	-616.8	-1,716.9	733.3	628.9	104.37	7.026				
11,000.0	8,850.0	11,149.9	9,155.0	60.4	57.3	-114.51	-617.3	-1,816.9	733.3	625.3	108.04	6.787				
11,100.0	8,850.0	11,249.9	9,155.0	62.4	59.3	-114.51	-617.8	-1,916.9	733.3	621.5	111.77	6.561				
11,200.0	8,850.0	11,349.9	9,155.0	64.5	61.3	-114.51	-618.2	-2,016.9	733.3	617.7	115.55	6.346				
11,300.0	8,850.0	11,449.9	9,155.0	66.6	63.4	-114.51	-618.7	-2,116.9	733.3	613.9	119.38	6.143				
11,400.0	8,850.0	11,549.9	9,155.0	68.8	65.5	-114.51	-619.2	-2,216.9	733.3	610.1	123.25	5.950				
11,500.0	8,850.0	11,649.9	9,155.0	70.9	67.6	-114.51	-619.7	-2,316.9	733.3	606.2	127.16	5.767				
11,600.0	8,850.0	11,749.9	9,155.0	73.1	69.7	-114.51	-620.1	-2,416.9	733.3	602.2	131.10	5.594				
11,700.0	8,850.0	11,849.9	9,155.0	75.2	71.9	-114.51	-620.6	-2,516.8	733.3	598.2	135.08	5.429				
11,800.0	8,850.0	11,949.9	9,155.0	77.4	74.0	-114.51	-621.1	-2,616.8	733.3	594.2	139.08	5.273				
11,900.0	8,850.0	12,049.9	9,155.0	79.6	76.2	-114.51	-621.6	-2,716.8	733.3	590.2	143.11	5.124				
12,000.0	8,850.0	12,149.9	9,155.0	81.9	78.4	-114.51	-622.0	-2,816.8	733.3	586.2	147.17	4.983				
12,100.0	8,850.0	12,249.9	9,155.0	84.1	80.6	-114.51	-622.5	-2,916.8	733.3	582.1	151.24	4.849				
12,200.0	8,850.0	12,349.9	9,155.0	86.3	82.8	-114.51	-623.0	-3,016.8	733.4	578.0	155.34	4.721				
12,300.0	8,850.0	12,449.9	9,155.0	88.6	85.0	-114.51	-623.5	-3,116.8	733.4	573.9	159.46	4.599				

CC - Min centre to center distance or convergent point, SF - min separation factor, ES - min ellipse separation

Anticollision Report

Company:	NEW MEXICO	Local Co-ordinate Reference	Well KANGAROO 12 FED COM 133H
Project:	(SP) EDDY	TVD Reference:	KB @ 3288.6ft
Reference Site:	KANGAROO 12 FED	MD Reference:	KB @ 3288.6ft
Site Error:	0.0 ft	North Reference:	Grid
Reference Well:	KANGAROO 12 FED COM 133H	Survey Calculation Method:	Minimum Curvature
Well Error:	0.0 ft	Output errors are at	2.00 sigma
Reference Wellbore	OWB	Database:	Compass_17
Reference Design:	PWP0	Offset TVD Reference:	Offset Datum

Offset Design KANGAROO 12 FED - KANGAROO 12 FED COM 204H - OWB - PWP0													Offset Site Error:	0.0 ft		
Survey Program: 0-MWD													Rule Assigned:		Offset Well Error:	0.0 ft
Measured Depth (ft)	Vertical Reference Depth (ft)	Measured Depth (ft)	Vertical Offset Depth (ft)	Semi Major Axis		Highside Toolface (°)	Offset Wellbore Centre		Distance		Minimum Separation (ft)	Separation Factor	Warning			
				Reference (ft)	Offset (ft)		+N/-S (ft)	+E/-W (ft)	Between Centres (ft)	Between Ellipses (ft)						
12,400.0	8,850.0	12,549.9	9,155.0	90.8	87.3	-114.51	-623.9	-3,216.8	733.4	569.8	163.59	4.483				
12,500.0	8,850.0	12,649.9	9,155.0	93.1	89.5	-114.51	-624.4	-3,316.8	733.4	565.6	167.75	4.372				
12,600.0	8,850.0	12,749.9	9,155.0	95.4	91.8	-114.51	-624.9	-3,416.8	733.4	561.5	171.91	4.266				
12,700.0	8,850.0	12,849.9	9,155.0	97.6	94.0	-114.51	-625.4	-3,516.8	733.4	557.3	176.09	4.165				
12,800.0	8,850.0	12,949.9	9,155.0	99.9	96.3	-114.51	-625.8	-3,616.8	733.4	553.1	180.29	4.068				
12,900.0	8,850.0	13,049.9	9,155.0	102.2	98.6	-114.51	-626.3	-3,716.8	733.4	548.9	184.49	3.975				
13,000.0	8,850.0	13,149.9	9,155.0	104.5	100.8	-114.51	-626.8	-3,816.8	733.4	544.7	188.71	3.886				
13,100.0	8,850.0	13,249.9	9,155.0	106.8	103.1	-114.51	-627.3	-3,916.8	733.4	540.5	192.94	3.801				
13,200.0	8,850.0	13,349.9	9,155.0	109.1	105.4	-114.51	-627.7	-4,016.8	733.4	536.2	197.17	3.720				
13,300.0	8,850.0	13,449.9	9,155.0	111.5	107.7	-114.51	-628.2	-4,116.8	733.4	532.0	201.42	3.641				
13,400.0	8,850.0	13,549.9	9,155.0	113.8	110.0	-114.50	-628.7	-4,216.8	733.4	527.7	205.68	3.566				
13,500.0	8,850.0	13,649.9	9,155.0	116.1	112.3	-114.50	-629.2	-4,316.8	733.4	523.5	209.94	3.493				
13,600.0	8,850.0	13,749.9	9,155.0	118.4	114.7	-114.50	-629.6	-4,416.8	733.4	519.2	214.21	3.424				
13,700.0	8,850.0	13,849.9	9,155.0	120.7	117.0	-114.50	-630.1	-4,516.8	733.4	514.9	218.49	3.357				
13,800.0	8,850.0	13,949.9	9,155.0	123.1	119.3	-114.50	-630.6	-4,616.8	733.4	510.7	222.77	3.292				
13,900.0	8,850.0	14,049.9	9,155.0	125.4	121.6	-114.50	-631.1	-4,716.8	733.4	506.4	227.07	3.230				
14,000.0	8,850.0	14,149.9	9,155.0	127.8	124.0	-114.50	-631.5	-4,816.8	733.4	502.1	231.36	3.170				
14,100.0	8,850.0	14,249.9	9,155.0	130.1	126.3	-114.50	-632.0	-4,916.8	733.5	497.8	235.67	3.112				
14,200.0	8,850.0	14,349.9	9,155.0	132.4	128.6	-114.50	-632.5	-5,016.8	733.5	493.5	239.98	3.056				
14,300.0	8,850.0	14,449.9	9,155.0	134.8	131.0	-114.50	-633.0	-5,116.8	733.5	489.2	244.29	3.002				
14,400.0	8,850.0	14,549.9	9,155.0	137.1	133.3	-114.50	-633.4	-5,216.8	733.5	484.9	248.61	2.950				
14,500.0	8,850.0	14,649.9	9,155.0	139.5	135.7	-114.50	-633.9	-5,316.8	733.5	480.5	252.93	2.900				
14,600.0	8,850.0	14,749.9	9,155.0	141.8	138.0	-114.50	-634.4	-5,416.8	733.5	476.2	257.26	2.851				
14,700.0	8,850.0	14,849.9	9,155.0	144.2	140.3	-114.50	-634.9	-5,516.8	733.5	471.9	261.60	2.804				
14,800.0	8,850.0	14,949.9	9,155.0	146.6	142.7	-114.50	-635.4	-5,616.8	733.5	467.6	265.93	2.758				
14,900.0	8,850.0	15,049.9	9,155.0	148.9	145.1	-114.50	-635.8	-5,716.8	733.5	463.2	270.27	2.714				
15,000.0	8,850.0	15,149.9	9,155.0	151.3	147.4	-114.50	-636.3	-5,816.8	733.5	458.9	274.62	2.671				
15,100.0	8,850.0	15,249.9	9,155.0	153.6	149.8	-114.50	-636.8	-5,916.8	733.5	454.5	278.96	2.629				
15,200.0	8,850.0	15,349.9	9,155.0	156.0	152.1	-114.50	-637.3	-6,016.8	733.5	450.2	283.31	2.589				
15,300.0	8,850.0	15,449.9	9,155.0	158.4	154.5	-114.50	-637.7	-6,116.8	733.5	445.8	287.67	2.550				
15,400.0	8,850.0	15,549.9	9,155.0	160.7	156.9	-114.50	-638.2	-6,216.8	733.5	441.5	292.02	2.512				
15,500.0	8,850.0	15,649.9	9,155.0	163.1	159.2	-114.50	-638.7	-6,316.8	733.5	437.1	296.38	2.475				
15,600.0	8,850.0	15,749.9	9,155.0	165.5	161.6	-114.50	-639.2	-6,416.8	733.5	432.8	300.75	2.439				
15,700.0	8,850.0	15,849.9	9,155.0	167.9	164.0	-114.50	-639.6	-6,516.8	733.5	428.4	305.11	2.404				
15,800.0	8,850.0	15,949.9	9,155.0	170.2	166.3	-114.50	-640.1	-6,616.8	733.5	424.1	309.48	2.370				
15,900.0	8,850.0	16,049.9	9,155.0	172.6	168.7	-114.50	-640.6	-6,716.8	733.5	419.7	313.85	2.337				
16,000.0	8,850.0	16,149.9	9,155.0	175.0	171.1	-114.50	-641.1	-6,816.8	733.6	415.3	318.22	2.305				
16,100.0	8,850.0	16,249.9	9,155.0	177.4	173.4	-114.50	-641.5	-6,916.8	733.6	411.0	322.60	2.274				
16,200.0	8,850.0	16,349.9	9,155.0	179.7	175.8	-114.50	-642.0	-7,016.8	733.6	406.6	326.97	2.243				
16,300.0	8,850.0	16,449.9	9,155.0	182.1	178.2	-114.50	-642.5	-7,116.8	733.6	402.2	331.35	2.214				
16,400.0	8,850.0	16,549.9	9,155.0	184.5	180.6	-114.50	-643.0	-7,216.8	733.6	397.8	335.73	2.185				
16,500.0	8,850.0	16,649.9	9,155.0	186.9	182.9	-114.50	-643.4	-7,316.8	733.6	393.5	340.11	2.157				
16,600.0	8,850.0	16,749.9	9,155.0	189.3	185.3	-114.50	-643.9	-7,416.8	733.6	389.1	344.50	2.129				
16,672.6	8,850.0	16,822.5	9,155.0	191.0	187.1	-114.50	-644.3	-7,489.4	733.6	385.9	347.68	2.110 SF				

CC - Min centre to center distance or convergent point, SF - min separation factor, ES - min ellipse separation

Anticollision Report

Company:	NEW MEXICO	Local Co-ordinate Reference	Well KANGAROO 12 FED COM 133H
Project:	(SP) EDDY	TVD Reference:	KB @ 3288.6ft
Reference Site:	KANGAROO 12 FED	MD Reference:	KB @ 3288.6ft
Site Error:	0.0 ft	North Reference:	Grid
Reference Well:	KANGAROO 12 FED COM 133H	Survey Calculation Method:	Minimum Curvature
Well Error:	0.0 ft	Output errors are at	2.00 sigma
Reference Wellbore	OWB	Database:	Compass_17
Reference Design:	PWP0	Offset TVD Reference:	Offset Datum

Reference Depths are relative to KB @ 3288.6ft
 Offset Depths are relative to Offset Datum
 Central Meridian is 104° 20' 0.000 W

Coordinates are relative to: KANGAROO 12 FED COM 133H
 Coordinate System is US State Plane 1983, New Mexico Eastern Zone
 Grid Convergence at Surface is: 0.11°

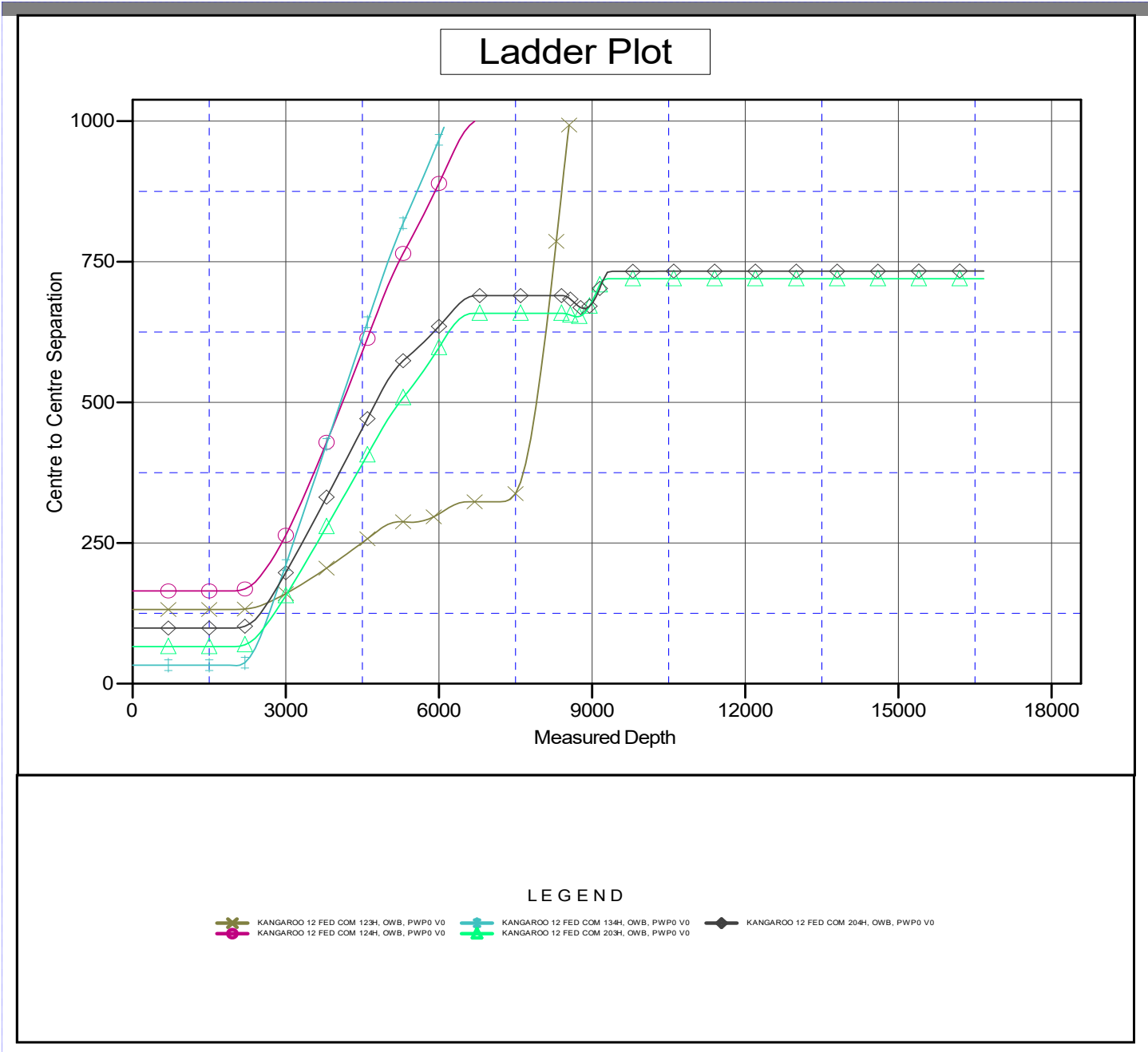

CC - Min centre to center distance or convergent point, SF - min separation factor, ES - min ellipse separation

Anticollision Report

Company:	NEW MEXICO	Local Co-ordinate Reference	Well KANGAROO 12 FED COM 133H
Project:	(SP) EDDY	TVD Reference:	KB @ 3288.6ft
Reference Site:	KANGAROO 12 FED	MD Reference:	KB @ 3288.6ft
Site Error:	0.0 ft	North Reference:	Grid
Reference Well:	KANGAROO 12 FED COM 133H	Survey Calculation Method:	Minimum Curvature
Well Error:	0.0 ft	Output errors are at	2.00 sigma
Reference Wellbore	OWB	Database:	Compass_17
Reference Design:	PWP0	Offset TVD Reference:	Offset Datum

Reference Depths are relative to KB @ 3288.6ft
 Offset Depths are relative to Offset Datum
 Central Meridian is 104° 20' 0.000 W

Coordinates are relative to: KANGAROO 12 FED COM 133H
 Coordinate System is US State Plane 1983, New Mexico Eastern Zone
 Grid Convergence at Surface is: 0.11°

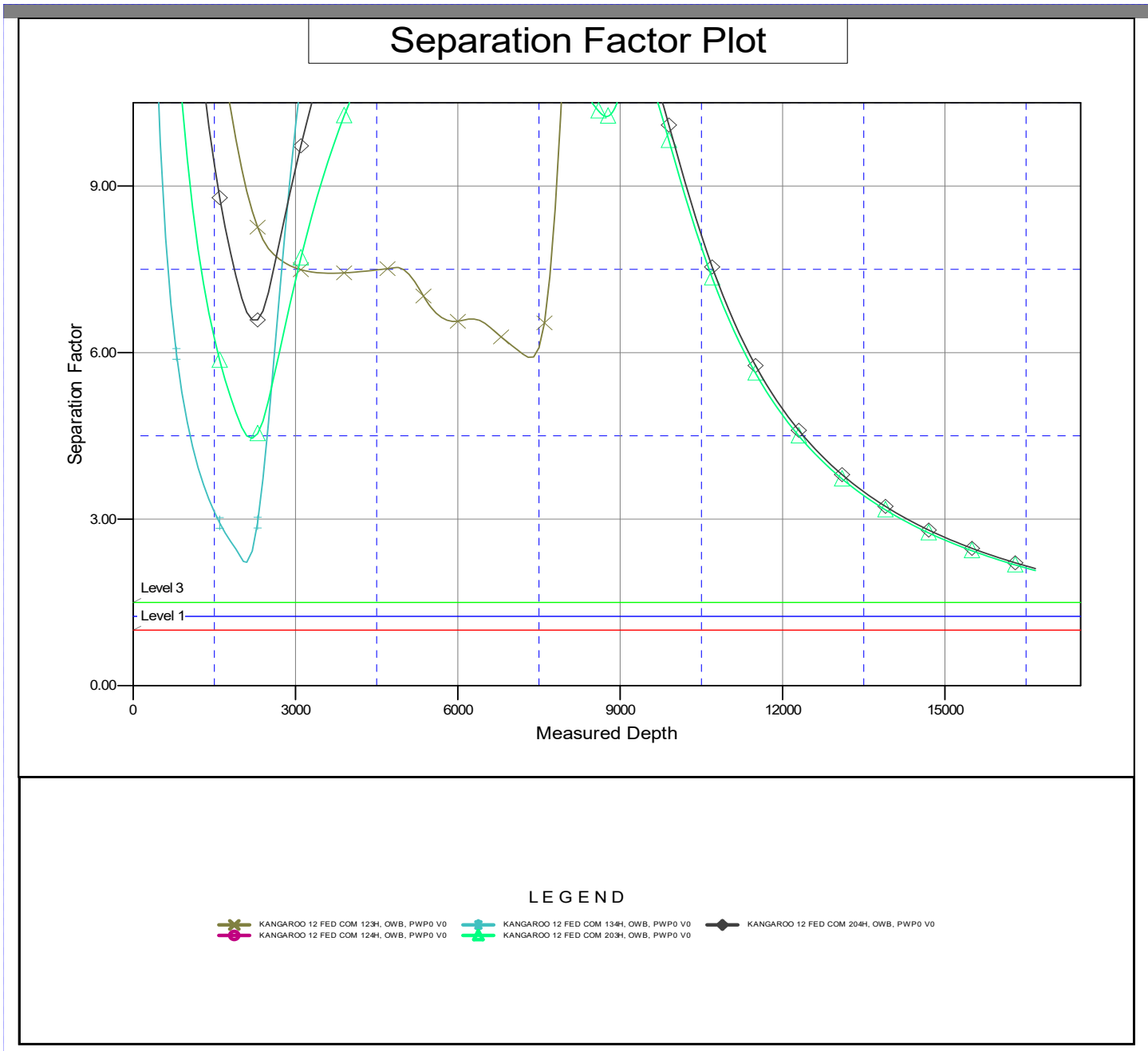

CC - Min centre to center distance or convergent point, SF - min separation factor, ES - min ellipse separation

Permian Resources

Multi-Well Pad Batch Drilling & Off Line Cement Procedure

Surface Casing - PR intends to Batch set and offline cement all surface casing to a depth approved in the APD. Surface Holes will be batch drilled by a big rig. Appropriate notifications will be made prior to spudding the well, running, and cementing casing and prior to skidding to the rig to the next well on pad.

1. Drill Surface hole to Approved Depth with Surface Preset Rig and perform wellbore cleanup cycles. Trip out and rack back drilling BHA.
2. Run casing with Cactus Multibowl system, with baseplate supported by Conductor.
3. Circulate 1.5 csg capacity.
4. Flow test – Confirm well is static.
5. Install cap flange.
6. Skid rig to next well on pad
7. Remove cap flange (confirm well is static before removal)
 - a) If well is not static use the casing outlet valves to kill well
 - b) Drillers method will be used in well control event
 - c) High pressure return line will be rigged up to lower casing valve and run to choke manifold to control annular pressure
 - d) Kill mud will be circulated once influx is circulated out of hole
 - e) Confirm well is static and remove cap flange to start offline cement operations
8. Install offline cement tool.
9. Rig up cementers.
10. Circulate bottoms up with cement truck
11. Commence planned cement job, take returns through the annulus wellhead valve
12. After plug is bumped confirm floats hold and well is static
13. Perform green cement casing test.
 - a) Test Surface casing (.22 psi/ft or 1500 psi whichever is greater) - not to exceed 70% casing burst.
14. Rig down cementers and equipment
15. Install night cap with pressure gauge to monitor.

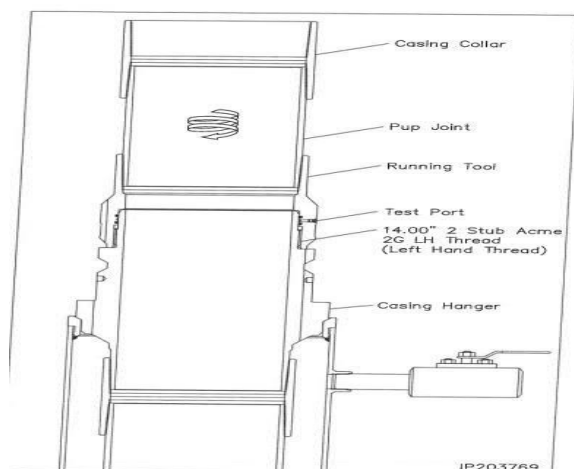

Intermediate 1 Casing – PR intends to Batch set all intermediate 1 casing strings to a depth approved in the APD, typically set into end of salts. Appropriate notifications will be made prior Testing BOPE, and prior to running/cementing all casing strings.

Rig will remove the nightcap and install and test BOPE (testing will be performed on the first Intermediate 1 as per requested break testing variance).

Install wear bushing then drill out 20" shoe-track.

1. Drill Intermediate 1 hole to approved casing point. Trip out of hole with BHA to run Casing.
2. Remove wear bushing then run and land Intermediate 1 casing with mandrel hanger in wellhead.
3. Flow test – Confirm well is static.
4. Set Annular packoff and pressure test. Test to 5k.
5. Install BPV, Nipple down BOP and install cap flange.
6. Skid rig to next well on pad
7. Remove cap flange (confirm well is static before removal)
 - a) If well is not static use the casing outlet valves to kill well
 - b) Drillers method will be used in well control event
 - c) High pressure return line will be rigged up to lower casing valve and run to choke manifold to control annular pressure
 - d) Kill mud will be circulated once influx is circulated out of hole
 - e) Confirm well is static and remove cap flange to start offline cement operations
8. Install offline cement tool.
9. Rig up cementers.
10. Circulate bottoms up with cement truck
11. Commence planned cement job, take returns through the annulus wellhead valve
12. After plug is bumped confirm floats hold and well is static
13. Perform green cement casing test.
 - a) Test casing (.22 psi/ft or 1500 psi whichever is greater) - not to exceed 70% casing burst.
14. Rig down cementers and equipment
15. Install night cap with pressure gauge to monitor.

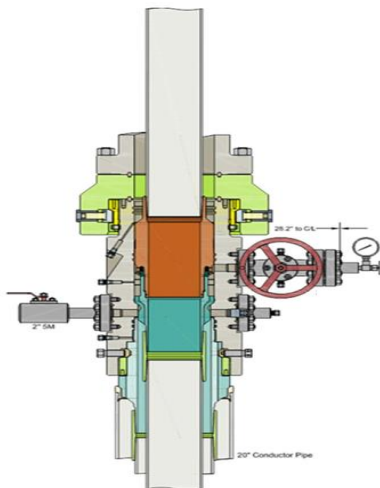

Run Intermediate Casing
Land Intermediate Casing on Mandrel Hanger
Cement Intermediate Casing
Retrieve Running Tool

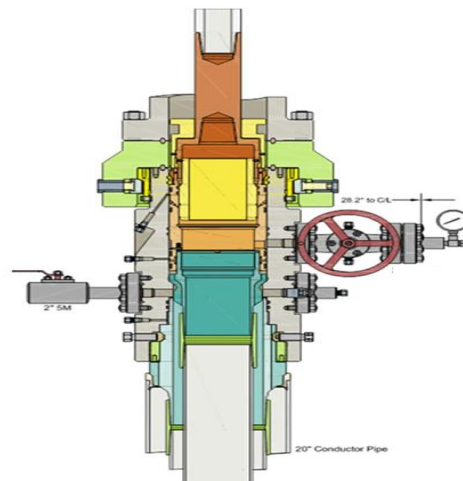

Run Packoff
Test Upper and Lower Seals
Engage Lockring
Retrieve Running Tool

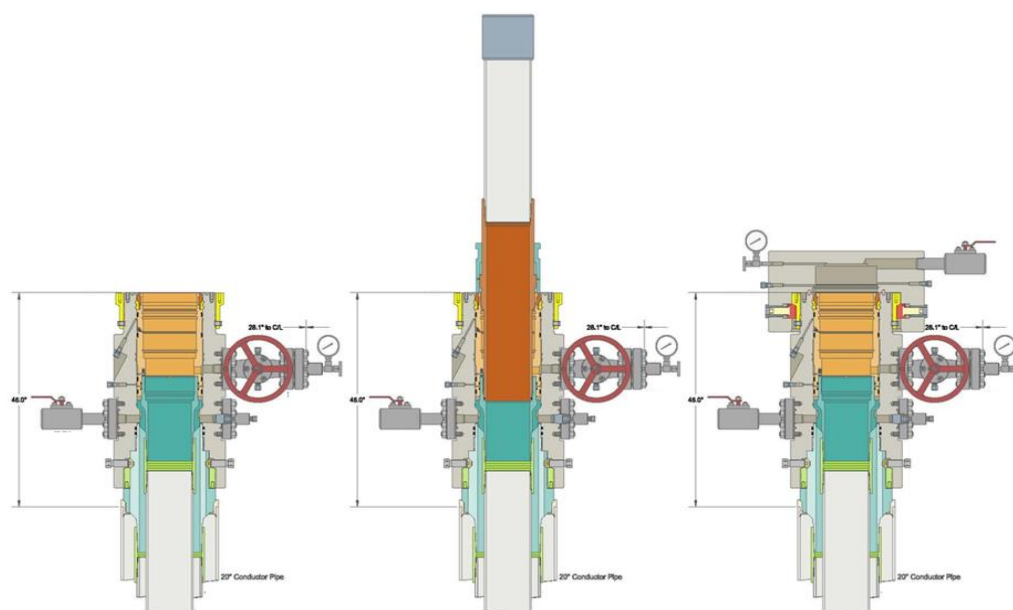

Intermediate 2 Casing – PR intends to Batch set all Intermediate 2 casing strings to a depth approved in the APD, typically set into Captain past losses. Appropriate notifications will be made prior Testing BOPE, and prior to running/cementing all casing strings.

1. Rig will remove the nightcap and install and test BOPE (testing will be performed on the first Intermediate 2 as per requested break testing variance).
2. Install wear bushing then drill out Intermediate 1 shoe-track.
3. Drill Intermediate 2 hole to approved casing point. Trip out of hole with BHA to run Casing.
4. Remove wear bushing then run and land Intermediate 2 casing with mandrel hanger in wellhead.
5. Flow test – Confirm well is static.
6. Set Annular packoff and pressure test. Test to 5k.
7. Install BPV, Nipple down BOP and install cap flange.
8. Skid rig to next well on pad
9. Remove cap flange (confirm well is static before removal)
 - a) If well is not static use the casing outlet valves to kill well
 - b) Drillers method will be used in well control event
 - c) High pressure return line will be rigged up to lower casing valve and run to choke manifold to control annular pressure
 - d) Kill mud will be circulated once influx is circulated out of hole
 - e) Confirm well is static and remove cap flange to start offline cement operations
10. Install offline cement tool.
11. Rig up cementers.
12. Circulate bottoms up with cement truck
13. Commence planned cement job, take returns through the annulus wellhead valve
14. After plug is bumped confirm floats hold and well is static
15. Perform green cement casing test.
 - a) Test casing (.22 psi/ft or 1500 psi whichever is greater) - not to exceed 70% casing burst.
16. Rig down cementers and equipment
17. Install night cap with pressure gauge to monitor.

Production Casing – PR intends to Batch set all Production casings. Appropriate notifications will be made prior Testing BOPE, and prior to running/cementing all casing strings.

1. Rig will remove the nightcap and install and test BOPE.
2. Install wear bushing then drill Intermediate shoe-track.
3. Drill Vertical hole to KOP – Trip out for Curve BHA.
4. Drill Curve, landing in production interval – Trip for Lateral BHA.
5. Drill Lateral / Production hole to Permitted BHL, perform cleanup cycles and trip out to run Production Casing.
6. Remove wear bushing then run Production casing to TD landing casing mandrel in wellhead.
7. Cement Production string to surface with floats holding.

Permian Resources BOP Break Testing Variance Procedure

Subject: Request for a Variance Allowing break Testing of the Blowout Preventer Equipment (BOPE). Permian Resources requests a variance to ONLY test broken pressure seals on the BOPE and function test BOP when skidding a drilling rig between multiple wells on a pad.

Background

Title 43 CFR 3172, Drilling Operations, Sections 6.b.9.iv states that the BOP test must be performed whenever any seal subject to test pressure is broken. The current interpretation of the Bureau of Land Management (BLM) requires a complete BOP test and not just a test of the affected component. 43 CFR 3172.13, Variances from minimum standards states, "An operator may request the authorized officer to approve a variance from any of the minimum standards prescribed in [§§ 3172.6](#) through [3172.12](#). All such requests shall be submitted in writing to the appropriate authorized officer and provide information as to the circumstances which warrant approval of the variance(s) requested and the proposed alternative methods by which the related minimum standard(s) are to be satisfied. The authorized officer, after considering all relevant factors, if appropriate, may approve the requested variance(s) if it is determined that the proposed alternative(s) meet or exceed the objectives of the applicable minimum standard(s)". Permian Resources feels the break testing the BOPE is such a situation. Therefore, as per 43 CFR 3172.13, Permian Resources submits this request for the variance.

Supporting Documentation

The language used in 43 CFR 3172 became effective on December 19, 1988 and has remained the standard for regulating BLM onshore drilling operations for over 30 years. During this time, there have been significant changes in drilling technology. The BLM continues to use the variance request process to allow for the use of modern technology and acceptable engineering practices that have arisen since 43 CFR 3172 was originally released. The Permian Resources drilling rig fleet has many modern upgrades that allow the intact BOP stack to be moved between well slots on a multi-well pad, as well as, wellhead designs that incorporate quick connects facilitating release of the BOP from the wellhead without breaking any BOP stack components apart. These technologies have been used extensively offshore, and other regulators, API, and many operators around the world have endorsed break testing as safe and reliable.

Figure 1: Winch System attached to BOP Stack



Figure 2: BOP Winch System



American Petroleum Institute (API) standards, specification and recommended practices are considered the industry standard and are consistently utilized and referenced by the industry. 43 CFR 3172 recognizes API recommended Practices (RP) 53 in its original development. API Standard 53, Well Control Equipment Systems for Drilling Wells (Fifth Edition, December 2018, Annex C, Table C.4) recognizes break testing as an acceptable practice. Specifically, API Standard 53, Section 5.3.7.1 states "A pressure test of the pressure containing component shall be performed following the disconnection or repair, limited to the affected component." See Table C.4 below for reference.

62		API STANDARD 53	
Table C.4—Initial Pressure Testing, Surface BOP Stacks			
Component to be Pressure Tested	Pressure Test—Low Pressure ¹ psig (MPa)	Pressure Test—High Pressure ²	
		Change Out of Component, Elastomer, or Ring Gasket	No Change Out of Component, Elastomer, or Ring Gasket
Annular preventer ³	250 to 350 (1.72 to 2.41)	RWP of annular preventer	MASP or 70% annular RWP, whichever is lower.
Fixed pipe, variable bore, blind, and BSR preventers ³	250 to 350 (1.72 to 2.41)	RWP of ram preventer or wellhead system, whichever is lower	ITP
Choke and kill line and BOP side outlet valves below ram preventers (both sides)	250 to 350 (1.72 to 2.41)	RWP of side outlet valve or wellhead system, whichever is lower	ITP
Choke manifold—upstream of chokes ⁴	250 to 350 (1.72 to 2.41)	RWP of ram preventers or wellhead system, whichever is lower	ITP
Choke manifold—downstream of chokes ⁴	250 to 350 (1.72 to 2.41)	RWP of valve(s), line(s), or MASP for the well program, whichever is lower	
Kelly, kelly valves, drill pipe safety valves, IBOPs	250 to 350 (1.72 to 2.41)	MASP for the well program	

¹ Pressure test evaluation periods shall be a minimum of five minutes. No visible leaks. The pressure shall remain stable during the evaluation period. The pressure shall not decrease below the intended test pressure.

² Annular(s) and VBR(s) shall be pressure tested on the largest and smallest OD drill pipe to be used in well program.

³ For pad drilling operations, moving from one wellhead to another within the 21 days, pressure testing is required for pressure-containing and pressure-controlling connections when the integrity of a pressure seal is broken.

⁴ For surface offshore operations, the ram BOPs shall be pressure tested with the ram locks engaged and the closing and locking pressure vented during the initial test. For land operations, the ram BOPs shall be pressure tested with the ram locks engaged and the closing and locking pressure vented at commissioning and annually.

* Adjustable chokes are not required to be full sealing devices. Pressure testing against a closed choke is not required.

The Bureau of Safety and Environmental Enforcement (BSEE), Department of Interior, has also utilized the API standards, specification and best practices in the development of its offshore oil and gas regulations and incorporates them by reference within its regulations.

Break testing has been approved by the BLM in the past with other operators based on the detailed information provided in this document.

Permian Resources feels break testing and our current procedures meet the intent of 43 CFR 3172 and often exceed it. There has been no evidence that break testing results in more components failing than seen on full BOP tests. Permian Resources internal standards require complete BOPE tests more often than that of 43 CFR 3172 (every 21 days). In addition to function testing the annular, pipe rams and blind rams after each BOP nipple up, Permian Resources performs a choke drill with the rig crew prior to drilling out every casing shoe. This is additional training for the rig crew that exceeds the requirements of 43 CFR 3172.

Procedures

- 1) Permian Resources will use this document for our break testing plan for New Mexico Delaware Basin. The summary below will be referenced in the APD or Sundry Notice and receive approval prior to implementing this variance.
- 2) Permian Resources will perform BOP break testing on multi-wells pads where multiple intermediate sections can be drilled and cased within the 21-day BOP test window.
 - a) A full BOP test will be conducted on the first well on the pad.
 - b) The first intermediate hole section drilled on the pad will be the deepest. All the remaining hole sections will be the same formation depth or shallower.
 - c) A full BOP test will be required if the intermediate hole section being drilled has a MASP over 5M.
 - d) A full BOP test will be required prior to drilling any production hole.
- 3) After performing a complete BOP test on the first well, the intermediate hole section will be drilled and cased, two breaks would be made on the BOP equipment.
 - a) Between the HCV valve and choke line connection
 - b) Between the BOP quick connect and the wellhead
- 4) The BOP is then lifted and removed from the wellhead by a hydraulic system.
- 5) After skidding to the next well, the BOP is moved to the wellhead by the same hydraulic system and installed.
- 6) The connections mentioned in 3a and 3b will then be reconnected.
- 7) Install test plug into the wellhead using test joint or drill pipe.
- 8) A shell test is performed against the upper pipe rams testing the two breaks.
- 9) The shell test will consist of a 250 psi low test and a high test to the value submitted in the APD or Sundry (e.g. 5,000 psi or 10,000psi).
- 10) Function tests will be performed on the following components: lower pipe rams, blind rams, and annular.
- 11) For a multi-well pad the same two breaks on the BOP would be made and on the next wells and steps 4 through 10 would be repeated.
- 12) A second break test would only be done if the intermediate hole section being drilled could not be completed within the 21 day BOP test window.

Note: Picture below highlights BOP components that will be tested during batch operations

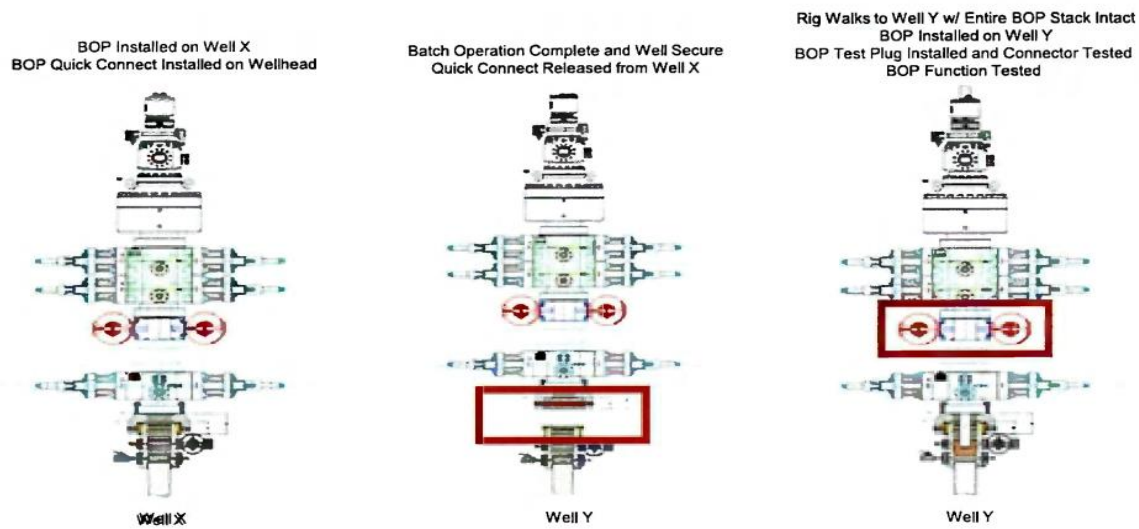

Summary

A variance is requested to ONLY test broken pressure seals on the BOP equipment when moving from wellhead to wellhead which is in compliance with API Standard 53. API Standard 53 states, that for pad drilling operations, moving from one wellhead to another within 21 days, pressure testing is required for pressure-containing and pressure-controlling connections when the integrity of a pressure seal is broken.

The BOP will be secured by a hydraulic carrier or cradle. The BLM will be contacted if a Well Control event occurs prior to the commencement of a BOPE Break Testing operation.

Based on public data and the supporting documentation submitted herein to the BLM, we will request permission to ONLY retest broken pressure seals if the following conditions are met:

- 1) After a full BOP test is conducted on the first well on the pad.
- 2) The first intermediate hole section drilled on the pad will be the deepest. All the remaining hole sections will be the same depth or shallower.
- 3) A full BOP test will be required if the intermediate hole section being drilled has a MASP over 5M.
- 4) A full BOP test will be required prior to drilling the production hole.

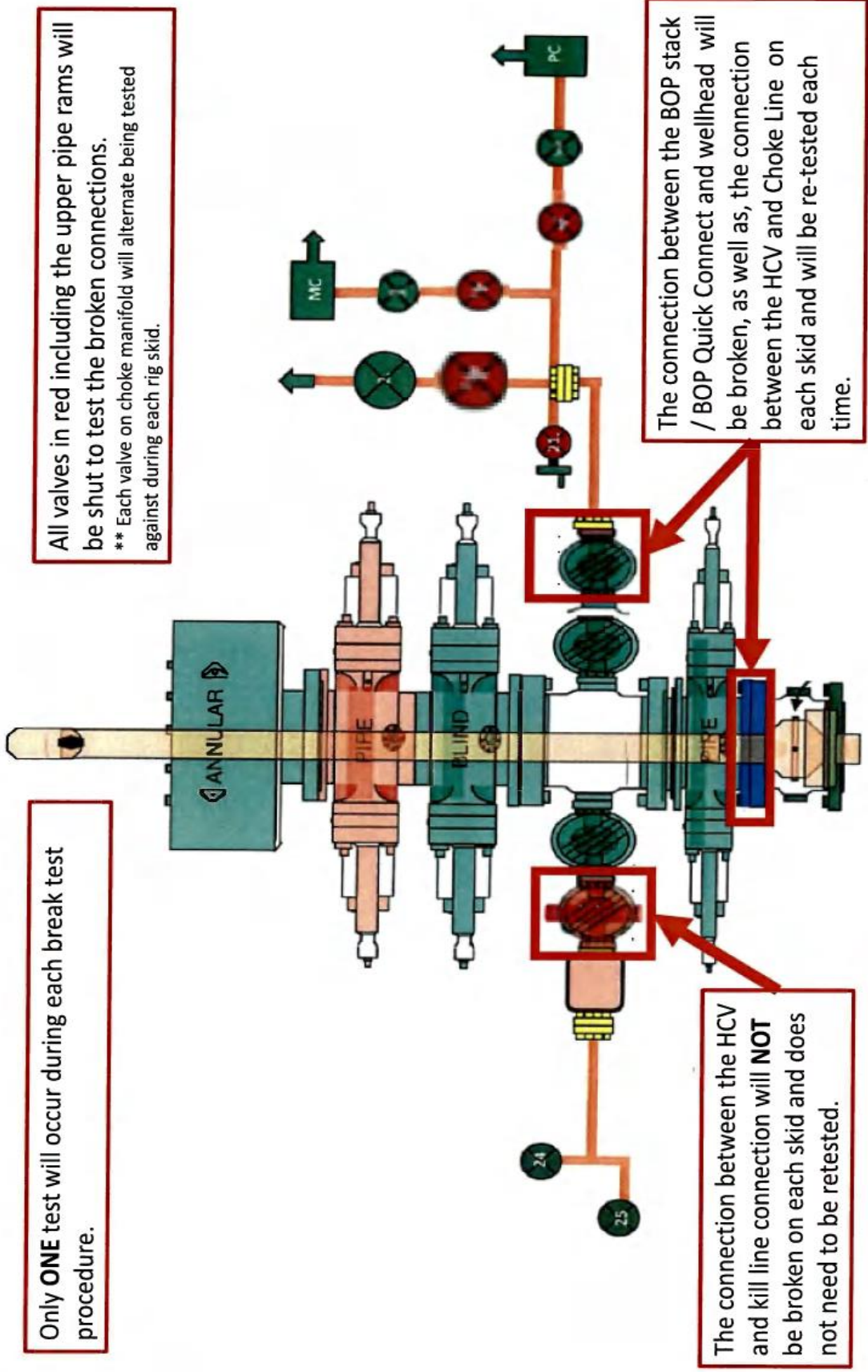

Only **ONE** test will occur during each break test procedure.

All valves in red including the upper pipe rams will be shut to test the broken connections.
** Each valve on choke manifold will alternate being tested against during each rig skid.

The connection between the HCV and kill line connection will **NOT** be broken on each skid and does not need to be retested.

The connection between the BOP stack / BOP Quick Connect and wellhead will be broken, as well as, the connection between the HCV and Choke Line on each skid and will be re-tested each time.



CONTITECH RUBBER Industrial Kft.	No:QC-DB- 210/ 2014
	Page: 9 / 113

QUALITY CONTROL INSPECTION AND TEST CERTIFICATE		CERT. N°: 504	
PURCHASER: ContiTech Oil & Marine Corp.		P.O. N°: 4500409659	
CONTITECH RUBBER order N°: 538236	HOSE TYPE: 3" ID	Choke and Kill Hose	
HOSE SERIAL N°: 67255	NOMINAL / ACTUAL LENGTH: 10,67 m / 10,77 m		
W.P. 68,9 MPa 10000 psi	T.P. 103,4 MPa 15000 psi	Duration: 60 min.	
Pressure test with water at ambient temperature			
See attachment. (1 page)			
↑ 10 mm = 10 Min. → 10 mm = 20 MPa			
COUPLINGS Type	Serial N°	Quality	Heat N°
3" coupling with 4 1/16" 10K API b.w. Flange end	9251 9254	AISI 4130	A0579N
		AISI 4130	035608
Not Designed For Well Testing		API Spec 16 C	
		Temperature rate:"B"	
All metal parts are flawless			
WE CERTIFY THAT THE ABOVE HOSE HAS BEEN MANUFACTURED IN ACCORDANCE WITH THE TERMS OF THE ORDER INSPECTED AND PRESSURE TESTED AS ABOVE WITH SATISFACTORY RESULT.			
STATEMENT OF CONFORMITY: We hereby certify that the above items/equipment supplied by us are in conformity with the terms, conditions and specifications of the above Purchaser Order and that these items/equipment were fabricated inspected and tested in accordance with the referenced standards, codes and specifications and meet the relevant acceptance criteria and design requirements.			
COUNTRY OF ORIGIN HUNGARY/EU			
Date:	Inspector	Quality Control	
20. March 2014.		ContiTech Rubber Industrial Kft. Quality Control Dept. 	

ContiTech Rubber Industrial Kft. | Budapest (at 76. H-6728 Szeged) | H-6701 P.O.Box 152 Szeged, Hungary
 Phone: +36 62 568 727 | Fax: +36 62 568 728 | e-mail: info@rubr.contitech.hu | Internet: www.contitech.hu
 The Court of Company Registration | Registry Court No: Cg-95-08-202503 | EU VAT No: HU1837209
 Bank data: Commerzbank Zrt., Budapest | 14220158-20629003

ATTACHMENT OF QUALITY CONTROL INSPECTION AND TEST CERTIFICATE No: 501, 504, 505

Page: 1 / 1

John J. ...
Control Dept.

GN	+21.22	OC	01:23	
RD	+21.22	OC	01:23	
BL	+1853.	bor	01:20	
GN	+21.15	OC	01:18	
RD	+21.01	OC	01:18	
BL	+1855.	bor	01:18	
GN	+21.18	OC	01:08	
RD	+21.38	OC	01:08	
BL	+1856.	bor	01:00	
GN	+21.28	OC	00:58	10-in-10.5 inch
RD	+21.30	OC	00:58	
BL	+1857.	bor	00:58	
GN	+21.28	OC	00:48	
RD	+21.34	OC	00:48	
BL	+1858.	bor	00:48	
GN	+21.38	OC	00:38	
RD	+21.48	OC	00:38	
BL	+1861.	bor	00:38	
GN	+21.38	OC	00:28	
RD	+21.38	OC	00:28	
BL	+1864.	bor	00:28	

0 10 20 30 40 50 60 70 80 90 100

19-05-2014-23-58
67252, 67253, 67254, 234 53



CONTITECH RUBBER Industrial Kft.	No:QC-DB- 210/ 2014
	Page: 15 / 113
ContiTech	

Hose Data Sheet

CRI Order No.	538236
Customer	ContiTech Oil & Marine Corp.
Customer Order No	4500409659
Item No.	1
Hose Type	Flexible Hose
Standard	API SPEC 16 C
Inside dia in inches	3
Length	35 ft
Type of coupling one end	FLANGE 4. 1/16" 10K API SPEC 6A TYPE 6BX FLANGE C/W BX155 R.GR.SOUR
Type of coupling other end	FLANGE 4. 1/16" 10K API SPEC 6A TYPE 6BX FLANGE C/W BX155 R.GR.SOUR
H2S service NACE MR0175	Yes
Working Pressure	10 000 psi
Design Pressure	10 000 psi
Test Pressure	15 000 psi
Safety Factor	2,25
Marking	USUAL PHOENIX
Cover	NOT FIRE RESISTANT
Outside protection	St. steel outer wrap
Internal stripwound tube	No
Lining	OIL + GAS RESISTANT SOUR
Safety clamp	No
Lifting collar	No
Element C	No
Safety chain	No
Safety wire rope	No
Max. design temperature [°C]	100
Min. design temperature [°C]	-20
Min. Bend Radius operating [m]	0,90
Min. Bend Radius storage [m]	0,90
Electrical continuity	The Hose is electrically continuous
Type of packing	WOODEN CRATE ISPM-15

Printed: TIRETECH2\CsontosG - 2014.03.10 15:22:17

Sante Fe Main Office
Phone: (505) 476-3441

General Information
Phone: (505) 629-6116

Online Phone Directory
<https://www.emnrd.nm.gov/oecd/contact-us>

State of New Mexico
Energy, Minerals and Natural Resources
Oil Conservation Division
1220 S. St Francis Dr.
Santa Fe, NM 87505

CONDITIONS

Action 468801

CONDITIONS

Operator: Permian Resources Operating, LLC 300 N. Marienfeld St Ste 1000 Midland, TX 79701	OGRID: 372165
	Action Number: 468801
	Action Type: [C-103A] NOI Change of Plans (C-103A)

CONDITIONS

Created By	Condition	Condition Date
ward.rikala	Operator performed work without OCD approval.	4/23/2026