

U.S. Department of the Interior
BUREAU OF LAND MANAGEMENT

Well Name: SILVER BAR 35 FED STATE COM	Well Location: T19S / R29E / SEC 35 / SWSW / 32.6126937 / -104.0539449	County or Parish/State: EDDY / NM
Well Number: 133H	Type of Well: OIL WELL	Allottee or Tribe Name:
Lease Number: NMNM24160	Unit or CA Name:	Unit or CA Number:
US Well Number: 3001547971	Operator: PERMIAN RESOURCES OPERATING LLC	

Notice of Intent

Sundry ID: 2819949

Type of Submission: Notice of Intent

Type of Action: APD Change

Date Sundry Submitted: 10/30/2024

Time Sundry Submitted: 12:39

Date proposed operation will begin: 11/26/2024

Procedure Description: Permian Resources Operating, LLC requests permission to make the following changes to the original APD: SHL/TP/BHL Changes, Total Depth (TVD/MD), Include Drilling Variances (List Below). Original APD ID: 10400054930 Well Name/Number Change: From: Silver Bar 35 Fed State Com 133H TO: Silver Bar 35-36 Fed State Com 133H Pool: Revised Change From: (49637) Parkway; Wolfcamp Change To: (49622) Parkway; Bone Springs Surface Location: Revised Change From: 1015' FSL & 65' FWL, SWSW-Sec 35-19S-29E Change To: 1054' FSL & 359' FEL, SESE-Sec 34-19S-29E Lease Number: No Change FTP: Revised Change From: 1730' FSL & 100'FWL, NWSW-Sec 35-19S-29E Change To: 2310' FSL & 100' FWL, NWSW -Sec 35-19S-29E Lease Number: No Change LTP: Revised Change From: 1730' FSL & 100'FEL, NESE-Sec 36-19S-29E Change To: 2310' FSL & 100' FEL, NESE - Sec 36-19S-29E Lease Number: No Change BHL: Revised Change From: 1730' FSL & 10' FEL, NESE-Sec 36-19S-29E Change To: 2310' FSL & 100' FEL, NESE -Sec 36-19S-29E Lease Number: No Change New Total Depth (TVD/MD): 9228' TVD/19,948'MD Updated Drilling Program Attached Reflecting TVD/MD Changes Drilling Variance Requested: Bradenhead Squeeze (2nd Intermediate) Batch BOP Break OCV Flex Hose Attachments: 1. Updated C102 2. Drilling Program (4-String Capitan Reef Design. R-111-Q Not Required) 3. Directional Plan & Anticollision Report 4. Variances

NOI Attachments

Procedure Description

Silver_Bar_35_36_Fed_State_133H_Sundry_Attachments_20241030123901.pdf

Well Name: SILVER BAR 35 FED STATE COM

Well Location: T19S / R29E / SEC 35 / SWSW / 32.6126937 / -104.0539449

County or Parish/State: EDDY / NM

Well Number: 133H

Type of Well: OIL WELL

Allottee or Tribe Name:

Lease Number: NMNM24160

Unit or CA Name:

Unit or CA Number:

US Well Number: 3001547971

Operator: PERMIAN RESOURCES OPERATING LLC

Conditions of Approval

Additional

Sec_34_19S_29E_NMP_Sundry_2819949_Silver_Bar_35_36_Fed_State_Com_133H_COAs_20241217100551.pdf

Operator

I certify that the foregoing is true and correct. Title 18 U.S.C. Section 1001 and Title 43 U.S.C. Section 1212, make it a crime for any person knowingly and willfully to make to any department or agency of the United States any false, fictitious or fraudulent statements or representations as to any matter within its jurisdiction. Electronic submission of Sundry Notices through this system satisfies regulations requiring a

Operator Electronic Signature: CASSIE EVANS

Signed on: DEC 16, 2024 06:14 PM

Name: PERMIAN RESOURCES OPERATING LLC

Title: Regulatory Specialist

Street Address: 300 N MARIENFELD ST STE 1000

City: MIDLAND

State: TX

Phone: (432) 260-4388

Email address: CASSIE.EVANS@PERMIANRES.COM

Field

Representative Name:

Street Address:

City:

State:

Zip:

Phone:

Email address:

BLM Point of Contact

BLM POC Name: CHRISTOPHER WALLS

BLM POC Title: Petroleum Engineer

BLM POC Phone: 5752342234

BLM POC Email Address: cwalls@blm.gov

Disposition: Approved

Disposition Date: 12/17/2024

Signature: Chris Walls

Form 3160-5
(June 2019)

UNITED STATES
DEPARTMENT OF THE INTERIOR
BUREAU OF LAND MANAGEMENT

FORM APPROVED
OMB No. 1004-0137
Expires: October 31, 2021

SUNDRY NOTICES AND REPORTS ON WELLS
Do not use this form for proposals to drill or to re-enter an abandoned well. Use Form 3160-3 (APD) for such proposals.

5. Lease Serial No.	NMNM24160
6. If Indian, Allottee or Tribe Name	

SUBMIT IN TRIPLICATE - Other instructions on page 2		7. If Unit of CA/Agreement, Name and/or No.
1. Type of Well <input checked="" type="checkbox"/> Oil Well <input type="checkbox"/> Gas Well <input type="checkbox"/> Other		8. Well Name and No. SILVER BAR 35 FED STATE COM/133H
2. Name of Operator PERMIAN RESOURCES OPERATING LLC		9. API Well No. 3001547971
3a. Address 300 N MARIENFELD ST SUITE 1000, MIDLAND	3b. Phone No. (include area code) (432) 695-4222	10. Field and Pool or Exploratory Area Parkway/BONE SPRING
4. Location of Well (Footage, Sec., T.,R.,M., or Survey Description) SEC 35/T19S/R29E/NMP		11. Country or Parish, State EDDY/NM

12. CHECK THE APPROPRIATE BOX(ES) TO INDICATE NATURE OF NOTICE, REPORT OR OTHER DATA

TYPE OF SUBMISSION	TYPE OF ACTION			
<input checked="" type="checkbox"/> Notice of Intent	<input type="checkbox"/> Acidize	<input type="checkbox"/> Deepen	<input type="checkbox"/> Production (Start/Resume)	<input type="checkbox"/> Water Shut-Off
<input type="checkbox"/> Subsequent Report	<input type="checkbox"/> Alter Casing	<input type="checkbox"/> Hydraulic Fracturing	<input type="checkbox"/> Reclamation	<input type="checkbox"/> Well Integrity
<input type="checkbox"/> Final Abandonment Notice	<input type="checkbox"/> Casing Repair	<input type="checkbox"/> New Construction	<input type="checkbox"/> Recomplete	<input type="checkbox"/> Other
	<input checked="" type="checkbox"/> Change Plans	<input type="checkbox"/> Plug and Abandon	<input type="checkbox"/> Temporarily Abandon	
	<input type="checkbox"/> Convert to Injection	<input type="checkbox"/> Plug Back	<input type="checkbox"/> Water Disposal	

13. Describe Proposed or Completed Operation: Clearly state all pertinent details, including estimated starting date of any proposed work and approximate duration thereof. If the proposal is to deepen directionally or recomplete horizontally, give subsurface locations and measured and true vertical depths of all pertinent markers and zones. Attach the Bond under which the work will be performed or provide the Bond No. on file with BLM/BIA. Required subsequent reports must be filed within 30 days following completion of the involved operations. If the operation results in a multiple completion or recompletion in a new interval, a Form 3160-4 must be filed once testing has been completed. Final Abandonment Notices must be filed only after all requirements, including reclamation, have been completed and the operator has determined that the site is ready for final inspection.)

Permian Resources Operating, LLC requests permission to make the following changes to the original APD: SHL/TP/BHL Changes, Total Depth (TVD/MD), Include Drilling Variances (List Below).

Original APD ID: 10400054930

Well Name/Number Change:

From: Silver Bar 35 Fed State Com 133H

TO: Silver Bar 35-36 Fed State Com 133H

Pool: Revised

Change From: (49637) Parkway; Wolfcamp

Change To: (49622) Parkway; Bone Springs

Continued on page 3 additional information

14. I hereby certify that the foregoing is true and correct. Name (Printed/Typed) CASSIE EVANS / Ph: (432) 260-4388	Title Regulatory Specialist
Signature (Electronic Submission)	Date 12/16/2024

THE SPACE FOR FEDERAL OR STATE OFFICE USE

Approved by CHRISTOPHER WALLS / Ph: (575) 234-2234 / Approved	Title Petroleum Engineer	Date 12/17/2024
Conditions of approval, if any, are attached. Approval of this notice does not warrant or certify that the applicant holds legal or equitable title to those rights in the subject lease which would entitle the applicant to conduct operations thereon.	Office CARLSBAD	

Title 18 U.S.C Section 1001 and Title 43 U.S.C Section 1212, make it a crime for any person knowingly and willfully to make to any department or agency of the United States any false, fictitious or fraudulent statements or representations as to any matter within its jurisdiction.

(Instructions on page 2)

GENERAL INSTRUCTIONS

This form is designed for submitting proposals to perform certain well operations and reports of such operations when completed as indicated on Federal and Indian lands pursuant to applicable Federal law and regulations. Any necessary special instructions concerning the use of this form and the number of copies to be submitted, particularly with regard to local area or regional procedures and practices, are either shown below, will be issued by or may be obtained from the local Federal office.

SPECIFIC INSTRUCTIONS

Item 4 - Locations on Federal or Indian land should be described in accordance with Federal requirements. Consult the local Federal office for specific instructions.

Item 13: Proposals to abandon a well and subsequent reports of abandonment should include such special information as is required by the local Federal office. In addition, such proposals and reports should include reasons for the abandonment; data on any former or present productive zones or other zones with present significant fluid contents not sealed off by cement or otherwise; depths (top and bottom) and method of placement of cement plugs; mud or other material placed below, between and above plugs; amount, size, method of parting of any casing, liner or tubing pulled and the depth to the top of any tubing left in the hole; method of closing top of well and date well site conditioned for final inspection looking for approval of the abandonment. If the proposal will involve **hydraulic fracturing operations**, you must comply with 43 CFR 3162.3-3, including providing information about the protection of usable water. Operators should provide the best available information about all formations containing water and their depths. This information could include data and interpretation of resistivity logs run on nearby wells. Information may also be obtained from state or tribal regulatory agencies and from local BLM offices.

NOTICES

The privacy Act of 1974 and the regulation in 43 CFR 2.48(d) provide that you be furnished the following information in connection with information required by this application.

AUTHORITY: 30 U.S.C. 181 et seq., 351 et seq., 25 U.S.C. 396; 43 CFR 3160.

PRINCIPAL PURPOSE: The information is used to: (1) Evaluate, when appropriate, approve applications, and report completion of subsequent well operations, on a Federal or Indian lease; and (2) document for administrative use, information for the management, disposal and use of National Resource lands and resources, such as: (a) evaluating the equipment and procedures to be used during a proposed subsequent well operation and reviewing the completed well operations for compliance with the approved plan; (b) requesting and granting approval to perform those actions covered by 43 CFR 3162.3-2, 3162.3-3, and 3162.3-4; (c) reporting the beginning or resumption of production, as required by 43 CFR 3162.4-1(c) and (d) analyzing future applications to drill or modify operations in light of data obtained and methods used.

ROUTINE USES: Information from the record and/or the record will be transferred to appropriate Federal, State, local or foreign agencies, when relevant to civil, criminal or regulatory investigations or prosecutions in connection with congressional inquiries or to consumer reporting agencies to facilitate collection of debts owed the Government.

EFFECT OF NOT PROVIDING THE INFORMATION: Filing of this notice and report and disclosure of the information is mandatory for those subsequent well operations specified in 43 CFR 3162.3-2, 3162.3-3, 3162.3-4.

The Paperwork Reduction Act of 1995 requires us to inform you that:

The BLM collects this information to evaluate proposed and/or completed subsequent well operations on Federal or Indian oil and gas leases.

Response to this request is mandatory.

The BLM would like you to know that you do not have to respond to this or any other Federal agency-sponsored information collection unless it displays a currently valid OMB control number.

BURDEN HOURS STATEMENT: Public reporting burden for this form is estimated to average 8 hours per response, including the time for reviewing instructions, gathering and maintaining data, and completing and reviewing the form. Direct comments regarding the burden estimate or any other aspect of this form to U.S. Department of the Interior, Bureau of Land Management (1004-0137), Bureau Information Collection Clearance Officer (WO-630), 1849 C St., N.W., Mail Stop 401 LS, Washington, D.C. 20240

Additional Information

Additional Remarks

Surface Location: Revised

Change From: 1015 FSL & 65 FWL, SWSW-Sec 35-19S-29E

Change To: 1054 FSL & 359 FEL, SESE-Sec 34-19S-29E

Lease Number: No Change

FTP: Revised

Change From: 1730 FSL & 100FWL, NWSW-Sec 35-19S-29E

Change To: 2310 FSL & 100 FWL, NWSW -Sec 35-19S-29E

Lease Number: No Change

LTP: Revised

Change From: 1730 FSL & 100FEL, NESE-Sec 36-19S-29E

Change To: 2310 FSL & 100 FEL, NESE -Sec 36-19S-29E

Lease Number: No Change

BHL: Revised

Change From: 1730 FSL & 10 FEL, NESE-Sec 36-19S-29E

Change To: 2310 FSL & 100 FEL, NESE -Sec 36-19S-29E

Lease Number: No Change

New Total Depth (TVD/MD): 9228 TVD/19,948MD

Updated Drilling Program Attached Reflecting TVD/MD Changes

Drilling Variance Requested:

Bradenhead Squeeze (2nd Intermediate)

Batch

BOP Break

OCV

Flex Hose

Attachments:

1. Updated C102
2. Drilling Program (4-String Capitan Reef Design. R-111-Q Not Required)
3. Directional Plan & Anticollision Report
4. Variances

Location of Well

0. SHL: SWSW / 1015 FSL / 65 FWL / TWSP: 19S / RANGE: 29E / SECTION: 35 / LAT: 32.6126937 / LONG: -104.0539449 (TVD: 0 feet, MD: 0 feet)

PPP: NWSW / 1665 FSL / 79 FWL / TWSP: 19S / RANGE: 29E / SECTION: 35 / LAT: 32.6144734 / LONG: -104.0538996 (TVD: 8867 feet, MD: 8906 feet)

PPP: NESE / 1730 FSL / 1320 FEL / TWSP: 19S / RANGE: 29E / SECTION: 35 / LAT: 32.614571 / LONG: -104.041344 (TVD: 9283 feet, MD: 12898 feet)

BHL: NESE / 1730 FSL / 10 FEL / TWSP: 19S / RANGE: 29E / SECTION: 36 / LAT: 32.6144414 / LONG: -104.0198632 (TVD: 9417 feet, MD: 19528 feet)

PECOS DISTRICT DRILLING CONDITIONS OF APPROVAL

OPERATOR'S NAME: Permian Resources Operating LLC
WELL NAME & NO.: Silver Bar 35-36 Fed State Com 133H
LOCATION: Sec 34-19S-29E-NMP
COUNTY: Eddy County, New Mexico

*Changes approved through engineering via **Sundry 2819949** on 12/16/2024. Any previous COAs not addressed within the updated COAs still apply.*

COA

H ₂ S	<input type="radio"/> No		<input checked="" type="radio"/> Yes	
Potash / WIPP	<input checked="" type="radio"/> None	<input type="radio"/> Secretary	<input type="radio"/> R-111-Q	<input type="checkbox"/> Open Annulus <input type="checkbox"/> WIPP
Cave / Karst	<input type="radio"/> Low	<input type="radio"/> Medium	<input checked="" type="radio"/> High	<input type="radio"/> Critical
Wellhead	<input type="radio"/> Conventional	<input checked="" type="radio"/> Multibowl	<input type="radio"/> Both	<input type="radio"/> Diverter
Cementing	<input type="checkbox"/> Primary Squeeze	<input checked="" type="checkbox"/> Cont. Squeeze	<input checked="" type="checkbox"/> EchoMeter	<input type="checkbox"/> DV Tool
Special Req	<input checked="" type="checkbox"/> Capitan Reef	<input type="checkbox"/> Water Disposal	<input checked="" type="checkbox"/> COM	<input type="checkbox"/> Unit
Waste Prev.	<input type="radio"/> Self-Certification	<input type="radio"/> Waste Min. Plan	<input checked="" type="radio"/> APD Submitted prior to 06/10/2024	
Additional Language	<input checked="" type="checkbox"/> Flex Hose	<input type="checkbox"/> Casing Clearance	<input type="checkbox"/> Pilot Hole	<input checked="" type="checkbox"/> Break Testing
	<input checked="" type="checkbox"/> Four-String	<input checked="" type="checkbox"/> Offline Cementing	<input type="checkbox"/> Fluid-Filled	

A. HYDROGEN SULFIDE

A Hydrogen Sulfide (H₂S) Drilling Plan shall be activated 500 feet prior to drilling into the **Parkway** formation. As a result, the Hydrogen Sulfide area must meet all requirements from 43 CFR 3176, which includes equipment and personnel/public protection items. If Hydrogen Sulfide is encountered, please provide measured values and formations to the BLM.

B. CASING

1. The **13-3/8** inch surface casing shall be set at approximately **45** feet (a minimum of **25 feet** into the Rustler Anhydrite, above the salt, and below usable fresh water) and cemented to the surface. *Set depth adjusted per BLM geologist.*
 - a. If cement does not circulate to the surface, the appropriate BLM office shall be notified and a temperature survey utilizing an electronic type temperature survey with surface log readout will be used or a cement bond log shall be run to verify the top of the cement. Temperature survey will be run a minimum of six hours after pumping cement and ideally between 8-10 hours after completing the cement job.

- b. Wait on cement (WOC) time for a primary cement job will be a minimum of **8 hours** or **500 pounds compressive strength**, whichever is greater. (This is to include the lead cement)
 - c. Wait on cement (WOC) time for a remedial job will be a minimum of 4 hours after bringing cement to surface or 500 pounds compressive strength, whichever is greater.
 - d. If cement falls back, remedial cementing will be done prior to drilling out that string.
2. The minimum required fill of cement behind the **10-3/4** inch intermediate casing is:
- Cement to surface. If cement does not circulate see B.1.a, c-d above. **Wait on cement (WOC) time for a primary cement job is to include the lead cement slurry due to cave/karst, Capitan Reef, or potash.**
 - ❖ In Capitan Reef Areas if cement does not circulate to surface on the first two casing strings, the cement on the 3rd casing string must come to surface.
 - ❖ In High Cave / Karst Areas if cement does not circulate to surface on the first two casing strings, the cement on the 3rd casing string must come to surface.
 - ❖ **Special Capitan Reef requirements:** Ensure freshwater based mud is used across the Capitan Interval.
3. The minimum required fill of cement behind the **8-5/8** inch intermediate casing (*set at 3470' per BLM geologist*) is:
- Cement should tie-back at least **50 feet** on top of Capitan Reef top or **200 feet** into the previous casing, whichever is greater. If cement does not circulate see B.1.a, c-d above. **Wait on cement (WOC) time for a primary cement job is to include the lead cement slurry due to cave/karst, Capitan Reef, or potash.**

Operator has proposed to pump down Intermediate 1 X Intermediate 2 annulus after primary cementing stage. Operator must run Echo-meter to verify Cement Slurry/Fluid top in the annulus OR operator shall run a CBL from TD of the Intermediate 2 casing to tieback requirements listed above after the second stage BH to verify TOC. Submit results to the BLM. No displacement fluid/wash out shall be utilized at the top of the cement slurry between second stage BH and top out. Operator must use a limited flush fluid volume of 1 bbl following backside cementing procedures.

If cement does not reach surface, the next casing string must come to surface.

4. The minimum required fill of cement behind the **5-1/2** inch production casing is:
- Cement should tie-back at least **200 feet** into previous casing string. Operator shall provide method of verification. **Wait on cement (WOC) time for a primary cement job is to include the lead cement slurry due to cave/karst, Capitan Reef, or potash.**

C. PRESSURE CONTROL

1. Variance approved to use flex line from BOP to choke manifold. Manufacturer's specification to be readily available. No external damage to flex line. Flex line to be installed as straight as possible (no hard bends).
2. Operator has proposed a multi-bowl wellhead assembly. Minimum working pressure of the blowout preventer (BOP) and related equipment (BOPE) required for drilling below the surface casing shoe shall be **5000 (5M)** psi.
 - a. Wellhead shall be installed by manufacturer's representatives, submit documentation with subsequent sundry.
 - b. If the welding is performed by a third party, the manufacturer's representative shall monitor the temperature to verify that it does not exceed the maximum temperature of the seal.
 - c. Manufacturer representative shall install the test plug for the initial BOP test.
 - d. If the cement does not circulate and one-inch operations would have been possible with a standard wellhead, the well head shall be cut off, cementing operations performed and another wellhead installed.
 - e. Whenever any seal subject to test pressure is broken, all the tests in 43 CFR 3172 must be followed.

D. SPECIAL REQUIREMENT (S)

Communitization Agreement

- The operator will submit a Communitization Agreement to the Santa Fe Office, 301 Dinosaur Trail Santa Fe, New Mexico 87508, at least 90 days before the anticipated date of first production from a well subject to a spacing order issued by the New Mexico Oil Conservation Division. The Communitization Agreement will include the signatures of all working interest owners in all Federal and Indian leases subject to the Communitization Agreement (i.e., operating rights owners and lessees of record), or certification that the operator has obtained the written signatures of all such owners and will make those signatures available to the BLM immediately upon request.
- The operator will submit an as-drilled survey well plat of the well completion, but are not limited to, those specified in 43 CFR 3171 and 3172.
- If the operator does not comply with this condition of approval, the BLM may take enforcement actions that include, but are not limited to, those specified in 43 CFR 3163.1.
- In addition, the well sign shall include the surface and bottom hole lease numbers. When the Communitization Agreement number is known, it shall also be on the sign.

BOPE Break Testing Variance

- BOPE Break Testing is ONLY permitted for intervals utilizing a 5M BOPE or less. **(Annular preventer must be tested to a minimum of 70% of BOPE working pressure and shall be higher than the MASP.)**
- BOPE Break Testing is NOT permitted to drilling the production hole section.
- Variance only pertains to the intermediate hole-sections and no deeper than the Bone Springs formation.
- While in transfer between wells, the BOPE shall be secured by the hydraulic carrier or cradle.
- Any well control event while drilling require notification to the BLM Petroleum Engineer (575-706-2779) prior to the commencement of any BOPE Break Testing operations.

- A full BOPE test is required prior to drilling the first deep intermediate hole section. If any subsequent hole interval is deeper than the first, a full BOPE test will be required. (200' TVD tolerance between intermediate shoes is allowable).
- The BLM is to be contacted (575-361-2822 Eddy County) 4 hours prior to BOPE tests.
- As a minimum, a full BOPE test shall be performed at 21-day intervals.
- In the event any repairs or replacement of the BOPE is required, the BOPE shall test as per **43 CFR 3172**.
- If in the event break testing is not utilized, then a full BOPE test would be conducted.

Offline Cementing

Contact the BLM prior to the commencement of any offline cementing procedure.

GENERAL REQUIREMENTS

The BLM is to be notified in advance for a representative to witness:

- a. Spudding well (minimum of 24 hours)
- b. Setting and/or Cementing of all casing strings (minimum of 4 hours)
- c. BOPE tests (minimum of 4 hours)

Contact Eddy County Petroleum Engineering Inspection Staff:

Email or call the Carlsbad Field Office, 620 East Greene St., Carlsbad, NM 88220;

BLM NM CFO DrillingNotifications@BLM.GOV; (575) 361-2822

1. Unless the production casing has been run and cemented or the well has been properly plugged, the drilling rig shall not be removed from over the hole without prior approval.
 - a. In the event the operator has proposed to drill multiple wells utilizing a skid/walking rig. Operator shall secure the wellbore on the current well, after installing and testing the wellhead, by installing a blind flange of like pressure rating to the wellhead and a pressure gauge that can be monitored while drilling is performed on the other well(s).
 - b. When the operator proposes to set surface casing with Spudder Rig
 - i. Notify the BLM when moving in and removing the Spudder Rig.
 - ii. Notify the BLM when moving in the 2nd Rig. Rig to be moved in within 90 days of notification that Spudder Rig has left the location.
 - iii. BOP/BOPE test to be conducted per **43 CFR 3172** as soon as 2nd Rig is rigged up on well.
2. Floor controls are required for 3M or Greater systems. These controls will be on the rig floor, unobstructed, readily accessible to the driller and will be operational at all times during drilling and/or completion activities. Rig floor is defined as the area immediately around the rotary table; the area immediately above the substructure on which the draw works are located, this does not include the dog house or stairway area.
3. For intervals in which cement to surface is required, cement to surface should be verified with a visual check and density or pH check to differentiate cement from spacer and drilling mud. The results should be documented in the driller's log and daily reports.

A. CASING

1. Changes to the approved APD casing program need prior approval if the items substituted are of lesser grade or different casing size or are Non-API. The Operator can exchange the components of the proposal with that of superior strength (i.e. changing from J-55 to N-80, or from 36# to 40#). Changes to the approved cement program need prior approval if the altered cement plan has less volume or strength or if the changes are substantial (i.e. Multistage tool, ECP, etc.). The initial wellhead installed on the well will remain on the well with spools used as needed.
2. Wait on cement (WOC) for Potash Areas: After cementing but before commencing any tests, the casing string shall stand cemented under pressure until both of the following

- conditions have been met: 1) cement reaches a minimum compressive strength of 500 psi for all cement blends of both lead and tail cement, 2) until cement has been in place at least 8 hours. WOC time will be recorded in the driller's log. The casing integrity test can be done (prior to the cement setting up) immediately after bumping the plug.
3. Wait on cement (WOC) for Water Basin: After cementing but before commencing any tests, the casing string shall stand cemented under pressure until both of the following conditions have been met: 1) cement reaches a minimum compressive strength of 500 psi at the shoe, 2) until cement has been in place at least 8 hours. WOC time will be recorded in the driller's log. See individual casing strings for details regarding lead cement slurry requirements. The casing integrity test can be done (prior to the cement setting up) immediately after bumping the plug.
 4. Provide compressive strengths including hours to reach required 500 pounds compressive strength prior to cementing each casing string. Have well specific cement details onsite prior to pumping the cement for each casing string.
 5. No pea gravel permitted for remedial or fall back remedial without prior authorization from the BLM engineer.
 6. On that portion of any well approved for a 5M BOPE system or greater, a pressure integrity test of each casing shoe shall be performed. Formation at the shoe shall be tested to a minimum of the mud weight equivalent anticipated to control the formation pressure to the next casing depth or at total depth of the well. This test shall be performed before drilling more than 20 feet of new hole.
 7. If hardband drill pipe is rotated inside casing, returns will be monitored for metal. If metal is found in samples, drill pipe will be pulled and rubber protectors which have a larger diameter than the tool joints of the drill pipe will be installed prior to continuing drilling operations.
 8. Whenever a casing string is cemented in the R-111-Q potash area, the NMOCD requirements shall be followed.

B. PRESSURE CONTROL

1. All blowout preventer (BOP) and related equipment (BOPE) shall comply with well control requirements as described in **43 CFR 3172**.
2. If a variance is approved for a flexible hose to be installed from the BOP to the choke manifold, the following requirements apply: The flex line must meet the requirements of API 16C. Check condition of flexible line from BOP to choke manifold, replace if exterior is damaged or if line fails test. Line to be as straight as possible with no hard bends and is to be anchored according to Manufacturer's requirements. The flexible hose can be exchanged with a hose of equal size and equal or greater pressure rating. Anchor requirements, specification sheet and hydrostatic pressure test certification matching the hose in service, to be onsite for review. These documents shall be posted in the company man's trailer and on the rig floor.

3. 5M or higher system requires an HCR valve, remote kill line and annular to match. The remote kill line is to be installed prior to testing the system and tested to stack pressure.
4. If the operator has proposed a multi-bowl wellhead assembly in the APD. The following requirements must be met:
 - i. Wellhead shall be installed by manufacturer's representatives, submit documentation with subsequent sundry.
 - ii. If the welding is performed by a third party, the manufacturer's representative shall monitor the temperature to verify that it does not exceed the maximum temperature of the seal.
 - iii. Manufacturer representative shall install the test plug for the initial BOP test.
 - iv. Whenever any seal subject to test pressure is broken, all the tests in 43 CFR 3172.6(b)(9) must be followed.
 - v. If the cement does not circulate and one inch operations would have been possible with a standard wellhead, the well head shall be cut off, cementing operations performed and another wellhead installed.
5. The appropriate BLM office shall be notified a minimum of 4 hours in advance for a representative to witness the tests.
 - i. In a water basin, for all casing strings utilizing slips, these are to be set as soon as the crew and rig are ready and any fallback cement remediation has been done. The casing cut-off and BOP installation can be initiated four hours after installing the slips, which will be approximately six hours after bumping the plug. For those casing strings not using slips, the minimum wait time before cut-off is eight hours after bumping the plug. BOP/BOPE testing can begin after cut-off or once cement reaches 500 psi compressive strength (including lead cement), whichever is greater. However, if the float does not hold, cut-off cannot be initiated until cement reaches 500 psi compressive strength (including lead when specified).
 - ii. In potash areas, for all casing strings utilizing slips, these are to be set as soon as the crew and rig are ready and any fallback cement remediation has been done. For all casing strings, casing cut-off and BOP installation can be initiated at twelve hours after bumping the cement plug. The BOPE test can be initiated after bumping the cement plug with the casing valve open. (only applies to single stage cement jobs, prior to the cement setting up.)
 - iii. The tests shall be done by an independent service company utilizing a test plug not a cup or J-packer and can be initiated immediately with the casing valve open. The operator also has the option of utilizing an independent tester to test without a plug (i.e. against the casing) pursuant to **43 CFR 3172** with the pressure not to exceed 70% of the burst rating for the casing. Any test against the casing must meet the WOC time for 8 hours or 500 pounds compressive strength, whichever is greater, prior to initiating the test (see casing segment as lead cement may be critical item).

- iv. The test shall be run on a 5000 psi chart for a 2-3M BOP/BOP, on a 10000 psi chart for a 5M BOP/BOPE and on a 15000 psi chart for a 10M BOP/BOPE. If a linear chart is used, it shall be a one hour chart. A circular chart shall have a maximum 2 hour clock. If a twelve hour or twenty-four hour chart is used, tester shall make a notation that it is run with a two hour clock.
- v. The results of the test shall be reported to the appropriate BLM office.
- vi. All tests are required to be recorded on a calibrated test chart. A copy of the BOP/BOPE test chart and a copy of independent service company test will be submitted to the appropriate BLM office.
- vii. The BOP/BOPE test shall include a low pressure test from 250 to 300 psi. The test will be held for a minimum of 10 minutes if test is done with a test plug and 30 minutes without a test plug. This test shall be performed prior to the test at full stack pressure.
- viii. BOP/BOPE must be tested by an independent service company within 500 feet of the top of the Wolfcamp formation if the time between the setting of the intermediate casing and reaching this depth exceeds 20 days. This test does not exclude the test prior to drilling out the casing shoe as per **43 CFR 3172**.

C. DRILLING MUD

Mud system monitoring equipment, with derrick floor indicators and visual and audio alarms, shall be operating before drilling into the Wolfcamp formation, and shall be used until production casing is run and cemented.

D. WASTE MATERIAL AND FLUIDS

All waste (i.e. drilling fluids, trash, salts, chemicals, sewage, gray water, etc.) created as a result of drilling operations and completion operations shall be safely contained and disposed of properly at a waste disposal facility. No waste material or fluid shall be disposed of on the well location or surrounding area. Porto-johns and trash containers will be on-location during fracturing operations or any other crew-intensive operations.

C-102 Submit Electronically Via OCD Permitting	State of New Mexico Energy, Minerals & Natural Resources Department OIL CONSERVATION DIVISION	Revised July 9, 2024 Submittal Type: <input checked="" type="checkbox"/> Initial Submittal <input type="checkbox"/> Amended Report <input type="checkbox"/> As Drilled
---	--	--

WELL LOCATION INFORMATION

API Number APD # 10400054930	Pool Code 49622	Pool Name Parkway; Bone Spring
Property Code	Property Name SILVER BAR 35-36 FED STATE COM	Well Number 133H
OGRID No. 372165	Operator Name PERMIAN RESOURCES OPERATING, LLC	Ground Level Elevation 3,328.00'
Surface Owner: <input type="checkbox"/> State <input type="checkbox"/> Fee <input type="checkbox"/> Tribal <input checked="" type="checkbox"/> Federal		Mineral Owner: <input checked="" type="checkbox"/> State <input type="checkbox"/> Fee <input type="checkbox"/> Tribal <input checked="" type="checkbox"/> Federal

Surface Location

UL	Section	Township	Range	Lot	Ft. from N/S	Ft. from E/W	Latitude	Longitude	County
P	34	19S	29E		1,054' FSL	359' FEL	32.612808°	-104.055324°	EDDY

Bottom Hole Location

UL	Section	Township	Range	Lot	Ft. from N/S	Ft. from E/W	Latitude	Longitude	County
I	36	19S	29E		2,310' FSL	100' FEL	32.616039°	-104.020153°	EDDY

Dedicated Acres 320	Infill or Defining Well Defining	Defining Well API	Overlapping Spacing Unit (Y/N)	Consolidation Code
Order Numbers.			Well setbacks are under Common Ownership: <input type="checkbox"/> Yes <input type="checkbox"/> No	

Kick Off Point (KOP)

UL	Section	Township	Range	Lot	Ft. from N/S	Ft. from E/W	Latitude	Longitude	County
P	34	19S	29E		1,054' FSL	359' FEL	32.612808°	-104.055324°	EDDY

First Take Point (FTP)

UL	Section	Township	Range	Lot	Ft. from N/S	Ft. from E/W	Latitude	Longitude	County
L	35	19S	29E		2,310' FSL	100' FWL	32.616256°	-104.053826°	EDDY

Last Take Point (LTP)

UL	Section	Township	Range	Lot	Ft. from N/S	Ft. from E/W	Latitude	Longitude	County
I	36	19S	29E		2,310' FSL	100' FEL	32.616039°	-104.020153°	EDDY

Unitized Area or Area of Uniform Interest	Spacing Unit Type <input type="checkbox"/> Horizontal <input type="checkbox"/> Vertical	Ground Floor Elevation:
---	---	-------------------------

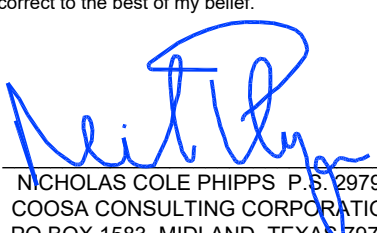
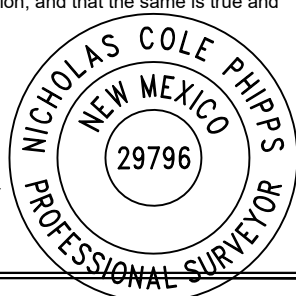
<p>OPERATOR CERTIFICATIONS</p> <p>I hereby certify that the information contained herein is true and complete to the best of my knowledge and belief, and, if the well is a vertical or directional well, that this organization either owns a working interest or unleased mineral interest in the land including the proposed bottom hole location or has a right to drill this well at this location pursuant to a contract with an owner of a working interest or unleased mineral interest, or to a voluntary pooling agreement or a compulsory pooling order heretofore entered by the division.</p> <p>If this well is a horizontal well, I further certify that this organization has received the consent of at least one lessee or owner of a working interest or unleased mineral interest in each tract (in the target pool or formation) in which any part of the well's completed interval will be located or obtained a compulsory pooling order from the division.</p>	<p>SURVEYOR CERTIFICATIONS</p> <p>I hereby certify that the well location shown on this plat was plotted from field notes of actual surveys made by me or under my supervision, and that the same is true and correct to the best of my belief.</p> <div style="text-align: center;">  NICHOLAS COLE PHIPPS P.S. 29796 COOSA CONSULTING CORPORATION PO BOX 1583, MIDLAND, TEXAS 79701 </div> <div style="text-align: right;">  </div>	
Signature <i>Cassie Evans</i>	Date 10/26/24	Signature and Seal of Professional Surveyor
Printed Name Cassie Evans	Email Address Cassie.Evans@permianres.com	Certificate Number 12177
		Date of Survey 10/2/2024

Note: No allowable will be assigned to this completion until all interests have been consolidated or a non-standard unit has been approved by the division.

ACREAGE DEDICATION PLATS

This grid represents a standard section. You may superimpose a non-standard section, or larger area, over this grid. Operators must outline the dedicated acreage in a red box, clearly show the well surface location and bottom hole location, if it is directionally drilled, with the dimensions from the section lines in the cardinal directions. If this is a horizontal wellbore show on this plat the location of the First Take Point and Last Take Point, and the point within the Completed interval (other than the First Take Point or Last Take Point) that is closest to any outer boundary of the tract.

Surveyors shall use the latest United States government survey or dependent resurvey. Well locations will be in reference to the New Mexico Principal Meridian. If the land is not surveyed, contact the OCD Engineering Bureau. Independent subdivision surveys will not be acceptable.

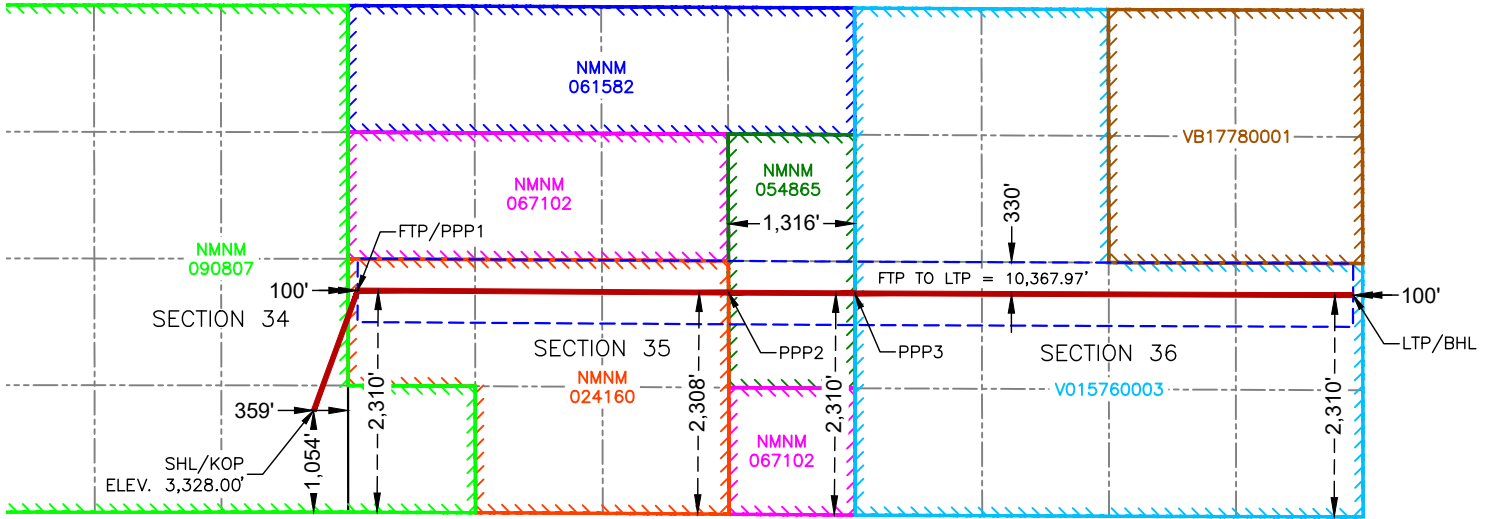

10-2-24

SURFACE HOLE LOCATION & KICK-OFF POINT
 1,054' FSL & 359' FEL
 ELEV. = 3,328.00'
 NAD 83 X = 626,939.00'
 NAD 83 Y = 586,782.44'
 NAD 83 LAT = 32.612808°
 NAD 83 LONG = -104.055324°

FIRST TAKE POINT & PENETRATION POINT 1
 2,310' FSL & 100' FWL
 NAD 83 X = 627,397.17'
 NAD 83 Y = 588,037.82'
 NAD 83 LAT = 32.616256°
 NAD 83 LONG = -104.053826°

PENETRATION POINT 2
 2,308' FSL & 1,316' FEL
 NAD 83 X = 631,259.97'
 NAD 83 Y = 588,014.60'
 NAD 83 LAT = 32.616164°
 NAD 83 LONG = -104.041280°

PENETRATION POINT 3
 2,310' FSL & 0' FWL
 NAD 83 X = 632,576.28'
 NAD 83 Y = 588,006.69'
 NAD 83 LAT = 32.616132°
 NAD 83 LONG = -104.037005°

LAST TAKE POINT & BOTTOM HOLE LOCATION
 2,310' FSL & 100' FEL
 NAD 83 X = 637,765.01'
 NAD 83 Y = 587,987.92'
 NAD 83 LAT = 32.616039°
 NAD 83 LONG = -104.020153°

Permian Resources - Silver Bar 35-36 Fed State Com 133H

1. Geologic Formations

Formation	Lithology	Elevation	TVD	Target
Rustler	Sandstone	3196	162	No
Top of Salt	Salt	2469	889	No
Tansill	Sandstone	2104	1254	No
Yates	Anhydrite/Shale	1954	1404	No
Seven Rivers	Limestone	1748	1610	No
Capitan	Sandstone	584	2774	No
Delaware Sands	Sandstone	-52	3410	No
Brushy Canyon	Sandstone	-556	3914	No
Bone Spring Lime	Limestone/Shale	-2350	5708	No
1st Bone Spring Sand	Sandstone/Limestone/Shale	-4516	7874	No
2nd Bone Spring Sand	Sandstone/Limestone/Shale	-4138	7496	No
3rd Bone Spring Sand	Sandstone/Limestone/Shale	-5436	8794	Yes
Wolfcamp	Shale	-5886	9244	No

2. Blowout Prevention

BOP installed and tested before drilling	Size?	Min. Required WP	Type	x	Tested to:
12.25	13-5/8"	5M	Annular	x	2500 psi
			Blind Ram	x	5000 psi
			Pipe Ram	x	
			Double Ram		
			Other*		
9.875	13-5/8"	5M	Annular	x	2500 psi
			Blind Ram	x	5000 psi
			Pipe Ram	x	
			Double Ram		
			Other*		
7.875	13-5/8"	5M	Annular	x	2500 psi
			Blind Ram	x	5000 psi
			Pipe Ram	x	
			Double Ram		
			Other*		

Equipment: BOPE will meet all requirements for above listed system per 43 CFR 3172. BOPE with working pressure ratings in excess of anticipated maximum surface pressure will be utilized for well control from drill out of surface casing to TMD. The system may be upgraded to a higher pressure but still tested to the working pressure listed in the table above. If the system is upgraded all of the components installed will be functional, tested, and will meet all requirements per 43 CFR 3172. The wellhead will be a multibowl speed head allowing for hangoff of intermediate casing of the surface x intermediate annulus without breaking the connection between the BOP & wellhead. A variance is requested to utilize a flexible choke line (flexhose) from the BOP to choke manifold.

Requesting Variance? YES

Variance request: Multibowl Wellhead, Flexhose, Breaktesting, Offline Cementing Variances. Attachments in Section 8.

Testing Procedure: Operator requests to ONLY test broken pressure seals per API Standard 53 and the attachments in Section 8. The BOP test shall be performed before drilling out of the surface casing shoe and will occur at a minimum: a. when initially installed, b. whenever any seal subject to test pressure is broken, c. following related repairs, d. at 21-day intervals. Testing of the ram type preventer(s) and annual type preventer(s) shall be tested per 43 CFR 3172. The BOPE configuration, choke manifold layout, and accumulator system will be in compliance with 43 CFR 3172. Bleed lines will discharge 100' from wellhead in non-H2S scenarios and 150' from wellhead in H2S scenarios.

Choke Diagram Attachment: 5M Choke Manifold

BOP Diagram Attachment: BOP Schematics

3. Casing

String	Hole Size	Casing Size	Top	Bottom	Top TVD	Bottom TVD	Length	Grade	Weight	Connection	Collapse SF	Burst SF	Joint SF Type	Joint SF	Body SF Type	Body SF
Surface	17.5	13.375	0	300	0	300	300	J55	54.5	BTC	7.62	8.26	Dry	7.81	Dry	7.33
Intermediate 1	12.25	10.75	0	790	0	790	790	J55	45.5	BTC	10.06	3.16	Dry	7.82	Dry	5.26
Intermediate 2	9.875	8.625	0	3163	0	3163	3163	P110 HS	32	MO-FXL	####	4.33	Dry	3.92	Dry	5.69
Production	7.875	5.5	0	9465	0	9228	9465	P110RY	17	GeoConn	63.09	###	Dry	5.26	Dry	5.26
Production	7.875	5.5	9465	19948	9228	228	10483	P110RY	17	GeoConn	63.09	###	Dry	5.26	Dry	5.26
BLM Min Safety Factor											1.125	1	1.6	1.6		

Non API casing spec sheets and casing design assumptions attached.

4. Cement

String	Lead/Tail	Top MD	Bottom MD	Quantity (sx)	Yield	Density	Cu Ft	Excess %	Cement Type	Additives
Surface	Tail	0	300	240	1.34	14.8	320	50%	Class C	Accelerator
Intermediate 1	Lead	0	630	100	1.88	12.9	170	50%	Class C	EconoCem-HLC + 5% Salt + 5% Kol-Seal
Intermediate 1	Tail	630	790	40	1.34	14.8	50	50%	Class C	Retarder
Intermediate 2	Lead	0	2530	150	2.96	11	440	50%	Class C	EconoCem-HLC + 5% Salt + 5% Kol-Seal
Intermediate 2	Tail	2530	3163	80	1.33	14.8	100	25%	Class C	Salt
Production	Lead	2663	7601	490	2.41	11.5	1170	40%	Class H	POZ, Extender, Fluid Loss, Dispersant, Retarder
Production	Tail	7601	19948	1550	1.73	12.5	2680	25%	Class H	POZ, Extender, Fluid Loss, Dispersant, Retarder

Permian Resources requests to pump a two-stage cement job on the 8-5/8" intermediate casing string with the first stage being pumped conventionally with the calculated top of cement at the Cherry Canyon and the second stage performed as a bradenhead squeeze with planned cement from the Brushy Canyon to surface. If cement is not visually confirmed to circulate to surface, the final cement top after the second stage job will be verified by Echo-meter. If necessary, a top out consisting of 1,500 sack of Class C cement + 3% Salt + Bentonite Gel (2.30 yld, 12.9 ppg) will be executed as a contingency. If cement is still unable to circulate to surface, another Echo-meter run will be performed for cement top verification.

Permian Resources will include the Echo-meter verified fluid top and the volume of displacement fluid above the cement slurry in the annulus in all post-drill sundries on wells utilizing this cement program.

Permian Resources will report to the BLM the volume of fluid (limited to 5 bbls) used to flush intermediate casing valves following backside cementing procedures.

Permian Resources requests to pump an Optional Lead if well conditions dictate in an attempt to bring cement inside the surface casing. If cement reaches the desired height, the BLM will be notified and the second stage bradenhead squeeze and subsequent TOC verification will be negated.

Permian Resources requests the option to conduct the bradenhead squeeze and TOC verification offline as per standard approval from BLM when unplanned remediation is needed and batch drilling is approved. In the event the bradenhead is conducted, we will ensure the first stage cement job is cemented properly and the well is static with floats holding and no pressure on the csg annulus as with all other casing strings where batch drilling operations occur before moving off the rig. The TA cap will also be installed per Cactus procedure and pressure inside the casing will be monitored via the valve on the TA cap as per standard batch drilling ops.

5. Circulating Medium

Mud System Type: Closed

Will an air or gas system be used: No

Describe what will be on location to control well or mitigate other conditions: Sufficient quantities of mud materials will be on the well site at all times for the purpose of assuring well control and maintaining wellbore integrity. Surface interval will employ fresh water mud. The intermediate hole will utilize a saturated brine fluid to inhibit salt washout. The production hole will employ brine based and oil base fluid to inhibit formation reactivity and of the appropriate density to maintain well control.

Describe the mud monitoring system utilized: Centrifuge separation system. Open tank monitoring with EDR will be used for drilling fluids and return volumes. Open tank monitoring will be used for cement and cuttings return volumes. Mud properties will be monitored at least every 24 hours using industry accepted mud check practices.

Cuttings Volume: 7850 Cu Ft

Circulating Medium Table

Top Depth	Bottom Depth	Mud Type	Min Weight	Max Weight
0	300	Spud Mud	8.6	9.5
300	790	Salt Saturated	10	10
790	3163	Fresh Water	8.6	9.5
3163	9465	Oil Based Mud	9	10

6. Test, Logging, Coring

List of production tests including testing procedures, equipment and safety measures:

Will utilize MWD/LWD from intermediate hole to TD of the well.

List of open and cased hole logs run in the well:

DIRECTIONAL SURVEY

Coring operation description for the well:

N/A

7. Pressure

Anticipated Bottom Hole Pressure	120	psi
Anticipated Surface Pressure	68	psi
Anticipated Bottom Hole Temperature	68	°F
Anticipated Abnormal pressure, temp, or geo hazards	No	

NEW MEXICO

(SP) EDDY

SILVER BAR

SILVER BAR 35-36 FED STATE COM 133H

owb

Plan: PWP0

Standard Planning Report - Geographic

23 October, 2024

Planning Report - Geographic

Database:	Compass_17	Local Co-ordinate Reference:	Well SILVER BAR 35-36 FED STATE COM 133H
Company:	NEW MEXICO	TVD Reference:	kb @ 3358.0usft
Project:	(SP) EDDY	MD Reference:	kb @ 3358.0usft
Site:	SILVER BAR	North Reference:	Grid
Well:	SILVER BAR 35-36 FED STATE COM 133H	Survey Calculation Method:	Minimum Curvature
Wellbore:	owb		
Design:	PWP0		

Project	(SP) EDDY		
Map System:	US State Plane 1983	System Datum:	Mean Sea Level
Geo Datum:	North American Datum 1983		
Map Zone:	New Mexico Eastern Zone		

Site	SILVER BAR		
Site Position:		Northing:	586,697.82 usft
From:	Map	Easting:	626,938.15 usft
Position Uncertainty:	0.0 usft	Slot Radius:	13-3/16 "
		Latitude:	32° 36' 45.273 N
		Longitude:	104° 3' 19.180 W

Well	SILVER BAR 35-36 FED STATE COM 133H		
Well Position	+N/-S	0.0 usft	Northing: 586,782.44 usft
	+E/-W	0.0 usft	Easting: 626,939.00 usft
Position Uncertainty	0.0 usft	Wellhead Elevation:	usft
Grid Convergence:	0.15 °	Latitude:	32° 36' 46.111 N
		Longitude:	104° 3' 19.168 W
		Ground Level:	3,328.0 usft

Wellbore	owb				
Magnetics	Model Name	Sample Date	Declination (°)	Dip Angle (°)	Field Strength (nT)
	IGRF200510	12/31/2009	8.00	60.52	48,974.09686731

Design	PWP0			
Audit Notes:				
Version:	Phase:	PROTOTYPE	Tie On Depth:	0.0
Vertical Section:	Depth From (TVD) (usft)	+N/-S (usft)	+E/-W (usft)	Direction (°)
	0.0	0.0	0.0	83.65

Plan Survey Tool Program	Date	10/23/2024		
Depth From (usft)	Depth To (usft)	Survey (Wellbore)	Tool Name	Remarks
1	0.0	19,947.8 PWP0 (owb)	MWD	OWSG_Rev2_ MWD - Star

Planning Report - Geographic

Database:	Compass_17	Local Co-ordinate Reference:	Well SILVER BAR 35-36 FED STATE COM 133H
Company:	NEW MEXICO	TVD Reference:	kb @ 3358.0usft
Project:	(SP) EDDY	MD Reference:	kb @ 3358.0usft
Site:	SILVER BAR	North Reference:	Grid
Well:	SILVER BAR 35-36 FED STATE COM 133H	Survey Calculation Method:	Minimum Curvature
Wellbore:	owb		
Design:	PWP0		

Plan Sections										
Measured Depth (usft)	Inclination (°)	Azimuth (°)	Vertical Depth (usft)	+N/-S (usft)	+E/-W (usft)	Dogleg Rate (°/100usft)	Build Rate (°/100usft)	Turn Rate (°/100usft)	TFO (°)	Target
0.0	0.00	0.00	0.0	0.0	0.0	0.00	0.00	0.00	0.00	
2,000.0	0.00	0.00	2,000.0	0.0	0.0	0.00	0.00	0.00	0.00	
2,750.0	15.00	2.65	2,741.5	97.5	4.5	2.00	2.00	0.00	2.65	
6,851.3	15.00	2.65	6,703.0	1,157.9	53.7	0.00	0.00	0.00	0.00	
7,601.3	0.00	0.00	7,444.5	1,255.4	58.2	2.00	-2.00	0.00	180.00	
8,907.3	0.00	0.00	8,750.5	1,255.4	58.2	0.00	0.00	0.00	0.00	
9,657.3	90.00	90.27	9,228.0	1,253.2	535.7	12.00	12.00	12.04	90.27	
19,947.8	90.00	90.27	9,228.0	1,205.5	10,826.0	0.00	0.00	0.00	0.00	BHL SILVER BAR 1

Planning Report - Geographic

Database:	Compass_17	Local Co-ordinate Reference:	Well SILVER BAR 35-36 FED STATE COM 133H
Company:	NEW MEXICO	TVD Reference:	kb @ 3358.0usft
Project:	(SP) EDDY	MD Reference:	kb @ 3358.0usft
Site:	SILVER BAR	North Reference:	Grid
Well:	SILVER BAR 35-36 FED STATE COM 133H	Survey Calculation Method:	Minimum Curvature
Wellbore:	owb		
Design:	PWP0		

Planned Survey										
Measured Depth (usft)	Inclination (°)	Azimuth (°)	Vertical Depth (usft)	+N/-S (usft)	+E/-W (usft)	Map Northing (usft)	Map Easting (usft)	Latitude	Longitude	
0.0	0.00	0.00	0.0	0.0	0.0	586,782.44	626,939.00	32° 36' 46.111 N	104° 3' 19.168 W	
100.0	0.00	0.00	100.0	0.0	0.0	586,782.44	626,939.00	32° 36' 46.111 N	104° 3' 19.168 W	
200.0	0.00	0.00	200.0	0.0	0.0	586,782.44	626,939.00	32° 36' 46.111 N	104° 3' 19.168 W	
300.0	0.00	0.00	300.0	0.0	0.0	586,782.44	626,939.00	32° 36' 46.111 N	104° 3' 19.168 W	
400.0	0.00	0.00	400.0	0.0	0.0	586,782.44	626,939.00	32° 36' 46.111 N	104° 3' 19.168 W	
500.0	0.00	0.00	500.0	0.0	0.0	586,782.44	626,939.00	32° 36' 46.111 N	104° 3' 19.168 W	
600.0	0.00	0.00	600.0	0.0	0.0	586,782.44	626,939.00	32° 36' 46.111 N	104° 3' 19.168 W	
700.0	0.00	0.00	700.0	0.0	0.0	586,782.44	626,939.00	32° 36' 46.111 N	104° 3' 19.168 W	
800.0	0.00	0.00	800.0	0.0	0.0	586,782.44	626,939.00	32° 36' 46.111 N	104° 3' 19.168 W	
900.0	0.00	0.00	900.0	0.0	0.0	586,782.44	626,939.00	32° 36' 46.111 N	104° 3' 19.168 W	
1,000.0	0.00	0.00	1,000.0	0.0	0.0	586,782.44	626,939.00	32° 36' 46.111 N	104° 3' 19.168 W	
1,100.0	0.00	0.00	1,100.0	0.0	0.0	586,782.44	626,939.00	32° 36' 46.111 N	104° 3' 19.168 W	
1,200.0	0.00	0.00	1,200.0	0.0	0.0	586,782.44	626,939.00	32° 36' 46.111 N	104° 3' 19.168 W	
1,300.0	0.00	0.00	1,300.0	0.0	0.0	586,782.44	626,939.00	32° 36' 46.111 N	104° 3' 19.168 W	
1,400.0	0.00	0.00	1,400.0	0.0	0.0	586,782.44	626,939.00	32° 36' 46.111 N	104° 3' 19.168 W	
1,500.0	0.00	0.00	1,500.0	0.0	0.0	586,782.44	626,939.00	32° 36' 46.111 N	104° 3' 19.168 W	
1,600.0	0.00	0.00	1,600.0	0.0	0.0	586,782.44	626,939.00	32° 36' 46.111 N	104° 3' 19.168 W	
1,700.0	0.00	0.00	1,700.0	0.0	0.0	586,782.44	626,939.00	32° 36' 46.111 N	104° 3' 19.168 W	
1,800.0	0.00	0.00	1,800.0	0.0	0.0	586,782.44	626,939.00	32° 36' 46.111 N	104° 3' 19.168 W	
1,900.0	0.00	0.00	1,900.0	0.0	0.0	586,782.44	626,939.00	32° 36' 46.111 N	104° 3' 19.168 W	
2,000.0	0.00	0.00	2,000.0	0.0	0.0	586,782.44	626,939.00	32° 36' 46.111 N	104° 3' 19.168 W	
Start Build 2.00										
2,100.0	2.00	2.65	2,100.0	1.7	0.1	586,784.19	626,939.08	32° 36' 46.128 N	104° 3' 19.167 W	
2,200.0	4.00	2.65	2,199.8	7.0	0.3	586,789.41	626,939.33	32° 36' 46.180 N	104° 3' 19.164 W	
2,300.0	6.00	2.65	2,299.5	15.7	0.7	586,798.12	626,939.73	32° 36' 46.266 N	104° 3' 19.159 W	
2,400.0	8.00	2.65	2,398.7	27.9	1.3	586,810.29	626,940.30	32° 36' 46.386 N	104° 3' 19.152 W	
2,500.0	10.00	2.65	2,497.5	43.5	2.0	586,825.92	626,941.02	32° 36' 46.541 N	104° 3' 19.143 W	
2,600.0	12.00	2.65	2,595.6	62.5	2.9	586,844.98	626,941.90	32° 36' 46.729 N	104° 3' 19.132 W	
2,700.0	14.00	2.65	2,693.1	85.0	3.9	586,867.45	626,942.94	32° 36' 46.952 N	104° 3' 19.119 W	
2,750.0	15.00	2.65	2,741.5	97.5	4.5	586,879.95	626,943.52	32° 36' 47.075 N	104° 3' 19.112 W	
Start 4101.3 hold at 2750.0 MD										
2,800.0	15.00	2.65	2,789.8	110.4	5.1	586,892.88	626,944.12	32° 36' 47.203 N	104° 3' 19.104 W	
2,900.0	15.00	2.65	2,886.4	136.3	6.3	586,918.73	626,945.32	32° 36' 47.459 N	104° 3' 19.090 W	
3,000.0	15.00	2.65	2,982.9	162.1	7.5	586,944.59	626,946.52	32° 36' 47.715 N	104° 3' 19.075 W	
3,100.0	15.00	2.65	3,079.5	188.0	8.7	586,970.44	626,947.72	32° 36' 47.971 N	104° 3' 19.060 W	
3,200.0	15.00	2.65	3,176.1	213.9	9.9	586,996.30	626,948.92	32° 36' 48.226 N	104° 3' 19.045 W	
3,300.0	15.00	2.65	3,272.7	239.7	11.1	587,022.15	626,950.12	32° 36' 48.482 N	104° 3' 19.030 W	
3,400.0	15.00	2.65	3,369.3	265.6	12.3	587,048.01	626,951.32	32° 36' 48.738 N	104° 3' 19.016 W	
3,500.0	15.00	2.65	3,465.9	291.4	13.5	587,073.86	626,952.51	32° 36' 48.994 N	104° 3' 19.001 W	
3,600.0	15.00	2.65	3,562.5	317.3	14.7	587,099.71	626,953.71	32° 36' 49.250 N	104° 3' 18.986 W	
3,700.0	15.00	2.65	3,659.1	343.1	15.9	587,125.57	626,954.91	32° 36' 49.505 N	104° 3' 18.971 W	
3,800.0	15.00	2.65	3,755.7	369.0	17.1	587,151.42	626,956.11	32° 36' 49.761 N	104° 3' 18.956 W	
3,900.0	15.00	2.65	3,852.3	394.8	18.3	587,177.28	626,957.31	32° 36' 50.017 N	104° 3' 18.942 W	
4,000.0	15.00	2.65	3,948.9	420.7	19.5	587,203.13	626,958.51	32° 36' 50.273 N	104° 3' 18.927 W	
4,100.0	15.00	2.65	4,045.5	446.5	20.7	587,228.98	626,959.71	32° 36' 50.529 N	104° 3' 18.912 W	
4,200.0	15.00	2.65	4,142.1	472.4	21.9	587,254.84	626,960.90	32° 36' 50.785 N	104° 3' 18.897 W	
4,300.0	15.00	2.65	4,238.6	498.2	23.1	587,280.69	626,962.10	32° 36' 51.040 N	104° 3' 18.882 W	
4,400.0	15.00	2.65	4,335.2	524.1	24.3	587,306.55	626,963.30	32° 36' 51.296 N	104° 3' 18.868 W	
4,500.0	15.00	2.65	4,431.8	550.0	25.5	587,332.40	626,964.50	32° 36' 51.552 N	104° 3' 18.853 W	
4,600.0	15.00	2.65	4,528.4	575.8	26.7	587,358.26	626,965.70	32° 36' 51.808 N	104° 3' 18.838 W	
4,700.0	15.00	2.65	4,625.0	601.7	27.9	587,384.11	626,966.90	32° 36' 52.064 N	104° 3' 18.823 W	
4,800.0	15.00	2.65	4,721.6	627.5	29.1	587,409.96	626,968.10	32° 36' 52.319 N	104° 3' 18.808 W	
4,900.0	15.00	2.65	4,818.2	653.4	30.3	587,435.82	626,969.29	32° 36' 52.575 N	104° 3' 18.794 W	

Planning Report - Geographic

Database:	Compass_17	Local Co-ordinate Reference:	Well SILVER BAR 35-36 FED STATE COM 133H
Company:	NEW MEXICO	TVD Reference:	kb @ 3358.0usft
Project:	(SP) EDDY	MD Reference:	kb @ 3358.0usft
Site:	SILVER BAR	North Reference:	Grid
Well:	SILVER BAR 35-36 FED STATE COM 133H	Survey Calculation Method:	Minimum Curvature
Wellbore:	owb		
Design:	PWP0		

Planned Survey										
Measured Depth (usft)	Inclination (°)	Azimuth (°)	Vertical Depth (usft)	+N/-S (usft)	+E/-W (usft)	Map Northing (usft)	Map Easting (usft)	Latitude	Longitude	
5,000.0	15.00	2.65	4,914.8	679.2	31.5	587,461.67	626,970.49	32° 36' 52.831 N	104° 3' 18.779 W	
5,100.0	15.00	2.65	5,011.4	705.1	32.7	587,487.53	626,971.69	32° 36' 53.087 N	104° 3' 18.764 W	
5,200.0	15.00	2.65	5,108.0	730.9	33.9	587,513.38	626,972.89	32° 36' 53.343 N	104° 3' 18.749 W	
5,300.0	15.00	2.65	5,204.6	756.8	35.1	587,539.23	626,974.09	32° 36' 53.598 N	104° 3' 18.734 W	
5,400.0	15.00	2.65	5,301.2	782.6	36.3	587,565.09	626,975.29	32° 36' 53.854 N	104° 3' 18.720 W	
5,500.0	15.00	2.65	5,397.8	808.5	37.5	587,590.94	626,976.49	32° 36' 54.110 N	104° 3' 18.705 W	
5,600.0	15.00	2.65	5,494.4	834.4	38.7	587,616.80	626,977.69	32° 36' 54.366 N	104° 3' 18.690 W	
5,700.0	15.00	2.65	5,590.9	860.2	39.9	587,642.65	626,978.88	32° 36' 54.622 N	104° 3' 18.675 W	
5,800.0	15.00	2.65	5,687.5	886.1	41.1	587,668.50	626,980.08	32° 36' 54.877 N	104° 3' 18.660 W	
5,900.0	15.00	2.65	5,784.1	911.9	42.3	587,694.36	626,981.28	32° 36' 55.133 N	104° 3' 18.645 W	
6,000.0	15.00	2.65	5,880.7	937.8	43.5	587,720.21	626,982.48	32° 36' 55.389 N	104° 3' 18.631 W	
6,100.0	15.00	2.65	5,977.3	963.6	44.7	587,746.07	626,983.68	32° 36' 55.645 N	104° 3' 18.616 W	
6,200.0	15.00	2.65	6,073.9	989.5	45.9	587,771.92	626,984.88	32° 36' 55.901 N	104° 3' 18.601 W	
6,300.0	15.00	2.65	6,170.5	1,015.3	47.1	587,797.78	626,986.08	32° 36' 56.156 N	104° 3' 18.586 W	
6,400.0	15.00	2.65	6,267.1	1,041.2	48.3	587,823.63	626,987.27	32° 36' 56.412 N	104° 3' 18.571 W	
6,500.0	15.00	2.65	6,363.7	1,067.0	49.5	587,849.48	626,988.47	32° 36' 56.668 N	104° 3' 18.557 W	
6,600.0	15.00	2.65	6,460.3	1,092.9	50.7	587,875.34	626,989.67	32° 36' 56.924 N	104° 3' 18.542 W	
6,700.0	15.00	2.65	6,556.9	1,118.7	51.9	587,901.19	626,990.87	32° 36' 57.180 N	104° 3' 18.527 W	
6,800.0	15.00	2.65	6,653.5	1,144.6	53.1	587,927.05	626,992.07	32° 36' 57.435 N	104° 3' 18.512 W	
6,851.3	15.00	2.65	6,703.0	1,157.9	53.7	587,940.31	626,992.68	32° 36' 57.567 N	104° 3' 18.505 W	
Start Drop -2.00										
6,900.0	14.03	2.65	6,750.2	1,170.1	54.2	587,952.50	626,993.25	32° 36' 57.687 N	104° 3' 18.498 W	
7,000.0	12.03	2.65	6,847.6	1,192.6	55.3	587,975.01	626,994.29	32° 36' 57.910 N	104° 3' 18.485 W	
7,100.0	10.03	2.65	6,945.7	1,211.7	56.2	587,994.12	626,995.18	32° 36' 58.099 N	104° 3' 18.474 W	
7,200.0	8.03	2.65	7,044.5	1,227.3	56.9	588,009.79	626,995.90	32° 36' 58.254 N	104° 3' 18.465 W	
7,300.0	6.03	2.65	7,143.7	1,239.6	57.5	588,022.01	626,996.47	32° 36' 58.375 N	104° 3' 18.458 W	
7,400.0	4.03	2.65	7,243.3	1,248.3	57.9	588,030.76	626,996.88	32° 36' 58.462 N	104° 3' 18.453 W	
7,500.0	2.03	2.65	7,343.2	1,253.6	58.1	588,036.03	626,997.12	32° 36' 58.514 N	104° 3' 18.450 W	
7,601.3	0.00	0.00	7,444.5	1,255.4	58.2	588,037.82	626,997.20	32° 36' 58.531 N	104° 3' 18.449 W	
Start 1306.0 hold at 7601.3 MD										
7,700.0	0.00	0.00	7,543.2	1,255.4	58.2	588,037.82	626,997.20	32° 36' 58.531 N	104° 3' 18.449 W	
7,800.0	0.00	0.00	7,643.2	1,255.4	58.2	588,037.82	626,997.20	32° 36' 58.531 N	104° 3' 18.449 W	
7,900.0	0.00	0.00	7,743.2	1,255.4	58.2	588,037.82	626,997.20	32° 36' 58.531 N	104° 3' 18.449 W	
8,000.0	0.00	0.00	7,843.2	1,255.4	58.2	588,037.82	626,997.20	32° 36' 58.531 N	104° 3' 18.449 W	
8,100.0	0.00	0.00	7,943.2	1,255.4	58.2	588,037.82	626,997.20	32° 36' 58.531 N	104° 3' 18.449 W	
8,200.0	0.00	0.00	8,043.2	1,255.4	58.2	588,037.82	626,997.20	32° 36' 58.531 N	104° 3' 18.449 W	
8,300.0	0.00	0.00	8,143.2	1,255.4	58.2	588,037.82	626,997.20	32° 36' 58.531 N	104° 3' 18.449 W	
8,400.0	0.00	0.00	8,243.2	1,255.4	58.2	588,037.82	626,997.20	32° 36' 58.531 N	104° 3' 18.449 W	
8,500.0	0.00	0.00	8,343.2	1,255.4	58.2	588,037.82	626,997.20	32° 36' 58.531 N	104° 3' 18.449 W	
8,600.0	0.00	0.00	8,443.2	1,255.4	58.2	588,037.82	626,997.20	32° 36' 58.531 N	104° 3' 18.449 W	
8,700.0	0.00	0.00	8,543.2	1,255.4	58.2	588,037.82	626,997.20	32° 36' 58.531 N	104° 3' 18.449 W	
8,800.0	0.00	0.00	8,643.2	1,255.4	58.2	588,037.82	626,997.20	32° 36' 58.531 N	104° 3' 18.449 W	
8,907.3	0.00	0.00	8,750.5	1,255.4	58.2	588,037.82	626,997.20	32° 36' 58.531 N	104° 3' 18.449 W	
Start DLS 12.00 TFO 90.27										
8,925.0	2.12	90.27	8,768.2	1,255.4	58.5	588,037.82	626,997.53	32° 36' 58.531 N	104° 3' 18.445 W	
8,950.0	5.12	90.27	8,793.1	1,255.4	60.1	588,037.81	626,999.11	32° 36' 58.531 N	104° 3' 18.427 W	
8,975.0	8.12	90.27	8,817.9	1,255.4	63.0	588,037.80	627,001.99	32° 36' 58.531 N	104° 3' 18.393 W	
9,000.0	11.12	90.27	8,842.6	1,255.3	67.2	588,037.78	627,006.17	32° 36' 58.531 N	104° 3' 18.344 W	
9,025.0	14.12	90.27	8,867.0	1,255.3	72.6	588,037.76	627,011.63	32° 36' 58.530 N	104° 3' 18.280 W	
9,050.0	17.12	90.27	8,891.1	1,255.3	79.4	588,037.73	627,018.36	32° 36' 58.530 N	104° 3' 18.201 W	
9,075.0	20.12	90.27	8,914.7	1,255.2	87.3	588,037.69	627,026.34	32° 36' 58.529 N	104° 3' 18.108 W	
9,100.0	23.12	90.27	8,938.0	1,255.2	96.6	588,037.65	627,035.55	32° 36' 58.529 N	104° 3' 18.000 W	
9,125.0	26.12	90.27	8,960.7	1,255.2	107.0	588,037.60	627,045.97	32° 36' 58.528 N	104° 3' 17.879 W	

Planning Report - Geographic

Database:	Compass_17	Local Co-ordinate Reference:	Well SILVER BAR 35-36 FED STATE COM 133H
Company:	NEW MEXICO	TVD Reference:	kb @ 3358.0usft
Project:	(SP) EDDY	MD Reference:	kb @ 3358.0usft
Site:	SILVER BAR	North Reference:	Grid
Well:	SILVER BAR 35-36 FED STATE COM 133H	Survey Calculation Method:	Minimum Curvature
Wellbore:	owb		
Design:	PWP0		

Planned Survey										
Measured Depth (usft)	Inclination (°)	Azimuth (°)	Vertical Depth (usft)	+N/-S (usft)	+E/-W (usft)	Map Northing (usft)	Map Easting (usft)	Latitude	Longitude	
9,150.0	29.12	90.27	8,982.9	1,255.1	118.6	588,037.54	627,057.56	32° 36' 58.527 N	104° 3' 17.743 W	
9,175.0	32.12	90.27	9,004.4	1,255.0	131.3	588,037.48	627,070.29	32° 36' 58.526 N	104° 3' 17.594 W	
9,200.0	35.12	90.27	9,025.2	1,255.0	145.1	588,037.42	627,084.13	32° 36' 58.525 N	104° 3' 17.432 W	
9,225.0	38.12	90.27	9,045.3	1,254.9	160.0	588,037.35	627,099.04	32° 36' 58.524 N	104° 3' 17.258 W	
9,250.0	41.12	90.27	9,064.5	1,254.8	176.0	588,037.28	627,114.98	32° 36' 58.523 N	104° 3' 17.072 W	
9,275.0	44.12	90.27	9,082.9	1,254.8	192.9	588,037.20	627,131.91	32° 36' 58.522 N	104° 3' 16.874 W	
9,300.0	47.12	90.27	9,100.4	1,254.7	210.8	588,037.12	627,149.78	32° 36' 58.521 N	104° 3' 16.665 W	
9,325.0	50.12	90.27	9,116.9	1,254.6	229.5	588,037.03	627,168.53	32° 36' 58.519 N	104° 3' 16.446 W	
9,350.0	53.12	90.27	9,132.4	1,254.5	249.1	588,036.94	627,188.13	32° 36' 58.518 N	104° 3' 16.217 W	
9,375.0	56.12	90.27	9,146.9	1,254.4	269.5	588,036.84	627,208.51	32° 36' 58.516 N	104° 3' 15.978 W	
9,400.0	59.12	90.27	9,160.3	1,254.3	290.6	588,036.75	627,229.62	32° 36' 58.515 N	104° 3' 15.731 W	
9,425.0	62.12	90.27	9,172.5	1,254.2	312.4	588,036.65	627,251.40	32° 36' 58.513 N	104° 3' 15.477 W	
9,450.0	65.12	90.27	9,183.7	1,254.1	334.8	588,036.54	627,273.79	32° 36' 58.512 N	104° 3' 15.215 W	
9,475.0	68.12	90.27	9,193.6	1,254.0	357.7	588,036.44	627,296.74	32° 36' 58.510 N	104° 3' 14.947 W	
9,500.0	71.12	90.27	9,202.3	1,253.9	381.2	588,036.33	627,320.17	32° 36' 58.508 N	104° 3' 14.673 W	
9,525.0	74.12	90.27	9,209.7	1,253.8	405.0	588,036.22	627,344.03	32° 36' 58.507 N	104° 3' 14.394 W	
9,550.0	77.12	90.27	9,216.0	1,253.7	429.2	588,036.10	627,368.24	32° 36' 58.505 N	104° 3' 14.111 W	
9,575.0	80.12	90.27	9,220.9	1,253.5	453.7	588,035.99	627,392.75	32° 36' 58.503 N	104° 3' 13.824 W	
9,600.0	83.12	90.27	9,224.5	1,253.4	478.5	588,035.88	627,417.48	32° 36' 58.501 N	104° 3' 13.535 W	
9,625.0	86.12	90.27	9,226.9	1,253.3	503.4	588,035.76	627,442.36	32° 36' 58.499 N	104° 3' 13.244 W	
9,650.0	89.12	90.27	9,227.9	1,253.2	528.3	588,035.64	627,467.34	32° 36' 58.498 N	104° 3' 12.952 W	
9,657.3	90.00	90.27	9,228.0	1,253.2	535.7	588,035.61	627,474.66	32° 36' 58.497 N	104° 3' 12.866 W	
Start 10290.5 hold at 9657.3 MD										
9,700.0	90.00	90.27	9,228.0	1,253.0	578.3	588,035.41	627,517.34	32° 36' 58.494 N	104° 3' 12.367 W	
9,800.0	90.00	90.27	9,228.0	1,252.5	678.3	588,034.95	627,617.34	32° 36' 58.487 N	104° 3' 11.198 W	
9,900.0	90.00	90.27	9,228.0	1,252.0	778.3	588,034.49	627,717.34	32° 36' 58.480 N	104° 3' 10.029 W	
10,000.0	90.00	90.27	9,228.0	1,251.6	878.3	588,034.02	627,817.34	32° 36' 58.473 N	104° 3' 8.860 W	
10,100.0	90.00	90.27	9,228.0	1,251.1	978.3	588,033.56	627,917.33	32° 36' 58.465 N	104° 3' 7.691 W	
10,200.0	90.00	90.27	9,228.0	1,250.7	1,078.3	588,033.10	628,017.33	32° 36' 58.458 N	104° 3' 6.522 W	
10,300.0	90.00	90.27	9,228.0	1,250.2	1,178.3	588,032.63	628,117.33	32° 36' 58.451 N	104° 3' 5.352 W	
10,400.0	90.00	90.27	9,228.0	1,249.7	1,278.3	588,032.17	628,217.33	32° 36' 58.444 N	104° 3' 4.183 W	
10,500.0	90.00	90.27	9,228.0	1,249.3	1,378.3	588,031.71	628,317.33	32° 36' 58.436 N	104° 3' 3.014 W	
10,600.0	90.00	90.27	9,228.0	1,248.8	1,478.3	588,031.24	628,417.33	32° 36' 58.429 N	104° 3' 1.845 W	
10,700.0	90.00	90.27	9,228.0	1,248.3	1,578.3	588,030.78	628,517.33	32° 36' 58.422 N	104° 3' 0.676 W	
10,800.0	90.00	90.27	9,228.0	1,247.9	1,678.3	588,030.32	628,617.33	32° 36' 58.415 N	104° 2' 59.506 W	
10,900.0	90.00	90.27	9,228.0	1,247.4	1,778.3	588,029.85	628,717.33	32° 36' 58.408 N	104° 2' 58.337 W	
11,000.0	90.00	90.27	9,228.0	1,246.9	1,878.3	588,029.39	628,817.32	32° 36' 58.400 N	104° 2' 57.168 W	
11,100.0	90.00	90.27	9,228.0	1,246.5	1,978.3	588,028.92	628,917.32	32° 36' 58.393 N	104° 2' 55.999 W	
11,200.0	90.00	90.27	9,228.0	1,246.0	2,078.3	588,028.46	629,017.32	32° 36' 58.386 N	104° 2' 54.830 W	
11,300.0	90.00	90.27	9,228.0	1,245.6	2,178.3	588,028.00	629,117.32	32° 36' 58.379 N	104° 2' 53.661 W	
11,400.0	90.00	90.27	9,228.0	1,245.1	2,278.3	588,027.53	629,217.32	32° 36' 58.371 N	104° 2' 52.491 W	
11,500.0	90.00	90.27	9,228.0	1,244.6	2,378.3	588,027.07	629,317.32	32° 36' 58.364 N	104° 2' 51.322 W	
11,600.0	90.00	90.27	9,228.0	1,244.2	2,478.3	588,026.61	629,417.32	32° 36' 58.357 N	104° 2' 50.153 W	
11,700.0	90.00	90.27	9,228.0	1,243.7	2,578.3	588,026.14	629,517.32	32° 36' 58.350 N	104° 2' 48.984 W	
11,800.0	90.00	90.27	9,228.0	1,243.2	2,678.3	588,025.68	629,617.32	32° 36' 58.342 N	104° 2' 47.815 W	
11,900.0	90.00	90.27	9,228.0	1,242.8	2,778.3	588,025.22	629,717.31	32° 36' 58.335 N	104° 2' 46.645 W	
12,000.0	90.00	90.27	9,228.0	1,242.3	2,878.3	588,024.75	629,817.31	32° 36' 58.328 N	104° 2' 45.476 W	
12,100.0	90.00	90.27	9,228.0	1,241.8	2,978.3	588,024.29	629,917.31	32° 36' 58.321 N	104° 2' 44.307 W	
12,200.0	90.00	90.27	9,228.0	1,241.4	3,078.3	588,023.83	630,017.31	32° 36' 58.313 N	104° 2' 43.138 W	
12,300.0	90.00	90.27	9,228.0	1,240.9	3,178.3	588,023.36	630,117.31	32° 36' 58.306 N	104° 2' 41.969 W	
12,400.0	90.00	90.27	9,228.0	1,240.5	3,278.3	588,022.90	630,217.31	32° 36' 58.299 N	104° 2' 40.800 W	
12,500.0	90.00	90.27	9,228.0	1,240.0	3,378.3	588,022.44	630,317.31	32° 36' 58.292 N	104° 2' 39.630 W	
12,600.0	90.00	90.27	9,228.0	1,239.5	3,478.3	588,021.97	630,417.31	32° 36' 58.284 N	104° 2' 38.461 W	

Planning Report - Geographic

Database:	Compass_17	Local Co-ordinate Reference:	Well SILVER BAR 35-36 FED STATE COM 133H
Company:	NEW MEXICO	TVD Reference:	kb @ 3358.0usft
Project:	(SP) EDDY	MD Reference:	kb @ 3358.0usft
Site:	SILVER BAR	North Reference:	Grid
Well:	SILVER BAR 35-36 FED STATE COM 133H	Survey Calculation Method:	Minimum Curvature
Wellbore:	owb		
Design:	PWP0		

Planned Survey										
Measured Depth (usft)	Inclination (°)	Azimuth (°)	Vertical Depth (usft)	+N/-S (usft)	+E/-W (usft)	Map Northing (usft)	Map Easting (usft)	Latitude	Longitude	
12,700.0	90.00	90.27	9,228.0	1,239.1	3,578.3	588,021.51	630,517.31	32° 36' 58.277 N	104° 2' 37.292 W	
12,800.0	90.00	90.27	9,228.0	1,238.6	3,678.3	588,021.05	630,617.31	32° 36' 58.270 N	104° 2' 36.123 W	
12,900.0	90.00	90.27	9,228.0	1,238.1	3,778.3	588,020.58	630,717.30	32° 36' 58.262 N	104° 2' 34.954 W	
13,000.0	90.00	90.27	9,228.0	1,237.7	3,878.3	588,020.12	630,817.30	32° 36' 58.255 N	104° 2' 33.784 W	
13,100.0	90.00	90.27	9,228.0	1,237.2	3,978.3	588,019.66	630,917.30	32° 36' 58.248 N	104° 2' 32.615 W	
13,200.0	90.00	90.27	9,228.0	1,236.8	4,078.3	588,019.19	631,017.30	32° 36' 58.241 N	104° 2' 31.446 W	
13,300.0	90.00	90.27	9,228.0	1,236.3	4,178.3	588,018.73	631,117.30	32° 36' 58.233 N	104° 2' 30.277 W	
13,400.0	90.00	90.27	9,228.0	1,235.8	4,278.3	588,018.27	631,217.30	32° 36' 58.226 N	104° 2' 29.108 W	
13,443.0	90.00	90.27	9,228.0	1,235.6	4,321.3	588,018.07	631,260.27	32° 36' 58.223 N	104° 2' 28.605 W	
NMMN 054865 Entry at 13443.0 MD										
13,500.0	90.00	90.27	9,228.0	1,235.4	4,378.3	588,017.80	631,317.30	32° 36' 58.219 N	104° 2' 27.939 W	
13,600.0	90.00	90.27	9,228.0	1,234.9	4,478.3	588,017.34	631,417.30	32° 36' 58.211 N	104° 2' 26.769 W	
13,700.0	90.00	90.27	9,228.0	1,234.4	4,578.3	588,016.88	631,517.30	32° 36' 58.204 N	104° 2' 25.600 W	
13,800.0	90.00	90.27	9,228.0	1,234.0	4,678.3	588,016.41	631,617.29	32° 36' 58.197 N	104° 2' 24.431 W	
13,900.0	90.00	90.27	9,228.0	1,233.5	4,778.3	588,015.95	631,717.29	32° 36' 58.189 N	104° 2' 23.262 W	
14,000.0	90.00	90.27	9,228.0	1,233.0	4,878.3	588,015.49	631,817.29	32° 36' 58.182 N	104° 2' 22.093 W	
14,100.0	90.00	90.27	9,228.0	1,232.6	4,978.3	588,015.02	631,917.29	32° 36' 58.175 N	104° 2' 20.923 W	
14,200.0	90.00	90.27	9,228.0	1,232.1	5,078.3	588,014.56	632,017.29	32° 36' 58.167 N	104° 2' 19.754 W	
14,300.0	90.00	90.27	9,228.0	1,231.7	5,178.3	588,014.10	632,117.29	32° 36' 58.160 N	104° 2' 18.585 W	
14,400.0	90.00	90.27	9,228.0	1,231.2	5,278.3	588,013.63	632,217.29	32° 36' 58.153 N	104° 2' 17.416 W	
14,500.0	90.00	90.27	9,228.0	1,230.7	5,378.3	588,013.17	632,317.29	32° 36' 58.145 N	104° 2' 16.247 W	
14,600.0	90.00	90.27	9,228.0	1,230.3	5,478.3	588,012.71	632,417.29	32° 36' 58.138 N	104° 2' 15.078 W	
14,700.0	90.00	90.27	9,228.0	1,229.8	5,578.3	588,012.24	632,517.28	32° 36' 58.131 N	104° 2' 13.908 W	
14,760.0	90.00	90.27	9,228.0	1,229.5	5,638.3	588,011.96	632,577.25	32° 36' 58.126 N	104° 2' 13.207 W	
NMMN 054865 Exit at 14760.0 MD										
14,800.0	90.00	90.27	9,228.0	1,229.3	5,678.3	588,011.78	632,617.28	32° 36' 58.123 N	104° 2' 12.739 W	
14,900.0	90.00	90.27	9,228.0	1,228.9	5,778.3	588,011.32	632,717.28	32° 36' 58.116 N	104° 2' 11.570 W	
15,000.0	90.00	90.27	9,228.0	1,228.4	5,878.3	588,010.85	632,817.28	32° 36' 58.109 N	104° 2' 10.401 W	
15,100.0	90.00	90.27	9,228.0	1,227.9	5,978.3	588,010.39	632,917.28	32° 36' 58.101 N	104° 2' 9.232 W	
15,200.0	90.00	90.27	9,228.0	1,227.5	6,078.3	588,009.93	633,017.28	32° 36' 58.094 N	104° 2' 8.063 W	
15,300.0	90.00	90.27	9,228.0	1,227.0	6,178.3	588,009.46	633,117.28	32° 36' 58.087 N	104° 2' 6.893 W	
15,400.0	90.00	90.27	9,228.0	1,226.6	6,278.3	588,009.00	633,217.28	32° 36' 58.079 N	104° 2' 5.724 W	
15,500.0	90.00	90.27	9,228.0	1,226.1	6,378.3	588,008.53	633,317.28	32° 36' 58.072 N	104° 2' 4.555 W	
15,600.0	90.00	90.27	9,228.0	1,225.6	6,478.3	588,008.07	633,417.28	32° 36' 58.065 N	104° 2' 3.386 W	
15,700.0	90.00	90.27	9,228.0	1,225.2	6,578.3	588,007.61	633,517.27	32° 36' 58.057 N	104° 2' 2.217 W	
15,800.0	90.00	90.27	9,228.0	1,224.7	6,678.3	588,007.14	633,617.27	32° 36' 58.050 N	104° 2' 1.047 W	
15,900.0	90.00	90.27	9,228.0	1,224.2	6,778.3	588,006.68	633,717.27	32° 36' 58.042 N	104° 1' 59.878 W	
16,000.0	90.00	90.27	9,228.0	1,223.8	6,878.3	588,006.22	633,817.27	32° 36' 58.035 N	104° 1' 58.709 W	
16,100.0	90.00	90.27	9,228.0	1,223.3	6,978.3	588,005.75	633,917.27	32° 36' 58.028 N	104° 1' 57.540 W	
16,200.0	90.00	90.27	9,228.0	1,222.8	7,078.3	588,005.29	634,017.27	32° 36' 58.020 N	104° 1' 56.371 W	
16,300.0	90.00	90.27	9,228.0	1,222.4	7,178.3	588,004.83	634,117.27	32° 36' 58.013 N	104° 1' 55.202 W	
16,400.0	90.00	90.27	9,228.0	1,221.9	7,278.3	588,004.36	634,217.27	32° 36' 58.006 N	104° 1' 54.032 W	
16,500.0	90.00	90.27	9,228.0	1,221.5	7,378.3	588,003.90	634,317.27	32° 36' 57.998 N	104° 1' 52.863 W	
16,600.0	90.00	90.27	9,228.0	1,221.0	7,478.3	588,003.44	634,417.26	32° 36' 57.991 N	104° 1' 51.694 W	
16,700.0	90.00	90.27	9,228.0	1,220.5	7,578.3	588,002.97	634,517.26	32° 36' 57.983 N	104° 1' 50.525 W	
16,800.0	90.00	90.27	9,228.0	1,220.1	7,678.3	588,002.51	634,617.26	32° 36' 57.976 N	104° 1' 49.356 W	
16,900.0	90.00	90.27	9,228.0	1,219.6	7,778.3	588,002.05	634,717.26	32° 36' 57.969 N	104° 1' 48.187 W	
17,000.0	90.00	90.27	9,228.0	1,219.1	7,878.3	588,001.58	634,817.26	32° 36' 57.961 N	104° 1' 47.017 W	
17,100.0	90.00	90.27	9,228.0	1,218.7	7,978.3	588,001.12	634,917.26	32° 36' 57.954 N	104° 1' 45.848 W	
17,200.0	90.00	90.27	9,228.0	1,218.2	8,078.3	588,000.66	635,017.26	32° 36' 57.946 N	104° 1' 44.679 W	
17,300.0	90.00	90.27	9,228.0	1,217.8	8,178.3	588,000.19	635,117.26	32° 36' 57.939 N	104° 1' 43.510 W	
17,400.0	90.00	90.27	9,228.0	1,217.3	8,278.3	587,999.73	635,217.26	32° 36' 57.931 N	104° 1' 42.341 W	
17,500.0	90.00	90.27	9,228.0	1,216.8	8,378.3	587,999.27	635,317.25	32° 36' 57.924 N	104° 1' 41.171 W	

Planning Report - Geographic

Database:	Compass_17	Local Co-ordinate Reference:	Well SILVER BAR 35-36 FED STATE COM 133H
Company:	NEW MEXICO	TVD Reference:	kb @ 3358.0usft
Project:	(SP) EDDY	MD Reference:	kb @ 3358.0usft
Site:	SILVER BAR	North Reference:	Grid
Well:	SILVER BAR 35-36 FED STATE COM 133H	Survey Calculation Method:	Minimum Curvature
Wellbore:	owb		
Design:	PWP0		

Planned Survey										
Measured Depth (usft)	Inclination (°)	Azimuth (°)	Vertical Depth (usft)	+N/-S (usft)	+E/-W (usft)	Map Northing (usft)	Map Easting (usft)	Latitude	Longitude	
17,600.0	90.00	90.27	9,228.0	1,216.4	8,478.2	587,998.80	635,417.25	32° 36' 57.917 N	104° 1' 40.002 W	
17,700.0	90.00	90.27	9,228.0	1,215.9	8,578.2	587,998.34	635,517.25	32° 36' 57.909 N	104° 1' 38.833 W	
17,800.0	90.00	90.27	9,228.0	1,215.4	8,678.2	587,997.88	635,617.25	32° 36' 57.902 N	104° 1' 37.664 W	
17,900.0	90.00	90.27	9,228.0	1,215.0	8,778.2	587,997.41	635,717.25	32° 36' 57.894 N	104° 1' 36.495 W	
18,000.0	90.00	90.27	9,228.0	1,214.5	8,878.2	587,996.95	635,817.25	32° 36' 57.887 N	104° 1' 35.326 W	
18,100.0	90.00	90.27	9,228.0	1,214.0	8,978.2	587,996.49	635,917.25	32° 36' 57.879 N	104° 1' 34.156 W	
18,200.0	90.00	90.27	9,228.0	1,213.6	9,078.2	587,996.02	636,017.25	32° 36' 57.872 N	104° 1' 32.987 W	
18,300.0	90.00	90.27	9,228.0	1,213.1	9,178.2	587,995.56	636,117.25	32° 36' 57.864 N	104° 1' 31.818 W	
18,400.0	90.00	90.27	9,228.0	1,212.7	9,278.2	587,995.10	636,217.25	32° 36' 57.857 N	104° 1' 30.649 W	
18,500.0	90.00	90.27	9,228.0	1,212.2	9,378.2	587,994.63	636,317.24	32° 36' 57.850 N	104° 1' 29.480 W	
18,600.0	90.00	90.27	9,228.0	1,211.7	9,478.2	587,994.17	636,417.24	32° 36' 57.842 N	104° 1' 28.311 W	
18,700.0	90.00	90.27	9,228.0	1,211.3	9,578.2	587,993.71	636,517.24	32° 36' 57.835 N	104° 1' 27.141 W	
18,800.0	90.00	90.27	9,228.0	1,210.8	9,678.2	587,993.24	636,617.24	32° 36' 57.827 N	104° 1' 25.972 W	
18,900.0	90.00	90.27	9,228.0	1,210.3	9,778.2	587,992.78	636,717.24	32° 36' 57.820 N	104° 1' 24.803 W	
19,000.0	90.00	90.27	9,228.0	1,209.9	9,878.2	587,992.32	636,817.24	32° 36' 57.812 N	104° 1' 23.634 W	
19,100.0	90.00	90.27	9,228.0	1,209.4	9,978.2	587,991.85	636,917.24	32° 36' 57.805 N	104° 1' 22.465 W	
19,200.0	90.00	90.27	9,228.0	1,208.9	10,078.2	587,991.39	637,017.24	32° 36' 57.797 N	104° 1' 21.295 W	
19,300.0	90.00	90.27	9,228.0	1,208.5	10,178.2	587,990.93	637,117.24	32° 36' 57.790 N	104° 1' 20.126 W	
19,400.0	90.00	90.27	9,228.0	1,208.0	10,278.2	587,990.46	637,217.23	32° 36' 57.782 N	104° 1' 18.957 W	
19,500.0	90.00	90.27	9,228.0	1,207.6	10,378.2	587,990.00	637,317.23	32° 36' 57.775 N	104° 1' 17.788 W	
19,600.0	90.00	90.27	9,228.0	1,207.1	10,478.2	587,989.53	637,417.23	32° 36' 57.767 N	104° 1' 16.619 W	
19,700.0	90.00	90.27	9,228.0	1,206.6	10,578.2	587,989.07	637,517.23	32° 36' 57.760 N	104° 1' 15.450 W	
19,800.0	90.00	90.27	9,228.0	1,206.2	10,678.2	587,988.61	637,617.23	32° 36' 57.752 N	104° 1' 14.280 W	
19,900.0	90.00	90.27	9,228.0	1,205.7	10,778.2	587,988.14	637,717.23	32° 36' 57.745 N	104° 1' 13.111 W	
19,947.8	90.00	90.27	9,228.0	1,205.5	10,826.0	587,987.92	637,765.01	32° 36' 57.741 N	104° 1' 12.553 W	
TD at 19947.8										

Design Targets										
Target Name	Dip Angle (°)	Dip Dir. (°)	TVD (usft)	+N/-S (usft)	+E/-W (usft)	Northing (usft)	Easting (usft)	Latitude	Longitude	
BHL SILVER BAR 133 - hit/miss target - plan hits target center - Point	0.00	0.00	9,228.0	1,205.5	10,826.0	587,987.92	637,765.01	32° 36' 57.741 N	104° 1' 12.553 W	
FTP SILVER BAR 133 - plan misses target center by 6.6usft at 9580.4usft MD (9221.8 TVD, 1253.5 N, 459.1 E) - Point	0.00	0.00	9,228.0	1,255.4	458.2	588,037.82	627,397.17	32° 36' 58.521 N	104° 3' 13.772 W	

Planning Report - Geographic

Database:	Compass_17	Local Co-ordinate Reference:	Well SILVER BAR 35-36 FED STATE COM 133H
Company:	NEW MEXICO	TVD Reference:	kb @ 3358.0usft
Project:	(SP) EDDY	MD Reference:	kb @ 3358.0usft
Site:	SILVER BAR	North Reference:	Grid
Well:	SILVER BAR 35-36 FED STATE COM 133H	Survey Calculation Method:	Minimum Curvature
Wellbore:	owb		
Design:	PWP0		

Plan Annotations				
Measured Depth (usft)	Vertical Depth (usft)	Local Coordinates		Comment
		+N/-S (usft)	+E/-W (usft)	
2,000.0	2,000.0	0.0	0.0	Start Build 2.00
2,750.0	2,741.5	97.5	4.5	Start 4101.3 hold at 2750.0 MD
6,851.3	6,703.0	1,157.9	53.7	Start Drop -2.00
7,601.3	7,444.5	1,255.4	58.2	Start 1306.0 hold at 7601.3 MD
8,907.3	8,750.5	1,255.4	58.2	Start DLS 12.00 TFO 90.27
9,657.3	9,228.0	1,253.2	535.7	Start 10290.5 hold at 9657.3 MD
13,443.0	9,228.0	1,235.6	4,321.3	NMNM 054865 Entry at 13443.0 MD
14,760.0	9,228.0	1,229.5	5,638.3	NMNM 054865 Exit at 14760.0 MD
19,947.8	9,228.0	1,205.5	10,826.0	TD at 19947.8

NEW MEXICO

(SP) EDDY

SILVER BAR

SILVER BAR 35-36 FED STATE COM 133H

owb

PWP0

Anticollision Report

23 October, 2024

Anticollision Report

Company:	NEW MEXICO	Local Co-ordinate Reference:	Well SILVER BAR 35-36 FED STATE COM 133H
Project:	(SP) EDDY	TVD Reference:	kb @ 3358.0usft
Reference Site:	SILVER BAR	MD Reference:	kb @ 3358.0usft
Site Error:	0.0 usft	North Reference:	Grid
Reference Well:	SILVER BAR 35-36 FED STATE COM 133H	Survey Calculation Method:	Minimum Curvature
Well Error:	0.0 usft	Output errors are at	2.00 sigma
Reference Wellbore	owb	Database:	Compass_17
Reference Design:	PWP0	Offset TVD Reference:	Offset Datum

Reference	PWP0		
Filter type:	NO GLOBAL FILTER: Using user defined selection & filtering criteria		
Interpolation Method:	Stations	Error Model:	ISCWSA
Depth Range:	Unlimited	Scan Method:	Closest Approach 3D
Results Limited by:	Maximum centre distance of 1,000.0usft	Error Surface:	Pedal Curve
Warning Levels Evaluated at:	2.00 Sigma	Casing Method:	Not applied

Survey Tool Program	Date	10/23/2024		
From (usft)	To (usft)	Survey (Wellbore)	Tool Name	Description
0.0	19,947.8	PWP0 (owb)	MWD	OWSG_Rev2_ MWD - Standard

Summary						
Site Name	Reference Measured Depth (usft)	Offset Measured Depth (usft)	Distance Between Centres (usft)	Distance Between Ellipses (usft)	Separation Factor	Warning
IRONHORSE 35-36 FED STATE						
Black Diamond 34 Fed Com 122H - AWP - FINAL MWD						Out of range
Black Diamond 34 Fed Com 132H - AWP - FINAL MWD	9,096.3	9,048.4	654.6	589.5	10.054	CC
Black Diamond 34 Fed Com 132H - AWP - FINAL MWD	9,100.0	9,048.4	654.6	589.5	10.051	ES
Black Diamond 34 Fed Com 132H - AWP - FINAL MWD	9,125.0	9,053.5	655.2	589.9	10.043	SF
IRONHORSE 35 FED 131H - OWB - PWP0						Out of range
IRONHORSE 35 FED 132H - OWB - PWP0						Out of range
IRONHORSE 35 FED 171H - OWB - PWP0						Out of range
IRONHORSE 35 FED 172H - OWB - PWP0	8,300.0	8,201.5	661.2	602.1	11.198	CC
IRONHORSE 35 FED 172H - OWB - PWP0	19,947.8	19,235.6	882.9	476.3	2.171	ES, SF
IRONHORSE 35 FED 201H - OWB - PWP0	9,353.1	9,196.6	987.2	921.3	14.991	CC
IRONHORSE 35 FED 201H - OWB - PWP0	19,947.8	19,830.3	992.5	474.9	1.917	ES, SF
Parkway ST 36 #1 - AWP - INC ONLY	16,733.0	9,238.0	986.8	573.9	2.390	CC, ES
Parkway ST 36 #1 - AWP - INC ONLY	16,800.0	9,238.0	989.0	574.2	2.384	SF
xxIRONHORSE 35-36 FED STATE COM 174H - OWB -	8,907.3	8,805.2	664.3	600.8	10.452	CC
xxIRONHORSE 35-36 FED STATE COM 174H - OWB -	8,925.0	8,822.9	664.4	600.7	10.433	ES
xxIRONHORSE 35-36 FED STATE COM 174H - OWB -	9,150.0	9,037.5	674.3	608.8	10.288	SF
SILVER BAR						
BLACK DIAMOND 34 FED COM 133H - AWB - AWB	2,782.6	2,767.2	48.9	29.4	2.503	CC
BLACK DIAMOND 34 FED COM 133H - AWB - AWB	2,800.0	2,784.3	49.0	29.3	2.490	ES, SF
BLACK DIAMOND 34 FED COM 134H - AWB - AWB	2,477.0	2,470.2	31.5	14.2	1.820	CC, ES, SF
XXXX SILVER BAR 35 FED ST COM 203H - OWB - PW	2,000.0	1,972.0	84.6	70.5	5.989	CC, ES
XXXX SILVER BAR 35 FED ST COM 203H - OWB - PW	2,100.0	2,072.0	86.4	71.5	5.817	SF

Offset Design: IRONHORSE 35-36 FED STATE - Black Diamond 34 Fed Com 132H - AWP - FINAL MWD													Offset Site Error:	0.0 usft
Survey Program: 15-MWD+IFR1+MS													Offset Well Error:	0.0 usft
Reference Measured Depth (usft)	Vertical Depth (usft)	Offset Measured Depth (usft)	Vertical Depth (usft)	Semi Major Axis Reference (usft)	Offset (usft)	Highside Toolface (°)	Offset Wellbore Centre +N/-S (usft)	+E/-W (usft)	Distance Between Centres (usft)	Distance Between Ellipses (usft)	Minimum Separation (usft)	Separation Factor	Warning	
7,300.0	7,143.7	7,281.4	7,239.7	32.1	26.3	7.73	2,203.7	231.8	985.9	933.4	52.47	18.790		
7,400.0	7,243.3	7,380.3	7,337.9	32.5	26.6	7.93	2,192.2	232.9	966.1	912.9	53.19	18.164		
7,500.0	7,343.2	7,460.5	7,417.6	32.8	26.9	8.14	2,183.7	235.0	950.9	897.0	53.96	17.622		
7,601.3	7,444.5	7,581.3	7,537.7	33.1	27.4	11.17	2,170.6	238.9	939.1	884.5	54.62	17.194		

CC - Min centre to center distance or convergent point, SF - min separation factor, ES - min ellipse separation

Anticollision Report

Company:	NEW MEXICO	Local Co-ordinate Reference:	Well SILVER BAR 35-36 FED STATE COM 133H
Project:	(SP) EDDY	TVD Reference:	kb @ 3358.0usft
Reference Site:	SILVER BAR	MD Reference:	kb @ 3358.0usft
Site Error:	0.0 usft	North Reference:	Grid
Reference Well:	SILVER BAR 35-36 FED STATE COM 133H	Survey Calculation Method:	Minimum Curvature
Well Error:	0.0 usft	Output errors are at	2.00 sigma
Reference Wellbore	owb	Database:	Compass_17
Reference Design:	PWP0	Offset TVD Reference:	Offset Datum

Offset Design: IRONHORSE 35-36 FED STATE - Black Diamond 34 Fed Com 132H - AWP - FINAL MWD												Offset Site Error:	0.0 usft		
Survey Program: 15-MWD+IFR1+MS												Rule Assigned:		Offset Well Error:	0.0 usft
Measured Depth (usft)	Vertical Depth (usft)	Measured Depth (usft)	Vertical Depth (usft)	Semi Reference (usft)	Major Offset (usft)	Highside Toolface (°)	Offset Wellbore Centre		Between Centres (usft)	Between Ellipses (usft)	Minimum Separation (usft)	Separation Factor	Warning		
							+N/-S (usft)	+E/-W (usft)							
7,700.0	7,543.2	7,699.6	7,654.5	33.4	27.8	11.79	2,153.6	245.7	926.1	870.8	55.24	16.764			
7,800.0	7,643.2	7,766.3	7,720.5	33.7	28.1	12.15	2,144.7	249.6	914.3	858.2	56.10	16.299			
7,900.0	7,743.2	7,848.6	7,802.2	33.9	28.4	12.54	2,136.5	254.2	905.6	848.7	56.86	15.925			
8,000.0	7,843.2	7,979.1	7,931.4	34.2	28.9	13.38	2,121.3	264.1	895.9	838.4	57.49	15.583			
8,100.0	7,943.2	8,068.7	8,020.0	34.5	29.2	13.99	2,109.8	271.1	885.2	827.0	58.26	15.193			
8,200.0	8,043.2	8,166.2	8,116.8	34.8	29.6	14.46	2,098.5	275.6	875.1	816.1	58.99	14.835			
8,300.0	8,143.2	8,269.7	8,219.6	35.1	29.9	14.81	2,087.2	278.1	865.2	805.5	59.69	14.494			
8,400.0	8,243.2	8,377.1	8,326.0	35.4	30.3	15.34	2,072.9	282.5	853.2	792.9	60.38	14.130			
8,500.0	8,343.2	8,482.7	8,474.6	35.7	30.0	14.28	2,050.6	235.1	830.5	774.9	55.54	14.953			
8,600.0	8,443.2	8,572.9	8,783.6	36.0	32.1	12.94	1,935.3	214.5	782.5	725.2	57.33	13.649			
8,700.0	8,543.2	8,920.3	8,821.3	36.3	32.2	11.06	1,922.6	188.7	740.0	680.8	59.12	12.516			
8,800.0	8,643.2	8,957.7	8,850.2	36.6	32.3	9.28	1,915.4	166.0	704.4	643.3	61.10	11.528			
8,907.3	8,750.5	8,994.3	8,877.8	36.9	32.4	7.33	1,911.1	142.5	676.1	613.1	63.04	10.726			
8,925.0	8,768.2	9,000.2	8,882.2	37.0	32.4	-83.71	1,910.7	138.6	672.5	609.2	63.31	10.622			
8,950.0	8,793.1	9,007.9	8,888.0	37.0	32.4	-84.73	1,910.3	133.5	668.0	604.3	63.68	10.489			
8,975.0	8,817.9	9,016.3	8,894.2	37.1	32.4	-85.77	1,909.9	127.9	663.9	599.9	64.01	10.372			
9,000.0	8,842.6	9,021.4	8,898.0	37.2	32.4	-86.52	1,909.8	124.4	660.6	596.3	64.32	10.270			
9,025.0	8,867.0	9,030.8	8,904.8	37.2	32.5	-87.51	1,909.6	118.0	657.9	593.3	64.57	10.189			
9,050.0	8,891.1	9,035.0	8,907.9	37.3	32.5	-88.06	1,909.6	115.1	656.0	591.2	64.80	10.124			
9,075.0	8,914.7	9,042.9	8,913.6	37.4	32.5	-88.81	1,909.6	109.6	654.9	589.9	64.98	10.078			
9,096.3	8,934.6	9,048.4	8,917.5	37.4	32.5	-89.28	1,909.7	105.7	654.6	589.5	65.11	10.054	CC		
9,100.0	8,938.0	9,048.4	8,917.5	37.5	32.5	-89.28	1,909.7	105.7	654.6	589.5	65.13	10.051	ES		
9,125.0	8,960.7	9,053.5	8,921.0	37.5	32.5	-89.63	1,909.8	102.1	655.2	589.9	65.24	10.043	SF		
9,150.0	8,982.9	9,058.1	8,924.2	37.6	32.5	-89.84	1,909.9	98.9	656.6	591.3	65.31	10.054			
9,175.0	9,004.4	9,061.9	8,926.8	37.7	32.5	-89.88	1,910.0	96.1	659.0	593.6	65.36	10.083			
9,200.0	9,025.2	9,064.6	8,928.7	37.7	32.5	-89.71	1,910.1	94.2	662.2	596.9	65.37	10.131			
9,225.0	9,045.3	9,066.5	8,930.0	37.8	32.5	-89.37	1,910.1	92.8	666.4	601.1	65.35	10.197			
9,250.0	9,064.5	9,067.4	8,930.7	37.8	32.5	-88.83	1,910.2	92.1	671.5	606.2	65.32	10.280			
9,275.0	9,082.9	9,067.5	8,930.7	37.9	32.5	-88.11	1,910.2	92.0	677.4	612.1	65.26	10.379			
9,300.0	9,100.4	9,066.8	8,930.3	38.0	32.5	-87.22	1,910.2	92.5	684.1	618.9	65.20	10.493			
9,325.0	9,116.9	9,065.5	8,929.3	38.0	32.5	-86.15	1,910.1	93.5	691.6	626.5	65.13	10.619			
9,350.0	9,132.4	9,061.9	8,926.8	38.1	32.5	-84.80	1,910.0	96.1	699.9	634.8	65.03	10.762			
9,375.0	9,146.9	9,061.9	8,926.8	38.1	32.5	-83.66	1,910.0	96.1	708.8	643.7	65.02	10.901			
9,400.0	9,160.3	9,058.0	8,924.2	38.2	32.5	-82.12	1,909.9	98.9	718.3	653.3	64.96	11.057			
9,425.0	9,172.5	9,054.5	8,921.8	38.2	32.5	-80.53	1,909.8	101.4	728.3	663.4	64.94	11.216			
9,450.0	9,183.7	9,048.4	8,917.5	38.3	32.5	-78.67	1,909.7	105.7	738.8	674.0	64.89	11.387			
9,475.0	9,193.6	9,048.4	8,917.5	38.4	32.5	-77.24	1,909.7	105.7	749.8	684.8	65.00	11.534			
9,500.0	9,202.3	9,042.5	8,913.2	38.4	32.5	-75.32	1,909.6	109.9	761.1	696.0	65.03	11.704			
9,525.0	9,209.7	9,035.0	8,907.9	38.5	32.5	-73.27	1,909.6	115.1	772.7	707.6	65.05	11.878			
9,550.0	9,216.0	9,035.0	8,907.9	38.6	32.5	-71.73	1,909.6	115.1	784.5	719.2	65.29	12.016			
9,575.0	9,220.9	9,028.7	8,903.3	38.6	32.5	-69.77	1,909.6	119.4	796.5	731.0	65.41	12.176			
9,600.0	9,224.5	9,021.4	8,898.0	38.7	32.4	-67.77	1,909.8	124.4	808.6	743.0	65.55	12.336			
9,625.0	9,226.9	9,021.4	8,898.0	38.8	32.4	-66.23	1,909.8	124.4	820.8	754.9	65.89	12.457			
9,650.0	9,227.9	9,012.4	8,891.3	38.9	32.4	-64.22	1,910.1	130.5	833.0	766.9	66.05	12.611			
9,657.3	9,228.0	9,007.9	8,888.0	38.9	32.4	-63.55	1,910.3	133.5	836.5	770.5	66.06	12.663			
9,700.0	9,228.0	8,999.9	8,882.0	39.1	32.4	-63.15	1,910.7	138.8	857.9	791.4	66.55	12.891			
9,800.0	9,228.0	8,980.7	8,867.6	39.7	32.4	-62.22	1,912.4	151.4	912.7	845.0	67.67	13.487			
9,900.0	9,228.0	8,953.6	8,847.0	40.4	32.3	-60.97	1,916.1	168.6	973.3	904.8	68.57	14.194			

CC - Min centre to center distance or convergent point, SF - min separation factor, ES - min ellipse separation

Anticollision Report

Company:	NEW MEXICO	Local Co-ordinate Reference:	Well SILVER BAR 35-36 FED STATE COM 133H
Project:	(SP) EDDY	TVD Reference:	kb @ 3358.0usft
Reference Site:	SILVER BAR	MD Reference:	kb @ 3358.0usft
Site Error:	0.0 usft	North Reference:	Grid
Reference Well:	SILVER BAR 35-36 FED STATE COM 133H	Survey Calculation Method:	Minimum Curvature
Well Error:	0.0 usft	Output errors are at	2.00 sigma
Reference Wellbore	owb	Database:	Compass_17
Reference Design:	PWP0	Offset TVD Reference:	Offset Datum

Offset Design: IRONHORSE 35-36 FED STATE - IRONHORSE 35 FED 172H - OWB - PWP0												Offset Site Error:	0.0 usft		
Survey Program: 0-MWD												Rule Assigned:		Offset Well Error:	0.0 usft
Measured Reference Depth (usft)	Vertical Depth (usft)	Measured Offset Depth (usft)	Vertical Depth (usft)	Semi Reference (usft)	Major Axis Offset (usft)	Highside Toolface (°)	Offset Wellbore Centre (+N/-S (usft) +E/-W (usft))		Distance Between Centres (usft)	Between Ellipses (usft)	Minimum Separation (usft)	Separation Factor	Warning		
6,500.0	6,363.7	6,582.0	6,517.5	28.2	25.8	-0.23	2,018.9	90.0	967.4	921.2	46.19	20.943			
6,600.0	6,460.3	6,672.7	6,606.7	28.7	26.2	-0.29	2,003.3	88.6	925.2	878.3	46.90	19.727			
6,700.0	6,556.9	6,763.3	6,696.0	29.3	26.6	-0.36	1,987.6	87.2	882.9	835.3	47.61	18.546			
6,800.0	6,653.5	6,853.9	6,785.3	29.8	27.0	-0.43	1,971.9	85.7	840.7	792.4	48.32	17.400			
6,851.3	6,703.0	6,900.4	6,831.1	30.1	27.2	-0.47	1,963.9	85.0	819.0	770.3	48.68	16.825			
6,900.0	6,750.2	6,940.6	6,870.6	30.3	27.4	-0.50	1,957.0	84.4	798.9	749.8	49.05	16.286			
7,000.0	6,847.6	7,013.5	6,942.6	30.8	27.7	-0.55	1,945.6	83.3	761.4	711.5	49.88	15.264			
7,100.0	6,945.7	7,088.7	7,017.2	31.3	28.0	-0.60	1,935.9	82.5	729.7	679.0	50.71	14.391			
7,200.0	7,044.5	7,166.0	7,094.1	31.7	28.3	-0.64	1,927.9	81.7	703.8	652.3	51.50	13.665			
7,300.0	7,143.7	7,245.0	7,172.8	32.1	28.6	-0.67	1,921.8	81.2	684.0	631.8	52.28	13.085			
7,400.0	7,243.3	7,325.1	7,252.8	32.5	28.9	-0.70	1,917.9	80.8	670.4	617.4	53.01	12.646			
7,500.0	7,343.2	7,406.0	7,333.7	32.8	29.2	-0.71	1,916.2	80.7	663.0	609.3	53.71	12.345			
7,601.3	7,444.5	7,502.8	7,430.5	33.1	29.5	1.95	1,916.2	80.6	661.2	606.8	54.38	12.157			
7,700.0	7,543.2	7,601.5	7,529.2	33.4	29.7	1.95	1,916.2	80.6	661.2	606.1	55.04	12.013			
7,800.0	7,643.2	7,701.5	7,629.2	33.7	30.0	1.95	1,916.2	80.6	661.2	605.5	55.70	11.870			
7,900.0	7,743.2	7,801.5	7,729.2	33.9	30.3	1.95	1,916.2	80.6	661.2	604.8	56.37	11.730			
8,000.0	7,843.2	7,901.5	7,829.2	34.2	30.6	1.95	1,916.2	80.6	661.2	604.1	57.03	11.592			
8,100.0	7,943.2	8,001.5	7,929.2	34.5	30.9	1.95	1,916.2	80.6	661.2	603.5	57.70	11.458			
8,200.0	8,043.2	8,101.5	8,029.2	34.8	31.2	1.95	1,916.2	80.6	661.2	602.8	58.37	11.327			
8,300.0	8,143.2	8,201.5	8,129.2	35.1	31.5	1.95	1,916.2	80.6	661.2	602.1	59.04	11.198	CC		
8,400.0	8,243.2	8,297.6	8,224.9	35.4	31.8	2.51	1,916.1	87.1	661.4	601.7	59.70	11.078			
8,500.0	8,343.2	8,387.1	8,311.3	35.7	32.1	4.48	1,916.0	110.0	662.9	602.6	60.34	10.985			
8,600.0	8,443.2	8,465.9	8,382.7	36.0	32.3	7.33	1,915.8	143.2	667.5	606.6	60.94	10.954			
8,700.0	8,543.2	8,532.3	8,437.9	36.3	32.4	10.44	1,915.7	179.9	677.6	616.2	61.37	11.041			
8,800.0	8,643.2	8,587.0	8,479.3	36.6	32.6	13.42	1,915.5	215.7	695.0	633.5	61.45	11.309			
8,907.3	8,750.5	8,634.7	8,511.8	36.9	32.6	16.26	1,915.3	250.6	723.2	662.2	61.04	11.848			
8,925.0	8,768.2	8,641.8	8,516.3	37.0	32.7	-72.91	1,915.3	256.1	728.8	667.8	60.92	11.963			
8,950.0	8,793.1	8,650.0	8,521.4	37.0	32.7	-71.47	1,915.2	262.5	736.7	676.1	60.68	12.142			
8,975.0	8,817.9	8,662.1	8,528.8	37.1	32.7	-69.82	1,915.2	272.1	744.9	684.4	60.50	12.311			
9,000.0	8,842.6	8,675.0	8,536.4	37.2	32.7	-68.17	1,915.1	282.5	753.1	692.7	60.32	12.485			
9,025.0	8,867.0	8,682.9	8,540.9	37.2	32.7	-66.82	1,915.1	289.0	761.3	701.3	60.00	12.688			
9,050.0	8,891.1	8,693.3	8,546.7	37.3	32.7	-65.37	1,915.1	297.7	769.5	709.8	59.72	12.885			
9,075.0	8,914.7	8,700.0	8,550.3	37.4	32.8	-64.13	1,915.0	303.3	777.7	718.3	59.34	13.106			
9,100.0	8,938.0	8,714.5	8,557.8	37.5	32.8	-62.60	1,915.0	315.7	785.7	726.6	59.13	13.289			
9,125.0	8,960.7	8,725.0	8,563.1	37.5	32.8	-61.30	1,914.9	324.8	793.7	734.9	58.81	13.495			
9,150.0	8,982.9	8,735.9	8,568.3	37.6	32.8	-60.05	1,914.9	334.4	801.5	743.0	58.50	13.700			
9,175.0	9,004.4	8,750.0	8,574.7	37.7	32.8	-58.75	1,914.8	346.9	809.1	750.8	58.26	13.887			
9,200.0	9,025.2	8,757.5	8,578.0	37.7	32.9	-57.73	1,914.8	353.7	816.4	758.5	57.87	14.108			
9,225.0	9,045.3	8,768.4	8,582.5	37.8	32.9	-56.66	1,914.7	363.6	823.5	765.9	57.55	14.308			
9,250.0	9,064.5	8,775.0	8,585.2	37.8	32.9	-55.77	1,914.7	369.6	830.3	773.2	57.15	14.528			
9,275.0	9,082.9	8,790.3	8,591.0	37.9	32.9	-54.72	1,914.6	383.7	836.8	779.9	56.96	14.692			
9,300.0	9,100.4	8,800.0	8,594.4	38.0	32.9	-53.87	1,914.6	392.8	843.0	786.3	56.65	14.881			
9,325.0	9,116.9	8,812.3	8,598.5	38.0	33.0	-53.04	1,914.5	404.4	848.8	792.4	56.42	15.046			
9,350.0	9,132.4	8,825.0	8,602.5	38.1	33.0	-52.27	1,914.5	416.5	854.3	798.1	56.21	15.199			
9,375.0	9,146.9	8,834.4	8,605.2	38.1	33.0	-51.62	1,914.4	425.5	859.3	803.4	55.96	15.357			
9,400.0	9,160.3	8,850.0	8,609.3	38.2	33.0	-50.94	1,914.4	440.5	864.0	808.2	55.85	15.472			
9,425.0	9,172.5	8,850.0	8,609.3	38.2	33.0	-50.53	1,914.4	440.5	868.3	812.8	55.49	15.647			
9,450.0	9,183.7	8,867.7	8,613.3	38.3	33.1	-49.96	1,914.3	457.7	872.1	816.6	55.47	15.720			
9,475.0	9,193.6	8,875.0	8,614.8	38.4	33.1	-49.57	1,914.2	464.9	875.4	820.1	55.32	15.825			
9,500.0	9,202.3	8,890.0	8,617.5	38.4	33.1	-49.17	1,914.2	479.6	878.3	823.0	55.31	15.880			
9,525.0	9,209.7	8,900.0	8,619.0	38.5	33.2	-48.87	1,914.1	489.5	880.8	825.5	55.27	15.935			

CC - Min centre to center distance or convergent point, SF - min separation factor, ES - min ellipse separation

Anticollision Report

Company:	NEW MEXICO	Local Co-ordinate Reference:	Well SILVER BAR 35-36 FED STATE COM 133H
Project:	(SP) EDDY	TVD Reference:	kb @ 3358.0usft
Reference Site:	SILVER BAR	MD Reference:	kb @ 3358.0usft
Site Error:	0.0 usft	North Reference:	Grid
Reference Well:	SILVER BAR 35-36 FED STATE COM 133H	Survey Calculation Method:	Minimum Curvature
Well Error:	0.0 usft	Output errors are at	2.00 sigma
Reference Wellbore	owb	Database:	Compass_17
Reference Design:	PWP0	Offset TVD Reference:	Offset Datum

Offset Design: IRONHORSE 35-36 FED STATE - IRONHORSE 35 FED 172H - OWB - PWP0													Offset Site Error:	0.0 usft
Survey Program: 0-MWD													Offset Well Error:	0.0 usft
Measured Depth (usft)	Vertical Depth (usft)	Measured Depth (usft)	Vertical Depth (usft)	Semi Reference (usft)	Major Axis Offset (usft)	Highside Toolface (°)	Offset Wellbore Centre		Distance Between Centres (usft)		Minimum Separation (usft)	Separation Factor	Warning	
9,550.0	9,216.0	8,912.3	8,620.6	38.6	33.2	-48.62	1,914.0	501.7	882.8	827.5	55.30	15.963		
9,575.0	9,220.9	8,925.0	8,622.0	38.6	33.3	-48.42	1,914.0	514.4	884.3	828.9	55.37	15.971		
9,600.0	9,224.5	8,934.6	8,622.7	38.7	33.3	-48.30	1,913.9	523.9	885.3	829.9	55.45	15.966		
9,625.0	9,226.9	8,950.0	8,623.6	38.8	33.3	-48.23	1,913.9	539.3	885.9	830.3	55.62	15.929		
9,650.0	9,227.9	8,957.0	8,623.8	38.9	33.4	-48.22	1,913.8	546.3	886.0	830.2	55.76	15.888		
9,657.3	9,228.0	8,960.2	8,623.9	38.9	33.4	-48.23	1,913.8	549.6	885.9	830.1	55.82	15.870		
9,684.9	9,228.0	8,977.2	8,624.0	39.0	33.5	-48.23	1,913.7	566.5	885.8	829.7	56.09	15.793		
9,700.0	9,228.0	8,992.3	8,624.0	39.1	33.5	-48.23	1,913.6	581.7	885.8	829.5	56.26	15.744		
9,800.0	9,228.0	9,092.3	8,624.0	39.7	34.1	-48.23	1,913.1	681.7	885.8	828.2	57.56	15.889		
9,900.0	9,228.0	9,192.3	8,624.0	40.4	35.0	-48.23	1,912.6	781.6	885.7	826.7	59.07	14.994		
10,000.0	9,228.0	9,292.3	8,624.0	41.2	36.0	-48.23	1,912.1	881.6	885.7	824.9	60.78	14.572		
10,100.0	9,228.0	9,392.3	8,624.0	42.3	37.2	-48.23	1,911.6	981.6	885.7	823.0	62.68	14.131		
10,200.0	9,228.0	9,492.3	8,624.0	43.5	38.5	-48.23	1,911.1	1,081.6	885.6	820.9	64.74	13.680		
10,300.0	9,228.0	9,592.3	8,624.0	44.7	39.9	-48.22	1,910.6	1,181.6	885.6	818.7	66.95	13.228		
10,400.0	9,228.0	9,692.3	8,624.0	46.1	41.4	-48.22	1,910.1	1,281.6	885.6	816.3	69.30	12.779		
10,500.0	9,228.0	9,792.3	8,624.0	47.6	43.0	-48.22	1,909.6	1,381.6	885.5	813.8	71.77	12.339		
10,600.0	9,228.0	9,892.3	8,624.0	49.2	44.7	-48.22	1,909.1	1,481.6	885.5	811.2	74.35	11.910		
10,700.0	9,228.0	9,992.3	8,624.0	50.9	46.4	-48.22	1,908.6	1,581.6	885.5	808.5	77.03	11.496		
10,800.0	9,228.0	10,092.3	8,624.0	52.6	48.3	-48.22	1,908.1	1,681.6	885.5	805.7	79.79	11.097		
10,900.0	9,228.0	10,192.3	8,624.0	54.4	50.1	-48.21	1,907.6	1,781.6	885.4	802.8	82.64	10.714		
11,000.0	9,228.0	10,292.3	8,624.0	56.2	52.0	-48.21	1,907.1	1,881.6	885.4	799.8	85.56	10.349		
11,100.0	9,228.0	10,392.3	8,624.0	58.0	54.0	-48.21	1,906.6	1,981.6	885.4	796.8	88.54	10.000		
11,200.0	9,228.0	10,492.3	8,624.0	60.0	56.0	-48.21	1,906.1	2,081.6	885.3	793.8	91.58	9.668		
11,300.0	9,228.0	10,592.3	8,624.0	61.9	58.0	-48.21	1,905.6	2,181.6	885.3	790.7	94.67	9.352		
11,400.0	9,228.0	10,692.3	8,624.0	63.9	60.0	-48.21	1,905.1	2,281.6	885.3	787.5	97.80	9.052		
11,500.0	9,228.0	10,792.3	8,624.0	65.9	62.1	-48.20	1,904.6	2,381.6	885.3	784.3	100.98	8.766		
11,600.0	9,228.0	10,892.3	8,624.0	67.9	64.2	-48.20	1,904.1	2,481.6	885.2	781.0	104.20	8.495		
11,700.0	9,228.0	10,992.3	8,624.0	70.0	66.3	-48.20	1,903.6	2,581.6	885.2	777.7	107.46	8.238		
11,800.0	9,228.0	11,092.3	8,624.0	72.1	68.5	-48.20	1,903.1	2,681.6	885.2	774.4	110.74	7.993		
11,900.0	9,228.0	11,192.3	8,624.0	74.2	70.6	-48.20	1,902.6	2,781.6	885.1	771.1	114.06	7.761		
12,000.0	9,228.0	11,292.3	8,624.0	76.3	72.8	-48.20	1,902.1	2,881.6	885.1	767.7	117.40	7.539		
12,100.0	9,228.0	11,392.3	8,624.0	78.5	75.0	-48.19	1,901.6	2,981.6	885.1	764.3	120.77	7.329		
12,200.0	9,228.0	11,492.3	8,624.0	80.6	77.2	-48.19	1,901.1	3,081.6	885.1	760.9	124.15	7.129		
12,300.0	9,228.0	11,592.3	8,624.0	82.8	79.4	-48.19	1,900.6	3,181.6	885.0	757.5	127.56	6.938		
12,400.0	9,228.0	11,692.3	8,624.0	85.0	81.6	-48.19	1,900.1	3,281.6	885.0	754.0	130.99	6.756		
12,500.0	9,228.0	11,792.3	8,624.0	87.2	83.9	-48.19	1,899.6	3,381.6	885.0	750.5	134.44	6.583		
12,600.0	9,228.0	11,892.3	8,624.0	89.4	86.1	-48.19	1,899.1	3,481.6	884.9	747.0	137.90	6.417		
12,700.0	9,228.0	11,992.3	8,624.0	91.6	88.4	-48.18	1,898.6	3,581.6	884.9	743.5	141.38	6.259		
12,800.0	9,228.0	12,092.3	8,624.0	93.8	90.7	-48.18	1,898.1	3,681.6	884.9	740.0	144.87	6.108		
12,900.0	9,228.0	12,192.3	8,624.0	96.1	92.9	-48.18	1,897.6	3,781.6	884.9	736.5	148.37	5.964		
13,000.0	9,228.0	12,292.3	8,624.0	98.3	95.2	-48.18	1,897.1	3,881.6	884.8	732.9	151.89	5.825		
13,100.0	9,228.0	12,392.3	8,624.0	100.6	97.5	-48.18	1,896.6	3,981.6	884.8	729.4	155.42	5.693		
13,200.0	9,228.0	12,492.3	8,624.0	102.9	99.8	-48.18	1,896.1	4,081.6	884.8	725.8	158.96	5.566		
13,300.0	9,228.0	12,592.3	8,624.0	105.1	102.1	-48.18	1,895.6	4,181.6	884.7	722.2	162.50	5.444		
13,400.0	9,228.0	12,692.3	8,624.0	107.4	104.4	-48.17	1,895.1	4,281.6	884.7	718.7	166.06	5.328		
13,500.0	9,228.0	12,792.3	8,624.0	109.7	106.7	-48.17	1,894.6	4,381.6	884.7	715.1	169.63	5.215		
13,600.0	9,228.0	12,892.3	8,624.0	112.0	109.0	-48.17	1,894.1	4,481.6	884.7	711.5	173.20	5.108		
13,700.0	9,228.0	12,992.3	8,624.0	114.3	111.4	-48.17	1,893.6	4,581.6	884.6	707.8	176.78	5.004		
13,800.0	9,228.0	13,092.3	8,624.0	116.6	113.7	-48.17	1,893.1	4,681.6	884.6	704.2	180.37	4.904		
13,900.0	9,228.0	13,192.3	8,624.0	118.9	116.0	-48.17	1,892.6	4,781.6	884.6	700.6	183.97	4.808		
14,000.0	9,228.0	13,292.3	8,624.0	121.2	118.3	-48.16	1,892.1	4,881.6	884.5	697.0	187.57	4.716		

CC - Min centre to center distance or convergent point, SF - min separation factor, ES - min ellipse separation

Anticollision Report

Company:	NEW MEXICO	Local Co-ordinate Reference:	Well SILVER BAR 35-36 FED STATE COM 133H
Project:	(SP) EDDY	TVD Reference:	kb @ 3358.0usft
Reference Site:	SILVER BAR	MD Reference:	kb @ 3358.0usft
Site Error:	0.0 usft	North Reference:	Grid
Reference Well:	SILVER BAR 35-36 FED STATE COM 133H	Survey Calculation Method:	Minimum Curvature
Well Error:	0.0 usft	Output errors are at	2.00 sigma
Reference Wellbore	owb	Database:	Compass_17
Reference Design:	PWP0	Offset TVD Reference:	Offset Datum

Offset Design: IRONHORSE 35-36 FED STATE - IRONHORSE 35 FED 172H - OWB - PWP0													Offset Site Error:	0.0 usft		
Survey Program: 0-MWD													Rule Assigned:		Offset Well Error:	0.0 usft
Measured Depth (usft)	Vertical Depth (usft)	Measured Depth (usft)	Vertical Depth (usft)	Semi Reference (usft)	Major Axis Offset (usft)	Highside Toolface (°)	Offset Wellbore Centre		Distance Between Centres (usft)		Minimum Separation (usft)	Separation Factor	Warning			
							+N/-S (usft)	+E/-W (usft)	Between Centres (usft)	Between Ellipses (usft)						
14,100.0	9,228.0	13,392.3	8,624.0	123.5	120.7	-48.16	1,891.6	4,981.6	884.5	693.3	191.17	4.627				
14,200.0	9,228.0	13,492.3	8,624.0	125.8	123.0	-48.16	1,891.1	5,081.6	884.5	689.7	194.79	4.541				
14,300.0	9,228.0	13,592.3	8,624.0	128.2	125.4	-48.16	1,890.6	5,181.6	884.5	686.1	198.41	4.458				
14,400.0	9,228.0	13,692.3	8,624.0	130.5	127.7	-48.16	1,890.1	5,281.6	884.4	682.4	202.03	4.378				
14,500.0	9,228.0	13,792.3	8,624.0	132.8	130.1	-48.16	1,889.6	5,381.6	884.4	678.7	205.66	4.300				
14,600.0	9,228.0	13,892.3	8,624.0	135.1	132.4	-48.15	1,889.1	5,481.6	884.4	675.1	209.29	4.226				
14,700.0	9,228.0	13,992.3	8,624.0	137.5	134.8	-48.15	1,888.6	5,581.6	884.3	671.4	212.92	4.153				
14,800.0	9,228.0	14,092.3	8,624.0	139.8	137.1	-48.15	1,888.1	5,681.6	884.3	667.8	216.56	4.083				
14,900.0	9,228.0	14,192.3	8,624.0	142.2	139.5	-48.15	1,887.5	5,781.6	884.3	664.1	220.21	4.016				
15,000.0	9,228.0	14,292.3	8,624.0	144.5	141.8	-48.15	1,887.0	5,881.6	884.3	660.4	223.86	3.950				
15,100.0	9,228.0	14,392.3	8,624.0	146.8	144.2	-48.15	1,886.5	5,981.6	884.2	656.7	227.51	3.887				
15,200.0	9,228.0	14,492.3	8,624.0	149.2	146.6	-48.14	1,886.0	6,081.6	884.2	653.0	231.16	3.825				
15,300.0	9,228.0	14,592.3	8,624.0	151.6	148.9	-48.14	1,885.5	6,181.6	884.2	649.4	234.82	3.765				
15,400.0	9,228.0	14,692.3	8,624.0	153.9	151.3	-48.14	1,885.0	6,281.6	884.1	645.7	238.48	3.707				
15,500.0	9,228.0	14,792.3	8,624.0	156.3	153.7	-48.14	1,884.5	6,381.6	884.1	642.0	242.14	3.651				
15,600.0	9,228.0	14,892.3	8,624.0	158.6	156.0	-48.14	1,884.0	6,481.6	884.1	638.3	245.81	3.597				
15,700.0	9,228.0	14,992.3	8,624.0	161.0	158.4	-48.14	1,883.5	6,581.6	884.1	634.6	249.48	3.544				
15,800.0	9,228.0	15,092.3	8,624.0	163.3	160.8	-48.13	1,883.0	6,681.6	884.0	630.9	253.15	3.492				
15,900.0	9,228.0	15,192.3	8,624.0	165.7	163.2	-48.13	1,882.5	6,781.6	884.0	627.2	256.82	3.442				
16,000.0	9,228.0	15,292.3	8,624.0	168.1	165.5	-48.13	1,882.0	6,881.6	884.0	623.5	260.50	3.393				
16,100.0	9,228.0	15,392.3	8,624.0	170.4	167.9	-48.13	1,881.5	6,981.6	883.9	619.8	264.17	3.346				
16,200.0	9,228.0	15,492.3	8,624.0	172.8	170.3	-48.13	1,881.0	7,081.6	883.9	616.1	267.85	3.300				
16,300.0	9,228.0	15,592.3	8,624.0	175.2	172.7	-48.13	1,880.5	7,181.6	883.9	612.4	271.53	3.255				
16,400.0	9,228.0	15,692.3	8,624.0	177.5	175.1	-48.12	1,880.0	7,281.6	883.9	608.6	275.22	3.212				
16,500.0	9,228.0	15,792.3	8,624.0	179.9	177.4	-48.12	1,879.5	7,381.6	883.8	604.9	278.90	3.169				
16,600.0	9,228.0	15,892.3	8,624.0	182.3	179.8	-48.12	1,879.0	7,481.6	883.8	601.2	282.59	3.128				
16,700.0	9,228.0	15,992.3	8,624.0	184.7	182.2	-48.12	1,878.5	7,581.6	883.8	597.5	286.28	3.087				
16,800.0	9,228.0	16,092.3	8,624.0	187.0	184.6	-48.12	1,878.0	7,681.6	883.7	593.8	289.97	3.048				
16,900.0	9,228.0	16,192.3	8,624.0	189.4	187.0	-48.12	1,877.5	7,781.6	883.7	590.1	293.66	3.009				
17,000.0	9,228.0	16,292.3	8,624.0	191.8	189.4	-48.11	1,877.0	7,881.6	883.7	586.3	297.35	2.972				
17,100.0	9,228.0	16,392.3	8,624.0	194.2	191.8	-48.11	1,876.5	7,981.6	883.7	582.6	301.04	2.935				
17,200.0	9,228.0	16,492.3	8,624.0	196.6	194.1	-48.11	1,876.0	8,081.6	883.6	578.9	304.74	2.900				
17,300.0	9,228.0	16,592.3	8,624.0	198.9	196.5	-48.11	1,875.5	8,181.6	883.6	575.2	308.44	2.865				
17,400.0	9,228.0	16,692.3	8,624.0	201.3	198.9	-48.11	1,875.0	8,281.6	883.6	571.4	312.13	2.831				
17,500.0	9,228.0	16,792.3	8,624.0	203.7	201.3	-48.11	1,874.5	8,381.6	883.5	567.7	315.83	2.798				
17,600.0	9,228.0	16,892.3	8,624.0	206.1	203.7	-48.10	1,874.0	8,481.6	883.5	564.0	319.53	2.765				
17,700.0	9,228.0	16,992.3	8,624.0	208.5	206.1	-48.10	1,873.5	8,581.6	883.5	560.3	323.23	2.733				
17,800.0	9,228.0	17,092.3	8,624.0	210.9	208.5	-48.10	1,873.0	8,681.6	883.5	556.5	326.94	2.702				
17,900.0	9,228.0	17,192.3	8,624.0	213.2	210.9	-48.10	1,872.5	8,781.5	883.4	552.8	330.64	2.672				
18,000.0	9,228.0	17,292.3	8,624.0	215.6	213.3	-48.10	1,872.0	8,881.5	883.4	549.1	334.34	2.642				
18,100.0	9,228.0	17,392.3	8,624.0	218.0	215.7	-48.10	1,871.5	8,981.5	883.4	545.3	338.05	2.613				
18,200.0	9,228.0	17,492.3	8,624.0	220.4	218.1	-48.09	1,871.0	9,081.5	883.3	541.6	341.76	2.585				
18,300.0	9,228.0	17,592.3	8,624.0	222.8	220.5	-48.09	1,870.5	9,181.5	883.3	537.9	345.46	2.557				
18,400.0	9,228.0	17,692.3	8,624.0	225.2	222.9	-48.09	1,870.0	9,281.5	883.3	534.1	349.17	2.530				
18,500.0	9,228.0	17,792.3	8,624.0	227.6	225.3	-48.09	1,869.5	9,381.5	883.3	530.4	352.88	2.503				
18,600.0	9,228.0	17,892.3	8,624.0	230.0	227.7	-48.09	1,869.0	9,481.5	883.2	526.6	356.59	2.477				
18,700.0	9,228.0	17,992.3	8,624.0	232.4	230.1	-48.09	1,868.5	9,581.5	883.2	522.9	360.30	2.451				
18,800.0	9,228.0	18,092.3	8,624.0	234.7	232.5	-48.08	1,868.0	9,681.5	883.2	519.2	364.01	2.426				
18,900.0	9,228.0	18,192.3	8,624.0	237.1	234.9	-48.08	1,867.5	9,781.5	883.1	515.4	367.72	2.402				
19,000.0	9,228.0	18,292.3	8,624.0	239.5	237.3	-48.08	1,867.0	9,881.5	883.1	511.7	371.43	2.378				
19,100.0	9,228.0	18,392.3	8,624.0	241.9	239.7	-48.08	1,866.5	9,981.5	883.1	507.9	375.14	2.354				

CC - Min centre to center distance or convergent point, SF - min separation factor, ES - min ellipse separation

Anticollision Report

Company:	NEW MEXICO	Local Co-ordinate Reference:	Well SILVER BAR 35-36 FED STATE COM 133H
Project:	(SP) EDDY	TVD Reference:	kb @ 3358.0usft
Reference Site:	SILVER BAR	MD Reference:	kb @ 3358.0usft
Site Error:	0.0 usft	North Reference:	Grid
Reference Well:	SILVER BAR 35-36 FED STATE COM 133H	Survey Calculation Method:	Minimum Curvature
Well Error:	0.0 usft	Output errors are at	2.00 sigma
Reference Wellbore	owb	Database:	Compass_17
Reference Design:	PWP0	Offset TVD Reference:	Offset Datum

Offset Design: IRONHORSE 35-36 FED STATE - IRONHORSE 35 FED 172H - OWB - PWP0													Offset Site Error:	0.0 usft
Survey Program: 0-MWD													Offset Well Error:	0.0 usft
Measured Reference Depth (usft)	Vertical Depth (usft)	Offset		Semi Major Axis		Highside Toolface (°)	Offset Wellbore Centre		Rule Assigned: Distance		Minimum Separation (usft)	Separation Factor	Warning	
		Measured Depth (usft)	Vertical Depth (usft)	Reference (usft)	Offset (usft)		+N/-S (usft)	+E/-W (usft)	Between Centres (usft)	Between Ellipses (usft)				
19,200.0	9,228.0	18,492.3	8,624.0	244.3	242.1	-48.08	1,866.0	10,081.5	883.1	504.2	378.86	2.331		
19,300.0	9,228.0	18,592.3	8,624.0	246.7	244.5	-48.08	1,865.5	10,181.5	883.0	500.5	382.57	2.308		
19,400.0	9,228.0	18,692.3	8,624.0	249.1	246.9	-48.07	1,865.0	10,281.5	883.0	496.7	386.28	2.286		
19,500.0	9,228.0	18,792.3	8,624.0	251.5	249.3	-48.07	1,864.5	10,381.5	883.0	493.0	390.00	2.264		
19,600.0	9,228.0	18,892.3	8,624.0	253.9	251.7	-48.07	1,864.0	10,481.5	882.9	489.2	393.71	2.243		
19,700.0	9,228.0	18,992.3	8,624.0	256.3	254.1	-48.07	1,863.5	10,581.5	882.9	485.5	397.43	2.222		
19,800.0	9,228.0	19,092.3	8,624.0	258.7	256.5	-48.07	1,863.0	10,681.5	882.9	481.7	401.15	2.201		
19,900.0	9,228.0	19,192.3	8,624.0	261.1	258.9	-48.07	1,862.5	10,781.5	882.9	478.0	404.86	2.181		
19,943.6	9,228.0	19,235.6	8,624.0	262.1	259.9	-48.06	1,862.2	10,824.8	882.8	476.4	406.48	2.172		
19,947.8	9,228.0	19,235.6	8,624.0	262.2	259.9	-48.06	1,862.2	10,824.8	882.9	476.3	406.57	2.171	ES, SF	

CC - Min centre to center distance or convergent point, SF - min separation factor, ES - min ellipse separation

Anticollision Report

Company:	NEW MEXICO	Local Co-ordinate Reference:	Well SILVER BAR 35-36 FED STATE COM 133H
Project:	(SP) EDDY	TVD Reference:	kb @ 3358.0usft
Reference Site:	SILVER BAR	MD Reference:	kb @ 3358.0usft
Site Error:	0.0 usft	North Reference:	Grid
Reference Well:	SILVER BAR 35-36 FED STATE COM 133H	Survey Calculation Method:	Minimum Curvature
Well Error:	0.0 usft	Output errors are at	2.00 sigma
Reference Wellbore	owb	Database:	Compass_17
Reference Design:	PWP0	Offset TVD Reference:	Offset Datum

Offset Design: IRONHORSE 35-36 FED STATE - IRONHORSE 35 FED 201H - OWB - PWP0													Offset Site Error:	0.0 usft
Survey Program: 0-MWD											Rule Assigned:		Offset Well Error:	0.0 usft
Measured Reference Depth (usft)	Vertical Reference Depth (usft)	Measured Offset Depth (usft)	Vertical Offset Depth (usft)	Semi Reference (usft)	Major Axis Offset (usft)	Highside Toolface (°)	Offset Wellbore Centre		Distance Between Centres (usft)	Distance Between Ellipses (usft)	Minimum Separation (usft)	Separation Factor	Warning	
7,400.0	7,243.3	7,287.1	7,229.3	32.5	26.9	3.66	2,242.1	167.7	999.8	947.2	52.60	19.009		
7,500.0	7,343.2	7,387.0	7,329.2	32.8	27.2	3.67	2,242.1	167.7	994.5	941.2	53.29	18.663		
7,601.3	7,444.5	7,488.2	7,430.5	33.1	27.6	6.33	2,242.1	167.7	992.7	938.8	53.98	18.390		
7,700.0	7,543.2	7,586.9	7,529.2	33.4	27.9	6.33	2,242.1	167.7	992.7	938.1	54.65	18.164		
7,800.0	7,643.2	7,686.9	7,629.2	33.7	28.2	6.33	2,242.1	167.7	992.7	937.4	55.34	17.941		
7,900.0	7,743.2	7,786.9	7,729.2	33.9	28.5	6.33	2,242.1	167.7	992.7	936.7	56.02	17.722		
8,000.0	7,843.2	7,886.9	7,829.2	34.2	28.9	6.33	2,242.1	167.7	992.7	936.0	56.70	17.509		
8,100.0	7,943.2	7,986.9	7,929.2	34.5	29.2	6.33	2,242.1	167.7	992.7	935.4	57.38	17.300		
8,200.0	8,043.2	8,086.9	8,029.2	34.8	29.5	6.33	2,242.1	167.7	992.7	934.7	58.07	17.096		
8,300.0	8,143.2	8,186.9	8,129.2	35.1	29.9	6.33	2,242.1	167.7	992.7	934.0	58.75	16.897		
8,400.0	8,243.2	8,286.9	8,229.2	35.4	30.2	6.33	2,242.1	167.7	992.7	933.3	59.44	16.702		
8,500.0	8,343.2	8,386.9	8,329.2	35.7	30.5	6.33	2,242.1	167.7	992.7	932.6	60.13	16.511		
8,600.0	8,443.2	8,486.9	8,429.2	36.0	30.9	6.33	2,242.1	167.7	992.7	931.9	60.81	16.324		
8,700.0	8,543.2	8,586.9	8,529.2	36.3	31.2	6.33	2,242.1	167.7	992.7	931.2	61.50	16.142		
8,800.0	8,643.2	8,686.9	8,629.2	36.6	31.5	6.33	2,242.1	167.7	992.7	930.6	62.19	15.963		
8,907.3	8,750.5	8,794.3	8,736.5	36.9	31.9	6.33	2,242.1	167.7	992.7	929.8	62.93	15.775		
8,925.0	8,768.2	8,811.9	8,754.2	37.0	31.9	-83.96	2,242.1	167.7	992.7	929.7	63.05	15.745		
8,950.0	8,793.1	8,836.9	8,779.1	37.0	32.0	-84.07	2,242.1	167.7	992.5	929.3	63.22	15.701		
8,975.0	8,817.9	8,861.7	8,803.9	37.1	32.1	-84.27	2,242.1	167.7	992.3	928.9	63.38	15.655		
9,000.0	8,842.6	8,886.4	8,828.6	37.2	32.2	-84.55	2,242.1	167.7	991.8	928.3	63.54	15.609		
9,025.0	8,867.0	8,909.2	8,851.5	37.2	32.3	-84.90	2,242.1	167.8	991.3	927.6	63.70	15.562		
9,050.0	8,891.1	8,929.8	8,872.0	37.3	32.3	-85.23	2,242.1	168.5	990.8	927.0	63.86	15.516		
9,075.0	8,914.7	8,950.0	8,892.2	37.4	32.4	-85.57	2,242.1	170.2	990.3	926.3	64.01	15.471		
9,100.0	8,938.0	8,971.4	8,913.4	37.5	32.5	-85.94	2,242.0	172.8	989.8	925.7	64.17	15.426		
9,125.0	8,960.7	8,992.5	8,934.2	37.5	32.5	-86.31	2,242.0	176.4	989.4	925.1	64.32	15.382		
9,150.0	8,982.9	9,013.8	8,955.0	37.6	32.6	-86.68	2,242.0	180.9	989.0	924.5	64.48	15.338		
9,175.0	9,004.4	9,035.3	8,975.8	37.7	32.7	-87.07	2,242.0	186.4	988.6	923.9	64.64	15.295		
9,200.0	9,025.2	9,057.1	8,996.6	37.7	32.7	-87.46	2,242.0	192.9	988.2	923.4	64.80	15.251		
9,225.0	9,045.3	9,079.1	9,017.3	37.8	32.8	-87.86	2,241.9	200.4	987.9	923.0	64.96	15.208		
9,250.0	9,064.5	9,101.4	9,037.8	37.8	32.9	-88.27	2,241.9	209.0	987.7	922.6	65.13	15.166		
9,275.0	9,082.9	9,124.0	9,058.2	37.9	33.0	-88.69	2,241.8	218.7	987.5	922.2	65.30	15.123		
9,300.0	9,100.4	9,146.9	9,078.4	38.0	33.0	-89.10	2,241.8	229.5	987.3	921.8	65.47	15.081		
9,325.0	9,116.9	9,170.1	9,098.3	38.0	33.1	-89.53	2,241.7	241.4	987.2	921.6	65.65	15.038		
9,350.0	9,132.4	9,193.6	9,117.9	38.1	33.1	-89.95	2,241.7	254.4	987.2	921.4	65.83	14.996		
9,353.1	9,134.3	9,196.6	9,120.3	38.1	33.2	-90.00	2,241.7	256.1	987.2	921.3	65.85	14.991	CC	
9,375.0	9,146.9	9,217.5	9,137.2	38.1	33.2	-90.38	2,241.6	268.7	987.2	921.2	66.02	14.953		
9,400.0	9,160.3	9,241.8	9,155.9	38.2	33.3	-90.81	2,241.5	284.1	987.3	921.1	66.21	14.911		
9,425.0	9,172.5	9,266.5	9,174.2	38.2	33.3	-91.24	2,241.4	300.7	987.4	921.0	66.41	14.868		
9,450.0	9,183.7	9,291.7	9,191.8	38.3	33.4	-91.67	2,241.4	318.6	987.6	921.0	66.62	14.825		
9,475.0	9,193.6	9,317.3	9,208.8	38.4	33.5	-92.11	2,241.3	337.7	987.9	921.1	66.83	14.782		
9,500.0	9,202.3	9,343.3	9,225.1	38.4	33.5	-92.54	2,241.2	358.1	988.2	921.2	67.05	14.739		
9,525.0	9,209.7	9,369.9	9,240.4	38.5	33.6	-92.96	2,241.1	379.8	988.6	921.4	67.28	14.695		
9,550.0	9,216.0	9,396.9	9,254.8	38.6	33.7	-93.39	2,241.0	402.7	989.1	921.6	67.51	14.650		
9,575.0	9,220.9	9,424.6	9,268.1	38.6	33.7	-93.81	2,240.9	426.9	989.6	921.8	67.76	14.605		
9,600.0	9,224.5	9,452.7	9,280.3	38.7	33.8	-94.23	2,240.7	452.3	990.1	922.1	68.01	14.559		
9,625.0	9,226.9	9,481.5	9,291.1	38.8	33.9	-94.63	2,240.6	478.9	990.7	922.4	68.27	14.511		
9,650.0	9,227.9	9,510.8	9,300.5	38.9	34.0	-95.03	2,240.5	506.7	991.3	922.8	68.55	14.462		
9,657.3	9,228.0	9,519.5	9,302.9	38.9	34.1	-95.15	2,240.4	515.1	991.5	922.9	68.63	14.447		
9,700.0	9,228.0	9,571.8	9,314.4	39.1	34.3	-95.81	2,240.2	566.1	992.4	923.2	69.16	14.350		
9,800.0	9,228.0	9,689.1	9,321.0	39.7	35.1	-96.19	2,239.7	682.9	992.9	922.2	70.73	14.039		
9,900.0	9,228.0	9,789.1	9,321.0	40.4	35.9	-96.19	2,239.2	782.9	992.9	920.4	72.56	13.685		

CC - Min centre to center distance or convergent point, SF - min separation factor, ES - min ellipse separation

Anticollision Report

Company:	NEW MEXICO	Local Co-ordinate Reference:	Well SILVER BAR 35-36 FED STATE COM 133H
Project:	(SP) EDDY	TVD Reference:	kb @ 3358.0usft
Reference Site:	SILVER BAR	MD Reference:	kb @ 3358.0usft
Site Error:	0.0 usft	North Reference:	Grid
Reference Well:	SILVER BAR 35-36 FED STATE COM 133H	Survey Calculation Method:	Minimum Curvature
Well Error:	0.0 usft	Output errors are at	2.00 sigma
Reference Wellbore	owb	Database:	Compass_17
Reference Design:	PWP0	Offset TVD Reference:	Offset Datum

Offset Design: IRONHORSE 35-36 FED STATE - IRONHORSE 35 FED 201H - OWB - PWP0													Offset Site Error:	0.0 usft			
Survey Program: 0-MWD		Reference		Offset		Semi Major Axis		Highside Toolface (°)	Offset Wellbore Centre		Rule Assigned: Distance		Minimum Separation (usft)	Separation Factor	Warning	Offset Well Error:	0.0 usft
Measured Depth (usft)	Vertical Depth (usft)	Measured Depth (usft)	Vertical Depth (usft)	Reference (usft)	Offset (usft)	Reference (usft)	Offset (usft)		+N/-S (usft)	+E/-W (usft)	Between Centres (usft)	Between Ellipses (usft)					
10,000.0	9,228.0	9,889.1	9,321.0	41.2	36.8	-96.19	2,238.7	882.9	992.9	918.3	74.65	13.301					
10,100.0	9,228.0	9,989.1	9,321.0	42.3	37.9	-96.19	2,238.3	982.9	992.9	915.9	76.99	12.897					
10,200.0	9,228.0	10,089.1	9,321.0	43.5	39.1	-96.19	2,237.8	1,082.9	992.9	913.4	79.55	12.482					
10,300.0	9,228.0	10,189.1	9,321.0	44.7	40.5	-96.19	2,237.3	1,182.9	992.9	910.6	82.32	12.062					
10,400.0	9,228.0	10,289.1	9,321.0	46.1	41.9	-96.19	2,236.9	1,282.9	992.9	907.7	85.26	11.645					
10,500.0	9,228.0	10,389.1	9,321.0	47.6	43.4	-96.19	2,236.4	1,382.9	992.9	904.5	88.37	11.235					
10,600.0	9,228.0	10,489.1	9,321.0	49.2	45.0	-96.19	2,235.9	1,482.9	992.9	901.3	91.63	10.836					
10,700.0	9,228.0	10,589.1	9,321.0	50.9	46.7	-96.19	2,235.5	1,582.9	992.9	897.9	95.02	10.449					
10,800.0	9,228.0	10,689.1	9,321.0	52.6	48.4	-96.19	2,235.0	1,682.9	992.9	894.4	98.54	10.077					
10,900.0	9,228.0	10,789.1	9,321.0	54.4	50.2	-96.19	2,234.5	1,782.9	992.9	890.7	102.15	9.720					
11,000.0	9,228.0	10,889.1	9,321.0	56.2	52.0	-96.19	2,234.0	1,882.9	992.9	887.0	105.87	9.379					
11,100.0	9,228.0	10,989.1	9,321.0	58.0	53.9	-96.19	2,233.6	1,982.9	992.9	883.2	109.66	9.054					
11,200.0	9,228.0	11,089.1	9,321.0	60.0	55.8	-96.19	2,233.1	2,082.9	992.9	879.3	113.54	8.745					
11,300.0	9,228.0	11,189.1	9,321.0	61.9	57.8	-96.19	2,232.6	2,182.9	992.9	875.4	117.49	8.451					
11,400.0	9,228.0	11,289.1	9,321.0	63.9	59.8	-96.19	2,232.2	2,282.9	992.9	871.4	121.50	8.172					
11,500.0	9,228.0	11,389.1	9,321.0	65.9	61.8	-96.19	2,231.7	2,382.9	992.9	867.3	125.56	7.907					
11,600.0	9,228.0	11,489.1	9,321.0	67.9	63.9	-96.19	2,231.2	2,482.9	992.9	863.2	129.68	7.656					
11,700.0	9,228.0	11,589.1	9,321.0	70.0	66.0	-96.19	2,230.8	2,582.9	992.9	859.0	133.84	7.418					
11,800.0	9,228.0	11,689.1	9,321.0	72.1	68.1	-96.19	2,230.3	2,682.9	992.9	854.8	138.05	7.192					
11,900.0	9,228.0	11,789.1	9,321.0	74.2	70.2	-96.19	2,229.8	2,782.9	992.9	850.6	142.29	6.978					
12,000.0	9,228.0	11,889.1	9,321.0	76.3	72.3	-96.19	2,229.4	2,882.9	992.9	846.3	146.57	6.774					
12,100.0	9,228.0	11,989.1	9,321.0	78.5	74.5	-96.19	2,228.9	2,982.9	992.9	842.0	150.89	6.580					
12,200.0	9,228.0	12,089.1	9,321.0	80.6	76.7	-96.19	2,228.4	3,082.9	992.8	837.6	155.23	6.396					
12,300.0	9,228.0	12,189.1	9,321.0	82.8	78.9	-96.19	2,228.0	3,182.9	992.8	833.2	159.60	6.221					
12,400.0	9,228.0	12,289.1	9,321.0	85.0	81.1	-96.19	2,227.5	3,282.9	992.8	828.8	163.99	6.054					
12,500.0	9,228.0	12,389.1	9,321.0	87.2	83.3	-96.19	2,227.0	3,382.9	992.8	824.4	168.41	5.895					
12,600.0	9,228.0	12,489.1	9,321.0	89.4	85.5	-96.19	2,226.6	3,482.9	992.8	820.0	172.85	5.744					
12,700.0	9,228.0	12,589.1	9,321.0	91.6	87.8	-96.19	2,226.1	3,582.9	992.8	815.5	177.31	5.599					
12,800.0	9,228.0	12,689.1	9,321.0	93.8	90.0	-96.19	2,225.6	3,682.9	992.8	811.0	181.79	5.462					
12,900.0	9,228.0	12,789.1	9,321.0	96.1	92.3	-96.19	2,225.2	3,782.9	992.8	806.5	186.28	5.330					
13,000.0	9,228.0	12,889.1	9,321.0	98.3	94.5	-96.19	2,224.7	3,882.9	992.8	802.0	190.79	5.204					
13,100.0	9,228.0	12,989.1	9,321.0	100.6	96.8	-96.19	2,224.2	3,982.9	992.8	797.5	195.31	5.083					
13,200.0	9,228.0	13,089.1	9,321.0	102.9	99.1	-96.19	2,223.8	4,082.9	992.8	793.0	199.85	4.968					
13,300.0	9,228.0	13,189.1	9,321.0	105.1	101.4	-96.19	2,223.3	4,182.9	992.8	788.4	204.40	4.857					
13,400.0	9,228.0	13,289.1	9,321.0	107.4	103.6	-96.19	2,222.8	4,282.9	992.8	783.8	208.96	4.751					
13,500.0	9,228.0	13,389.1	9,321.0	109.7	105.9	-96.19	2,222.4	4,382.9	992.8	779.3	213.54	4.649					
13,600.0	9,228.0	13,489.1	9,321.0	112.0	108.2	-96.19	2,221.9	4,482.9	992.8	774.7	218.12	4.552					
13,700.0	9,228.0	13,589.1	9,321.0	114.3	110.6	-96.19	2,221.4	4,582.9	992.8	770.1	222.72	4.458					
13,800.0	9,228.0	13,689.1	9,321.0	116.6	112.9	-96.19	2,221.0	4,682.9	992.8	765.5	227.32	4.367					
13,900.0	9,228.0	13,789.1	9,321.0	118.9	115.2	-96.19	2,220.5	4,782.9	992.8	760.8	231.93	4.280					
14,000.0	9,228.0	13,889.1	9,321.0	121.2	117.5	-96.19	2,220.0	4,882.9	992.8	756.2	236.55	4.197					
14,100.0	9,228.0	13,989.1	9,321.0	123.5	119.8	-96.19	2,219.6	4,982.9	992.8	751.6	241.18	4.116					
14,200.0	9,228.0	14,089.1	9,321.0	125.8	122.2	-96.19	2,219.1	5,082.9	992.8	746.9	245.81	4.039					
14,300.0	9,228.0	14,189.1	9,321.0	128.2	124.5	-96.19	2,218.6	5,182.9	992.8	742.3	250.46	3.964					
14,400.0	9,228.0	14,289.1	9,321.0	130.5	126.8	-96.19	2,218.2	5,282.9	992.8	737.7	255.10	3.892					
14,500.0	9,228.0	14,389.1	9,321.0	132.8	129.2	-96.19	2,217.7	5,382.9	992.8	733.0	259.76	3.822					
14,600.0	9,228.0	14,489.1	9,321.0	135.1	131.5	-96.19	2,217.2	5,482.9	992.7	728.3	264.42	3.754					
14,700.0	9,228.0	14,589.1	9,321.0	137.5	133.8	-96.19	2,216.7	5,582.9	992.7	723.7	269.09	3.689					
14,800.0	9,228.0	14,689.1	9,321.0	139.8	136.2	-96.19	2,216.3	5,682.9	992.7	719.0	273.76	3.626					
14,900.0	9,228.0	14,789.1	9,321.0	142.2	138.5	-96.19	2,215.8	5,782.9	992.7	714.3	278.43	3.565					
15,000.0	9,228.0	14,889.1	9,321.0	144.5	140.9	-96.19	2,215.3	5,882.9	992.7	709.6	283.11	3.506					

CC - Min centre to center distance or convergent point, SF - min separation factor, ES - min ellipse separation

Anticollision Report

Company: NEW MEXICO Local Co-ordinate Reference: Well SILVER BAR 35-36 FED STATE COM 133H
Project: (SP) EDDY TVD Reference: kb @ 3358.0usft
Reference Site: SILVER BAR MD Reference: kb @ 3358.0usft
Site Error: 0.0 usft North Reference: Grid
Reference Well: SILVER BAR 35-36 FED STATE COM 133H Survey Calculation Method: Minimum Curvature
Well Error: 0.0 usft Output errors are at 2.00 sigma
Reference Wellbore: owb Database: Compass_17
Reference Design: PWP0 Offset TVD Reference: Offset Datum

Offset Design: IRONHORSE 35-36 FED STATE - IRONHORSE 35 FED 201H - OWB - PWP0
Survey Program: 0-MWD
Reference Vertical Measured Vertical Offset Vertical Reference Reference Offset Semi Major Axis Highside Offset Wellbore Centre Distance Between Between Minimum Separation Warning
Depth Depth Depth Depth (usft) (usft) (usft) (usft) (usft) (usft) (usft) (+N/-S (usft) +E/-W (usft) Centres (usft) Ellipses (usft) Separation (usft) Factor

CC - Min centre to center distance or convergent point, SF - min separation factor, ES - min ellipse separation

Anticollision Report

Company:	NEW MEXICO	Local Co-ordinate Reference:	Well SILVER BAR 35-36 FED STATE COM 133H
Project:	(SP) EDDY	TVD Reference:	kb @ 3358.0usft
Reference Site:	SILVER BAR	MD Reference:	kb @ 3358.0usft
Site Error:	0.0 usft	North Reference:	Grid
Reference Well:	SILVER BAR 35-36 FED STATE COM 133H	Survey Calculation Method:	Minimum Curvature
Well Error:	0.0 usft	Output errors are at	2.00 sigma
Reference Wellbore	owb	Database:	Compass_17
Reference Design:	PWP0	Offset TVD Reference:	Offset Datum

Anticollision Report

Company:	NEW MEXICO	Local Co-ordinate Reference:	Well SILVER BAR 35-36 FED STATE COM 133H
Project:	(SP) EDDY	TVD Reference:	kb @ 3358.0usft
Reference Site:	SILVER BAR	MD Reference:	kb @ 3358.0usft
Site Error:	0.0 usft	North Reference:	Grid
Reference Well:	SILVER BAR 35-36 FED STATE COM 133H	Survey Calculation Method:	Minimum Curvature
Well Error:	0.0 usft	Output errors are at	2.00 sigma
Reference Wellbore	owb	Database:	Compass_17
Reference Design:	PWP0	Offset TVD Reference:	Offset Datum

Offset Design: IRONHORSE 35-36 FED STATE - Parkway ST 36 #1 - AWP - INC ONLY													Offset Site Error:	0.0 usft
Survey Program:	355-INC-ONLY											Offset Well Error:	0.0 usft	
Reference	Offset		Semi Major Axis		Highside Toolface (°)	Offset Wellbore Centre		Rule Assigned:		Minimum Separation (usft)	Separation Factor	Warning		
Measured Depth (usft)	Vertical Depth (usft)	Measured Depth (usft)	Vertical Depth (usft)	Reference (usft)		Offset (usft)	+N/-S (usft)	+E/-W (usft)	Between Centres (usft)				Between Ellipses (usft)	
16,600.0	9,228.0	9,238.0	9,234.2	182.3	227.9	-90.69	2,207.1	7,615.9	995.7	589.0	406.72	2.448		
16,700.0	9,228.0	9,238.0	9,234.2	184.7	227.9	-90.69	2,207.1	7,615.9	987.3	575.7	411.65	2.398		
16,733.0	9,228.0	9,238.0	9,234.2	185.4	227.9	-90.69	2,207.1	7,615.9	986.8	573.9	412.90	2.390	CC, ES	
16,800.0	9,228.0	9,238.0	9,234.2	187.0	227.9	-90.69	2,207.1	7,615.9	989.0	574.2	414.82	2.384	SF	

CC - Min centre to center distance or convergent point, SF - min separation factor, ES - min ellipse separation

Anticollision Report

Company:	NEW MEXICO	Local Co-ordinate Reference:	Well SILVER BAR 35-36 FED STATE COM 133H
Project:	(SP) EDDY	TVD Reference:	kb @ 3358.0usft
Reference Site:	SILVER BAR	MD Reference:	kb @ 3358.0usft
Site Error:	0.0 usft	North Reference:	Grid
Reference Well:	SILVER BAR 35-36 FED STATE COM 133H	Survey Calculation Method:	Minimum Curvature
Well Error:	0.0 usft	Output errors are at	2.00 sigma
Reference Wellbore	owb	Database:	Compass_17
Reference Design:	PWP0	Offset TVD Reference:	Offset Datum

Offset Design: IRONHORSE 35-36 FED STATE - xxIRONHORSE 35-36 FED STATE COM 174H - OWB - PWP0														Offset Site Error:	0.0 usft
Survey Program: 0-MWD												Rule Assigned:		Offset Well Error:	0.0 usft
Measured Depth (usft)	Vertical Depth (usft)	Measured Depth (usft)	Vertical Depth (usft)	Reference (usft)	Offset (usft)	Semi Major Axis (usft)	Minor Axis (usft)	Highside Toolface (°)	Offset Wellbore Centre +N/-S (usft)	+E/-W (usft)	Distance Between Centres (usft)	Distance Between Ellipses (usft)	Minimum Separation (usft)	Separation Factor	Warning
6,500.0	6,363.7	6,574.2	6,509.8	28.2	25.8	-5.73		-2.033.0	5.1		981.0	934.6	46.40	21.139	
6,600.0	6,460.3	6,664.9	6,599.1	28.7	26.2	-6.15		-2,017.6	1.9		939.3	892.2	47.13	19.928	
6,700.0	6,556.9	6,755.6	6,688.4	29.3	26.6	-6.61		-2,002.2	-1.3		897.7	849.9	47.87	18.754	
6,800.0	6,653.5	6,846.3	6,777.7	29.8	27.0	-7.12		-1,986.7	-4.5		856.2	807.6	48.61	17.614	
6,851.3	6,703.0	6,892.8	6,823.6	30.1	27.2	-7.40		-1,978.8	-6.2		834.9	785.9	48.99	17.042	
6,900.0	6,750.2	6,937.2	6,867.2	30.3	27.4	-7.61		-1,971.3	-7.7		815.1	765.7	49.35	16.515	
7,000.0	6,847.6	7,026.7	6,955.4	30.8	27.8	-8.06		-1,956.1	-10.9		776.8	726.7	50.12	15.499	
7,100.0	6,945.7	7,100.0	7,027.8	31.3	28.1	-8.39		-1,944.8	-13.3		743.3	692.3	51.00	14.574	
7,200.0	7,044.5	7,178.7	7,105.8	31.7	28.4	-8.71		-1,934.7	-15.4		715.5	663.7	51.84	13.802	
7,300.0	7,143.7	7,257.7	7,184.3	32.1	28.7	-8.97		-1,926.6	-17.1		693.7	641.0	52.66	13.172	
7,400.0	7,243.3	7,338.1	7,264.5	32.5	29.0	-9.18		-1,920.6	-18.3		677.8	624.3	53.45	12.682	
7,500.0	7,343.2	7,419.4	7,345.7	32.8	29.3	-9.31		-1,916.8	-19.1		668.0	613.8	54.19	12.328	
7,601.3	7,444.5	7,502.3	7,428.7	33.1	29.6	-6.71		-1,915.2	-19.4		664.4	609.5	54.88	12.105	
7,641.3	7,484.5	7,539.2	7,465.5	33.2	29.7	-6.71		-1,915.2	-19.4		664.3	609.2	55.15	12.047	
7,700.0	7,543.2	7,597.9	7,524.2	33.4	29.9	-6.71		-1,915.2	-19.4		664.3	608.8	55.53	11.963	
7,800.0	7,643.2	7,697.9	7,624.2	33.7	30.2	-6.71		-1,915.2	-19.4		664.3	608.1	56.19	11.823	
7,900.0	7,743.2	7,797.9	7,724.2	33.9	30.5	-6.71		-1,915.2	-19.4		664.3	607.5	56.85	11.686	
8,000.0	7,843.2	7,897.9	7,824.2	34.2	30.8	-6.71		-1,915.2	-19.4		664.3	606.8	57.51	11.552	
8,100.0	7,943.2	7,997.9	7,924.2	34.5	31.1	-6.71		-1,915.2	-19.4		664.3	606.2	58.17	11.420	
8,200.0	8,043.2	8,097.9	8,024.2	34.8	31.4	-6.71		-1,915.2	-19.4		664.3	605.5	58.84	11.291	
8,300.0	8,143.2	8,197.9	8,124.2	35.1	31.7	-6.71		-1,915.2	-19.4		664.3	604.8	59.50	11.165	
8,400.0	8,243.2	8,297.9	8,224.2	35.4	32.0	-6.71		-1,915.2	-19.4		664.3	604.2	60.17	11.042	
8,500.0	8,343.2	8,397.9	8,324.2	35.7	32.3	-6.71		-1,915.2	-19.4		664.3	603.5	60.83	10.920	
8,600.0	8,443.2	8,497.9	8,424.2	36.0	32.6	-6.71		-1,915.2	-19.4		664.3	602.8	61.50	10.802	
8,700.0	8,543.2	8,597.9	8,524.2	36.3	32.9	-6.71		-1,915.2	-19.4		664.3	602.2	62.17	10.685	
8,800.0	8,643.2	8,697.9	8,624.2	36.6	33.2	-6.71		-1,915.2	-19.4		664.3	601.5	62.84	10.571	
8,907.3	8,750.5	8,805.2	8,731.5	36.9	33.5	-6.71		-1,915.2	-19.4		664.3	600.8	63.56	10.452	CC
8,925.0	8,768.2	8,822.9	8,749.2	37.0	33.6	-97.00		-1,915.2	-19.4		664.4	600.7	63.68	10.433	ES
8,950.0	8,793.1	8,847.8	8,774.1	37.0	33.7	-97.11		-1,915.2	-19.4		664.6	600.7	63.86	10.407	
8,975.0	8,817.9	8,872.6	8,798.9	37.1	33.7	-97.31		-1,915.2	-19.4		664.9	600.9	64.04	10.384	
9,000.0	8,842.6	8,897.3	8,823.6	37.2	33.8	-97.60		-1,915.2	-19.4		665.5	601.3	64.22	10.362	
9,025.0	8,867.0	8,921.7	8,848.0	37.2	33.9	-97.96		-1,915.2	-19.4		666.2	601.8	64.42	10.342	
9,050.0	8,891.1	8,945.8	8,872.1	37.3	34.0	-98.40		-1,915.2	-19.4		667.2	602.6	64.63	10.324	
9,075.0	8,914.7	8,969.4	8,895.7	37.4	34.0	-98.89		-1,915.2	-19.4		668.5	603.7	64.84	10.310	
9,100.0	8,938.0	8,992.7	8,919.0	37.5	34.1	-99.43		-1,915.2	-19.4		670.1	605.0	65.06	10.299	
9,125.0	8,960.7	9,015.4	8,941.7	37.5	34.2	-100.00		-1,915.2	-19.4		672.0	606.7	65.30	10.291	
9,150.0	8,982.9	9,037.5	8,963.9	37.6	34.2	-100.59		-1,915.2	-19.4		674.3	608.8	65.55	10.288	SF
9,175.0	9,004.4	9,059.1	8,985.4	37.7	34.3	-101.17		-1,915.2	-19.4		677.1	611.3	65.80	10.290	
9,200.0	9,025.2	9,079.9	9,006.2	37.7	34.4	-101.75		-1,915.2	-19.4		680.4	614.3	66.08	10.297	
9,225.0	9,045.3	9,099.9	9,026.3	37.8	34.4	-102.29		-1,915.2	-19.4		684.2	617.9	66.36	10.311	
9,250.0	9,064.5	9,119.2	9,045.5	37.8	34.5	-102.78		-1,915.2	-19.4		688.6	622.0	66.66	10.331	
9,275.0	9,082.9	9,137.6	9,063.9	37.9	34.6	-103.20		-1,915.2	-19.4		693.7	626.7	66.97	10.358	
9,300.0	9,100.4	9,155.1	9,081.4	38.0	34.6	-103.53		-1,915.2	-19.4		699.5	632.2	67.30	10.394	
9,325.0	9,116.9	9,171.6	9,097.9	38.0	34.7	-103.77		-1,915.2	-19.4		705.9	638.3	67.63	10.438	
9,350.0	9,132.4	9,187.1	9,113.4	38.1	34.7	-103.89		-1,915.2	-19.4		713.2	645.2	67.98	10.490	
9,375.0	9,146.9	9,201.6	9,127.9	38.1	34.8	-103.87		-1,915.2	-19.4		721.2	652.8	68.34	10.553	
9,400.0	9,160.3	9,215.0	9,141.3	38.2	34.8	-103.70		-1,915.2	-19.4		730.0	661.3	68.71	10.624	
9,425.0	9,172.5	9,227.2	9,153.5	38.2	34.8	-103.36		-1,915.2	-19.4		739.6	670.5	69.08	10.706	
9,450.0	9,183.7	9,238.3	9,164.7	38.3	34.9	-102.84		-1,915.2	-19.4		750.0	680.5	69.46	10.798	
9,475.0	9,193.6	9,248.3	9,174.6	38.4	34.9	-102.13		-1,915.2	-19.4		761.2	691.4	69.83	10.900	
9,500.0	9,202.3	9,257.0	9,183.3	38.4	34.9	-101.20		-1,915.2	-19.4		773.2	703.0	70.21	11.013	

CC - Min centre to center distance or convergent point, SF - min separation factor, ES - min ellipse separation

Anticollision Report

Company:	NEW MEXICO	Local Co-ordinate Reference:	Well SILVER BAR 35-36 FED STATE COM 133H
Project:	(SP) EDDY	TVD Reference:	kb @ 3358.0usft
Reference Site:	SILVER BAR	MD Reference:	kb @ 3358.0usft
Site Error:	0.0 usft	North Reference:	Grid
Reference Well:	SILVER BAR 35-36 FED STATE COM 133H	Survey Calculation Method:	Minimum Curvature
Well Error:	0.0 usft	Output errors are at	2.00 sigma
Reference Wellbore	owb	Database:	Compass_17
Reference Design:	PWP0	Offset TVD Reference:	Offset Datum

Offset Design: IRONHORSE 35-36 FED STATE - xxIRONHORSE 35-36 FED STATE COM 174H - OWB - PWP0												Offset Site Error:	0.0 usft
Survey Program: 0-MWD												Offset Well Error:	0.0 usft
Measured Reference Depth (usft)	Vertical Depth (usft)	Offset		Semi Major Axis		Highside Toolface (°)	Offset Wellbore Centre		Rule Assigned: Distance		Minimum Separation (usft)	Separation Factor	Warning
		Measured Depth (usft)	Vertical Depth (usft)	Reference (usft)	Offset (usft)		+N/-S (usft)	+E/-W (usft)	Between Centres (usft)	Between Ellipses (usft)			
9,525.0	9,209.7	9,264.4	9,190.7	38.5	34.9	-100.06	1,915.2	-19.4	785.9	715.3	70.57	11.135	
9,550.0	9,216.0	9,270.6	9,197.0	38.6	35.0	-98.68	1,915.2	-19.4	799.3	728.4	70.94	11.268	
9,575.0	9,220.9	9,275.6	9,201.9	38.6	35.0	-97.06	1,915.2	-19.4	813.4	742.1	71.29	11.410	
9,600.0	9,224.5	9,279.2	9,205.5	38.7	35.0	-95.20	1,915.2	-19.4	828.1	756.5	71.63	11.561	
9,625.0	9,226.9	9,281.6	9,207.9	38.8	35.0	-93.09	1,915.2	-19.4	843.4	771.5	71.96	11.720	
9,650.0	9,227.9	9,282.6	9,208.9	38.9	35.0	-90.73	1,915.2	-19.4	859.2	786.9	72.28	11.888	
9,657.3	9,228.0	9,282.7	9,209.0	38.9	35.0	-90.00	1,915.2	-19.4	863.9	791.6	72.37	11.938	
9,700.0	9,228.0	9,282.7	9,209.0	39.1	35.0	-90.00	1,915.2	-19.4	892.1	819.2	72.87	12.243	
9,800.0	9,228.0	9,282.7	9,209.0	39.7	35.0	-90.00	1,915.2	-19.4	962.3	888.4	73.93	13.016	

CC - Min centre to center distance or covergent point, SF - min separation factor, ES - min ellipse separation

Anticollision Report

Company:	NEW MEXICO	Local Co-ordinate Reference:	Well SILVER BAR 35-36 FED STATE COM 133H
Project:	(SP) EDDY	TVD Reference:	kb @ 3358.0usft
Reference Site:	SILVER BAR	MD Reference:	kb @ 3358.0usft
Site Error:	0.0 usft	North Reference:	Grid
Reference Well:	SILVER BAR 35-36 FED STATE COM 133H	Survey Calculation Method:	Minimum Curvature
Well Error:	0.0 usft	Output errors are at	2.00 sigma
Reference Wellbore	owb	Database:	Compass_17
Reference Design:	PWP0	Offset TVD Reference:	Offset Datum

Offset Design: SILVER BAR - BLACK DIAMOND 34 FED COM 133H - AWB - AWB													Offset Site Error:	0.0 usft		
Survey Program: 15-MWVD													Rule Assigned:		Offset Well Error:	0.0 usft
Measured Depth (usft)	Vertical Depth (usft)	Measured Depth (usft)	Vertical Depth (usft)	Semi Reference (usft)	Major Axis Offset (usft)	Highside Toolface (°)	Offset Wellbore Centre +N/-S (usft)	+E/-W (usft)	Distance Between Centres (usft)	Between Ellipses (usft)	Minimum Separation (usft)	Separation Factor	Warning			
0.0	0.0	0.0	0.0	0.0	0.0	-0.11	79.6	-0.1	79.9							
100.0	100.0	94.3	94.3	0.3	0.2	-0.50	79.5	-0.7	79.5	79.0	0.50	159.775				
200.0	200.0	194.5	194.5	0.6	0.6	-1.78	78.9	-2.5	79.0	77.8	1.22	64.926				
300.0	300.0	294.7	294.7	1.0	1.0	-3.24	78.1	-4.4	78.2	76.3	1.94	40.415				
400.0	400.0	394.8	394.7	1.3	1.3	-4.67	77.0	-6.3	77.3	74.6	2.65	29.125				
500.0	500.0	494.5	494.4	1.7	1.7	-5.87	76.2	-7.8	76.6	73.2	3.37	22.713				
600.0	600.0	594.2	594.1	2.0	2.0	-6.55	75.8	-8.7	76.3	72.2	4.09	18.671				
700.0	700.0	694.2	694.1	2.4	2.4	-6.72	75.6	-8.9	76.2	71.4	4.80	15.875				
800.0	800.0	794.2	794.1	2.8	2.7	-6.35	75.5	-8.4	75.9	70.5	5.49	13.840				
865.4	865.4	859.5	859.4	3.0	2.9	-5.82	75.5	-7.7	75.9	69.9	5.94	12.777				
900.0	900.0	894.1	894.0	3.1	3.1	-5.43	75.6	-7.2	75.9	69.7	6.18	12.283				
1,000.0	1,000.0	994.3	994.2	3.5	3.4	-3.67	75.6	-4.9	75.8	68.9	6.88	11.016				
1,100.0	1,100.0	1,094.3	1,094.1	3.8	3.7	-0.93	75.4	-1.2	75.4	67.8	7.58	9.954				
1,124.4	1,124.4	1,118.6	1,118.4	3.9	3.8	-0.22	75.4	-0.3	75.4	67.7	7.75	9.731				
1,200.0	1,200.0	1,193.8	1,193.5	4.2	4.1	1.90	75.6	2.5	75.6	67.4	8.28	9.135				
1,300.0	1,300.0	1,293.7	1,293.4	4.6	4.4	4.40	76.2	5.9	76.5	67.5	8.99	8.509				
1,400.0	1,400.0	1,394.2	1,393.8	4.9	4.8	6.56	76.5	8.8	77.0	67.3	9.70	7.942				
1,500.0	1,500.0	1,494.9	1,494.5	5.3	5.1	8.58	75.9	11.5	76.8	66.4	10.41	7.376				
1,600.0	1,600.0	1,595.2	1,594.8	5.6	5.5	10.65	74.5	14.0	75.9	64.7	11.12	6.819				
1,700.0	1,700.0	1,695.2	1,694.7	6.0	5.9	12.86	73.0	16.7	74.9	63.0	11.84	6.324				
1,800.0	1,800.0	1,795.4	1,794.8	6.3	6.2	15.21	71.3	19.4	73.9	61.3	12.55	5.885				
1,900.0	1,900.0	1,895.6	1,895.0	6.7	6.6	17.61	69.2	22.0	72.6	59.3	13.27	5.472				
2,000.0	2,000.0	1,995.7	1,995.1	7.1	6.9	20.01	66.8	24.3	71.1	57.1	13.98	5.085				
2,056.6	2,056.6	2,050.0	2,049.3	7.3	7.1	18.70	65.9	25.6	70.2	55.8	14.38	4.882				
2,100.0	2,100.0	2,091.8	2,091.1	7.4	7.3	19.51	67.1	26.7	70.7	56.0	14.67	4.815				
2,200.0	2,199.8	2,192.0	2,191.2	7.8	7.6	22.32	70.1	29.8	69.7	54.3	15.38	4.533				
2,300.0	2,299.5	2,289.5	2,288.5	8.1	8.0	26.19	74.6	33.3	67.5	51.5	16.06	4.206				
2,400.0	2,398.7	2,389.4	2,388.2	8.5	8.3	31.58	80.6	37.3	64.0	47.3	16.77	3.820				
2,500.0	2,497.5	2,487.4	2,485.8	8.9	8.6	38.27	88.6	41.3	60.1	42.6	17.44	3.445				
2,600.0	2,595.6	2,586.8	2,584.6	9.2	9.0	47.70	97.5	45.4	55.3	37.1	18.16	3.046				
2,700.0	2,693.1	2,685.7	2,683.1	9.6	9.4	61.69	106.7	49.6	50.7	31.8	18.90	2.681				
2,750.0	2,741.5	2,735.1	2,732.2	9.8	9.5	70.69	111.3	51.7	49.2	29.9	19.29	2.552				
2,782.6	2,773.0	2,767.2	2,764.2	9.9	9.6	77.02	114.3	53.0	48.9	29.4	19.55	2.503 CC				
2,800.0	2,789.8	2,784.3	2,781.2	10.0	9.7	80.38	116.0	53.7	49.0	29.3	19.68	2.490 ES, SF				
2,900.0	2,886.4	2,883.0	2,879.2	10.4	10.1	98.54	125.5	57.9	52.7	32.2	20.47	2.574				
3,000.0	2,982.9	2,981.7	2,977.4	10.9	10.4	112.86	135.4	62.0	60.7	39.5	21.23	2.860				
3,100.0	3,079.5	3,080.5	3,075.6	11.3	10.8	123.17	145.7	66.2	71.4	49.4	21.97	3.248				
3,200.0	3,176.1	3,179.2	3,173.6	11.7	11.1	130.60	156.0	70.3	83.8	61.0	22.71	3.688				
3,300.0	3,272.7	3,278.0	3,271.8	12.2	11.5	136.04	166.3	74.6	97.2	73.8	23.44	4.147				
3,400.0	3,369.3	3,377.1	3,370.3	12.6	11.9	140.00	177.1	78.9	111.0	86.8	24.17	4.592				
3,500.0	3,465.9	3,476.1	3,468.5	13.1	12.3	143.06	188.0	83.1	124.9	100.0	24.91	5.015				
3,600.0	3,562.5	3,574.6	3,566.4	13.6	12.6	145.79	198.5	86.7	139.2	113.6	25.64	5.430				
3,700.0	3,659.1	3,672.9	3,664.1	14.0	13.0	148.27	208.4	89.8	154.1	127.7	26.37	5.842				
3,800.0	3,755.7	3,771.0	3,761.7	14.5	13.4	150.40	217.9	92.9	169.5	142.4	27.10	6.253				
3,900.0	3,852.3	3,868.6	3,858.8	15.0	13.7	152.27	226.8	95.7	185.4	157.6	27.83	6.664				
4,000.0	3,948.9	3,965.8	3,955.7	15.5	14.1	154.01	234.9	98.3	202.2	173.7	28.55	7.083				
4,100.0	4,045.5	4,064.3	4,053.8	16.0	14.5	155.43	242.9	101.2	219.5	190.2	29.28	7.495				
4,200.0	4,142.1	4,166.9	4,155.6	16.5	14.8	155.70	254.1	107.6	235.4	205.3	30.06	7.830				
4,300.0	4,238.6	4,265.0	4,252.8	17.0	15.2	155.64	265.4	114.7	251.0	220.2	30.84	8.140				
4,400.0	4,335.2	4,362.7	4,349.7	17.5	15.6	155.71	276.2	121.3	267.0	235.4	31.61	8.447				
4,500.0	4,431.8	4,460.5	4,446.7	18.0	16.0	155.81	286.6	127.9	283.3	250.9	32.38	8.750				

CC - Min centre to center distance or convergent point, SF - min separation factor, ES - min ellipse separation

Anticollision Report

Company:	NEW MEXICO	Local Co-ordinate Reference:	Well SILVER BAR 35-36 FED STATE COM 133H
Project:	(SP) EDDY	TVD Reference:	kb @ 3358.0usft
Reference Site:	SILVER BAR	MD Reference:	kb @ 3358.0usft
Site Error:	0.0 usft	North Reference:	Grid
Reference Well:	SILVER BAR 35-36 FED STATE COM 133H	Survey Calculation Method:	Minimum Curvature
Well Error:	0.0 usft	Output errors are at	2.00 sigma
Reference Wellbore	owb	Database:	Compass_17
Reference Design:	PWPO	Offset TVD Reference:	Offset Datum

Offset Design: SILVER BAR - BLACK DIAMOND 34 FED COM 133H - AWB - AWB													Offset Site Error:	0.0 usft
Survey Program: 15-MWVD										Rule Assigned:		Offset Well Error:		0.0 usft
Measured Reference Depth (usft)	Vertical Depth (usft)	Measured Offset Depth (usft)	Vertical Offset Depth (usft)	Semi Reference (usft)	Major Axis Offset (usft)	Highside Toolface (°)	Offset Wellbore Centre		Distance Between Centres (usft)		Minimum Separation (usft)	Separation Factor	Warning	
							+N/-S (usft)	+E/-W (usft)	Between Centres (usft)	Between Ellipses (usft)				
4,600.0	4,528.4	4,558.4	4,543.9	18.5	16.4	155.88	296.9	134.7	299.9	266.8	33.15	9.047		
4,700.0	4,625.0	4,656.7	4,641.4	19.0	16.8	156.03	306.8	141.2	316.7	282.8	33.93	9.335		
4,800.0	4,721.6	4,755.2	4,739.2	19.5	17.1	156.33	316.3	146.8	333.5	298.8	34.69	9.614		
4,900.0	4,818.2	4,854.1	4,837.5	20.0	17.5	156.63	325.9	152.3	350.4	314.9	35.46	9.880		
5,000.0	4,914.8	4,954.0	4,936.8	20.5	17.9	156.88	335.8	157.8	367.0	330.7	36.24	10.128		
5,100.0	5,011.4	5,055.3	5,037.4	21.0	18.3	157.11	346.4	163.3	383.1	346.0	37.02	10.348		
5,200.0	5,108.0	5,156.1	5,137.5	21.5	18.7	157.34	357.5	168.5	398.5	360.7	37.80	10.543		
5,300.0	5,204.6	5,256.0	5,236.6	22.0	19.1	157.60	368.8	173.1	413.6	375.0	38.57	10.722		
5,400.0	5,301.2	5,354.7	5,334.6	22.5	19.5	157.90	379.9	177.2	428.5	389.2	39.34	10.894		
5,500.0	5,397.8	5,452.1	5,431.4	23.0	19.8	158.27	390.4	180.6	443.7	403.6	40.09	11.068		
5,600.0	5,494.4	5,548.1	5,526.9	23.5	20.2	158.72	400.1	183.3	459.3	418.5	40.83	11.250		
5,700.0	5,590.9	5,643.0	5,621.3	24.1	20.6	159.24	408.8	185.4	475.7	434.1	41.55	11.448		
5,800.0	5,687.5	5,737.0	5,715.0	24.6	20.9	159.77	416.5	187.2	492.9	450.7	42.27	11.662		
5,900.0	5,784.1	5,830.7	5,808.4	25.1	21.3	160.22	423.5	189.7	511.1	468.1	42.98	11.892		
6,000.0	5,880.7	5,931.6	5,908.8	25.6	21.7	160.49	431.3	194.1	529.5	485.7	43.75	12.101		
6,100.0	5,977.3	6,029.9	6,006.8	26.1	22.0	160.72	439.2	198.4	547.6	503.1	44.51	12.303		
6,200.0	6,073.9	6,127.0	6,103.6	26.7	22.4	161.04	446.6	201.6	565.9	520.6	45.25	12.505		
6,300.0	6,170.5	6,222.7	6,198.9	27.2	22.8	161.45	453.3	203.8	584.5	538.5	45.97	12.713		
6,400.0	6,267.1	6,319.4	6,295.4	27.7	23.1	161.80	460.1	206.5	603.3	556.6	46.71	12.916		
6,500.0	6,363.7	6,413.4	6,389.1	28.2	23.5	162.00	466.3	210.5	622.7	575.3	47.43	13.129		
6,600.0	6,460.3	6,515.9	6,491.4	28.7	23.9	162.29	472.9	213.9	642.2	594.0	48.21	13.322		
6,700.0	6,556.9	6,621.5	6,596.6	29.3	24.3	162.63	481.2	216.3	660.0	611.0	49.00	13.468		
6,800.0	6,653.5	6,695.5	6,670.4	29.8	24.5	162.91	485.6	217.8	679.7	630.1	49.56	13.713		
6,851.3	6,703.0	6,771.1	6,745.7	30.1	24.8	163.02	490.5	221.2	689.8	639.7	50.14	13.758		
6,900.0	6,750.2	6,808.8	6,783.2	30.3	25.0	163.04	493.5	223.6	698.5	648.1	50.45	13.846		
7,000.0	6,847.6	6,896.4	6,870.5	30.8	25.3	163.08	499.1	228.9	715.5	664.3	51.13	13.993		
7,100.0	6,945.7	6,989.4	6,963.3	31.3	25.6	163.12	503.7	233.6	730.2	678.4	51.84	14.088		
7,200.0	7,044.5	7,090.7	7,064.3	31.7	26.0	163.04	508.4	239.3	742.1	689.5	52.61	14.107		
7,300.0	7,143.7	7,214.2	7,186.7	32.1	26.5	162.30	518.9	251.5	747.9	694.3	53.59	13.956		
7,400.0	7,243.3	7,331.0	7,302.7	32.5	27.0	161.66	530.4	260.3	748.7	694.3	54.47	13.745		
7,500.0	7,343.2	7,426.4	7,397.5	32.8	27.3	161.32	539.9	263.6	745.1	689.9	55.19	13.501		
7,601.3	7,444.5	7,516.5	7,487.2	33.1	27.7	163.68	547.3	265.5	739.4	683.5	55.86	13.237		
7,700.0	7,543.2	7,603.4	7,574.0	33.4	28.0	163.49	552.9	266.4	733.6	677.2	56.47	12.991		
7,800.0	7,643.2	7,712.7	7,683.1	33.7	28.4	163.29	559.5	267.2	728.0	670.8	57.24	12.720		
7,900.0	7,743.2	7,810.4	7,780.6	33.9	28.7	163.18	565.6	266.7	721.9	664.0	57.91	12.466		
8,000.0	7,843.2	7,923.5	7,893.3	34.2	29.1	162.98	574.2	266.8	714.6	656.0	58.69	12.177		
8,100.0	7,943.2	8,009.9	7,979.5	34.5	29.5	162.75	580.8	267.6	707.7	648.3	59.32	11.930		
8,200.0	8,043.2	8,095.6	8,064.9	34.8	29.8	162.26	586.6	272.1	702.7	642.7	59.96	11.720		
8,300.0	8,143.2	8,188.9	8,157.8	35.1	30.1	161.58	592.1	279.1	699.4	638.8	60.66	11.530		
8,400.0	8,243.2	8,286.7	8,255.1	35.4	30.5	160.88	597.4	286.3	696.6	635.2	61.40	11.345		
8,500.0	8,343.2	8,370.2	8,338.3	35.7	30.8	160.37	600.7	291.7	695.1	633.1	61.99	11.212		
8,505.6	8,348.8	8,374.6	8,342.8	35.7	30.8	160.35	600.8	291.9	695.1	633.0	62.02	11.207		
8,600.0	8,443.2	8,456.5	8,424.5	36.0	31.1	160.03	601.2	295.9	696.2	633.6	62.56	11.127		
8,700.0	8,543.2	8,773.8	8,724.5	36.3	32.0	165.82	622.1	218.2	679.5	616.6	62.89	10.805		
8,800.0	8,643.2	8,865.9	8,800.5	36.6	32.2	170.11	631.1	167.0	654.4	590.9	63.46	10.311		
8,907.3	8,750.5	8,993.1	8,894.9	36.9	32.4	177.63	646.2	83.4	628.0	563.9	64.04	9.806		
8,925.0	8,768.2	9,023.7	8,915.1	37.0	32.4	90.06	650.7	60.8	623.7	559.6	64.13	9.726		
8,950.0	8,793.1	9,057.0	8,934.9	37.0	32.5	93.41	656.3	34.8	617.6	553.2	64.36	9.596		
8,975.0	8,817.9	9,069.3	8,942.0	37.1	32.5	95.10	658.4	24.9	612.1	547.5	64.65	9.469		
9,000.0	8,842.6	9,080.6	8,948.6	37.2	32.5	96.63	660.4	15.9	607.5	542.6	64.91	9.360		
9,025.0	8,867.0	9,090.9	8,954.6	37.2	32.6	97.97	662.3	7.8	603.9	538.7	65.13	9.272		

CC - Min centre to center distance or convergent point, SF - min separation factor, ES - min ellipse separation

Anticollision Report

Company:	NEW MEXICO	Local Co-ordinate Reference:	Well SILVER BAR 35-36 FED STATE COM 133H
Project:	(SP) EDDY	TVD Reference:	kb @ 3358.0usft
Reference Site:	SILVER BAR	MD Reference:	kb @ 3358.0usft
Site Error:	0.0 usft	North Reference:	Grid
Reference Well:	SILVER BAR 35-36 FED STATE COM 133H	Survey Calculation Method:	Minimum Curvature
Well Error:	0.0 usft	Output errors are at	2.00 sigma
Reference Wellbore	owb	Database:	Compass_17
Reference Design:	PWP0	Offset TVD Reference:	Offset Datum

Offset Design: SILVER BAR - BLACK DIAMOND 34 FED COM 133H - AWB - AWB													Offset Site Error:	0.0 usft		
Survey Program: 15-MWDD													Rule Assigned:		Offset Well Error:	0.0 usft
Measured Reference Depth (usft)	Vertical Reference Depth (usft)	Measured Offset Depth (usft)	Vertical Offset Depth (usft)	Semi Reference (usft)	Major Axis Offset (usft)	Highside Toolface (°)	Offset Wellbore Centre		Distance Between Centres (usft)	Distance Between Ellipses (usft)	Minimum Separation (usft)	Separation Factor	Warning			
9,050.0	8,891.1	9,100.6	8,960.2	37.3	32.6	99.15	664.0	0.0	601.3	536.0	65.31	9.206				
9,075.0	8,914.7	9,109.5	8,965.2	37.4	32.6	100.14	665.6	-7.1	599.8	534.4	65.45	9.164				
9,093.5	8,932.0	9,115.0	8,968.3	37.4	32.6	100.70	666.6	-11.6	599.5	534.0	65.52	9.150				
9,100.0	8,938.0	9,116.6	8,969.1	37.5	32.6	100.84	666.9	-12.9	599.5	534.0	65.54	9.148				
9,125.0	8,960.7	9,120.8	8,971.4	37.5	32.6	101.13	667.7	-16.4	600.5	534.9	65.55	9.161				
9,150.0	8,982.9	9,123.1	8,972.6	37.6	32.6	101.08	668.2	-18.3	602.7	537.2	65.49	9.203				
9,175.0	9,004.4	9,123.9	8,973.0	37.7	32.6	100.74	668.3	-18.9	606.2	540.8	65.36	9.274				
9,200.0	9,025.2	9,123.4	8,972.8	37.7	32.6	100.12	668.2	-18.5	610.9	545.7	65.18	9.374				
9,225.0	9,045.3	9,121.9	8,971.9	37.8	32.6	99.25	667.9	-17.2	616.9	551.9	64.94	9.500				
9,250.0	9,064.5	9,119.5	8,970.7	37.8	32.6	98.15	667.5	-15.3	623.9	559.3	64.65	9.650				
9,275.0	9,082.9	9,116.2	8,968.9	37.9	32.6	96.82	666.9	-12.6	632.1	567.7	64.34	9.824				
9,300.0	9,100.4	9,112.2	8,966.7	38.0	32.6	95.27	666.1	-9.3	641.2	577.2	64.00	10.019				
9,325.0	9,116.9	9,107.6	8,964.2	38.0	32.6	93.53	665.3	-5.6	651.2	587.6	63.65	10.232				
9,350.0	9,132.4	9,102.3	8,961.1	38.1	32.6	91.59	664.3	-1.3	662.1	598.8	63.29	10.461				
9,375.0	9,146.9	9,096.0	8,957.6	38.1	32.6	89.46	663.2	3.7	673.7	610.7	62.93	10.704				
9,400.0	9,160.3	9,088.2	8,953.0	38.2	32.6	87.10	661.8	9.9	685.8	623.3	62.55	10.964				
9,425.0	9,172.5	9,076.3	8,946.1	38.2	32.5	84.33	659.7	19.4	698.5	636.4	62.11	11.247				
9,450.0	9,183.7	9,062.7	8,938.3	38.3	32.5	81.43	657.3	30.2	711.6	649.9	61.65	11.542				
9,475.0	9,193.6	9,051.1	8,931.6	38.4	32.5	78.70	655.2	39.4	724.8	663.5	61.28	11.828				
9,500.0	9,202.3	9,040.5	8,925.4	38.4	32.5	76.06	653.4	47.9	738.3	677.3	60.98	12.108				
9,525.0	9,209.7	9,032.1	8,920.3	38.5	32.5	73.61	652.0	54.4	751.9	691.1	60.77	12.373				
9,550.0	9,216.0	9,024.6	8,915.6	38.6	32.5	71.24	650.8	60.2	765.7	705.0	60.63	12.628				
9,575.0	9,220.9	9,015.2	8,909.6	38.6	32.4	68.81	649.4	67.3	779.5	719.0	60.48	12.887				
9,600.0	9,224.5	9,006.7	8,904.1	38.7	32.4	66.50	648.1	73.6	793.2	732.8	60.40	13.133				
9,625.0	9,226.9	8,998.0	8,898.2	38.8	32.4	64.25	646.9	79.9	807.0	746.6	60.35	13.371				
9,650.0	9,227.9	8,988.9	8,892.0	38.9	32.4	62.07	645.6	86.3	820.6	760.3	60.33	13.602				
9,657.3	9,228.0	8,984.6	8,889.0	38.9	32.4	61.38	645.0	89.4	824.5	764.3	60.28	13.679				
9,700.0	9,228.0	8,957.7	8,870.2	39.1	32.3	60.19	641.3	108.3	847.8	787.8	59.98	14.136				
9,800.0	9,228.0	8,925.6	8,847.0	39.7	32.3	58.74	637.3	130.1	905.4	845.2	60.19	15.042				
9,900.0	9,228.0	8,885.6	8,816.0	40.4	32.2	56.86	633.1	155.0	967.8	907.6	60.20	16.075				

CC - Min centre to center distance or convergent point, SF - min separation factor, ES - min ellipse separation

Anticollision Report

Company:	NEW MEXICO	Local Co-ordinate Reference:	Well SILVER BAR 35-36 FED STATE COM 133H
Project:	(SP) EDDY	TVD Reference:	kb @ 3358.0usft
Reference Site:	SILVER BAR	MD Reference:	kb @ 3358.0usft
Site Error:	0.0 usft	North Reference:	Grid
Reference Well:	SILVER BAR 35-36 FED STATE COM 133H	Survey Calculation Method:	Minimum Curvature
Well Error:	0.0 usft	Output errors are at	2.00 sigma
Reference Wellbore	owb	Database:	Compass_17
Reference Design:	PWP0	Offset TVD Reference:	Offset Datum

Offset Design: SILVER BAR - BLACK DIAMOND 34 FED COM 134H - AWB - AWB														Offset Site Error:	0.0 usft
Survey Program: 15-MWDD														Offset Well Error:	0.0 usft
Measured Depth (usft)	Vertical Depth (usft)	Measured Depth (usft)	Vertical Depth (usft)	Semi Reference (usft)	Major Axis Offset (usft)	Highside Toolface (°)	Offset Wellbore Centre		Distance Between Centres (usft)		Minimum Separation (usft)	Separation Factor	Warning		
0.0	0.0	0.0	0.0	0.0	0.0	-0.22	34.6	-0.1	35.1						
100.0	100.0	94.0	94.0	0.3	0.2	-0.71	34.6	-0.4	34.6	34.1	0.50	69.656			
198.7	198.7	192.7	192.7	0.6	0.6	-2.29	34.4	-1.4	34.5	33.3	1.20	28.612			
200.0	200.0	194.0	194.0	0.6	0.6	-2.31	34.4	-1.4	34.5	33.2	1.21	28.395			
300.0	300.0	293.9	293.9	1.0	1.0	-4.11	34.7	-2.5	34.8	32.9	1.93	18.059			
400.0	400.0	394.2	394.1	1.3	1.3	-5.56	34.6	-3.4	34.8	32.2	2.65	13.149			
500.0	500.0	494.1	494.0	1.7	1.7	-6.65	34.3	-4.0	34.5	31.2	3.36	10.275			
530.2	530.2	524.2	524.2	1.8	1.8	-6.91	34.3	-4.2	34.5	30.9	3.58	9.650			
600.0	600.0	593.9	593.9	2.0	2.0	-7.33	34.3	-4.4	34.6	30.5	4.08	8.493			
700.0	700.0	693.6	693.6	2.4	2.4	-6.73	35.1	-4.1	35.4	30.6	4.77	7.413			
800.0	800.0	793.5	793.5	2.8	2.7	-5.08	36.6	-3.2	36.7	31.2	5.47	6.709			
900.0	900.0	893.4	893.3	3.1	3.1	-2.90	38.3	-1.9	38.4	32.2	6.17	6.216			
1,000.0	1,000.0	993.5	993.4	3.5	3.4	0.21	40.0	0.1	40.0	33.2	6.87	5.824			
1,100.0	1,100.0	1,093.6	1,093.4	3.8	3.7	4.35	41.4	3.1	41.5	34.0	7.58	5.480			
1,200.0	1,200.0	1,193.8	1,193.6	4.2	4.1	7.60	42.3	5.7	42.7	34.4	8.29	5.155			
1,300.0	1,300.0	1,294.0	1,293.8	4.6	4.4	9.30	42.9	7.0	43.5	34.5	8.99	4.836			
1,400.0	1,400.0	1,394.2	1,394.0	4.9	4.8	11.01	43.0	8.4	43.8	34.1	9.70	4.510			
1,500.0	1,500.0	1,494.2	1,494.0	5.3	5.1	13.19	42.5	10.0	43.7	33.3	10.41	4.198			
1,600.0	1,600.0	1,594.3	1,594.0	5.6	5.5	15.88	42.0	12.0	43.7	32.6	11.12	3.929			
1,700.0	1,700.0	1,694.4	1,694.1	6.0	5.8	18.90	41.1	14.1	43.5	31.7	11.83	3.676			
1,800.0	1,800.0	1,794.5	1,794.2	6.3	6.2	22.36	39.9	16.4	43.1	30.6	12.54	3.439			
1,900.0	1,900.0	1,894.5	1,894.1	6.7	6.5	26.35	38.3	19.0	42.8	29.5	13.25	3.227			
2,000.0	2,000.0	1,994.5	1,994.0	7.1	6.9	30.77	36.5	21.8	42.5	28.6	13.96	3.046			
2,100.0	2,100.0	2,094.3	2,093.8	7.4	7.3	34.07	34.7	24.7	41.1	26.5	14.67	2.803			
2,200.0	2,199.8	2,193.8	2,193.2	7.8	7.6	43.99	33.0	27.9	38.0	22.6	15.38	2.469			
2,300.0	2,299.5	2,292.8	2,292.2	8.1	8.0	56.25	33.9	30.9	35.3	19.2	16.08	2.193			
2,400.0	2,398.7	2,392.7	2,392.0	8.5	8.3	74.10	35.5	33.7	33.3	16.5	16.80	1.985			
2,477.0	2,474.8	2,470.2	2,469.5	8.8	8.6	98.02	33.8	32.8	31.5	14.2	17.34	1.820	CC, ES, SF		
2,500.0	2,497.5	2,492.8	2,492.1	8.9	8.7	106.31	33.1	32.2	31.9	14.4	17.50	1.822			
2,600.0	2,595.6	2,590.3	2,589.5	9.2	9.0	137.94	30.1	29.0	41.6	23.4	18.20	2.287			
2,700.0	2,693.1	2,686.9	2,686.0	9.6	9.3	156.27	27.0	25.5	61.9	43.0	18.88	3.278			
2,750.0	2,741.5	2,734.8	2,733.8	9.8	9.5	161.84	25.4	23.6	74.6	55.4	19.22	3.883			
2,800.0	2,789.8	2,782.5	2,781.5	10.0	9.6	165.97	23.8	21.7	88.3	68.7	19.55	4.514			
2,900.0	2,886.4	2,878.0	2,876.8	10.4	10.0	171.36	20.5	17.7	116.4	96.2	20.23	5.756			
3,000.0	2,982.9	2,977.4	2,976.1	10.9	10.3	174.39	17.6	14.5	144.7	123.7	20.94	6.911			
3,100.0	3,079.5	3,073.8	3,072.5	11.3	10.7	174.94	17.3	15.4	170.9	149.2	21.63	7.898			
3,200.0	3,176.1	3,170.0	3,168.7	11.7	11.0	175.27	16.7	16.5	197.3	175.0	22.33	8.835			
3,300.0	3,272.7	3,266.2	3,264.9	12.2	11.3	175.55	15.9	17.5	223.9	200.8	23.03	9.721			
3,400.0	3,369.3	3,362.5	3,361.2	12.6	11.7	175.78	15.2	18.5	250.5	226.8	23.73	10.554			
3,500.0	3,465.9	3,458.7	3,457.4	13.1	12.0	175.98	14.3	19.4	277.2	252.7	24.44	11.341			
3,600.0	3,562.5	3,554.9	3,553.6	13.6	12.4	176.14	13.4	20.4	303.9	278.8	25.14	12.087			
3,700.0	3,659.1	3,651.5	3,650.2	14.0	12.7	176.26	12.6	21.4	330.6	304.8	25.85	12.788			
3,800.0	3,755.7	3,747.4	3,746.1	14.5	13.0	176.34	11.7	22.5	357.3	330.7	26.56	13.452			
3,900.0	3,852.3	3,842.2	3,840.9	15.0	13.4	176.39	10.6	23.8	384.3	357.0	27.26	14.097			
4,000.0	3,948.9	3,938.6	3,937.2	15.5	13.7	176.40	9.2	25.3	411.6	383.6	27.97	14.713			
4,100.0	4,045.5	4,037.6	4,036.1	16.0	14.1	176.41	8.1	26.9	438.5	409.7	28.71	15.273			
4,200.0	4,142.1	4,132.8	4,131.3	16.5	14.4	176.39	7.5	28.6	465.0	435.6	29.42	15.807			
4,300.0	4,238.6	4,208.6	4,207.1	17.0	14.7	176.25	5.2	31.0	493.7	463.8	29.97	16.476			
4,400.0	4,335.2	4,301.3	4,299.6	17.5	15.0	175.96	0.3	35.2	524.8	494.1	30.65	17.119			
4,500.0	4,431.8	4,376.7	4,374.7	18.0	15.3	175.69	-4.6	39.2	557.1	525.9	31.17	17.873			
4,600.0	4,528.4	4,471.2	4,468.6	18.5	15.6	175.29	-13.1	45.0	591.7	559.8	31.88	18.558			

CC - Min centre to center distance or convergent point, SF - min separation factor, ES - min ellipse separation

Anticollision Report

Company:	NEW MEXICO	Local Co-ordinate Reference:	Well SILVER BAR 35-36 FED STATE COM 133H
Project:	(SP) EDDY	TVD Reference:	kb @ 3358.0usft
Reference Site:	SILVER BAR	MD Reference:	kb @ 3358.0usft
Site Error:	0.0 usft	North Reference:	Grid
Reference Well:	SILVER BAR 35-36 FED STATE COM 133H	Survey Calculation Method:	Minimum Curvature
Well Error:	0.0 usft	Output errors are at	2.00 sigma
Reference Wellbore	owb	Database:	Compass_17
Reference Design:	PWP0	Offset TVD Reference:	Offset Datum

Offset Design: SILVER BAR - BLACK DIAMOND 34 FED COM 134H - AWB - AWB													Offset Site Error:	0.0 usft
Survey Program: 15-MWD													Offset Well Error:	0.0 usft
Reference		Offset		Semi Major Axis		Highside Toolface (°)	Offset Wellbore Centre		Rule Assigned: Distance		Minimum Separation (usft)	Separation Factor	Warning	
Measured Depth (usft)	Vertical Depth (usft)	Measured Depth (usft)	Vertical Depth (usft)	Reference (usft)	Offset (usft)		+N/-S (usft)	+E/-W (usft)	Between Centres (usft)	Between Ellipses (usft)				
4,700.0	4,625.0	4,569.6	4,566.4	19.0	16.0	174.87	-21.5	51.7	625.8	593.2	32.64	19.176		
4,800.0	4,721.6	4,667.8	4,664.1	19.5	16.4	174.47	-29.1	58.7	659.3	625.9	33.39	19.748		
4,900.0	4,818.2	4,746.2	4,742.1	20.0	16.7	174.22	-35.1	63.7	692.9	658.9	33.94	20.414		
5,000.0	4,914.8	4,832.7	4,828.0	20.5	17.0	174.18	-44.5	66.9	729.1	694.6	34.57	21.091		
5,100.0	5,011.4	4,928.9	4,923.6	21.0	17.3	174.20	-54.9	69.7	765.2	729.9	35.30	21.676		
5,200.0	5,108.0	5,014.2	5,008.5	21.5	17.6	174.23	-63.8	72.0	801.1	765.2	35.92	22.301		
5,300.0	5,204.6	5,086.9	5,080.4	22.0	17.9	174.26	-73.9	74.0	839.9	803.5	36.41	23.070		
5,400.0	5,301.2	5,186.6	5,179.2	22.5	18.3	174.30	-87.4	76.6	878.6	841.4	37.19	23.628		
5,500.0	5,397.8	5,288.9	5,280.6	23.0	18.7	174.35	-100.2	79.1	916.4	878.5	37.99	24.124		
5,600.0	5,494.4	5,361.5	5,352.5	23.5	18.9	174.38	-110.2	81.1	955.2	916.7	38.48	24.822		
5,700.0	5,590.9	5,465.0	5,455.0	24.1	19.3	174.42	-124.2	83.7	993.9	954.6	39.30	25.289		

CC - Min centre to center distance or covergent point, SF - min separation factor, ES - min ellipse separation

Anticollision Report

Company:	NEW MEXICO	Local Co-ordinate Reference:	Well SILVER BAR 35-36 FED STATE COM 133H
Project:	(SP) EDDY	TVD Reference:	kb @ 3358.0usft
Reference Site:	SILVER BAR	MD Reference:	kb @ 3358.0usft
Site Error:	0.0 usft	North Reference:	Grid
Reference Well:	SILVER BAR 35-36 FED STATE COM 133H	Survey Calculation Method:	Minimum Curvature
Well Error:	0.0 usft	Output errors are at	2.00 sigma
Reference Wellbore	owb	Database:	Compass_17
Reference Design:	PWP0	Offset TVD Reference:	Offset Datum

Offset Design: SILVER BAR - XXXX SILVER BAR 35 FED ST COM 203H - OWB - PWP0														Offset Site Error:	0.0 usft		
Survey Program: 0-MWD+IFR1+MS														Offset Well Error:	0.0 usft		
Reference Offset														Rule Assigned:			
Measured Reference Depth (usft)	Vertical Depth (usft)	Measured Offset Depth (usft)	Vertical Depth (usft)	Semi Reference (usft)	Major Axis Offset (usft)	Highside Toolface (°)	Offset Wellbore Centre		Distance Between Centres (usft)	Between Ellipses (usft)	Minimum Separation (usft)	Separation Factor	Warning				
							+N/-S (usft)	+E/-W (usft)									
0.0	0.0	0.0	0.0	0.0	0.0	-179.42	-84.6	-0.8	89.1								
100.0	100.0	72.0	72.0	0.3	0.3	-179.42	-84.6	-0.8	84.6	84.1	0.51	166.228					
200.0	200.0	172.0	172.0	0.6	0.6	-179.42	-84.6	-0.8	84.6	83.4	1.23	69.026					
300.0	300.0	272.0	272.0	1.0	1.0	-179.42	-84.6	-0.8	84.6	82.7	1.94	43.555					
400.0	400.0	372.0	372.0	1.3	1.3	-179.42	-84.6	-0.8	84.6	82.0	2.66	31.815					
500.0	500.0	472.0	472.0	1.7	1.7	-179.42	-84.6	-0.8	84.6	81.2	3.38	25.060					
600.0	600.0	572.0	572.0	2.0	2.1	-179.42	-84.6	-0.8	84.6	80.5	4.09	20.672					
700.0	700.0	672.0	672.0	2.4	2.4	-179.42	-84.6	-0.8	84.6	79.8	4.81	17.591					
800.0	800.0	772.0	772.0	2.8	2.8	-179.42	-84.6	-0.8	84.6	79.1	5.53	15.309					
900.0	900.0	872.0	872.0	3.1	3.1	-179.42	-84.6	-0.8	84.6	78.4	6.24	13.552					
1,000.0	1,000.0	972.0	972.0	3.5	3.5	-179.42	-84.6	-0.8	84.6	77.7	6.96	12.156					
1,100.0	1,100.0	1,072.0	1,072.0	3.8	3.8	-179.42	-84.6	-0.8	84.6	76.9	7.68	11.021					
1,200.0	1,200.0	1,172.0	1,172.0	4.2	4.2	-179.42	-84.6	-0.8	84.6	76.2	8.40	10.080					
1,300.0	1,300.0	1,272.0	1,272.0	4.6	4.6	-179.42	-84.6	-0.8	84.6	75.5	9.11	9.287					
1,400.0	1,400.0	1,372.0	1,372.0	4.9	4.9	-179.42	-84.6	-0.8	84.6	74.8	9.83	8.609					
1,500.0	1,500.0	1,472.0	1,472.0	5.3	5.3	-179.42	-84.6	-0.8	84.6	74.1	10.55	8.024					
1,600.0	1,600.0	1,572.0	1,572.0	5.6	5.6	-179.42	-84.6	-0.8	84.6	73.4	11.26	7.513					
1,700.0	1,700.0	1,672.0	1,672.0	6.0	6.0	-179.42	-84.6	-0.8	84.6	72.6	11.98	7.064					
1,800.0	1,800.0	1,772.0	1,772.0	6.3	6.4	-179.42	-84.6	-0.8	84.6	71.9	12.70	6.665					
1,900.0	1,900.0	1,872.0	1,872.0	6.7	6.7	-179.42	-84.6	-0.8	84.6	71.2	13.41	6.309					
2,000.0	2,000.0	1,972.0	1,972.0	7.1	7.1	-179.42	-84.6	-0.8	84.6	70.5	14.13	5.989 CC, ES					
2,100.0	2,100.0	2,072.0	2,072.0	7.4	7.4	177.96	-84.6	-0.8	86.4	71.5	14.85	5.817 SF					
2,200.0	2,199.8	2,171.8	2,171.8	7.8	7.8	178.07	-84.6	-0.8	91.6	76.0	15.56	5.885					
2,300.0	2,299.5	2,271.5	2,271.5	8.1	8.1	178.24	-84.6	-0.8	100.3	84.0	16.28	6.162					
2,400.0	2,398.7	2,370.7	2,370.7	8.5	8.5	178.42	-84.6	-0.8	112.5	95.5	16.99	6.620					
2,500.0	2,497.5	2,469.5	2,469.5	8.9	8.9	178.61	-84.6	-0.8	128.1	110.4	17.70	7.237					
2,600.0	2,595.6	2,567.6	2,567.6	9.2	9.2	178.78	-84.6	-0.8	147.2	128.8	18.41	7.995					
2,700.0	2,693.1	2,665.1	2,665.1	9.6	9.6	178.93	-84.6	-0.8	169.7	150.6	19.11	8.878					
2,750.0	2,741.5	2,713.5	2,713.5	9.8	9.7	179.00	-84.6	-0.8	182.2	162.7	19.47	9.360					
2,800.0	2,789.8	2,761.8	2,761.8	10.0	9.9	179.07	-84.6	-0.8	195.1	175.3	19.82	9.848					
2,900.0	2,886.4	2,858.4	2,858.4	10.4	10.2	179.18	-84.6	-0.8	221.0	200.5	20.51	10.775					
3,000.0	2,982.9	2,954.9	2,954.9	10.9	10.6	179.26	-84.6	-0.8	246.9	225.7	21.21	11.639					
3,100.0	3,079.5	3,051.5	3,051.5	11.3	10.9	179.33	-84.6	-0.8	272.8	250.9	21.92	12.446					
3,200.0	3,176.1	3,148.1	3,148.1	11.7	11.3	179.39	-84.6	-0.8	298.7	276.0	22.62	13.202					
3,300.0	3,272.7	3,244.7	3,244.7	12.2	11.6	179.44	-84.6	-0.8	324.5	301.2	23.33	13.911					
3,400.0	3,369.3	3,341.3	3,341.3	12.6	12.0	179.48	-84.6	-0.8	350.4	326.4	24.04	14.577					
3,500.0	3,465.9	3,437.9	3,437.9	13.1	12.3	179.52	-84.6	-0.8	376.3	351.6	24.75	15.204					
3,600.0	3,562.5	3,534.5	3,534.5	13.6	12.7	179.55	-84.6	-0.8	402.2	376.7	25.46	15.795					
3,700.0	3,659.1	3,631.1	3,631.1	14.0	13.0	179.57	-84.6	-0.8	428.1	401.9	26.18	16.353					
3,800.0	3,755.7	3,727.7	3,727.7	14.5	13.4	179.60	-84.6	-0.8	454.0	427.1	26.89	16.880					
3,900.0	3,852.3	3,824.3	3,824.3	15.0	13.7	179.62	-84.6	-0.8	479.8	452.2	27.61	17.379					
4,000.0	3,948.9	3,920.9	3,920.9	15.5	14.1	179.64	-84.6	-0.8	505.7	477.4	28.33	17.852					
4,100.0	4,045.5	4,017.5	4,017.5	16.0	14.4	179.66	-84.6	-0.8	531.6	502.6	29.05	18.302					
4,200.0	4,142.1	4,114.1	4,114.1	16.5	14.7	179.67	-84.6	-0.8	557.5	527.7	29.77	18.729					
4,300.0	4,238.6	4,210.6	4,210.6	17.0	15.1	179.69	-84.6	-0.8	583.4	552.9	30.49	19.135					
4,400.0	4,335.2	4,307.2	4,307.2	17.5	15.4	179.70	-84.6	-0.8	609.2	578.0	31.21	19.522					
4,500.0	4,431.8	4,403.8	4,403.8	18.0	15.8	179.71	-84.6	-0.8	635.1	603.2	31.93	19.891					
4,600.0	4,528.4	4,500.4	4,500.4	18.5	16.1	179.72	-84.6	-0.8	661.0	628.4	32.65	20.243					
4,700.0	4,625.0	4,597.0	4,597.0	19.0	16.5	179.73	-84.6	-0.8	686.9	653.5	33.38	20.579					
4,800.0	4,721.6	4,693.6	4,693.6	19.5	16.8	179.74	-84.6	-0.8	712.8	678.7	34.10	20.901					
4,900.0	4,818.2	4,790.2	4,790.2	20.0	17.2	179.75	-84.6	-0.8	738.7	703.8	34.83	21.209					

CC - Min centre to center distance or convergent point, SF - min separation factor, ES - min ellipse separation

Anticollision Report

Company:	NEW MEXICO	Local Co-ordinate Reference:	Well SILVER BAR 35-36 FED STATE COM 133H
Project:	(SP) EDDY	TVD Reference:	kb @ 3358.0usft
Reference Site:	SILVER BAR	MD Reference:	kb @ 3358.0usft
Site Error:	0.0 usft	North Reference:	Grid
Reference Well:	SILVER BAR 35-36 FED STATE COM 133H	Survey Calculation Method:	Minimum Curvature
Well Error:	0.0 usft	Output errors are at	2.00 sigma
Reference Wellbore	owb	Database:	Compass_17
Reference Design:	PWP0	Offset TVD Reference:	Offset Datum

Offset Design: SILVER BAR - XXXX SILVER BAR 35 FED ST COM 203H - OWB - PWP0													Offset Site Error:	0.0 usft
Survey Program: 0-MWD+IFR1+MS													Offset Well Error:	0.0 usft
Measured Reference Depth (usft)	Vertical Depth (usft)	Measured Offset Depth (usft)	Vertical Offset Depth (usft)	Semi Reference (usft)	Major Axis Offset (usft)	Highside Toolface (°)	Offset Wellbore Centre		Rule Assigned: Distance		Minimum Separation (usft)	Separation Factor	Warning	
							+N/-S (usft)	+E/-W (usft)	Between Centres (usft)	Between Ellipses (usft)				
5,000.0	4,914.8	4,886.8	4,886.8	20.5	17.5	179.76	-84.6	-0.8	764.5	729.0	35.55	21.504		
5,100.0	5,011.4	4,983.4	4,983.4	21.0	17.9	179.77	-84.6	-0.8	790.4	754.1	36.28	21.787		
5,200.0	5,108.0	5,080.0	5,080.0	21.5	18.2	179.78	-84.6	-0.8	816.3	779.3	37.01	22.058		
5,300.0	5,204.6	5,176.6	5,176.6	22.0	18.6	179.78	-84.6	-0.8	842.2	804.4	37.73	22.319		
5,400.0	5,301.2	5,273.2	5,273.2	22.5	18.9	179.79	-84.6	-0.8	868.1	829.6	38.46	22.570		
5,500.0	5,397.8	5,369.8	5,369.8	23.0	19.2	179.80	-84.6	-0.8	893.9	854.8	39.19	22.811		
5,600.0	5,494.4	5,466.4	5,466.4	23.5	19.6	179.80	-84.6	-0.8	919.8	879.9	39.92	23.043		
5,700.0	5,590.9	5,562.9	5,562.9	24.1	19.9	179.81	-84.6	-0.8	945.7	905.1	40.65	23.266		
5,800.0	5,687.5	5,659.5	5,659.5	24.6	20.3	179.81	-84.6	-0.8	971.6	930.2	41.38	23.481		
5,900.0	5,784.1	5,756.1	5,756.1	25.1	20.6	179.82	-84.6	-0.8	997.5	955.4	42.11	23.689		

CC - Min centre to center distance or convergent point, SF - min separation factor, ES - min ellipse separation

Anticollision Report

Company:	NEW MEXICO	Local Co-ordinate Reference:	Well SILVER BAR 35-36 FED STATE COM 133H
Project:	(SP) EDDY	TVD Reference:	kb @ 3358.0usft
Reference Site:	SILVER BAR	MD Reference:	kb @ 3358.0usft
Site Error:	0.0 usft	North Reference:	Grid
Reference Well:	SILVER BAR 35-36 FED STATE COM 133H	Survey Calculation Method:	Minimum Curvature
Well Error:	0.0 usft	Output errors are at	2.00 sigma
Reference Wellbore	owb	Database:	Compass_17
Reference Design:	PWP0	Offset TVD Reference:	Offset Datum

Reference Depths are relative to kb @ 3358.0usft
 Offset Depths are relative to Offset Datum
 Central Meridian is 104° 20' 0.000 W

Coordinates are relative to: SILVER BAR 35-36 FED STATE COM 133H
 Coordinate System is US State Plane 1983, New Mexico Eastern Zone
 Grid Convergence at Surface is: 0.15°

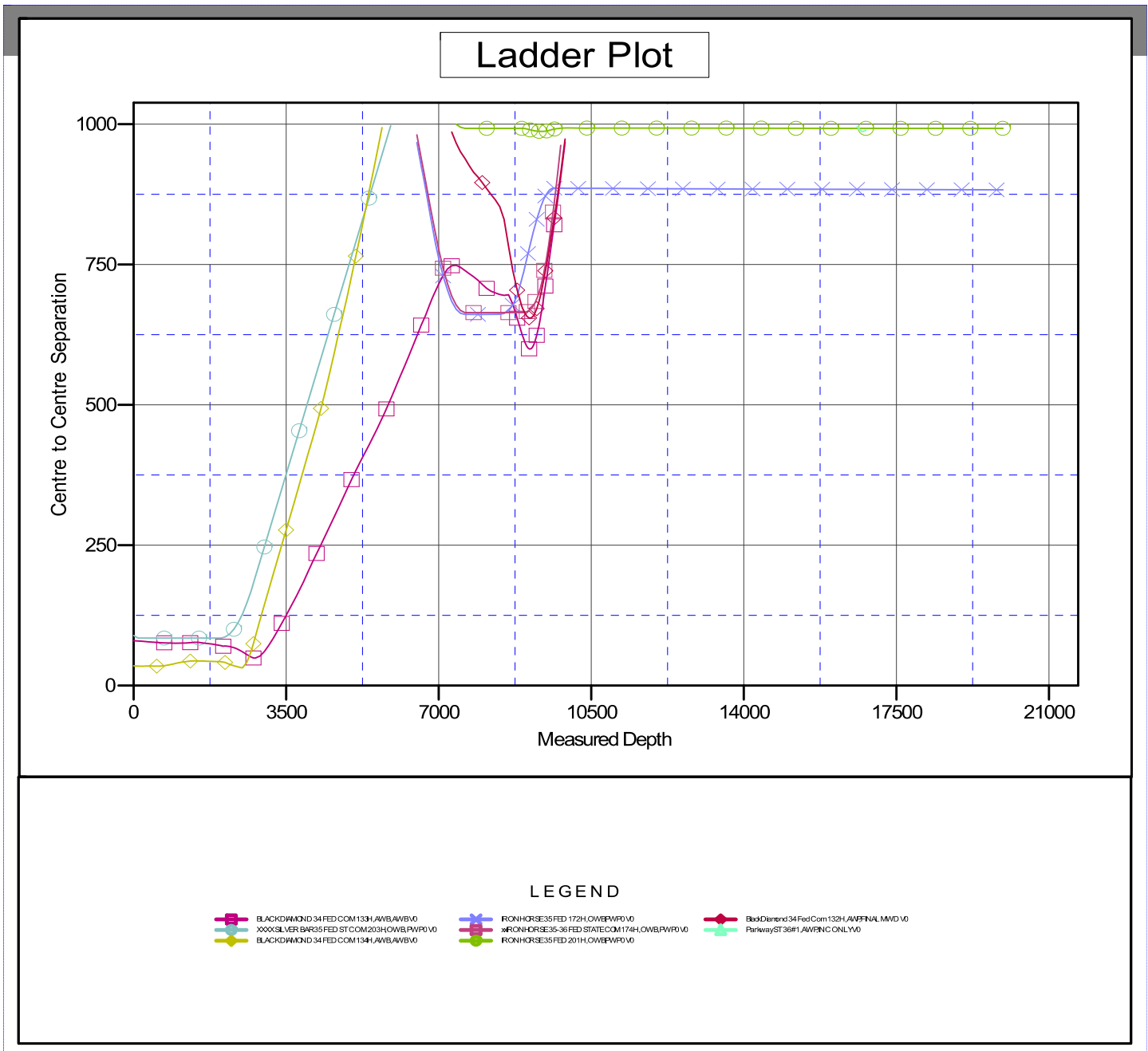

Anticollision Report

Company:	NEW MEXICO	Local Co-ordinate Reference:	Well SILVER BAR 35-36 FED STATE COM 133H
Project:	(SP) EDDY	TVD Reference:	kb @ 3358.0usft
Reference Site:	SILVER BAR	MD Reference:	kb @ 3358.0usft
Site Error:	0.0 usft	North Reference:	Grid
Reference Well:	SILVER BAR 35-36 FED STATE COM 133H	Survey Calculation Method:	Minimum Curvature
Well Error:	0.0 usft	Output errors are at	2.00 sigma
Reference Wellbore	owb	Database:	Compass_17
Reference Design:	PWP0	Offset TVD Reference:	Offset Datum

Reference Depths are relative to kb @ 3358.0usft
 Offset Depths are relative to Offset Datum
 Central Meridian is 104° 20' 0.000 W

Coordinates are relative to: SILVER BAR 35-36 FED STATE COM 133H
 Coordinate System is US State Plane 1983, New Mexico Eastern Zone
 Grid Convergence at Surface is: 0.15°

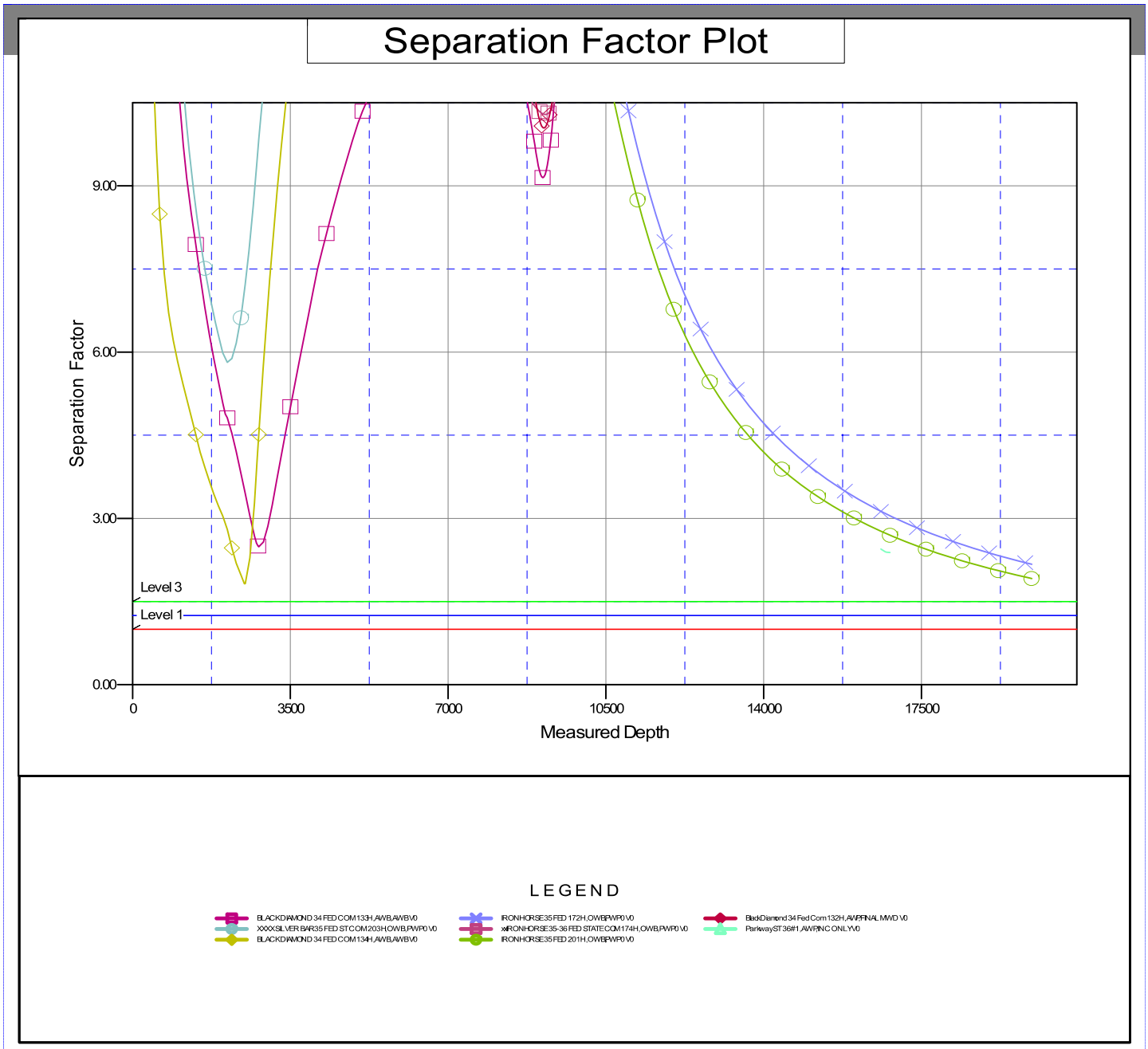

CC - Min centre to center distance or convergent point, SF - min separation factor, ES - min ellipse separation

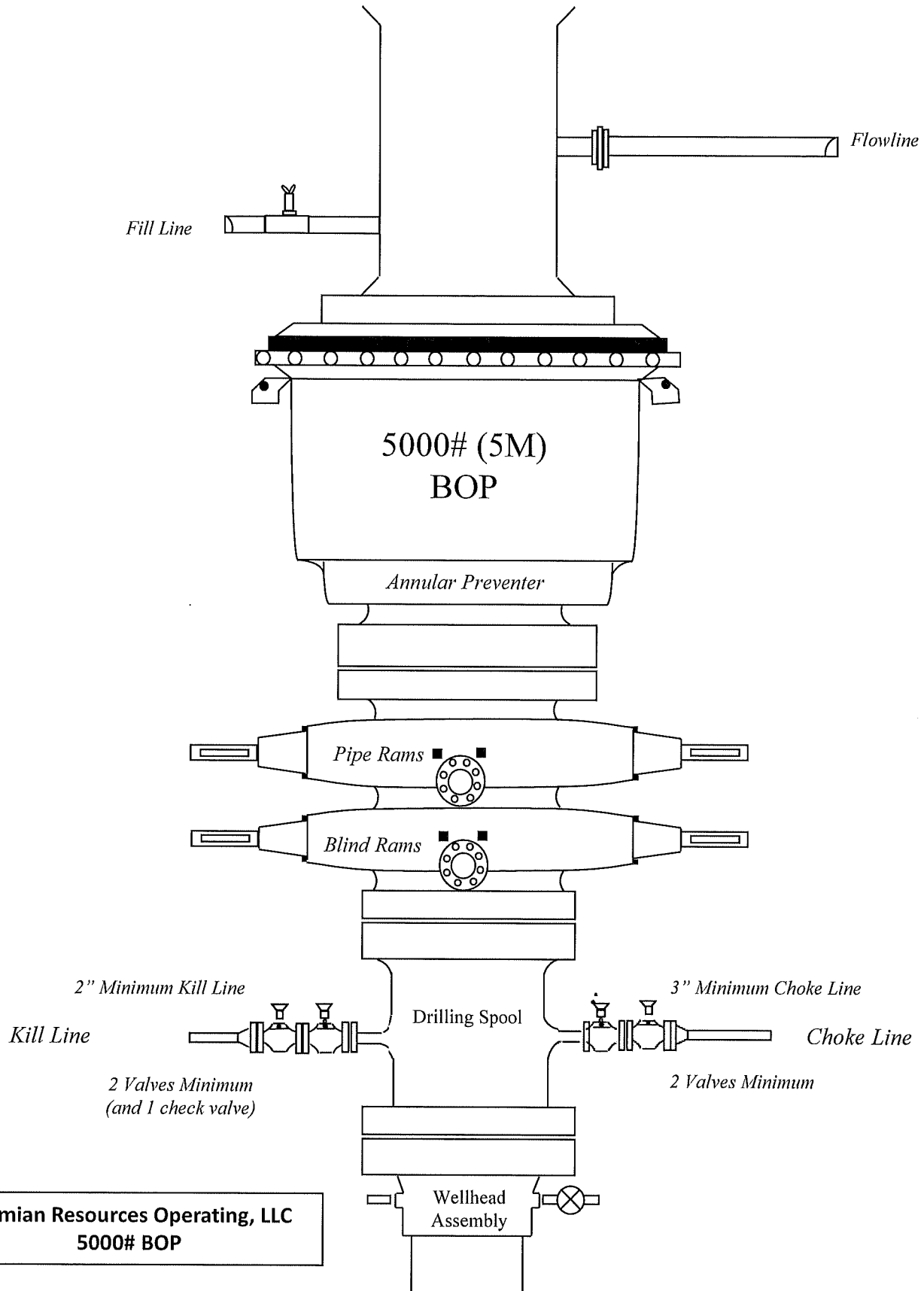

Bleed lines will discharge 100' from WH in non-H2S scenarios and 150' from WH in H2S scenarios.

Bleed lines will discharge 100' from WH in non-H2S scenarios and 150' from WH in H2S scenarios.

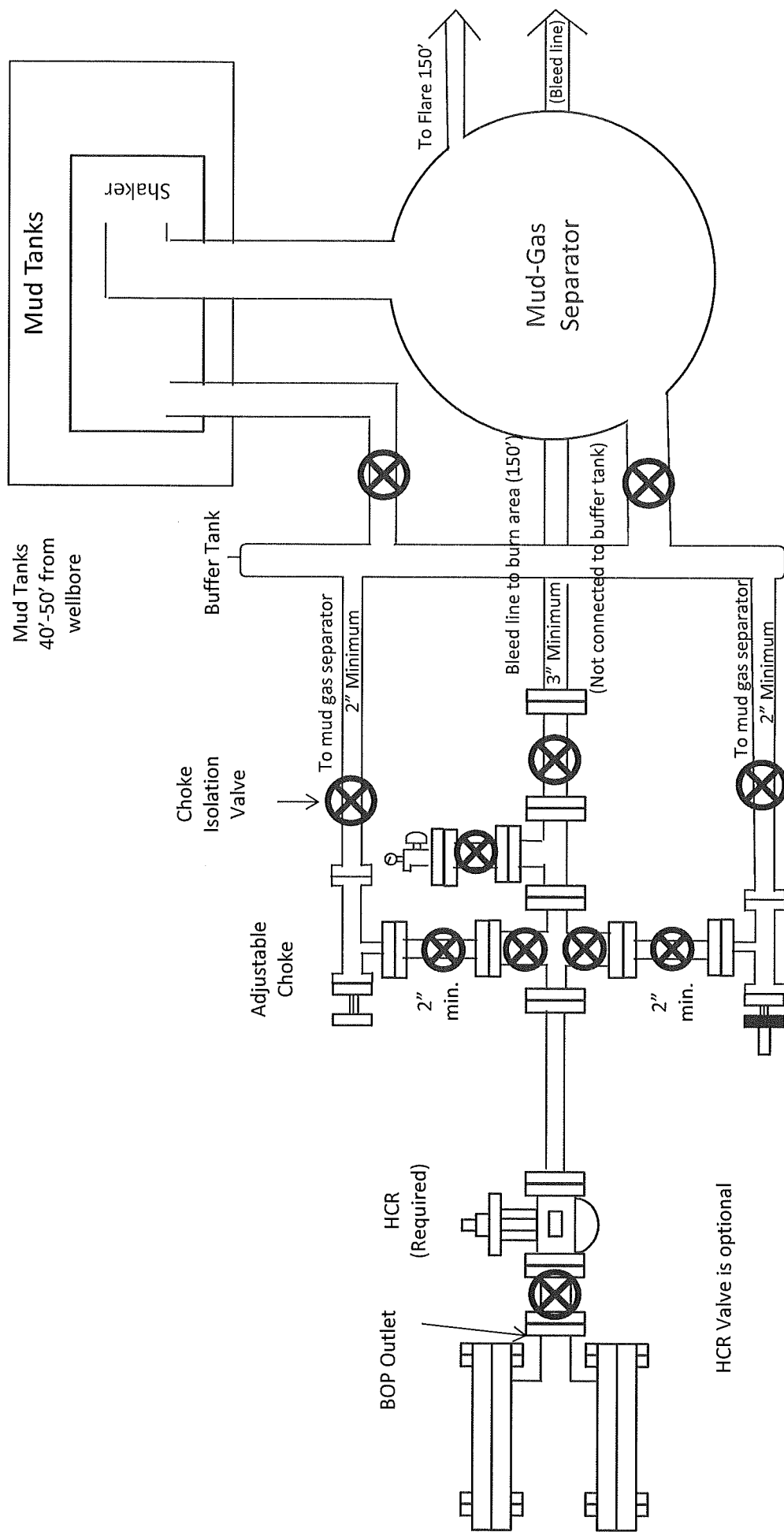

5M Choke Manifold Diagram
Permian Resources Operating, LLC

Drilling Operations Choke Manifold 5M Service

Permian Resources Multi-Well Pad Batch Drilling Procedure

Surface Casing - PR intends to Batch set all surface casing to a depth approved in the APD. Surface Holes will be batch drilled by a rig. Appropriate notifications will be made prior to spudding the well, running and cementing casing and prior to skidding to the rig to the next well on pad.

1. Drill Surface hole to Approved Depth with Rig and perform wellbore cleanup cycles. Trip out and rack back drilling BHA.
2. Run and land planned surface casing see Illustration 1-1 Below to depth approved in APD.
3. Set packoff and test to 5k psi
4. Offline Cement
5. Install wellhead with pressure gauge and nightcap. Nightcap is shown on final wellhead Stack up Illustration #2-2.
6. Skid Rig to adjacent well to drill Surface hole.
7. Surface casing test will be performed by the rig in order to allow ample time for Cement to develop 500psi compressive strength. Casing test to 0.22 psi/ft or 1500 psi whichever is greater - not to exceed 70% casing burst.

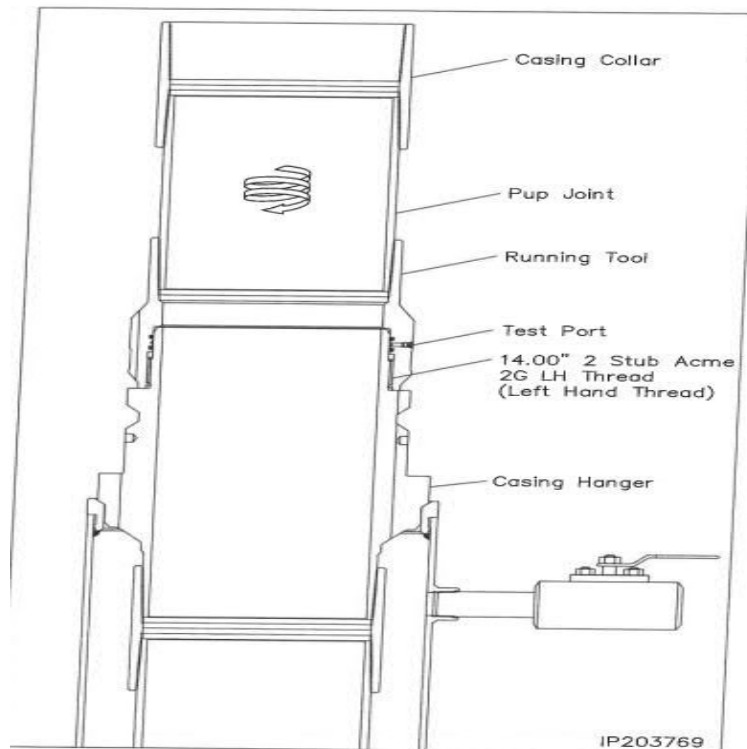

Illustration 1-1

Intermediate Casing – PR intends to Batch set all intermediate casing strings to a depth approved in the APD. Intermediate Holes will be batch drilled by the rig. Appropriate notifications will be made prior to testing BOPE, and prior to running/cementing all casing strings.

1. Rig will remove the nightcap and install and test BOPE.
2. Test Surface casing per COA WOC timing (.22 psi/ft or 1500 psi whichever is greater) - not to exceed 70% casing burst. Cement must have achieved 500psi compressive strength prior to test.
3. Install wear bushing then drill out surface casing shoe-track plus 20' and conduct FIT to minimum of the MW equivalent anticipated to control the formation pressure to the next casing point.
4. Drill Intermediate hole to approved casing point. Trip out of hole with BHA to run Casing.
5. Remove wear bushing then run and land Intermediate Casing with mandrel hanger in wellhead.
6. Cement casing to surface with floats holding.
7. Washout stack then run wash tool in wellhead and wash hanger and pack-off setting area.
8. Install pack-off and test void to 5,000 psi for 15 minutes. Nightcap shown on final wellhead stack up illustration 2-2 on page 3.
9. Test casing per COA WOC timing (.22 psi/ft or 1500 psi whichever is greater) - not to exceed 70% casing burst. Cement must have achieved 500psi compressive strength prior to test.
10. Install nightcap – skid rig to adjacent well to drill Intermediate hole.

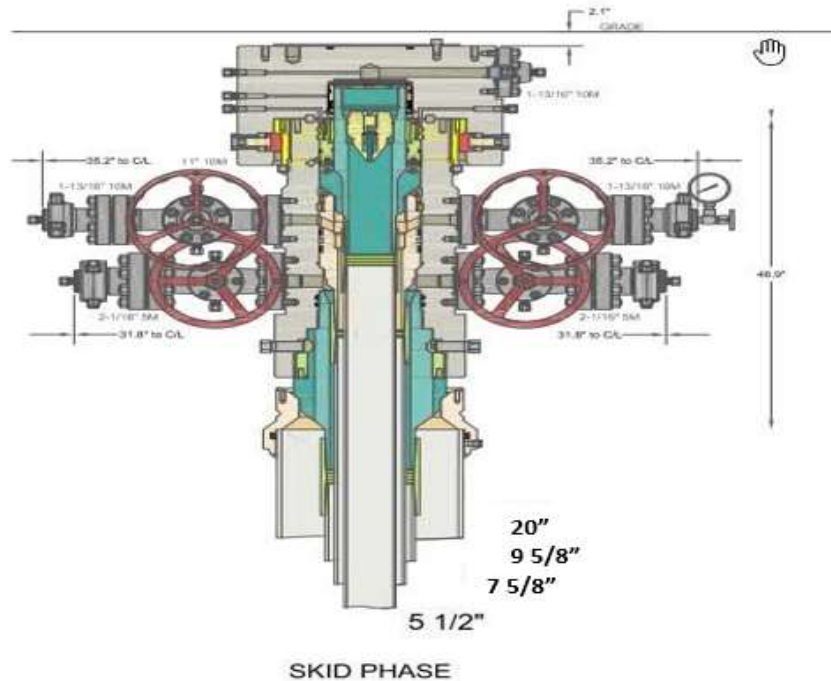

Illustration 2-2

Production Casing – PR intends to Batch set all Production casings with Rig. Appropriate notifications will be made prior Testing BOPE, and prior to running/cementing all casing strings.

1. Drilling Rig will remove the nightcap and install and test BOPE.
2. Install wear bushing then drill Intermediate shoe-track plus 20' and conduct FIT to minimum MW equivalent to control the formation pressure to TD of well.
3. Drill Vertical hole to KOP – Trip out for Curve BHA.
4. Drill Curve, landing in production interval – Trip for Lateral BHA.
5. Drill Lateral / Production hole to Permitted BHL, perform cleanup cycles and trip out to run Production Casing.
6. Remove wear bushing then run Production casing to TD landing casing mandrel in wellhead.
7. Cement Production string with floats holding.
8. Run in with wash tool and wash wellhead area – install pack-off and test void to 5,000psi for 15 minutes.
9. Install BPV in Production mandrel hanger – Nipple down BOPE and install nightcap.
10. Test nightcap void to 5,000 psi for 30 minutes per illustration 2-2
11. Skid rig to adjacent well on pad to drill production hole.

Permian Resources BOP Break Testing Variance Procedure

Subject: Request for a Variance Allowing break Testing of the Blowout Preventer Equipment (BOPE). Permian Resources requests a variance to ONLY test broken pressure seals on the BOPE and function test BOP when skidding a drilling rig between multiple wells on a pad.

Background

Title 43 CFR 3172, Drilling Operations, Sections 6.b.9.iv states that the BOP test must be performed whenever any seal subject to test pressure is broken. The current interpretation of the Bureau of Land Management (BLM) requires a complete BOP test and not just a test of the affected component. 43 CFR 3172.13, Variances from minimum standards states, "An operator may request the authorized officer to approve a variance from any of the minimum standards prescribed in [§§ 3172.6](#) through [3172.12](#). All such requests shall be submitted in writing to the appropriate authorized officer and provide information as to the circumstances which warrant approval of the variance(s) requested and the proposed alternative methods by which the related minimum standard(s) are to be satisfied. The authorized officer, after considering all relevant factors, if appropriate, may approve the requested variance(s) if it is determined that the proposed alternative(s) meet or exceed the objectives of the applicable minimum standard(s)." Permian Resources feels the break testing the BOPE is such a situation. Therefore, as per 43 CFR 3172.13, Permian Resources submits this request for the variance.

Supporting Documentation

The language used in 43 CFR 3172 became effective on December 19, 1988 and has remained the standard for regulating BLM onshore drilling operations for over 30 years. During this time, there have been significant changes in drilling technology. The BLM continues to use the variance request process to allow for the use of modern technology and acceptable engineering practices that have arisen since 43 CFR 3172 was originally released. The Permian Resources drilling rig fleet has many modern upgrades that allow the intact BOP stack to be moved between well slots on a multi-well pad, as well as, wellhead designs that incorporate quick connects facilitating release of the BOP from the wellhead without breaking any BOP stack components apart. These technologies have been used extensively offshore, and other regulators, API, and many operators around the world have endorsed break testing as safe and reliable.

Figure 1: Winch System attached to BOP Stack



Figure 2: BOP Winch System



American Petroleum Institute (API) standards, specification and recommended practices are considered the industry standard and are consistently utilized and referenced by the industry. 43 CFR 3172 recognizes API recommended Practices (RP) 53 in its original development. API Standard 53, Well Control Equipment Systems for Drilling Wells (Fifth Edition, December 2018, Annex C, Table C.4) recognizes break testing as an acceptable practice. Specifically, API Standard 53, Section 5.3.7.1 states "A pressure test of the pressure containing component shall be performed following the disconnection or repair, limited to the affected component." See Table C.4 below for reference.

62		API STANDARD 53	
Table C.4—Initial Pressure Testing, Surface BOP Stacks			
Component to be Pressure Tested	Pressure Test—Low Pressure ^{a,c} psig (MPa)	Pressure Test—High Pressure ^{a,c}	
		Change Out of Component, Elastomer, or Ring Gasket	No Change Out of Component, Elastomer, or Ring Gasket
Annular preventer ^b	250 to 350 (1.72 to 2.41)	RWP of annular preventer	MASP or 70% annular RWP, whichever is lower.
Fixed pipe, variable bore, blind, and BSR preventers ^{b,c}	250 to 350 (1.72 to 2.41)	RWP of ram preventer or wellhead system, whichever is lower	ITP
Choke and kill line and BOP side outlet valves below ram preventers (both sides)	250 to 350 (1.72 to 2.41)	RWP of side outlet valve or wellhead system, whichever is lower	ITP
Choke manifold—upstream of chokes ^a	250 to 350 (1.72 to 2.41)	RWP of ram preventers or wellhead system, whichever is lower	ITP
Choke manifold—downstream of chokes ^a	250 to 350 (1.72 to 2.41)	RWP of valve(s), line(s), or MASP for the well program, whichever is lower	
Kelly, kelly valves, drill pipe safety valves, IBOPs	250 to 350 (1.72 to 2.41)	MASP for the well program	

^a Pressure test evaluation periods shall be a minimum of five minutes. No visible leaks. The pressure shall remain stable during the evaluation period. The pressure shall not decrease below the intended test pressure.

^b Annular(s) and VBR(s) shall be pressure tested on the largest and smallest OD drill pipe to be used in well program.

^c For pad drilling operations, moving from one wellhead to another within the 21 days, pressure testing is required for pressure-containing and pressure-controlling connections when the integrity of a pressure seal is broken.

^d For surface offshore operations, the ram BOPs shall be pressure tested with the ram locks engaged and the closing and locking pressure vented during the initial test. For land operations, the ram BOPs shall be pressure tested with the ram locks engaged and the closing and locking pressure vented at commissioning and annually.

^e Adjustable chokes are not required to be full sealing devices. Pressure testing against a closed choke is not required.

The Bureau of Safety and Environmental Enforcement (BSEE), Department of Interior, has also utilized the API standards, specification and best practices in the development of its offshore oil and gas regulations and incorporates them by reference within its regulations.

Break testing has been approved by the BLM in the past with other operators based on the detailed information provided in this document.

Permian Resources feels break testing and our current procedures meet the intent of 43 CFR 3172 and often exceed it. There has been no evidence that break testing results in more components failing than seen on full BOP tests. Permian Resources internal standards require complete BOPE tests more often than that of 43 CFR 3172 (every 21 days). In addition to function testing the annular, pipe rams and blind rams after each BOP nipple up, Permian Resources performs a choke drill with the rig crew prior to drilling out every casing shoe. This is additional training for the rig crew that exceeds the requirements of 43 CFR 3172.

Procedures

- 1) Permian Resources will use this document for our break testing plan for New Mexico Delaware Basin. The summary below will be referenced in the APD or Sundry Notice and receive approval prior to implementing this variance.
- 2) Permian Resources will perform BOP break testing on multi-wells pads where multiple intermediate sections can be drilled and cased within the 21-day BOP test window.
 - a) A full BOP test will be conducted on the first well on the pad.
 - b) The first intermediate hole section drilled on the pad will be the deepest. All the remaining hole sections will be the same formation depth or shallower.
 - c) A full BOP test will be required if the intermediate hole section being drilled has a MASP over 5M.
 - d) A full BOP test will be required prior to drilling any production hole.
- 3) After performing a complete BOP test on the first well, the intermediate hole section will be drilled and cased, two breaks would be made on the BOP equipment.
 - a) Between the HCV valve and choke line connection
 - b) Between the BOP quick connect and the wellhead
- 4) The BOP is then lifted and removed from the wellhead by a hydraulic system.
- 5) After skidding to the next well, the BOP is moved to the wellhead by the same hydraulic system and installed.
- 6) The connections mentioned in 3a and 3b will then be reconnected.
- 7) Install test plug into the wellhead using test joint or drill pipe.
- 8) A shell test is performed against the upper pipe rams testing the two breaks.
- 9) The shell test will consist of a 250 psi low test and a high test to the value submitted in the APD or Sundry (e.g. 5,000 psi or 10,000psi).
- 10) Function tests will be performed on the following components: lower pipe rams, blind rams, and annular.
- 11) For a multi-well pad the same two breaks on the BOP would be made and on the next wells and steps 4 through 10 would be repeated.
- 12) A second break test would only be done if the intermediate hole section being drilled could not be completed within the 21 day BOP test window.

Note: Picture below highlights BOP components that will be tested during batch operations

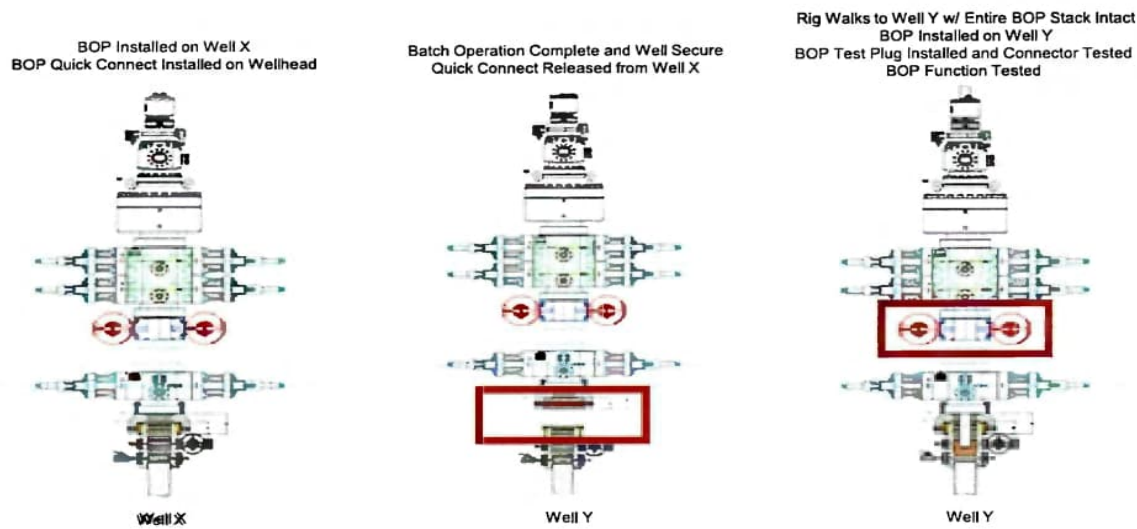

Summary

A variance is requested to ONLY test broken pressure seals on the BOP equipment when moving from wellhead to wellhead which is in compliance with API Standard 53. API Standard 53 states, that for pad drilling operations, moving from one wellhead to another within 21 days, pressure testing is required for pressure-containing and pressure-controlling connections when the integrity of a pressure seal is broken.

The BOP will be secured by a hydraulic carrier or cradle. The BLM will be contacted if a Well Control event occurs prior to the commencement of a BOPE Break Testing operation.

Based on public data and the supporting documentation submitted herein to the BLM, we will request permission to ONLY retest broken pressure seals if the following conditions are met:

- 1) After a full BOP test is conducted on the first well on the pad.
- 2) The first intermediate hole section drilled on the pad will be the deepest. All the remaining hole sections will be the same depth or shallower.
- 3) A full BOP test will be required if the intermediate hole section being drilled has a MASP over 5M.
- 4) A full BOP test will be required prior to drilling the production hole.

Only **ONE** test will occur during each break test procedure.

All valves in red including the upper pipe rams will be shut to test the broken connections.
** Each valve on choke manifold will alternate being tested against during each rig skid.

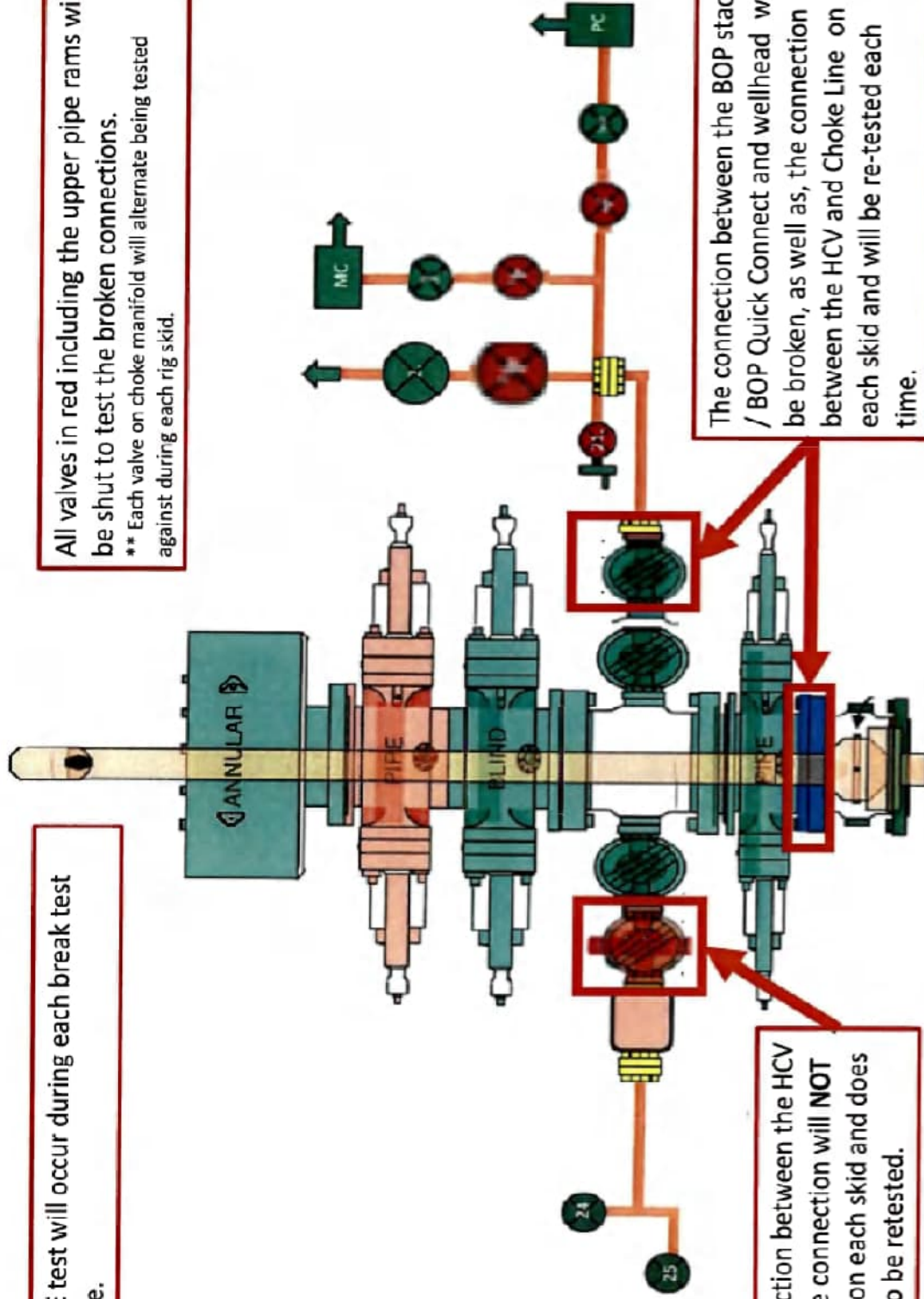

The connection between the HCV and kill line connection will **NOT** be broken on each skid and does not need to be retested.

The connection between the BOP stack / BOP Quick Connect and wellhead will be broken, as well as, the connection between the HCV and Choke Line on each skid and will be re-tested each time.

Permian Resources Offline Cementing Procedure Surface & Intermediate Casing

1. Drill hole to Total Depth with Rig and perform wellbore cleanup cycles.
2. Run and casing to Depth.
3. Land casing with mandrel.
4. Circulate 1.5 csg capacity.
5. Flow test – Confirm well is static and floats are holding.
6. Set Annular packoff and pressure test. Test to 5k.
7. Nipple down BOP and install cap flange.
8. Skid rig to next well on pad
9. Remove cap flange (confirm well is static before removal)
 - a) If well is not static use the casing outlet valves to kill well
 - b) Drillers method will be used in well control event
 - c) High pressure return line will be rigged up to lower casing valve and run to choke manifold to control annular pressure
 - d) Kill mud will be circulated once influx is circulated out of hole
 - e) Confirm well is static and remove cap flange to start offline cement operations
10. Install offline cement tool.
11. Rig up cementers.
12. Circulate bottoms up with cement truck
13. Commence planned cement job, take returns through the annulus wellhead valve
14. After plug is bumped confirm floats hold and well is static
15. Rig down cementers and equipment
16. Install night cap with pressure gauge to monitor.

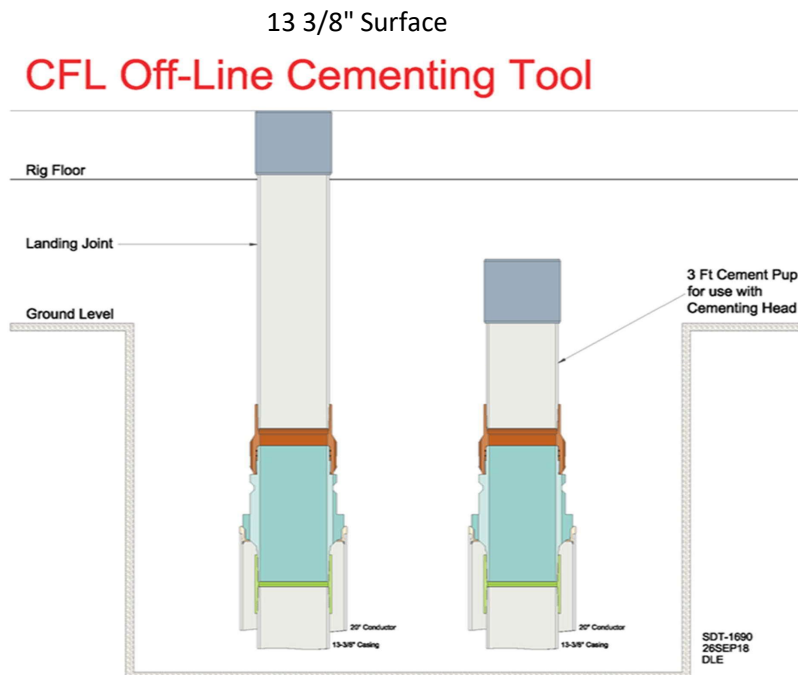

Intermediate

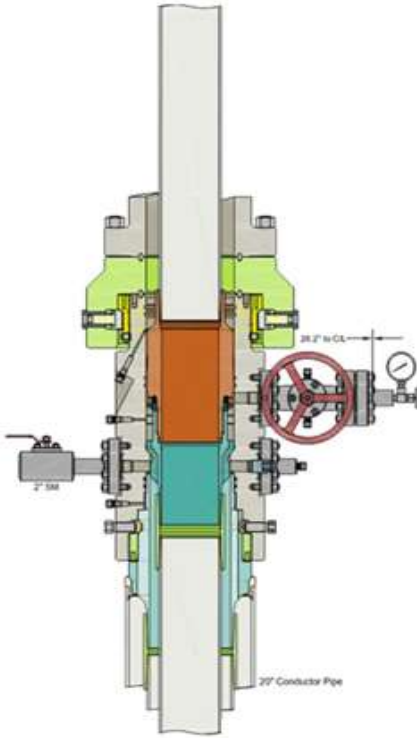

Run 7 5/8" Casing
Land Casing on 7 5/8" Mandrel Hanger
Cement 7 5/8" Casing
Retrieve Running Tool

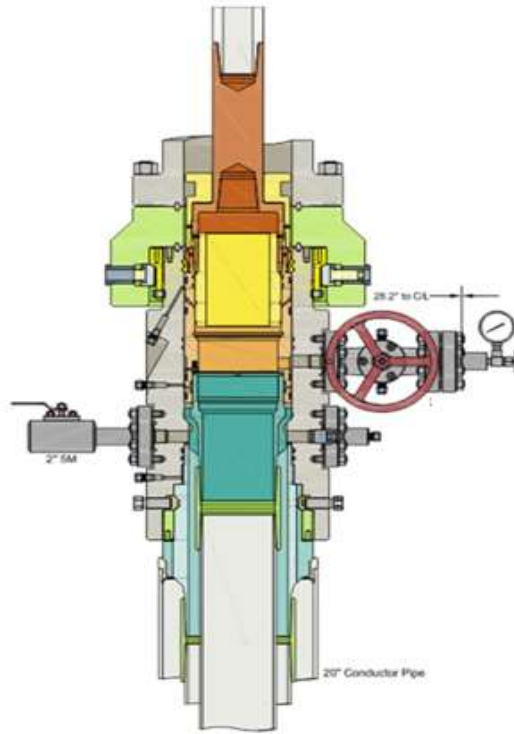

Run 9 5/8" Packoff
Test Upper and Lower Seals
Engage Lockring
Retrieve Running Tool

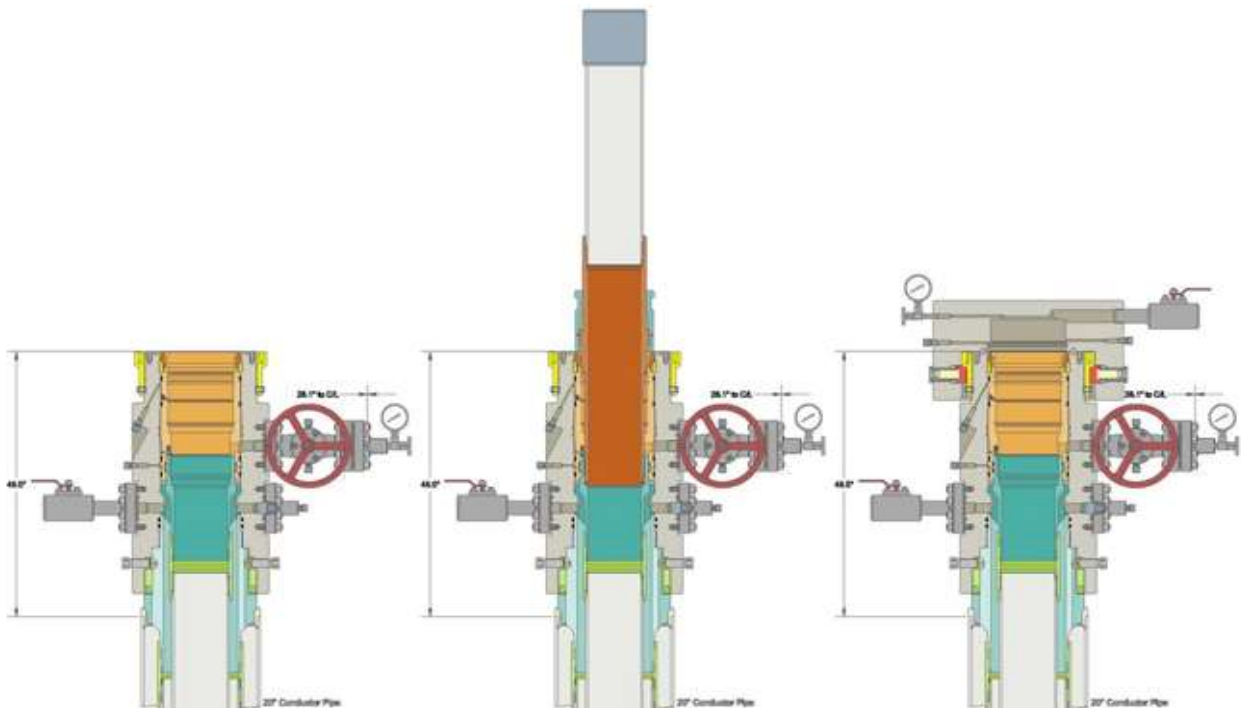



Variance Request – Bradenhead Squeeze (2nd Intermediate)

Permian Resources requests to pump a two-stage cement job on the 8-5/8” intermediate casing string with the first stage being pumped conventionally with the calculated top of cement at the Cherry Canyon and the second stage performed as a bradenhead squeeze with planned cement from the Brushy Canyon to surface. If cement is not visually confirmed to circulate to surface, the final cement top after the second stage job will be verified by Echo-meter. If necessary, a top out consisting of 1,500 sack of Class C cement + 3% Salt + Bentonite Gel (2.30 yld, 12.9 ppg) will be executed as a contingency. If cement is still unable to circulate to surface, another Echo-meter run will be performed for cement top verification.

Permian Resources will include the Echo-meter verified fluid top and the volume of displacement fluid above the cement slurry in the annulus in all post-drill sundries on wells utilizing this cement program.

Permian Resources will report to the BLM the volume of fluid (limited to 5 bbls) used to flush intermediate casing valves following backside cementing procedures.

Permian Resources requests to pump an Optional Lead if well conditions dictate in an attempt to bring cement inside the surface casing. If cement reaches the desired height, the BLM will be notified and the second stage bradenhead squeeze and subsequent TOC verification will be negated.

Permian Resources requests the option to conduct the bradenhead squeeze and TOC verification offline as per standard approval from BLM when unplanned remediation is needed and batch drilling is approved. In the event the bradenhead is conducted, we will ensure the first stage cement job is cemented properly and the well is static with floats holding and no pressure on the csg annulus as with all other casing strings where batch drilling operations occur before moving off the rig. The TA cap will also be installed per Cactus procedure and pressure inside the casing will be monitored via the valve on the TA cap as per standard batch drilling ops.



ContiTech Fluid Technology

ContiTech Oil & Marine Corp. # 11535 Brittmoores Park Dr., Houston, TX 77041-6916 USA		Packing list / Delivery note	
CONSIGNEE / Ship-to address: HELMERICH & PAYNE INT'L DRILLING CO ATTN: FLEX RIG WHSE - B-BAY 210 MAGNOLIA DRIVE GALENA PARK TX 77547		Document No. 71461553 Document Date 28.01.2022	Customer Number 11697 Customer VAT No. Supplier Number Purchase Order No. 740362040 Purchase Order Date 18.01.2022 Sales Order Number 1388153 Sales Order Date 18.01.2022
Buyer: HELMERICH & PAYNE INT'L DRILLING CO 1437 SOUTH BOULDER 74119 TULSA		Unloading Point RAN-No.	
Conditions Incoterms EXW Houston Ex Works		Page 1 of 2 Weights (Gross / Net) Total Gross Weight 2,507.000 LB Total Net Weight 2,507.000 LB	

Item	Material/Description	Quantity	Net Weight	Gross Weight
20	Buyer: Jack Peebles E-mail: Jackie.Peebles@hpinc.com Tel: 832-782-6000 Rig/Whse: HOW 00RECERTIFY Recert of HP Hoses Serial# 67094 Commodity Code: 3" X 35 FT 10K Choke & Kill Hoses API 16C End 1: 4 - 1/16" 10Kpsi API Spec 6A Type 6BX Flange End 2: 4 - 1/16" 10Kpsi API Spec 6A Type 6BX Flange c/w BX155 ring groove each end Standard: API Spec 16C - Monogrammed Working Pressure: 10,000psi Test Pressure: 15,000psi Inspection & Certification includes: External inspection of the hose & couplings Internal boroscopic inspection of hose liner Hydrostatic pressure test of hose assembly Repair of any external damage to hose body and end connections (limited to minor repairs). Clean & protect end connections Inspection Report Disposal of hose assembly if hose fails inspection and recertification process. Please Flush Hoses before sending them to our Facility.	1 PC	2,507.000 LB	2,507.000 LB

88000240
 (1106-01-0/01)
 2-9-22

ContiTech Rubber Industrial Kft.
 H-6728 Szeged Budapesti út 10.
 P. O. Box 152 Szeged H-6701
 Phone: (62)566-700, Fax: (62)566-713
 Tax Number: 11087209-2-06
 EU Community VAT: HU11087209
 Registration No.: Cg. 0609-002502
 Registry Court: Csongrád Megyei Cégbíróság

COMMERZBANK ZRT. (HUF)
 H-1054 Budapest, Széchenyi rakpart 8.
 H-1245 Budapest P.O. Box 1070
 Account No.: 14220108-26830003
 IBAN: HU83 1422 0108 2683 0003 0000 0000
 SWIFT: COBA HU HXXX

COMMERZBANK AG Hannover (EUR)
 30159 Hannover, Theaterstr. 11-12.
 Account No.: 3 066 156 00
 Sort Code: 250 400 66
 BIC: COBADEFF250
 IBAN: DE41250400660306615600

Record Rotary Hose sleeve number on the CBC Made Hose List!!!!!!!!!!!!!!!!!!!!!!!!!!!!!!!!!!!!



Hydrostatic Test Certificate

ContiTech

Certificate Number H100122	COM Order Reference 1388153	Customer Name & Address	
Customer Purchase Order No:	740362040	HELMERICH & PAYNE DRILLING CO 1434 SOUTH BOULDER AVE TULSA, OK 74119 USA	
Project:			
Test Center Address	Accepted by COM Inspection	Accepted by Client Inspection	
ContiTech Oil & Marine Corp. 11535 Brittmoore Park Drive Houston, TX 77041 USA	Signed: Gerson Mejia-Lazo Date: 02/09/22		

We certify that the goods detailed hereon have been inspected as described below by our Quality Management System, and to the best of our knowledge are found to conform the requirements of the above referenced purchase order as issued to ContiTech Oil & Marine Corporation.

Item	Part No.	Description	Qty	Serial Number	Work. Press. (psi)	Test Press. (psi)	Test Time (minutes)
------	----------	-------------	-----	---------------	--------------------	-------------------	---------------------

20	RECERTIFICATION	3" ID 10K Choke and Kill Hose x 35ft OAL	1	67094	10,000	15,000	60
----	-----------------	--	---	-------	--------	--------	----

Record Information	
Start Time	1/27/2022 13:21:21
End Time	1/27/2022 14:38:28
Interval	00:01:00
Number	78
MaxValue	15849
MinValue	-3
AvgValue	14240
RecordName	67094-sh
RecordNumber	199

Gauge Information	
Model	ADT680
SN	21817380014
Range	(0-40000)psi
Unit	psi

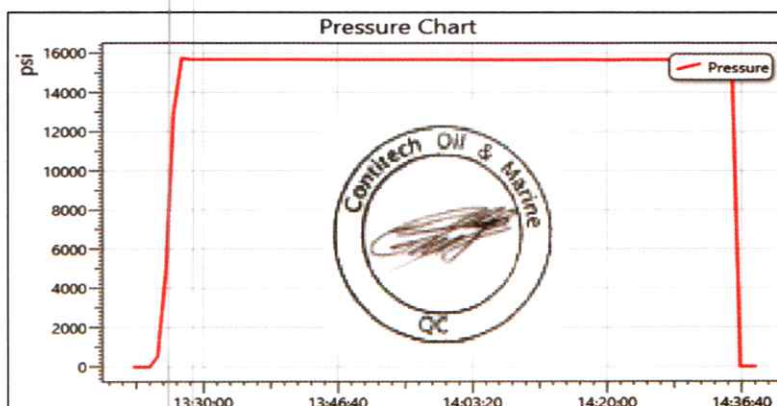

Sante Fe Main Office
Phone: (505) 476-3441

General Information
Phone: (505) 629-6116

Online Phone Directory
<https://www.emnrd.nm.gov/ocd/contact-us>

State of New Mexico
Energy, Minerals and Natural Resources
Oil Conservation Division
1220 S. St Francis Dr.
Santa Fe, NM 87505

CONDITIONS

Action 426032

CONDITIONS

Operator: Permian Resources Operating, LLC 300 N. Marienfeld St Ste 1000 Midland, TX 79701	OGRID: 372165
	Action Number: 426032
	Action Type: [C-103A] NOI Change of Plans (C-103A)

CONDITIONS

Created By	Condition	Condition Date
ward.rikala	Work was performed without OCD approval.	4/23/2026