

UNITED STATES
DEPARTMENT OF THE INTERIOR
BUREAU OF LAND MANAGEMENT

FORM APPROVED
OMB NO. 1004-0137
Expires: January 31, 2018

SUNDRY NOTICES AND REPORTS ON WELLS
Do not use this form for proposals to drill or to re-enter an abandoned well. Use form 3160-3 (APD) for such proposals.

5. Lease Serial No.
NMNM119280

6. If Indian, Allottee or Tribe Name

7. If Unit or CA/Agreement, Name and/or No.

SUBMIT IN TRIPLICATE - Other instructions on page 2

1. Type of Well
 Oil Well Gas Well Other

8. Well Name and No.
Multiple--See Attached

2. Name of Operator **COG OPERATING LLC** Contact: **JEANETTE BARRON**
E-Mail: **JBARRON@CONCHO.COM**

9. API Well No.
Multiple--See Attached

3a. Address **ONE CONCHO CENTER 600 W ILLINOIS AVENUE**
MIDLAND, TX 79701-4287 3b. Phone No. (include area code)
Ph: **575-748-6974**

10. Field and Pool or Exploratory Area
DOGIE DRAW-WOLFCAMP
WILDCAT BONE SPRING

4. Location of Well (Footage, Sec., T., R., M., or Survey Description)
Multiple--See Attached

11. County or Parish, State
LEA COUNTY, NM

12. CHECK THE APPROPRIATE BOX(ES) TO INDICATE NATURE OF NOTICE, REPORT, OR OTHER DATA

TYPE OF SUBMISSION	TYPE OF ACTION			
<input checked="" type="checkbox"/> Notice of Intent	<input type="checkbox"/> Acidize	<input type="checkbox"/> Deepen	<input type="checkbox"/> Production (Start/Resume)	<input type="checkbox"/> Water Shut-Off
<input type="checkbox"/> Subsequent Report	<input type="checkbox"/> Alter Casing	<input type="checkbox"/> Hydraulic Fracturing	<input type="checkbox"/> Reclamation	<input type="checkbox"/> Well Integrity
<input type="checkbox"/> Final Abandonment Notice	<input type="checkbox"/> Casing Repair	<input type="checkbox"/> New Construction	<input type="checkbox"/> Recomplete	<input checked="" type="checkbox"/> Other
	<input type="checkbox"/> Change Plans	<input type="checkbox"/> Plug and Abandon	<input type="checkbox"/> Temporarily Abandon	Production Facility Changes
	<input type="checkbox"/> Convert to Injection	<input type="checkbox"/> Plug Back	<input type="checkbox"/> Water Disposal	

13. Describe Proposed or Completed Operation: Clearly state all pertinent details, including estimated starting date of any proposed work and approximate duration thereof. If the proposal is to deepen directionally or recomplete horizontally, give subsurface locations and measured and true vertical depths of all pertinent markers and zones. Attach the Bond under which the work will be performed or provide the Bond No. on file with BLM/BIA. Required subsequent reports must be filed within 30 days following completion of the involved operations. If the operation results in a multiple completion or recompletion in a new interval, a Form 3160-4 must be filed once testing has been completed. Final Abandonment Notices must be filed only after all requirements, including reclamation, have been completed and the operator has determined that the site is ready for final inspection.

COG OPERATING LLC RESPECTFULLY REQUESTS DESIGNATION OF OIL FACILITY MEASUREMENT POINTS FOR SQUARE BILL FED 31P CTB

OIL FACILITY MEASUREMENT POINTS WILL BE #1 LACT #1814E10004 AND #2 TANK #109240916-1 AT THE BATTERY.

Square Bill Federal Com 1H 30-025-44046
Square Bill Federal Com 21Y 30-025-44397
Square Bill Federal Com 22H 30-025-44047
Square Bill Federal Com 23H 30-025-44048

14. I hereby certify that the foregoing is true and correct.

Electronic Submission #526219 verified by the BLM Well Information System

For COG OPERATING LLC, sent to the Hobbs

Committed to AFMSS for processing by DEBORAH MCKINNEY on 08/19/2020 (20DLM0436SE)

Name (Printed/Typed) **JEANETTE BARRON**

Title **REGULATORY TECHNICIAN**

Signature (Electronic Submission)

Date **08/18/2020**

THIS SPACE FOR FEDERAL OR STATE OFFICE USE

Approved By **ACCEPTED**

DEBORAH MCKINNEY
Title **LEGAL INSTRUMENTS EXAMINER**

Date **08/19/2020**

Conditions of approval, if any, are attached. Approval of this notice does not warrant or certify that the applicant holds legal or equitable title to those rights in the subject lease which would entitle the applicant to conduct operations thereon.

Office **Hobbs**

Title 18 U.S.C. Section 1001 and Title 43 U.S.C. Section 1212, make it a crime for any person knowingly and willfully to make to any department or agency of the United States any false, fictitious or fraudulent statements or representations as to any matter within its jurisdiction.

(Instructions on page 2)

**** BLM REVISED ** BLM REVISED ** BLM REVISED ** BLM REVISED ** BLM REVISED ****

Additional data for EC transaction #526219 that would not fit on the form

7. If Unit or CA/Agreement, Name and No., continued

NMNM137597
NMNM138981

Wells/Facilities, continued

Agreement	Lease	Well/Fac Name, Number	API Number	Location
NMNM137597	NMNM119280	SQUARE BILL FEDERAL COM	1H30-025-44046-00-S1	Sec 31 T25S R35E SESE 210FSL 957FEL 32.080203 N Lat, 103.401136 W Lon
NMNM138981	NMNM119280	SQUARE BILL FEDERAL COM	2180-025-44397-00-S1	Sec 31 T25S R35E SESE 240FSL 924FEL 32.080286 N Lat, 103.401028 W Lon
NMNM138981	NMNM119280	SQUARE BILL FEDERAL COM	2280-025-44047-00-S1	Sec 31 T25S R35E SESE 210FSL 990FEL 32.080204 N Lat, 103.401245 W Lon
NMNM138981	NMNM119280	SQUARE BILL FEDERAL COM	2380-025-44048-00-S1	Sec 31 T25S R35E SWSE 210FSL 1023FEL 32.080204 N Lat, 103.401344 W Lon
NMNM137597		FAC A SQUARE BILL		Sec 31 T25S R35E Mer NMP
NMNM138981		FAC A SQUARE BILL		Sec 31 T25S R35E Mer NMP

32. Additional remarks, continued

PLEASE SEE ATTACHED SITE FACILITY DIAGRAM

Revisions to Operator-Submitted EC Data for Sundry Notice #526219

	Operator Submitted	BLM Revised (AFMSS)
Sundry Type:	FAC NOI	FAC NOI
Lease:	NMNM119280	NMNM119280
Agreement:		NMNM137597 (NMNM137597) NMNM138981 (NMNM138981)
Operator:	COG OPERATING LLC 2208 W MAIN STREET ARTESIA, NM 88210 Ph: 575-748-6974	COG OPERATING LLC ONE CONCHO CENTER 600 W ILLINOIS AVENUE MIDLAND, TX 79701-4287 Ph: 432.685.4342
Admin Contact:	JEANETTE BARRON REGULATORY TECHNICIAN E-Mail: JBARRON@CONCHO.COM Ph: 575-748-6974	JEANETTE BARRON REGULATORY TECHNICIAN E-Mail: JBARRON@CONCHO.COM Ph: 575-748-6974
Tech Contact:	JEANETTE BARRON REGULATORY TECHNICIAN E-Mail: JBARRON@CONCHO.COM Ph: 575-748-6974	JEANETTE BARRON REGULATORY TECHNICIAN E-Mail: JBARRON@CONCHO.COM Ph: 575-748-6974
Location:		
State:	NM	NM
County:	LEA	LEA
Field/Pool:	WC-025G-08S2535340;BONE S	DOGIE DRAW-WOLFCAMP WILDCAT BONE SPRING
Well/Facility:	SQUARE BILL FEDERAL COM 1H	SQUARE BILL FEDERAL COM 1H Sec 31 T25S R35E SESE 210FSL 957FEL 32.080203 N Lat, 103.401136 W Lon SQUARE BILL FEDERAL COM 21Y Sec 31 T25S R35E SESE 240FSL 924FEL 32.080286 N Lat, 103.401028 W Lon SQUARE BILL FEDERAL COM 22H Sec 31 T25S R35E SESE 210FSL 990FEL 32.080204 N Lat, 103.401245 W Lon SQUARE BILL FEDERAL COM 23H Sec 31 T25S R35E SWSE 210FSL 1023FEL 32.080204 N Lat, 103.401344 W Lon FAC A SQUARE BILL Sec 31 T25S R35E Mer NMP FAC A SQUARE BILL Sec 31 T25S R35E Mer NMP

UNITED STATES
DEPARTMENT OF THE INTERIOR
BUREAU OF LAND MANAGEMENT

FORM APPROVED
OMB NO. 1004-0137
Expires: January 31, 2018

SUNDRY NOTICES AND REPORTS ON WELLS
Do not use this form for proposals to drill or to re-enter an abandoned well. Use form 3160-3 (APD) for such proposals.

5. Lease Serial No.
NMNM119280

6. If Indian, Allottee or Tribe Name

7. If Unit or CA/Agreement, Name and/or No.

SUBMIT IN TRIPLICATE - Other instructions on page 2

1. Type of Well <input checked="" type="checkbox"/> Oil Well <input type="checkbox"/> Gas Well <input type="checkbox"/> Other		8. Well Name and No. Multiple--See Attached
2. Name of Operator COG OPERATING LLC		9. API Well No. Multiple--See Attached
3a. Address ONE CONCHO CENTER 600 W ILLINOIS AVENUE MIDLAND, TX 79701-4287		10. Field and Pool or Exploratory Area DOGIE DRAW-WOLFCAMP WILDCAT BONE SPRING
3b. Phone No. (include area code) Ph: 575-748-6974		11. County or Parish, State LEA COUNTY, NM
4. Location of Well (Footage, Sec., T., R., M., or Survey Description) Multiple--See Attached		

12. CHECK THE APPROPRIATE BOX(ES) TO INDICATE NATURE OF NOTICE, REPORT, OR OTHER DATA

TYPE OF SUBMISSION	TYPE OF ACTION			
<input checked="" type="checkbox"/> Notice of Intent	<input type="checkbox"/> Acidize	<input type="checkbox"/> Deepen	<input type="checkbox"/> Production (Start/Resume)	<input type="checkbox"/> Water Shut-Off
<input type="checkbox"/> Subsequent Report	<input type="checkbox"/> Alter Casing	<input type="checkbox"/> Hydraulic Fracturing	<input type="checkbox"/> Reclamation	<input type="checkbox"/> Well Integrity
<input type="checkbox"/> Final Abandonment Notice	<input type="checkbox"/> Casing Repair	<input type="checkbox"/> New Construction	<input type="checkbox"/> Recomplete	<input checked="" type="checkbox"/> Other Production Facility Changes
	<input type="checkbox"/> Change Plans	<input type="checkbox"/> Plug and Abandon	<input type="checkbox"/> Temporarily Abandon	
	<input type="checkbox"/> Convert to Injection	<input type="checkbox"/> Plug Back	<input type="checkbox"/> Water Disposal	

13. Describe Proposed or Completed Operation: Clearly state all pertinent details, including estimated starting date of any proposed work and approximate duration thereof. If the proposal is to deepen directionally or recomplete horizontally, give subsurface locations and measured and true vertical depths of all pertinent markers and zones. Attach the Bond under which the work will be performed or provide the Bond No. on file with BLM/BIA. Required subsequent reports must be filed within 30 days following completion of the involved operations. If the operation results in a multiple completion or recompletion in a new interval, a Form 3160-4 must be filed once testing has been completed. Final Abandonment Notices must be filed only after all requirements, including reclamation, have been completed and the operator has determined that the site is ready for final inspection.

COG OPERATING LLC RESPECTFULLY REQUESTS DESIGNATION OF GAS FACILITY MEASUREMENT POINTS FOR SQUARE BILL FED 31P CTB

THE GAS FACILITY MEASUREMENT POINT IS GAS SALES METER # 161001136 MEETS API AND AGA STANDARDS AND WILL MEASURE AND BE CALIBRATED ACCORDING TO ALL FEDERAL REQUIREMENTS AND REGULATIONS.

PLEASE SEE ATTACHED SITE FACILITY DIAGRAM

- Square Bill Federal Com 1H 30-025-44046
- Square Bill Federal Com 21Y 30-025-44397
- Square Bill Federal Com 22H 30-025-44047
- Square Bill Federal Com 23H 30-025-44048

14. I hereby certify that the foregoing is true and correct. Electronic Submission #527573 verified by the BLM Well Information System For COG OPERATING LLC, sent to the Hobbs Committed to AFMSS for processing by PRISCILLA PEREZ on 08/27/2020 (20PP3458SE)	
Name (Printed/Typed) JEANETTE BARRON	Title REGULATORY TECHNICIAN
Signature (Electronic Submission)	Date 08/27/2020

THIS SPACE FOR FEDERAL OR STATE OFFICE USE

Approved By ACCEPTED	DEBORAH MCKINNEY Title LEGAL INSTRUMENTS EXAMINER	Date 09/01/2020
Conditions of approval, if any, are attached. Approval of this notice does not warrant or certify that the applicant holds legal or equitable title to those rights in the subject lease which would entitle the applicant to conduct operations thereon.		Office Hobbs

Title 18 U.S.C. Section 1001 and Title 43 U.S.C. Section 1212, make it a crime for any person knowingly and willfully to make to any department or agency of the United States any false, fictitious or fraudulent statements or representations as to any matter within its jurisdiction.

(Instructions on page 2)

**** BLM REVISED ** BLM REVISED ** BLM REVISED ** BLM REVISED ** BLM REVISED ****

Additional data for EC transaction #527573 that would not fit on the form

7. If Unit or CA/Agreement, Name and No., continued

NMNM137597
NMNM138981

Wells/Facilities, continued

Agreement	Lease	Well/Fac Name, Number	API Number	Location
NMNM137597	NMNM119280	SQUARE BILL FEDERAL COM	1H30-025-44046-00-S1	Sec 31 T25S R35E SESE 210FSL 957FEL 32.080203 N Lat, 103.401136 W Lon
NMNM138981	NMNM119280	SQUARE BILL FEDERAL COM	2180-025-44397-00-S1	Sec 31 T25S R35E SESE 240FSL 924FEL 32.080286 N Lat, 103.401028 W Lon
NMNM138981	NMNM119280	SQUARE BILL FEDERAL COM	2280-025-44047-00-S1	Sec 31 T25S R35E SESE 210FSL 990FEL 32.080204 N Lat, 103.401245 W Lon
NMNM138981	NMNM119280	SQUARE BILL FEDERAL COM	2380-025-44048-00-S1	Sec 31 T25S R35E SWSE 210FSL 1023FEL 32.080204 N Lat, 103.401344 W Lon

Revisions to Operator-Submitted EC Data for Sundry Notice #527573

	Operator Submitted	BLM Revised (AFMSS)
Sundry Type:	FAC NOI	FAC NOI
Lease:	NMNM119280	NMNM119280
Agreement:		NMNM137597 (NMNM137597) NMNM138981 (NMNM138981)
Operator:	COG OPERATING LLC 2208 W MAIN STREET ARTESIA, NM 88210 Ph: 575-748-6974	COG OPERATING LLC ONE CONCHO CENTER 600 W ILLINOIS AVENUE MIDLAND, TX 79701-4287 Ph: 432.685.4342
Admin Contact:	JEANETTE BARRON REGULATORY TECHNICIAN E-Mail: JBARRON@CONCHO.COM Ph: 575-748-6974	JEANETTE BARRON REGULATORY TECHNICIAN E-Mail: JBARRON@CONCHO.COM Ph: 575-748-6974
Tech Contact:	JEANETTE BARRON REGULATORY TECHNICIAN E-Mail: JBARRON@CONCHO.COM Ph: 575-748-6974	JEANETTE BARRON REGULATORY TECHNICIAN E-Mail: JBARRON@CONCHO.COM Ph: 575-748-6974
Location:		
State:	NM	NM
County:	LEA	LEA
Field/Pool:	WC-025 G-08 S253534O; BON	DOGIE DRAW-WOLFCAMP WILDCAT BONE SPRING
Well/Facility:	SQUARE BILL FEDERAL COM 1H	SQUARE BILL FEDERAL COM 1H Sec 31 T25S R35E SESE 210FSL 957FEL 32.080203 N Lat, 103.401136 W Lon SQUARE BILL FEDERAL COM 21Y Sec 31 T25S R35E SESE 240FSL 924FEL 32.080286 N Lat, 103.401028 W Lon SQUARE BILL FEDERAL COM 22H Sec 31 T25S R35E SESE 210FSL 990FEL 32.080204 N Lat, 103.401245 W Lon SQUARE BILL FEDERAL COM 23H Sec 31 T25S R35E SWSE 210FSL 1023FEL 32.080204 N Lat, 103.401344 W Lon

SQUARE BILL FEDERAL 31 P CTB
 SESE SECTION 31, T25S, R35E, UNIT P
 COORDS: 32.081409, -103.398822
 LEA COUNTY, NM

WELLS:
 SQUARE BILL FEDERAL COM #001H: 30-025-44046
 SQUARE BILL FEDERAL COM #021Y: 30-025-44397
 SQUARE BILL FEDERAL COM #022H: 30-025-44047
 SQUARE BILL FEDERAL COM #023H: 30-025-44048

GAS FMP METER
 Targa Gas Sales Line
 Meter (GS): #161001136

GAS METERS

#23H Gas Lift Meter: (L1): #39022498	Water Transfer Meter: (W4): #12141288815	#23H Meters: OIL (O1): #N400DE16000	#1H Meters: OIL (O3): #N400F216000
#22H Gas Lift Meter: (L2): #39022497	Booster Comp. Gas Meter: (BG): #39022434	#22H Meters: GAS (G4): #39022407	#21Y Meters: GAS (G2): #39022408
#1H Gas Lift Meter: (L3): # NO METER	Targa Buy Back Gas Meter: (BB): #161001137	OIL (O2): #N4006B16000	OIL (O4): #N400F416000
#21Y Gas Lift Meter: (L4): #39022500	Flare Gas Meter: (GF): #18905786	GAS (G3): #39022406	GAS (G1): #39022409
	VCU Gas Meter: (GC): #189068-86173		

ALLOCATION MTRS

Production Phase - Oil Tank #1

- Valve 1 open
- Valves 2, 3, and 4 closed
- Valves 5, 6, 7, and 8 open
- Valves 9, 10, 11, and 12 sealed closed
- Valve 13 open
- Valves 14, 15, and 16 closed

Sales Phase - Oil Tank #1

- Valve 1 sealed closed
- Valves 2, 3, or 4 open
- Valve 5 sealed closed
- Valves 6, 7, and 8 open
- Valve 9 open
- Valves 10, 11, and 12 sealed closed
- Valve 13 sealed closed
- Valves 14, 15, or 16 open

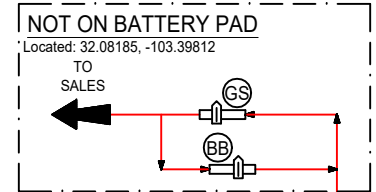
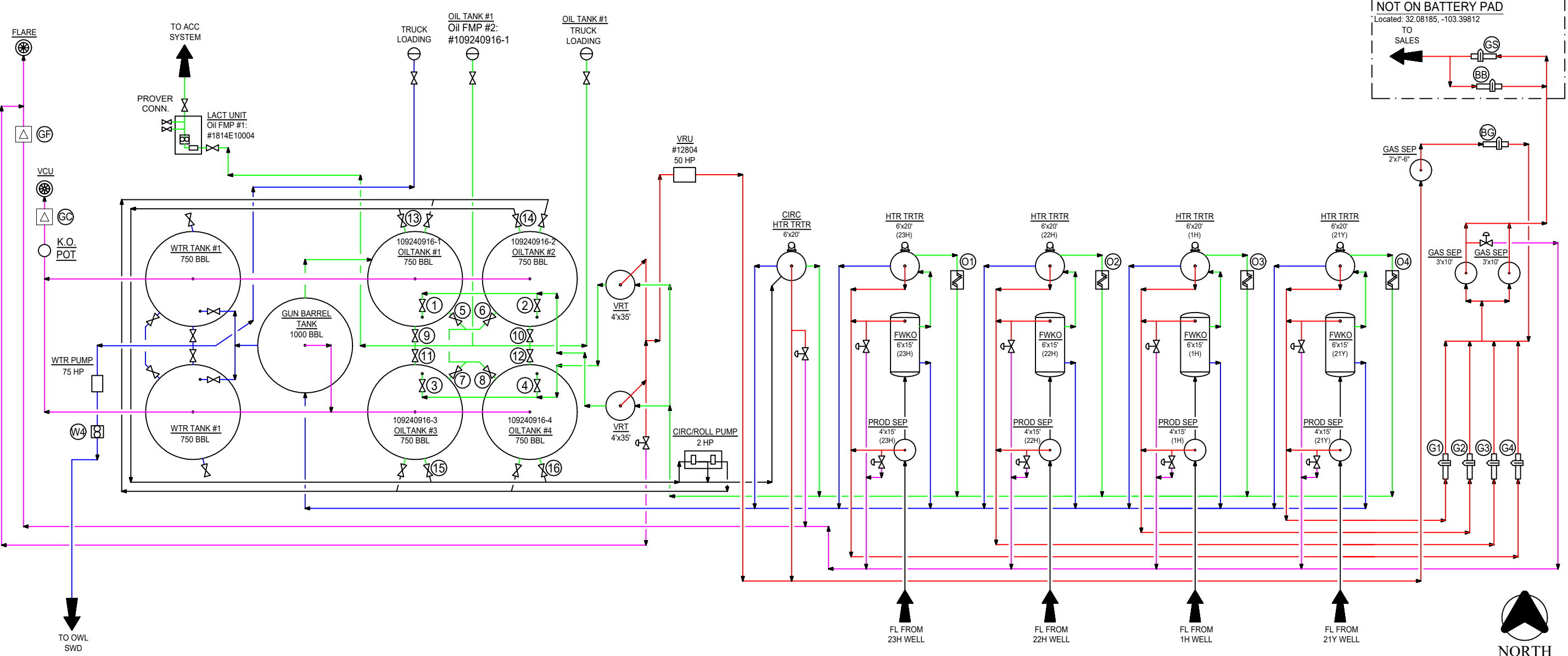

OCD - REC'D 9/8/2020

NOTES:
 Type of Lease: Federal
 Federal Lease #: NMNM119280
 CA #: NMNM138981, NMNM137597
 Property Code: 319617
 OGRID #: 229137

Ledger for Site Diagram

Produced Fluid: —
 Produced Oil: —
 Produced Gas: —
 Produced Water: —
 Flare/Vent: —

CONFIDENTIALITY NOTICE
 THIS DRAWING IS PROPERTY OF COG OPERATING LLC AND IS LENT TO THE BORROWER FOR CONFIDENTIAL USE ONLY AND IS SUBJECT TO RETURN UPON REQUEST AND SHALL NOT BE REPRODUCED, COPIED, LENT OR OTHERWISE DISPOSED OF DIRECTLY OR INDIRECTLY, NOR USED FOR ANY PURPOSE OTHER THAN THAT WHICH IT IS SPECIFICALLY FURNISHED.

REFERENCE DRAWINGS		REVISIONS				ENGINEERING RECORD	
NO.	TITLE	NO.	DATE	DESCRIPTION	BY	CHK.	APP.
A		09/06/18	09/06/18	ISSUED FOR REVIEW	JS	IV	
B		09/26/18	09/26/18	REVISED PER FIELD VERIFICATION	JS	DP	
C		08/17/20	08/17/20	REVISED PER FIELD RE-VERIFICATION	JS	JS	

COG OPERATING LLC SITE SECURITY PLANS LOCATED AT:		ENGINEERING RECORD	
NO.	DATE	BY	DATE
		DRN: JS	09/06/18
		DES:	
		CHK:	
		APP:	
		AFE NO:	
		FACIL ENGR:	
		OPER ENGR:	VARIABLES
		SCALE:	NONE

CONCHO

NORTHERN DELAWARE BASIN ASSET
 PRODUCTION FACILITIES
 SITE FACILITY DIAGRAM
 SQUARE BILL FED 31P CTB

LEA COUNTY NEW MEXICO

TWNSHIP/RANGE MULTIPLE DWG NO. D-1700-81-005 REV C