

HOBBS OCD

I&E - HOBBS

ATS-11-711

SEP 07 2011

UNITED STATES
DEPARTMENT OF THE INTERIOR
BUREAU OF LAND MANAGEMENT

Split Estate

FORM APPROVED
OMB No. 1004-0137
Expires July 31, 2010

RECEIVED

APPLICATION FOR PERMIT TO DRILL OR REENTER

5. Lease Serial No.
MLC031695B

6. If Indian, Allottee or Tribe Name

1a. Type of work: DRILL REENTER

7. If Unit or CA Agreement, Name and No.
Warren Unit

1b. Type of Well: Oil Well Gas Well Other Single Zone Multiple Zone

8. Lease Name and Well No.
Warren Unit B1-14 WF 394

2. Name of Operator
ConocoPhillips Company

9. API Well No.
30-025-40284

3a. Address 3300 N "A" St, Bldg 6 Midland, TX 79705

3b. Phone No. (include area code)
(432)688-6913

10. Field and Pool, or Exploratory
Warren; Blinebry-Tubb

4. Location of Well (Report location clearly and in accordance with any State requirements.)
At surface 1310 FNL 2361 FWL
At proposed prod. zone 1310 FNL 2361 FEL

11. Sec., T. R. M. or Blk. and Survey or Area
28,20S,38E

14. Distance in miles and direction from nearest town or post office*
7.6 miles north of Eunice, NM

12. County or Parish
Lea

13. State
NM

15. Distance from proposed* location to nearest property or lease line, ft. (Also to nearest drig. unit line, if any)

16. No. of acres in lease
5120

17. Spacing Unit dedicated to this well
40

18. Distance from proposed location* to nearest well, drilling, completed, applied for, on this lease, ft.
494 ft from Warren #394

19. Proposed Depth
7102'

20. BLM/BIA Bond No. on file
ES 0085

21. Elevations (Show whether DF, KDB, RT, GL, etc.)
3543' GL

22. Approximate date work will start*
10/05/2011

23. Estimated duration
10/14/2011

24. Attachments

The following, completed in accordance with the requirements of Onshore Oil and Gas Order No.1, must be attached to this form:

- 1. Well plat certified by a registered surveyor.
- 2. A Drilling Plan.
- 3. A Surface Use Plan (if the location is on National Forest System Lands, the SUPO must be filed with the appropriate Forest Service Office).
- 4. Bond to cover the operations unless covered by an existing bond on file (see Item 20 above).
- 5. Operator certification
- 6. Such other site specific information and/or plans as may be required by the BLM.

25. Signature *B. Maiorino* Name (Printed/Typed) Brian D Maiorino Date 06/29/2011

Title Regulatory Specialist

Approved by (Signature) /s/ Don Peterson Name (Printed/Typed) Office Date SEP 06 2011

Title /s/ Don Peterson Office

Application approval does not warrant or certify that the applicant holds legal or equitable title to those rights in the subject lease which would entitle the applicant to conduct operations thereon. Conditions of approval, if any, are attached.

Title 18 U.S.C. Section 1001 and Title 43 U.S.C. Section 1212, make it a crime for any person knowingly and willfully to make to any department or agency of the United States any false, fictitious or fraudulent statements or representations as to any matter within its jurisdiction.

(Continued on page 2)

Ka 09/13/11

*(Instructions on page 2)

Witness Surface Casing

LEA COUNTY CONTROLLED WATER BASIN

SEE ATTACHED FOR
CONDITIONS OF APPROVAL

Approval Subject to General Requirements
& Special Stipulations Attached

SEP 14 2011

HOBBS OCD

SEP 07 2011

RECEIVED

**SELF-CERTIFICATION STATEMENT
FROM LESSEE/OPERATOR**

SURFACE OWNER IDENTIFICATION

Federal or Indian Lease No. NM6C031695B
Well(s) Number and Location WARREN UNIT # 399
I, 20, 205, 38E 1330 FSL 1310 FEL

I hereby certify to the Authorized Officer of the Bureau of Land Management that I have reached one of the following agreements with the Surface Owner; or after failure of my good-faith effort to come to an agreement of any kind with the Surface Owner, I will provide a bond:

- 1) X I have a signed access agreement to enter the leased lands;
- 2) _____ I have a signed waiver from the surface owner;
- 3) _____ I have entered into an agreement regarding compensation to the surface owner for damages for loss of crops and tangible improvements.
- 4) _____ Because I have been unable to reach either 1), 2), or 3) with the surface owner, I will obtain a bond to cover loss of crops and damages to tangible improvements.

Surface owner information: (if available after diligent effort)

Surface Owner Name: Robert McCasland

Surface Owner Address: PO Box 206, Eunice, NM 88231

Surface Owner Phone Number: 575-394-3022

[Signature]
Signed this 28 - day of JUNE -, 20011.

Conoco Phillips Company
(Name of lessee/operator)

Warren Unit 394

Formation Tops and Planned Total Depth	
Formation Call Points	Top (ft MD)
Rustler	1427
Salado	1517
Tansill	2550
Yates	2702
Seven Rivers	2972
Queen	3523
Penrose	3675
Grayburg	3847
San Andres	4092
Glorieta	5375
Paddock	5515
Blinbry	5622
Tubb	6312
Drinkard	6630
Deepest Estimated Perforation	6902
Abo	6922
Total Depth (minimum)	7057
Total Depth (maximum)	7102

Casing Depths		
String	Minimum Depth	Maximum Depth
Surface Casing	1452	1497
Production Casing	7047	7092

Note: The Surface Casing and the Production Casing programs reflect an uncertainty of 45' in the setting depth for the shoe because that is the approximate length of a full joint of Range 3 casing. This range for the setting depth will allow us to drill the hole to fit the casing string based on how the tally comes out and will provide for the cementing head to be positioned at the rig floor for safety and efficiency in cementing operations. The casing will be set approximately 10 ft off bottom.

*TMM
5/15/2011*

Master Drilling Plan
 ConocoPhillips Company
Warren Unit
 June 28, 2011
 Warren Field
 Lea County, New Mexico

HOBBS OCD

SEP 07 2011

RECEIVED

1. Estimated tops of geological markers and estimated depths to water, oil, or gas formations:

The names, estimated tops, and thicknesses of the formations expected to be encountered, and the zones potentially containing usable water, oil, gas, or prospectively valuable deposits of other minerals, will be provided for each well on a separate document.

The ranges of depths for the formation tops, thicknesses, and planned Total Depths for the wells to be drilled under this Master Drilling Plan are presented in the table below.

The datum for these depths is RKB (which is 14' above Ground Level).

Formation Call	Formation Top FT MD	Thickness ft	Contents
Quaternary	Surface		Fresh Water
Rustler	1413 - 1543	65 - 90	Anhydrite
Salado (top of salt)	1493 - 1633	1033 - 1070	Salt
Tansill (base of salt)	2544 - 2703	135 - 154	Gas, Oil and Water
Yates	2698 - 2838	258 - 282	Gas, Oil and Water
Seven Rivers	2961 - 3100	548 - 617	Gas, Oil and Water
Queen	3521 - 3717	130 - 166	Gas, Oil and Water
Penrose	3675 - 3847	154 - 179	Gas, Oil and Water
Grayburg	3846 - 4001	226 - 260	Gas, Oil and Water
San Andres	4088 - 4232	1274 - 1333	Gas, Oil and Water
Glorieta	5375 - 5565	48 - 160	Gas, Oil and Water
Paddock	5515 - 5613	85 - 218	Gas, Oil and Water
Blinberry	5622 - 5801	658 - 740	Gas, Oil and Water
Tubb	6312 - 6468	304 - 357	Gas, Oil and Water
Drinkard	6630 - 6825	138 - 296	Gas, Oil and Water
Deepest estimated perforation	6902 - 7000		Deepest estimated perforation is ~ 20' above Top of Abo
Abo	6922 - 7020		TD is in the Abo to provide rathole below objective horizons
Total Depth (minimum)	7057 - 7155		155' below deepest estimated perforation
Total Depth (maximum)	7102 - 7200		200' below deepest estimated perforation

Protection of fresh water will be accomplished by setting the surface casing at least 25' into the Rustler Anhydrite formation, but above the top of the Salado Salt, and **cementing** the surface casing from the casing shoe to the **surface of ground** in accordance with the provisions of Onshore Oil and Gas Order No. 2 and New Mexico Oil Conservation Division Title 19.

Protection of oil and gas resources will be accomplished by setting the production casing approximately 10' off bottom and cementing it in accordance with the provisions Onshore Oil and Gas Order No. 2 and New Mexico Oil Conservation Division Title 19.

*see
ODA*

*TMM
8/15/2011*

2. Proposed casing program:

Type	Hole Size (in)	Interval MD RKB (ft)		OD (inches)	Wt (lb/ft)	Gr	Conn	Condition	Safety Factors Calculated per BLM Load Formulas		
		From	To						Burst	Collapse	Tension Dry/Buoyant
Cond	20"	0	~ 73' (~ 57' BGL)	16"	0 5" wall	B	Line Pipe	New	NA	NA	NA
Alt. Cond	20"	0	~ 73' (~ 57' BGL)	13-3/8"	48#	H-40	PE	New	NA	NA	NA
Surf	12-1/4"	0	1438' - 1613'	8-5/8"	24#	J-55	STC	New	4.22	1.92	6.30 / 7.24
Prod	7-7/8"	0	7057' - 7200'	5-1/2"	17#	L-80	LTC	New	2.41	1.68	2.76 / 3.25

See COA

The casing will be suitable for H₂S Service.

The surface casing will be set at least 25' into the Rustler Anhydrite formation, but above the top of the Salado Salt, and **cemented to the surface of ground** in accordance with the provisions of Onshore Oil and Gas Order No. 2 and New Mexico Oil Conservation Division Title 19.

The production casing will be set 155' to 200' below the deepest estimated perforation to provide rathole for the pumping completion and for the logs to get deep enough to log the interval of interest.

The perforations will be above the top of the Abo and the deepest estimated perforation is estimated to be approximately 20' above the top of the Abo.

The surface and production casing will be set approximately 10' off bottom and we will drill the hole to fit the casing string so that the cementing head is positioned at the floor for the cement job.

*TMM
8/15/2011*

Casing Design (Safety) Factors – BLM Criteria:

Joint Strength Design (Safety) Factor: SFt

$$SFt = Fj / Wt;$$

Where

- Fj is the rated pipe Joint Strength in pounds (lbs)
- Wt is the weight of the casing string in pounds (lbs)

The Minimum Acceptable Joint Strength Design (Safety) Factor SFt = 1.6 dry or 1.8 buoyant

Collapse Design (Safety) Factor: SFc

$$SFc = Pc / (MW \times .052 \times Ls)$$

Where

- Pc is the rated pipe Collapse Pressure in pounds per square inch (psi)
- MW is mud weight in pounds per gallon (ppg)
- Ls is the length of the string in feet (ft)

The Minimum Acceptable Collapse Design (Safety) Factor SFc = 1.125

Burst Design (Safety) Factor: SFb

$$SFb = Pi / BHP$$

Where

- Pi is the rated pipe Burst (Minimum Internal Yield) Pressure in pounds per square inch (psi)
- BHP is bottom hole pressure in pounds per square inch (psi)

The Minimum Acceptable Burst Design (Safety) Factor SFb = 1.0

Joint Strength Design (Safety) Factors – BLM Criteria

Surface Casing:

- SFj Dry = 244,000 lbs / (1613 ft x 24 lb/ft) = 244,000 lbs / 38,712 lbs = 6.30 Dry
- SFj Bouyant = 244,000 lbs / (1613 ft x 24 lb/ft) [1-(8.5/65.5)] = 244,000 lbs / 33,688 lbs = 7.24 Bouyant

Production Casing:

- SFj Dry = 338,000 lbs / (7200 ft x 17 lb/ft) = 338,000 lbs / 122,400 lbs = 2.76 Dry
- SFj Bouyant = 338,000 lbs / (7200 ft x 17 lb/ft) [1-(10.0/65.5)] = 338,000 lbs / 103,713 lbs = 3.25 Bouyant

Collapse Design (Safety) Factors – BLM Criteria

Surface Casing:

$$SFc = 1370 \text{ psi} / (8.5 \text{ ppg} \times .052 \times 1613 \text{ ft}) = 1370 \text{ psi} / 713 \text{ psi} = 1.92$$

Production Casing:

$$SFc = 6290 \text{ psi} / (10 \text{ ppg} \times .052 \times 7200 \text{ ft}) = 6290 \text{ psi} / 3744 \text{ psi} = 1.68$$

Burst Design (Safety) Factors – BLM Criteria

Surface Casing:

$$SFb = 2950 \text{ psi} / (8.33 \text{ ppg} \times .052 \times 1613 \text{ ft}) = 2950 \text{ psi} / 698 \text{ psi} = 4.22$$

Production Casing:

$$SFb = 7740 \text{ psi} / (8.5 \text{ ppg} \times .052 \times 7200 \text{ ft}) = 7740 \text{ psi} / 3201 \text{ psi} = 2.41 \text{ based on est. reservoir pressure data}$$

TMM
8/15/2011

Casing Design (Safety) Factors – Additional ConocoPhillips Criteria:

ConocoPhillips casing design policy establishes Corporate Minimum Design Factors (see table below) and requires that service life load cases be considered and provided for in the casing design.

ConocoPhillips Corporate Criteria for Minimum Design Factors

	Burst	Collapse	Axial
Casing Design Factors	1.15	1.05	1.4

Surface Casing:

The maximum internal (burst) load on the Surface Casing occurs when the surface casing is tested to 1500 psi. We will pressure up to 1600 psi and let the pressure settle for 1 minute after shutting down the pump. Then we will begin the 30 minute test period. Therefore the maximum pressure that the surface casing will be exposed to will be 1600 psi.

Surface Casing Burst Design Factor

$$DF \text{ Burst} = \text{Burst Rating} / \text{Maximum Pressure During Casing Pressure Test} = 2950 \text{ psi} / 1600 \text{ psi} = 1.84$$

The maximum collapse load on the Surface Casing occurs when we release the pressure after bumping the plug on the surface casing cement job.

Surface Casing Collapse Design Factor

$$DF \text{ Collapse} = \text{Collapse Rating} / (\text{Cement Column Hydrostatic Pressure} - \text{Displacement Fluid Hydrostatic Pressure})$$

$$DF \text{ Collapse} = 1370 \text{ psi} / \{[(350 \text{ ft} \times .052 \times 14.8 \text{ ppg}) + (1263 \text{ ft} \times .052 \times 13.6 \text{ ppg})] - (1613 \text{ ft} \times .052 \times 8.33 \text{ ppg})\}$$

$$DF \text{ Collapse} = 1370 \text{ psi} / 463 \text{ psi}$$

$$DF \text{ Collapse} = 2.95$$

The maximum axial load on the Surface Casing would occur if we were to get the surface casing stuck and pull on it to try to get it unstuck.

Surface Casing Axial (Tension) Maximum Allowable Hook Load Case:

$$\text{Maximum Allowable Hookload} = \text{Joint Strength Rating} / \text{Axial Design Factor}$$

$$\text{Maximum Allowable Hookload} = 244,000 / 1.4$$

$$\text{Maximum Allowable Hookload} = 174,286$$

$$\text{Overpull Margin} = \text{Maximum Allowable Hook Load} - \text{Air Wt of the String}$$

$$\text{Overpull Margin} = 174,286 \text{ lbs} - (1613' \times 24 \text{ lb/ft})$$

$$\text{Overpull Margin} = 174,286 \text{ lbs} - 38,712 \text{ lbs}$$

$$\text{Overpull Margin} = 135,574 \text{ lbs}$$

*TMA
8/11/2011*

Production Casing:

The maximum internal (burst) load would occur in the fracture stimulation either during fracture initiation or screen out.

The Maximum Allowable Working Pressure (MAWP) that we would impose in the fracture stimulation load case is the pressure that would result in a 1.15 burst design factor at surface.

For this well

MAWP for the Fracture Stimulation = Minimum Internal Yield / 1.15

MAWP for the Fracture Stimulation = 7740 psi / 1.15

MAWP for the Fracture Stimulation = 6730 psi

A pressure relief valve and pump truck kill settings will also be used to prevent overpressuring the production casing in the event of a screen out.

The maximum collapse load on the production casing occurs with the well pumped off on production.

DF Collapse = Collapse Rating / Bottom Hole Pressure

DF Collapse = 6290 psi / (8.5 ppg x .052 x 7200 ft) = 6290 psi / 3182 psi = 1.97

The maximum axial load on the Production Casing would occur if we were to get the Production Casing stuck and pull on it to try to get it unstuck.

Production Casing Axial (Tension) Maximum Hook Load Case:

Maximum Allowable Hookload = Joint Strength Rating / Axial Design Factor

Maximum Allowable Hookload = 338,000 lbs / 1.4

Maximum Allowable Hookload = 241,428 lbs

Overpull Margin = Maximum Allowable Hook Load - Air Wt of the String

Overpull Margin = 241,428 lbs - (7200' x 17 lb/ft)

Overpull Margin = 241,428 lbs - 122,400 lbs

Overpull Margin = 119,028 lbs

TMM
8/15/2011

3. Proposed cementing program:

16" or 13-3/8" Conductor:

Cement to surface with rat hole mix, ready mix or Class C Neat cement.

(Note: The gravel used in the cement is not to exceed 3/8" dia)

TOC at surface.

8-5/8" Surface Casing:

The intention for the cementing program for the Surface Casing is to:

- Place the Tail Slurry from the casing shoe to 350' above the casing shoe,
- Bring the Lead Slurry to surface.

Spacer: 20 bbls Fresh Water

Lead Slurry								
Volume (sx) & Recipe & Excess %	Top (ft MD)	Bottom (ft MD)	Length (ft)	Density (ppg)	Yield (cuft/sx)	Mix Wtr gal/sx	Compressive Strengths @ 90 deg F by UCA Method	
500-550 sx Class C + 4% bentonite + 2% CaCl2 + 0.125% Polyflake + 0.2% Antifoam Excess = 68%	Surface	1088 (min)	1088 (min)	13.6	1.71	8.923	Time 2 hrs 15 min	Strength 50 psi
		1263 (max)	1263 (max)				7 hrs 52 min 24 hrs 48 hrs 72 hrs	500 psi 1173 psi 1542 psi 1739 psi

Tail Slurry								
Volume (sx) & Recipe & Excess %	Top (ft MD)	Bottom (ft MD)	Length (ft)	Density (ppg)	Yield (cuft/sx)	Mix Wtr gal/sx	Compressive Strengths @ 90 deg F by UCA Method	
250 sx Class C + 1% CaCl2 Excess = 100%	1088 (min)	1438 (min)	350	14.8	1.34	6.371	Time 2 hrs 36 min	Strength 50 psi
		1263 (max)	1613 (max)				5 hrs 17 min 24 hrs 48 hrs 72 hrs	500 psi 2026 psi 2572 psi 2846 psi

Displacement: Fresh Water

The calculated average hole size for the surface hole for wells in the Warren Unit is 13.22" to 13.88" diameter based on volume of cement pumped and volume of cement returns to surface. Therefore this volume of cement should result in approximately 35 - 40 bbls of cement returns to surface.

Note: In accordance with the Pecos District Conditions of Approval, we will Wait on Cement (WOC) for a period of not less than 18 hrs after placement or until at least 500 psi compressive strength has been reached in both the Lead Slurry and Tail Slurry cements on the Surface Casing, whichever is greater.

*TMM
8/15/2011*

5-1/2" Production Casing Cementing Program:

The intention for the cementing program for the Production Casing is to:

- Place the Tail Slurry from the casing shoe to a point approximately 200' above the top of the Paddock,
- Bring the Lead Slurry to surface.

Spacer: 20 bbls Fresh Water.

Lead Slurry								
Volume (sx) & Recipe & Excess %	Top (ft MD)	Bottom (ft MD)	Length (ft)	Density (ppg)	Yield (cuft/sx)	Mix Wtr gal/sx	Compressive Strengths @ 113 deg F by Crush Method	
700 sx 50% Class C 50% POZ + 10% bentonite + 8 lb/sx Salt + 0.2% Fluid Loss Additive + 0.125% LCM if needed	Surface	5315 (min)	5315 (min)	11.8	2.55	14.88	Time 12 hrs 24 hrs 48 hrs 72 hrs	Strength 100 psi 200 psi 245 psi 310 psi
Excess = 40% or more if needed based on caliper if available. Estimated average hole size = 9"								
Note: This compressive strength data is from an old pilot test (20-Feb-2007) for this slurry and will be updated								

Tail Slurry								
Volume (sx) & Recipe & Excess %	Top (ft MD)	Bottom (ft MD)	Length (ft)	Density (ppg)	Yield (cuft/sx)	Mix Wtr gal/sx	Compressive Strengths @ 113 deg F by Crush Method	
350 sx 50% Class H 50% POZ + 2% Bentonite + 5% Salt + 0.4% Fluid Loss Additive + 0.2% Dispersant + Retarder if needed + Antifoam if needed	5315 (min)	7057 (min)	1742 (min)	14.2	1.32	6.20	Time 12 hrs 24 hrs 48 hrs 72 hrs	Strength 800 psi 1100 psi 1410 psi 1720 psi
Excess = 40% or more if needed based on caliper if available. Estimated average hole size = 8.2"								
Note: This compressive strength data is from an old pilot test (20-Feb-2007) for this slurry and will be updated								

Displacement: Fresh Water with approximately 250 ppm gluteraldehyde biocide.

Proposal for Option to Adjust Production Casing Cement Volumes:

The production casing cement volumes presented above are estimates based on data from previous wells. We will adjust these volumes based on the caliper log data for each well and our trends for amount of cement returns to surface and possibly reduce the excess % if we observe that we are getting excessive amounts of cement back to surface.

*Toman
8/15/2014*

4. Pressure Control Equipment:

The blowout preventer equipment (BOP) will conform to the requirements for a 2M System as described in Onshore Oil and Gas Order No. 2. However we will substitute higher rated BOP equipment and use additional equipment not required for a 2M System.

Our BOP equipment will be:

- Rotating Head
- Annular BOP, 11" 3M
- Blind Ram, 11" 3M
- Pipe Ram, 11" 3M

The blowout preventer equipment will be installed after running and cementing the surface casing and installing the wellhead on the surface casing.

Testing of the BOP equipment will be as follows:

- The appropriate BLM office shall be notified a minimum 4 hours in advance for a representative to witness the tests.
- The tests shall be done by an independent service company.
- The results of the test shall be reported to the appropriate BLM office.
- All tests are required to be recorded on a calibrated test chart.
- A copy of the BOP/BOPE test chart and a copy of independent service company test will be submitted to the appropriate BLM office.
- The BOP/BOPE test shall include a low pressure test from 250 to 300 psi. The test will be held for a minimum of 10 minutes if test is done with a test plug and 30 minutes without a test plug.
- Ram type preventers and associated equipment shall be tested to approved stack working pressure of 3000 psi. The Annular type preventer will be tested to 50 percent of rated working pressure, and therefore will be tested to 1500 psi. The above tests will be performed:
 - When initially installed
 - Whenever any seal subject to test pressure is broken
 - Following related repairs, and
 - At 30 day intervals
- Annular preventers, if used, will be functionally operated at least weekly.
- Pipe and Blind rams shall be activated each trip, but not more than once per day.
- All of the above described tests will be recorded in the drilling log.

A diagram of the proposed BOPs and choke manifold is attached.

The Working Pressure Requirement for the BOP equipment is calculated per Onshore Order 2 as follows:

- Expected bottom hole pressure = 8.5 ppg gradient
- Required Working Pressure for BOP Eqpt = $(8.5 \times .052 \times 7200) - (.22 \text{ psi/ft} \times 7200)$
- Required Working Pressure for BOP Eqpt = $3182 - (.22 \text{ psi/ft} \times 7200) = 1598 \text{ psi}$

T.W.M. 8/15/2011

5. Proposed Wellhead Program:

The wellhead equipment will be suitable for H₂S service.

We propose to use a Woodgroup S95 11" 5M casing head and T-S95 7-1/16" 10M Tubing Head; Material Class DD-NL, Temperature Class P.

We also propose that we have the option to use the following standard / conventional wellhead as an option:

- Casing Head 8-5/8" Slip on and Weld x 11" 5M Casing Head, API 6A, Material Class DD-NL, Temperature Class P, installed on 8-5/8" surface casing.
- Tubing Head. 11" 5M x 7-1/16" 10M Tubing Head, API 6A, Material Class DD-NL, Temperature Class P, installed after setting 5-1/2" production casing

6. Proposed Mud System

The mud systems that are proposed for use are as follows:

DEPTH	TYPE	Density ppg	FV sec/qt	API Fluid Loss cc/30 min	pH
0 – Surface Casing Point	Fresh Water or Fresh Water Native Mud	8.5 – 9.0	28 – 40	N.C.	N.C.
Surface Casing Point to TD	Brine (Saturated NaCl ₂)	10	29	N.C.	10 - 11
Conversion to Mud at TD	Brine Based Mud (NaCl ₂)	10	34 – 45	5 – 10	10 - 11

12-1/4" hole from surface of ground to surface casing point: The circulating media will be either a native mud or fresh water with high viscosity sweeps. The mud components will be:

- Fresh Water
- Bentonite (if needed)
- Lime
- Soda Ash
- Starch (if needed)
- Drilling Paper
- Other loss of circulation material if needed (nut plug or fibrous material)
- Soap sticks (if needed)

7-7/8" hole from the surface casing shoe to TD: The circulating media will be 10 ppg saturated NaCl₂ brine and will be converted to a mud with starch, attapulgite, lime, and asphalt for additional fluid loss control if needed upon reaching Total Depth (TD). The mud components will be:

- Brine (approximately 10 lb/gal density, saturated NaCl₂)
- Attapulgite
- Lime
- Starch
- Asphalt (if needed for additional fluid loss control)
- Drilling Paper, Walnut Hulls, and Fibrous LCM material such as BaroSeal if needed
- Soap Sticks if needed
- Lease crude oil or diesel with Pipe-Lax or EZ-Spot as a spotting fluid if needed in the event of differential sticking

Drilling mud containing H₂S shall be degassed in accordance with API RP-49, item 5.14. The gases shall be piped into the flare system.

Sufficient quantities of mud additives shall be maintained on location to scavenge and/or neutralize H₂S. We will inject into our flow stream while circulating from the corrosion trailer we have from Baroid ~10 gpd BaraScav L, SI-430, Baracor 100, and DA3-20 to scavenge H₂S and to protect the tubulars from corrosion. No barite or other weighting material will be on location.

TMM
6/15/2011

7. Logging, Coring, and Testing Program:

- a. No drill stem tests will be done
- b. No mud logging is planned, but might possibly be done if it is determined that this data is needed;
- c. No whole cores are planned
- d. The open hole electrical logging program is planned to be as follows:
 - Total Depth to 2500': Resistivity, Density, and Gamma Ray.
 - Total Depth to surface Casing Shoe: Caliper
 - Total Depth to surface, Gamma Ray and Neutron
 - Formation pressure data (XPT) on electric line if needed (optional)
 - Rotary Sidewall Cores on electric line if needed (optional)
 - BHC or Dipole Sonic if needed (optional)
 - Spectral Gamma Ray if needed (optional)

8. Abnormal Pressures and Temperatures:

- We do not expect to encounter any abnormal pressures or abnormally pressured horizons.
- The expected Bottom Hole Temperature is 113 degrees F.
- Loss of circulation is a possibility in the horizons below the Top of Grayburg. We expect that normal Loss of Circulation Material will be successful in healing any such loss of circulation events. *See COA*
- The bottom hole pressure is expected to be 8.5 ppg gradient. The calculation of Required Working Pressure for the BOP Equipment is presented below:
 - Required Working Pressure for BOP Eqpt = $(8.5 \times .052 \times 7200) - (.22 \text{ psi/ft} \times 7200)$
 - Required Working Pressure for BOP Eqpt = $3182 - (.22 \text{ psi/ft} \times 7200) = 1598 \text{ psi}$
- The estimated H₂S concentrations and ROE calculations for the gas in the zones to be penetrated are presented in the table below for the various producing horizons in this area:

FORMATION / ZONE	H2S (PPM)	Gas Rate (MCFD)	ROE 100 PPM	ROE 500 PPM
Seven Rivers (Eumont)	30,000	100	200	92
San Andres	33,000	30	100	46
Yeso Group	1000	300	47	22

ConocoPhillips will comply with the provisions of Oil and Gas Order # 6, Hydrogen Sulfide Operations and will provide H₂S monitoring equipment which will be rigged up, tested, and operational prior to drilling out from surface casing.

All persons arriving on location will have H₂S certification & training that occurred within the last year.

Each occurrence of H₂S gas at surface is to be noted on the daily reports and any occurrence of H₂S in excess of 100 ppm will be reported to the authorized officer as soon as possible but no later than the next business day per the provisions of Oil and Gas Order # 6, Hydrogen Sulfide Operations.

ConocoPhillips will provide an H₂S Contingency Plan and will keep this plan updated and posted at the wellsite during drilling operations.

All equipment that has the potential to be exposed to H₂S will be suitable for H₂S service.

*TMM
8/15/2011*

9. Anticipated starting date and duration of operations:

Road and location construction will begin after the BLM and NMOCD have approved the APD and will take into account any closure stipulations that may be attached or specified in order to avoid operations in any closure period. Also, rig availability may impact our schedule. With consideration of these limiting factors, we would intend / plan to drill this well within two years after receiving approval of the APD.

Attachments:

- Attachment # 1..... Proposed Casing and Cementing Program
- Attachment # 2..... Diagram of Choke Manifold Equipment (Excerpted from 54 FR 39528, Sept 27, 1989)
- Attachment # 3..... BOP and Choke Manifold Schematic – 2M System (Figure 3-1, Appendix G, from BLM)
- Attachment # 4..... BOP and Choke Manifold Schematic – 2M System (Figure 3-1A, Appendix G, from BLM)

Contact Information:

Program prepared by:
Steven O. Moore
Staff Drilling Engineer, ConocoPhillips Company
Phone (832) 486-2459
Cell (281) 467-7596
Date: June 28, 2011

*TMM
8/15/2011*

Proposed Casing & Cementing Program

Datum: RKB (14' above ground level)

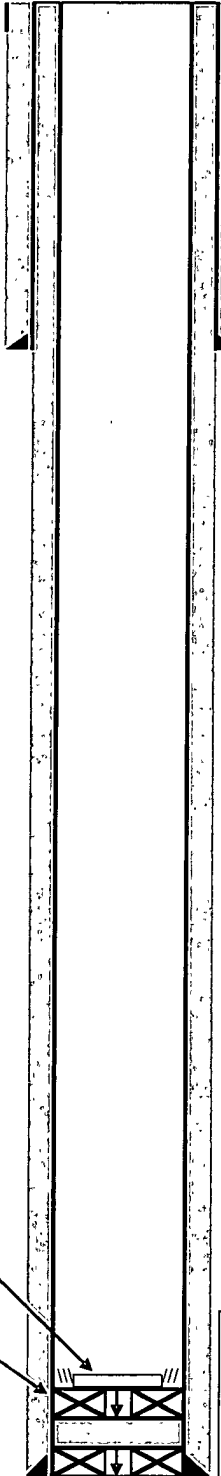

Conductor 13-3/8" 48# H-40 casing or 16" x 1/2" wall Grade B Line Pipe Set 30' to 85' below ground level (44' to 99' MD RKB) in 20" hole and cemented to surface

Surface Casing: 8-5/8" 24# J-55 ST&C set at least 25' into the Rustler formation and above the salt in 12-1/4" hole and cemented single-stage to surface .

Cement Wiper Plug

Float Shoe, one joint of casing, and Float Collar

Schematic prepared by:
Steven O. Moore, Staff Drilling Engineer
28-June-2011

Tom 8/15/2011

Production casing 5-1/2" 17# L-80 LT&C set 10' above TD in 7-7/8" hole and cemented single -stage to surface

Attachment # 2

Attachment I. Diagrams of Choke Manifold Equipment

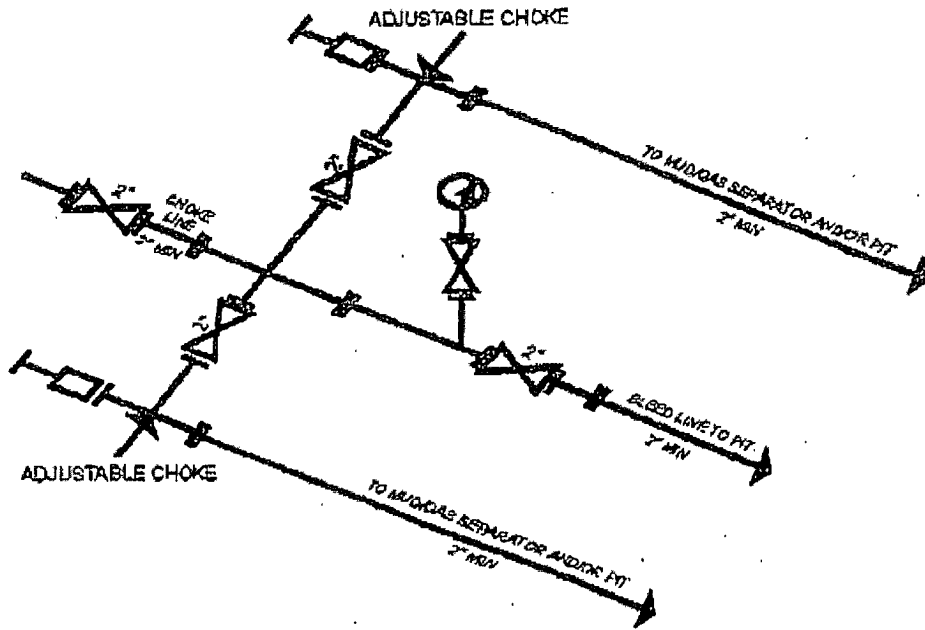

2M CHOKE MANIFOLD EQUIPMENT - CONFIGURATION OF CHOKES MAY VARY

Tuna
8/15/204

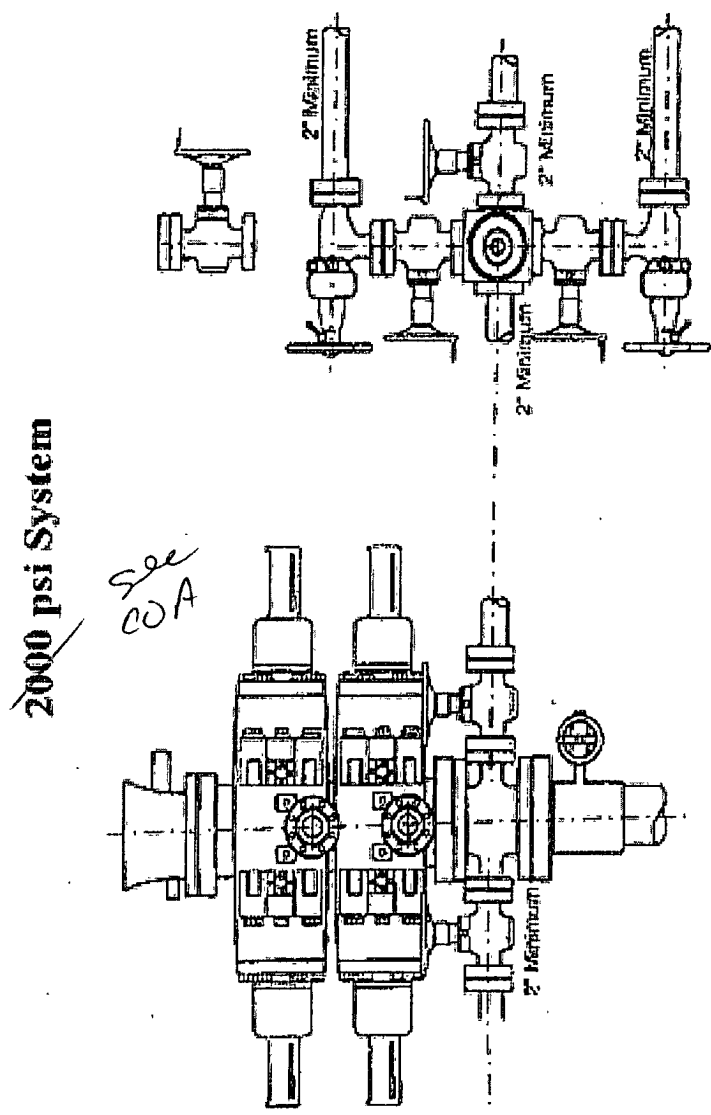

Figure 3-1

Appendix G

Tmu
5/15/2011

2000 psi System

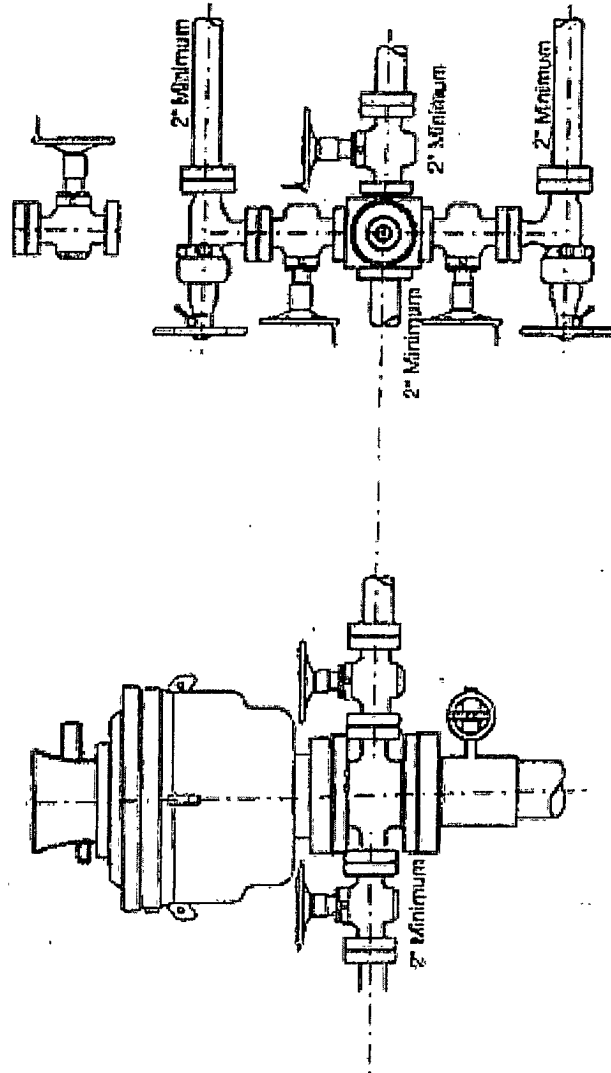

Figure 3-1A

Appendix G

Time 8/15/2014