

NO. OF COPIES RECEIVED	
DISTRIBUTION	
SANTA FE	
FILE	
U.S.G.S.	
LAND OFFICE	
OPERATOR	

5A. Indicate Type of Lease
STATE FEE

5. State Oil & Gas Lease No.
B-2516

APPLICATION FOR PERMIT TO DRILL, DEEPEN, OR PLUG BACK

1a. Type of Work DRILL <input checked="" type="checkbox"/> DEEPEN <input type="checkbox"/> PLUG BACK <input type="checkbox"/>		7. Unit Agreement Name	
b. Type of Well OIL WELL <input checked="" type="checkbox"/> GAS WELL <input type="checkbox"/> OTHER <input type="checkbox"/>		8. Farm or Lease Name Petrus AEO State	
2. Name of Operator Yates Petroleum Corporation		9. Well No. 1	
3. Address of Operator 105 South Fourth Street - Artesia, NM 88210		10. Field and Pool, or Wildcat Und. Sanmal-Queen	
4. Location of Well UNIT LETTER <u>B</u> LOCATED <u>990'</u> FEET FROM THE <u>North</u> LINE AND <u>1650</u> FEET FROM THE <u>East</u> LINE OF SEC. <u>11</u> TWP. <u>17S</u> RGE. <u>33E</u> NMPM		17. County Lea	
19. Proposed Depth 4000'		19A. Formation Queen	20. Rotary or C.T. Rotary
21. Elevations (Show whether DF, RT, etc.) 4158.2' GR	21A. Kind & Status Plug. Bond Blanket	21B. Drilling Contractor Undesignated	22. Approx. Date Work will start ASAP

23. PROPOSED CASING AND CEMENT PROGRAM

SIZE OF HOLE	SIZE OF CASING	WEIGHT PER FOOT	SETTING DEPTH	SACKS OF CEMENT	EST. TOP
12-1/4"	8-5/8"	24# J-55	Approx. 1550'	1000 sacks	Circulate
7-7/8"	5-1/2"	14# J-55	TD	300 sacks	Adequate cover

We propose to drill and test the Queen formation and intermediate zones. Approximately 1550' of surface casing will be set with cement circulated to surface to shut off gravel and cavings. If productive, 5-1/2" casing will be run and cemented with adequate cover, perforated and stimulated as needed for production.

MUD PROGRAM: Native mud to 1550'; brine water to TD

BOP PROGRAM: BOP's will be installed at the offset and tested daily

IN ABOVE SPACE DESCRIBE PROPOSED PROGRAM; IF PROPOSAL IS TO DEEPEN OR PLUG BACK, GIVE DATA ON PRESENT PRODUCTIVE ZONE AND PROPOSED NEW PRODUCTIVE ZONE. GIVE BLOWOUT PREVENTER PROGRAM, IF ANY.

I hereby certify that the information above is true and complete to the best of my knowledge and belief.

Signed *Jerry Sexton* Title Regulatory Agent Date August 3, 1987

(This space for State Use)

ORIGINAL SIGNED BY JERRY SEXTON

APPROVED BY DISTRICT 1 SUPERVISOR TITLE _____ DATE AUG 3 1987

CONDITIONS OF APPROVAL, IF ANY:

Permit Expires 6 Months From Approval
Date Unless Drilling Underway.

EXHIBIT B

BOP DIAGRAM

RATED 3000[#]

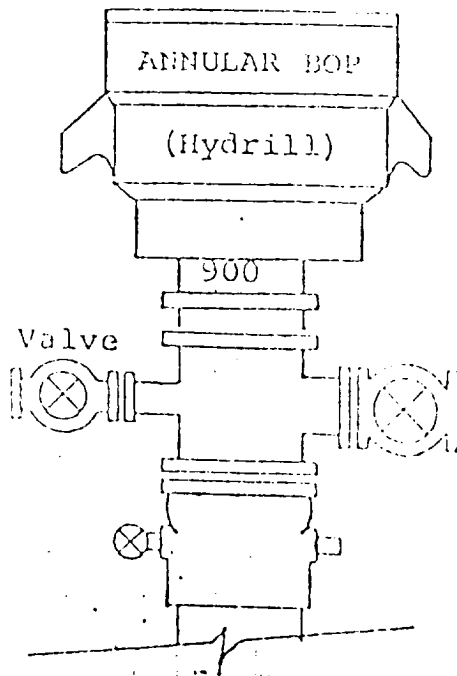

Bradenhead or Casinghead

HOBBS OFFICE
OCCO
AUG 3 1887
RECEIVED

12-11-15 1887