

NO. OF COPIES RECEIVED	
DISTRIBUTION	
SANTA FE	
FILE	
U.S.G.S.	
LAND OFFICE	
OPERATOR	

5A. Indicate Type of Lease  
STATE  FEE

5. State Oil & Gas Lease No.  
B-1961-1

APPLICATION FOR PERMIT TO DRILL, DEEPEN, OR PLUG BACK

1a. Type of Work DRILL <input checked="" type="checkbox"/> DEEPEN <input type="checkbox"/> PLUG BACK <input type="checkbox"/>		7. Unit Agreement Name	
b. Type of Well OIL WELL <input type="checkbox"/> GAS WELL <input type="checkbox"/> OTHER <input type="checkbox"/> SINGLE ZONE <input checked="" type="checkbox"/> MULTIPLE ZONE <input type="checkbox"/>		8. Farm or Lease Name New Mexico "J" State	
2. Name of Operator Texaco Inc.		9. Well No. 4	
3. Address of Operator P. O. Box 3109 Midland, Texas 79702		10. Field and Pool, or Wildcat Eunice Monument (G-SA)	
4. Location of Well UNIT LETTER <u>F</u> LOCATED <u>1980</u> FEET FROM THE <u>North</u> LINE AND <u>2310</u> FEET FROM THE <u>West</u> LINE OF SEC. <u>24</u> TWP. <u>19-S</u> RGE. <u>36-E</u> NMPW		12. County Lea	
19. Proposed Depth 4020'		19A. Formation Grayburg	20. History or C.T. Rotary
21. Elevations (show whether DF, KI, etc.) 3711' Ground	21A. Kind & Status Plug Bond	21B. Drilling Contractor	22. Approx. Date Work will start 7-12-84

23.

PROPOSED CASING AND CEMENT PROGRAM

SIZE OF HOLE	SIZE OF CASING	WEIGHT PER FOOT	SETTING DEPTH	SACKS OF CEMENT	EST. TOP
12 1/4"	8 5/8"	24# K-55, STC	400'	250	Circulate
7 7/8"	5 1/2"	15.5# K-55, LTC	4020'	1225	Circulate

SURFACE CASING: 150 sxs Lite Weight w/2% CaCl and 1/4# Flocele/sx (13.0 ppg., 1.63ft/sx) followed by 100 sxs Class "H" w/2% CaCl (15.6 ppg., 1.18ft/sx).

PRODUCTION CASING: 1st Stage: 150 sxs Lite Weight w/1/4# Flocele/sx (12.4 ppg., 2.00ft/sx) followed by 175 sxs Class "H" w/1/4# Flocele/sx (15.6 ppg., 1.18ft/sx).

2nd Stage: Cement through DV tool @ 2500' w/900 sxs Lite Weight w/15# salt and 1/4# Flocele/sx (12.7 ppg., 2.10ft/sx).

APPROVAL VALID FOR 180 DAYS  
PERMIT EXPIRES 11/27/85  
UNLESS DRILLING UNDERWAY

IN ABOVE SPACE DESCRIBE PROPOSED PROGRAM; IF PROPOSAL IS TO DEEPEN OR PLUG BACK, GIVE DATA ON PRESENT PRODUCTIVE ZONE AND PROPOSED NEW PRODUCTIVE ZONE. GIVE BLOWOUT PREVENTER PROGRAM, IF ANY.

I hereby certify that the information above is true and complete to the best of my knowledge and belief.

Signed R. S. Lane R. S. Lane Title Asst. Petr. Engrg. Mgr. Date July 3, 1984

ORIGINAL SIGNED BY JERRY SEXTON  
DISTRICT I SUPERVISOR

APPROVED BY \_\_\_\_\_ TITLE \_\_\_\_\_ DATE JUL 12 1984

CONDITIONS OF APPROVAL, IF ANY:

NEW MEXICO OIL CONSERVATION COMMISSION  
WELL LOCATION AND ACREAGE DEDICATION PLAT

Form O-102  
Supersedes C-128  
Effective 1-1-85

All distances must be from the outer boundaries of the Section.

Operator <b>Texaco Inc.</b>		Lease <b>New Mexico "J" State</b>			Well No. <b>4</b>
Map Letter <b>F</b>	Section <b>24</b>	Township <b>19-S</b>	Range <b>36-E</b>	County <b>Lea</b>	
Actual Well Location of Well: <b>1980'</b> feet from the <b>North</b> line and <b>2310'</b> feet from the <b>West</b> line					
Ground Level Elev. <b>3711'</b>	Producing Formation <b>Grayburg</b>		Pool <b>Eunice Monument (G-SA)</b>	Dedicated Acreage: <b>40</b> Acres	

1. Outline the acreage dedicated to the subject well by colored pencil or hachure marks on the plat below.
2. If more than one lease is dedicated to the well, outline each and identify the ownership thereof (both as to working interest and royalty).
3. If more than one lease of different ownership is dedicated to the well, have the interests of all owners been consolidated by communitization, unitization, force-pooling, etc?

Yes  No If answer is "yes!" type of consolidation \_\_\_\_\_

If answer is "no!" list the owners and tract descriptions which have actually been consolidated. (Use reverse side of this form if necessary.) \_\_\_\_\_

No allowable will be assigned to the well until all interests have been consolidated (by communitization, unitization, forced-pooling, or otherwise) or until a non-standard unit, eliminating such interests, has been approved by the Commission.

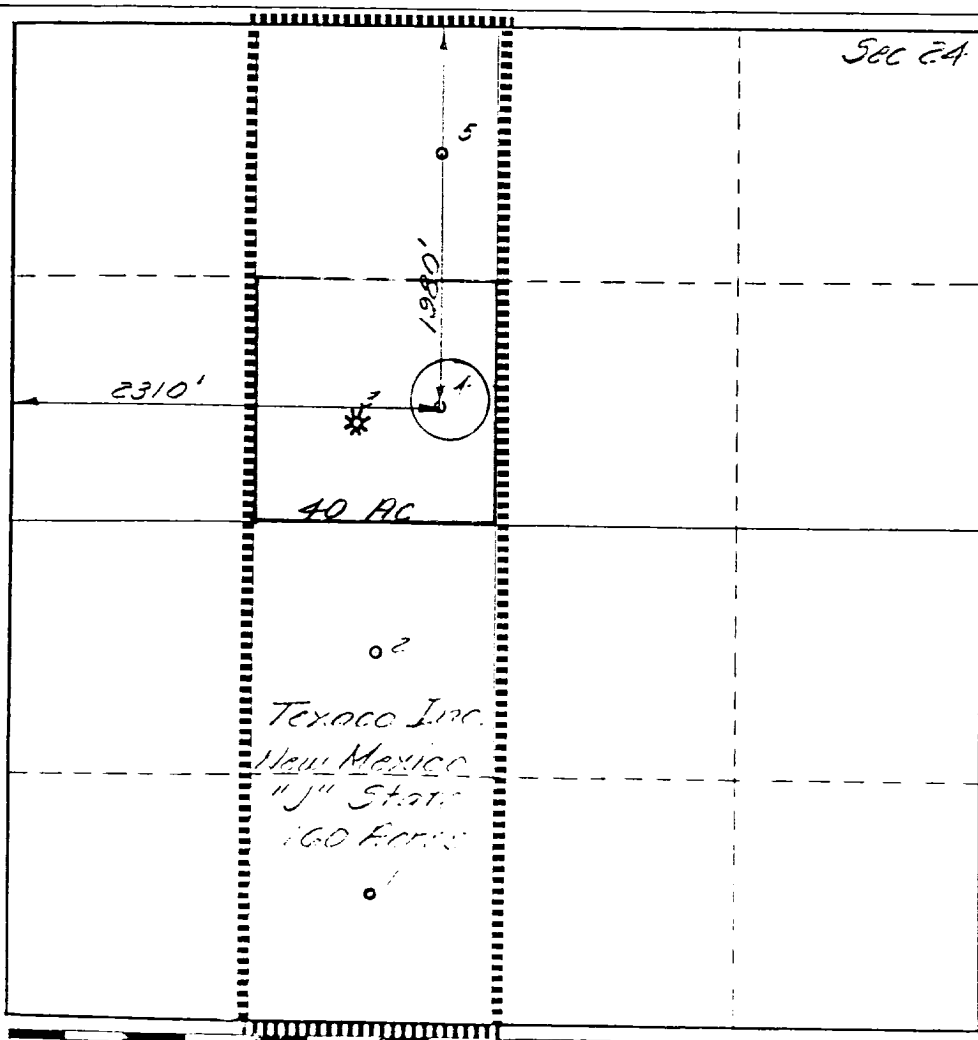

CERTIFICATION

I hereby certify that the information contained herein is true and complete to the best of my knowledge and belief.

*B. L. Eiland*  
Name  
**B. L. Eiland**  
Position  
**Division Surveyor**  
Company  
**Texaco Inc.**  
Date  
**July 3, 1984**

I hereby certify that the well location shown on this plat was plotted from field notes of actual surveys made by me or under my supervision, and that the same is true and correct to the best of my knowledge and belief.

\_\_\_\_\_  
Date  
**June 28, 1984**

*B. L. Eiland*  
**B. L. Eiland**  
Surveyor  
4386

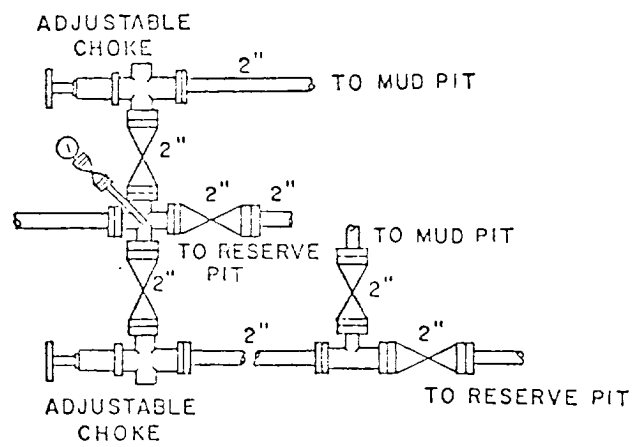
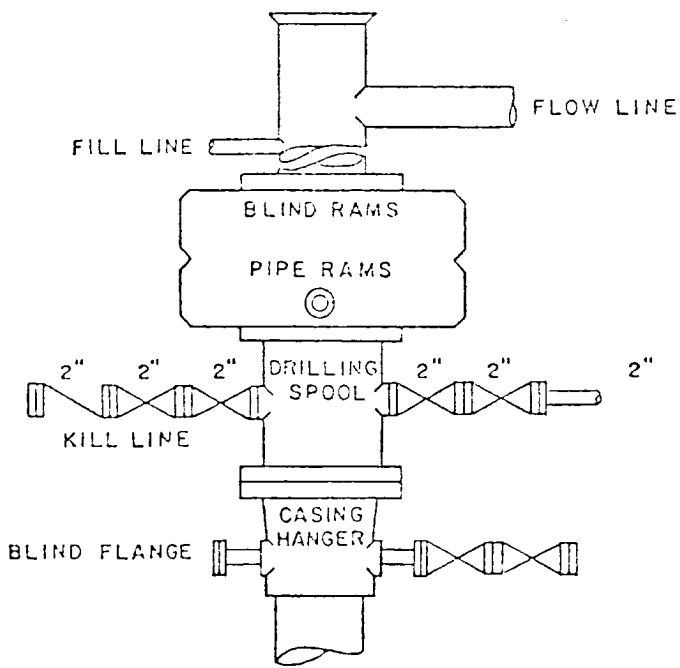

DATE	REVISED	DATE	EST. NO.	DRG. NO.
DRAWN BY JWD				
CHECKED BY KDW				
APPROVED BY				



TEXACO, INC.  
 PRODUCING DEPARTMENT (EAST)  
 MIDLAND, TEXAS

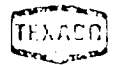

EXHIBIT "8"

RECEIVED

JUL 11 1984

NOBBLE

