

ATS-08-991

RECEIVED

Secretary's Potash

OCD-HOBBS

JUN 26 2009

EA-09-167

HOBBSOCD

Form 3160-3 (April 2004)

UNITED STATES DEPARTMENT OF THE INTERIOR BUREAU OF LAND MANAGEMENT

APPLICATION FOR PERMIT TO DRILL OR REENTER

FORM APPROVED OMB No 1004-0137 Expires March 31, 2007

Form fields including: 1a. Type of work: [X] DRILL [ ] REENTER; 1b. Type of Well: [X] Oil Well [ ] Gas Well [ ] Other [X] Single Zone [ ] Multiple Zone; 2. Name of Operator: Edge Petroleum Operating Company; 3a. Address: 1301 Travis Suite 2000 Houston, TX 77002; 3b. Phone No.: 713-335-9808; 4. Location of Well: 1685' FSL & 990' FWL; 12. County or Parish: Lea Co; 13. State: NM; 14. Distance in miles and direction from nearest town or post office\*: 6 miles southwest direction from Malaga NM; 15. Distance from proposed\* location to nearest property or lease line, ft: 990'; 16. No. of acres in lease: 2320 acres; 17. Spacing Unit dedicated to this well: SE/4 SW/4 of Sec 27; 18. Distance from proposed location\* to nearest well, drilling, completed, applied for, on this lease, ft: 743'; 19. Proposed Depth: 8000'; 20. BLM/BIA Bond No on file: NMB000121; 21. Elevations (Show whether DF, KDB, RT, GL, etc.): 3572' GL; 22. Approximate date work will start\*: 04/15/2009; 23. Estimated duration: 30 days.

24. Attachments

The following, completed in accordance with the requirements of Onshore Oil and Gas Order No. 1, shall be attached to this form

- 1. Well plat certified by a registered surveyor
2. A Drilling Plan.
3. A Surface Use Plan (if the location is on National Forest System Lands, the SUPO shall be filed with the appropriate Forest Service Office).
4. Bond to cover the operations unless covered by an existing bond on file (see Item 20 above)
5. Operator certification
6. Such other site specific information and/or plans as may be required by the authorized officer.

25 Signature: Angela Lightner; Name (Printed/Typed): Angela Lightner; Title: Consultant; Date: 10/03/2008

Approved by (Signature): William Merhege; Name (Printed/Typed): William Merhege; Title: STATE DIRECTOR; Office: NM STATE OFFICE; Date: JUN 23 2009

Application approval does not warrant or certify that the applicant holds legal or equitable title to those rights in the subject lease which would entitle the applicant to conduct operations thereon. Conditions of approval, if any, are attached. APPROVAL FOR TWO YEARS

Title 18 U.S.C. Section 1001 and Title 43 U.S.C. Section 1212, make it a crime for any person knowingly and willfully to make to any department or agency of the United States any false, fictitious or fraudulent statements or representations as to any matter within its jurisdiction

\*(Instructions on page 2)

CAPTAIN CONTROLLED WATER BASIN

SEE ATTACHED FOR CONDITIONS OF APPROVAL

APPROVAL SUBJECT TO GENERAL REQUIREMENTS AND SPECIAL STIPULATIONS ATTACHED

United States Department of the Interior  
Bureau of Land Management  
Roswell Field Office  
2909 Second Street  
Roswell, New Mexico 88201-1287

Statement Accepting Responsibility for Operations

Operator Name: Edge Petroleum Operating Company, Inc.  
Street or Box: 1301 Travis, Suite 2000  
City, State: Houston, Texas  
Zip Code: 77002

The undersigned accepts all applicable terms, conditions, stipulations, and restrictions concerning operations conducted on the leased land or portion thereof, as described below:

Lease No: NM 12412

Legal Description of Land:

Lea  
Township 19 South, Range 32 East, Eddy, New Mexico

SE/4 SW/4 of Section 27

Bond Coverage:

Statewide Oil and Gas Surety Bond, Edge Petroleum Operating Company, Inc.

**BLM Bond File No.:** NMB-000121

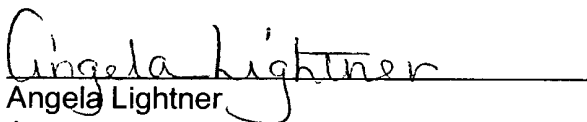
  
Angela Lightner

Agent  
October 3, 2008

RECEIVED

State of New Mexico

DISTRICT I  
1625 N. FRENCH DR., HOBBS, NM 88240

JUN 26 2008

Energy, Minerals and Natural Resources Department

Form C-102

DISTRICT II  
1301 W. GRAND AVENUE, ARTESIA, NM 88210

HOBBSD CONSERVATION DIVISION  
1220 SOUTH ST. FRANCIS DR.  
Santa Fe, New Mexico 87505

Revised October 12, 2005  
Submit to Appropriate District Office  
State Lease - 4 Copies  
Fee Lease - 3 Copies

DISTRICT III  
1000 Rio Brazos Rd., Aztec, NM 87410

DISTRICT IV  
1220 S. ST. FRANCIS DR., SANTA FE, NM 87505

WELL LOCATION AND ACREAGE DEDICATION PLAT

AMENDED REPORT

API Number 30-025-39456	Pool Code 41460	Pool Name Lusk Bone Spring South
Property Code 36920	Property Name SOUTHEAST LUSK 27 FEDERAL	
OGRID No 224400	Operator Name EDGE PETROLEUM OPERATING CO.	
	Well Number 5	Elevation 3572'

Surface Location

UL or lot No.	Section	Township	Range	Lot Idn	Feet from the	North/South line	Feet from the	East/West line	County
L	27	19-S	32-E		1685	SOUTH	990	WEST	LEA

Bottom Hole Location If Different From Surface

UL or lot No.	Section	Township	Range	Lot Idn	Feet from the	North/South line	Feet from the	East/West line	County

Dedicated Acres 40	Joint or Infill	Consolidation Code	Order No.
-----------------------	-----------------	--------------------	-----------

NO ALLOWABLE WILL BE ASSIGNED TO THIS COMPLETION UNTIL ALL INTERESTS HAVE BEEN CONSOLIDATED OR A NON-STANDARD UNIT HAS BEEN APPROVED BY THE DIVISION

<p>SEE DETAIL</p> <p>990'</p> <p>1685'</p> <p>DETAIL</p> <p>3575.6'</p> <p>3574.9'</p> <p>600'</p> <p>600'</p> <p>3569.7'</p> <p>3571.7'</p>	<p>OPERATOR CERTIFICATION</p> <p>I hereby certify that the information herein is true and complete to the best of my knowledge and belief, and that this organization either owns a working interest or unleased mineral interest in the land including the proposed bottom hole location or has a right to drill this well at this location pursuant to a contract with an owner of such mineral or working interest, or to a voluntary pooling agreement or a compulsory pooling order heretofore entered by the division.</p> <p>Cynthia Lightner 9-3-08 Signature Date</p> <p>Cynthia Lightner Printed Name</p>
	<p>SURVEYOR CERTIFICATION</p> <p>I hereby certify that the well location shown on this plat was plotted from field notes of actual surveys made by me or under my supervision, and that the same is true and correct to the best of my belief.</p> <p>AUGUST 15, 2008</p> <p>Date Surveyed AR</p> <p>Signature &amp; Seal of Professional Surveyor</p> <p>Ronald J. Eidson 8/27/08 08-114328</p>
	<p>Certificate No GARY EIDSON 12641 RONALD J EIDSON 3239</p>

8 POINT DRILLING PROGRAM

**EDGE PETROLEUM OPERATING COMPANY, INC.**  
**SOUTHEAST LUSK "27" FEDERAL #5**

Section 27 T-19-S, R-32-E  
Lea County, New Mexico

The following items supplement Form 3160-3 in accordance with instructions contained in Onshore Oil and Gas Orders #1 and #2, and all other applicable federal and state regulations.

**1. ESTIMATED TOPS OF GEOLOGIC MARKERS (TVD)**

Anhydrite	Water	890'
Yates	Water	2,665'
Capitan	Water	3,525'
Delaware	Oil	4,240'
Cherry Canyon	Oil	4,748'
Brushy Canyon	Oil	5,877'
Lwr Brushy Canyon	Oil	7,174'
1 <sup>st</sup> Bone Springs Lm	Oil	7,424'
Bone Springs Lm Pay	Oil	7,616'
Total Depth		8,000'

**2. PRESSURE CONTROL EQUIPMENT** The blow out preventer equipment (BOP) shown in Exhibit #1 will consist of a 3000 psi double ram type preventer for drilling the 13-1/2" hole. The blowout preventer stack for the production 6-3/4" hole as shown on Exhibit #2 will consist of at least a double-ram blowout preventer and annular preventer rated to 5000 psi working pressure. A diagram of the BOPs and choke manifold is attached. All BOPs and accessory equipment will be tested according to Onshore Order #2 before drilling out.

**3. PROPOSED CASING PROGRAM**

<u>Hole Sz</u>	<u>Interval</u>	<u>Csg</u>	<u>Wt</u>	<u>Grade, Joint</u>	<u>Collapse</u>	<u>Tension</u>	<u>Burst</u>
20"	0 - 40'	20"	52.8#	X-42, BPE			
18-1/2"	0 - 890'	16"	65#	H-40, STC	1.65	4.03	8.76
13-1/2"	0 - 3,080'	10-3/4"	45.5#	J-55, STC	1.28	2.19	6.73
9-1/2"	0 - 4,270'	7-5/8"	29.7#	HPG-110, LTC	2.07	4.39	6.77
6-3/4"	0 - 8,000'	5-1/2"	17#	P-110, Ultra FJ	2.72	3.29	3.38

All casing for this project is new casing

There will be a DV Tool above an External Casing Packer (ECP) which is to be set inside the 13-1/2" casing at 3000 +/-'. Cement will be circulated to surface. Equivalent or adequate grades and weights of casing may be substituted at time casing is run, depending on availability. Changes will be relayed to BLM prior to running.

see  
COA

see  
COA

**4. PROPOSED CEMENTING PROGRAM** ← see COA

20" conductor cemented with ready mix to surface  
 16" surf. Lead Slurry - 385 sxs "C" cement + 4% D20 + 2% S1 + 3 pps D42 slurry wt.- 13.5, yield - 1.75 ft<sup>3</sup>/sk  
 Tail Slurry - 155 sxs "C" cement + 2% S1, slurry wt.- 14.8, yield - 1.34 ft<sup>3</sup>/sk, TOC - surface

10-3/4" 1st inter. Lead Slurry - 1015 sxs 35:65 Poz: "C" cement + 5% D44 bwow + 6% D20 + 3 pps D42 + 0.25pps D29, slurry wt. - 12.4, yield- 2.17 ft<sup>3</sup>/sk  
 Tail Slurry - 375 sxs "C" cement + 1% S1, slurry wt.- 14.8, yield - 1.33 ft<sup>3</sup>/sk, TOC - surface.

7-5/8" 2<sup>nd</sup> inter. 1<sup>st</sup> stage Lead Slurry - 70 sxs 50:50 Poz: "C" cement + 6% D44 bwow + 10% D20 + 0.25 pps D29 + 3 pps D42, slurry wt.- 11.9, yield - 2.51 ft<sup>3</sup>/sk  
 1 stage Tail Slurry - 105 sxs "C" cement + 0.25 pps D29, slurry wt.-14.8, yield - 1.32 ft<sup>3</sup>/sk, TOC - 3,000'  
 2nd stage Lead Slurry- 300 sxs 50:50 Poz: "C" cement + 6% D44 bwow + 10% D20 + 0.25 pps D29 + 1 pps D42, slurry wt.- 11.9, yield- 2.5 ft<sup>3</sup>/sk, TOC- surface  
 2nd stage Tail Slurry- 60 sxs "C" cement + 0.25 pps D29, slurry wt.- 14.8, yield - 1.32 ft<sup>3</sup>/sk, TOC- surface

5-1/2" prod. Lead Slurry- 485 sxs 50:50 Poz: "H" cement + 5% D44 bwow + 2% D20 + 0.125 pps D29 + 1 pps D42, slurry wt. - 14.2, yield - 1.36 ft<sup>3</sup>/sk, TOC- surface

see COA →

↑  
see COA

**5. PROPOSED MUD SYSTEM**

<u>DEPTH</u>	<u>DESCRIPTION</u>	<u>MUD WEIGHT</u>	<u>VISCOSITY</u>	<u>WATER LOSS</u>
0 - 890'	Fresh water	8.4 - 9.4 ppg	32 - 34	NC
890' - 3,080'	Brine water	10.0 ppg	28	NC
3,080' - 4,270'	Fresh water	8.3 - 8.5 ppg	28	NC
4,270' - 7,200'	Fresh water	8.4 - 8.5 ppg	28	NC
7,200' - 8,000'	Fresh water	8.5 - 8.7 ppg	30 - 32	12cc

see COA ←

**6. TESTING, LOGGING AND CORING PROGRAM**

Samples None are planned  
 DST's None are planned  
 Logging Neutron/Density and Resistivity  
 Coring Possible sidewall core

**7. ABNORMAL PRESSURES AND TEMPERATURES**

None anticipated. Maximum bottom hole pressure should not exceed 4,000 psi. Maximum bottom hole temperature should not exceed 117°. This area has a potential H<sub>2</sub>S hazard. An H<sub>2</sub>S drilling plan is attached and a contingency program has been done and on file with the BLM.

**8. ANTICIPATED STARTING DATE AND DURATION OF OPERATIONS**

It is planned that operations will commence on or about April 15, 2009. Drilling should be completed within 30 days followed by completion operations.

## **HYDROGEN SULFIDE DRILLING OPERATIONS PLAN**

### **EDGE PETROLEUM OPERATING COMPANY, INC.**

#### **Southeast Lusk "27" Federal #5**

#### **I. HYDROGEN SULFIDE TRAINING**

- A.** All regularly assigned personnel, contracted or employed by Edge Petroleum Corporation, will receive training from a qualified instructor in the following areas prior to commencing drilling potential hydrogen sulfide bearing formations in this well:
1. The hazards and characteristics of hydrogen sulfide (H<sub>2</sub>S).
  2. The proper use and maintenance of personal protective equipment and life support systems.
  3. The proper use of H<sub>2</sub>S detectors, alarms, warning systems, briefing areas, evacuation procedures and prevailing winds.
  4. The proper techniques for first aid and rescue procedures.
- B.** In addition, supervisory personnel will be trained in the following areas:
1. The effects of H<sub>2</sub>S on metal components. If high tensile tubulars are to be used, personnel will be trained in their special maintenance requirements.
  2. Corrective action and shut-in procedures when drilling or reworking a well and blowout prevention and well control procedures.
  3. The contents and requirements of the H<sub>2</sub>S Drilling Operations Plan.
- C.** There will be an initial training session just prior to encountering a known or probable H<sub>2</sub>S zone (within 3 days or 500 feet) and weekly H<sub>2</sub>S and well control drills for all personnel in each crew. The initial training session shall include a review of the site specific H<sub>2</sub>S Drilling Operations Plan. This plan shall be available at the well site. All personnel will be required to carry documentation that they have received the proper training.

## II. H<sub>2</sub>S SAFETY EQUIPMENT AND SYSTEMS

Note: All H<sub>2</sub>S safety equipment and systems will be installed, tested and operational when drilling reaches a depth of 500 feet above, or three days prior to penetrating the first zone containing or reasonably expected to contain H<sub>2</sub>S.

### A. Well Control Equipment

1. Flare line with continuous pilot.
2. Choke manifold with a minimum of one remote choke.
3. Blind rams and pipe rams to accommodate all pipe sizes with properly sized closing unit.
4. Auxiliary equipment to include: annular preventer, mud-gas separator, rotating head and flare.

### B. Protective Equipment for Essential Personnel

Mark II Surviveair 30-minute units located in the doghouse and at briefing areas, as indicated on well site diagram.

### C. H<sub>2</sub>S Detection and Monitoring Equipment

1. Two portable H<sub>2</sub>S monitors positioned on location for best coverage and response. These units have warning lights and audible sirens when H<sub>2</sub>S levels of 20 ppm are reached.
2. One portable SO<sub>2</sub> monitor positioned near flare line.

### D. Visual Warning Systems

1. Wind direction indicators are shown on well site diagram.
2. Caution/Danger signs shall be posted on roads providing direct access to location. Signs will be painted a high visibility yellow with black lettering of sufficient size to be readable at a reasonable distance from the immediate location. Bilingual signs will be used when appropriate. See example attached.



**E. Mud Program**

- 1.** The Mud Program has been designed to minimize the volume of H<sub>2</sub>S circulated to the surface. Proper mud weights, safe drilling practices and the use of H<sub>2</sub>S scavengers will minimize hazards when penetrating H<sub>2</sub>S bearing zones.
- 2.** A mud-gas separator will be utilized as needed.

**F. Metallurgy**

All drill strings, casing, tubing, wellhead, blowout preventers, drilling spool, kill lines, choke manifold and line and valves shall be suitable for H<sub>2</sub>S service.

**G. Communication**

Cellular telephone communications in company vehicles, rig floor and mud logging trailer.

**H. Well Testing**

Drill stem testing will be performed with a minimum number of personnel in the immediate vicinity, which are necessary to safely and adequately conduct the test. The drill stem testing and an H<sub>2</sub>S environment will be conducted during the daylight hours.

# Schlumberger

## PRIMARY CEMENTING PROPOSAL

### 4 CASING STRINGS

---

## *Edge Petroleum*

### *SE Lusk 27 Fed. 5*

---

#### Well Location

County : Lea  
State : New Mexico  
Country : USA

Prepared for : Angela  
Date Prepared : 8-Sep-08  
Service Point : HOBBS, NM  
Business Phone : 505-393-6186  
FAX No. : 505-393-2132

Prepared by : Bear Bryant  
Phone : 505-393-6186  
FAX : 505-393-2132  
E-Mail address : bryant8@hobbs.oilfield.slb.com

#### Disclaimer Notice

This information is presented in good faith, but no warranty is given and Dowell assumes no liability for advice or recommendations made concerning results to be obtained from the use of any product or service. Prices quoted are estimates only, and are good for 30 days from the date of issue. Actual charges may vary depending upon time, equipment, and material, ultimately required to perform these services. Freedom from infringement of patents of Dowell or others is not to be inferred.

**Well Data: 13 3/8 in. Surface Casing**

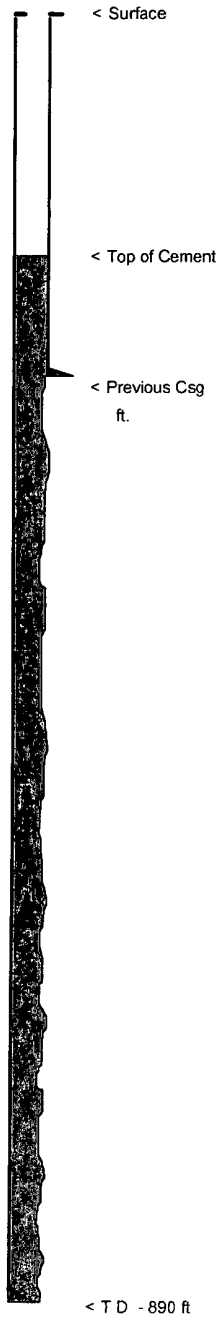

Depth	890 ft.
Casing Size	13 3/8 in., 54.5 lbs./ft.
Open Hole Diameter	17 1/2 in.
BHST	80 °F
BHCT	80.0 °F
Total Excess	100 %
Lead Excess (calculated O.H.)	100.0 %
Tail Excess	100 %

**Mud Wt./Type: 8.5 ppg Fresh Wtr. Based**

**Calculations:**

**Volume Factors:**

Casing x Open Hole	0.6946 cu.ft./ft
Casing (Internal)	0.8675 cu.ft./ft

<b>Top of Lead</b>	<b>Surface</b>
<b>Top of Tail</b>	<b>720 ft.</b>

**Lead System:**

Total Lead Fill                     $(720 \times 0.6946 \times 2.0) / 1.75 = 570 \text{ sks.}$

**Tail System:**

Open Hole Fill                     $(170 \times 0.6946 \times 2.) / 1.34 = 176 \text{ sks.}$   
 Casing Shoe Cement             $(40 \times 0.8675) / 1.34 = 26 \text{ sks.}$   
 Total Tail Cement = 202 sks.

## Cementing Systems

### **Lead System: 570 sks.**

#### **Class C + 4% D20 + 2% S1 + 3 pps D42**

Mix Weight	:	13.5	PPG	
Yield	:	1.75	cu.ft./sk.	
Mix Water	:	8.95	gal./sk.	(Fresh Water)

### **Tail System: 200 sks.**

#### **Class C + 2% S1**

Mix Weight	:	14.8	PPG	
Yield	:	1.34	cu.ft./sk.	
Mix Water	:	6.3	gal./sk.	(Fresh Water)

Notice

Performance parameters for cement systems recommended are typically taken from existing laboratory data. In some cases, data exist which duplicate the recommended systems and job environment, but when those data do not exist, extrapolations are made from data which most closely match the anticipated conditions. Sufficient lead-time should always be allowed, so that pilot samples/field blends can be run to verify system performance parameters, before actually pumping the job.

**Well Data: 10 3/4 in. Intermediate Casing**

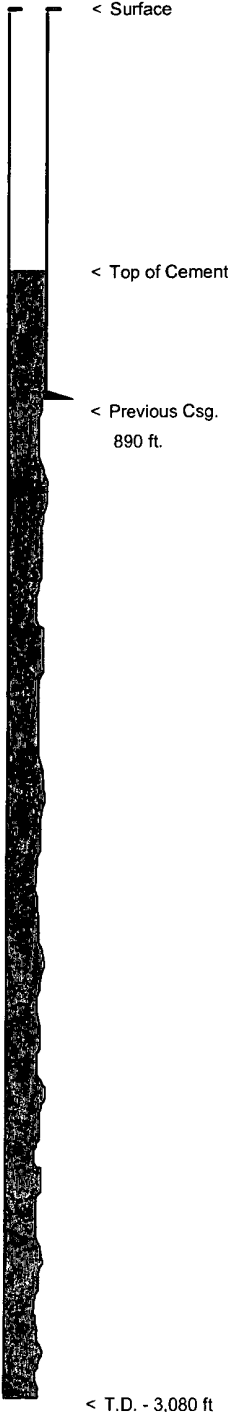

Depth	3,080 ft.
Casing Size	10 3/4 in., 45.5 lbs./ft.
Open Hole Diameter	12 1/4 in.
Previous Csg. Depth	890 ft.
Previous Csg. Size	13 3/8 in., 54.5 lbs./ft.
BHST	95 °F
BHCT	80.0 °F
Total Excess	165 %
Lead Excess (calculated O.H.)	241.5 %
Tail Excess	50 %

**Mud Wt./Type: 8.5 ppg Brine Based**

**Calculations:**

**Volume Factors:**

Casing x Open Hole	0.1882 cu.ft./ft
Casing x Previous Casing	0.2372 cu.ft./ft
Casing (Internal)	0.54 cu.ft./ft

<b>Top of Lead</b>	<b>Surface</b>
<b>Top of Tail</b>	<b>2,205 ft.</b>

**Lead System:**

Open Hole Fill	$(1,315 \times 0.1882 \times 3.42) / 2.17 = 390$ sks.
Previous Casing Fill	$(890 \times 0.2372) / 2.17 = 98$ sks.
Total Lead Cement = 487 sks.	

**Tail System:**

Open Hole Fill	$(875 \times 0.1882 \times 1.5) / 1.33 = 186$ sks.
Casing Shoe Cement	$(40 \times 0.54) / 1.33 = 16$ sks.
Total Tail Cement = 202 sks.	

< T.D. - 3,080 ft

## Cementing Systems

### **Lead System: 485 sks.**

**35:65 Poz:Class C + 5% D44 (bwow) + 6% D20 + 3 pps D42 + 0.25 pps D29**

Mix Weight	:	12.4 PPG	
Yield	:	2.17 cu.ft./sk.	
Mix Water	:	11.86 gal./sk.	(Fresh Water)

### **Tail System: 200 sks.**

#### **Class C + 1% S1**

Mix Weight	:	14.8 PPG	
Yield	:	1.33 cu.ft./sk.	
Mix Water	:	6.3 gal./sk.	(Fresh Water)

Notice

Performance parameters for cement systems recommended are typically taken from existing laboratory data. In some cases, data exist which duplicate the recommended systems and job environment, but when those data do not exist, extrapolations are made from data which most closely match the anticipated conditions. Sufficient lead-time should always be allowed, so that pilot samples/field blends can be run to verify system performance parameters, before actually pumping the job.

## Well Data: 7 5/8 in. 2Nd Intermediate - Stage 1

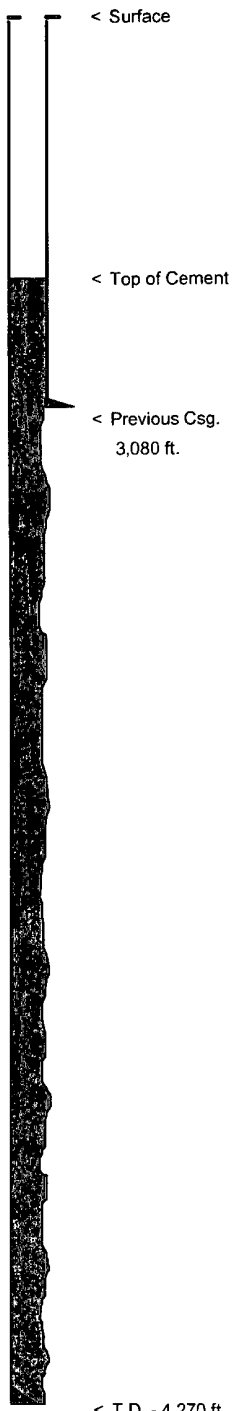

Depth	4,270 ft.
Casing Size	7 5/8 in., 26 lbs./ft.
Open Hole Diameter	9 1/2 in.
Previous Csg. Depth	3,080 ft.
Previous Csg. Size	10 3/4 in., 45.5 lbs./ft.
BHST	115 °F
BHCT	80.0 °F
Total Excess	50 %
Lead Excess (calculated O.H.)	50.0 %
Tail Excess	50 %
Stage Collar Depth	3,000 ft.

### Mud Wt./Type: 9.5 ppg Brine Based

### Calculations:

#### Volume Factors:

Casing x Open Hole	0.1751 cu.ft./ft
Casing x Previous Casing	0.2229 cu.ft./ft
Casing (Internal)	0.2655 cu.ft./ft

<b>Top of Lead</b>	<b>3,080 ft.</b>
<b>Top of Tail</b>	<b>3,770 ft.</b>

#### Lead System:

Total Lead Fill  $(690 \times 0.1751 \times 1.5) / 2.51 = 72$  sks.

#### Tail System:

Open Hole Fill  $(500 \times 0.1751 \times 1.5) / 1.32 = 99$  sks.  
 Casing Shoe Cement  $(40 \times 0.2655) / 1.32 = 8$  sks.  
 Total Tail Cement = 107 sks.

## Cementing Systems

### Lead System: 70 sks.

50:50 Poz:Class C + 6% D44 (bwow) + 10% D20 + 0.25 pps D29 + 3 pps D42

Mix Weight	:	11.9 PPG	
Yield	:	2.51 cu.ft./sk.	
Mix Water	:	14.22 gal./sk.	(Fresh Water)

### Tail System: 105 sks.

Class C + 0.25 pps D29

Mix Weight	:	14.8 PPG	
Yield	:	1.32 cu.ft./sk.	
Mix Water	:	6.3 gal./sk.	(Fresh Water)

Notice

Performance parameters for cement systems recommended are typically taken from existing laboratory data. In some cases, data exist which duplicate the recommended systems and job environment, but when those data do not exist, extrapolations are made from data which most closely match the anticipated conditions. Sufficient lead-time should always be allowed, so that pilot samples/field blends can be run to verify system performance parameters, before actually pumping the job.



**Well Data: 7 5/8 in. 2Nd Intermediate - Stage 2**

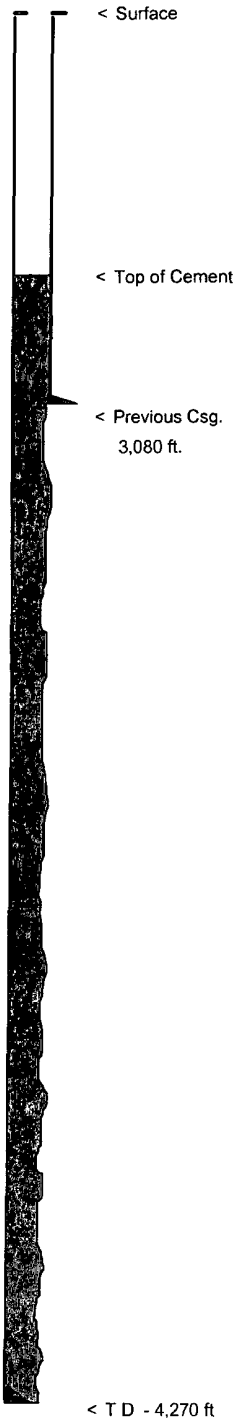

Depth	4,270 ft.
Casing Size	7 5/8 in., 26 lbs./ft.
Open Hole Diameter	9 1/2 in.
Previous Csg. Depth	3,080 ft.
Previous Csg. Size	10 3/4 in., 45.5 lbs./ft.
BHST	115 °F
BHCT	94.8 °F
Total Excess	15 %
Lead Excess (calculated O.H.)	0.0 %
Tail Excess	50 %
Stage Collar Depth	3,000 ft.

**Mud Wt./Type: 9.5 ppg Fresh Wtr. Based**

**Calculations:**

**Volume Factors:**

Casing x Open Hole	0.1751 cu.ft./ft
Casing x Previous Casing	0.2229 cu.ft./ft
Casing (Internal)	0.2655 cu.ft./ft

<b>Top of Lead</b>	<b>Surface</b>
<b>Top of Tail</b>	<b>2,800 ft.</b>

**Lead System:**

Previous Casing Fill       $(2,800 \times 0.2229 \times 1.15) / 2.5 = 287 \text{ sks.}$

**Tail System:**

Previous Casing Fill       $(200 \times 0.2229 \times 1.5) / 1.32 = 50 \text{ sks.}$   
 Casing Shoe Cement       $(40 \times 0.2655) / 1.32 = 8 \text{ sks.}$   
 Total Tail Cement = 58 sks.

## Cementing Systems

### **Lead System: 285 sks.**

**50:50 Poz:Class C + 6% D44 (bwow) + 10% D20 + 0.25 pps D29 + 1 pps D42**

Mix Weight	:	11.9 PPG	
Yield	:	2.5 cu.ft./sk.	
Mix Water	:	14.28 gal./sk.	(Fresh Water)

### **Tail System: 60 sks.**

**Class C + 0.25 pps D29**

Mix Weight	:	14.8 PPG	
Yield	:	1.32 cu.ft./sk.	
Mix Water	:	6.3 gal./sk.	(Fresh Water)

Notice

Performance parameters for cement systems recommended are typically taken from existing laboratory data. In some cases, data exist which duplicate the recommended systems and job environment, but when those data do not exist, extrapolations are made from data which most closely match the anticipated conditions. Sufficient lead-time should always be allowed, so that pilot samples/field blends can be run to verify system performance parameters, before actually pumping the job.

**Well Data: 5 1/2 in. Production Casing**

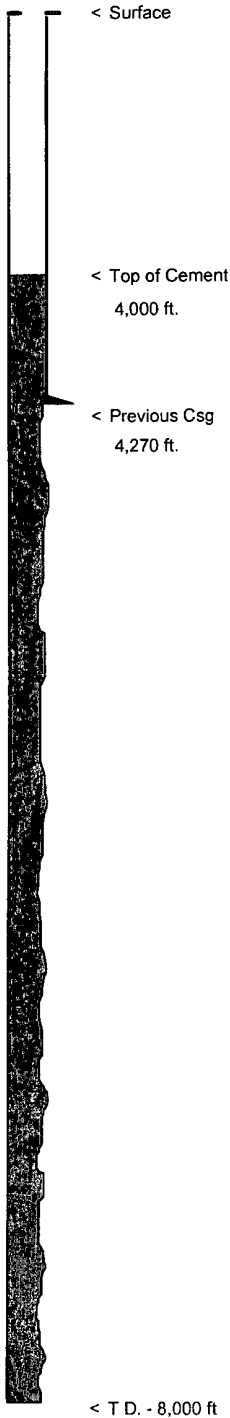

Depth	8,000 ft.
Casing Size	5 1/2 in., 17 lbs./ft.
Open Hole Diameter	6 1/2 in.
Previous Csg. Depth	4,270 ft.
Previous Csg. Size	7 5/8 in., 26 lbs./ft.
BHST	120 °F
BHCT	80.0 °F
Total Excess	50 %
Tail Excess	100 %

**Mud Wt./Type: 9.5 ppg Brine Based**

**Calculations:**

**Volume Factors:**

Casing x Open Hole	0.0654 cu.ft./ft
Casing x Previous Casing	0.1005 cu.ft./ft
Casing (Internal)	0.1312 cu.ft./ft

**Top of Cement 4,000 ft.**

**Cement System:**

Open Hole Fill	$(3,730 \times 0.0654 \times 2.) / 1.36 = 359$ sks.
Previous Casing Fill	$(270 \times 0.1005) / 1.36 = 20$ sks.
Casing Shoe Cement	$(40 \times 0.1312) / 1.36 = 4$ sks.
<b>Total Tail Cement = 383 sks.</b>	

## Cementing Systems

**Spacer System: 20 bbls .**

**CW-100 Chemical Wash**

**Cement System: 385 sks.**

**50:50 Poz:Class H + 5% D44 (bwow) + 2% D20 + 0.125 pps D29 + 1 pps D42**

Mix Weight	:	14.2 PPG	
Yield	:	1.36 cu.ft./sk.	
Mix Water	:	6.28 gal./sk.	(Fresh Water)

Notice.

Performance parameters for cement systems recommended are typically taken from existing laboratory data. In some cases, data exist which duplicate the recommended systems and job environment, but when those data do not exist, extrapolations are made from data which most closely match the anticipated conditions. Sufficient lead-time should always be allowed, so that pilot samples/field blends can be run to verify system performance parameters, before actually pumping the job.

This quote is valid for a period of thirty days from the date submitted. These prices are estimates based on current price structure and will vary somewhat with the materials, equipment, and time actually required at the time of service. The discount shown will be applicable to the most current Dowell price book in effect at the time of service. Not included are the costs of fluid storage, oil, water, (or transportation thereof) except as listed. Dowell does not offer these services.

The cement slurry data presented are from systems previously tested in Dowell laboratories. Thickening time tests should be run when field mix water is available and final temperatures are known. Mud\Cement compatibility tests should be run when final mud systems are in use. These tests could cause quantity variations of the materials recommended, thereby affecting the price of the job.

In the interest of safety, a pre-job tailgate safety meeting will be held with your representative and other on-location personnel to familiarize everyone with existing hazards and safety procedures. During this meeting a designated wash-up area will be assigned for our cementing unit to dispose of our cement slurry and drilling mud displacement fluid.

Thank you for considering Dowell for this work. Please do not hesitate to call with any questions or concerns.

Bear Bryant  
Hobbs, New Mexico

**DRILLING RIG LAYOUT**  
**Edge Petroleum Operating Co., Inc.**  
**Southeast Lusk 27 Federal #5**

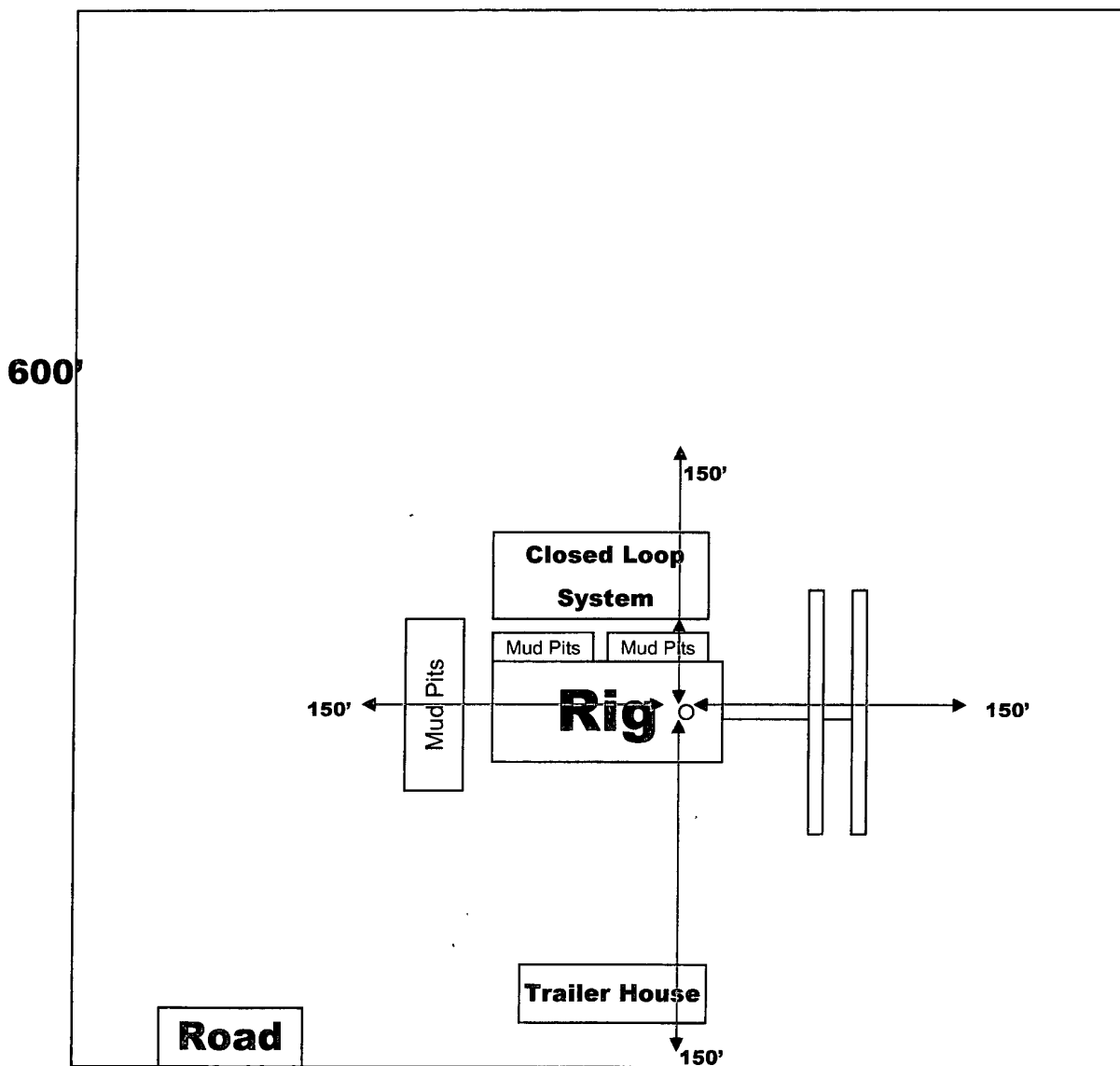
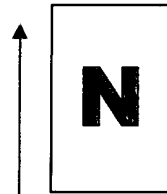

BOP SCHEMATIC FOR  
12 1/4" Hole

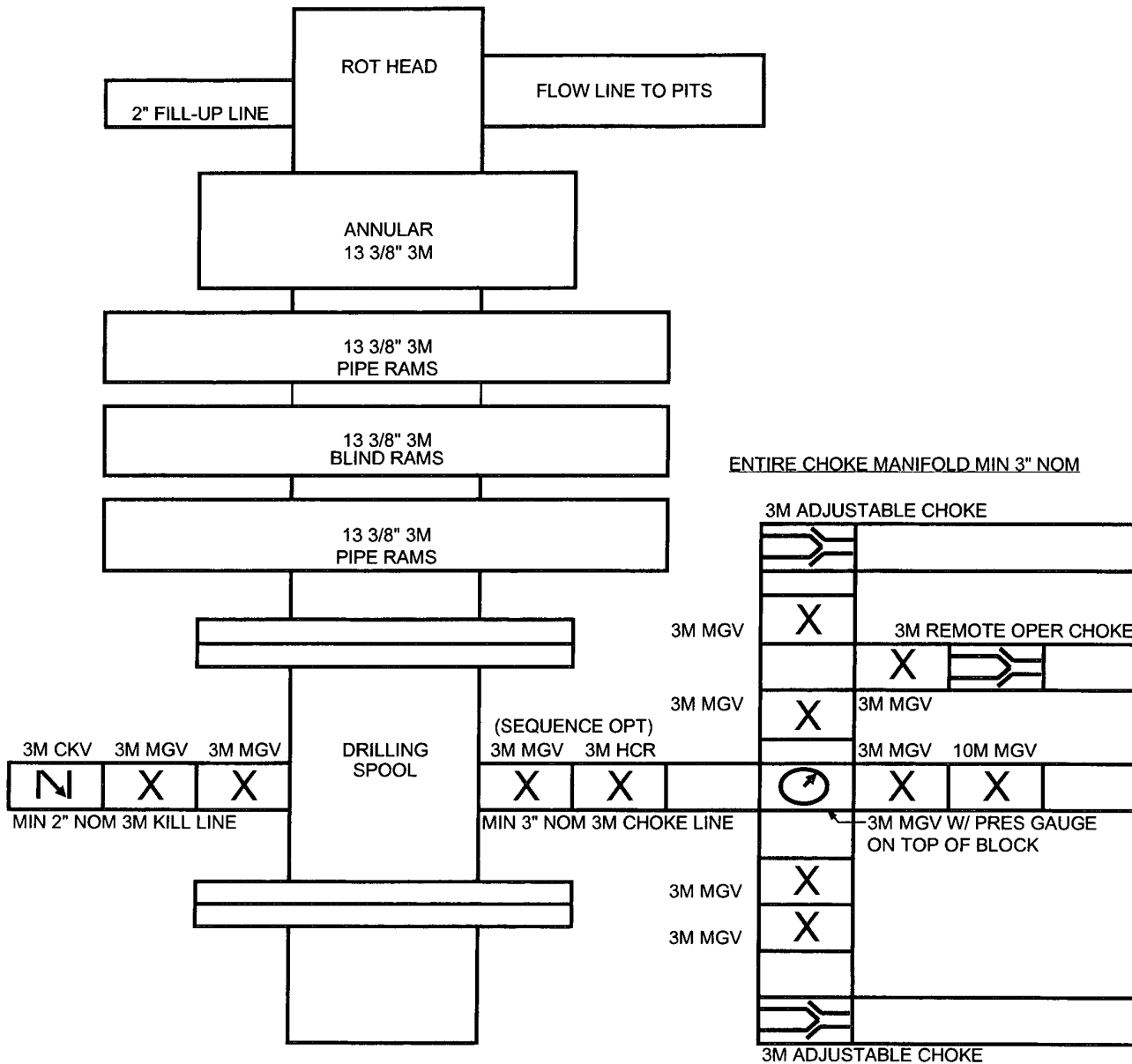

Edge Petroleum  
Southeast Lusk 27 Federal #5  
Lea County, New Mexico

BOP SCHEMATIC FOR  
9 1/2 HOLE

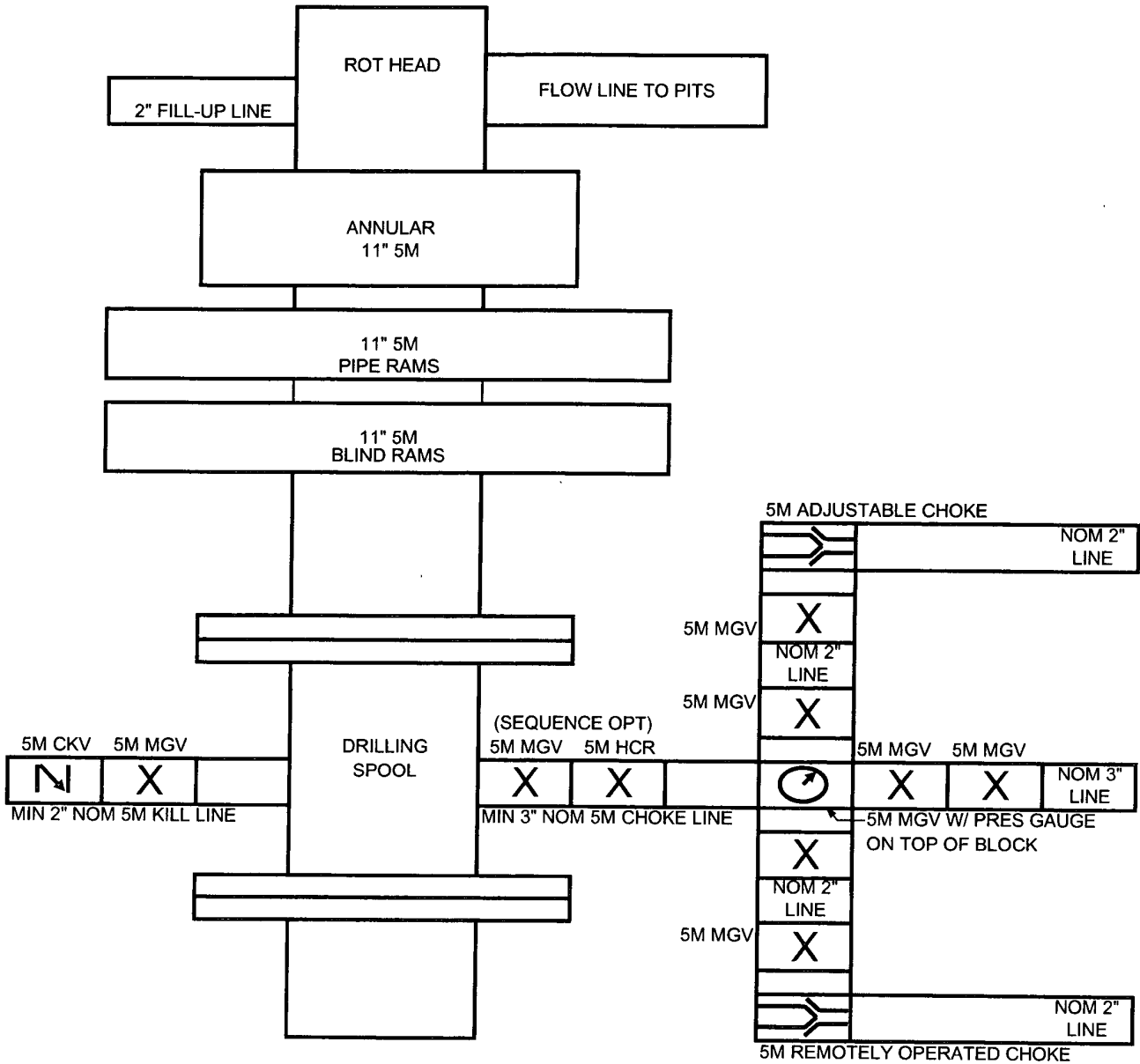

Edge Petroleum  
Southeast Lusk 27 Federal #5  
Lea County, New Mexico



# LOCATION VERIFICATION MAP

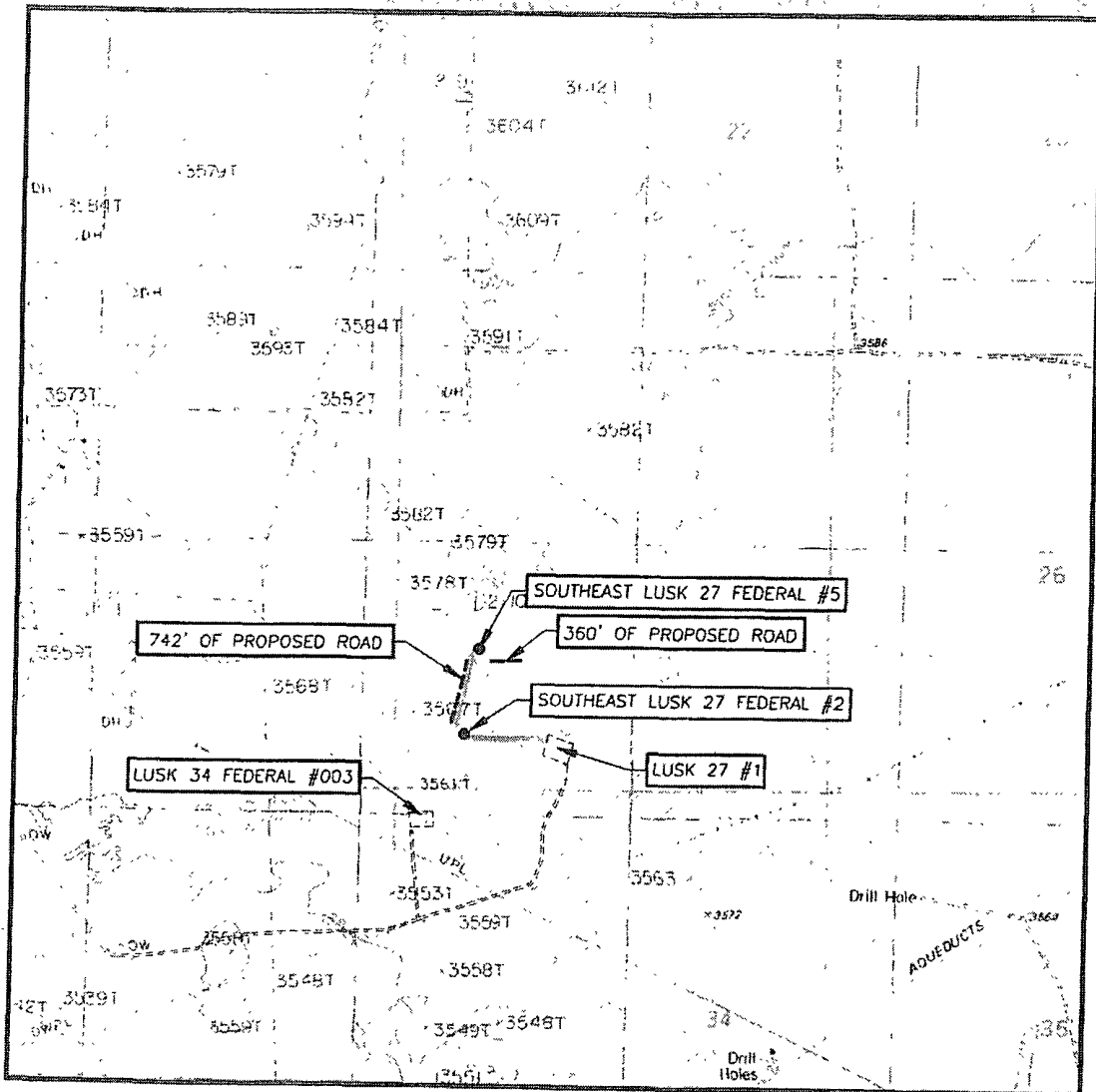

SCALE: 1" = 2000'

SEC. 27 TWP. 19-S RGE. 32-E

SURVEY N.M.P.M.

COUNTY LEA STATE NEW MEXICO

DESCRIPTION 1685' FSL & 990' FWL

ELEVATION 3572'

OPERATOR EDGE PETROLEUM OPERATING CO.

LEASE SOUTHEAST LUSK 27 FEDERAL

U.S.G.S. TOPOGRAPHIC MAP

GREENWOOD LAKE, N.M.

CONTOUR INTERVAL:

WILLIAMS SINK, N.M. - 10'

LAGUNA GATUNA, N.M. - 10'

LAGUNA GATUNA NW, N.M. - 10'

GREENWOOD LAKE, N.M. - 10'

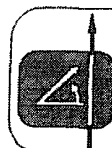

PROVIDING SURVEYING SERVICES  
SINCE 1946  
JOHN WEST SURVEYING COMPANY  
412 N. DAL PASO  
HOBBS, N.M. 88240  
(505) 393-3117

# VICINITY MAP

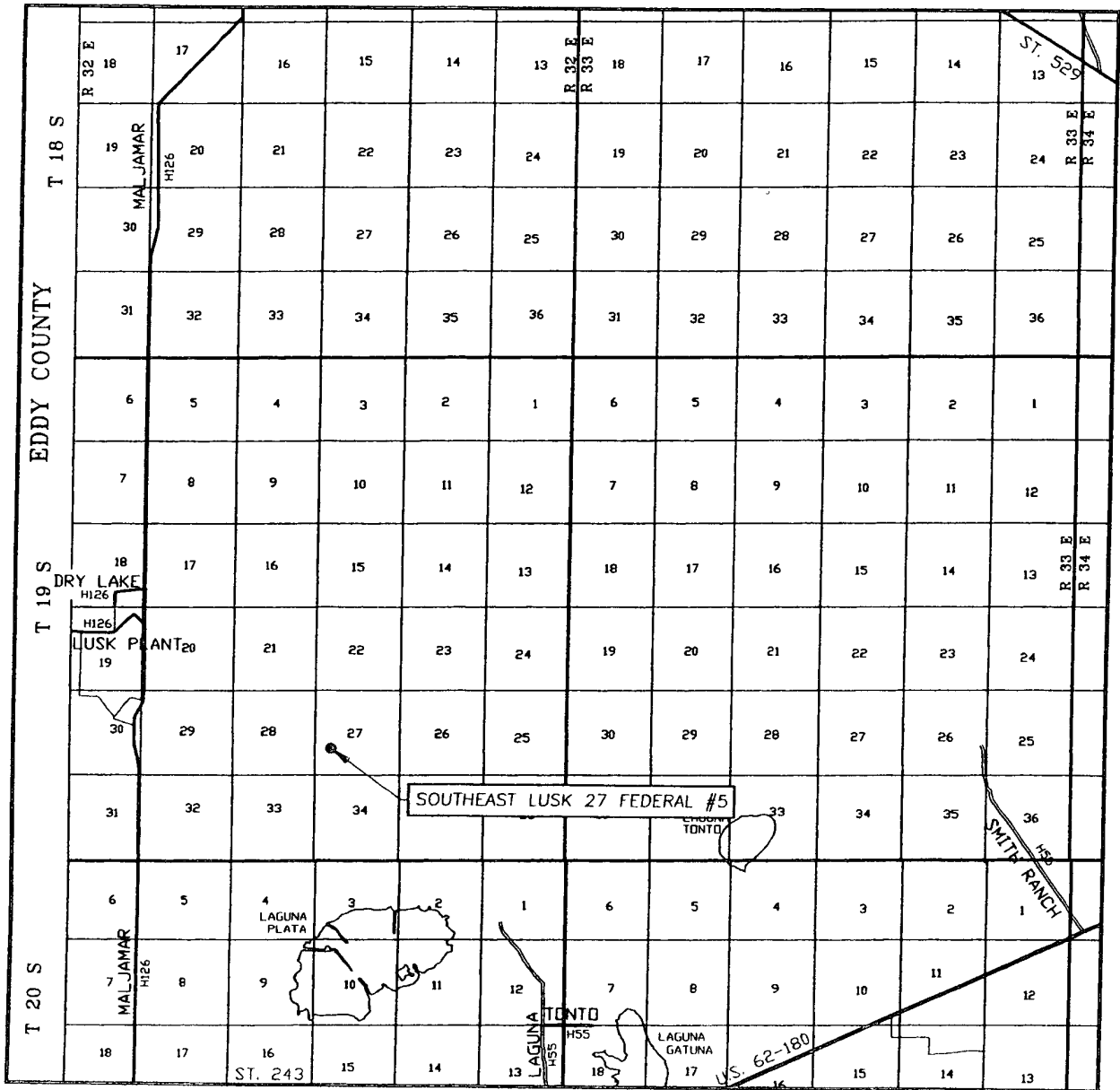

SCALE: 1" = 2 MILES

SEC. 27 TWP 19-S RGE. 32-E  
 SURVEY \_\_\_\_\_ N.M.P.M.  
 COUNTY LEA STATE NEW MEXICO  
 DESCRIPTION 1685' FSL & 990' FWL  
 ELEVATION \_\_\_\_\_ 3572'  
 OPERATOR EDGE PETROLEUM  
OPERATING CO.  
 LEASE SOUTHEAST LUSK 27 FEDERAL



PROVIDING SURVEYING SERVICES  
 SINCE 1946  
**JOHN WEST SURVEYING COMPANY**  
 412 N DAL PASO  
 HOBBS, N.M. 88240  
 (505) 393-3117

Exhibit B

**SECTION 27, TOWNSHIP 19 SOUTH, RANGE 32 EAST, N.M.P.M.,**  
 LEA COUNTY, NEW MEXICO

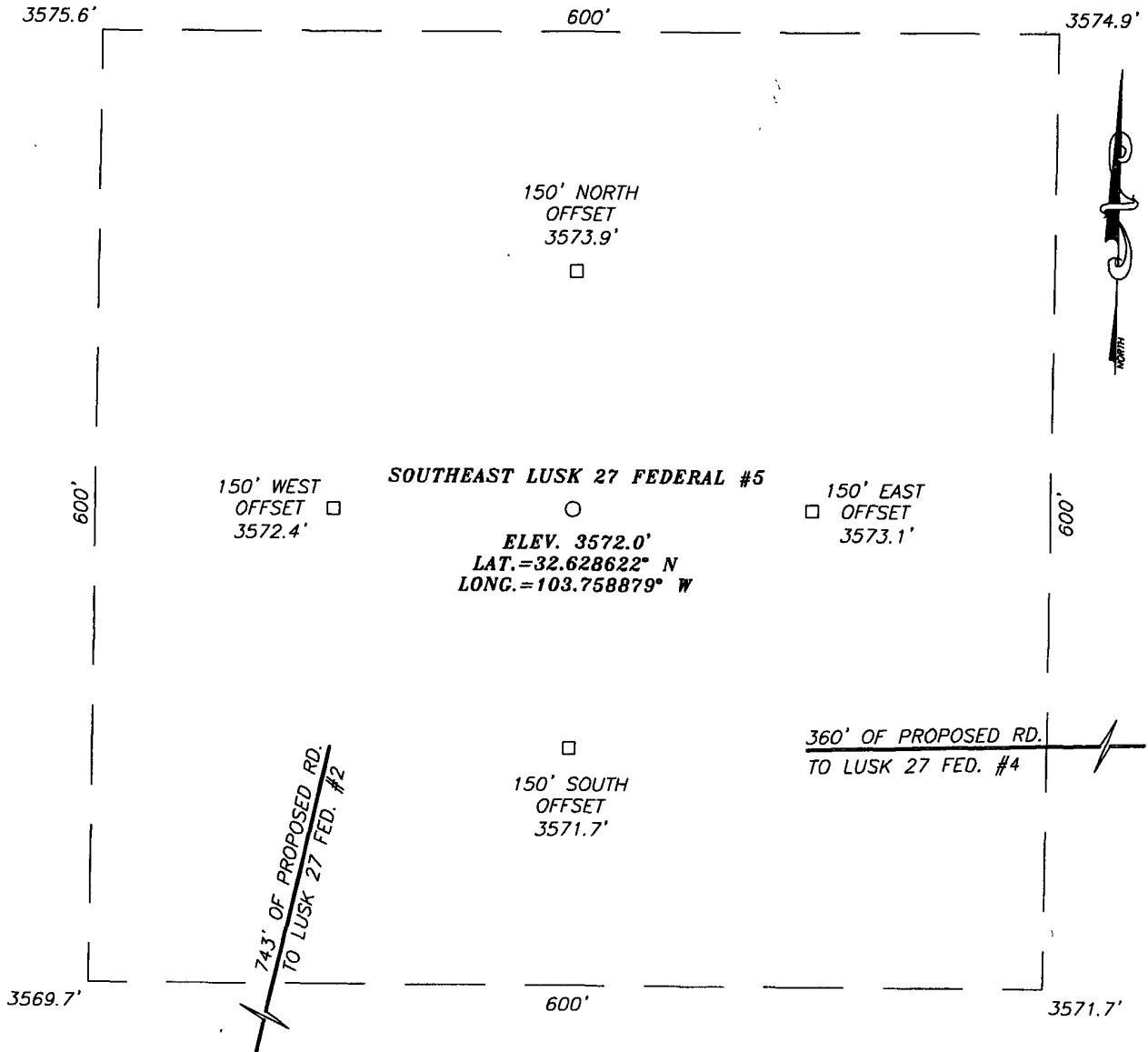

**DIRECTIONS TO LOCATION**

FROM THE INTERSECTION OF ST. HWY. #243 AND CO. RD. H126, GO NORTH ON CO. RD. H126 APPROX. 4.0 MILES. TURN RIGHT AND GO EAST APPROX. 1.1 MILE. TURN RIGHT AND GO SOUTH THEN SOUTHEAST APPROX. 0.5 MILES. BEND LEFT AND GO EAST APPROX. 0.7 MILES. TURN LEFT AND GO NORTH APPROX. 0.2 MILES TO LUSK 34 FEDERAL #3 WELL PAD TO PROPOSED ROAD SURVEY. FOLLOW ROAD SURVEY NORTHEAST APPROX. 544 FEET TO THE PROPOSED LUSK 27 FEDERAL #2 WELL PAD THEN NORTH APPROX. 1047 FEET TO THE SOUTHWEST CORNER OF THIS LOCATION.

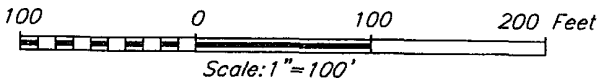

 PROVIDING SURVEYING SERVICES  
 SINCE 1946  
**JOHN WEST SURVEYING COMPANY**  
 412 N. DAL PASO  
 HOBBS, N.M. 88240  
 (505) 393-3117

**EDGE PETROLEUM OPERATING CO.**

SOUTHEAST LUSK 27 FEDERAL #5 WELL  
 LOCATED 1685 FEET FROM THE SOUTH LINE  
 AND 990 FEET FROM THE WEST LINE OF SECTION 27,  
 TOWNSHIP 19 SOUTH, RANGE 32 EAST, N.M.P.M.,  
 LEA COUNTY, NEW MEXICO.

Survey Date: 8/15/08	Sheet 1 of 1 Sheets	
W.O. Number: 08.11.1328	Dr By: AR	Rev 1:10/1/08
Date: 8/26/08	Disk: 08111328	Scale: 1"=100'

Exhibit C

# PECOS DISTRICT CONDITIONS OF APPROVAL

OPERATOR'S NAME:	Edge Petroleum Operating Company
LEASE NO.:	NM12412
WELL NAME & NO.:	Southeast Lusk 27 Federal No 5
SURFACE HOLE FOOTAGE:	1685' FSL & 990' FWL
BOTTOM HOLE FOOTAGE:	Same
LOCATION:	Section 27, T. 19 S., R 32 E., NMPM
COUNTY:	Lea County, New Mexico

## TABLE OF CONTENTS

Standard Conditions of Approval (COA) apply to this APD. If any deviations to these standards exist or special COAs are required, the section with the deviation or requirement will be checked below.

- General Provisions**
- Permit Expiration**
- Archaeology, Paleontology, and Historical Sites**
- Noxious Weeds**
- Special Requirements**
  - Lesser Prairie Chicken
  - Ground-level Abandoned Well Marker
- Construction**
  - Notification
  - Topsoil
  - Closed Loop System
  - Federal Mineral Material Pits
  - Well Pads
  - Roads
- Road Section Diagram**
- Drilling**
  - Secretary's Potash
- Production (Post Drilling)**
  - Well Structures & Facilities
  - Pipelines
- Closed Loop System/Interim Reclamation**
- Final Abandonment/Reclamation**

## **I. GENERAL PROVISIONS**

The approval of the Application For Permit To Drill (APD) is in compliance with all applicable laws and regulations: 43 Code of Federal Regulations 3160, the lease terms, Onshore Oil and Gas Orders, Notices To Lessees, New Mexico Oil Conservation Division (NMOCD) Rules, National Historical Preservation Act As Amended, and instructions and orders of the Authorized Officer. Any request for a variance shall be submitted to the Authorized Officer on Form 3160-5, Sundry Notices and Report on Wells.

## **II. PERMIT EXPIRATION**

If the permit terminates prior to drilling and drilling cannot be commenced within 60 days after expiration, an operator is required to submit Form 3160-5, Sundry Notices and Reports on Wells, requesting surface reclamation requirements for any surface disturbance. However, if the operator will be able to initiate drilling within 60 days after the expiration of the permit, the operator must have set the conductor pipe in order to allow for an extension of 60 days beyond the expiration date of the APD. (Filing of a Sundry Notice is required for this 60 day extension.)

## **III. ARCHAEOLOGICAL, PALEONTOLOGY & HISTORICAL SITES**

Any cultural and/or paleontological resource discovered by the operator or by any person working on the operator's behalf shall immediately report such findings to the Authorized Officer. The operator is fully accountable for the actions of their contractors and subcontractors. The operator shall suspend all operations in the immediate area of such discovery until written authorization to proceed is issued by the Authorized Officer. An evaluation of the discovery shall be made by the Authorized Officer to determine the appropriate actions that shall be required to prevent the loss of significant cultural or scientific values of the discovery. The operator shall be held responsible for the cost of the proper mitigation measures that the Authorized Officer assesses after consultation with the operator on the evaluation and decisions of the discovery. Any unauthorized collection or disturbance of cultural or paleontological resources may result in a shutdown order by the Authorized Officer.

## **IV. NOXIOUS WEEDS**

The operator shall be held responsible if noxious weeds become established within the areas of operations. Weed control shall be required on the disturbed land where noxious weeds exist, which includes the roads, pads, associated pipeline corridor, and adjacent land affected by the establishment of weeds due to this action. The operator shall consult with the Authorized Officer for acceptable weed control methods, which include following EPA and BLM requirements and policies.

## V. SPECIAL REQUIREMENT(S)

1. Timing Limitation Stipulation/Condition of Approval for Lesser Prairie-Chicken: Oil and gas activities including 3-D geophysical exploration, and drilling will not be allowed in lesser prairie-chicken habitat during the period from March 1st through June 15th annually. During that period, other activities that produce noise or involve human activity, such as the maintenance of oil and gas facilities, geophysical exploration other than 3-D operations, and pipeline, road, and well pad construction, will be allowed except between 3:00 am and 9:00 am. The 3:00 am to 9:00 am restriction will not apply to normal, around-the-clock operations, such as venting, flaring, or pumping, which do not require a human presence during this period. Additionally, no new drilling will be allowed within up to 200 meters of leks known at the time of permitting. Normal vehicle use on existing roads will not be restricted. Exhaust noise from pump jack engines must be muffled or otherwise controlled so as not to exceed 75 db measured at 30 ft. from the source of the noise.
2. Ground-level Abandoned Well Marker to avoid raptor perching: Upon the plugging and subsequent abandonment of the well, the well marker will be installed at ground level on a plate containing the pertinent information for the plugged well. For more installation details, contact the Carlsbad Field Office at 575-234-5972.

**Southeast Lusk 27 Federal # 5:** Closed loop System; V- Door East

## **VI. CONSTRUCTION**

### **A. NOTIFICATION**

The BLM shall administer compliance and monitor construction of the access road and well pad. Notify the Carlsbad Field Office at (575) 234-5972 at least 3 working days prior to commencing construction of the access road and/or well pad.

When construction operations are being conducted on this well, the operator shall have the approved APD and Conditions of Approval (COA) on the well site and they shall be made available upon request by the Authorized Officer.

### **B. TOPSOIL**

The operator shall stockpile the topsoil of the well pad. The topsoil shall not be used to backfill the reserve pit and will be used for interim and final reclamation.

### **C. Closed Loop System**

**Southeast Lusk 27 Federal # 5:** Closed loop System; V- Door East

Tanks are required for drilling operations: No Pits.

The operator shall properly dispose of drilling contents at an authorized disposal site.

### **D. FEDERAL MINERAL MATERIALS PIT**

If the operator elects to surface the access road and/or well pad, mineral materials extracted during construction of the reserve pit may be used for surfacing the well pad and access road and other facilities on the lease.

Payment shall be made to the BLM prior to removal of any additional federal mineral materials from any site other than the reserve pit. Call the Carlsbad Field Office at (575) 234-5972.

### **E. WELL PAD SURFACING**

Surfacing of the well pad is not required.

If the operator elects to surface the well pad, the surfacing material may be required to be removed at the time of reclamation.

The well pad shall be constructed in a manner which creates the smallest possible surface disturbance, consistent with safety and operational needs.

### **F. ON LEASE ACCESS ROADS**

**Road Width**

The access road shall have a driving surface that creates the smallest possible surface disturbance and does not exceed fourteen (14) feet in width. The maximum width of surface disturbance, when constructing the access road, shall not exceed thirty (30) feet.

**Surfacing**

Surfacing material is not required on the new access road driving surface. If the operator elects to surface the new access road or pad, the surfacing material may be required to be removed at the time of reclamation.

Where possible, no improvements should be made on the unsurfaced access road other than to remove vegetation as necessary, road irregularities, safety issues, or to fill low areas that may sustain standing water.

The Authorized Officer reserves the right to require surfacing of any portion of the access road at any time deemed necessary. Surfacing may be required in the event the road deteriorates, erodes, road traffic increases, or it is determined to be beneficial for future field development. The surfacing depth and type of material will be determined at the time of notification.

**Crowning**

Crowning shall be done on the access road driving surface. The road crown shall have a grade of approximately 2% (i.e., a 1" crown on a 14' wide road). The road shall conform to Figure 1; cross section and plans for typical road construction.

**Ditching**

Ditching shall be required on both sides of the road.

**Turnouts**

Vehicle turnouts shall be constructed on the road. Turnouts shall be intervisible with interval spacing distance less than 1000 feet. Turnouts shall be constructed on all blind curves. Turnouts shall conform to the following diagram:

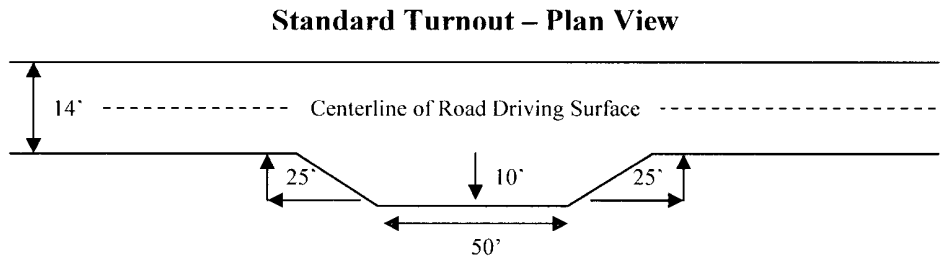

**Drainage**

Drainage control systems shall be constructed on the entire length of road (e.g. ditches, sidehill out sloping and insloping, lead-off ditches, culvert installation, and low water crossings).



A typical lead-off ditch has a minimum depth of 1 foot below and a berm of 6 inches above natural ground level. The berm shall be on the down-slope side of the lead-off ditch.

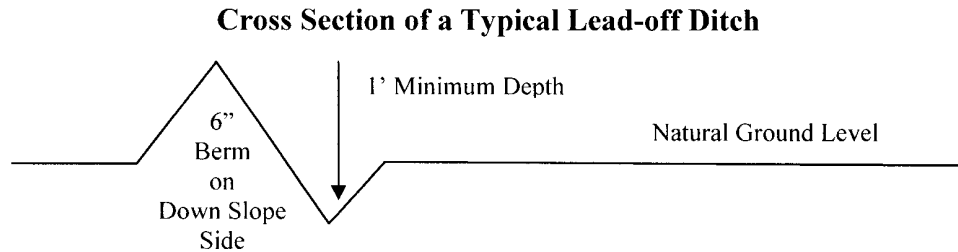

All lead-off ditches shall be graded to drain water with a 1 percent minimum to 3 percent maximum ditch slope. The spacing interval are variable for lead-off ditches and shall be determined according to the formula for spacing intervals of lead-off ditches, but may be amended depending upon existing soil types and centerline road slope (in %);

#### **Formula for Spacing Interval of Lead-off Ditches**

Example - On a 4% road slope that is 400 feet long, the water flow shall drain water into a lead-off ditch. Spacing interval shall be determined by the following formula:

$$400 \text{ foot road with } 4\% \text{ road slope: } \frac{400'}{4\%} + 100' = 200' \text{ lead-off ditch interval}$$

#### **Culvert Installations**

Appropriately sized culvert(s) shall be installed at the deep waterway channel flow crossing.

#### **Cattleguards**

An appropriately sized cattleguard(s) sufficient to carry out the project shall be installed and maintained at fence crossing(s).

Any existing cattleguard(s) on the access road shall be repaired or replaced if they are damaged or have deteriorated beyond practical use. The operator shall be responsible for the condition of the existing cattleguard(s) that are in place and are utilized during lease operations.

A gate shall be constructed and fastened securely to H-braces.

**Fence Requirement**

Where entry is required across a fence line, the fence shall be braced and tied off on both sides of the passageway prior to cutting.

The operator shall notify the private surface landowner or the grazing allotment holder prior to crossing any fence(s).

**Public Access**

Public access on this road shall not be restricted by the operator without specific written approval granted by the Authorized Officer.

Figure 1 – Cross Sections and Plans For Typical Road Sections

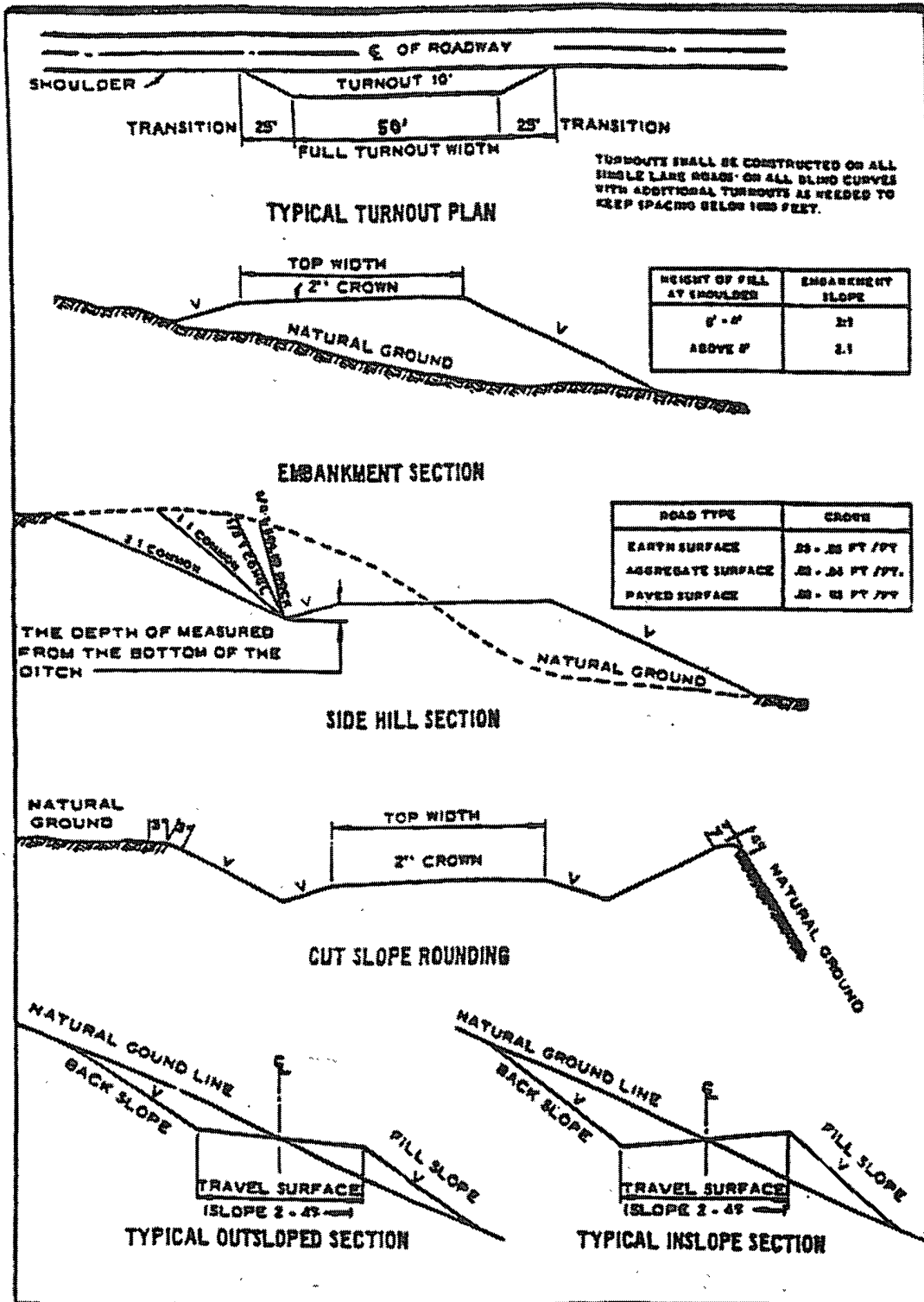

## VII. DRILLING

### A. DRILLING OPERATIONS REQUIREMENTS

The BLM is to be notified a minimum of 4 hours in advance for a representative to witness:

- a. Spudding well
- b. Setting and/or Cementing of all casing strings
- c. BOPE tests

**Lea County**

Call the Hobbs Field Station, 414 West Taylor, Hobbs NM 88240,  
(575) 393-3612

1. A Hydrogen Sulfide (H<sub>2</sub>S) Drilling Plan should be activated 500 feet prior to drilling into the Yates formation. **If Hydrogen Sulfide is encountered, please report measurements and formations to the BLM.**
2. Unless the production casing has been run and cemented or the well has been properly plugged, the drilling rig shall not be removed from over the hole without prior approval.
3. When floor controls are required, (3M or Greater) controls will be on the rig floor, unobstructed, readily accessible to the driller and will be operational at all times during drilling and/or completion activities. Rig floor is defined as the area immediately around the rotary table; the area immediately above the substructure on which the draw works are located, this does not include the dog house or stairway area.

### B. CASING

**Changes to the approved APD casing and cement program require submitting a sundry and receiving approval prior to work. Failure to obtain approval prior to work will result in an Incident of Non-Compliance being issued.**

**Centralizers required on surface casing per Onshore Order 2.III.B.1.f.**

**Wait on cement (WOC) time for a primary cement job will be a minimum 18 hours for a water basin, 24 hours in the potash area, or 500 pounds compressive strength, whichever is greater for all casing strings. Provide compressive strengths including hours to reach required 500 pounds compressive strength prior to cementing each casing string. See individual casing strings for details regarding lead cement slurry requirements.**

**No pea gravel permitted for remedial or fall back remedial without prior authorization from the BLM engineer.**

**Possible lost circulation in the Artesia Group and the Capitan Reef.  
Possible water flows in the Artesia and Salado Groups.**

1. The **16 inch** surface casing shall be set a **minimum of 25 feet into the Rustler Anhydrite and above the salt at approximately 890 feet** and cemented to the surface.
  - a. If cement does not circulate to the surface, the appropriate BLM office shall be notified and a temperature survey utilizing an electronic type temperature survey with a surface log readout will be used or a cement bond log shall be run to verify the top of the cement.
  - b. Wait on cement (WOC) time for a primary cement job is to include the lead cement slurry.**
  - c. Wait on cement (WOC) time for a remedial job will be a minimum of 4 hours after bringing cement to surface or 500 pounds compressive strength, whichever is greater.
  - d. If cement falls back, remedial action will be done prior to drilling out that string.
2. The minimum required fill of cement behind the **10-3/4 inch** intermediate casing is:
  - Cement to surface. If cement does not circulate see B.1.a, c-d above. **Casing to be set at approximately 2850 feet within the Seven Rivers formation and above the Bowers Member. Wait on cement (WOC) time for a primary cement job is to include the lead cement slurry due to Secretary's Potash.**
3. The minimum required fill of cement behind the **7-5/8 inch** intermediate casing is:
  - a. First stage to DV tool, cement shall:
    - Cement to circulate. If cement does not circulate, contact the appropriate BLM office, before proceeding with second stage cement job. **Casing to be set at approximately 4300 feet at the base of the Goat Seep Reef. Additional cement may be needed as excess cement calculates to 14%.**

**External Casing Packer and DV tool are to be set a minimum of 50 feet above the 10-3/4" casing shoe.**

b. Second stage above DV tool, cement shall:

- Cement to surface. If cement does not circulate, contact the appropriate BLM office. **Wait on cement (WOC) time for a primary cement job is to include the lead cement slurry due to protection for Capitan Reef.**

4. The minimum required fill of cement behind the 5-1/2 inch production casing is:

- Cement to surface. If cement does not circulate, contact the appropriate BLM office. **Additional cement will be required to circulate as excess calculated to a negative 8%.**

5. If hardband drill pipe is rotated inside casing, returns will be monitored for metal. If metal is found in samples, drill pipe will be pulled and rubber protectors which have a larger diameter than the tool joints of the drill pipe will be installed prior to continuing drilling operations.

### C. PRESSURE CONTROL

1. All blowout preventer (BOP) and related equipment (BOPE) shall comply with well control requirements as described in Onshore Oil and Gas Order No. 2 and API RP 53 Sec. 17.
2. The appropriate BLM office shall be notified a minimum of 4 hours in advance for a representative to witness the tests.
  - a. The tests shall be done by an independent service company.
  - b. The results of the test shall be reported to the appropriate BLM office.
  - c. All tests are required to be recorded on a calibrated test chart. A copy of the BOP/BOPE test chart and a copy of independent service company test will be submitted to the appropriate BLM office.
  - d. The BOP/BOPE test shall include a low pressure test from 250 to 300 psi. The test will be held for a minimum of 10 minutes if test is done with a test plug and 30 minutes without a test plug.

### D. DRILL STEM TEST

If drill stem tests are performed, Onshore Order 2.III.D shall be followed.

**WWI 111708**

## VIII. PRODUCTION (POST DRILLING)

### A. WELL STRUCTURES & FACILITIES

#### Placement of Production Facilities

Production facilities should be placed on the well pad to allow for maximum interim recontouring and revegetation of the well location.

#### Containment Structures

The containment structure shall be constructed to hold the capacity of the entire contents of the largest tank, plus 24 hour production, unless more stringent protective requirements are deemed necessary by the Authorized Officer.

#### Painting Requirement

All above-ground structures including meter housing that are not subject to safety requirements shall be painted a flat non-reflective paint color Shale Green, Munsell Soil Color Chart # 5Y 4/2

### B. PIPELINES

BLM Serial Number:

Company Reference:

Well # & Name:

#### STANDARD STIPULATIONS FOR SURFACE INSTALLED PIPELINES

**A copy of the APD and attachments, including stipulations, survey plat and/or map, will be on location during construction. BLM personnel may request to you a copy of your permit during construction to ensure compliance with all stipulations.**

Holder agrees to comply with the following stipulations to the satisfaction of the Authorized Officer:

1. The holder shall indemnify the United States against any liability for damage to life or property arising from the occupancy or use of public lands under this grant.
2. The holder shall comply with all applicable Federal laws and regulations existing or hereafter enacted or promulgated. In any event, the holder shall comply with the Toxic Substances Control Act of 1976 as amended, 15 USC 2601 et seq. (1982) with regards to any toxic substances that are used, generated by or stored on the right-of-way or on facilities authorized under this right-of-way grant. (See 40 CFR, Part 702-799 and especially, provisions on polychlorinated biphenyls, 40 CFR 761.1-761.193.) Additionally, any release of toxic substances (leaks, spills, etc.) in excess of the reportable quantity established by 40 CFR, Part 117 shall be reported as required by the Comprehensive Environmental Response, Compensation, and Liability Act, section 102b. A copy of any report required or requested by any Federal agency or State government as a result of a reportable release or spill of any toxic substances shall be furnished to the

authorized officer concurrent with the filing of the reports to the involved Federal agency or State government.

3. The holder agrees to indemnify the United States against any liability arising from the release of any hazardous substance or hazardous waste (as these terms are defined in the Comprehensive Environmental Response, Compensation and Liability Act of 1980, 42 U.S.C. 9601, et seq. or the Resource Conservation and Recovery Act, 42 U.S.C. 6901, et seq.) on the Right-of-Way (unless the release or threatened release is wholly unrelated to activity of the Right-of-Way holder's activity on the Right-of-Way), or resulting from the activity of the Right-of-Way holder on the Right-of-Way. This agreement applies without regard to whether a release is caused by the holder, its agent, or unrelated third parties.

4. The holder shall be liable for damage or injury to the United States to the extent provided by 43 CFR Sec. 2883.1-4. The holder shall be held to a standard of strict liability for damage or injury to the United States resulting from pipe rupture, fire, or spills caused or substantially aggravated by any of the following within the right-of-way or permit area:

- a. Activities of the holder including, but not limited to construction, operation, maintenance, and termination of the facility.
- b. Activities of other parties including, but not limited to:
  - (1) Land clearing.
  - (2) Earth-disturbing and earth-moving work.
  - (3) Blasting.
  - (4) Vandalism and sabotage.
- c. Acts of God.

The maximum limitation for such strict liability damages shall not exceed one million dollars (\$1,000,000) for any one event, and any liability in excess of such amount shall be determined by the ordinary rules of negligence of the jurisdiction in which the damage or injury occurred.

This section shall not impose strict liability for damage or injury resulting primarily from an act of war or from the negligent acts or omissions of the United States.

5. If, during any phase of the construction, operation, maintenance, or termination of the pipeline, any oil, salt water, or other pollutant should be discharged from the pipeline system, impacting Federal lands, the control and total removal, disposal, and cleaning up of such oil, salt water, or other pollutant, wherever found, shall be the responsibility of the holder, regardless of fault. Upon failure of the holder to control, dispose of, or clean up such discharge on or affecting Federal lands, or to repair all damages resulting therefrom, on the Federal lands, the Authorized Officer may take such measures as he



deems necessary to control and clean up the discharge and restore the area, including, where appropriate, the aquatic environment and fish and wildlife habitats, at the full expense of the holder. Such action by the Authorized Officer shall not relieve the holder of any responsibility as provided herein.

6. All construction and maintenance activity will be confined to the authorized right-of-way width of 25 feet.

7. No blading or clearing of any vegetation will be allowed unless approved in writing by the Authorized Officer.

8. The holder shall install the pipeline on the surface in such a manner that will minimize suspension of the pipeline across low areas in the terrain. In hummocky or dune areas, the pipeline will be "snaked" around hummocks and dunes rather than suspended across these features.

9. The pipeline shall be buried with a minimum of 24 inches under all roads, "two-tracks," and trails. Burial of the pipe will continue for 20 feet on each side of each crossing. The condition of the road, upon completion of construction, shall be returned to at least its former state with no bumps or dips remaining in the road surface.

10. The holder shall minimize disturbance to existing fences and other improvements on public lands. The holder is required to promptly repair improvements to at least their former state. Functional use of these improvements will be maintained at all times. The holder will contact the owner of any improvements prior to disturbing them. When necessary to pass through a fence line, the fence shall be braced on both sides of the passageway prior to cutting of the fence. No permanent gates will be allowed unless approved by the Authorized Officer.

11. In those areas where erosion control structures are required to stabilize soil conditions, the holder will install such structures as are suitable for the specific soil conditions being encountered and which are in accordance with sound resource management practices.

12. Excluding the pipe, all above-ground structures not subject to safety requirement shall be painted by the holder to blend with the natural color of the landscape. The paint used shall be a color which simulates "Standard Environmental Colors" – **Shale Green**, Munsell Soil Color No. 5Y 4/2; designated by the Rocky Mountain Five State Interagency Committee.

13. The pipeline will be identified by signs at the point of origin and completion of the right-of-way and at all road crossings. At a minimum, signs will state the holder's name, BLM serial number, and the product being transported. Signs will be maintained in a legible condition for the life of the pipeline.

14. The holder shall not use the pipeline route as a road for purposes other than routine

maintenance as determined necessary by the Authorized Officer in consultation with the holder. The holder will take whatever steps are necessary to ensure that the pipeline route is not used as a roadway.

15. Any cultural and/or paleontological resource (historic or prehistoric site or object) discovered by the holder, or any person working on his behalf, on public or Federal land shall be immediately reported to the authorized officer. Holder shall suspend all operations in the immediate area of such discovery until written authorization to proceed is issued by the authorized officer. An evaluation of the discovery will be made by the authorized officer to determine appropriate cultural or scientific values. The holder will be responsible for the cost of evaluation and any decision as to proper mitigation measures will be made by the authorized officer after consulting with the holder.

(March 1989)

## **IX. INTERIM RECLAMATION & RESERVE PIT CLOSURE**

### **A. INTERIM RECLAMATION**

If the well is a producer, interim reclamation shall be conducted on the well site in accordance with the orders of the Authorized Officer. The operator shall submit a Sundry Notices and Reports on Wells (Notice of Intent), Form 3160-5, prior to conducting interim reclamation.

During the life of the development, all disturbed areas not needed for active support of production operations should undergo interim reclamation in order to minimize the environmental impacts of development on other resources and uses.

The operators should work with BLM surface management specialists to devise the best strategies to reduce the size of the location. Any reductions should allow for remedial well operations, as well as safe and efficient removal of oil and gas.

During reclamation, the removal of caliche is important to increasing the success of revegetating the site. Removed caliche may be used for road repairs, fire walls or for building other roads and locations. In order to operate the well or complete workover operations, it may be necessary to drive, park and operate on restored interim vegetation within the previously disturbed area. Disturbing revegetated areas for production or workover operations will be allowed. If there is significant disturbance and loss of vegetation, the area will need to be revegetated. Communicate with the appropriate BLM office for any exceptions/exemptions if needed.

BLM Serial #:  
Company Reference:  
Well Name and Number:

Seed Mixture for LPC Sand/Shinnery Sites

The holder shall seed all disturbed areas with the seed mixture listed below. The seed mixture shall be planted in the amounts specified in pounds of pure live seed (PLS)\* per acre. There shall be no primary or secondary noxious weeds in the seed mixture. Seed will be tested and the viability testing of seed will be done in accordance with State law(s) and within nine (9) months prior to purchase. Commercial seed will be either certified or registered seed. The seed container will be tagged in accordance with State law(s) and available for inspection by the authorized officer.

Seed will be planted using a drill equipped with a depth regulator to ensure proper depth of planting where drilling is possible. The seed mixture will be evenly and uniformly planted over the disturbed area (smaller/heavier seeds have a tendency to drop the bottom of the drill and are planted first). The holder shall take appropriate measures to ensure this does not occur. Where drilling is not possible, seed will be broadcast and the area shall be raked or chained to cover the seed. When broadcasting the seed, the pounds per acre are to be doubled. The seeding will be repeated until a satisfactory stand is established as determined by the authorized officer. Evaluation of growth will not be made before completion of at least one full growing season after seeding.

Species to be planted in pounds of pure live seed\* per acre:

<u>Species</u>	<u>lb/acre</u>
Plains Bristlegrass	5lbs/A
Sand Bluestem	5lbs/A
Little Bluestem	3lbs/A
Big Bluestem	6lbs/A
Plains Coreopsis	2lbs/A
Sand Dropseed	1lbs/A

\*\*Four-winged Saltbush 5lbs/A

\* This can be used around well pads and other areas where caliche cannot be removed.

\*Pounds of pure live seed:

Pounds of seed x percent purity x percent germination = pounds pure live seed  
(Insert Seed Mixture Here)

## **X. FINAL ABANDONMENT & REHABILITATION REQUIREMENTS**

Upon abandonment of the well and/or when the access road is no longer in service the Authorized Officer shall issue instructions and/or orders for surface reclamation and restoration of all disturbed areas.

On private surface/federal mineral estate land the reclamation procedures on the road and well pad shall be accomplished in accordance with the private surface land owner agreement.