

District I
 PO Box 1980, Hobbs, NM 88241-1980
 District II
 811 S. 1st Street, Artesia, NM 88210-2834
 District III
 1000 Rio Brazos Rd., Aztec, NM 87410
 District IV
 2040 South Pacheco, Santa Fe, NM 87505

State of New Mexico
 Energy, Minerals & Natural Resources Department

Form C-101
 Revised October 18, 1994
 Instructions on back
 Submit to Appropriate District Office
 State Lease - 6 Copies
 Fee Lease - 5 Copies

OIL CONSERVATION DIVISION
 2040 South Pacheco
 Santa Fe, NM 87505

AMENDED REPORT

APPLICATION FOR PERMIT TO DRILL, RE-ENTER, DEEPEN, PLUGBACK, OR ADD A ZONE

¹ Operator name and Address Enron Oil & Gas Company P.O. Box 2267 Midland, TX 79702		² OGRID Number 7377
		³ API Number 30-025-34674
⁴ Property Code 24803	⁵ Property Name Concho "5" State Com	⁶ Well No. 1

⁷ Surface Location

UL or lot no.	Section	Township	Range	Lot. Idn	Feet from the	North/South Line	Feet from the	East/West line	County
I	5	24S	33E		2310	South	660	East	Lea

⁸ Proposed Bottom Hole Location If Different From Surface

UL or lot no.	Section	Township	Range	Lot. Idn	Feet from the	North/South Line	Feet from the	East/West line	County

⁹ Proposed Pool 1

¹⁰ Proposed Pool 2

Johnson Ranch Wolfcamp

Pitchfork Ranch

¹¹ Work Type Code N	¹² Well Type Code G	¹³ Cable/Rotary R	¹⁴ Lease Type Code S	¹⁵ Ground Level Elevation 3655
¹⁶ Multiple N	¹⁷ Proposed Depth 14,200'	¹⁸ Formation Wolfcamp	¹⁹ Contractor McVay	²⁰ Spud Date 8/15/99

²¹ Proposed Casing and Cement Program

Hole Size	Casing Size	Casing weight/foot	Setting Depth	Sacks of Cement	Estimated TOC
14-3/4"	11-3/4 H40	ST&C 42#	650	350 CL C	Surface
11"	8-5/8 J55	LT&C 32#	4000	1050 C Prem +	Surface
11"	8-5/8 HCK	LT&C 32#	5000	1050 C Prem +	Surface
7-7/8"	5-1/2 S95/P110	LT&C 17#	13000	1180 Prem	4500'
4-3/4"	2-7/8" N-80	6 5#	14200	135 Prem	12,300'

²² Describe the proposed program. If this application is to DEEPEN or PLUG BACK give the data on the present productive zone and proposed new productive zone. Describe the blowout prevention program, if any. Use additional sheets if necessary

11-3/4" - 200 sx Prem Plus, 3% Econolite, 2% Calcium Chloride, 0.25#/sx Flocele
 150 sx Prem Plus, 2% Calcium Chloride
 8-5/8" - 800 sx Interfill C, .25#/sx Flocele
 250 sx Premium Plus, 2% Calcium Chloride
 5-1/2" - 930 sx Premium, 3% Econolite, 5#/sx Salt (3%), .25#/sx Flocele
 250 sx Prem 50/50 Poz mix 'A', 2% Halliburton-Gel First 2%, 0.5% Halad-322, 0.2% HR-5
 2-7/8" - 135 sx Premium Cement, 0.3% Halad-344, 0.3% Halad-413, 0.3% Super CBL, 0.3% SCR-100
 BOP Diagram Attached.

Permit Expires 1 Year From Approval
 Date Unless Drilling Underway

²³ I hereby certify that the information given above is true and complete to the best of my knowledge and belief.

Signature:

Mike Francis

Printed name: **Mike Francis**

Phone: **(915)686-3714**

Title: **Agent**

Date: **8/10/99**

OIL CONSERVATION DIVISION

Approved by: **ORIGINAL SIGNED BY**

GARY WINK

Title: **FIELD REP. II**

Approval Date: **8-11-99**

Expiration Date:

51 C 5

Handwritten mark

District I
PO Box 1980, Hobbs, NM 88241-1980

District II
PO Drawer DD, Artesia, NM 88211-0719

District III
1000 Rio Brazos Rd., Aztec, NM 87410

District IV
PO Box 2088, Santa Fe, NM 87504-2088

State of New Mexico
Energy, Minerals & Natural Resources Department

OIL CONSERVATION DIVISION
PO Box 2088
Santa Fe, NM 87504-2088

Form C-102
Revised February 21, 1994
Instructions on back
Submit to Appropriate District Office
State Lease - 4 Copies
Fee Lease - 3 Copies

AMENDED REPORT

WELL LOCATION AND ACREAGE DEDICATION PLAT

*API Number 30-025-34674		*Pool Code 79335	*Pool Name Johnson Ranch Wolfcamp
*Property Code 24803	*Property Name CONCHO "5" STATE COM		*Well Number 1
*OGRID No. 7377	*Operator Name ENRON OIL & GAS COMPANY		*Elevation 3655

¹⁰ Surface Location

UL or lot no.	Section	Township	Range	Lot Idn	Feet from the	North/South line	Feet from the	East/West line	County
1	5	24-S	33-E		2310	SOUTH	660	EAST	LEA

¹¹ Bottom Hole Location If Different From Surface

UL or lot no.	Section	Township	Range	Lot Idn	Feet from the	North/South line	Feet from the	East/West line	County

*Dedicated Acres 320 319.47	*Joint or Infill	*Consolidation Code	*Order No.
--	------------------	---------------------	------------

NO ALLOWABLE WILL BE ASSIGNED TO THIS COMPLETION UNTIL ALL INTERESTS HAVE BEEN CONSOLIDATED OR A NON-STANDARD UNIT HAS BEEN APPROVED BY THE DIVISION

16				17 OPERATOR CERTIFICATION
				<p><i>I hereby certify that the information contained herein is true and complete to the best of my knowledge and belief.</i></p> <p><i>Mike Francis</i> Signature Mike Francis Printed Name Agent Title 8/10/99 Date</p>
	<p>ENRON OIL & GAS COMPANY CONCHO "5" STATE COM No. 1 LAT. = 32°14'44.9" LONG. = 103°35'16.5" Y = 453895 X = 730604</p>			18 SURVEYOR CERTIFICATION
	<p><i>I hereby certify that the well location shown on this plat was plotted from field notes of actual surveys made by me or under my supervision, and that the same is true and correct to best of my belief.</i></p> <p>AUGUST 6, 1999 Date of Survey</p> <p>Signature and Seal of Professional Surveyor: </p> <p>Certificate Number 8278</p>			

ENRON OIL & GAS COMPANY
Concho "5" State Com No. 1

Attachment I

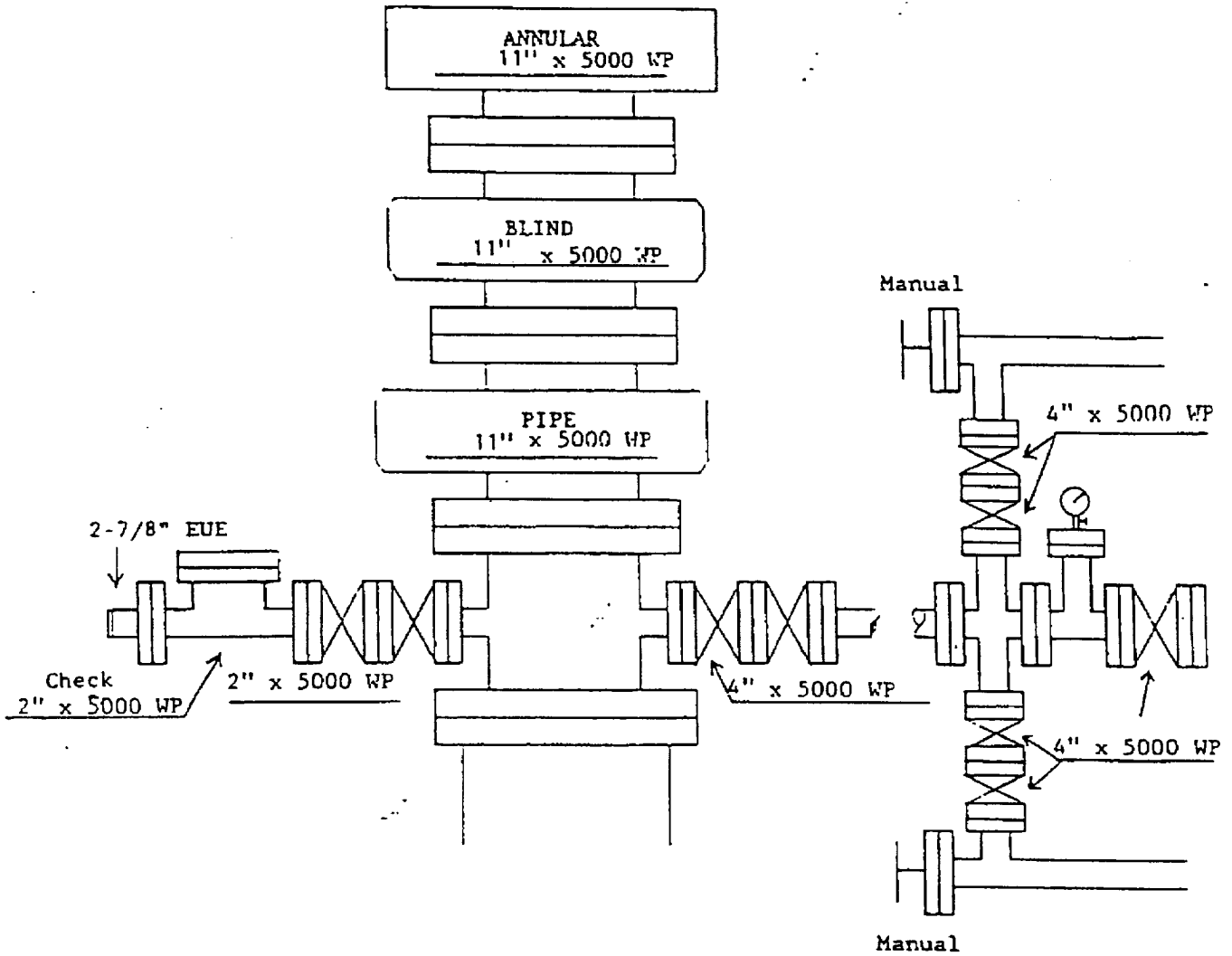

Nipple up this equipment at +/-650' and use until +/-12,800'

ENRON OIL & GAS COMPANY
Concho"5"State Com No. 1

Attachment II

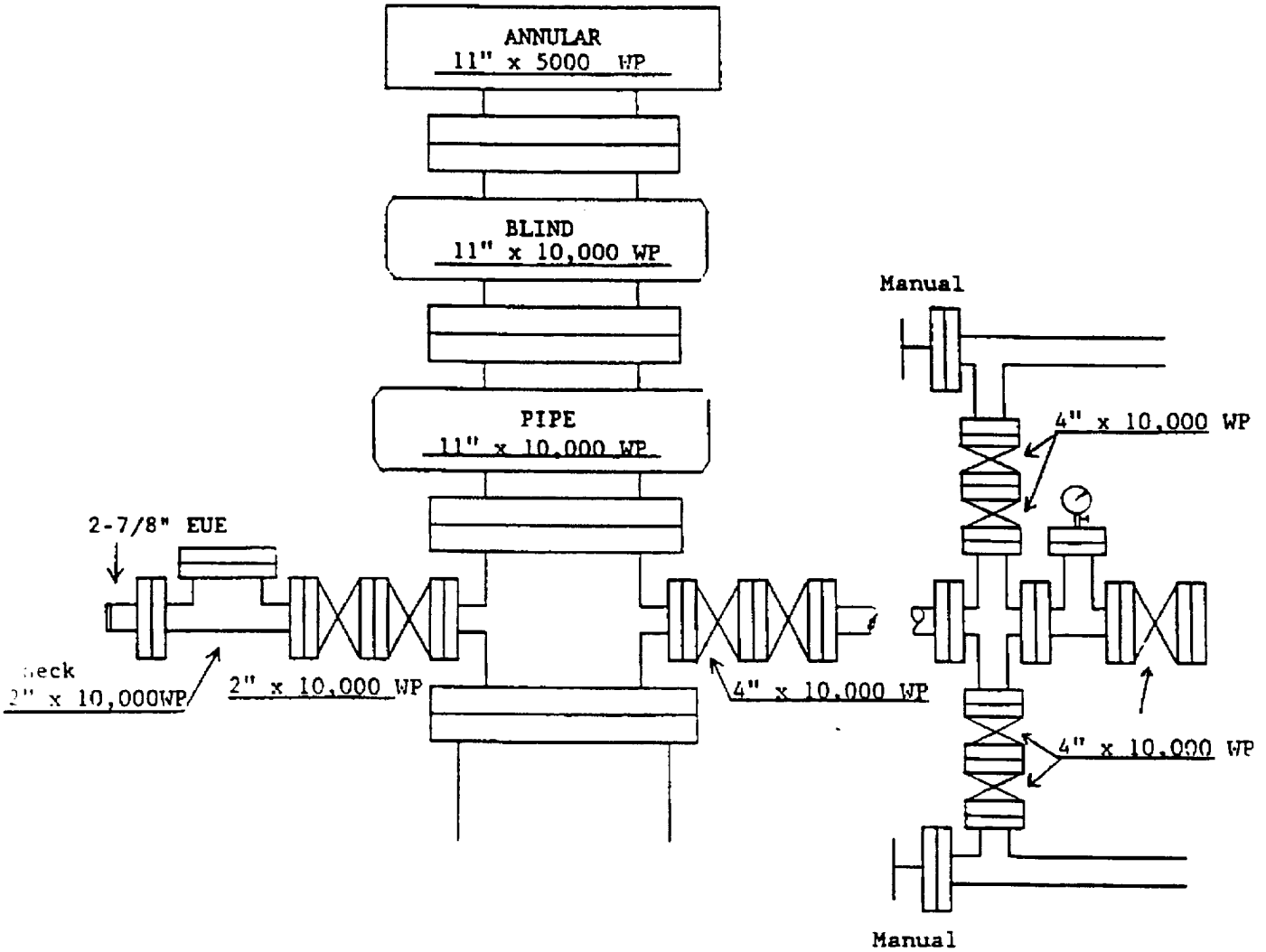

Nipple up this equipment at +/-12,800' and use until TD

ELF 10/2/14
ABOVE DATE DOES NOT
INDICATE WHEN
CONFIDENTIAL LOGS
WILL BE RELEASED