



STAGE 2 ABATEMENT PLAN

FORMER REVERSE
OSMOSIS REJECT
DISCHARGE FIELDS



HFSINCLAIR NAVAJO REFINING LLC

PROJECT NO.: 2367171004
DATE: APRIL 16, 2024

WSP USA ENVIRONMENT & INFRASTRUCTURE INC.
125 MONTOYA ROAD
EL PASO, TEXAS 79932

T: 915-585-2472

WSP.COM

SIGNATURES

PREPARED BY

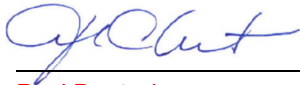

Paul Deutsch
Principal Scientist

APPROVED¹ BY



Brenda Barnes, PhD, PG
Lead Consultant, Senior Project Manager

WSP USA Environment & Infrastructure Inc. prepared this report solely for the use of the intended recipient, HollyFrontier Navajo Refining LLC, in accordance with the professional services agreement. The intended recipient is solely responsible for the disclosure of any information contained in this report. The content and opinions contained in the present report are based on the observations and/or information available to WSP USA Environment & Infrastructure Inc. at the time of preparation. If a third party makes use of, relies on, or makes decisions in accordance with this report, said third party is solely responsible for such use, reliance or decisions. WSP USA Environment & Infrastructure Inc. does not accept responsibility for damages, if any, suffered by any third party as a result of decisions made or actions taken by said third party based on this report. This limitations statement is considered an integral part of this report.

¹ Approval of this document is an administrative function indicating readiness for release and does not impart legal liability on to the Approver for any technical content contained herein. Technical accuracy and fit-for-purpose of this content is obtained through the review process. The Approver shall ensure the applicable review process has occurred prior to signing the document.



TABLE OF CONTENTS

- 1 BACKGROUND..... 1**
- 1.1 Facility Description 1**
- 1.2 Regulatory Background..... 1**
- 1.3 Current Status..... 2**
 - 1.3.1 Status of Discharge 2
 - 1.3.2 Soil Conditions 2
 - 1.3.3 Groundwater Conditions..... 3
 - 1.3.3.1 Potentiometric Surface 3
 - 1.3.3.2 Groundwater Concentrations..... 4
 - 1.3.3.3 Groundwater Remediation Recommendations 5
- 1.4 Stage 2 Abatement Plan Work Plan..... 7**
- 2 WELL INSTALLATION AND MONITORING PLAN UPDATES 8**
- 2.1 Well Installation and Sampling Procedures 8**
 - 2.1.1 Well Locations 8
 - 2.1.2 Well Installation Procedures 8
 - 2.1.2.1 Well Construction Methods..... 8
 - 2.1.2.2 Well Development..... 9
 - 2.1.3 Groundwater Sample Collection Procedures..... 9
 - 2.1.3.1 Sample Locations 9
 - 2.1.3.2 Groundwater Analytical Methods..... 10
 - 2.1.3.3 Groundwater Quality Assurance/Quality Control Samples ... 10
- 2.2 Groundwater Monitoring Plan..... 10**
- 3 EVALUATION OF REMEDIATION ALTERNATIVES 11**
- 3.1 Potential Remediation Alternatives..... 11**
 - 3.1.1 Soil Stabilization 11
 - 3.1.2 Phytotechnology Mechanisms 11
- 3.2 Phytoremediation Pilot Study Design 12**
 - 3.2.1 Soil and Site Suitability 12
 - 3.2.2 Potential Species..... 13
 - 3.2.3 Pilot Study Plot Design..... 13
 - 3.2.3.1 Irrigation Water Supply 14
 - 3.2.3.2 Final Design 14
- 3.3 Phytoremediation Pilot Study Implementation . 15**
- 4 SCHEDULE AND REPORTING 16**
- 4.1 Schedule..... 16**
- 4.2 Reporting..... 16**



5 PUBLIC NOTIFICATION 17

6 CLOSURE / POST-CLOSURE PLAN 18

REFERENCES 19

TABLES

Table 1 Summary of Groundwater Analytical Results Screened Using WQCC Standards

Table 2 Summary of Mann-Kendall Statistical Evaluation of COC Concentrations in Groundwater

FIGURES

Figure 1 Site Location Map

Figure 2 Former RO Reject Discharge Fields Locations

Figure 3 Former RO Reject Discharge Fields Monitoring Well & Soil Moisture Probe Locations

APPENDICES

Appendix A Vertical Distribution of Primary Soil COCs

Appendix B Shallow Saturated Zone Potentiometric Surface Maps and Critical Groundwater Screening Level Exceedance Maps for Constituents of Concern – Fall 2020, Spring 2021, Fall 2021, Spring 2022, Fall 2022

Appendix C Trend Plots of COCs 2013-2022 ProUCL Mann-Kendall Statistical Evaluation of COCs 2013-2022

Appendix D Draft Public Notification

Appendix E Cost Estimate for Financial Assurance Plan

1 BACKGROUND

1.1 FACILITY DESCRIPTION

HFSinclair Navajo Refining LLC (HFSNR) owns and operates the Artesia Refinery (Refinery) which is located in the City of Artesia, New Mexico (**Figure 1**). The Refinery has been in operation since the 1920s, runs a predominant slate of Permian Basin crudes that are gathered in west Texas and southeast New Mexico, and can also source a variety of crude oils from Cushing, Oklahoma, including Canadian crudes. The Refinery serves markets in the southwestern United States and northern Mexico.

HFSNR utilizes reverse osmosis (RO) to remove minerals and salts from fresh water prior to use in the refining process. The fresh water is supplied from a blend of publicly supplied water from the City of Artesia and fresh groundwater obtained from the Refinery's water supply wells. The treated water (permeate stream) is used in the Refinery process while the RO reject stream cannot be used in the Refinery process as it contains concentrated salts and minerals that do not pass through the RO membranes. Prior to January 24, 2019, this concentrated RO reject stream was discharged to the surface of two fields located northeast of the Refinery operations area (**Figure 2**). The RO reject discharge fields are covered with native grass and discharged water was allowed to percolate or evaporate in those permitted areas. The discharge was performed under the jurisdiction of the State of New Mexico Energy, Minerals and Natural Resource Department Oil Conservation Division (OCD) in accordance with Discharge Permit GW-028 (Permit), which was initially issued in October 1991. The Permit has subsequently been modified and renewed several times with the most recent renewal issued in August 2022 (OCD 2022).

1.2 REGULATORY BACKGROUND

When OCD renewed the Permit in 2017 (OCD 2017), it included a requirement that discharge of RO reject discharge stream to the surface cease upon operational completion of a Class I disposal well, but not later than October 31, 2018. An extension to the October 31, 2018 deadline was requested and approved by OCD due to delays in operational completion of the Class I disposal well (OCD 2018). The renewed Permit required characterization and abatement of vadose zone and groundwater contamination due to the historical discharge of RO reject fluid. The Permit stipulated that a plan for characterization and abatement of such contamination should be submitted within 60 days after cessation of discharge of RO reject fluid. The disposal well became operational on January 16, 2019, and the discharge of RO reject to the fields was discontinued on January 24, 2019. A Stage 1 Abatement Plan (AP) was submitted on March 21, 2019 (Wood 2019a), amended on May 24, 2019 (Wood 2019b) per OCD requests, and approved by OCD via email on June 7, 2019.

Implementation of the Stage 1 AP began in July 2019, and the final report of the activities was submitted to OCD on November 19, 2020 (Wood 2020). The Stage 1 AP included the following activities:

- Soil moisture monitoring to evaluate the moisture level in the vadose zone beneath both fields
- Analysis of constituents of concern (COCs) in soil samples collected during the installation of the soil moisture probes in both fields
- Installation of additional monitoring wells upgradient of the North RO reject field and downgradient of both the North and South RO reject fields
- Collection of shallow groundwater samples on a quarterly basis, for four quarters, from monitoring wells located upgradient, within, and downgradient of both fields
- Evaluation of the soil moisture, soil analytical, and groundwater analytical data

The recommendations made in the final Stage 1 AP report included:

- Continued groundwater monitoring:
- Installation of additional downgradient wells:
 - One well approximately 350 feet northeast of MW-119 to provide downgradient monitoring of the North RO reject discharge field
 - One well approximately 1,000 feet east of RW-18A to provide additional downgradient monitoring of the South RO reject discharge field
- Semiannual gauging and sampling of the wells included in this study, with the addition of the two new wells recommended downgradient of MW-119 and RW-18A along with inclusion of MW-134 for additional downgradient monitoring of the South RO reject discharge field.
- Analysis of groundwater samples for the following analytes, at a minimum (additional analytes may be required for the facility-wide groundwater monitoring program):
 - Fluoride
 - Sulfate
 - Total Dissolved Solids (TDS) – for the South RO reject discharge field only
 - Uranium – for the South RO reject discharge field only
- Inclusion of the analytical data in the annual facility-wide monitoring report.
- Preparation and submittal of this Stage 2 Abatement Plan (Stage 2 AP) in accordance with NMAC 20.6.2.4106.D, following approval of this Stage 1 AP. The Stage 2 AP will evaluate remedial alternatives focused on removal of fluoride (and potentially other inorganics) from shallow soil and/or groundwater or removal of the potential infiltration pathway. The Stage 2 AP will be submitted within 60 days of receipt of approval of the Stage 1 AP.

OCD approved the Stage 1 AP in a letter dated August 22, 2022 (OCD 2022) and requested submittal of this Stage 2 AP within 60 days.

1.3 CURRENT STATUS

1.3.1 STATUS OF DISCHARGE

Discharge of RO reject to the fields was discontinued on January 24, 2019. The moisture probes remain in place but have not been operated following completion of the Stage 1 AP. Some vegetation is present on the fields, but no cultivation and or irrigation is being conducted. The vegetation in the fields has not been cut or removed following completion of the Stage 1 AP. The surrounding berms that prevented runoff from the fields remain in place and thus rainfall that falls within the fields either evaporates or infiltrates.

1.3.2 SOIL CONDITIONS

No additional soil samples have been collected following completion of the Stage 1 AP. Table 1 of the Stage 1 AP presented a summary of the soil analytical data and stated the following COCs were present in the soil samples within the two RO reject discharge fields above the Soil Screening Levels (SSLs) published by the New Mexico Environment Department in 2019:

- Arsenic (exceeded the soil-leaching-to-groundwater SSL)
- Cobalt (exceeded the soil-leaching-to-groundwater SSL)
- Iron (exceeded the soil-leaching-to-groundwater SSL)
- Manganese (exceeded the construction worker noncancer SSL)

Additionally, the following COCs were present in the soil leachate samples (analyzed by the Synthetic Precipitation Leaching Procedure) at concentrations above the Water Quality Control Commission (WQCC) standards found at NMAC 20.6.2.3103:

- Iron
- Fluoride
- Sulfate

Although the concentrations of Arsenic and Cobalt in soil exceed the soil-leaching-to-groundwater SSLs, the SPLP results are below the WQCC standards. Thus, no further action is recommended for these COCs in soil.

Based on the information presented in the Stage 1 AP, remediation is recommended for the following soil COCs:

- Iron
- Manganese
- Fluoride
- Sulfate

Appendix A contains graphs of the vertical distribution of the primary soil COCs listed in Section 1.3.2 of the Stage 2 AP (Arsenic, Cobalt, Iron, Manganese, Fluoride, and Sulfate). As can be seen in these graphs, 1) the concentrations of soil COCs generally decrease with depth in the soil samples collected during the installation of the monitoring wells, and 2) at most well locations the concentrations from samples collected deeper than 10 feet below ground surface (bgs) are lower than the concentrations from samples collected between the ground surface and 10 feet bgs.

The soil-leaching-to-groundwater SSL (Cw DAF20 SSL), if applicable and in range, is shown on the vertical profile graphs in **Appendix A**. The soil analytical data from depths greater than 10 feet bgs, collected during installation of monitoring wells within the former RO reject discharge fields, indicate that reported concentrations do not exceed the Cw DAF20 SSL for Cobalt, Manganese, and Fluoride. Only one sample collected from depths greater than 10 feet bgs exceed the Cw DAF20 SSL for Arsenic in each of the two former RO reject discharge fields (MW-116 in the South field and MW-117 in the North field). Several samples collected from depths greater than 10 feet bgs exceed the Cw DAF20 SSL for Iron; however, the concentrations of Iron in groundwater samples collected from wells located within the two former RO reject discharge fields do not exceed the WQCC standard, indicating that Iron is not leaching from the soil column within the fields at rates high enough to negatively impact the groundwater. There is no Cw DAF20 SSL established for Sulfate.

The soil analytical results indicate that the bulk of the soil COC loading is within the upper 10 feet of the soil column within the two former RO reject discharge fields. The vadose zone is believed to be limited to a range of less than 16 feet bgs based on semiannual groundwater level measurements following cessation of discharge, which range from 8 to 16 feet bgs (note that the total well depth is greater to ensure capture of groundwater during periods of fluctuation).

Evaluation of soil remediation alternatives is presented in Section 3 of this Stage 2 AP.

1.3.3 GROUNDWATER CONDITIONS

1.3.3.1 POTENTIOMETRIC SURFACE

The shallow groundwater mound that was present beneath the fields during the discharge of RO reject water has dissipated following cessation of the discharge. A copy of the semiannual potentiometric surface maps created using groundwater gauging data gathered after the Stage 1 AP was completed (fall of 2020 and for both the spring and fall of 2023) are provided in **Appendix B**. These maps were submitted in the annual groundwater monitoring reports (TRC 2021, TRC 2022, TRC 2023, TRC 2024).

Semiannual groundwater level measurements from 2019 (following cessation of discharge) through 2023 indicate that the vadose zone is limited to a range of 8 to 16 feet bgs.

1.3.3.2 GROUNDWATER CONCENTRATIONS

The monitoring wells evaluated in the Stage 1 AP remain in place and those wells that were previously included in the facility-wide monitoring program have continued to be sampled and analyzed for COCs included in that program. However, monitoring wells MW-140 through MW-143 have not been sampled since June of 2020 as they are not currently included in the facility-wide monitoring program, as stated in the Stage 1 AP.

A copy of the isopleth maps generated using groundwater sampling data obtained after the Stage 1 AP was completed (fall of 2020 and for both the spring and fall of 2021) and submitted in annual groundwater monitoring reports (TRC 2021 and TRC 2022) are provided in **Appendix B**. Spring and fall 2022 isopleth maps are also provided in **Appendix B**. The isopleth maps provided include only those COCs that are included in the facility-wide monitoring plan that were also addressed in the Stage 1 AP, which are:

- Arsenic
- Chloride
- Fluoride
- Sulfate
- TDS
- Nitrate/Nitrite

OCD clarified that the future groundwater monitoring associated with the former RO reject discharge fields must include the COCs that exceed the WQCC standards and that the alternate standards proposed for select COCs in the Stage 1 AP are not approved.

Table 1 contains analytical data for total and dissolved metals and water quality parameters that were evaluated in the Stage 1 AP, for the period of 2019 through 2022, compared to the current WQCC standards. This table is similar to Table 4 of the Stage 1 AP, with the addition of data from the five subsequent sampling events. The total metals concentrations are provided for comparison purposes; however, the dissolved metals concentrations were used in the determination of COCs to be addressed in this Stage 2 AP. It should be noted that groundwater samples have historically been analyzed for Nitrate and Nitrite combined but the WQCC standards have been defined separately for Nitrate and Nitrite. The lower standard for Nitrite of 1.0 mg/L was used for the screening presented in **Table 1**.

Plots of concentration versus time for the COCs evaluated during the Stage 1 AP have been updated and are provided in **Appendix C**. The plots are divided by field (North or South) and are grouped into wells located upgradient, within, and downgradient of the fields. The plots are very similar to the plots provided in the Stage 1 AP with the addition of data collected between the end of the Stage 1 AP and 2022, and the revision of the Nitrate/Nitrite screening standard.

The data presented in **Table 1** and the plots provided **Appendix C** indicate the following:

- Dissolved Arsenic was reported at concentrations above the WQCC standard in two samples from MW-29 (upgradient of the South RO reject discharge field) but has not been reported at concentrations above the standard in any of the wells located within the two fields since October 2019. No further action is recommended for dissolved Arsenic in groundwater beneath the RO reject discharge fields. Arsenic is included in the facility-wide groundwater monitoring program and will continue to be analyzed under that program.
- Dissolved Boron is not included in the facility-wide monitoring program for any well except MW-55 (upgradient of the North RO reject discharge field) and thus little data is available since October 2020. Additional monitoring of dissolved Boron is recommended prior to determining if further action is required.
- Dissolved Cobalt concentrations from the samples collected from the wells associated with both RO reject discharge fields were all below the WQCC standard. No further action is recommended for dissolved Cobalt in groundwater beneath the RO reject discharge fields.
- Dissolved Iron is not detectable in the majority of the samples collected from wells associated with both RO reject discharge fields. The sample collected from MW-29 (upgradient of the South RO reject discharge field) in October 2019 contained dissolved Iron above the WQCC standard; however, the four subsequent samples collected from this well were either not detectable for dissolved Iron or

contained a concentration below the standard. No further action is recommended for dissolved Iron in groundwater beneath the RO reject discharge fields.

- Dissolved Lead concentrations from the samples collected from the wells associated with both RO reject discharge fields were all below the WQCC standard. No further action is recommended for dissolved Lead in groundwater beneath the RO reject discharge fields.
- Dissolved Manganese concentrations in MW-29 and MW-56 (upgradient of the South RO reject discharge field), MW-114 (within the South RO reject discharge field), and MW-125 (downgradient of the South RO reject discharge field) are above the WQCC standard. Concentrations of dissolved Manganese in the wells within and downgradient of the North RO reject discharge field are below the WQCC standard. Additional evaluation is recommended to determine if further action is required.
- Dissolved Uranium is not included in the facility-wide monitoring program for any well except MW-55 (upgradient of the North RO field) and thus little data is available since October 2020. Concentrations of Uranium reported in the samples collected in 2021 and 2022 from MW-55 have decreased and are below the WQCC standard. Additional monitoring of dissolved Uranium is recommended prior to determining if further action is required.
- Chloride concentrations generally appear to be decreasing in samples collected from wells within the two fields and in MW-55, which is upgradient of the North RO reject discharge field. The concentrations of Chloride appear to be increasing in samples collected from MW-29 and appear to be decreasing in samples collected from MW-56, both of which are upgradient of the South RO reject discharge field. Chloride remains a COC within groundwater beneath the fields.
- Fluoride concentrations generally appear to be decreasing in samples collected from wells within both fields. Fluoride remains a COC within groundwater beneath the fields.
- Nitrate/Nitrite concentrations generally appear to be decreasing in samples collected from wells within both fields, with only one well (MW-118 inside the North RO reject discharge field) containing a concentration above the WQCC standard for Nitrite. None of the reported concentrations exceed the WQCC standard for Nitrate. Future samples will be analyzed for Nitrate and Nitrite separately. Nitrite remains a COC within groundwater beneath the fields.
- Sulfate and TDS exceed the respective WQCC standards in more than one of the samples collected from one or more of the wells located upgradient, within, and downgradient of the two RO reject discharge fields between the cessation of discharge and the fall 2022 sampling event. Concentrations of Sulfate and TDS generally appear to be stable or decreasing slightly in samples collected from wells within the two fields. Sulfate and TDS remain COCs within groundwater beneath the fields.

A statistical evaluation of the groundwater concentrations of COCs recommended for further evaluation (Chloride, Fluoride, Nitrite, Sulfate, TDS, Boron, Manganese, and Uranium) was performed to determine whether there is a statistically significant trend in concentrations following the cessation of discharge of the RO reject stream to the fields. The statistical evaluation software ProUCL 5.2 (EPA 2022) was used to perform Mann-Kendall trend analyses of the data. **Table 2** presents a summary of the statistical evaluation of the concentrations reported between 2019 and 2021. **Appendix C** contains printouts from the ProUCL program for each well and each analyte.

1.3.3.3 GROUNDWATER REMEDIATION RECOMMENDATIONS

Soil remediation (phytoremediation) is proposed to reduce the mass of COCs in the shallow soil, thus removing or reducing the potential for leaching of soil COCs into shallow groundwater. Additionally, the phytoremediation will also uptake water from the shallow soil to further reduce infiltration and thus leaching of soil COCs to groundwater. Natural attenuation of groundwater COCs will continue to occur as the soil remediation progresses.

The following recommendations for groundwater are based on the current data and the updated evaluations presented in this section:

- Dissolved Arsenic has been present at concentrations above the WQCC standard in MW-29 (upgradient of the South RO reject discharge field). Although concentrations of dissolved Arsenic do not exceed the WQCC standard in samples from the wells within the field, semiannual monitoring of dissolved Arsenic within and downgradient of the fields is recommended for a period of three (3) years to confirm natural attenuation of this COC.

- Dissolved Boron has inadequate data to determine statistically significant trends for the period of 2019 through 2022 since this COC is not included in the facility-wide monitoring program for most of the wells. However, the most recent concentrations of dissolved Boron in the wells within both fields were below the WQCC standard. Semiannual monitoring of dissolved Boron in wells within and downgradient of the fields is recommended for a period of three (3) years to confirm natural attenuation of this COC.
- Dissolved Iron has been present at concentrations above the WQCC standard in MW-29 (upgradient of the South RO reject discharge field). Although concentrations of dissolved Iron do not exceed the WQCC standard in samples from the wells within the field, semiannual monitoring of dissolved Iron within and downgradient of the fields is recommended for a period of three (3) years to confirm natural attenuation of this COC.
- Dissolved Manganese is not currently present at concentrations above the WQCC standard in wells associated with the North RO reject discharge field. Dissolved Manganese is present at concentrations above the WQCC standard in MW-29 (upgradient of South RO reject discharge field) and MW-114 (near the former discharge point into the South RO reject discharge field). Dissolved Manganese concentrations are an order of magnitude below the standard in wells MW-115 and MW-116 (within the South RO reject discharge field). Semiannual monitoring of dissolved Manganese in wells within and downgradient of the fields is recommended for a period of three (3) years to confirm natural attenuation of this COC.
- Dissolved Uranium has inadequate data to determine statistically significant trends for the period of 2019 through 2022 since this COC is not included in the facility-wide monitoring program for most of the wells. Semiannual monitoring of dissolved Uranium in wells within and downgradient of the fields is recommended for a period of three (3) years to confirm natural attenuation of this COC.
- Chloride concentrations in wells associated with the North RO reject discharge field are statistically decreasing, except for MW-117 (near the former discharge point). Chloride concentrations in wells associated with the South RO reject discharge field show no statistically significant trend, but the concentrations from wells within the field show an overall decrease in concentrations. Natural attenuation of Chloride appears to be occurring in groundwater beneath the fields; however, recent increases in Chloride upgradient of the South RO reject discharge field appear to have resulted in a recent increase in Chloride in MW-114. Semiannual monitoring of Chloride in wells associated with the fields is recommended to evaluate natural attenuation following implementation of soil remediation and source removal.
- Fluoride concentrations in wells associated with both fields show either a decreasing or no statistically significant trend. Semiannual monitoring of Fluoride in wells associated with the fields is recommended to evaluate natural attenuation following implementation of soil remediation and source removal.
- Nitrate/Nitrite concentrations in wells associated with both fields are currently below the WQCC standard for Nitrite with the exception of the most recent concentration reported for MW-118 (within the North RO reject discharge field). No statistically significant trends were determined for the period of 2019 to 2022 with the exception of MW-55 (upgradient of the North RO reject discharge field), which has a decreasing trend. Semiannual monitoring of Nitrite and Nitrate, separately, in wells associated with the fields is recommended to confirm natural attenuation following implementation of soil remediation and source removal.
- Sulfate concentrations in wells associated with both fields show either a decreasing or no statistically significant trend. Semiannual monitoring of Sulfate in wells associated with the fields is recommended to evaluate natural attenuation following implementation of soil remediation and source removal.
- TDS concentrations in wells associated with both fields show either a decreasing or no statistically significant trend. Semiannual monitoring of TDS in wells associated with the fields is recommended to evaluate natural attenuation following implementation of soil remediation and source removal.

1.4 STAGE 2 ABATEMENT PLAN

Section 2 of this Stage 2 AP provides detailed information regarding the installation of additional downgradient monitoring wells recommended by the Stage 1 AP and approved by OCD as well as the future groundwater monitoring plan for wells associated with the RO reject discharge fields. The groundwater monitoring results will be used to evaluate the effectiveness of soil remediation and natural attenuation of groundwater COCs.

Section 3 summarizes an evaluation of remediation alternatives to address both soil and groundwater. The recommended remediation approach includes phytoremediation of shallow soils through the use of vegetation to reduce infiltration and remove COCs from the soil, which should enhance the natural attenuation of inorganic COCs in groundwater beneath the fields. Section 3 provides details on implementation of a phytoremediation pilot study to select a plant species most likely to meet the remediation goals, including development of irrigation and fertilization schedules to enhance vegetation health. The pilot study will be performed throughout both fields. Following completion of the pilot study, recommendations will be made to amend the Stage 2 AP, as necessary.

Section 4 provides a schedule for implementation of the Stage 2 AP and reports that will be submitted under this plan.

Section 5 includes a public notification proposal, as required by NMAC 20.6.2.4108.B and NMAC 20.6.2.4108.C.

Section 6 provides a financial assurance plan to conduct the actions described in this Stage 2 AP, as required by NMAC 20.6.2.4104.C.

2 WELL INSTALLATION AND MONITORING PLAN UPDATES

This section described the locations and methods for installation of additional monitoring wells described in the Stage 1 AP as well as the changes to the facility-wide monitoring program required.

2.1 WELL INSTALLATION AND SAMPLING PROCEDURES

2.1.1 WELL LOCATIONS

The Stage 1 AP recommended the installation of two additional shallow groundwater monitoring wells, as follows:

- One well approximately 350 feet northeast of MW-119 to provide downgradient of the North RO reject discharge field
- One well approximately 1,000 feet east of RW-18A to provide additional downgradient monitoring of the South RO reject discharge field

Figure 3 shows the recommended locations for these two wells. The actual locations of the wells will depend on subsurface utility clearance. If subsurface utilities require the location to be moved beyond a 50-foot radius of the planned location, OCD will be notified prior to well installation.

2.1.2 WELL INSTALLATION PROCEDURES

The installation of monitoring wells will be performed by a driller licensed in New Mexico, using hollow-stem drilling methods. The driller will be directed by an experienced geologist or environmental scientist.

2.1.2.1 WELL CONSTRUCTION METHODS

The monitoring wells will be installed within the shallow saturated zone. The depth of the wells is anticipated to be between 20 to 30 ft bgs, based on previously installed monitoring wells in the area. The minimum diameter of the borings will be approximately 8 inches to allow for the installation of 2-inch diameter PVC well casings. Each monitoring well will consist of a bottom cap, a section of 0.010-inch slotted well screen, and solid casing extending to the surface. The well screens for these monitoring wells will extend to 5 ft above the observed capillary zone. If no obvious capillary zone is present, the well screen will extend to within 5 ft of the ground surface. Well materials, including end caps, casings, and screens, will have threaded connections. Well construction materials will be kept wrapped in original packaging or plastic sheeting until used.

The monitoring well casings will be extended from the top of the well screen to 3 ft above the ground surface. An 8/16-grade sand pack will be placed in the annular space to three feet above the screened interval, and a 2-ft bentonite seal placed on top of the sand pack. A grout seal will be placed from the bentonite seal to the surface. The wells will be completed with locking steel protective casings set into a 4-ft by 4-ft by 4-inch thick concrete pad. Protective bollards will be placed around the wells, as deemed necessary by HFSNR and as space allows. The concrete pads will be approximately one inch higher than the surrounding surface and the concrete will be sloped from the protective casings to the surrounding surface. A locking J-plug cap will be placed in the casings inside the protective casing.

An experienced geoscientist or environmental scientist will observe the installation and construction of the monitoring wells, and will record measurements of various well dimensions, including distance from the ground surface to the:

- Bottom of the well
- Top of the sand pack

- Top of the bentonite seal
- Top of the screen
- Top of the well casing

The field measurements will be included in the field logbook and on the final well completion logs. The wells will be surveyed as described below.

2.1.2.2 WELL DEVELOPMENT

The monitoring wells will be developed through bailing and/or pumping to remove fine-grained materials accumulated in the sand pack and well casing until the bottom of the well casing can be reached. Conductivity, pH, dissolved oxygen (DO), oxidation-reduction potential (ORP), turbidity, and temperature of the purged groundwater will be monitored throughout the development process using a multi-parameter water meter. The development process will be considered complete after at least 4 of the 6 parameters stabilize (i.e., less than 10 percent variation between three consecutive readings) and at least three well casing volumes are removed. The measurements and equipment used to make the measurements will be recorded in the field logbook. Equipment will be calibrated following the manufacturer's recommendations and the calibration results will be recorded in the field logbook.

The volume of purged fluids will be recorded in the field logbook. Fluids produced during development will be collected and disposed of in the refinery wastewater treatment system, upstream of the oil-water separator.

Following well development, the depth to water and total depth of each well will be measured from the top of casing and will be recorded in the field logbook. Depth to water will be measured using a battery-operated water level meter. Although no phase-separated hydrocarbons (PSH) are expected to be present in these locations, if PSH is observed during well installation or development, the depth to water and PSH will be measured using a battery-operated oil/water interface probe. The model of meter(s) used will be recorded in the field logbook.

2.1.3 GROUNDWATER SAMPLE COLLECTION PROCEDURES

2.1.3.1 SAMPLE LOCATIONS

Groundwater samples will then be collected semiannually, during the routine facility-wide monitoring events, the from the following wells:

- North RO Reject Discharge Field:
 - Upgradient: MW-55, MW-140, MW-141
 - Within Field: MW-117, MW-118, MW-119
 - Downgradient: MW-142, MW-143, new well northeast of MW-119 (well number to be determined)
- South RO Reject Discharge Field:
 - Upgradient: MW-29, MW-40, MW-56
 - Within Field: MW-114, MW-115, MW-116
 - Downgradient: MW-125, RW-18A, MW-144, new well east of RW-18A (well number to be determined)

The locations of the monitoring wells associated with the former RO reject discharge fields are shown in **Figure 3**.

Low-flow sampling procedures, as described in the NMED Position Paper "Use of Low-Flow and Other Non-Traditional Sampling Techniques for RCRA Compliant Groundwater Monitoring" (NMED 2001), will be used to collect the groundwater sample. Low-flow purging will be continued until the field measurements of at least 4 of the 6 water quality parameters, including conductivity, pH, DO, ORP, turbidity, and temperature, stabilize (less than 10 percent variation for three consecutive readings). Equipment used to monitor water quality parameters will be calibrated following the manufacturer's recommendations, and the type (make and model) of equipment used and the calibration results will be recorded in the field logbook. Purge parameter readings will be documented in the field sampling logbook and will be included in the well installation report.

Dedicated tubing will be used in each well to prevent the potential for cross-contamination. Following completion of purging, groundwater samples will be collected directly into the laboratory-provided sample containers. Disposable filters will be used to collect samples that will be analyzed for dissolved metals. The samples that do not require field filtering will be collected first, then the filter will be attached to the tubing to collect the dissolved metals sampled. The filters will be removed from the tubing prior to placing it into the well casing. Used filters will be disposed of as trash in appropriate containers within the refinery.

Sample containers will be labeled and placed into appropriate containers (coolers) with ice for shipment to the analytical laboratory under proper chain of custody.

2.1.3.2 GROUNDWATER ANALYTICAL METHODS

The groundwater samples will be analyzed for the following COCs and methods for the purposes of the Stage 2 AP:

- Dissolved (field-filtered) metals by Methods 6010 or 6020:
 - Arsenic
 - Boron
 - Iron
 - Manganese
 - Uranium
- Chloride by Method 300 or 9056
- Fluoride by Method 300 or 9056
- Nitrate by Method 300 or 9056
- Nitrite by Method 300 or 9056
- Sulfate by Method 300 or 9056
- TDS by Method 2540

Additional analyses will be included as required for the facility-wide monitoring program.

The laboratory will be provided the screening standards for groundwater samples and will make every possible attempt to maintain method detection limits that are less than or equal to the screening standards. It should be noted that this may not be possible if a sample contains constituents at concentrations high enough to require sample dilution.

2.1.3.3 GROUNDWATER QUALITY ASSURANCE/QUALITY CONTROL SAMPLES

Quality assurance/quality control (QA/QC) samples will be collected to monitor the validity of the groundwater sample collection procedures. The following samples will be collected for QA/QC purposes:

- Field duplicates will be collected at a rate of 10 percent, or 1 field duplicate for every 10 groundwater samples, with a minimum of 1 field duplicate sample to be collected during the implementation of this work plan. Field duplicates will be analyzed for the same constituents as the parent sample.
- Equipment blanks will be collected from non-dedicated sampling apparatus at a frequency of 5 percent, or 1 equipment blank for every 20 groundwater samples collected, with a minimum of one equipment blank per day. Equipment blank samples will be analyzed for the same constituents as the sample associated with the equipment blank (sample collected immediately prior to the equipment blank). When dedicated sampling materials are used, such as dedicated tubing, no equipment blank samples are required.
- Trip blanks will not be required for the RO reject discharge fields groundwater monitoring since none of the COCs included volatile organic compounds (VOCs).

2.2 GROUNDWATER MONITORING PLAN

The facility-wide groundwater monitoring work plan will be updated to reflect the groundwater sampling outlined in Section 2.1. Groundwater samples will be collected and analyzed semiannually as described in Section 2.1.3 for a period of at least 3 years to determine if the COC concentrations continue to attenuate following cessation of discharge of the RO reject stream to the fields.

3 EVALUATION OF REMEDIATION ALTERNATIVES

As stated above, the primary goal of this Stage 2 AP is to evaluate and select an appropriate method to reduce or minimize the migration of inorganic COCs from the shallow soils within the former RO reject discharge fields to the shallow groundwater. The removal or minimization of migration of inorganic COCs from the shallow soils should enhance the natural attenuation of COCs in groundwater. Shallow soil COCs include Iron, Manganese, Fluoride, and Sulfate.

3.1 POTENTIAL REMEDIATION ALTERNATIVES

There are limited remediation alternatives that will minimize leaching of inorganic chemicals through the unsaturated zone. These alternatives include soil stabilization or certain phytotechnology mechanisms, that either reduce infiltration by evapotranspiration, extract the chemicals by phytoextraction, or sequester the chemical in the roots of the plant. Other alternatives that would meet the remediation goal include installing an impervious cover and solidification of the soil; however, because of the size of the former RO reject discharge fields and feasibility of implementation, neither of these alternatives are currently being considered.

3.1.1 SOIL STABILIZATION

The Stage 1 AP concluded that fluoride was the COC of most concern based on the concentrations reported in the soil samples analyzed using the synthetic precipitation leaching procedure (SPLP) and groundwater concentrations. Thus, soil stabilization of fluoride was also considered as a remediation alternative. Fluoride in soil is primarily associated with the soil colloid or clay fraction and its mobility in soil is highly dependent on the soil's sorption capacity, which varies with pH, the types of sorbents present, and soil salinity. The clay and organic carbon content as well as the pH of soil are primarily responsible for the retention of fluoride in soils. In soils, fluoride is predominantly combined with aluminum or calcium. Fluoride forms its most stable bonds with iron, aluminum, and calcium. Labile fluoride is held by soil components that contain these elements, including clay minerals, calcium and magnesium compounds, and iron and aluminum compounds (Omueti and Jones 1977). Macintire (Macintire 1950) also reported that some soils, especially those with relatively high calcium content, were very effective in fixing fluoride. The soil within the fields is alkaline in nature with a high calcium content and elevated iron concentrations. Thus, soil stabilization does not appear to be a feasible remediation alternative.

3.1.2 PHYTOTECHNOLOGY MECHANISMS

The natural physiological processes of plants are the basis for the various phytotechnology mechanisms that can serve as remediation alternatives for the former RO reject discharge fields. Certain species of vegetation have the capability to take up and transpire, and thereby remove, significant volumes of surface water, soil pore water and/or groundwater. This mechanism is termed phytohydraulics. The vertical migration of water from the surface downward can be limited by the water interception capacity of the aboveground canopy and subsequent evapotranspiration through the root system. As this water is consumed by the plants, dissolved contaminants can be sequestered in the roots (phytosequestration) or taken up into the plant through the roots and translocate the contaminants to the aboveground shoots or leaves of the plant (phytoextraction). For contaminants to be extracted by plants, the constituent must be dissolved in the soil water and come into contact with the plant roots through the transpiration stream. Thus, phytoremediation has been selected as the remediation alternative for soil.

As the phytoremediation proceeds, the concentrations of COCs in the soil and soil pore water will decrease and the potential for leaching of COCs to groundwater will also decrease. Natural attenuation of COCs in groundwater should then occur and the concentrations of COCs in the groundwater should return to similar levels observed in upgradient (background) groundwater. Thus, monitored natural attenuation (MNA) has been selected as the remediation alternative for groundwater.

3.2 PHYTOREMEDIATION PILOT STUDY DESIGN

Although a preliminary phytoremediation study was performed with the results included in the Stage 1 AP report, that study was limited and did not provide enough data to design a full phytoremediation plan. This section describes a stepwise approach to designing a phytoremediation pilot study including performing specific agronomic soil analysis to assist in species selection, as well as amendment and fertilizer needs, and provides further evaluation of potential species and provides details of additional pilot study activities that will be conducted prior to implementation of the full-scale remediation.

3.2.1 SOIL AND SITE SUITABILITY

The initial step in designing the phytoremediation pilot study will be to collect appropriate soil data to evaluate the plant growth conditions of the fields. There are limited data on the agronomic quality of the soil in the former RO reject discharge fields; therefore, additional soil information will be collected to help with species selection and evaluate the plant growth potential of the soil. Previous investigations of the RO fields have provided limited data on the soil profile from the surface through the capillary fringe. Soil samples are needed at specific depths (0–1, 1–2, and 2–4 feet) and will be used to assess the agronomic characteristics of the site soils. The results of these analyses will also assist in designing a fertility management program for the pilot study.

Samples will be collected from three locations in each of the two former RO reject discharge fields at the three specified depths. The three samples from a specific depth will be composited and a composite sample will be submitted for laboratory analysis. Thus, each field will have three soil samples (composite from each depth interval) that will be submitted to an agricultural laboratory for the following agronomic analysis:

- Soil Organic Matter – Method S-9.20
- Soil pH – Method S-2.20
- Cation Exchange Capacity – Method S-10.10
- Soil Nitrate-Nitrogen – Method S-3.10
- Extractable Soil Phosphorus and Soil Bases
 - Potassium, Calcium, Magnesium and Sodium -- Method S-5.11
 - Phosphorus – Method S-4.40
- Soil Micronutrient
 - Zinc, Manganese, Iron, Copper, and Boron -- Method S-6.12
- Soil Chloride – Method S-12.10
- Extractable Aluminum – Method S-15.10
- Extractable Soil Sulfate-Sulfur – Method S - 11.10
- Soil Ammonium Nitrogen – Method S-3.50
- Saturated Paste Extraction
 - Saturation Percentage – Method S-1.00
 - Saturation Paste Chloride Method S-1.40
 - Saturation Paste Boron – Method S-1.50
 - Saturation Paste Calcium, Magnesium, Sodium and SAR– Method S-1.60
 - Saturation Paste Soluble Salts – Method S-1.20

The six soil samples will be analyzed for the above constituents using methods approved and monitored by **North American Proficiency Testing Program** for agricultural analysis of soils.

The analytical results will be discussed with the agronomic experts familiar with soils in Eddy County to assist with development of the fertility management plan.

3.2.2 POTENTIAL SPECIES

The second step in the design process is to identify potential species that are suitable based on soil characteristics and meet the criteria for phytoremediation at the site.

The first criteria for potential species is tolerance to the soil COCs. As stated in the Stage 1 AP, Fluoride is the primary COC in soil; however fluoride is not an essential nutrient for plant growth and in certain cases can be toxic to plants by potentially impacting seed germination and overall plant growth. Due to the potential toxicity, a variety of species will be evaluated.

The second criteria for species selection is the potential water consumption. The historic average annual rainfall in Artesia is about 11.3 inches and the average annual evapotranspiration is reported at 75 inches with most of the evapotranspiration occurring during the April to November frost free season. Candidate species should have natural water use that exceeds the annual rainfall of the area.

The third criteria for potential species are ones that are native to the area or of a type that will effectively grow in the specific environment, which is semi-arid.

Several species have been identified as potential candidates for including in the phytoremediation pilot study. Selection criteria are based on the plant's ability to:

- reduce infiltration into the soil profile by interception,
- have water use that exceeds evapotranspiration from rainfall,
- sequester soil COCs or transport chemicals dissolved in the pore water into the aboveground biomass of the plant through transpiration, and
- are native or will effectively grow in the Artesia, New Mexico area.

Potential candidate species include:

- Sudan Grass
- Western Wheat Grass
- Indian Grass
- Tall Wheat Grass

Both Sudan Grass and Indian Grass are expected to develop a root structure that will extend between 9 to 12 feet deep. While the roots of the Western Wheatgrass and Tall Wheatgrass are typically shallower, these two species are known to uptake more water than the typical rainfall and are expected to grow well in the area. Additional species may be evaluated based on the results of the soil chemical analysis performed as the initial step in the design process and consultation with local agronomic experts.

As the total root depth is established, the candidate species should provide phytoremediation of soils from the surface to a depth of approximately 9 to 12 feet bgs. Considering the bulk of the COC loading is in the shallowest portion of the vadose zone (**Appendix A**), the selected species will be effective in sequestering the COCs from the soil and pore water in the upper 12 feet and allow for natural attenuation of the COCs in the remaining portion (about 4 additional feet or to 16 feet bgs) of the vadose zone soils.

3.2.3 PILOT STUDY PLOT DESIGN

Assuming the candidate species are suitable based on soil characteristics, the pilot study design will be finalized including a fertility management plan. The fertility management plan will consist of applying fertilizers at agronomic rates for the selected species. Agronomic rates are based on the actual reported plant uptake of specific plant nutrients including nitrogen, phosphorus and potassium and will also consider timing of applications to minimize potential for leaching of applied nutrients. The pilot study will consist of testing two of the candidate species in the North RO reject discharge fields and the remaining two in the South RO reject discharge field. If other species are identified during the evaluation process, they will be added in proportion to each of the fields. The North RO reject discharge field is approximately 25.3 acres and the South RO reject discharge field is approximately 28.9 acres in size.

3.2.3.1 IRRIGATION WATER SUPPLY

The selected species will require addition of water during the growing season to maintain a vegetative cover that will minimize infiltration and maximize sequestration of soil COCs. As an example, irrigated sorghum and sudan grass grown as part of a performance test at the New Mexico Agricultural Service Center in Artesia required about an additional 28 inches of irrigation water during the growing season to produce a 2-cutting crop. Native species may require less water. Irrigation requirements for these species will be monitored by the soil moisture probes installed in the field (see Section 3.2.3.2).

The refinery obtains water from a mixture of water supply wells and the City of Artesia public water. Both the city water and the water supply wells will be evaluated as potential irrigation water sources, as needed. A sample of the potential irrigation water source(s) will be analyzed for the following:

- pH (field equipment)
- Electrical Conductivity (field equipment)
- TDS by Method 2540
- Alkalinity by Method 2320
- Carbonate
- Bicarbonate
- Anions by Method 300 or 9056
- Chloride
- Fluoride
- Sulfate-Sulfur
- Nitrate (as Nitrogen) by Method 300 or 9056
- Dissolved Metals by Method 6010 or 6020:
 - Boron
 - Calcium
 - Copper
 - Iron
 - Magnesium
 - Manganese
 - Potassium
 - Sodium
 - Zinc

The results of the water sampling will be used to determine the best water source for irrigation during the pilot study. A different source may be used for the two different fields, depending on availability and method selected to apply irrigation water.

3.2.3.2 FINAL DESIGN

The pilot study design will be finalized based on the results of soil and water analysis described above. The agronomic data will provide information on nutrient needs and soil and water constraints. The final design will include general plans and specifications for site preparation including removal of existing vegetation (if needed), planting guidelines, and management protocols that need to be implemented once the pilot study plots are established. The final design will also include details on the irrigation system that will be used during the pilot study.

Existing soil moisture probes installed during the Stage 1 AP will be evaluated to determine if they are still functioning. These probes will be used and if needed, additional soil moisture probes will be installed, to monitor soil moisture and electrical conductivity (EC) at multiple depths in the soil profile. The number of probes and locations for the probes will be determined based on the evaluation of the existing probes. The data will be used to evaluate the need for irrigation and to monitor soil moisture changes with depth over time. The Stage 1 AP soil moisture probes were placed at depths of 2, 5, and 10 feet bgs at each location. If additional probes (or replacement probes) need to be installed, a hand auger or a direct-push rig will be used to advance a boring to a depth of 10 feet bgs at each location, then the probes will be placed at the desired depth according to

the manufacturer's installation instructions. Each probe will be attached to a solar-powered data logger, and data will be automatically downloaded at regular intervals.

Soil moisture probes will remain in place throughout the pilot study as well as during implementation of the full-scale phytoremediation, and data will continue to be collected to evaluate the vadose zone moisture.

3.3 PHYTOREMEDIATION PILOT STUDY IMPLEMENTATION

A local agricultural contractor will be retained to install and manage the plots. Plans and specifications developed as part of the final design will provide details as to the plant material, planting techniques including compost and fertilizer requirements, irrigation design, and follow up maintenance. It should be noted that after the system is implemented, ongoing operation, maintenance, and monitoring will be conducted to ensure the vegetation develops vigorous and deep root systems.

The following activities will be conducted throughout the pilot study:

- Weekly monitoring during the growing season. Monitoring inspections will include evaluation of plant health and growth characteristics, pests, and weed competition. These activities will be performed by field technicians trained to perform the specific monitoring tasks, with periodic oversight by a certified crop advisor or agronomist to address growth issues or pest and disease issues.
- Pest monitoring and weed control: Pests can decimate a crop, and weeds provide unnecessary competition for water and nutrients that are important for plant growth. In the event that insecticides or herbicides are required to control pests or weeds, HFSNR will select the most environmentally sound alternative for the specific need and request concurrence from the OCD prior to use. HFSNR will report the agent and quantity used to OCD in the quarterly status reports.
- Periodic fertilization: Fertilizer selection, as needed, will be based on the results of the evaluation of current soil nutrient conditions conducted prior to the initial planting. The residual nutrients in soil and in the irrigation water will be accounted for when assessing fertility needs. Fertilizers may be applied either in liquid or granular form, depending on the fertilization requirements. Liquid fertilizer would be applied through a spraying system while granular fertilizer would be broadcast on the ground surface. Fertilizer will be applied at or slightly below agronomic rates to avoid the potential for additional leaching of COCs. HFSNR will seek concurrence from the OCD, prior to application, for fertilizer to be applied during the initial planting and during subsequent growing seasons. Subsequent fertilizer applications will be based on additional agronomic sampling results. HFSNR will report the fertilizer and quantity used to OCD in the quarterly status reports.
- Irrigation will be required to establish the vegetation and during growing season when soil moisture content drops below the ideal range for the species. The level of irrigation oversight will be dependent on the selected water source and the type of irrigation system selected.
- Evaluation of plant growth will be conducted to determine if or when the plants need to be harvested or cut back. Vegetation that is harvested or cut will be removed from the fields and contained by bailing, bagging, or placing into a rolloff bin. Representative samples will be collected for analysis of soil and groundwater COCs and any additional parameters required for waste characterization, as per the potential disposal facilities. The vegetation will be characterized as either hazardous or non-hazardous for offsite disposal at an approved facility and will not be used as food for humans or livestock. The actual disposal facility to be used for each disposal event will be determined by the waste characterization, facility capacity, and availability to receive wastes. Non-hazardous waste will likely be disposed at the Gandy Marley Inc. facility near Roswell, NM or the Eddy County Sandpoint Landfill in Carlsbad, NM. Hazardous waste will likely be disposed at the US Ecology Inc. facility in Robstown, TX or the Veolia North America facility near Arkadelphia, AR. Records of the source and volume of harvested vegetation, method of containment, analytical results, waste characterization determination, and copies of bills of lading or shipping manifests will be maintained at the Refinery and copies will be included in the final pilot study report and any future phytoremediation reports.

4 SCHEDULE AND REPORTING

4.1 SCHEDULE

The following is a tentative schedule for the phytoremediation pilot study, assuming that approval of this Stage 2 AP is received no later than May 1, 2024:

- May 1, 2024: OCD approval of Stage 2 AP received assumed
- May 1 to June 15, 2024: collect soil and water samples for laboratory analyses; install monitoring wells and moisture probes
- May 1 to July 15, 2024: finalize pilot study design based on laboratory analytical results and prepare detailed implementation specifications to include irrigation system selection and maintenance guidelines
- June 15 to August 31, 2024: select implementation contractor, prepare fields including installation of moisture probes (as needed), confirm seed sources
- September 15 to October 15, 2024: plant pilot study species (excluding Sudan grass since it will not survive winter)
- September 15, 2024 to September 1, 2025: operate and maintain pilot study, plant Sudan grass in spring 2025
- September 1 to September 30, 2025: harvest / cut plants from both fields, plant winter crop on field where Sudan grass was tested
- October 1, 2025 to March 1, 2026: finalize full scale phytoremediation design, submit report to OCD with recommendations for implementation

Adjustments to the schedule may be required and any changes will be communicated to OCD.

4.2 REPORTING

Status reports will be prepared for submittal to OCD throughout the phytoremediation pilot study. The reports will include:

- Quarterly status reports, beginning in July 2023, to describe the activities completed during the previous three months.
- Final pilot study design, to be submitted prior to implementation of the pilot study.
- Final report of pilot study, to be submitted within 90 days of the completion of the pilot study. The final report will include recommendations for the full-scale phytoremediation system.

5 PUBLIC NOTIFICATION

A draft public notification is provided in **Appendix D**. The draft public notification includes the information required by NMAC 20.6.2.4108.B and NMAC 20.6.2.4108.C. HFSNR will issue the public notification upon approval by OCD.

6 FINANCIAL ASSURANCE PLAN FOR CLOSURE/POST-CLOSURE CARE

The Stage 2 AP activities outlined above and the associated financial assurance cost estimates meet the requirements of NMAC 20.2.4104.C. **Appendix E-1** provides a financial assurance summary cost estimate for the activities described in this Stage 2 AP.

Cost estimates for the tasks to be performed during 2023, which include installation of monitoring wells and moisture probes, as well as the phytoremediation pilot study, are detailed in Appendix E-2 and E-4. The cost estimate for groundwater monitoring assumes the post-closure groundwater monitoring program will continue for 30 years and is detailed in Appendix E-3. A detailed cost estimate for years 2 and 3 of the phytoremediation implementation program is included as Appendix E-5.

HFSNR will provide the financial assurance for closure and post-closure activities within 30 days of OCD approval of this Stage 2 AP. The Stage 2 AP and financial assurance estimates are subject to change pending the results of the phytoremediation pilot study and groundwater monitoring results.

REFERENCES

- Macintire 1950. WH Mcintire, in “Air versus soil as channels for fluoric contamination of vegetation in two Tennessee locates”. Edited by McCabe, LC. pp. 53-58 of Proceedings of U.S. technical conference on air pollution, Interdepartmental committee on air pollution – Washington D.C. 1950.
- NMED 2001. Use of Low-Flow and Other Non-Traditional Sampling Techniques for RCRA Compliant Groundwater Monitoring, Position Paper. October 30, 2001.
- OCD 2017. Discharge Permit GW-028. May 25, 2017.
- OCD 2018. Discharge Permit GW-028 Modification, December 14, 2018.
- OCD 2022. Discharge Permit GW-028. August 16, 2022.
- Omueti and Jones 1977. Omueti, J. A. I. and Jones, R. L. Fluoride adsorption by Illinois soils. Journal of Soil Sciences. 28:564-572. 1977.
- TRC 2021. 2020 Annual Groundwater Report. February 26, 2021.
- TRC 2022. 2021 Annual Groundwater Report. February 28, 2022.
- Wood 2019a. Stage 1 Abatement Plan for the Reverse Osmosis Reject Discharge Fields Discharge Permit GW-028. March 21, 2019.
- Wood 2019b. Amendment of the March 2019 Stage 1 Abatement Plan for the Reverse Osmosis Reject Discharge Fields. May 24, 2019.
- Wood 2020. Reverse Osmosis Reject Discharge Fields Stage 1 Abatement – Final Report. November 19, 2020.

TABLES



**Table 1 - Summary of Groundwater Analytical Results Screened Using WQCC Standards
Reverse Osmosis Reject Discharge Fields Stage 2 Abatement Plan Work Plan**

Analyte Group:	Total Metals							Dissolved Metals							
	Arsenic	Boron	Cobalt	Iron	Lead	Manganese	Uranium	Arsenic	Boron	Cobalt	Iron	Lead	Manganese	Uranium	
	mg/L	mg/L	mg/L	mg/L	mg/L	mg/L	mg/L	mg/L	mg/L	mg/L	mg/L	mg/L	mg/L	mg/L	
	CGWSL:	0.01	0.75	0.05	1.0	0.015	0.2	0.03	0.01	0.75	0.05	1.0	0.015	0.2	0.03
	CGWSL Source:	WQCC HH	WQCC Irr	WQCC Irr	WQCC Dom	WQCC HH	WQCC Dom	WQCC HH	WQCC HH	WQCC Irr	WQCC Irr	WQCC Dom	WQCC HH	WQCC Dom	WQCC HH

Location	Well	Event	Date	Type	Total Metals							Dissolved Metals									
North RO Field																					
Upgradient	MW-55	Stage 1 AP Quarter 1	Jul-19	N																	
		Stage 1 AP Quarter 2	Oct-19	N	0.00615	1.07	<0.000260	0.0207 J	<0.0020	BJU	0.132	0.0513	0.00595	1.00	<0.000260	<0.0141	<0.0020	BJU	0.126	0.0504	
			Oct-19	FD	0.00618	1.03	<0.000260	0.0288 J	<0.000240		0.133	0.0511	0.00605	1.01	<0.000260	<0.0141	<0.0020	BJU	0.128	0.0528	
		Stage 1 AP Quarter 3	Jan-20	N																	
			Jan-20	FD																	
		Stage 1 AP Quarter 4	Jun-20	N	0.00608	0.992	<0.000477	<0.0458	<0.00249		0.142	0.0548	0.00663	0.951	<0.000477	<0.0458	<0.00249		0.148	0.0549	
		2nd Semiannual 2020	Oct-20	N	0.00684	0.695	<0.000477	0.0508 J	<0.00249		0.168	0.0364									
		1st Semiannual 2021	Apr-21	N	0.00683	0.631	0.000304 J	<0.0281	0.00103 J		0.185	0.0314	0.00628	0.644	0.000223 J	<0.0281	0.00144 J		0.171	0.0292	
		2nd Semiannual 2021	Sep-21	N	0.00611	0.608	0.000311 J	<0.0281	<0.000849		0.202	0.0272									
		1st Semiannual 2022	Apr-22	N	0.00633	0.55	0.000316 J	<0.0281	<0.000849		0.211	0.0201	0.00679	0.555	0.000849 J	<0.0281	<0.000849		0.206	0.0188	
	2nd Semiannual 2022	Oct-22	N	0.0055	0.449	0.00341	<0.0281	<0.000849		0.35	0.0215										
	MW-140	Stage 1 AP Quarter 1	Jul-19	N																	
		Stage 1 AP Quarter 2	Oct-19	N	0.00241	0.412	<0.000260	0.224	<0.0020	BJU	0.102	0.0318	0.00247	0.395	<0.000260	<0.0141	<0.0020	BJU	0.0975	0.0325	
		Stage 1 AP Quarter 3	Jan-20	N																	
		Stage 1 AP Quarter 4	Jun-20	N	0.00262	0.468	<0.000477	<0.0458	<0.00249		0.0636	0.0359	0.00265	0.445	<0.000477	<0.0458	<0.00249		0.00615	0.0348	
			Jun-20	FD	0.00252	0.460	<0.000477	<0.0458	<0.00249		0.0678	0.0323	0.00273	0.442	<0.000477	<0.0458	<0.00249		0.0564	0.0336	
		2nd Semiannual 2020	Oct-20	-																	
		1st Semiannual 2021	Apr-21	-																	
		2nd Semiannual 2021	Sep-21	-																	
		1st Semiannual 2022	Apr-22	-																	
		2nd Semiannual 2022	Oct-22	-																	
	MW-141	Stage 1 AP Quarter 1	Jul-19	N																	
			Jul-19	FD																	
		Stage 1 AP Quarter 2	Oct-19	N	0.00389	0.215	0.000333 J	0.132	<0.0020	BJU	0.00939	0.0280	0.00360	0.218	0.000308 J	0.0159 J	<0.000240		0.00925	0.0288	
		Stage 1 AP Quarter 3	Jan-20	N																	
		Stage 1 AP Quarter 4	Jun-20	N	0.00310	BJ	0.196	J	<0.000477	<0.0458	<0.00249	0.00205 J	0.0244	0.00297	0.200 J	<0.000477	<0.0458	<0.00249	0.00132 J	0.0259	
		2nd Semiannual 2020	Oct-20	-																	
		1st Semiannual 2021	Apr-21	-																	
2nd Semiannual 2021		Sep-21	-																		
1st Semiannual 2022		Apr-22	-																		
2nd Semiannual 2022		Oct-22	-																		
In Field	MW-117	Stage 1 AP Quarter 1	Jul-19	N																	
		Stage 1 AP Quarter 2	Oct-19	N	0.0025	0.145	J	<0.000260	0.0611 J	<0.000240	<0.0050	BJU	0.0176	0.00243	0.147 J	<0.000260	0.0195 J	<0.000240	<0.0050	BJU	0.0172
		Stage 1 AP Quarter 3	Jan-20	N																	
		Stage 1 AP Quarter 4	Jun-20	N	0.00248	0.143	J	<0.000477	0.261	<0.00249	0.00392 J	0.0152 J	0.00246	0.131 J	<0.000477	<0.0458	<0.00249	0.00158 J	0.0160 J		
		2nd Semiannual 2020	Oct-20	N	0.00255				0.132	<0.00249	0.00353 J										
		1st Semiannual 2021	Apr-21	N	0.0026				0.112	0.00109 J	0.00472 J		0.00263			<0.0281	<0.000849	0.00408 J			
		2nd Semiannual 2021	Sep-21	N	0.00286				0.144	0.00213	0.00367 J										
		1st Semiannual 2022	Apr-22	N	0.00285				<0.0281	<0.000849	0.00412 J		0.00353			<0.0281	<0.000849	0.00305 J			
		2nd Semiannual 2022	Oct-22	N	0.00265				0.0455 J	<0.000849	0.00419 J										
		MW-118	Stage 1 AP Quarter 1	Jul-19	N																
	Stage 1 AP Quarter 2		Oct-19	N	0.00871	0.352	<0.000260	0.127	<0.000240	<0.0050	BJU	0.0371	0.00863	0.366	<0.000260	<0.0141	<0.0020	BJU	<0.0050	BJU	0.0370
	Stage 1 AP Quarter 3		Jan-20	N																	
	Stage 1 AP Quarter 4		Jun-20	N	0.00753	0.381	<0.000477	0.137	<0.00249	0.00167 J	0.0360	0.00787	0.399	<0.000477	<0.0458	<0.00249	<0.00132		0.0390		
	2nd Semiannual 2020		Oct-20	N	0.0077				0.249	<0.00249	0.00273 J										
	1st Semiannual 2021		Apr-21	N	0.00732				0.0458 J	<0.000849	<0.000704		0.00732			<0.0281	<0.000849	<0.000704			
	2nd Semiannual 2021		Sep-21	N	0.00641				0.0652 J	<0.000849	0.00119 J										
	1st Semiannual 2022		Apr-22	N	0.00634				0.117	<0.000849	0.00124 J		0.00614			0.0339 J	<0.000849	<0.000704			
	2nd Semiannual 2022	Oct-22	N	0.00621				0.0611 J	<0.000849	0.00142 J											

**Table 1 - Summary of Groundwater Analytical Results Screened Using WQCC Standards
Reverse Osmosis Reject Discharge Fields Stage 2 Abatement Plan Work Plan**

Analyte Group:	Total Metals							Dissolved Metals							
	Arsenic	Boron	Cobalt	Iron	Lead	Manganese	Uranium	Arsenic	Boron	Cobalt	Iron	Lead	Manganese	Uranium	
	Units:	mg/L	mg/L	mg/L	mg/L	mg/L	mg/L	mg/L	mg/L	mg/L	mg/L	mg/L	mg/L	mg/L	
	CGWSL:	0.01	0.75	0.05	1.0	0.015	0.2	0.03	0.01	0.75	0.05	1.0	0.015	0.2	0.03
	CGWSL Source:	WQCC HH	WQCC Irr	WQCC Irr	WQCC Dom	WQCC HH	WQCC Dom	WQCC HH	WQCC HH	WQCC Irr	WQCC Irr	WQCC Dom	WQCC HH	WQCC Dom	WQCC HH

Location	Well	Event	Date	Type	Total Metals							Dissolved Metals								
	MW-119	Stage 1 AP Quarter 1	Jul-19	N																
		Stage 1 AP Quarter 2	Oct-19	N	0.00430	0.334	0.000429 J	0.805	<0.0020	BJU	0.0188	0.0322	0.00388	0.338	<0.000260	0.0215 J	<0.0020	BJU	0.00524	0.0325
		Stage 1 AP Quarter 3	Jan-20	N																
		Stage 1 AP Quarter 4	Jun-20	N	0.00376	0.482	<0.000477	<0.0458	<0.00249		0.00633	0.0451	0.00384	0.457	<0.000477	<0.0458	<0.00249		0.00643	0.0467
		2nd Semiannual 2020	Oct-20	N	0.00451			0.0836 J	<0.00249		0.0114 B									
		1st Semiannual 2021	Apr-21	N	0.00449			0.276	<0.000849		0.0119		0.00435		<0.0281	<0.000849		0.00426 J		
		2nd Semiannual 2021	Sep-21	N	0.00343			0.0477 J	<0.000849		0.00435 J									
		1st Semiannual 2022	Apr-22	N	0.00442			0.206	<0.000849		0.0144		0.00393		<0.0281	<0.000849		0.00231 J		
2nd Semiannual 2022	Oct-22	N	0.00414			0.0524 J	<0.000849		0.00497 J											
Downgradient	MW-142	Stage 1 AP Quarter 1	Jul-19	N																
		Stage 1 AP Quarter 2	Oct-19	N	0.00364	0.381	0.000744 J	1.55	<0.0020	BJU	0.0257	0.0371	0.00317	0.380	0.000525 J	0.0160 J	<0.000240		0.0177	0.0369
		Stage 1 AP Quarter 3	Jan-20	N																
		Stage 1 AP Quarter 4	Jun-20	N	0.00327	0.430	<0.000477	<0.0458	<0.00249		0.0140	0.0410	0.00336	0.402	<0.000477	<0.0458	<0.00249		0.0130	0.0401
		2nd Semiannual 2020	Oct-20	-																
		1st Semiannual 2021	Apr-21	-																
		2nd Semiannual 2021	Sep-21	-																
		1st Semiannual 2022	Apr-22	-																
2nd Semiannual 2022	Oct-22	-																		
	MW-143	Stage 1 AP Quarter 1	Jul-19	N																
		Stage 1 AP Quarter 2	Oct-19	N	0.00338	0.870	0.00239	0.419	<0.0020	BJU	0.109	0.0491	0.00336	0.848	0.00248	0.0249 J	<0.0020	BJU	0.107	0.0484
		Stage 1 AP Quarter 3	Jan-20	N																
		Stage 1 AP Quarter 4	Jun-20	N	0.00339	0.865	0.000864 J	<0.0458	<0.00249		0.0511	0.0468	0.00318	0.839	0.000816 J	<0.0458	<0.00249		0.0432	0.0473
		2nd Semiannual 2020	Oct-20	-																
		1st Semiannual 2021	Apr-21	-																
		2nd Semiannual 2021	Sep-21	-																
		1st Semiannual 2022	Apr-22	-																
2nd Semiannual 2022	Oct-22	-																		
South RO Field																				
Upgradient	MW-29	Stage 1 AP Quarter 1	Jul-19	N																
		Stage 1 AP Quarter 2	Oct-19	N	0.0157	1.33	<0.000260	4.37	0.00892		0.579 V	0.0190	0.0143	1.26	<0.000260	4.05	<0.0020	BJU	0.574 V	0.0189
		Stage 1 AP Quarter 3	Jan-20	N																
		Stage 1 AP Quarter 4	Jun-20	N	0.00746	1.10	<0.000477	<0.0458	<0.00249		0.234	0.00789 J	0.00674	1.10	<0.000477	<0.0458	<0.00249		0.229	0.00811 J
			Jun-20	FD	0.00772	1.12	<0.000477	0.0704 J	<0.00249		0.223	<0.00754	0.00735	1.06	<0.000477	<0.0458	<0.00249		0.214	0.00779 J
		2nd Semiannual 2020	Oct-20	N	0.017			0.294	<0.00249		0.233 V									
		1st Semiannual 2021	Apr-21	N	0.0433			1.62	0.00137 J		0.414		0.0165		0.217	<0.000849		0.456		
		2nd Semiannual 2021	Sep-21	N	0.104			25.5	0.00119 J		1.4									
	1st Semiannual 2022	Apr-22	N	0.011			0.801	<0.000849		0.385		0.00923		0.373	<0.000849		0.381			
	2nd Semiannual 2022	Oct-22	N	0.103			12.9	0.00265		1.16										
	MW-40	Stage 1 AP Quarter 1	Jul-19	N																
		Stage 1 AP Quarter 2	Oct-19	N	0.00106 J	0.311	<0.000260	0.270 J	<0.0020	BJU	0.0233	0.000622 J	0.000851 J	0.292	<0.000260	0.0179 J	<0.0020	BJU	0.0238	0.000544 J
			Oct-19	FD	0.000878 J	0.300	<0.000260	0.135 J	<0.0020	BJU	0.0239	0.000602 J	0.000829 J	0.305	<0.000260	0.0236 J	<0.0020	BJU	0.0243	0.000538 J
		Stage 1 AP Quarter 3	Jan-20	N																
Jan-20			FD																	
Stage 1 AP Quarter 4		Jun-20	N	<0.000735	0.315	<0.000477	0.145	<0.00249		0.0255	<0.00754	<0.000735	0.308	<0.000477	<0.0458	<0.00249		0.0266	<0.00754	
2nd Semiannual 2020	Oct-20	-																		
1st Semiannual 2021	Apr-21	-																		
2nd Semiannual 2021	Sep-21	-																		
1st Semiannual 2022	Apr-22	-																		
2nd Semiannual 2022	Oct-22	-																		

**Table 1 - Summary of Groundwater Analytical Results Screened Using WQCC Standards
Reverse Osmosis Reject Discharge Fields Stage 2 Abatement Plan Work Plan**

Analyte Group:	Total Metals							Dissolved Metals						
	Arsenic	Boron	Cobalt	Iron	Lead	Manganese	Uranium	Arsenic	Boron	Cobalt	Iron	Lead	Manganese	Uranium
Analyte:	mg/L	mg/L	mg/L	mg/L	mg/L	mg/L	mg/L	mg/L	mg/L	mg/L	mg/L	mg/L	mg/L	mg/L
Units:	mg/L	mg/L	mg/L	mg/L	mg/L	mg/L	mg/L	mg/L	mg/L	mg/L	mg/L	mg/L	mg/L	mg/L
CGWSL:	0.01	0.75	0.05	1.0	0.015	0.2	0.03	0.01	0.75	0.05	1.0	0.015	0.2	0.03
CGWSL Source:	WQCC HH	WQCC Irr	WQCC Irr	WQCC Dom	WQCC HH	WQCC Dom	WQCC HH	WQCC HH	WQCC Irr	WQCC Irr	WQCC Dom	WQCC HH	WQCC Dom	WQCC HH

Location	Well	Event	Date	Type	Arsenic	Boron	Cobalt	Iron	Lead	Manganese	Uranium	Arsenic	Boron	Cobalt	Iron	Lead	Manganese	Uranium						
	MW-56	Stage 1 AP Quarter 1	Jul-19	N																				
		Stage 1 AP Quarter 2	Oct-19	N	0.00515	0.284	0.00698	<0.0141	<0.0020	BJU	0.306	0.0178	0.00524	0.269	0.00699	<0.0141	<0.0020	BJU	0.304	0.0173				
		Stage 1 AP Quarter 3	Jan-20	N																				
		Stage 1 AP Quarter 4	Jun-20	N	0.00552	0.253	0.00786	<0.0458	<0.00249		0.302	0.0172	J	0.00521	0.259	0.00813	<0.0458	<0.00249		0.295	0.0175	J		
		2nd Semiannual 2020	Jun-20	N	0.00529			<0.0489	<0.00249		0.302			0.00665			<0.0489	<0.00249		0.342				
		1st Semiannual 2021	Apr-21	N	0.00529			<0.0281	0.00105	J	0.287			0.00538			<0.0281	0.00128	J	0.274				
		2nd Semiannual 2021	Sep-21	-																				
		1st Semiannual 2022	Apr-22	N	0.00501			0.0459	J	<0.000849		0.219		0.00541			<0.0281	<0.000849		0.207				
		2nd Semiannual 2022	Oct-22	-																				
In Field	MW-114	Stage 1 AP Quarter 1	Jul-19	N																				
		Stage 1 AP Quarter 2	Oct-19	N	0.00295	0.118	J	0.00643	<0.0141	<0.000240		1.03	0.0107	0.00286	0.122	J	0.00604	<0.0141	<0.0020	BJU	0.972	0.0108		
		Stage 1 AP Quarter 3	Jan-20	N																				
		Stage 1 AP Quarter 4	Jun-20	N	0.00353	0.121	J	0.00618	<0.0458	<0.00249		0.959	0.00950	J	0.00364	0.109	J	0.00583	<0.0458	<0.00249		0.927	0.00917	J
		2nd Semiannual 2020	Oct-20	N	0.004				<0.0489	<0.00249		0.925												
		1st Semiannual 2021	Apr-21	N	0.00459				0.34	<0.000849		0.834		0.00460			<0.0281	<0.000849		0.889				
		2nd Semiannual 2021	Sep-21	N	0.00483				<0.0281	<0.000849		0.842												
		1st Semiannual 2022	Apr-22	N	0.00377				<0.0281	<0.000849		0.695		0.00388			<0.0281	<0.000849		0.746				
	2nd Semiannual 2022	Oct-22	N	0.00529				<0.0281	<0.000849		0.89													
	MW-115	Stage 1 AP Quarter 1	Jul-19	N																				
		Stage 1 AP Quarter 2	Oct-19	N	0.00443	0.780	0.00109	J	0.286	<0.0020	BJU	0.155	0.0793	0.00405	0.767	0.000362	J	<0.0141	<0.0020	BJU	0.120	0.0825		
		Stage 1 AP Quarter 3	Jan-20	N																				
		Stage 1 AP Quarter 4	Jun-20	N	0.00400	0.520	<0.000477		<0.0458	<0.00249		0.125	0.0953	0.00430	0.564	<0.000477		<0.0458	<0.00249		0.109	0.0947		
		2nd Semiannual 2020	Oct-20	N	0.00435				<0.0489	<0.00249		0.0983												
1st Semiannual 2021		Apr-21	N	0.00467				<0.140	<0.000849		0.0602		0.00407			<0.0281	<0.000849		0.0444					
2nd Semiannual 2021	Sep-21	N	0.00433				<0.0281	<0.000849		0.0334														
1st Semiannual 2022	Apr-22	N	0.00444				<0.0281	<0.000849		0.0593		0.00458			<0.0281	<0.000849		0.0405						
2nd Semiannual 2022	Oct-22	N	0.00533				<0.0281	<0.000849		0.0465														
MW-116	Stage 1 AP Quarter 1	Jul-19	N																					
	Stage 1 AP Quarter 2	Oct-19	N	0.00314	0.215	0.00231	0.0285	J	<0.000240	0.00834	0.0268	0.00323	0.205	0.00233	<0.0141	<0.000240		0.00748	0.0271					
	Stage 1 AP Quarter 3	Jan-20	N																					
	Stage 1 AP Quarter 4	Jun-20	N	0.00292	0.227	0.00240	0.0746	J	<0.00249	0.0128	0.0273	0.00290	0.220	0.00254	<0.0458	<0.00249		0.00781	0.0287					
	2nd Semiannual 2020	Oct-20	N	0.00300			0.0902	J	<0.00249	0.015	B													
	1st Semiannual 2021	Apr-21	N	0.00289			0.366	<0.000849		0.0199		0.00311			<0.0281	<0.000849		0.0105						
	2nd Semiannual 2021	Sep-21	N	0.00306			0.0549	J	<0.000849	0.0227														
	1st Semiannual 2022	Apr-22	N	0.00296			0.0323	J	<0.000849	0.0366		0.00283			<0.0281	<0.000849		0.0308						
2nd Semiannual 2022	Oct-22	N	0.00373			0.0502	J	<0.000849	0.0916															
Downgradient	MW-125	Stage 1 AP Quarter 1	Jul-19	N																				
		Stage 1 AP Quarter 2	Oct-19	N	0.00363	0.519	0.00633	0.0167	J	<0.000240	0.418	0.0383	0.00362	0.509	0.00526	<0.0141	<0.000240		0.399	0.0382				
		Stage 1 AP Quarter 3	Jan-20	N																				
		Stage 1 AP Quarter 4	Jun-20	N	0.00357	0.519	0.00760	<0.0458	<0.00249		0.413	0.0351	0.00342	0.498	0.00557	<0.0458	<0.00249		0.389	0.0365				
		2nd Semiannual 2020	Oct-20	N	0.00367			<0.0489	<0.00249		0.43													
		1st Semiannual 2021	Apr-21	N	0.00388			0.0682	J	<0.000849	0.444		0.0033			<0.0281	<0.000849		0.402					
		2nd Semiannual 2021	Sep-21	N	0.00331			<0.0281	<0.000849		0.413													
		1st Semiannual 2022	Apr-22	N	0.00343			<0.0281	<0.000849		0.387		0.00371			<0.0281	<0.000849		0.411					
2nd Semiannual 2022	Oct-22	N	0.00348			<0.0281	<0.000849		0.408															

**Table 1 - Summary of Groundwater Analytical Results Screened Using WQCC Standards
Reverse Osmosis Reject Discharge Fields Stage 2 Abatement Plan Work Plan**

Analyte Group:					Total Metals							Dissolved Metals							
Analyte:	Arsenic	Boron	Cobalt	Iron	Lead	Manganese	Uranium	Arsenic	Boron	Cobalt	Iron	Lead	Manganese	Uranium					
Units:	mg/L	mg/L	mg/L	mg/L	mg/L	mg/L	mg/L	mg/L	mg/L	mg/L	mg/L	mg/L	mg/L	mg/L					
CGWSL:	0.01	0.75	0.05	1.0	0.015	0.2	0.03	0.01	0.75	0.05	1.0	0.015	0.2	0.03					
CGWSL Source:	WQCC HH	WQCC Irr	WQCC Irr	WQCC Dom	WQCC HH	WQCC Dom	WQCC HH	WQCC HH	WQCC Irr	WQCC Irr	WQCC Dom	WQCC HH	WQCC Dom	WQCC HH					
Location	Well	Event	Date	Type															
MW-144	Stage 1 AP Quarter 1	Jul-19	N																
	Stage 1 AP Quarter 2	Oct-19	N	0.00338	0.216	0.000788 J	0.468	<0.0020 BJU	0.0365	0.0180	0.00320	0.211	0.000698 J	<0.0141	<0.0020 BJU	0.0272	0.0185		
	Stage 1 AP Quarter 3	Jan-20	N																
	Stage 1 AP Quarter 4	Jun-20	N	0.00361	0.237	0.000816 J	<0.0458	<0.00249	0.0216	0.0168 J	0.00375	0.224	0.000874 J	<0.0458	<0.00249	0.0170	0.0187 J		
	2nd Semiannual 2020	Oct-20	-																
	1st Semiannual 2021	Apr-21	-																
	2nd Semiannual 2021	Sep-21	-																
	1st Semiannual 2022	Apr-22	-																
	2nd Semiannual 2022	Oct-22	-																
	RW-18A	Stage 1 AP Quarter 1	Jul-19	N															
		Stage 1 AP Quarter 2	Oct-19	N	0.00281	0.675	<0.000260	0.556	<0.0020 BJU	0.00933	0.0583	0.00271	0.648	<0.000260	0.0519 J	<0.0020 BJU	0.00668	0.0566	
		Stage 1 AP Quarter 3	Jan-20	N															
		Stage 1 AP Quarter 4	Jun-20	N	0.00258	0.542	<0.000477	<0.00458	<0.00249	0.00320 J	0.0527	0.00280	0.506	<0.000477	<0.00458	<0.00249	0.00265 J	0.0565	
		2nd Semiannual 2020	Oct-20	-															
1st Semiannual 2021		Apr-21	-																
2nd Semiannual 2021		Sep-21	-																
1st Semiannual 2022		Apr-22	-																
2nd Semiannual 2022	Oct-22	-																	

**Table 1 - Summary of Groundwater Analytical Results Screened Using WQCC Standards
Reverse Osmosis Reject Discharge Fields Stage 2 Abatement Plan Work Plan**

Analyte Group:	General Chemistry											
Analyte:	Calcium	Chloride	Fluoride	Magnesium	Nitrate/Nitrite	Potassium	Sodium	Sulfate	Alkalinity - Bicarbonate	Alkalinity - Carbonate	Total Alkalinity	TDS
Units:	mg/L	mg/L	mg/L	mg/L	mg/L	mg/L	mg/L	mg/L	mg/L	mg/L	mg/L	mg/L
CGWSL:	--	250	1.6	--	1.0	--	--	600	--	--	--	1,000
CGWSL Source:	--	WQCC Dom	WQCC HH	--	WQCC HH ^a	--	--	WQCC Dom	--	--	--	WQCC Dom

Location	Well	Event	Date	Type	Calcium	Chloride	Fluoride	Magnesium	Nitrate/Nitrite	Potassium	Sodium	Sulfate	Alkalinity - Bicarbonate	Alkalinity - Carbonate	Total Alkalinity	TDS			
North RO Field																			
Upgradient	MW-55	Stage 1 AP Quarter 1	Jul-19	N	492	498	1.83	364	1.65	1.11	247	2,100	446	<2.71	446	4,680			
		Stage 1 AP Quarter 2	Oct-19	N	418	514	1.53	312	0.469	<1.00	BJU	237	1,570	489	<2.71	489	3,390		
			Oct-19	FD	413	523	1.67	305	0.453	<1.00	BJU	235	1,590	496	<2.71	496	3,350		
		Stage 1 AP Quarter 3	Jan-20	N	435	562	1.73	311	0.302	1.32		237	1,570	492	<2.71	492	2,820		
			Jan-20	FD	428	552	1.72	304	0.289	0.961	J	235	1,540	495	<2.71	495	3,480		
		Stage 1 AP Quarter 4	Jun-20	N	411	600	1.66	302	0.0746	J	0.804	J	243	1,340	553	<8.45	553	3,910	
		2nd Semiannual 2020	Oct-20	N	333	505	1.3		<0.0500		0.842	JB	228	949				3,010	
		1st Semiannual 2021	Apr-21	N	293	463	1.62		0.0762	J	0.683	J	244	781				2,130	
		2nd Semiannual 2021	Sep-21	N	282	448	1.58		<0.0500		0.644	J	199	770				2,520	
		1st Semiannual 2022	Apr-22	N	232	408	1.2		0.055	J	0.64	JB	228	685				2,120	
		2nd Semiannual 2022	Oct-22	N	291	348	1.44	J	<0.0500		0.679	J	191	1,020				2,230	
		MW-140	Stage 1 AP Quarter 1	Jul-19	N	659	293	1.82	241	15.5	39.6		168	2,430	295	<2.71	295	3,970	
	Stage 1 AP Quarter 2		Oct-19	N	639	310	1.44	240	9.29	45.2		170	2,220	311	<2.71	311	3,390		
	Stage 1 AP Quarter 3		Jan-20	N	637	310	1.79	235	10.3	58.3		172	2,190	304	<2.71	304	3,180		
	Stage 1 AP Quarter 4		Jun-20	N	624	305	1.66	231	9.65	50.3		180	2,020	331	<8.45	331	3,900		
			Jun-20	FD	628	305	1.74	227	10.3	49.5		177	2,150	330	<8.45	330	3,500	J	
	2nd Semiannual 2020		Oct-20	-															
	1st Semiannual 2021		Apr-21	-															
	2nd Semiannual 2021		Sep-21	-															
	1st Semiannual 2022		Apr-22	-															
	2nd Semiannual 2022		Oct-22	-															
	MW-141		Stage 1 AP Quarter 1	Jul-19	N	593	288	1.95	168	9.36	4.27		57.5	1,770	229	<2.71	229	2,660	
				Jul-19	FD	607	285	1.83	171	9.53	4.20		57.7	1,680	227	<2.71	227	2,900	
		Stage 1 AP Quarter 2	Oct-19	N	632	284	3.02	163	9.71	8.52		69.4	1,690	223	<2.71	223	2,880		
Stage 1 AP Quarter 3		Jan-20	N	597	275	2.35	157	8.54	5.37		58.5	1,570	224	<2.71	224	2,250			
Stage 1 AP Quarter 4		Jun-20	N	617	290	2.87	158	7.60	6.06		60.7	1,520	229	<8.45	229	3,260			
2nd Semiannual 2020		Oct-20	-																
1st Semiannual 2021		Apr-21	-																
2nd Semiannual 2021		Sep-21	-																
1st Semiannual 2022		Apr-22	-																
2nd Semiannual 2022		Oct-22	-																
In Field		MW-117	Stage 1 AP Quarter 1	Jul-19	N	597	284	3.40	268	0.191	6.54		107	2,230	344	<2.71	344	3,740	
			Stage 1 AP Quarter 2	Oct-19	N	583	305	3.02	264	0.395	6.81		108	2,260	344	<2.71	344	3,490	
	Stage 1 AP Quarter 3		Jan-20	N	584	285	3.28	263	0.593	7.34		114	1,990	344	<2.71	344	2,650	J3 J	
	Stage 1 AP Quarter 4		Jun-20	N	584	290	3.41	265	2.37	6.97		131	2,010	365	<8.45	365	3,350	J	
	2nd Semiannual 2020		Oct-20	N	587	271	3.25		4.05	6.68		133	2,030					3,870	J3
	1st Semiannual 2021		Apr-21	N	663	304	2.89		5.55	5.49		147	2,290					4,080	
	2nd Semiannual 2021		Sep-21	N	614	325	2.66		1.76	5.98		144	1,910					4,020	
	1st Semiannual 2022		Apr-22	N	571	365	3.03		1.82	5.39		169	2,140					3,830	
	2nd Semiannual 2022		Oct-22	N	507	248	2.89		0.53	4.52		163	1,730					2,960	
	MW-118		Stage 1 AP Quarter 1	Jul-19	N	600	301	6.16	378	1.02	5.31		146	2,860	360	<2.71	360	4,180	
			Stage 1 AP Quarter 2	Oct-19	N	585	274	4.39	389	1.80	4.15		167	2,480	365	<2.71	365	4,240	
			Stage 1 AP Quarter 3	Jan-20	N	585	313	5.75	J	1.90	4.79		160	2,910	354	<2.71	354	3,630	
		Stage 1 AP Quarter 4	Jun-20	N	585	290	5.63	403	2.27	4.01		168	2,630	364	<8.45	364	4,350	J	
		2nd Semiannual 2020	Oct-20	N	558	262	5.06		2.03	3.07	B	178	2,600					4,640	
		1st Semiannual 2021	Apr-21	N	575	241	4.51		2.29	2.85		192	2,880					4,840	
		2nd Semiannual 2021	Sep-21	N	568	253	4.12		2.06	2.38		186	2,720					4,770	
		1st Semiannual 2022	Apr-22	N	562	265	4.4		2.25	2.09		186	3,180					4,750	
		2nd Semiannual 2022	Oct-22	N	588	245	4.36		1.94	2.04		202	2,630					4,440	

**Table 1 - Summary of Groundwater Analytical Results Screened Using WQCC Standards
Reverse Osmosis Reject Discharge Fields Stage 2 Abatement Plan Work Plan**

Analyte Group:	General Chemistry												
	Analyte:	Calcium	Chloride	Fluoride	Magnesium	Nitrate/Nitrite	Potassium	Sodium	Sulfate	Alkalinity - Bicarbonate	Alkalinity - Carbonate	Total Alkalinity	TDS
	Units:	mg/L	mg/L	mg/L	mg/L	mg/L	mg/L	mg/L	mg/L	mg/L	mg/L	mg/L	mg/L
	CGWSL:	--	250	1.6	--	1.0	--	--	600	--	--	--	1,000
	CGWSL Source:	--	WQCC Dom	WQCC HH	--	WQCC HH ^a	--	--	WQCC Dom	--	--	--	WQCC Dom

Location	Well	Event	Date	Type	Calcium	Chloride	Fluoride	Magnesium	Nitrate/Nitrite	Potassium	Sodium	Sulfate	Alkalinity - Bicarbonate	Alkalinity - Carbonate	Total Alkalinity	TDS			
	MW-119	Stage 1 AP Quarter 1	Jul-19	N	623	443	2.79	288	0.308	1.71	243	2,570	319	<2.71	319	3,980			
		Stage 1 AP Quarter 2	Oct-19	N	625	388	2.36	304	0.174	1.39	217	2,330	331	<2.71	331	3,820			
		Stage 1 AP Quarter 3	Jan-20	N	619	356	2.09	301	0.115	0.964	J	206	2,440	334	<2.71	334	3,860		
		Stage 1 AP Quarter 4	Jun-20	N	636	341	1.70	350	0.184	0.781	J	206	2,590	356	<8.45	356	3,940 J		
		2nd Semiannual 2020	Oct-20	N	641	298	1.39		0.106	0.832	JB	200	V	2,490			4,420		
		1st Semiannual 2021	Apr-21	N	620	278	1.49		0.237	0.69	J	189	V	2,580			4,400		
		2nd Semiannual 2021	Sep-21	N	607	282	B	1.70		0.314	0.786	J	192	2,320			4,360		
		1st Semiannual 2022	Apr-22	N	585	294	1.88		1.430	0.684	J	186	2,730			3,520			
		2nd Semiannual 2022	Oct-22	N	582	263	1.69		0.107	0.724	J	183	2,140			3,930			
		Downgradient	MW-142	Stage 1 AP Quarter 1	Jul-19	N	633	380	2.22	311	0.159	1.74	195	2,610	334	<2.71	334	4,580	
Stage 1 AP Quarter 2	Oct-19			N	645	369	1.87	304	0.0910	J	1.84	188	2,280	343	<2.71	343	4,000		
Stage 1 AP Quarter 3	Jan-20			N	629	363	2.07	301	0.0950	J	1.46	183	2,350	338	<2.71	338	4,090		
Stage 1 AP Quarter 4	Jun-20			N	642	360	2.25	332	0.108	1.16	J	189	2,430	356	<8.45	356	4,020 J		
2nd Semiannual 2020	Oct-20			-															
1st Semiannual 2021	Apr-21			-															
2nd Semiannual 2021	Sep-21			-															
1st Semiannual 2022	Apr-22			-															
2nd Semiannual 2022	Oct-22			-															
	MW-143			Stage 1 AP Quarter 1	Jul-19	N	583	264	1.54	430	0.0980	J	1.78	233	3,170	328	<2.71	328	4,870
		Stage 1 AP Quarter 2	Oct-19	N	550	296	1.2	446	0.127		1.22	B	220	2,970	333	<2.71	333	4,500	
		Stage 1 AP Quarter 3	Jan-20	N	525	263	1.71	422	0.056	J	1.19	209	2,830	329	<2.71	329	4,070		
		Stage 1 AP Quarter 4	Jun-20	N	536	278	1.82	443	<0.0500		0.936	J	214	2,770	348	<8.45	348	4,100 J	
		2nd Semiannual 2020	Oct-20	-															
		1st Semiannual 2021	Apr-21	-															
		2nd Semiannual 2021	Sep-21	-															
		1st Semiannual 2022	Apr-22	-															
		2nd Semiannual 2022	Oct-22	-															
		South RO Field																	
Upgradient	MW-29	Stage 1 AP Quarter 1	Jul-19	N	578	383	2.00	446	<0.985		2.48	384	3,300	503	<2.71	503	4,820		
		Stage 1 AP Quarter 2	Oct-19	N	527	354	1.84	345	<0.0197		2.43	376	2,480	577	<2.71	577	3,910		
		Stage 1 AP Quarter 3	Jan-20	N	416	O1V	344	298	O1V	0.021	JP1	2.46	358	O1V	2,010	542	<2.71	542	3,330
		Stage 1 AP Quarter 4	Jun-20	N	375	395	1.70	285	<0.0500		2.10	361	1,700	564	<8.45	564	3,980		
			Jun-20	FD	379	397	1.74	292	<0.0500		1.95	J	369	1,780	563	<8.45	563	3,360 J	
		2nd Semiannual 2020	Oct-20	N	336	418	1.47		<0.0500		1.9	J	333	V	1,430			3,530	
		1st Semiannual 2021	Apr-21	N	379	457	1.83		0.105		2.06	330	1,580				3,730		
		2nd Semiannual 2021	Sep-21	N	590	502	1.47		0.0504	J	2.77	328	2,170				4,180		
		1st Semiannual 2022	Apr-22	N	378	571	1.68		<0.0500		2.14	317	1,720				3,190		
		2nd Semiannual 2022	Oct-22	N	461	631	1.62		<0.0500		2.52	358	1,670				3,130		
	MW-40	Stage 1 AP Quarter 1	Jul-19	N	588	87.7	1.93	205	<1.97		2.54	104	1,730	309	<2.71	309	2,580		
		Stage 1 AP Quarter 2	Oct-19	N	435	V	68.2	198	V	0.033	J	2.11	98.7	V	1,570	299	<2.71	299	2,610
			Oct-19	FD	428	67.1	2.29	195	<0.0197		1.91	97.6	1,910	294	<2.71	294	2,410		
		Stage 1 AP Quarter 3	Jan-20	N	380	94.1	J	3.38	J	196	<0.0394	UJ	1.81	95.4	<2.71	320	2,370		
			Jan-20	FD	376	83.8	1.85	192	0.658	J	1.60	95.3	1,540	325	<2.71	325	2,620		
		Stage 1 AP Quarter 4	Jun-20	N	365	91.2	1.56	190	<0.0500		1.59	J	93.9	1,410	376	<8.45	376	2,500	
		2nd Semiannual 2020	Oct-20	-															
		1st Semiannual 2021	Apr-21	-															
		2nd Semiannual 2021	Sep-21	-															
		1st Semiannual 2022	Apr-22	-															
2nd Semiannual 2022	Oct-22	-																	

**Table 1 - Summary of Groundwater Analytical Results Screened Using WQCC Standards
Reverse Osmosis Reject Discharge Fields Stage 2 Abatement Plan Work Plan**

Analyte Group:	General Chemistry											
Analyte:	Calcium	Chloride	Fluoride	Magnesium	Nitrate/Nitrite	Potassium	Sodium	Sulfate	Alkalinity - Bicarbonate	Alkalinity - Carbonate	Total Alkalinity	TDS
Units:	mg/L	mg/L	mg/L	mg/L	mg/L	mg/L	mg/L	mg/L	mg/L	mg/L	mg/L	mg/L
CGWSL:	--	250	1.6	--	1.0	--	--	600	--	--	--	1,000
CGWSL Source:	--	WQCC Dom	WQCC HH	--	WQCC HH ^a	--	--	WQCC Dom	--	--	--	WQCC Dom

Location	Well	Event	Date	Type	Calcium	Chloride	Fluoride	Magnesium	Nitrate/Nitrite	Potassium	Sodium	Sulfate	Alkalinity - Bicarbonate	Alkalinity - Carbonate	Total Alkalinity	TDS		
	MW-56	Stage 1 AP Quarter 1	Jul-19	N	525	273	1.20	268	<0.0197	2.21	184	2,180	375	<2.71	375	3,430		
		Stage 1 AP Quarter 2	Oct-19	N	508	286	1.1	261	<0.0197	2.07	155	1,890	363	<2.71	363	3,120		
		Stage 1 AP Quarter 3	Jan-20	N	493	256	1.2	248	<0.0197	2.40	150	1,840	343	<2.71	343	2,850		
		Stage 1 AP Quarter 4	Jun-20	N	504	209	1.11	254	<0.0500	1.91	153	1,840	351	<8.45	351	3,040		
		2nd Semiannual 2020	Jun-20	N	496	219	1.08		<0.0500	1.7	J	142	1,990				3,520	
		1st Semiannual 2021	Apr-21	N	484	211	1.19		0.252	1.8	J	140	1,740				2,860	
		2nd Semiannual 2021	Sep-21	-														
		1st Semiannual 2022	Apr-22	N	388	193	1.15		<0.0500	1.55	J	121	1,400				2,020	
		2nd Semiannual 2022	Oct-22	-														
In Field	MW-114	Stage 1 AP Quarter 1	Jul-19	N	604	219	2.10	239	0.375	3.08	137	2,320	377	<2.71	377	3,000		
		Stage 1 AP Quarter 2	Oct-19	N	611	252	1.50	234	0.613	2.83	136	2,170	376	<2.71	376	3,650		
		Stage 1 AP Quarter 3	Jan-20	N	606	239	2.15	225	0.785	3.25	133	1,980	370	<2.71	370	2,710		
		Stage 1 AP Quarter 4	Jun-20	N	587	241	2.27	211	0.471	2.64	128	1,780	407	<8.45	407	2,920		
		2nd Semiannual 2020	Oct-20	N	528	233	2.07		0.110	2.37	B	119	1,590				3,300	
		1st Semiannual 2021	Apr-21	N	532	180	B	1.98		0.110	2.46		118	1,410			2,960	
		2nd Semiannual 2021	Sep-21	N	466	227		2.32		<0.0500	2.26		109	1,380			2,820	
		1st Semiannual 2022	Apr-22	N	380	114		2.75		<0.0500	1.89	J	97.1	1,320			2,080	
			2nd Semiannual 2022	Oct-22	N	467	408	2.25		<0.0500	2.09		158	1,170			2,670	
	MW-115	Stage 1 AP Quarter 1	Jul-19	N	477	254	2.33	451	<0.0197	0.765	J	217	2,940	410	<2.71	410	4,510	
		Stage 1 AP Quarter 2	Oct-19	N	444	270	2.04	405	0.145	0.608	BJ	195	2,390	417	<2.71	417	3,870	
		Stage 1 AP Quarter 3	Jan-20	N	437	286	2.12	411	0.793	0.812	J	191	2,250	406	<2.71	406	3,670	
		Stage 1 AP Quarter 4	Jun-20	N	476	392	2.16	429	3.78	0.681	J	181	2,260	432	<8.45	432	4,740	
		2nd Semiannual 2020	Oct-20	N	467	406	1.73		3.99	<0.534		179	2,350				4,590	
		1st Semiannual 2021	Apr-21	N	508	357	B	1.54		3.56	0.552	J	212	2,240			4,560	
		2nd Semiannual 2021	Sep-21	N	466	357		1.75		1.85	0.547	J	215	2,170			4,330	
1st Semiannual 2022		Apr-22	N	437	342		1.57		1.60	0.516	J	219	2,220			4,070	Q	
		2nd Semiannual 2022	Oct-22	N	433	306	1.85		0.49	0.363	J	251	1,870			3,390		
MW-116	Stage 1 AP Quarter 1	Jul-19	N	576	265	2.01	289	0.371	2.10		189	2,550	341	<2.71	341	3,700		
		Jul-19	FD	570	266	2.00	289	0.35	2.01		189	2,570	346	<2.71	346	3,490		
	Stage 1 AP Quarter 2	Oct-19	N	567	309	1.99	282	0.403	1.71		187	2,380	336	<2.71	336	3,490		
	Stage 1 AP Quarter 3	Jan-20	N	550	278	1.89	273	0.409	1.53		180	2,270	332	<2.71	332	3,570		
	Stage 1 AP Quarter 4	Jun-20	N	572	321	1.75	297	0.528	1.29	J	188	2,140	341	<8.45	341	4,020	J	
	2nd Semiannual 2020	Oct-20	N	550	260	1.53		0.476	1.14	JB	176	1,920				4,040		
	1st Semiannual 2021	Apr-21	N	588	278	B	1.52		0.636	1.39	J	186	2,080			4,000		
	2nd Semiannual 2021	Sep-21	N	542	283	B	1.38		0.709	1.03	J	174	1,940			3,860		
1st Semiannual 2022	Apr-22	N	534	320	B	1.56		0.505	1.09	J	164	2,300			4,010			
		2nd Semiannual 2022	Oct-22	N	573	321	1.57		0.313	1.03	J	167	1,910			3,980		
Downgradient	MW-125	Stage 1 AP Quarter 1	Jul-19	N	557	298	1.26	392	0.587	1.67	231	2,750	407	<2.71	407	4,380		
		Stage 1 AP Quarter 2	Oct-19	N	553	327	1.08	390	0.544	1.47	229	2,810	406	<2.71	406	3,920		
		Stage 1 AP Quarter 3	Jan-20	N	545	291	1.24	381	0.388	1.89		226	2,560	398	<2.71	398	4,200	
		Stage 1 AP Quarter 4	Jun-20	N	545	278	1.12	392	0.215	1.49	J	231	2,500	421	<8.45	421	4,080	J
		2nd Semiannual 2020	Oct-20	N	541	271	1.1		0.0919	J	1.42	JB	221	2,270			4,350	
		1st Semiannual 2021	Apr-21	N	549	261	B	0.983		0.155	1.36	J	224	2,300			4,440	
		2nd Semiannual 2021	Sep-21	N	519	271	B	1.06		0.0618	J	1.32	J	213	2,210			4,370
		1st Semiannual 2022	Apr-22	N	473	273		1.07		<0.0500	1.19	J	189	2,360			3,330	Q
		2nd Semiannual 2022	Oct-22	N	486	261	1.42	J	<0.0500	1.06	J	206	2,100			7,840		

**Table 1 - Summary of Groundwater Analytical Results Screened Using WQCC Standards
Reverse Osmosis Reject Discharge Fields Stage 2 Abatement Plan Work Plan**

Analyte Group:					General Chemistry												
Location	Well	Event	Date	Type	Calcium	Chloride	Fluoride	Magnesium	Nitrate/Nitrite	Potassium	Sodium	Sulfate	Alkalinity - Bicarbonate	Alkalinity - Carbonate	Total Alkalinity	TDS	
Units:					mg/L	mg/L	mg/L	mg/L	mg/L	mg/L	mg/L	mg/L	mg/L	mg/L	mg/L	mg/L	mg/L
CGWSL:					--	250	1.6	--	1.0	--	--	600	--	--	--	1,000	
CGWSL Source:					--	WQCC Dom	WQCC HH	--	WQCC HH ^a	--	--	WQCC Dom	--	--	--	WQCC Dom	
	MW-144	Stage 1 AP Quarter 1	Jul-19	N	787	222	2.57	220	0.290	2.36	137	2,360	344	<2.71	344	3,740	
		Stage 1 AP Quarter 2	Oct-19	N	687	274	2.36	235	0.201	1.71	143	2,530	313	<2.71	313	3,330	
		Stage 1 AP Quarter 3	Jan-20	N	648	245	2.47	225	0.26	1.63	139	2,300	309	<2.71	309	3,930	
		Stage 1 AP Quarter 4	Jun-20	N	647	257	2.64	238	0.401 J	1.36 J	142	2,120	324	<8.45	324	3,500 J	
		2nd Semiannual 2020	Oct-20	-													
		1st Semiannual 2021	Apr-21	-													
		2nd Semiannual 2021	Sep-21	-													
		1st Semiannual 2022	Apr-22	-													
		2nd Semiannual 2022	Oct-22	-													
	RW-18A	Stage 1 AP Quarter 1	Jul-19	N	521	247	2.10	375	0.256	0.884 J	126	3,090	293	<2.71	293	4,150	
		Stage 1 AP Quarter 2	Oct-19	N	525	235	2.07	384	0.258	<1.00 BJU	124	2,750	298	<2.71	298	3,740	
		Stage 1 AP Quarter 3	Jan-20	N	503	214	2.18	379	0.228	0.854 J	119	2,660	290	<2.71	290	3,830	
		Stage 1 AP Quarter 4	Jun-20	N	525	228	2.13	369	0.549	0.900 J	136	2,320	325	<8.45	325	3,660 J	
		2nd Semiannual 2020	Oct-20	-													
		1st Semiannual 2021	Apr-21	-													
		2nd Semiannual 2021	Sep-21	-													
		1st Semiannual 2022	Apr-22	-													
		2nd Semiannual 2022	Oct-22	-													

Notes and Abbreviations

	The sample for this event was not analyzed for this analyte.
"--"	CGWSL not available for this analyte
X	Reported concentration equal to X was above the CGWSL
<X	Analyte was not detected at reporting limit equal to X. If italicized, reporting limit is greater than CGWSL.
a	Nitrate/Nitrite combined results are compared to the lower WQCC HH standard for Nitrite.
CGWSL	Critical Groundwater Screening Level
CGWSL Source	Critical Groundwater Screening Level Source
EPA	United States Environmental Protection Agency
EPA MCL	EPA Maximum Contaminant Level
FD	Field Duplicate
mg/L	milligrams per Liter
N	Normal
NMAC	New Mexico Administrative Code
WQCC	New Mexico Water Quality Control Commission
WQCC Dom	Groundwater standard for domestic exposure from 20.6.2.3103.B NMAC
WQCC HH	Groundwater standard for human health exposure from 20.6.2.3103.A NMAC
WQCC Irr	Groundwater standard for irrigation use from 20.6.2.3103.C NMAC

Lab Footnotes

B	Analyte reported in associated method blank
J	Reported value is an estimate.
V	Sample concentration too high to evaluate accurate spike recoveries
O1	The analyte failed the method required serial dilution test and/or subsequent post-spike criteria. These failures indicate matrix interference.
P1	RPD value not applicable for sample concentrations less than 5 times the reporting limit.
J3	The associated batch QC was outside the established quality control range for precision.

Data Validation Qualifier

U	Result qualified as not detected at the reporting limit. See data validation report for more detail.
---	--

Table 2 - Summary of Groundwater Analytical Data from Previous Investigations

Stage 1 Abatement Plan for the Reverse Osmosis Reject Discharge Fields

HollyFrontier Navajo Refining LLC

Sample ID*	Date	Aluminum	Arsenic	Barium	Boron	Cadmium	Chromium	Cobalt	Copper	Iron	Lead	Manganese	Mercury	Molybdenum	Nickel	Selenium	Silver	Uranium	Zinc	
		mg/L	mg/L	mg/L	mg/L	mg/L	mg/L	mg/L	mg/L	mg/L	mg/L	mg/L	mg/L	mg/L	mg/L	mg/L	mg/L	mg/L	mg/L	mg/L
		5	0.1	1	0.75	0.01	0.05	0.05	1	1.0	0.05	0.2	0.002	1	0.2	0.05	0.05	0.03	10	
EPA MCL	--	0.01	2	--	0.005	0.1	--	1.3	0.3	0.015	0.05	0.002	--	--	0.05	--	0.03	--		
MW-116	4/3/2018		0.00492	0.00839			<0.000540			0.0594 J	<0.000240	0.0226				0.00743				
(continued)	10/3/2018		0.00304	0.00833			<0.000540			<0.0150	<0.000240	0.0211				0.00475				
MW-117	2/3/2013	0.0289	0.00498 J	0.0235	0.207	< 0.002	< 0.005	0.00256 J	0.0141	< 0.2	< 0.005	0.108	< 0.0002	0.0112	0.00413 J	0.00427 J	< 0.005	0.0263	0.0123	
	5/15/2013	0.0184	0.00367 J	0.0113	0.175	< 0.002	< 0.01	< 0.01	< 0.01	< 0.4	< 0.005	0.00978 J	< 0.0002	0.00664	< 0.01	0.00585 J	< 0.005	0.0247	< 0.01	
	9/4/2013	0.0169	0.00559	0.0108	0.202	< 0.002	< 0.005	< 0.005	< 0.005	< 0.2	< 0.005	0.00502	< 0.0002	0.014	0.00189 J	0.00316 J	< 0.005	0.0224	0.00266 J	
	11/20/2013	0.0298	0.00347 J	0.0108	0.204	< 0.002	< 0.005	< 0.005	0.00345 J	0.11 J	0.00125 J	0.00982	< 0.0002	0.0114	0.00305 J	0.0038 J	< 0.005	0.0182	0.0343	
	4/30/2014		0.00366 J	0.017			0.0021 J			0.78	0.00109 J	0.033				< 0.00100 B				
	11/13/2014		0.0025	0.02			0.0031			0.95	0.00072 J	0.014				0.0077				
	11/13/2014 (Dup)		0.0024	0.016			0.0024			0.71	0.00086 J	0.014				0.0079				
	4/15/2015		0.00249	0.0162			<0.00270			0.492	<0.00120	0.00809				0.0168				
	10/20/2015		0.00351	0.0214			0.00364			1.42	0.00113	0.0149				0.00486				
	4/26/2016		0.00266	0.0186			<0.00270			0.684	<0.00120	0.0103				0.00857				
	10/5/2016		0.00312	0.0249			0.00417			1.57	0.00137	0.0171				0.00403				
	4/26/2017		0.00255	0.0197			0.00209			1.11	0.000901	0.0147				0.00349				
	10/4/2017		0.00238	0.0177			0.00279			1.15	0.000777	0.011				0.00982				
	4/4/2018		0.00236	0.011			0.000952 J			0.2	0.000293 J	0.00405 J				0.0126				
	10/3/2018		0.00224	0.00996			<0.000540			0.0302 J	<0.000240	0.000557 J				0.0121				
MW-118	2/5/2013	< 0.0146 B	0.011	0.0145	0.226	< 0.002	< 0.005	< 0.005	0.00156 J	< 0.2	< 0.005	0.0232	0.000042 J	0.0195	0.00173 J	0.00861	< 0.005	0.037	< 0.005	
	5/15/2013	0.00796 J	0.0146	0.00919	0.23	< 0.002	< 0.005	< 0.005	0.00156 J	< 0.2	< 0.005	< 0.005	< 0.0002	0.0179	0.00184 J	0.0127	< 0.005	0.033	< 0.005	
	9/4/2013	0.00992 J	0.0156	0.0099	0.307	< 0.002	< 0.005	< 0.005	< 0.005	< 0.2	< 0.005	< 0.005	< 0.0002	0.0162	0.00131 J	0.0129	< 0.005	0.0395	< 0.005	
	11/20/2013	0.0103	0.0125	0.00964	0.288	< 0.002	0.00105 J	< 0.005	0.00338 J	0.179 J	0.00107 J	0.00526	< 0.0002	0.0141	0.00214 J	0.00327 J	< 0.005	0.0311	0.0407	
	4/30/2014		0.0109	0.0147			0.00312 J			0.952	0.00266 J	0.0526				< 0.00100				
	11/13/2014		0.012	0.033			0.0032			1.1	0.001 J	0.02				0.0065				
	4/15/2015		0.00977	0.018			<0.00270			0.253	0.00175	0.00454				0.00863				
	10/20/2015		0.0117	0.0131			0.00137			0.155	0.000329	0.00223				0.00509				
	4/26/2016		0.0108	0.0139			<0.00270			0.426 J	<0.00120	0.0048 J				0.00645				
	10/5/2016		0.0117	0.0111			0.000649 JB			0.0658 J	<0.000240	0.000302 J				0.0156				
	4/26/2017		0.0105	0.0091			<0.000540			0.0337 J	<0.000240	0.00067 J				0.0222				
	10/4/2017		0.0109	0.00884			0.000983 J			<0.0150	<0.000240	<0.000250				0.0196				
	4/4/2018		0.00991	0.00943			<0.000540			0.0223 J	0.00043 J	0.000501 J				0.00851				
	10/3/2018		0.0103	0.00867			0.000593 J			0.0156 J	<0.000240	0.000403 J				0.00774				

Released to Imaging: 5/8/2024 4:31:11 PM

Received by OCD: 4/18/2024 2:17:14 PM

Page 34 of 73

Table 2 - Summary of Groundwater Analytical Data from Previous Investigations

Stage 1 Abatement Plan for the Reverse Osmosis Reject Discharge Fields

HollyFrontier Navajo Refining LLC

Sample ID*	Date	Units																	
		Aluminum	Arsenic	Barium	Boron	Cadmium	Chromium	Cobalt	Copper	Iron	Lead	Manganese	Mercury	Molybdenum	Nickel	Selenium	Silver	Uranium	Zinc
		mg/L	mg/L	mg/L	mg/L	mg/L	mg/L	mg/L	mg/L	mg/L	mg/L	mg/L	mg/L	mg/L	mg/L	mg/L	mg/L	mg/L	mg/L
		5	0.1	1	0.75	0.01	0.05	0.05	1	1.0	0.05	0.2	0.002	1	0.2	0.05	0.05	0.03	10
		--	0.01	2	--	0.005	0.1	--	1.3	0.3	0.015	0.05	0.002	--	--	0.05	--	0.03	--
MW-119	2/5/2013	< 0.01 J	0.00294 J	0.00981	0.0987	< 0.002	< 0.005	0.000871 J	0.00309 J	< 0.2	< 0.005	0.0424	< 0.0002	0.0083	0.00174 J	0.00246 J	< 0.005	0.0244	< 0.005
	5/15/2013	0.0296	0.00537	0.00625	0.13	< 0.002	< 0.005	< 0.005	0.00137 J	< 0.2	< 0.005	< 0.005	< 0.0002	0.00745	0.00163 J	0.00506	< 0.005	0.0222	< 0.005
	9/4/2013	0.0113	0.00595	0.00864	0.183	< 0.002	< 0.005	< 0.005	< 0.005	< 0.2	< 0.005	< 0.005	< 0.0002	0.00846	0.0014 J	0.0066	< 0.005	0.0275	
	11/20/2013	0.0149	0.00438 J	0.00973	0.219	< 0.002	0.00116 J	< 0.005	0.00311 J	0.185 J	< 0.005	0.00459 J		0.00861	0.00222 J	0.00144 J	< 0.005	0.0213	0.0241
	4/30/2014		0.0047 J	0.0126			0.00119 J			0.35	< 0.000700	0.0148				< 0.00100 B			
	4/30/2014 (Dup)		0.00446 J	0.0126			0.00114 J			0.341	< 0.000700	0.0136				< 0.00100 B			
	11/13/2014		0.0062	0.06			0.0042			2.3	0.0016 J	0.062				0.0013 J			
	4/15/2015		0.00398	0.0156			<0.00270			0.309	<0.00120	0.0151				<0.00190			
	10/20/2015		0.00417	0.0105			0.000744			0.0886	<0.000240	0.00485				0.00189			
	4/26/2016		0.00315 J	0.00645			<0.00270			<0.0750	<0.00120	<0.00125				0.00259 J			
	10/5/2016		0.00404	0.00979			<0.000540			0.066 J	<0.000240	0.0019 J				0.00334			
	4/26/2017		0.00376	0.00966			<0.000540			0.0438 J	<0.000240	0.00331 J				0.00442			
	10/4/2017		0.00513	0.0108			0.000757 J			0.0324 J	<0.000240	0.00324 J				0.00145 J			
	4/4/2018		0.00392	0.00951			<0.000540			0.0347 J	0.000502 J	0.0025 J				0.00324			
	10/3/2018		0.00462	0.011			<0.000540			<0.0150	<0.000240	0.00375 J				0.00112 J			

Released to Imaging: 5/8/2024 4:31:11 PM

Received by OGD: 4/18/2024 2:17:14 PM

Table 2 - Summary of Groundwater Analytical Data from Previous Investigations

Stage 1 Abatement Plan for the Reverse Osmosis Reject Discharge Fields

HollyFrontier Navajo Refining LLC

Sample ID*	Date	Units	Calcium	Chloride	Fluoride	Nitrate/Nitrite	Potassium	Sodium	Sulfate	TDS
		mg/L	mg/L	mg/L	mg/l	mg/l	mg/L	mg/L	mg/L	mg/l
		WQCC	EPA MCL							
		--	250	1.6	10	--	--	600	1000	
		--	250	4	1	--	--	250	500	
MW-114	2/3/2013		600	158	1.76	1.43	2.86	146	2200	3760
	5/15/2013		576	150	1.91	< 2	2.76	123	1800	3990
	9/5/2013		672	199	1.82	0.055 JH	2.94	138	1950	3870
	11/21/2013		558	422	1.37	< 1	0.678	250	3060	5390
	4/29/2014		611	167	2.07	< 0.150	2.84	152	1920	3620
	11/12/2014		620	200	2.2	0.36	2.7	130	2300	3400
	4/16/2015		570	80.3	1.95	0.0752	2.29	114	2140	3640
	10/20/2015		579	111	1.89	<0.197	2.46	104	2250	2990
	4/29/2016		681	88.6	1.87	0.416 J	2.59	126	1170	3710
	10/4/2016		569	231	2.03	4.69	2.49	89.3	2100	4050
	4/27/2017		599	266	1.78	0.26 JJ5	2.83	131	2350	3480
	10/4/2017		582	157	1.35	2.8	2.83	132	1950	3700
	4/4/2018		665	181	1.97	1.5	2.74	138	2260	3000
	10/3/2018		581	207	1.77	0.395	2.46	117	1050	3730
MW-115	2/3/2013		518	422	1.1	0.821 H	1.78	199	2790	4960
	5/15/2013		511	373	1.18	< 2	0.78	206	2490	5510
	5/15/2013 (Dup)		495	364	1.15	< 2	0.766	201	2420	4990
	9/4/2013		622	530	0.845	0.174 JH	0.782	247	2900	6130
	11/21/2013		606	428	1.36	< 1	0.709	261	3090	5370
	4/29/2014		569	222	1.29	< 0.150	0.645	227	2470	4880
	11/12/2014		690 V	500	1.5	< 0.02	0.72 J	340	3000	5700
	4/16/2015		546	464	2.42	0.0333	0.425	385	3510	6200
	10/20/2015		532	326	2.8	<0.197	0.578	320	3640	4640
	4/29/2016		2410	153	1.93	0.375 J	2.64	1290	2020	5390
	10/4/2016		541	382	2.69	0.113 B	0.395	144	2750	4990
	4/27/2017		394	304	1.51	<0.197	0.514	183	2770	4190
	10/4/2017		450	249	1.01	0.042 J	0.558	213	2910	4480
	4/4/2018		455	262	1.76	0.075 J	0.58 J	232	2830	3420
	10/3/2018		397	231	1.47	0.325	0.549 J	191	1720	4410
MW-116	2/3/2013		624	389	1.31 J	1.37 J	1.06	206	2250	3650
	5/16/2013		578	330	1.19	< 2	1.38	194	2080	4480
	9/4/2013		588	344	1.17	0.418 H	1.21	235	2180	4440
	9/4/2013 (Dup)		631	339	1.11	0.45 H	1.22	230	2140	4470
	11/20/2013		606	331	1.61	0.457 J	1.3	235	2470	4570
	11/20/2013 (Dup)		616	331	1.51	0.487 J	1.37	235	2470	4210
	4/29/2014		607	221	1.43	2.86	1.39	241	2160	4520
	11/12/2014		580	240	1.7	0.74	1.6	230	2200	3700
	4/16/2015		534	131	2.28	0.0753	3.57	92.1	1800	3300
	10/20/2015		644	223	2.8	<0.197	5.67	145	2280	3800
	4/29/2016		719	500	1.33	0.473 J	1.63	259	3300	4580
	10/5/2016		569	196	2.91	0.048 JB	4.26	114	2040	3500
	4/26/2017		501	270	2	0.258 J	2.22	154	2060	3450
	10/3/2017		614	233	2.72	1.4	4.47	147	2080	3160

Released to Imging: 5/8/2024 4:31:11 PM

Received by OCD: 4/18/2024 2:17:14 PM

Page 36 of 73

Table 2 - Summary of Groundwater Analytical Data from Previous Investigations

Stage 1 Abatement Plan for the Reverse Osmosis Reject Discharge Fields

HollyFrontier Navajo Refining LLC

Sample ID*	Date	Units	Calcium	Chloride	Fluoride	Nitrate/Nitrite	Potassium	Sodium	Sulfate	TDS
		mg/L	mg/L	mg/L	mg/l	mg/l	mg/L	mg/L	mg/L	mg/l
		WQCC	EPA MCL							
		--	250	1.6	10	--	--	600	1000	
		--	250	4	1	--	--	250	500	
MW-116	4/3/2018		592	198	2.55	0.851	3.16	154	2040	2950
(continued)	10/3/2018		557	226	1.15	0.727	1.18	170	2150	4090
MW-117	2/3/2013		568	154	2.73	< 0.1 H	6.92	176	2310	3910
	5/15/2013		524	137	2.29	< 2	4.37	160	2010	4260
	9/4/2013		550	71	2.8	< 0.03	8.92	118	2020	3970
	11/20/2013		556	92.4	3.95	< 1	7.54	115	2190	4150
	4/30/2014		646	97	3.03	< 0.150	9.29	167	2140	4980
	11/13/2014		610	96	3	0.65	5.2	110	2000	3000
	11/13/2014 (Dup)		640	96	2.4	0.64	5	98	2200	3300
	4/15/2015		613	87.2	3.79	0.372	5.97	102	2220	3670
	10/20/2015		478	55.4	3.4	0.779	6.44	109	1690	2980
	4/26/2016		554	94.4	3.45	0.349	5.82	112	2060	3390
	10/5/2016		592	272	3.57	0.137 BJ6	6.9	115	2240	3590
	4/26/2017		548	245	3.33	0.266 J	6.5	96.7	2090	3640
	10/4/2017		559	216	2.05	0.196	5.82	105	<0.0774	3450
	4/4/2018		604	124	3.2	0.207	6.3	111	1070	2920
10/3/2018		577	327	2.78	0.102	6.12	105	1940	3500	
MW-118	2/5/2013		563	296	5.16	2.39	7.95	218	2450	4610
	5/15/2013		530	287	5.39	2.09	7.2	229	2250	5090
	9/4/2013		543	132	4.48	0.325 H	7.69	215	2310	4550
	11/20/2013		532	90.1	6.78	< 1	6.92	163	2470	4640
	4/30/2014		732	92.3	5.58	< 0.150	6.15	134	2190	5200
	11/13/2014		670	160	4.9 J6	0.98	6.2	140	2700	3700
	4/15/2015		601	767	4.14	1.7	5.3	153	2510	3960
	10/20/2015		583	86.6	5.13	0.622	5.64	162	2690	3960
	4/26/2016		573	189	5.86	1.57	4.8	152	2480	3950
	10/5/2016		559	131	6.47	6.71	5.92	164	2640	4450
	4/26/2017		544	175	5.98	8.51	5.06	139	2630	3830
	10/4/2017		550	192	4.2	6.27	5.72	118	2890	3780
	4/4/2018		607	292	5.55	1.21	4.86	136	2480	3300
10/3/2018		559	259	5.06	1.88	4.98	136	1730	4120	

Table 2 - Summary of Groundwater Analytical Data from Previous Investigations

Stage 1 Abatement Plan for the Reverse Osmosis Reject Discharge Fields

HollyFrontier Navajo Refining LLC

Sample ID*	Date	Units	Calcium	Chloride	Fluoride	Nitrate/Nitrite	Potassium	Sodium	Sulfate	TDS
		mg/L	mg/L	mg/L	mg/l	mg/l	mg/L	mg/L	mg/L	mg/l
		WQCC	250	1.6	10	--	--	600	1000	
EPA MCL	250	4	1	--	--	250	500			
MW-119	2/5/2013	494	116	2.36	2.35	0.87	127	2090	3670	
	5/15/2013	491	118	2.43	1.91 J	0.794	120	1970	4030	
	9/4/2013	635	244	2.28	0.228 H	0.993	133	1940	4030	
	11/20/2013	551	185	3.17	< 1	1.1	98.8	2210	4130	
	4/30/2014	680	235	2.61	0.176 J	1.13	140	1980	4200	
	4/30/2014 (Dup)	655	216	2.62	0.174 J	1.08	136	1830	4140	
	11/13/2014	670	49	2.6	< 0.02	1.8	77	2300	3200	
	4/15/2015	590	48.2	1.99	0.292	0.232	54.5	2040	3030	
	10/20/2015	624	152	2.65	0.437	0.985	86.3	2290	3500	
	4/26/2016	595	191	2.5	0.518 J	0.614	101	1900	3330	
	10/5/2016	619	280	2.91	0.189 B	0.991	132	2010	3690	
	4/26/2017	587	290	2.86	<0.197	0.965	123	2420	3650	
	10/4/2017	612	268	2.77	<0.0197	1.27	172	2240	3750	
	4/4/2018	616	251	2.75	0.288	1.1	177	2240	2620	
	10/3/2018	596	439	2.56	0.061 J	1.49	225	1390	4200	

Notes and Definitions:

Blue shaded, bold font indicates result is above the lower of the WQCC standard or MCL

< X = Not detected at a detection limit of X

Italics font indicates detection limit exceeds the lowest SSL

"--" in WQCC or MCL cell means that standard is not published for that analyte

Blank cells mean that analyte was not analyzed in that sample

* Analytical results shown for 2013 metals are dissolved concentrations; total concentrations of metals are reported for 2014 through 2018

B = Analyte detected in associated method blank

H = Sample analyzed outside of hold time

J = Estimated value reported below detection limit

J5 = The sample matrix interfered with the ability to make any accurate determination; spike value is high.

J6 = Spike value low; matrix interfered with accuracy

MCL = Maximum Contaminant Level published by USEPA

mg/L = milligrams per liter

USEPA = United States Environmental Protection Agency

WQCC = Water Quality Control Commission standard (New Mexico)

FIGURES



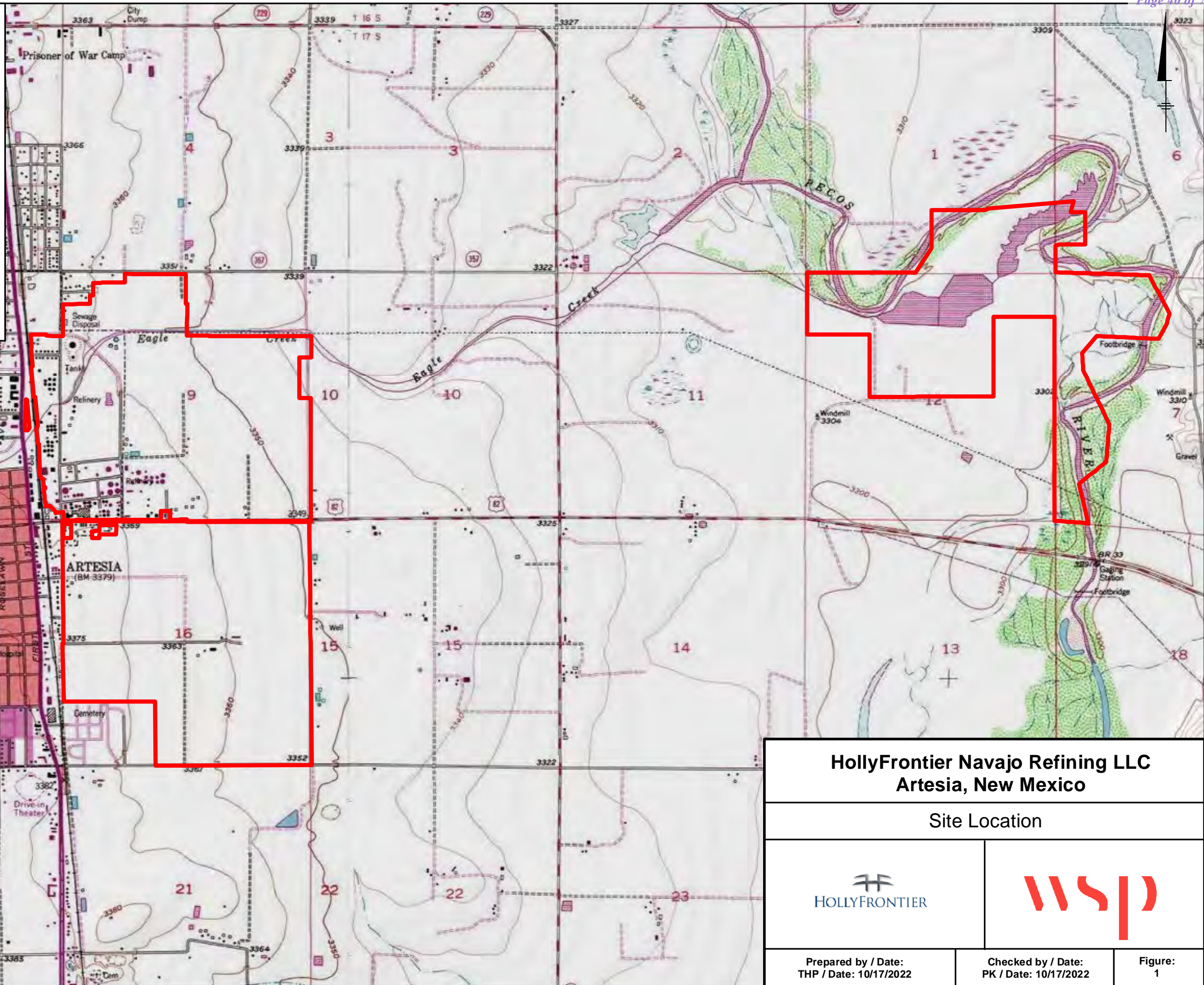
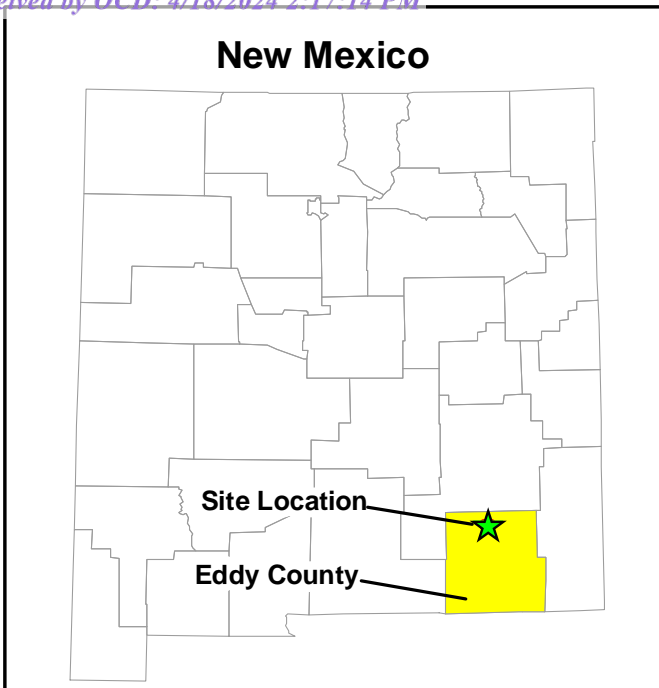

Legend

Property Boundary

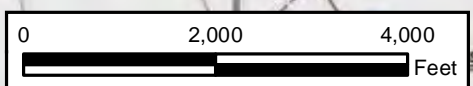

HollyFrontier Navajo Refining LLC Artesia, New Mexico		
Site Location		
Prepared by / Date: THP / Date: 10/17/2022	Checked by / Date: PK / Date: 10/17/2022	Figure: 1

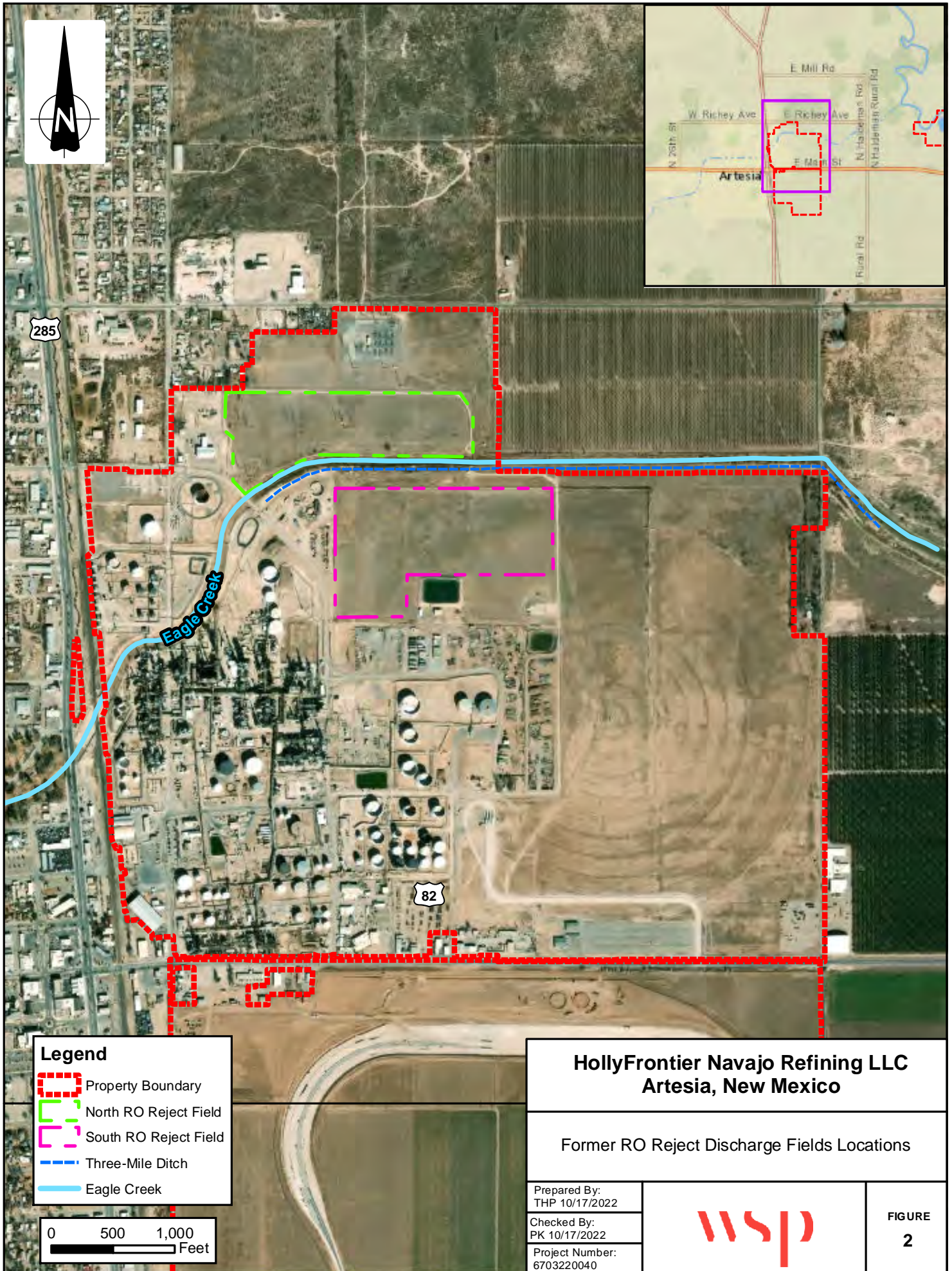

Legend

- Property Boundary
- North RO Reject Field
- South RO Reject Field
- Three-Mile Ditch
- Eagle Creek

0 500 1,000
Feet

**HollyFrontier Navajo Refining LLC
Artesia, New Mexico**

Former RO Reject Discharge Fields Locations

Prepared By:
THP 10/17/2022

Checked By:
PK 10/17/2022

Project Number:
6703220040



**FIGURE
2**

DB: ALB PM: PK Path: G:\Holly Frontier Navajo\mxd\8_10_2022\RO Monitoring Well & Soil Moisture Probe Locations.mxd: 10/18/2022: 11:06:29 AM

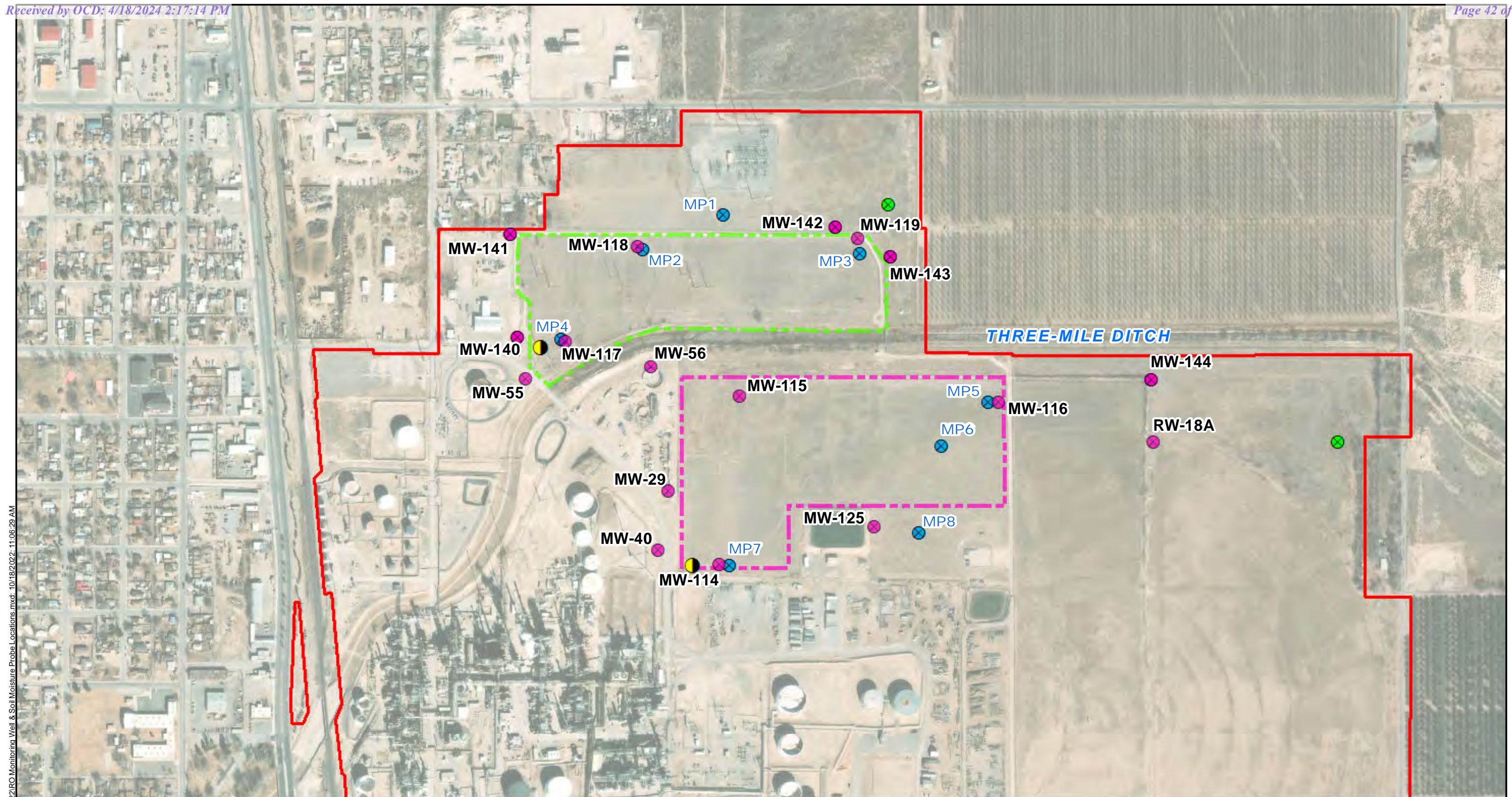

Legend

- Property Boundary
- North RO Reject Discharge Field
- South RO Reject Discharge Field
- Moisture Probes
- Monitoring Well
- Former Discharge Point
- Proposed Well

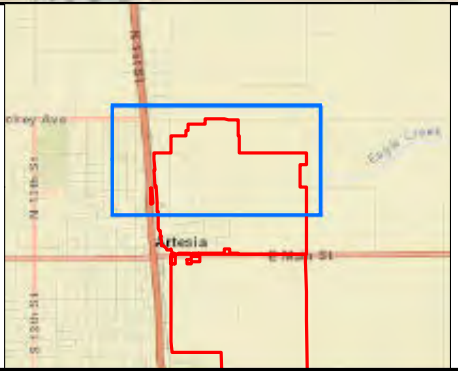
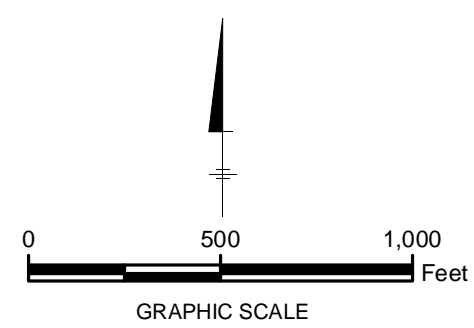

**HollyFrontier Navajo Refining LLC
Artesia, New Mexico**

Former RO Reject Discharge
Fields Monitoring Well and
Soil Moisture Probe Locations

Prepared By:
THP 10/18/2022

Checked By:
PK 10/18/2022

Project Number:
6703220040



FIGURE
3

APPENDIX

A

VERTICAL DISTRIBUTION OF PRIMARY SOIL COCS



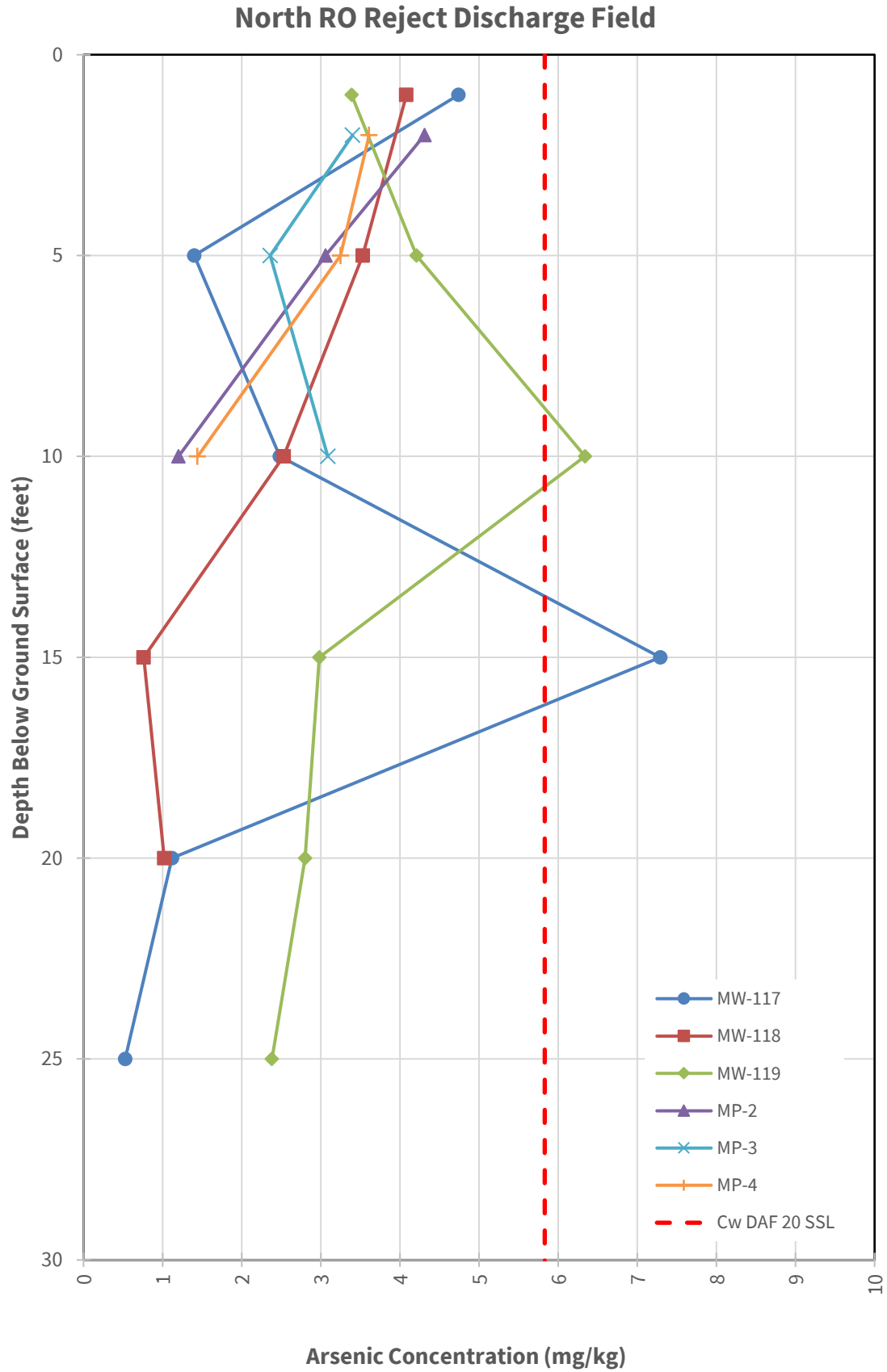

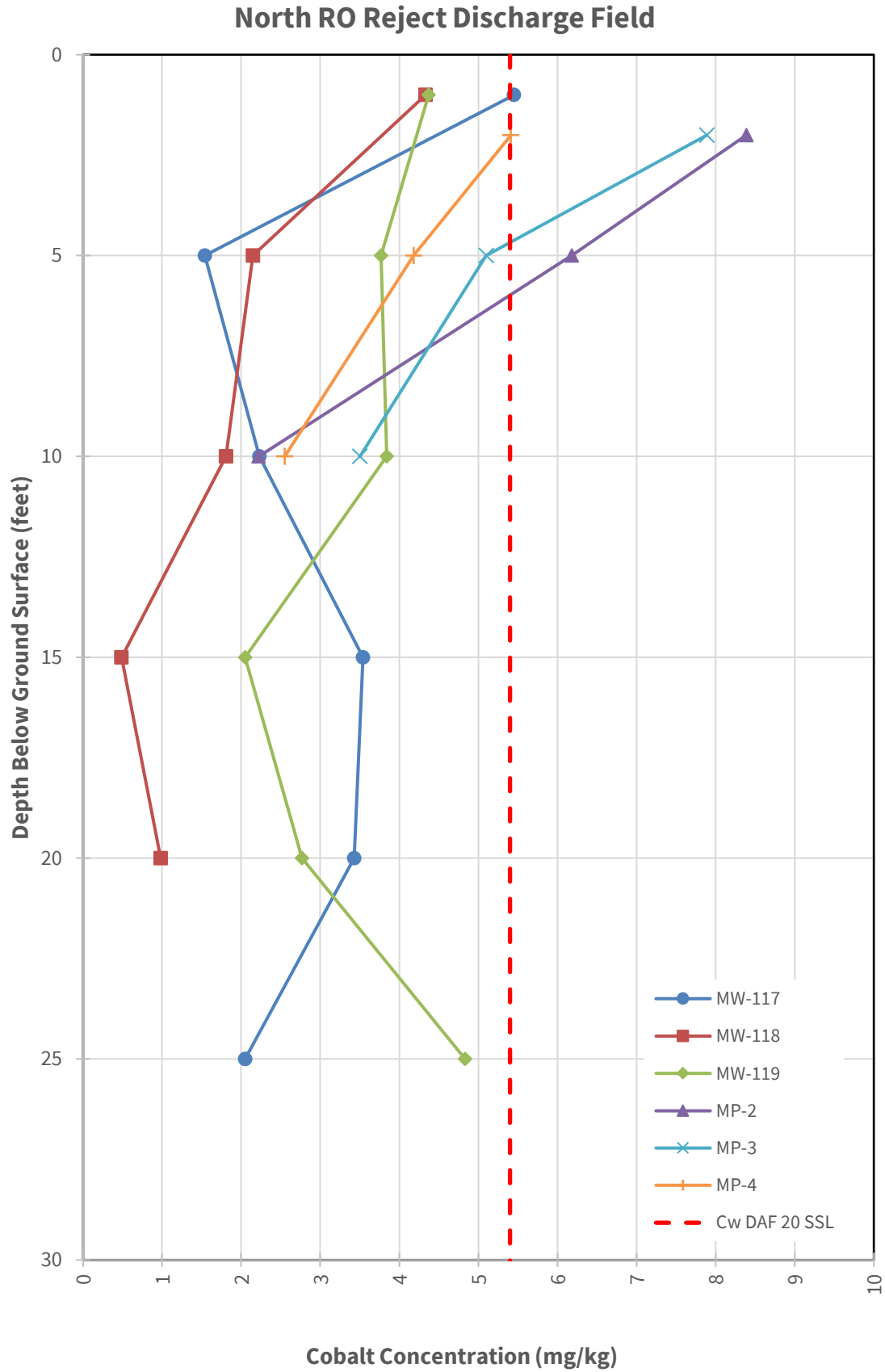

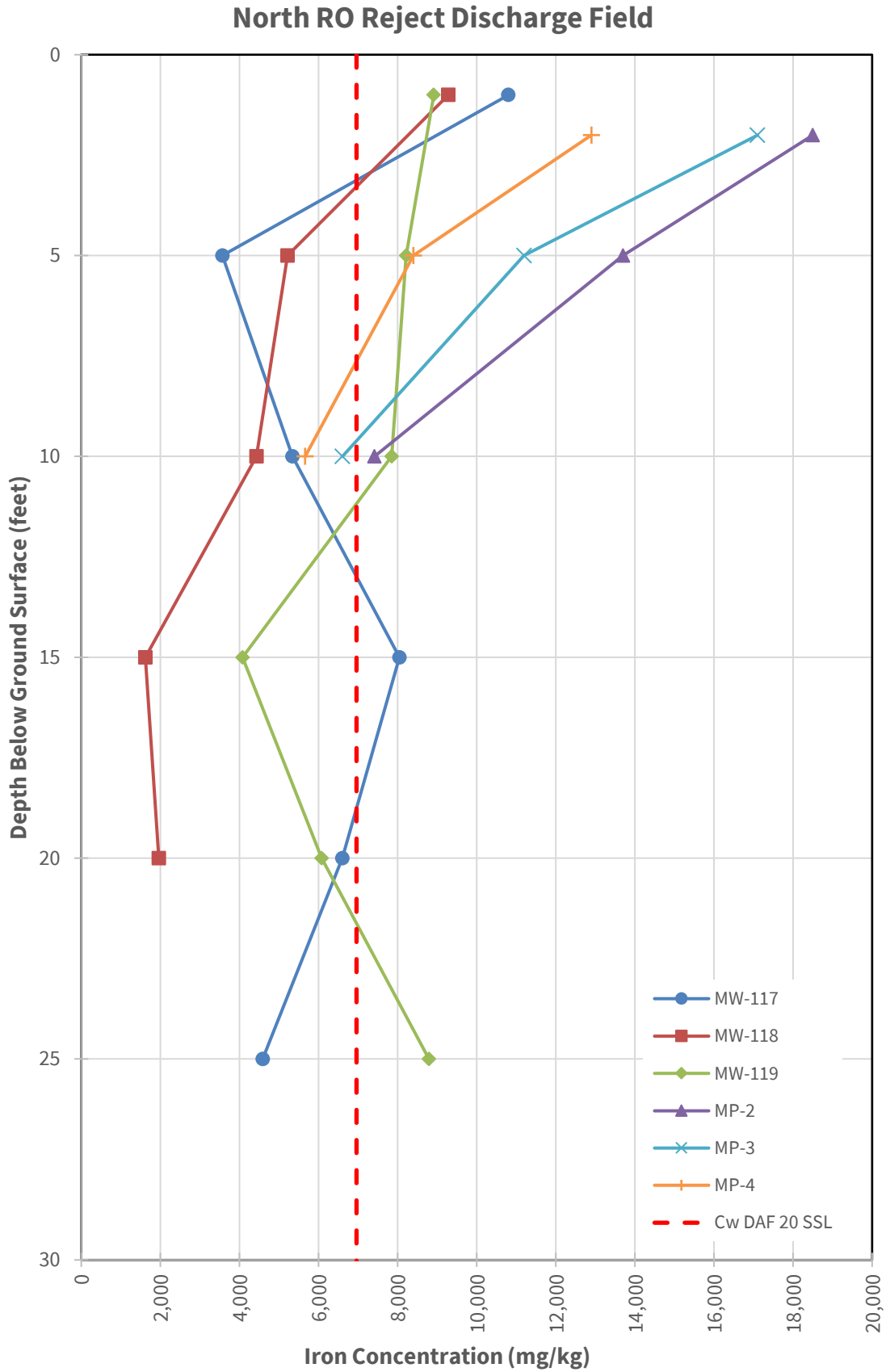

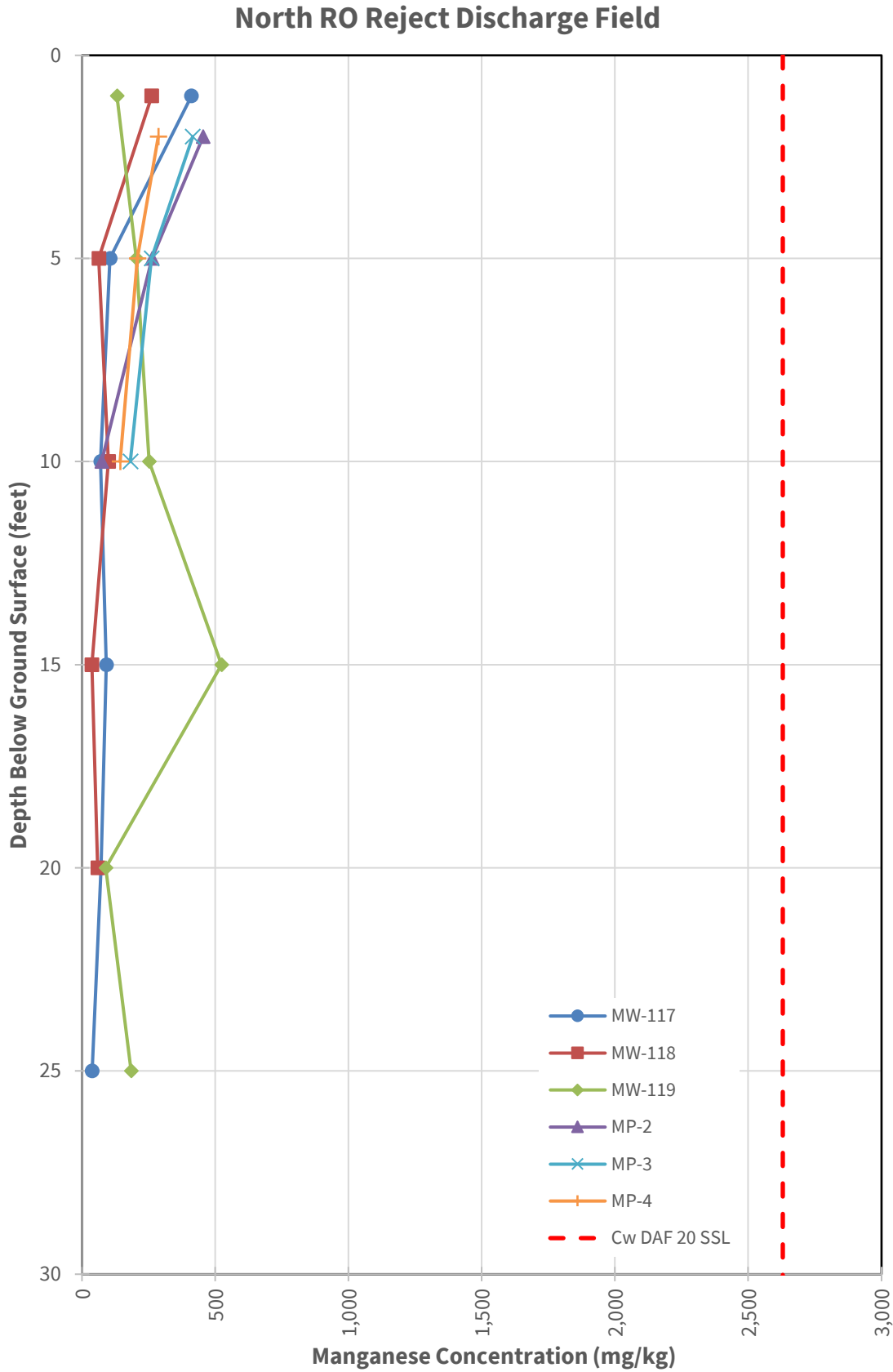

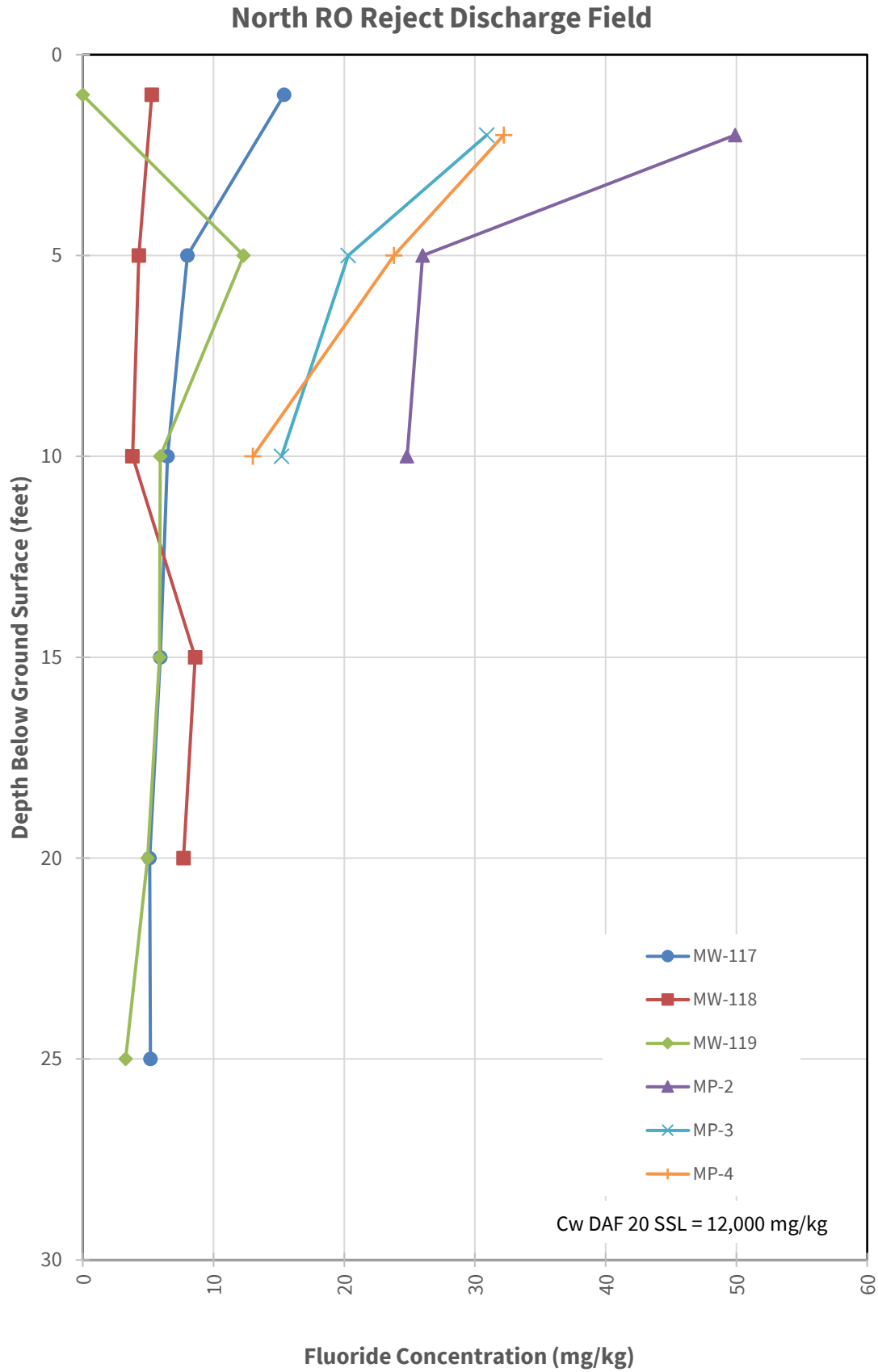

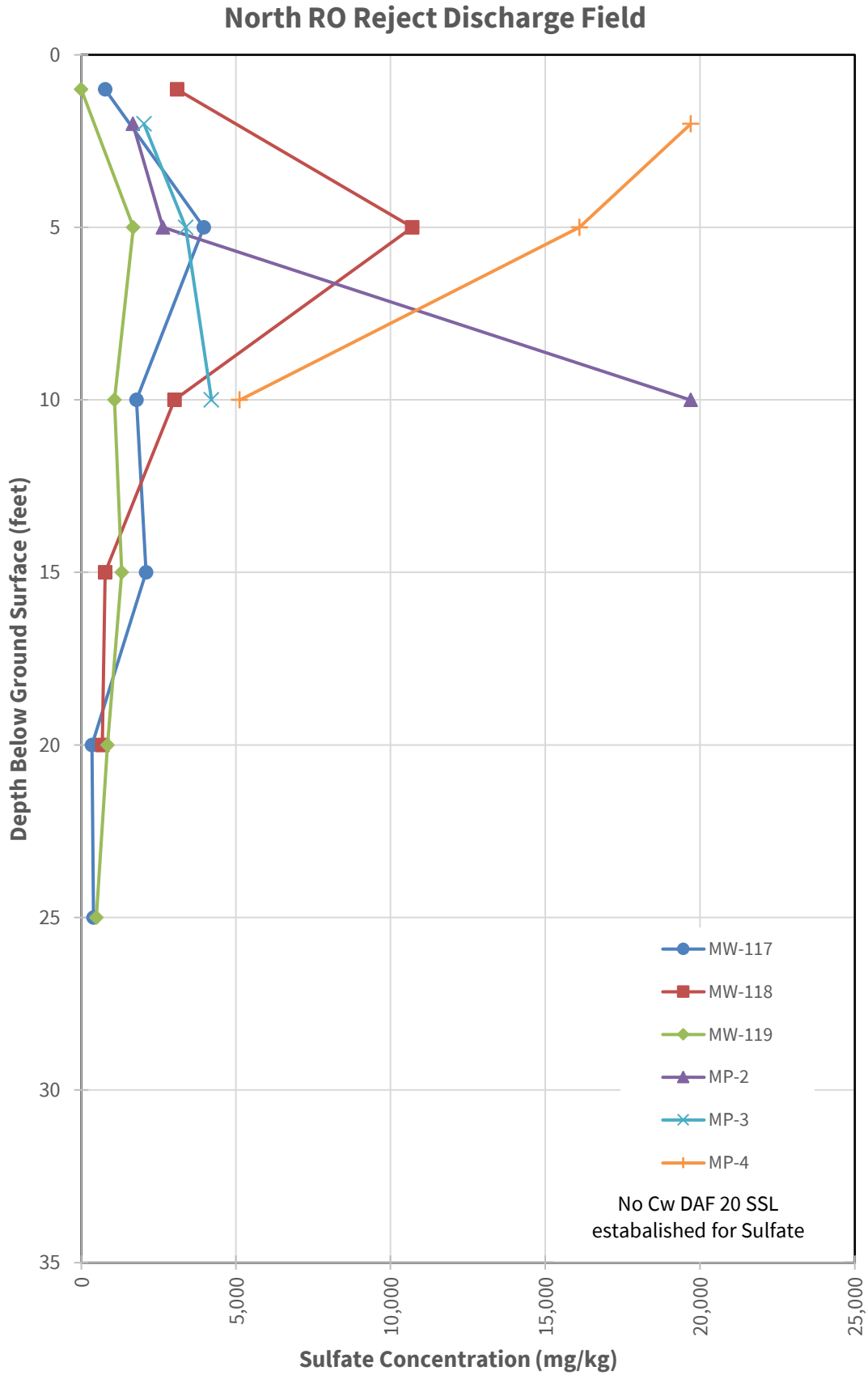

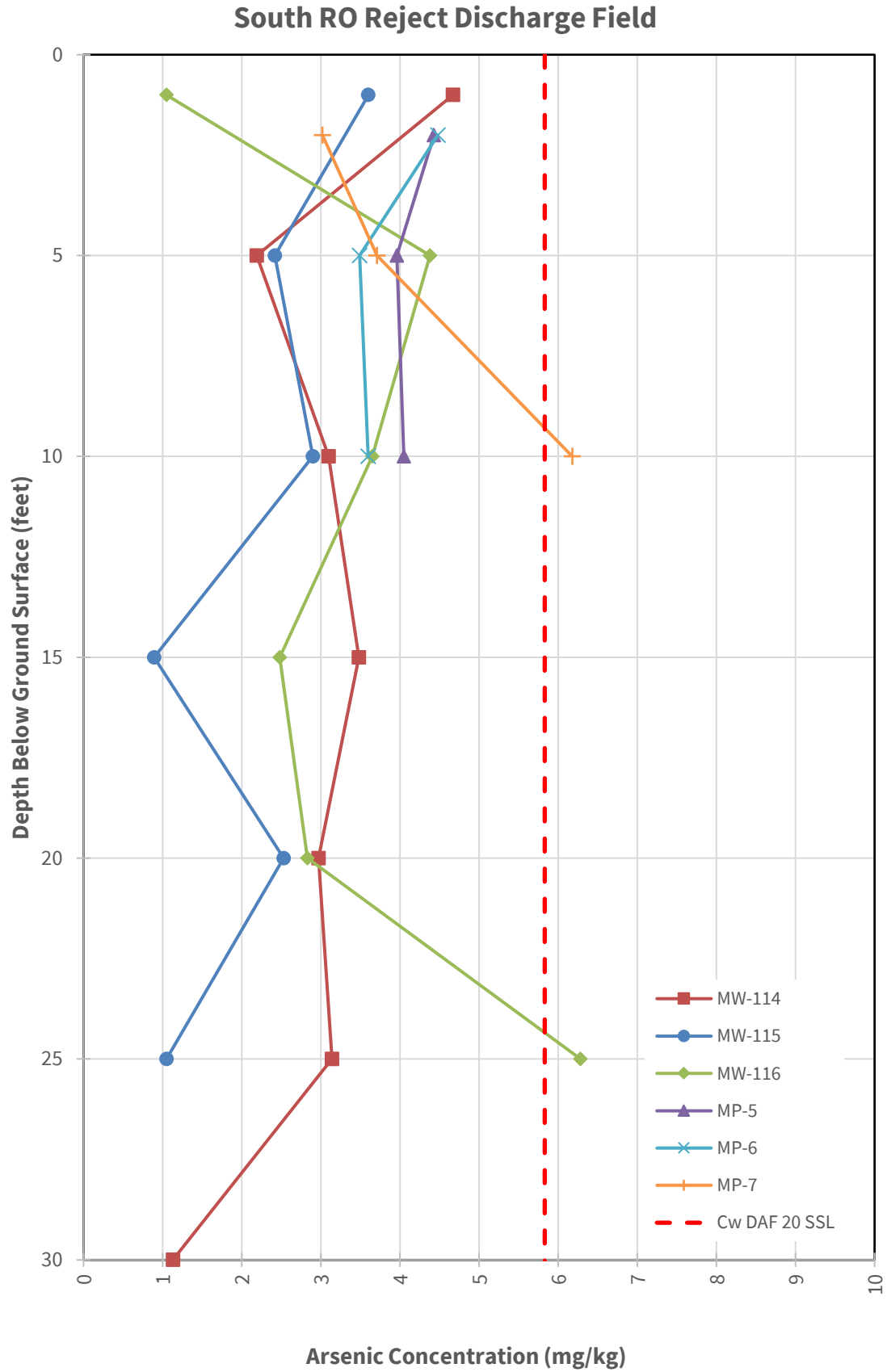

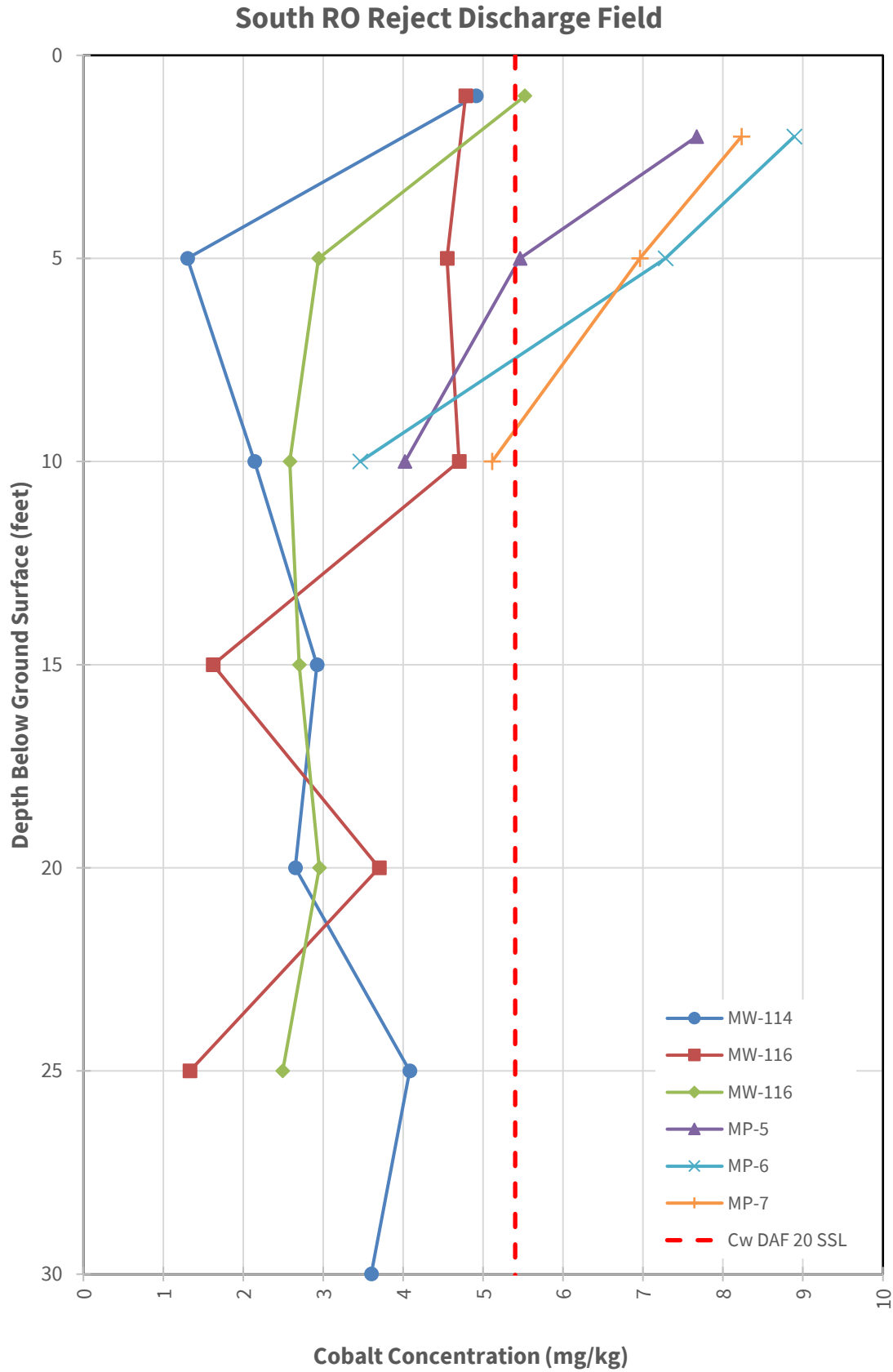

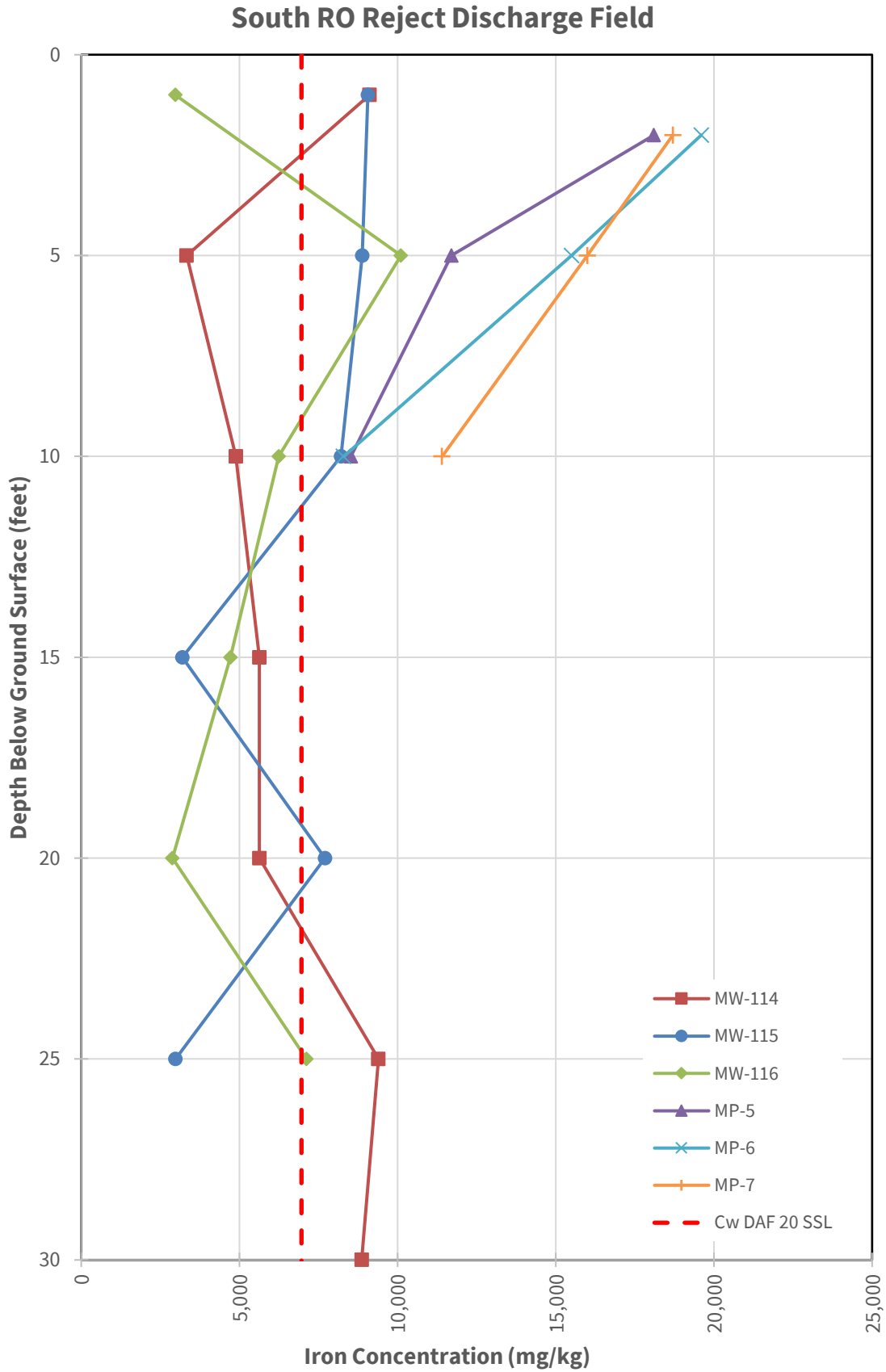

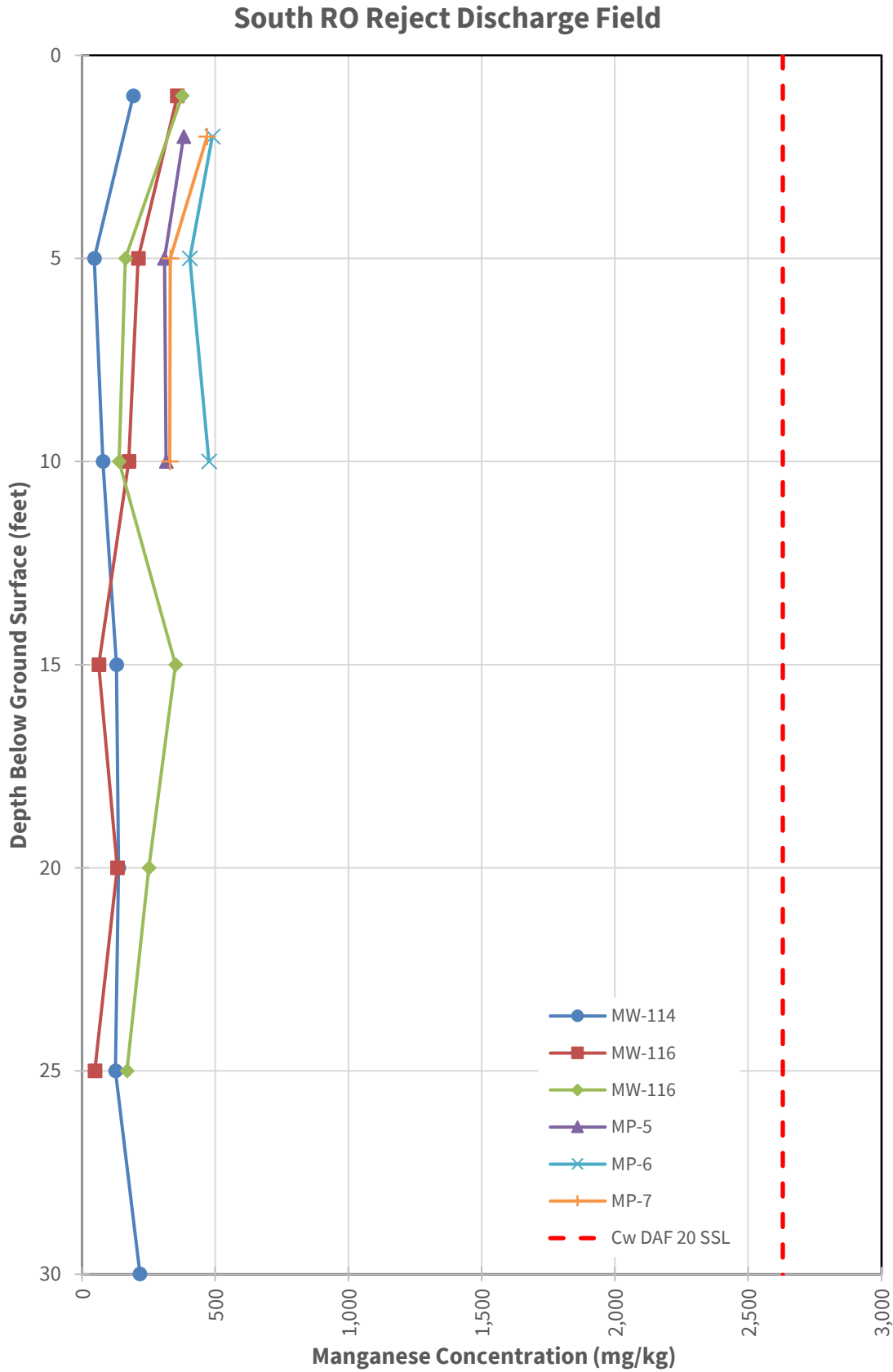

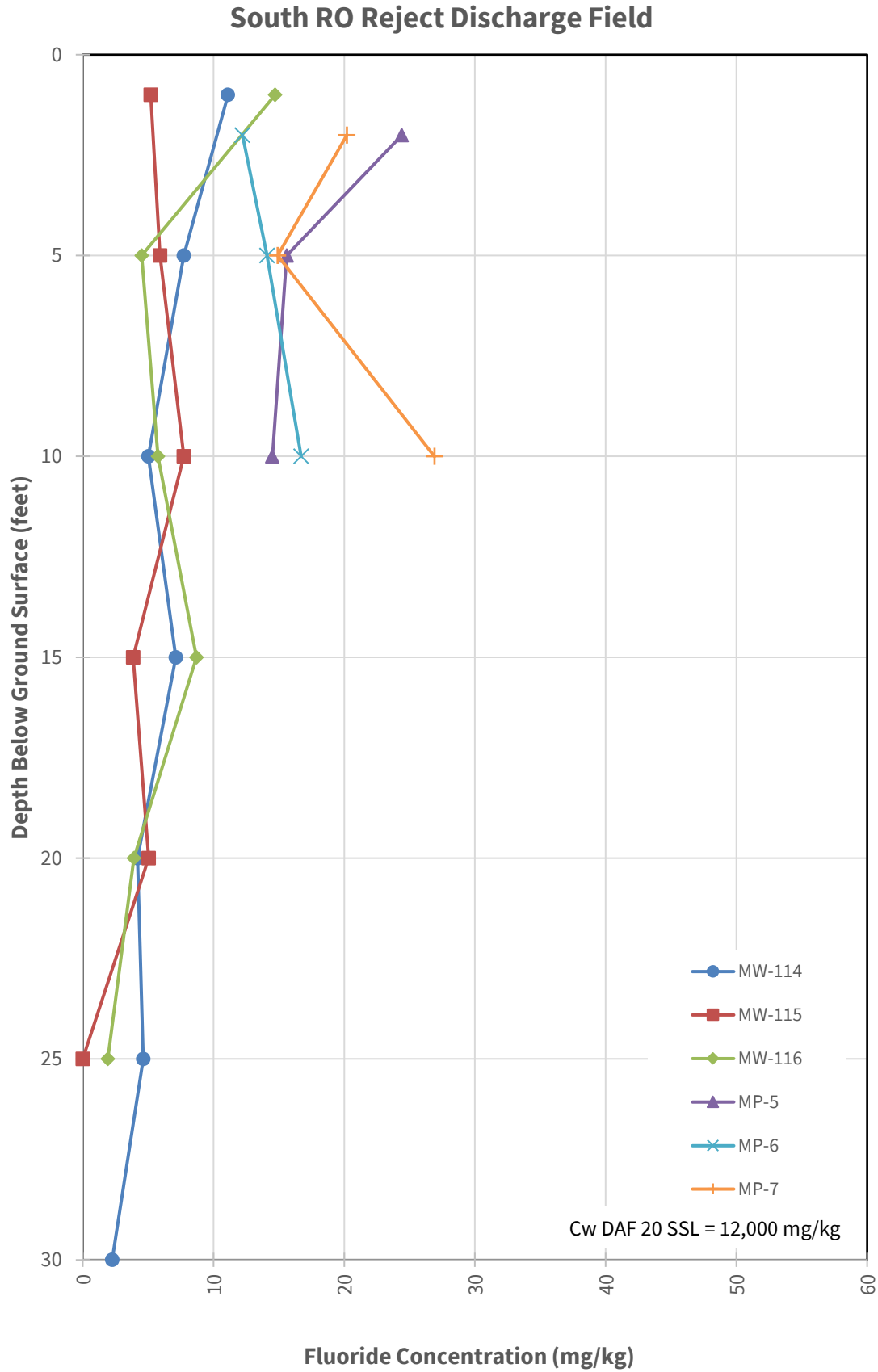

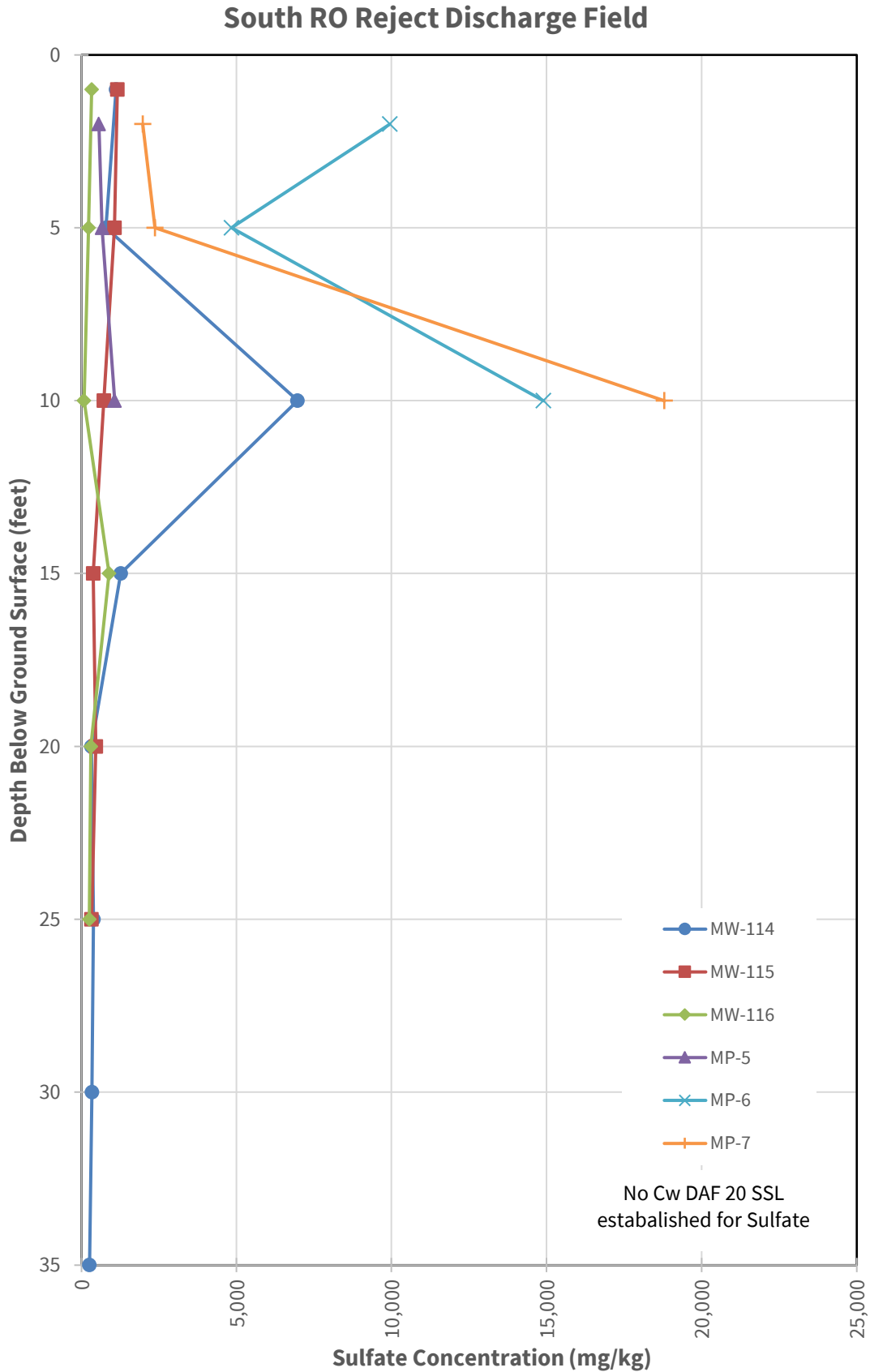

APPENDIX

B

SHALLOW SATURATED ZONE
POTENTIOMETRIC SURFACE MAPS AND
CRITICAL GROUNDWATER SCREENING
LEVEL EXCEEDANCE MAPS FOR
CONSTITUENTS OF CONCERN:

FALL 2020

SPRING 2021

FALL 2021

SPRING 2022

FALL 2022

SPRING 2023

FALL 2023

Note: Figures in this appendix are exact duplicates from the respective annual groundwater reports and the figure numbers are not sequential.

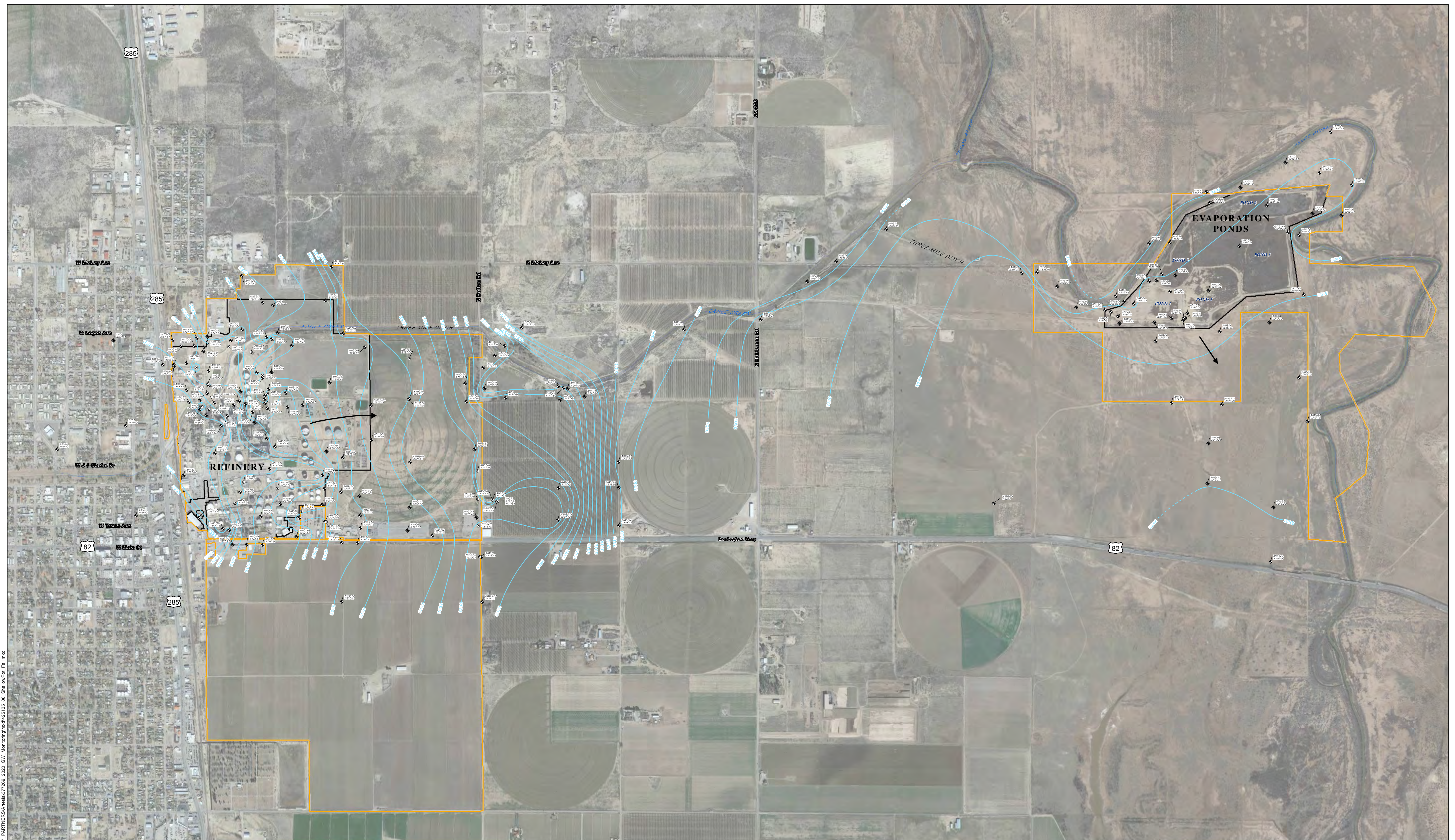

Document Path: S:\PROJECTS\HOLLY ENERGY PARTNERS\Artesia\377265_2020_GW_Monitoring\mxd\25135_06_ShallowPot_Plot.mxd

AERIAL IMAGERY SOURCE: GOOGLE EARTH PRO AND THEIR DATA PARTNERS, 1/29/2019

LEGEND

- Monitoring Well Symbol: MONITORING WELL
- Recovery Well Symbol: RECOVERY WELL
- Arrow Symbol: GROUNDWATER FLOW DIRECTION
- Dashed Line Symbol: SHALLOW SATURATED ZONE POTENTIOMETRIC SURFACE CONTOURS - DASHED WHERE INFERRED (FEET ABOVE MEAN SEA LEVEL)
- Blue Line Symbol: GROUNDWATER ELEVATION DEPRESSED LOCALLY DUE TO RECOVERY PUMP
- Black Line Symbol: FENCELINE
- Orange Line Symbol: HFNR PROPERTY BOUNDARY (FENCELINE SHOWN WHERE COINCIDENT)
- 3337.67 Symbol: GROUNDWATER ELEVATION (FEET)

0 800 1,600
Feet
1 IN = 800 FT

NOTE:

1. GROUNDWATER ELEVATION WAS NOT MEASURED BECAUSE WELL IS NOT IN GAUGING PROGRAM, WELL COULD NOT BE LOCATED, OR WELL WAS DAMAGED.
2. WELL WAS DRY AT TIME OF GAUGING.
3. GROUNDWATER ELEVATION NOT MEASURED DUE TO PUMP INSTALLED IN WELL.
4. GROUNDWATER ELEVATION NOT AVAILABLE DUE TO PSH IN WELL TO TOTAL DEPTH.
5. GROUNDWATER ELEVATION NOT USED IN POTENTIOMETRIC SURFACE CONTOURING



SHALLOW SATURATED ZONE
POTENTIOMETRIC SURFACE MAP
2020 SECOND SEMIANNUAL EVENT

2020 ANNUAL GROUNDWATER REPORT
HOLLY FRONTIER WALSALO REFINING, LLC
ARTESIA REFINERY, EDDY COUNTY, NEW MEXICO

AUTHOR: MHORN	SAVED: 2/4/2021	MXD: 425135_06_ShallowPot_Fall
---------------	-----------------	--------------------------------

TRC 505 E. HUNTLAND DR.
SUITE 250
AUSTIN, TX 78752
PH: 512-329-6080

FIGURE
6

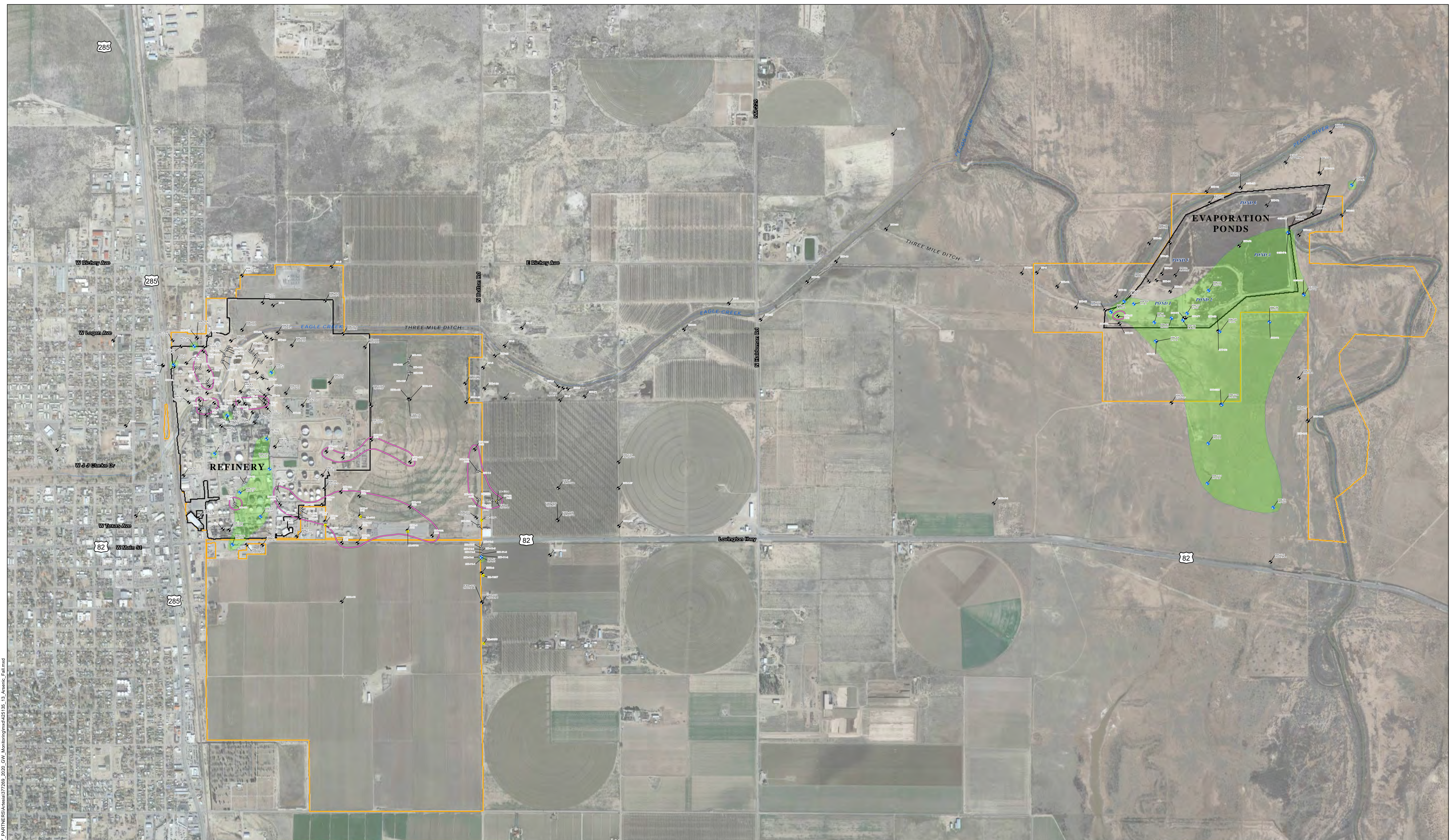

Document Path: S:\PROJECTS\HOLLY ENERGY PARTNERS\Artesia\377265_2020_GW_Monitoring\mxd\25135_13_Arsenic_Fall.mxd
 AERIAL IMAGERY SOURCE: GOOGLE EARTH PRO AND THEIR DATA PARTNERS, 3/12/2016.

LEGEND

- ◆ MONITORING WELL EXCEEDS SCREENING LEVELS
- ◆ MONITORING WELL
- IRRIGATION WELL
- RECOVERY WELL
- 0.0249 ARSENIC CONCENTRATION
- < 0.00368 ARSENIC NOT DETECTED ABOVE METHOD DETECTION LIMIT
- NAW-19 WELL NOT SAMPLED
- PSH PHASE-SEPARATED HYDROCARBON PRESENT IN WELL (≥0.03 FEET THICK)
- ARSENIC CRITICAL GROUNDWATER SCREENING LEVEL EXCEEDANCE AREA (CONCENTRATION > 0.01 mg/L)
- FENCELINE
- HFNR PROPERTY BOUNDARY (FENCELINE SHOWN WHERE COINCIDENT)
- PHASE-SEPARATED HYDROCARBON (PSH)

NOTES:

1. ALL CONCENTRATIONS ARE IN MILLIGRAMS PER LITER (mg/L).
2. J = CONCENTRATION QUALIFIED AS AN ESTIMATED VALUE.

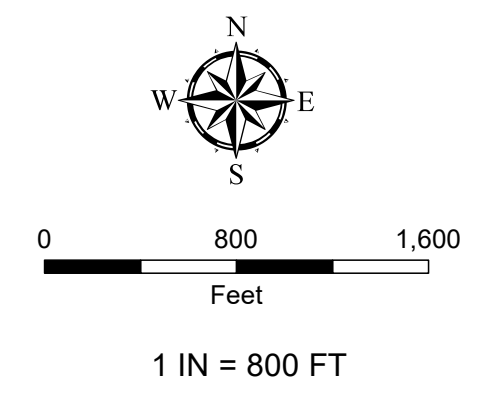

ARSENIC CRITICAL GROUNDWATER SCREENING LEVEL EXCEEDANCE MAP 2020 SECOND SEMIANNUAL EVENT

2020 ANNUAL GROUNDWATER REPORT
 HOLLY FRONTIER NAVAJO REFINING LLC
 ARTESIA REFINERY, EDDY COUNTY, NEW MEXICO

AUTHOR: MHOHN	SAVED: 2/4/2021	MXD: 425135_13_Arsenic_Fall
TRC	505 E. HUNTLAND DR. SUITE 250 AUSTIN, TX 78752 PH: 512-329-6080	FIGURE 13

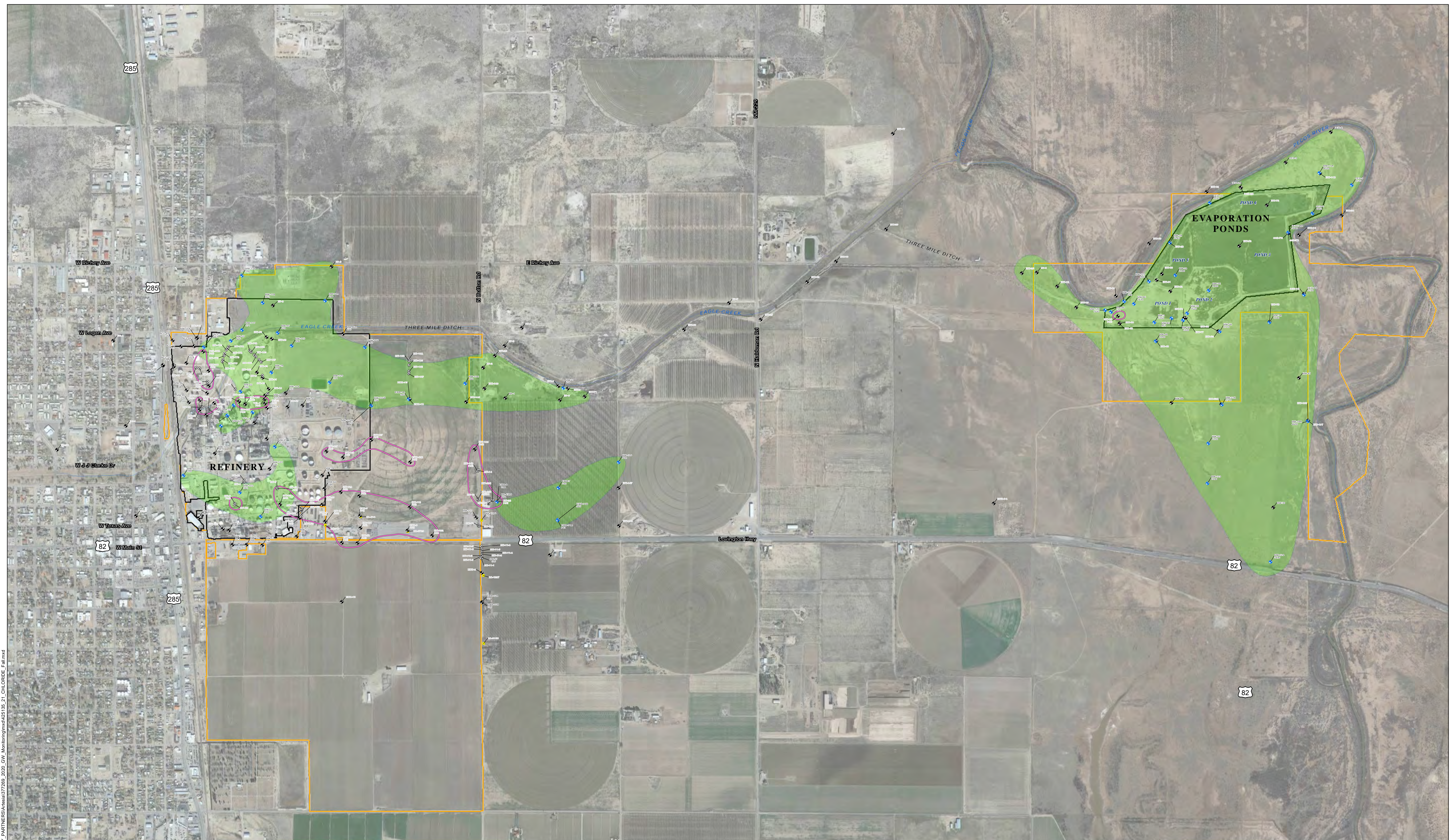

Document Path: S:\PROJECTS\HOLLY ENERGY PARTNERS\Artesia\377265_2020_GW_Monitoring\mxd\25135_21_CHLORIDE_Full.mxd
 AERIAL IMAGERY SOURCE: GOOGLE EARTH PRO AND THEIR DATA PARTNERS, 12/29/2019

LEGEND

- ◆ MONITORING WELL EXCEEDS SCREENING LEVELS
- ◆ MONITORING WELL
- IRRIGATION WELL
- RECOVERY WELL
- 188 CHLORIDE CONCENTRATION WELL NOT SAMPLED
- KW18-13
- P PHASE-SEPARATED HYDROCARBON PRESENT IN WELL (≥ 0.03 FEET THICK)
- CHLORIDE CRITICAL GROUNDWATER SCREENING LEVEL EXCEEDANCE AREA (CONCENTRATION > 250 mg/L)
- FENCELINE
- HFNR PROPERTY BOUNDARY (FENCELINE SHOWN WHERE COINCIDENT)

P PHASE-SEPARATED HYDROCARBON (PSH)

NOTES:
 1. ALL CONCENTRATIONS ARE IN MILLIGRAMS PER LITER (mg/L).

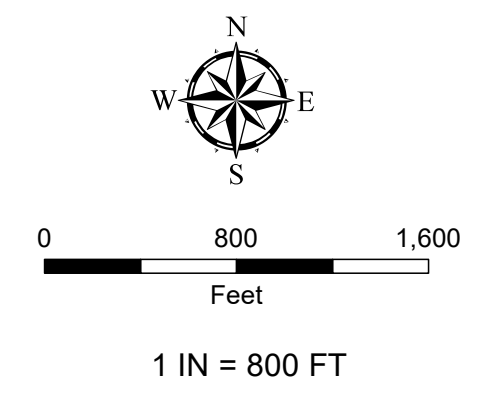

CHLORIDE CRITICAL GROUNDWATER SCREENING LEVEL EXCEEDANCE MAP 2020 SECOND SEMIANNUAL EVENT

2020 ANNUAL GROUNDWATER REPORT
 HOLLY FRONTIER NAVAJO REFINING LLC
 ARTESIA REFINERY, EDDY COUNTY, NEW MEXICO

AUTHOR: MHOEN	SAVED: 2/3/2021	MXD: 425135_21_CHLORIDE_Full
		FIGURE 21

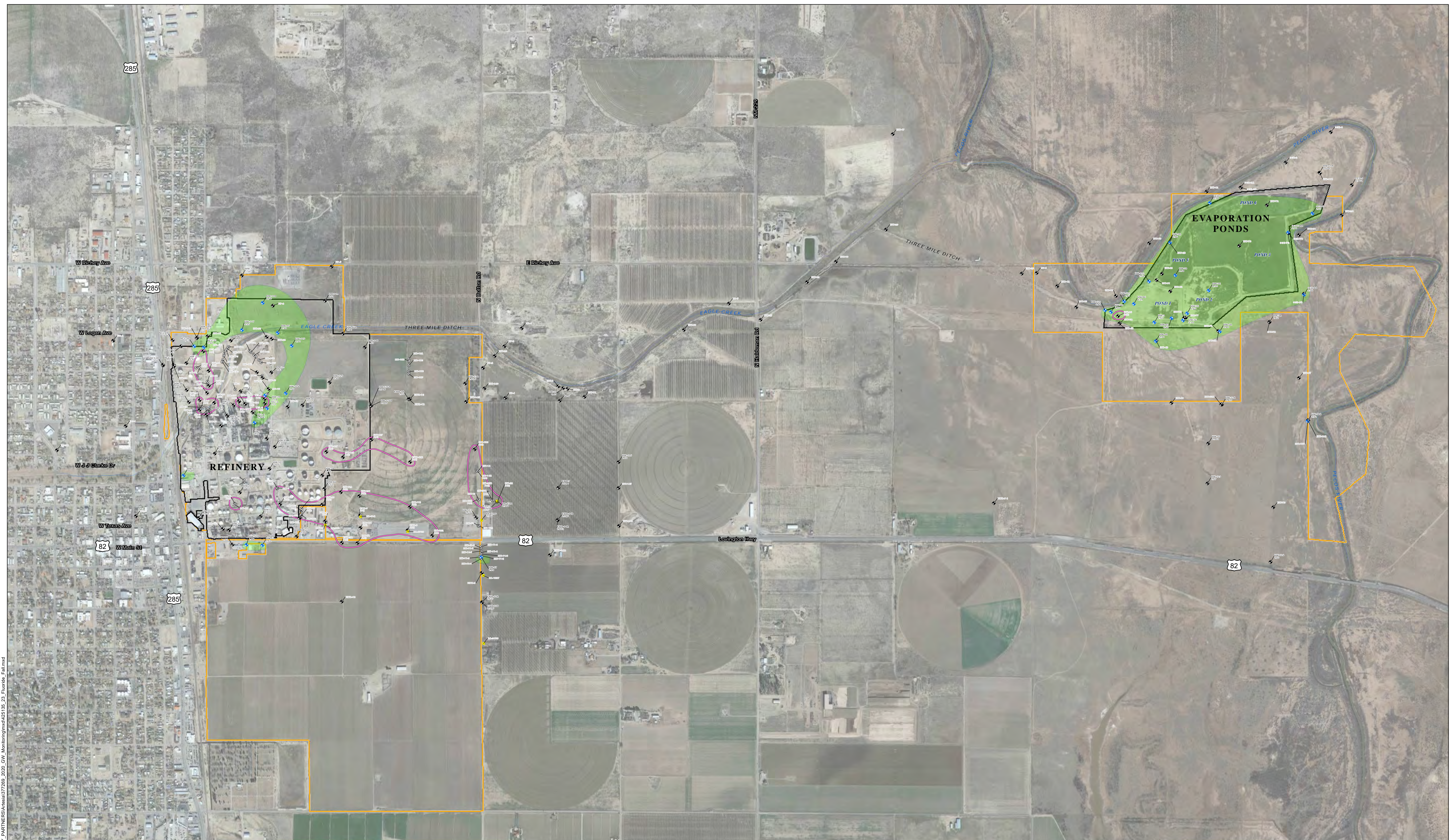

Document Path: S:\PROJECTS\HOLLY ENERGY PARTNERS\Areas\377265_2020_GW_Monitoring\mxd\25135_23_Fluoride_Fall.mxd

AERIAL IMAGERY SOURCE: GOOGLE EARTH PRO AND THEIR DATA PARTNERS, 12/29/2019

LEGEND

- MONITORING WELL EXCEEDS SCREENING LEVELS
- MONITORING WELL
- IRRIGATION WELL
- RECOVERY WELL
- PHASE-SEPARATED HYDROCARBON (PSH)
- PHASE-SEPARATED HYDROCARBON (PSH) PRESENT IN WELL (≥ 0.03 FEET THICK)
- FLUORIDE CRITICAL GROUNDWATER SCREENING LEVEL EXCEEDANCE AREA (CONCENTRATION > 1.6 mg/L)
- FENCELINE
- HFNR PROPERTY BOUNDARY (FENCELINE SHOWN WHERE COINCIDENT)
- 1.73 FLUORIDE CONCENTRATION
- WELL NOT SAMPLED
- MW-112

NOTES:

- ALL CONCENTRATIONS ARE IN MILLIGRAMS PER LITER (mg/L).
- J = CONCENTRATION QUALIFIED AS AN ESTIMATED VALUE.

LEGEND

- NORTH
- 0 800 1,600 Feet
- 1 IN = 800 FT

NEW MEXICO

FLUORIDE CRITICAL GROUNDWATER SCREENING LEVEL EXCEEDANCE MAP 2020 SECOND SEMIANNUAL EVENT

2020 ANNUAL GROUNDWATER REPORT
 HOLLYFRONTIER HAVAJO REFINING LLC
 ARTESIA REFINERY, EDDY COUNTY, NEW MEXICO

AUTHOR: MHOHN	SAVED: 2/3/2021	MXD: 425135_23_Fluoride_Fall
---------------	-----------------	------------------------------

TRC 505 E. HUNTLAND DR. SUITE 250 AUSTIN, TX 78752 PH:512-329-6080

FIGURE 23

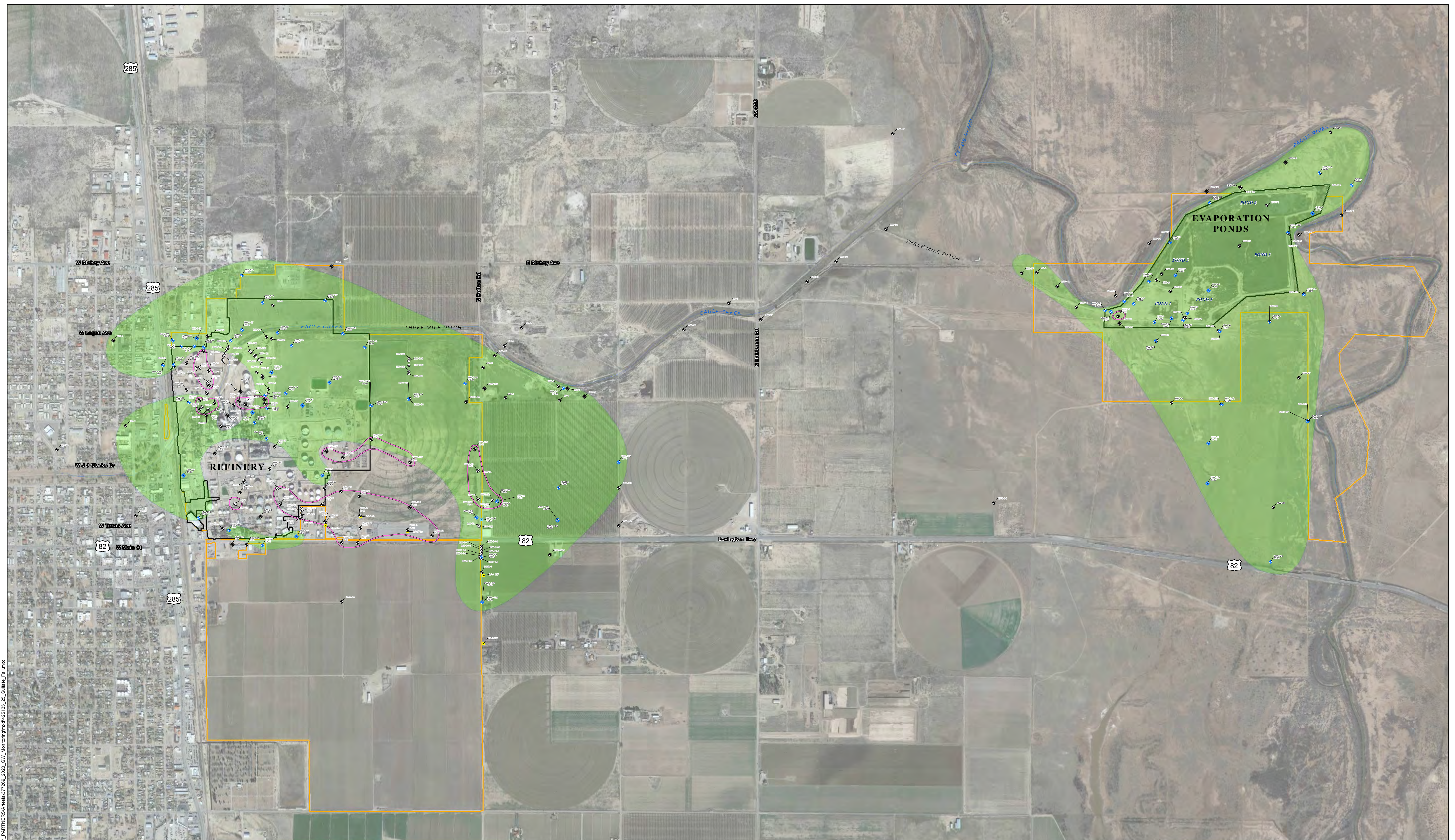

- LEGEND**
- ◆ MONITORING WELL EXCEEDS SCREENING LEVELS
 - MONITORING WELL
 - ◆ IRRIGATION WELL EXCEEDS SCREENING LEVELS
 - IRRIGATION WELL
 - RECOVERY WELL

- 980 Sulfate Concentration
- MW-103 WELL NOT SAMPLED
- PSH PHASE-SEPARATED HYDROCARBON PRESENT IN WELL (≥ 0.03 FEET THICK)
- Sulfate Critical Groundwater Screening Level Exceedance Area (Concentration > 600 mg/L)
- FENCELINE
- HFNR PROPERTY BOUNDARY (FENCELINE SHOWN WHERE COINCIDENT)

PSH PHASE-SEPARATED HYDROCARBON (PSH)

- NOTES:**
1. ALL CONCENTRATIONS ARE IN MILLIGRAMS PER LITER (mg/L).
 2. J = CONCENTRATION QUALIFIED AS AN ESTIMATED VALUE.

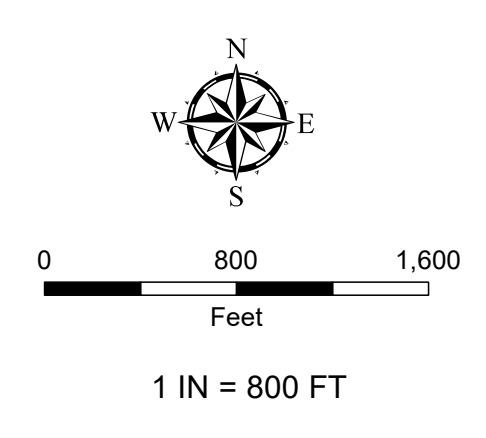

SULFATE CRITICAL GROUNDWATER SCREENING LEVEL EXCEEDANCE MAP 2020 SECOND SEMIANNUAL EVENT

2020 ANNUAL GROUNDWATER REPORT
 HOLLYFRONTIER HAVAJO REFINING LLC
 ARTESIA REFINERY, EDDY COUNTY, NEW MEXICO

AUTHOR: MHORN SAVED: 2/3/2021 MOD: 4/25/24_25_Sulfate_Fall

	505 E. HUNTLAND DR. SUITE 250 AUSTIN, TX 78752 PH:512-329-6080	FIGURE 25

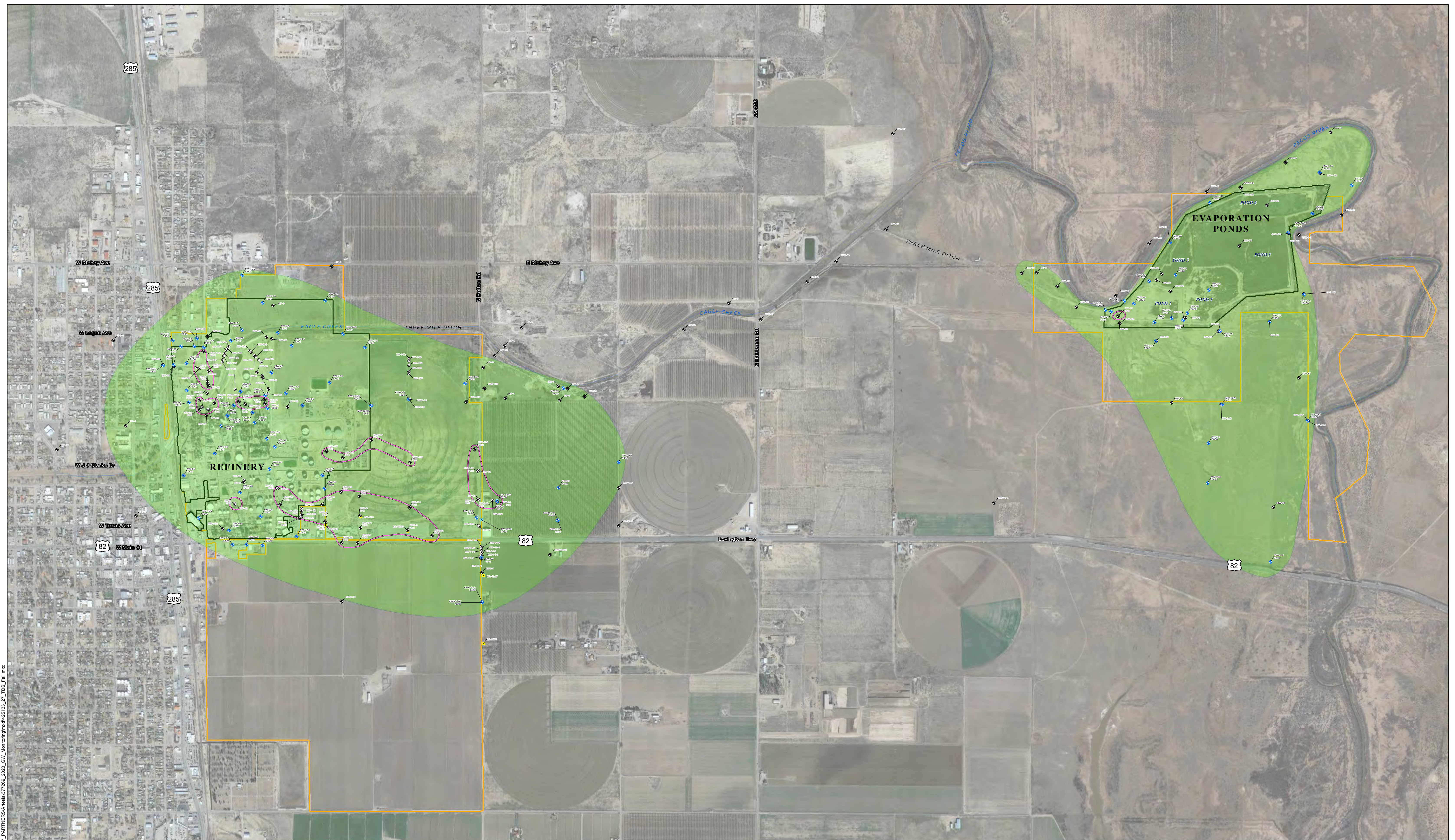

Document Path: S:\PROJECTS\HOLLY ENERGY PARTNERS\Artesia\377265_2020_GW_Monitoring\mxd\25195_27_TDS_Fall.mxd
 AERIAL IMAGERY SOURCE: GOOGLE EARTH PRO AND THEIR DATA PARTNERS, 12/29/2019

LEGEND

	MONITORING WELL EXCEEDS SCREENING LEVELS		MONITORING WELL
	IRRIGATION WELL EXCEEDS SCREENING LEVELS		IRRIGATION WELL
	RECOVERY WELL		TOTAL DISSOLVED SOLIDS CONCENTRATION WELL NOT SAMPLED
	PHASE-SEPARATED HYDROCARBON (PSH)		PHASE-SEPARATED HYDROCARBON PRESENT IN WELL (≥ 0.03 FEET THICK)
	TOTAL DISSOLVED SOLIDS CRITICAL GROUNDWATER SCREENING LEVEL EXCEEDANCE AREA (CONCENTRATION > 1000 mg/L)		TOTAL DISSOLVED SOLIDS CRITICAL GROUNDWATER SCREENING LEVEL EXCEEDANCE AREA (CONCENTRATION > 1000 mg/L)
	FENCELINE		FENCELINE
	HFNPR PROPERTY BOUNDARY (FENCELINE SHOWN WHERE COINCIDENT)		

NOTES:
 1. ALL CONCENTRATIONS ARE IN MILLIGRAMS PER LITER (mg/L).

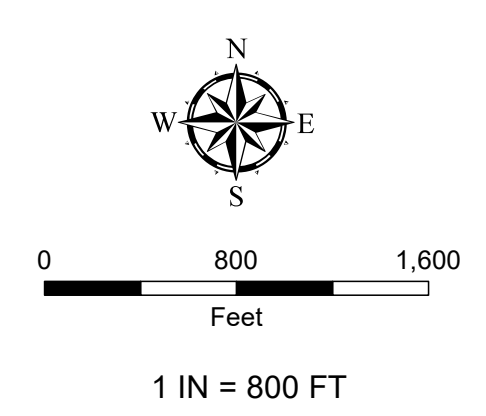

TOTAL DISSOLVED SOLIDS CRITICAL GROUNDWATER SCREENING LEVEL EXCEEDANCE MAP
 2020 SECOND SEMIANNUAL EVENT
 2020 ANNUAL GROUNDWATER REPORT
 HOLLYFRONTIER NAVAJO REFINING LLC
 ARTESIA REFINERY, EDDY COUNTY, NEW MEXICO

AUTHOR: MHORN	SAVED: 2/3/2021	MXD: 425135_27_TDS_Fall
---------------	-----------------	-------------------------

TRC 505 E. HUNTLAND DR. SUITE 250 AUSTIN, TX 78752 PH:512-329-6080

FIGURE 27

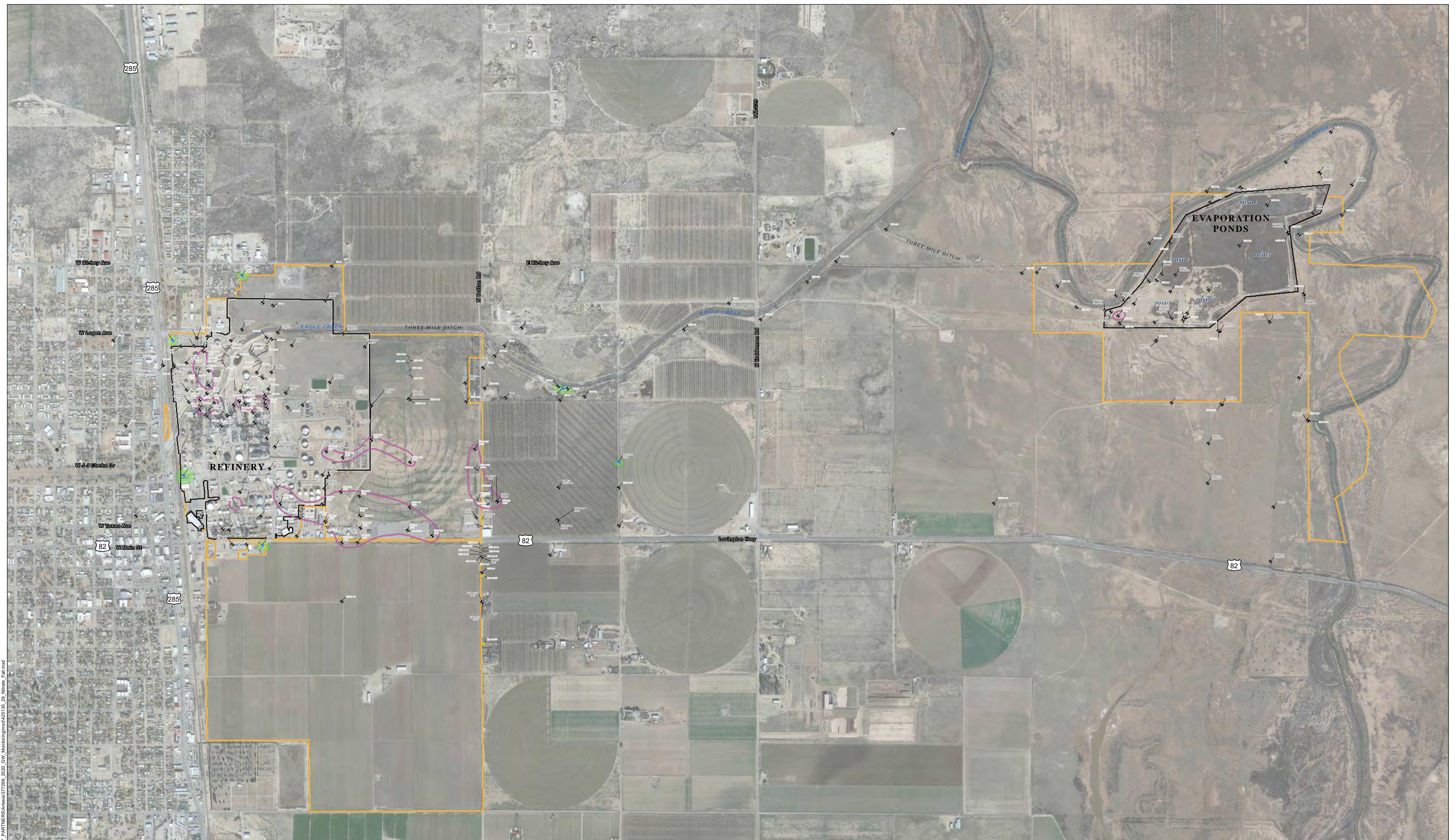

Document Path: S:\PROJECTS\HOLLY ENERGY PARTNERS\Artesia\377265_2020_GW_Monitoring\mxd\25135_29_Nitrate_Fall.mxd

AERIAL IMAGERY SOURCE: GOOGLE EARTH PRO AND THEIR DATA PARTNERS, 12/29/2019

LEGEND

- MONITORING WELL EXCEEDS SCREENING LEVELS
- MONITORING WELL
- IRRIGATION WELL
- RECOVERY WELL

NITRATE/NITRITE CONCENTRATION

- 3.99 NITRATE/NITRITE CONCENTRATION
- < 0.394 NITRATE/NITRITE NOT DETECTED ABOVE METHOD DETECTION LIMIT
- MW-103 WELL NOT SAMPLED
- PSH PHASE-SEPARATED HYDROCARBON PRESENT IN WELL (≥ 0.03 FEET THICK)
- NITRATE/NITRITE CRITICAL GROUNDWATER SCREENING LEVEL EXCEEDANCE AREA (CONCENTRATION > 10 mg/L)
- FENCELINE

HFNR PROPERTY BOUNDARY (FENCELINE SHOWN WHERE COINCIDENT)

PHASE-SEPARATED HYDROCARBON (PSH)

NOTES:

- ALL CONCENTRATIONS ARE IN MILLIGRAMS PER LITER (mg/L).
- J = CONCENTRATION QUALIFIED AS AN ESTIMATED VALUE.

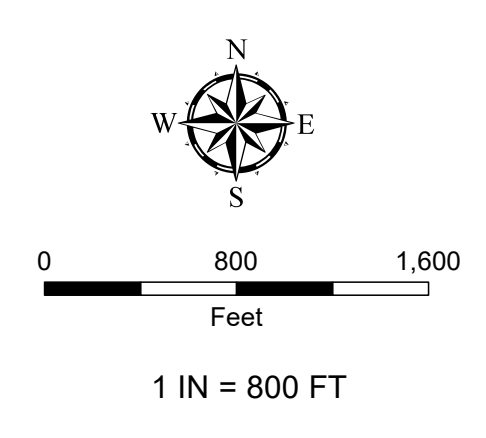

NITRATE/NITRITE CRITICAL GROUNDWATER SCREENING LEVEL EXCEEDANCE MAP 2020 SECOND SEMIANNUAL EVENT

2020 ANNUAL GROUNDWATER REPORT
 HOLLYFRONTIER NAVAJO REFINING LLC
 ARTESIA REFINERY, EDDY COUNTY, NEW MEXICO

AUTHOR: MHOHN	SAVED: 2/3/2021	MXD: 425135_29_Nitrate_Fall
---------------	-----------------	-----------------------------

TRC 505 E. HUNTLAND DR. SUITE 250 AUSTIN, TX 78752 PH:512-329-6080

FIGURE 29

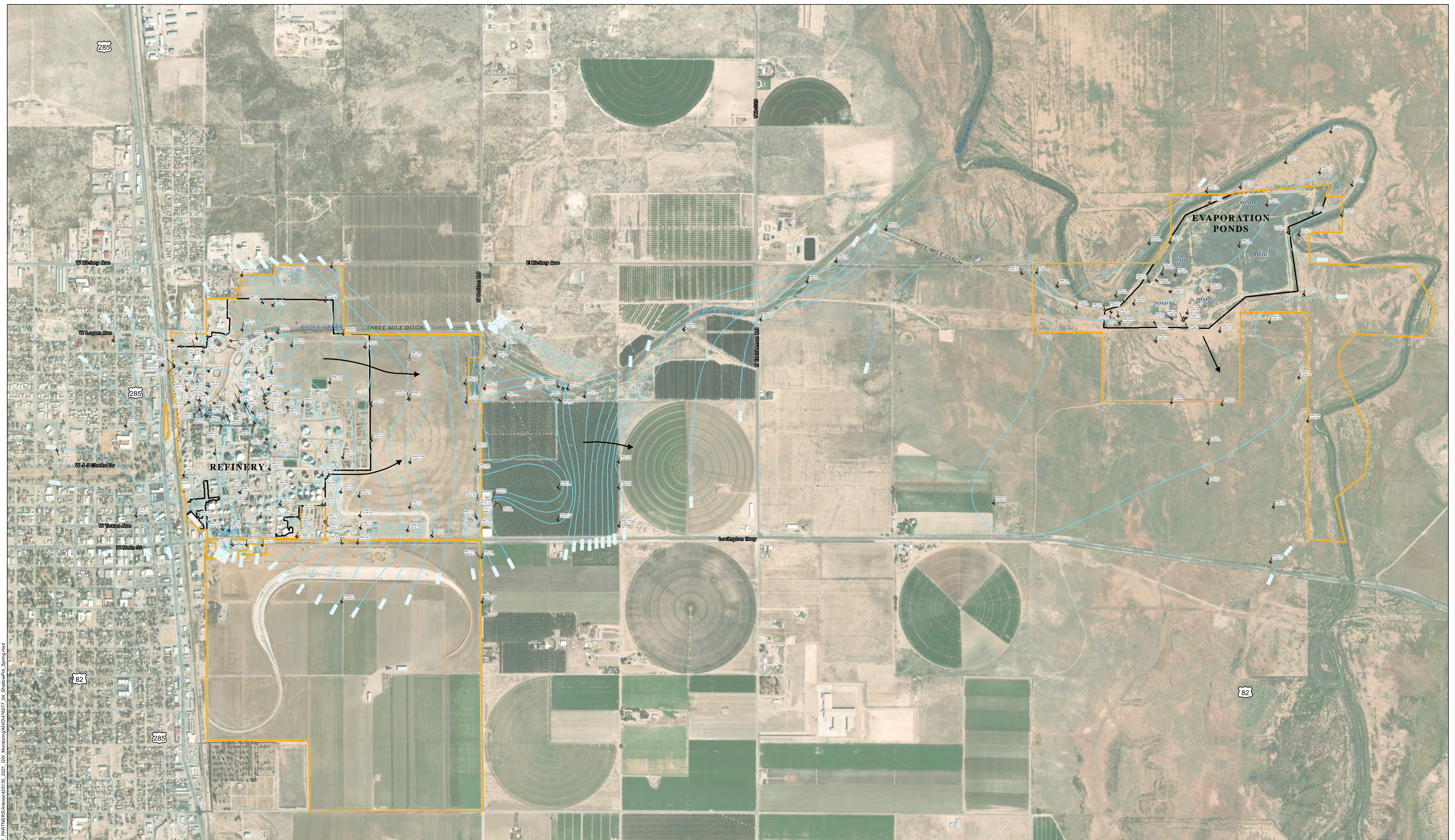

Document Path: S:\PROJECTS\HOLLY ENERGY PARTNERS\Artesia\425135_2021_GW_Monitoring\MDX476077_04_ShallowPot_Spring.mxd
 AERIAL IMAGERY SOURCE: GOOGLE EARTH PRO AND THEIR DATA PARTNERS, 3/12/2016.

LEGEND

- ◆ MONITORING WELL
- RECOVERY WELL
- GROUNDWATER FLOW DIRECTION
- SHALLOW SATURATED ZONE POTENTIOMETRIC SURFACE CONTOURS (FEET ABOVE MEAN SEA LEVEL)
- FENCELINE
- ▭ NAVAJO PROPERTY BOUNDARY (FENCELINE SHOWN WHERE COINCIDENT)
- 3335.92 GROUNDWATER ELEVATION (FEET)

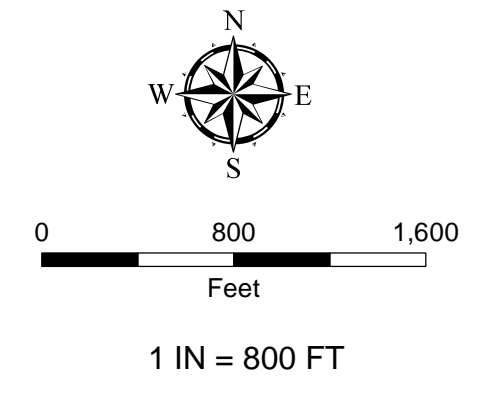

NOTE:

1. GROUNDWATER ELEVATION WAS NOT MEASURED BECAUSE WELL IS NOT IN GAUGING PROGRAM, WELL COULD NOT BE LOCATED, OR WELL WAS DAMAGED.
2. WELL WAS DRY AT TIME OF GAUGING.
3. ONLY PSH PRESENT IN THE WELL.
4. GROUNDWATER ELEVATION NOT MEASURED DUE TO PUMP IN WELL.



SHALLOW SATURATED ZONE
 POTENTIOMETRIC SURFACE MAP
 2021 FIRST SEMIANNUAL EVENT

2021 ANNUAL GROUNDWATER REPORT
 HOLLYFRONTIER NAVAJO REFINING LLC
 ARTESIA REFINERY, EDDY COUNTY, NEW MEXICO

AUTHOR: MJAGOE	SAVED: 2/2/2022	MDX: 476077_04_ShallowPot_Spring
----------------	-----------------	----------------------------------

TRC 505 E. HUNTLAND DR.
 SUITE 250
 AUSTIN, TX 78752
 PH: 512-329-6080

FIGURE
 4

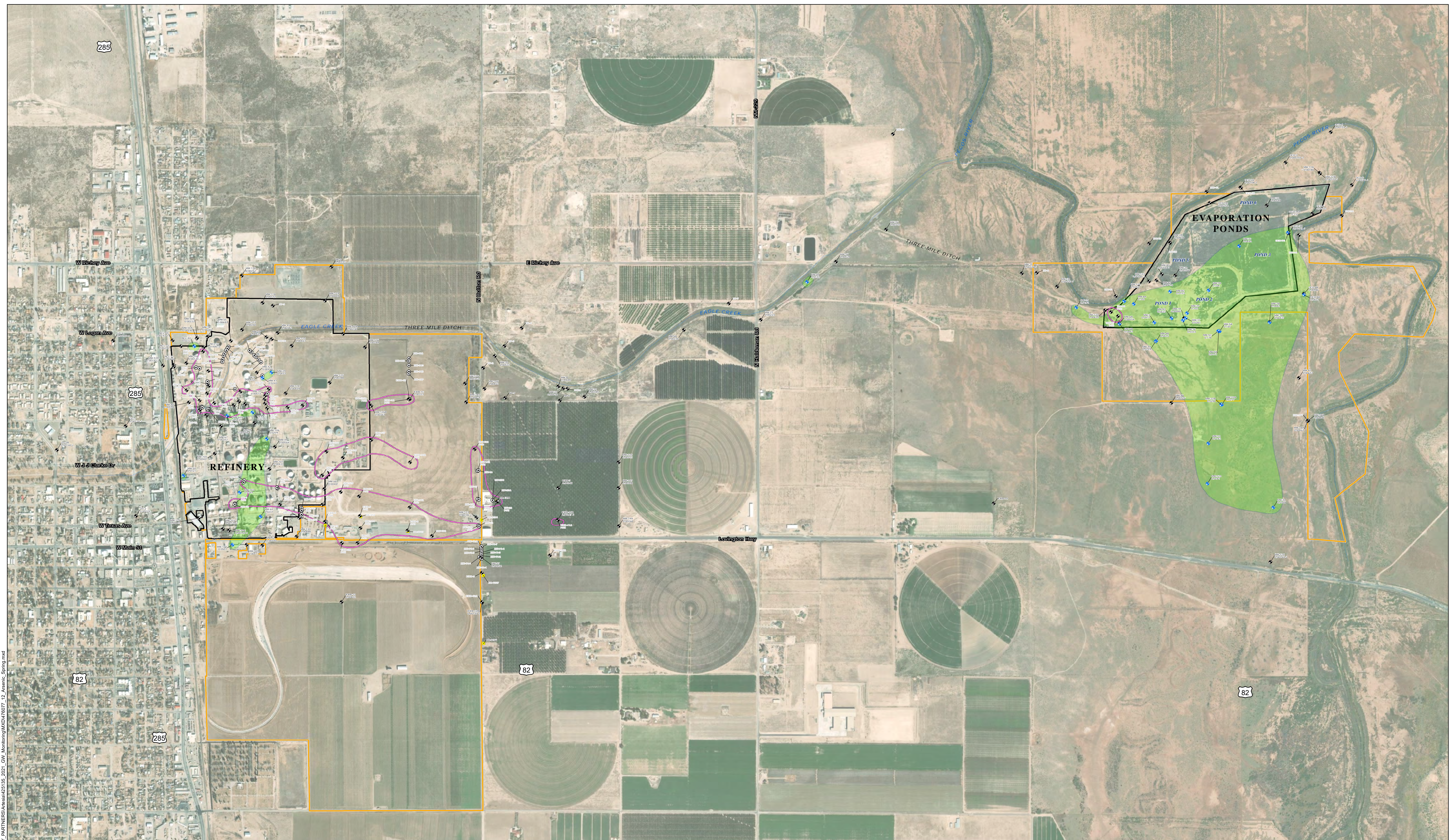

Document Path: S:\PROJECTS\HOLLY ENERGY PARTNERS\Artesia\425135_2021_GW_Monitoring\MDX\76077_12_Arsenic_Spring.mxd

AERIAL IMAGERY SOURCE: ESRI WORLD IMAGERY (101/20)

LEGEND

- ◆ MONITORING WELL EXCEEDS SCREENING LEVELS
- ◆ MONITORING WELL
- ◆ IRRIGATION WELL
- RECOVERY WELL EXCEEDS SCREENING LEVELS
- RECOVERY WELL

0.0151 ARSENIC CONCENTRATION

NAW-97 WELL NOT SAMPLED

PSH1 PHASE-SEPARATED HYDROCARBON PRESENT IN WELL (≥0.03 FEET THICK)

ARSENIC CRITICAL GROUNDWATER SCREENING LEVEL EXCEEDANCE AREA (CONCENTRATION > 0.01 mg/L)

FENCELINE

NAVAJO PROPERTY BOUNDARY (FENCELINE SHOWN WHERE COINCIDENT)

PHASE-SEPARATED HYDROCARBON (PSH)

NOTES:

1. ALL CONCENTRATIONS ARE IN MILLIGRAMS PER LITER (mg/L).
2. J = CONCENTRATION QUALIFIED AS AN ESTIMATED VALUE.

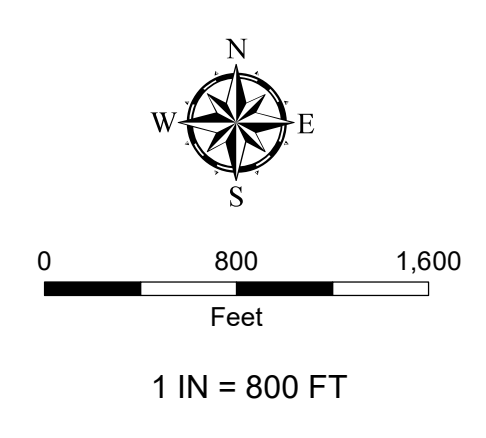

ARSENIC CRITICAL GROUNDWATER SCREENING LEVEL EXCEEDANCE MAP 2021 FIRST SEMIANNUAL EVENT

2021 ANNUAL GROUNDWATER REPORT
HOLLYFRONTIER NAVAJO REFINING, LLC
ARTESIA REFINERY, EDDY COUNTY, NEW MEXICO

AUTHOR: MJAGOE	SAVED: 2/2/2022	MDX: 476077_12_Arsenic_Spring
----------------	-----------------	-------------------------------

TRC 505 E. HUNTLAND DR. SUITE 250 AUSTIN, TX 78752 PH:512-329-6080

FIGURE 12

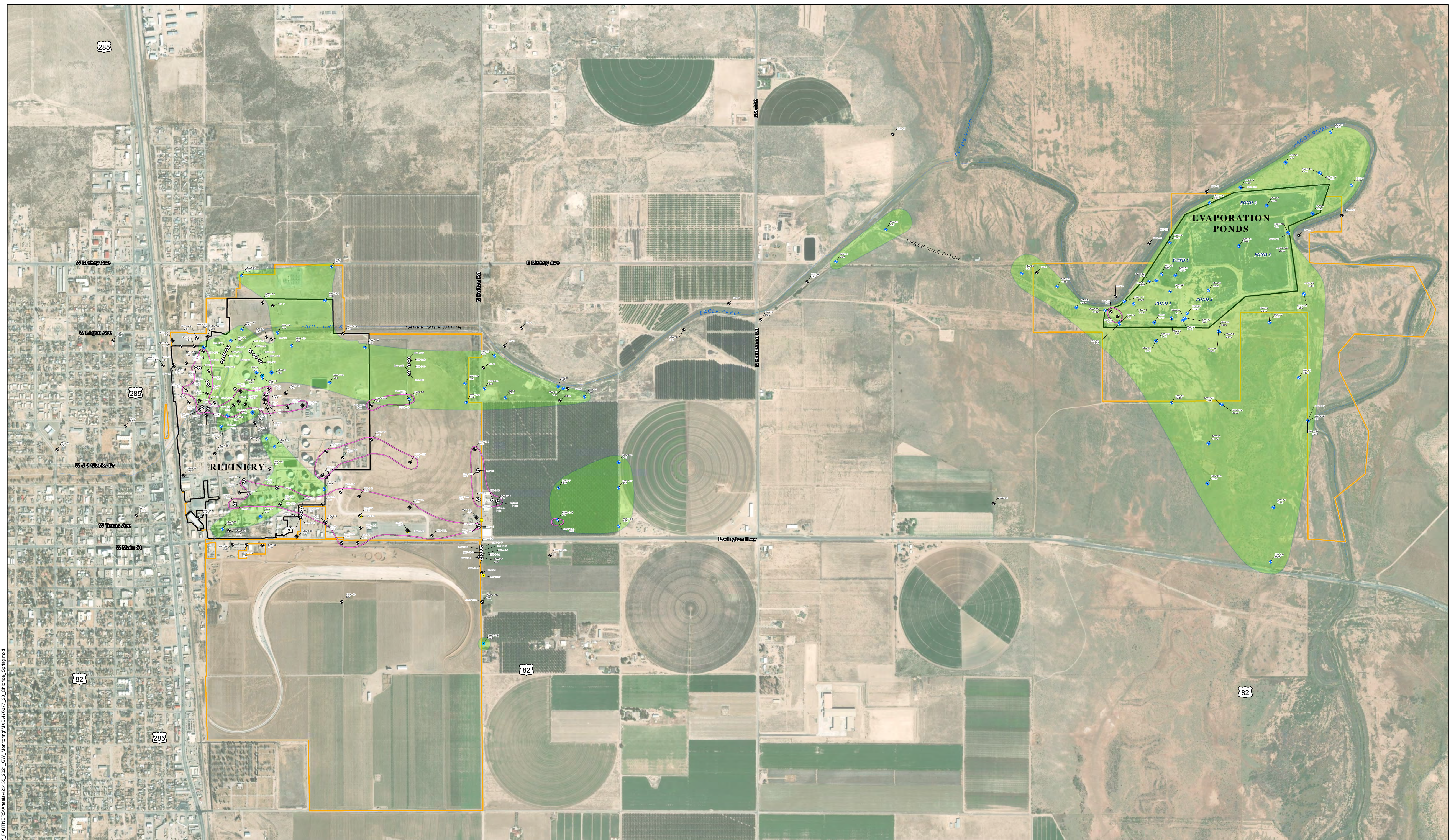

- LEGEND**
- ◆ MONITORING WELL EXCEEDS SCREENING LEVELS
 - ◆ MONITORING WELL
 - ◆ IRRIGATION WELL EXCEEDS SCREENING LEVELS
 - IRRIGATION WELL
 - RECOVERY WELL EXCEEDS SCREENING LEVELS
 - RECOVERY WELL

- 242 CHLORIDE CONCENTRATION WELL NOT SAMPLED
- PSH PHASE-SEPARATED HYDROCARBON PRESENT IN WELL (≥ 0.03 FEET THICK)
- CHLORIDE CRITICAL GROUNDWATER SCREENING LEVEL EXCEEDANCE AREA (CONCENTRATION > 250 mg/L)
- FENCELINE
- NAVAJO PROPERTY BOUNDARY (FENCELINE SHOWN WHERE COINCIDENT)

◆ PHASE-SEPARATED HYDROCARBON (PSH)

NOTES:
1. ALL CONCENTRATIONS ARE IN MILLIGRAMS PER LITER (mg/L).

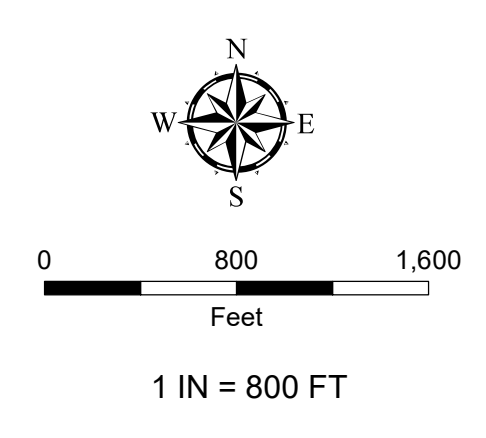

CHLORIDE CRITICAL GROUNDWATER SCREENING LEVEL EXCEEDANCE MAP 2021 FIRST SEMIANNUAL EVENT

2021 ANNUAL GROUNDWATER REPORT
HOLLYFRONTIER NAVAJO REFINING, LLC
ARTESIA REFINERY, EDDY COUNTY, NEW MEXICO

AUTHOR: MJAGOE	SAVED: 2/2/2022	MOD: 4/18/24_20_Chloride_Spring
----------------	-----------------	---------------------------------

TRC 505 E. HUNTLAND DR. SUITE 250 AUSTIN, TX 78752 PH: 512-329-6080

FIGURE 20

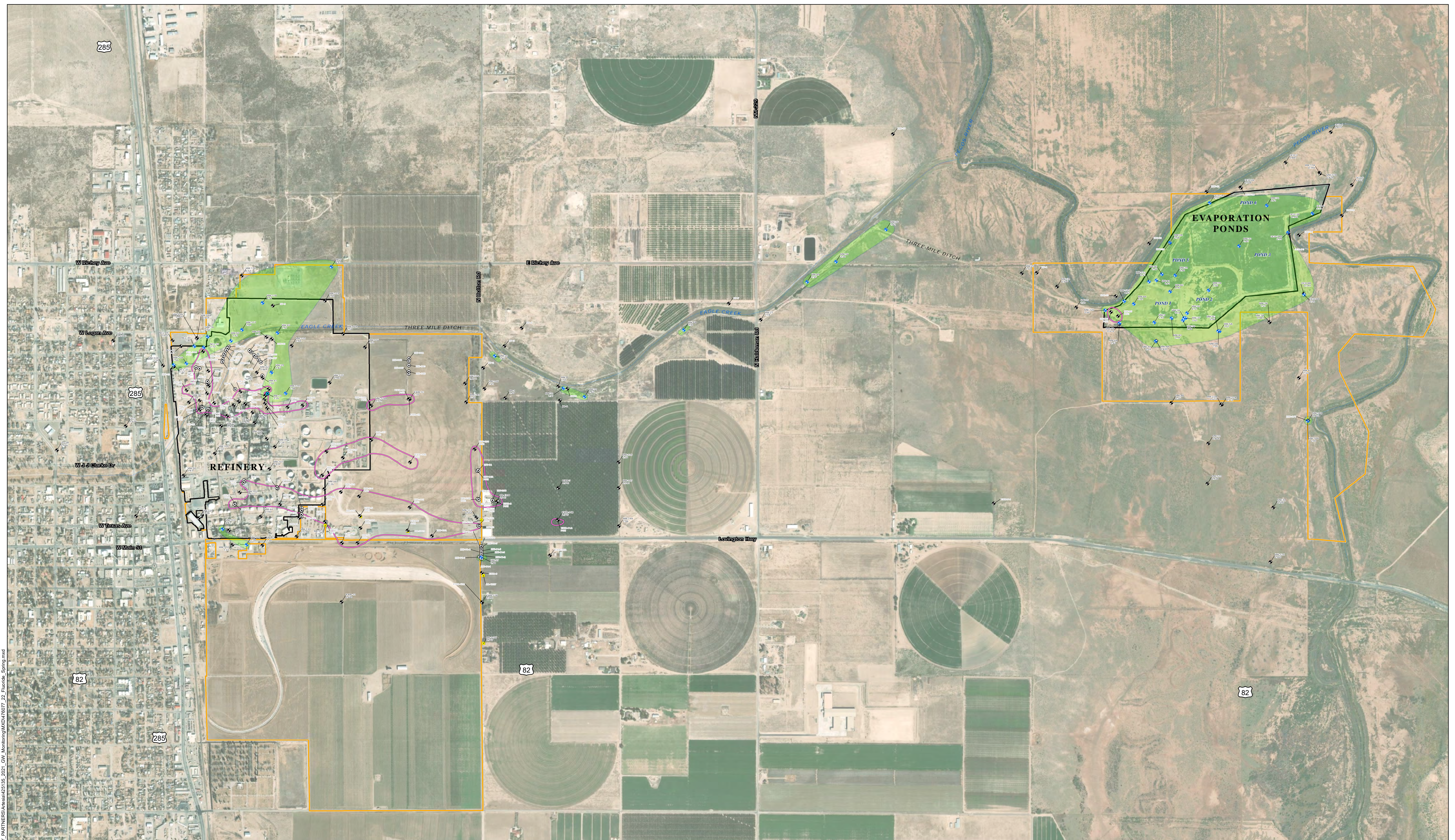

Document Path: S:\PROJECTS\HOLLY ENERGY PARTNERS\Artesia\425135_2021_GW_Monitoring\MD\767077_22_Fluoride_Spring.mxd

AERIAL IMAGERY SOURCE: ESRI WORLD IMAGERY (10/1/20)

LEGEND

	MONITORING WELL EXCEEDS SCREENING LEVELS		PHASE-SEPARATED HYDROCARBON (PSH)
	MONITORING WELL		PHASE-SEPARATED HYDROCARBON PRESENT IN WELL (≥ 0.03 FEET THICK)
	IRRIGATION WELL		FLUORIDE CRITICAL GROUNDWATER SCREENING LEVEL EXCEEDANCE AREA (CONCENTRATION > 1.6 mg/L)
	RECOVERY WELL EXCEEDS SCREENING LEVELS		FENCELINE
	RECOVERY WELL		NAVAJO PROPERTY BOUNDARY (FENCELINE SHOWN WHERE COINCIDENT)
	FLUORIDE CONCENTRATION WELL NOT SAMPLED		
	PSH		

NOTES:

1. ALL CONCENTRATIONS ARE IN MILLIGRAMS PER LITER (mg/L).

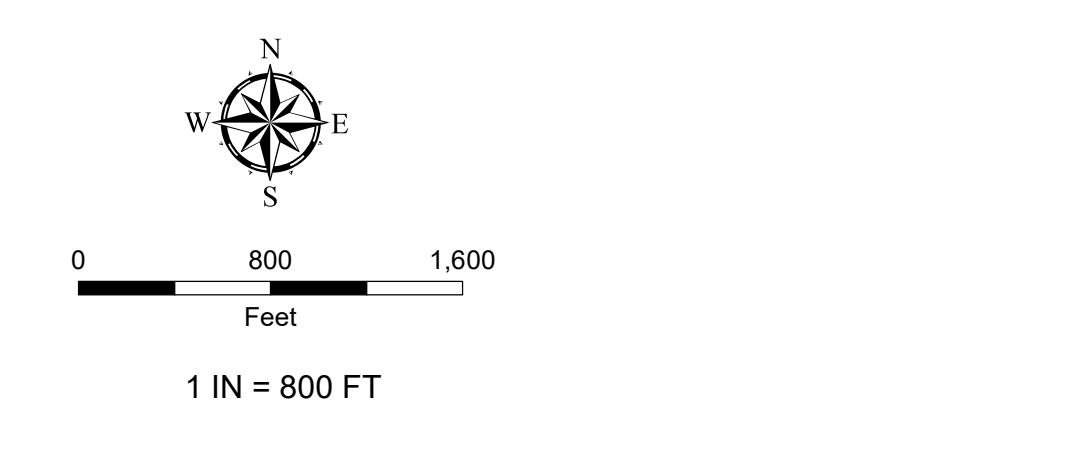
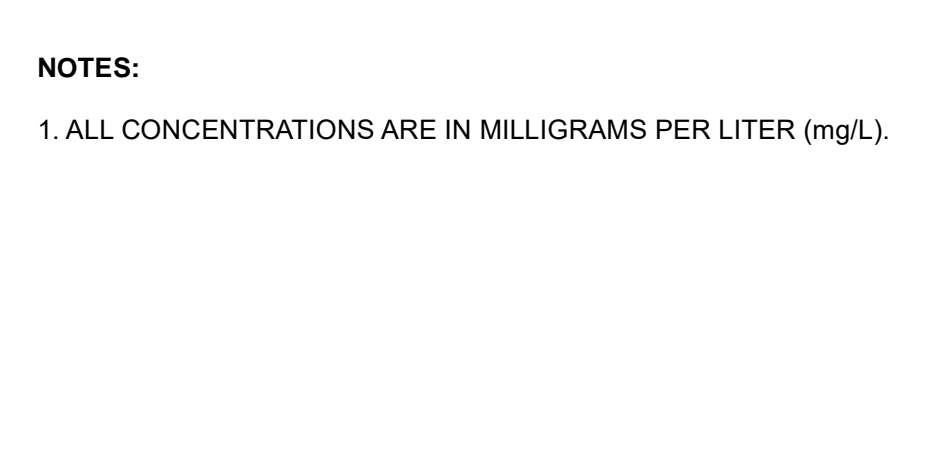

FLUORIDE CRITICAL GROUNDWATER SCREENING LEVEL EXCEEDANCE MAP 2021 FIRST SEMIANNUAL EVENT		
2021 ANNUAL GROUNDWATER REPORT HOLLYFRONTIER NAVAJO REFINING LLC ARTESIA REFINERY, EDDY COUNTY, NEW MEXICO		
AUTHOR: MJAGOE	DATED: 2/2/2022	MID: 476077_22_Fluoride_Spring
	505 E. HUNTLAND DR. SUITE 250 AUSTIN, TX 78752 PH: 512-329-6080	FIGURE 22

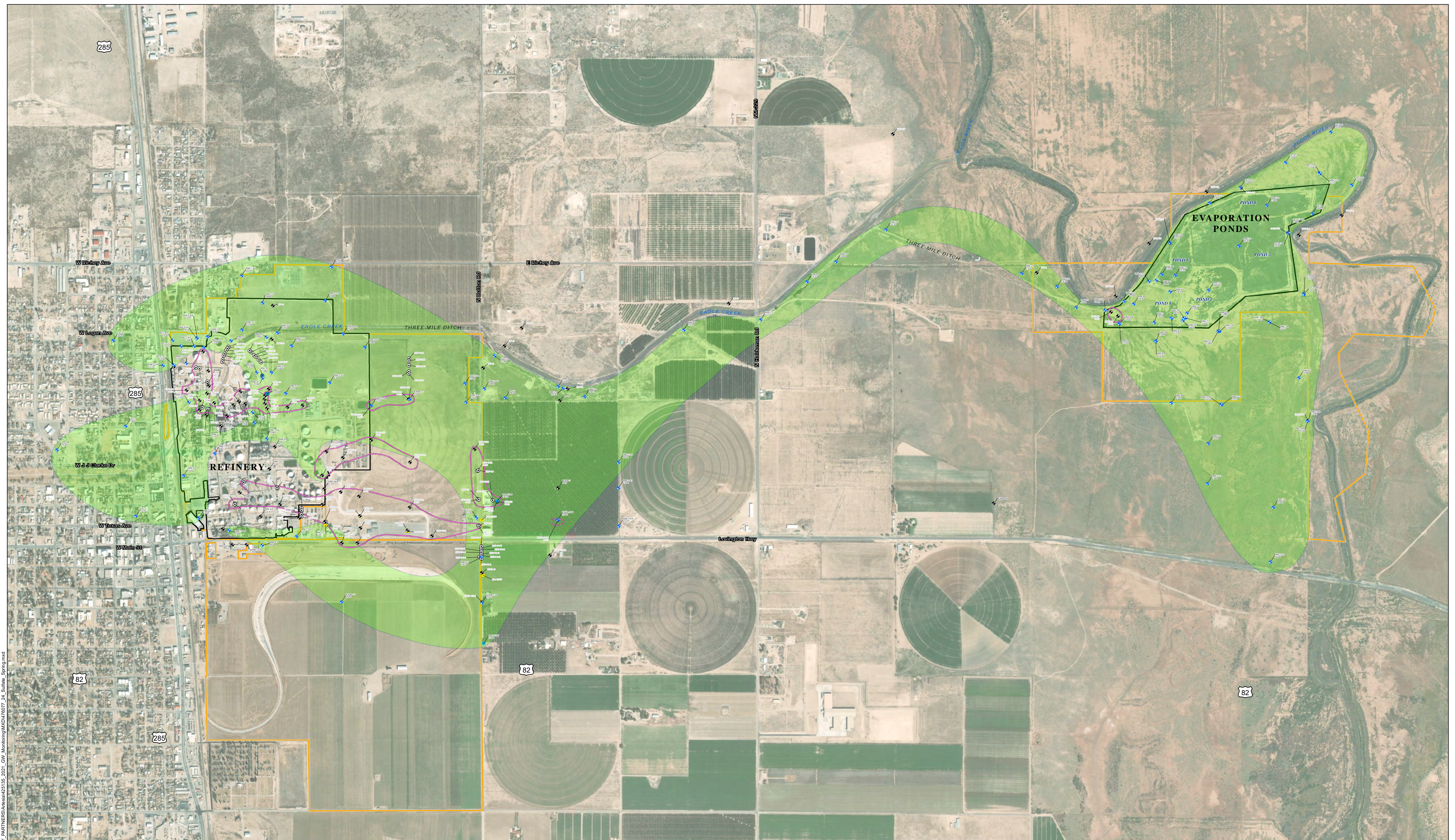

LEGEND

- ◆ MONITORING WELL EXCEEDS SCREENING LEVELS
- ◆ MONITORING WELL
- ◆ IRRIGATION WELL EXCEEDS SCREENING LEVELS
- IRRIGATION WELL
- RECOVERY WELL EXCEEDS SCREENING LEVELS
- RECOVERY WELL
- 958 Sulfate Concentration
- MW-97 Well Not Sampled
- <0.0774 Sulfate Not Detected Above Method Detection Limit
- PSH Phase-Separated Hydrocarbon Present in Well (≥ 0.03 Feet Thick)
- Sulfate Critical Groundwater Screening Level Exceedance Area (Concentration > 600 mg/L)
- FENCELINE

- NAVAJO PROPERTY BOUNDARY (FENCELINE SHOWN WHERE COINCIDENT)
- ◆ PHASE-SEPARATED HYDROCARBON (PSH)

NOTES:

1. ALL CONCENTRATIONS ARE IN MILLIGRAMS PER LITER (mg/L).
2. J = CONCENTRATION QUALIFIED AS AN ESTIMATED VALUE.

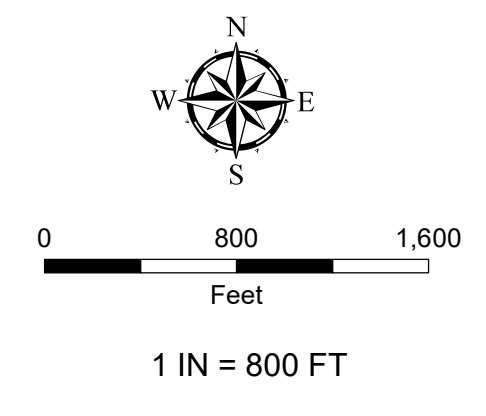

SULFATE CRITICAL GROUNDWATER SCREENING LEVEL EXCEEDANCE MAP 2021 FIRST SEMIANNUAL EVENT

2021 ANNUAL GROUNDWATER REPORT
 HOLLYFRONTIER NAVAJO REFINING, LLC
 ARTESIA REFINERY, EDDY COUNTY, NEW MEXICO

AUTHOR: MJAGOE SAVER: 1/28/2022 MOD: 4/16/24_Sulfate_Spring

	505 E. HUNTLAND DR. SUITE 250 AUSTIN, TX 78752 PH: 512-329-6080
	FIGURE 24

Document Path: S:\PROJECTS\HOLLY ENERGY PARTNERS\Artesia\425135_2021_GW_Monitoring\MXD\76077_24_Sulfate_Spring.mxd
 AERIAL IMAGERY SOURCE: ESRI WORLD IMAGERY (10120)

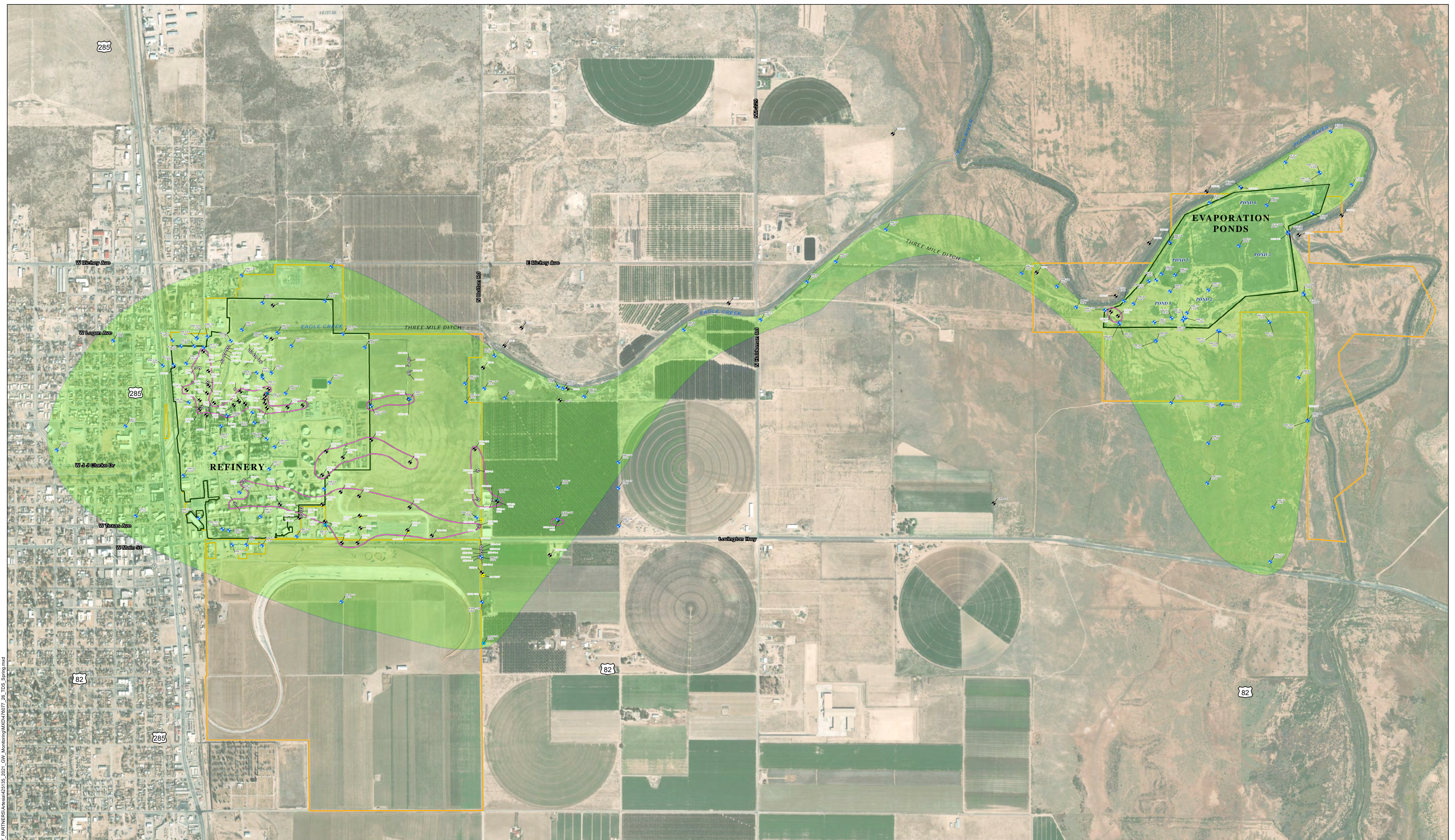

- LEGEND**
- ◆ MONITORING WELL EXCEEDS SCREENING LEVELS
 - ◆ MONITORING WELL
 - ◆ IRRIGATION WELL EXCEEDS SCREENING LEVELS
 - IRRIGATION WELL
 - RECOVERY WELL EXCEEDS SCREENING LEVELS
 - RECOVERY WELL

- 1340 TOTAL DISSOLVED SOLIDS CONCENTRATION WELL NOT SAMPLED
- PSH PHASE-SEPARATED HYDROCARBON PRESENT IN WELL (≥ 0.03 FEET THICK)
- TOTAL DISSOLVED SOLIDS CRITICAL GROUNDWATER SCREENING LEVEL EXCEEDANCE AREA (CONCENTRATION > 1000 mg/L)
- FENCELINE
- NAVAJO PROPERTY BOUNDARY (FENCELINE SHOWN WHERE COINCIDENT)

◆ PHASE-SEPARATED HYDROCARBON (PSH)

NOTES:
1. ALL CONCENTRATIONS ARE IN MILLIGRAMS PER LITER (mg/L).

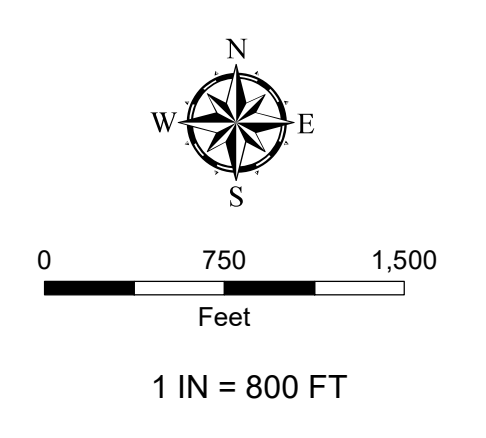

TOTAL DISSOLVED SOLIDS CRITICAL GROUNDWATER SCREENING LEVEL EXCEEDANCE MAP
2021 FIRST SEMIANNUAL EVENT
2021 ANNUAL GROUNDWATER REPORT
HOLLYFRONTIER NAVAJO REFINING LLC
ARTESIA REFINERY, EDDY COUNTY, NEW MEXICO

AUTHOR: MJAGOE SAVER: 1/28/2022 MOD: 4/16/24_26_TDS_Spring

505 E. HUNTLAND DR.
SUITE 250
AUSTIN, TX 78752
PH: 512-329-6080

FIGURE 26

Document Path: S:\PROJECTS\HOLLY ENERGY PARTNERS\Artesia\425135_2021_GW_Monitoring\WDR\7677_26_TDS_Spring.mxd

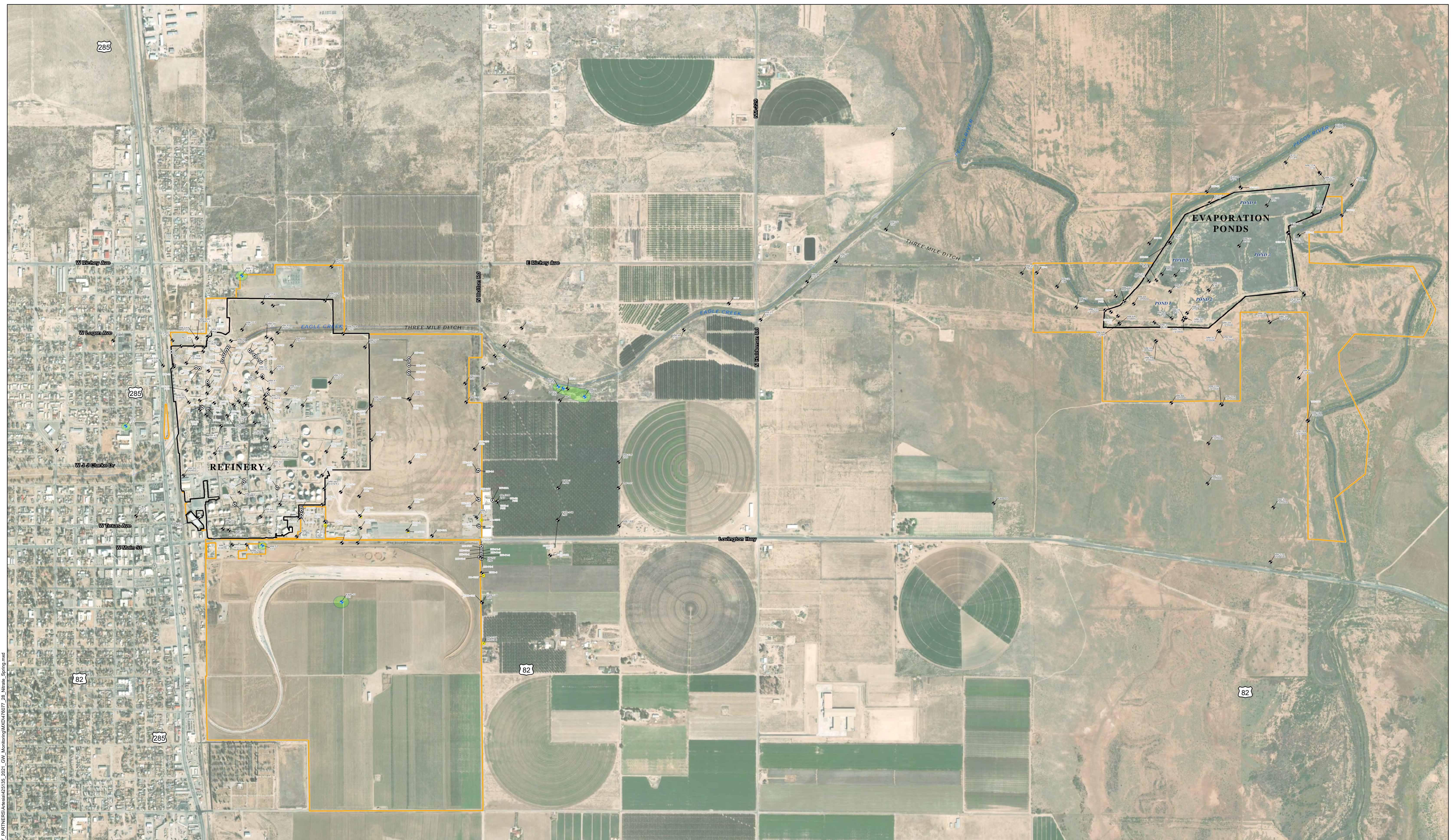

- LEGEND**
- ◆ MONITORING WELL EXCEEDS SCREENING LEVELS
 - ◆ MONITORING WELL
 - IRRIGATION WELL
 - RECOVERY WELL

- 11.00 NITRATE/NITRITE CONCENTRATION
- < 0.197 NITRATE/NITRITE NOT DETECTED ABOVE METHOD DETECTION LIMIT
- MAV-19 WELL NOT SAMPLED
- PSH PHASE-SEPARATED HYDROCARBON PRESENT IN WELL (≥ 0.03 FEET THICK)
- NITRATE/NITRITE CRITICAL GROUNDWATER SCREENING LEVEL EXCEEDANCE AREA (CONCENTRATION > 10 mg/L)
- FENCELINE

- NAVAJO PROPERTY BOUNDARY (FENCELINE SHOWN WHERE COINCIDENT)
- PHASE-SEPARATED HYDROCARBON (PSH)

NOTES:

1. ALL CONCENTRATIONS ARE IN MILLIGRAMS PER LITER (mg/L).
2. J = CONCENTRATION QUALIFIED AS AN ESTIMATED VALUE.

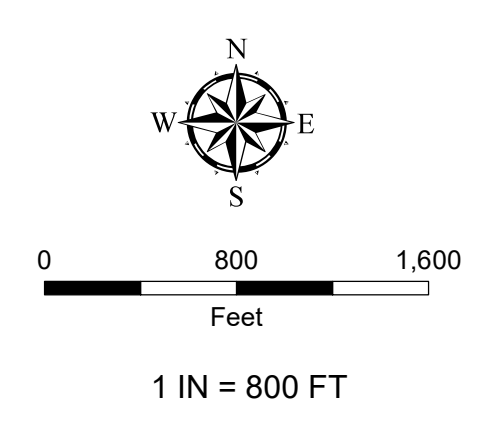

NITRATE/NITRITE CRITICAL GROUNDWATER SCREENING LEVEL EXCEEDANCE MAP 2021 FIRST SEMIANNUAL EVENT

2021 ANNUAL GROUNDWATER REPORT
HOLLYFRONTIER NAVAJO REFINING LLC
ARTESIA REFINERY, EDDY COUNTY, NEW MEXICO

AUTHOR: MJAGOE	SAVED: 2/2/2022	MXD: 4/16/2022_Nitrate_Spring
----------------	-----------------	-------------------------------

TRC 505 E. HUNTLAND DR. SUITE 250 AUSTIN, TX 78752 PH:512-329-6080

FIGURE 28

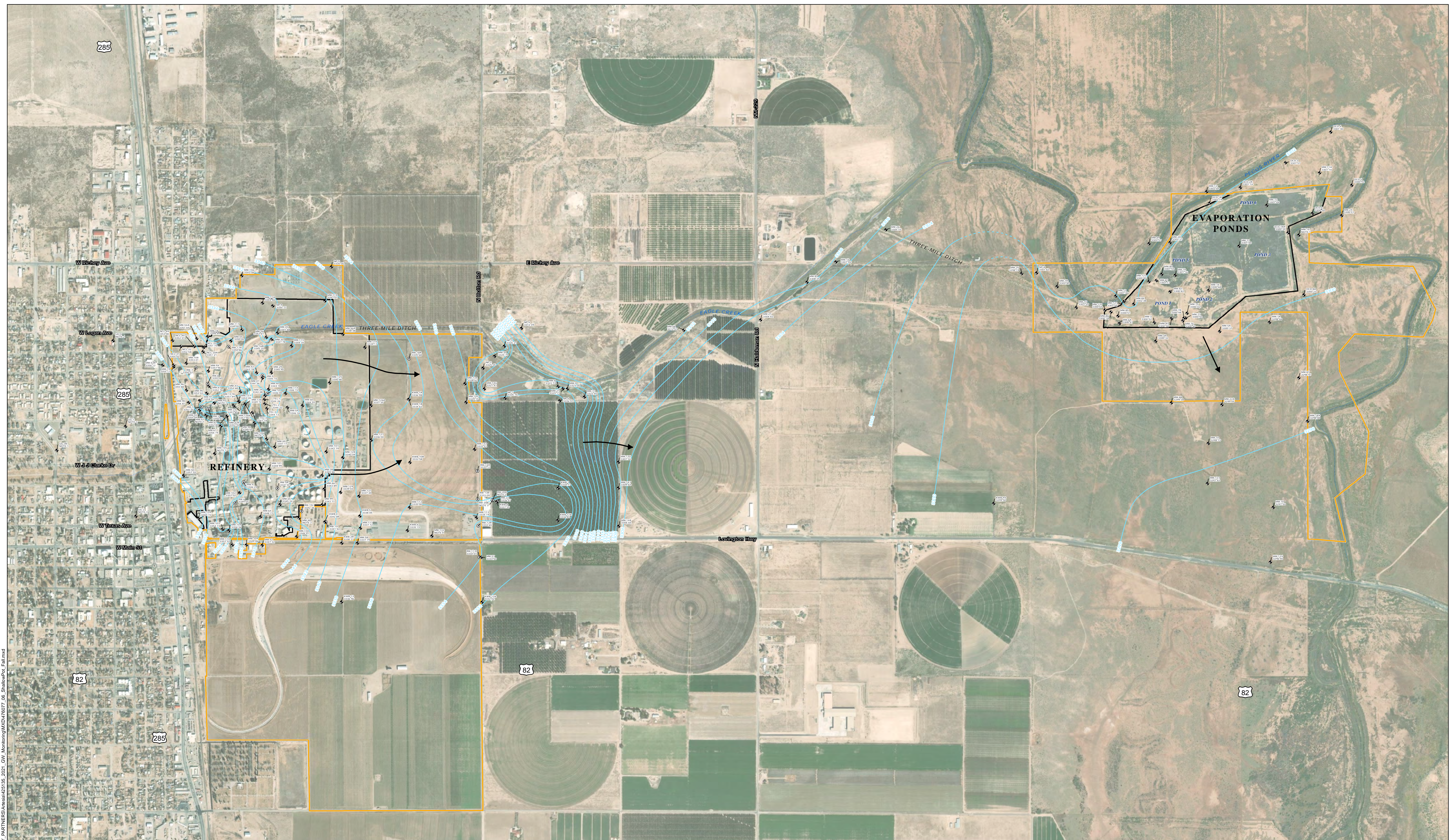

Document Path: S:\PROJECTS\HOLLY ENERGY PARTNERS\Artesia\425135_2021_GW_Monitoring\MXD\7677_06_ShallowPot_Fall.mxd
 AERIAL IMAGERY SOURCE: ESRI WORLD IMAGERY (101/20)

LEGEND

- ◆ MONITORING WELL
- RECOVERY WELL
- GROUNDWATER FLOW DIRECTION
- SHALLOW SATURATED ZONE POTENTIOMETRIC SURFACE CONTOURS - DASHED WHERE INFERRED (FEET ABOVE MEAN SEA LEVEL)
- FENCELINE
- ▭ NAVAJO PROPERTY BOUNDARY (FENCELINE SHOWN WHERE COINCIDENT)
- 3349.57 GROUNDWATER ELEVATION (FEET)

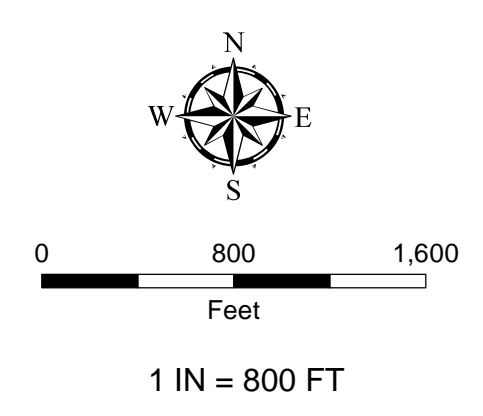

NOTE:

1. GROUNDWATER ELEVATION WAS NOT MEASURED BECAUSE WELL IS NOT IN GAUGING PROGRAM, WELL COULD NOT BE LOCATED, OR WELL WAS DAMAGED.
2. WELL WAS DRY AT TIME OF GAUGING.
3. GROUNDWATER ELEVATION NOT USED IN POTENTIOMETRIC SURFACE CONTOURING.
4. GROUNDWATER ELEVATION NOT MEASURED DUE TO PUMP IN WELL.



SHALLOW SATURATED ZONE
 POTENTIOMETRIC SURFACE MAP
 2021 SECOND SEMIANNUAL EVENT

2021 ANNUAL GROUNDWATER REPORT
 HOLLYFRONTIER NAVAJO REFINING, LLC
 ARTESIA REFINERY, EDDY COUNTY, NEW MEXICO

AUTHOR: MJAGOE	SAVED: 2/2/2022	MXD: 476277_06_ShallowPot_Fall
----------------	-----------------	--------------------------------

TRC 505 E. HUNTLAND DR. SUITE 250 AUSTIN, TX 78752 PH:512-329-6080

FIGURE 6

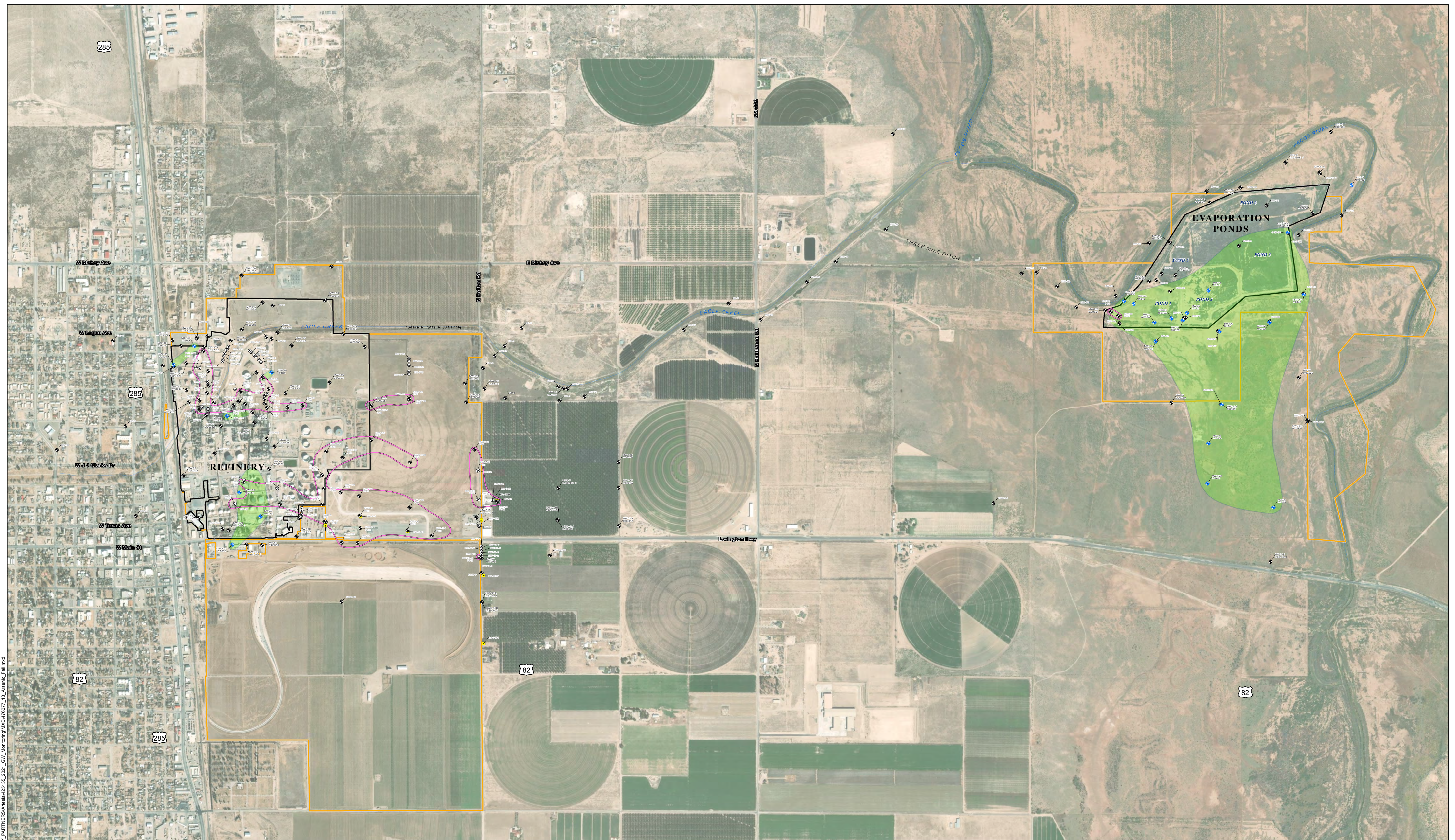

Document Path: S:\PROJECTS\HOLLY ENERGY PARTNERS\Artesia\425135_2021_GW_Monitoring\MXD\76077_13_Arsenic_Fall.mxd

AERIAL IMAGERY SOURCE: ESRI WORLD IMAGERY (101/20)

LEGEND

- ◆ MONITORING WELL EXCEEDS SCREENING LEVELS
- ♦ MONITORING WELL
- IRRIGATION WELL
- RECOVERY WELL
- 00144 ARSENIC CONCENTRATION
- 1MW-105 WELL NOT SAMPLED
- PSH PHASE-SEPARATED HYDROCARBON PRESENT IN WELL (≥ 0.03 FEET THICK)
- ARSENIC CRITICAL GROUNDWATER SCREENING LEVEL EXCEEDANCE AREA (CONCENTRATION > 0.01 mg/L)
- FENCELINE

- NAVAJO PROPERTY BOUNDARY (FENCELINE SHOWN WHERE COINCIDENT)
- PHASE-SEPARATED HYDROCARBON (PSH)

NOTES:

- ALL CONCENTRATIONS ARE IN MILLIGRAMS PER LITER (mg/L).
- J = CONCENTRATION QUALIFIED AS AN ESTIMATED VALUE.

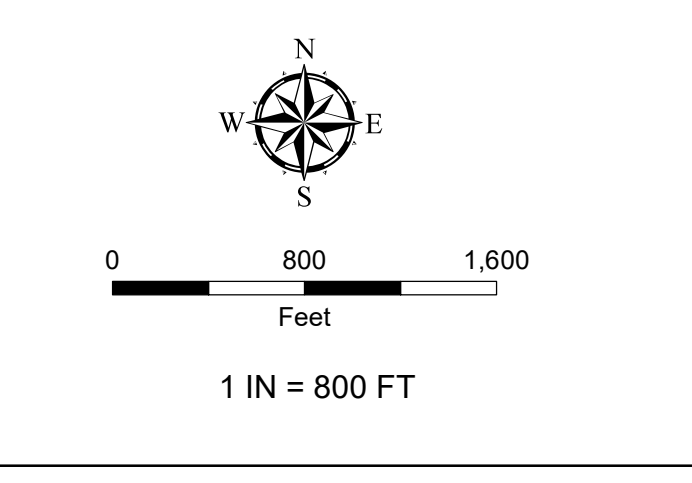

ARSENIC CRITICAL GROUNDWATER SCREENING LEVEL EXCEEDANCE MAP 2021 SECOND SEMIANNUAL EVENT

2021 ANNUAL GROUNDWATER REPORT
 HOLLYFRONTIER NAVAJO REFINING, LLC
 ARTESIA REFINERY, EDDY COUNTY, NEW MEXICO

AUTHOR: MJAGOE	SAVED: 1/28/2022	MOD: 4/16/2024_13_Arsenic_Fall
----------------	------------------	--------------------------------

TRC 505 E. HUNTLAND DR. SUITE 250 AUSTIN, TX 78752 PH: 512-329-6080

FIGURE 13

District I
 1625 N. French Dr., Hobbs, NM 88240
 Phone:(575) 393-6161 Fax:(575) 393-0720

District II
 811 S. First St., Artesia, NM 88210
 Phone:(575) 748-1283 Fax:(575) 748-9720

District III
 1000 Rio Brazos Rd., Aztec, NM 87410
 Phone:(505) 334-6178 Fax:(505) 334-6170

District IV
 1220 S. St Francis Dr., Santa Fe, NM 87505
 Phone:(505) 476-3470 Fax:(505) 476-3462

State of New Mexico
Energy, Minerals and Natural Resources
Oil Conservation Division
1220 S. St Francis Dr.
Santa Fe, NM 87505

CONDITIONS

Action 335117

CONDITIONS

Operator: HF Sinclair Navajo Refining LLC ATTN: GENERAL COUNSEL Dallas, TX 75201	OGRID: 15694
	Action Number: 335117
	Action Type: [UF-GWA] Ground Water Abatement (GROUND WATER ABATEMENT)

CONDITIONS

Created By	Condition	Condition Date
michael.buchanan	RO Stage 2 Abatement Plan Rev 04182024Part-1.pdf has been received for the record, Appendix C, D and E not included. Remaining appendices submitted as a separate files.	5/8/2024