

Office
District I - (575) 393-6161
1625 N. French Dr., Hobbs, NM 88240
District II - (575) 748-1283
811 S. First St., Artesia, NM 88210
District III - (505) 334-6178
1000 Rio Brazos Rd., Aztec, NM 87410
District IV - (505) 476-3460
1220 S. St. Francis Dr., Santa Fe, NM 87505

State of New Mexico
Energy, Minerals and Natural Resources

Form C-103
Revised July 18, 2013

OIL CONSERVATION DIVISION
1220 South St. Francis Dr.
Santa Fe, NM 87505

WELL API NO.
5. Indicate Type of Lease
STATE [] FEE []
6. State Oil & Gas Lease No.
7. Lease Name or Unit Agreement Name
8. Well Number
9. OGRID Number
10. Pool name or Wildcat

SUNDRY NOTICES AND REPORTS ON WELLS
(DO NOT USE THIS FORM FOR PROPOSALS TO DRILL OR TO DEEPEN OR PLUG BACK TO A DIFFERENT RESERVOIR. USE "APPLICATION FOR PERMIT" (FORM C-101) FOR SUCH PROPOSALS.)
1. Type of Well: Oil Well [] Gas Well [] Other []
2. Name of Operator
3. Address of Operator

4. Well Location
Unit Letter _____ : _____ feet from the _____ line and _____ feet from the _____ line
Section _____ Township _____ Range _____ NMPM _____ County _____
11. Elevation (Show whether DR, RKB, RT, GR, etc.)

12. Check Appropriate Box to Indicate Nature of Notice, Report or Other Data

NOTICE OF INTENTION TO:
PERFORM REMEDIAL WORK [] PLUG AND ABANDON []
TEMPORARILY ABANDON [] CHANGE PLANS []
PULL OR ALTER CASING [] MULTIPLE COMPL []
DOWNHOLE COMMINGLE []
CLOSED-LOOP SYSTEM []
OTHER: []
SUBSEQUENT REPORT OF:
REMEDIAL WORK [] ALTERING CASING []
COMMENCE DRILLING OPNS. [] P AND A []
CASING/CEMENT JOB []
OTHER: []

13. Describe proposed or completed operations. (Clearly state all pertinent details, and give pertinent dates, including estimated date of starting any proposed work). SEE RULE 19.15.7.14 NMAC. For Multiple Completions: Attach wellbore diagram of proposed completion or recompletion.

Condition of Approval: notify
OCD Hobbs office 24 hours
prior of running MIT Test & Chart

Spud Date: []

Rig Release Date: []

I hereby certify that the information above is true and complete to the best of my knowledge and belief.

SIGNATURE alicia fulton TITLE DATE

Type or print name E-mail address: PHONE:

For State Use Only

APPROVED BY: Kerry Fortner TITLE Compliance Officer A DATE 3/9/23
Conditions of Approval

Current WBD

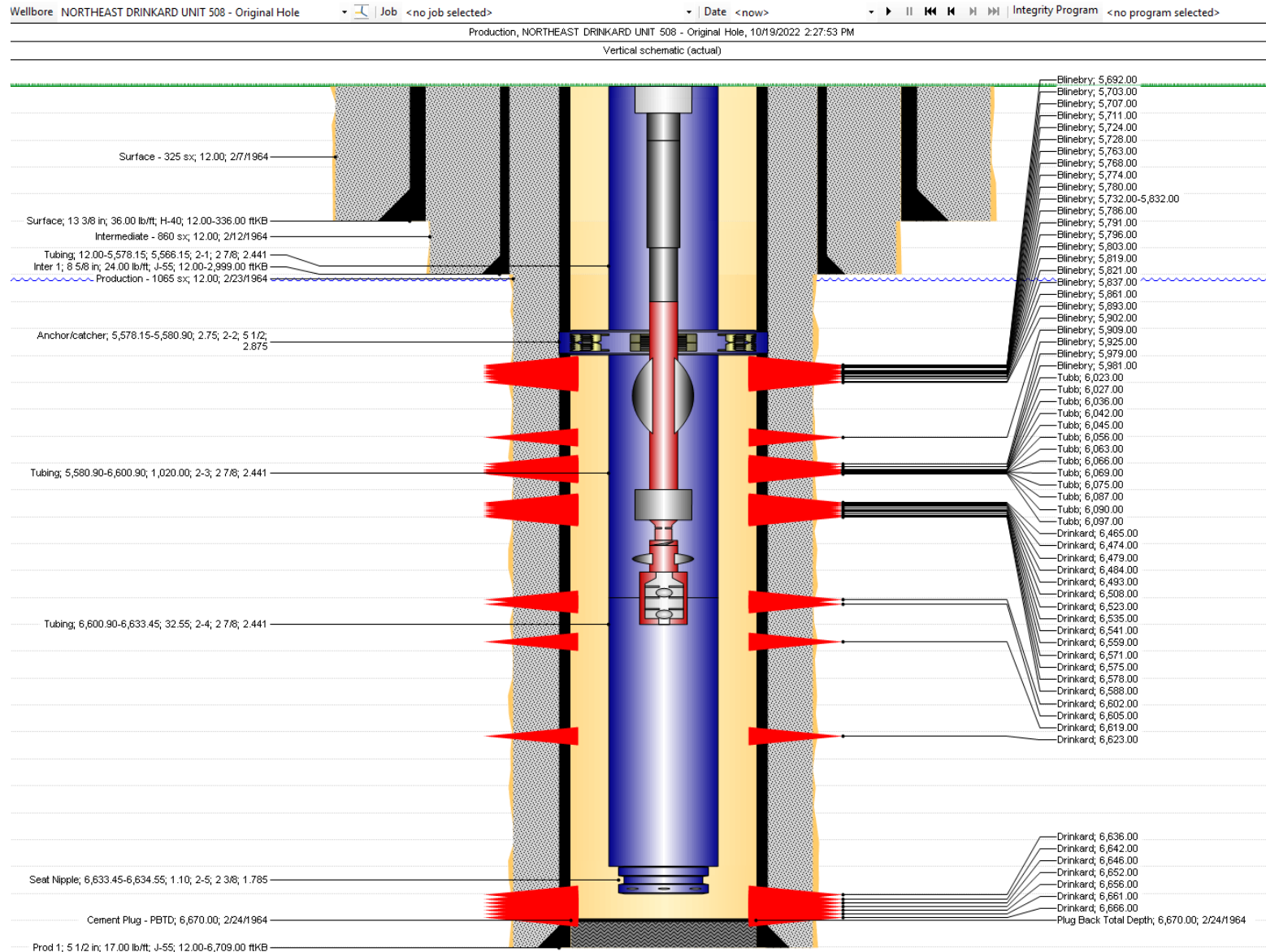

proposed WBD

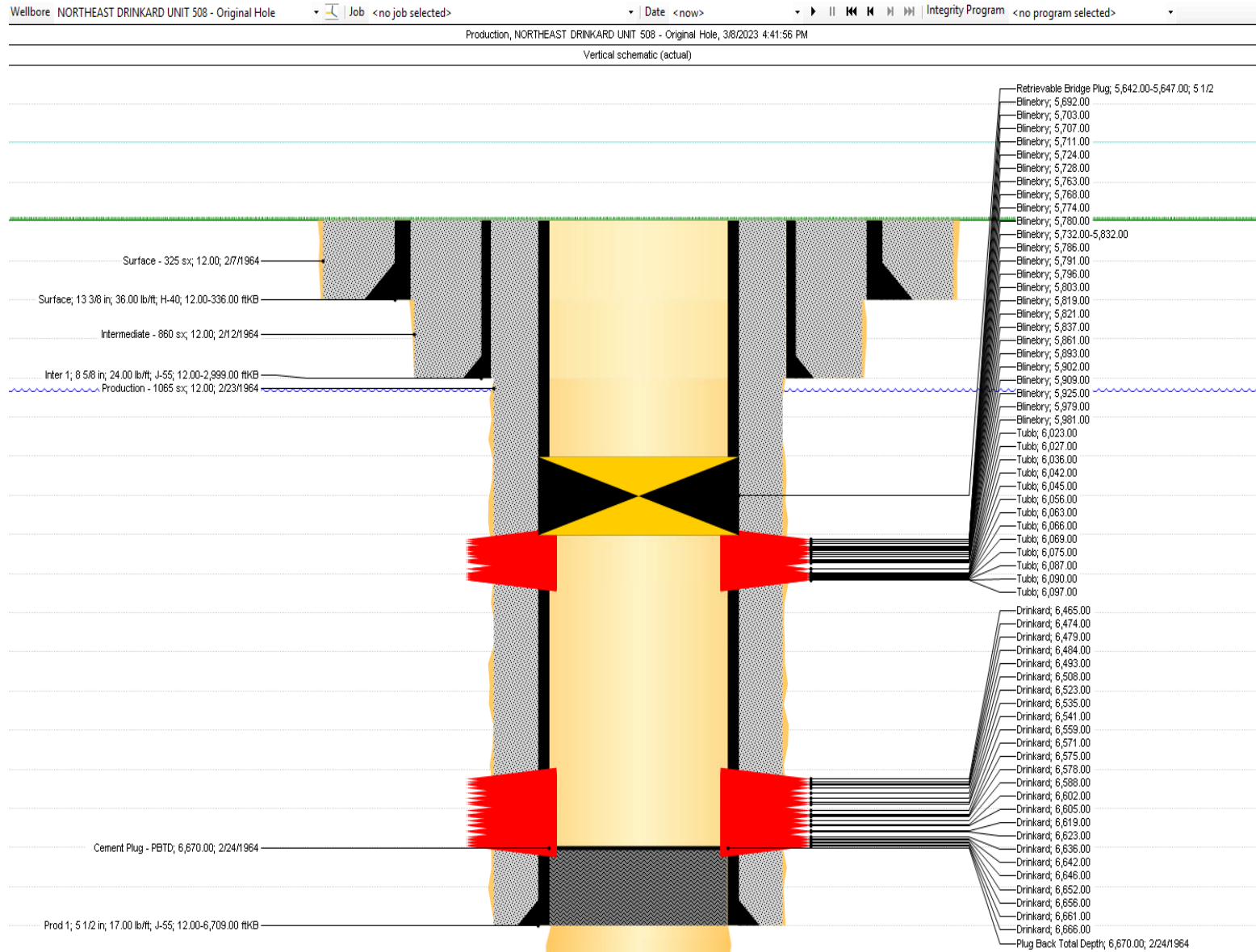

District I
 1625 N. French Dr., Hobbs, NM 88240
 Phone:(575) 393-6161 Fax:(575) 393-0720

District II
 811 S. First St., Artesia, NM 88210
 Phone:(575) 748-1283 Fax:(575) 748-9720

District III
 1000 Rio Brazos Rd., Aztec, NM 87410
 Phone:(505) 334-6178 Fax:(505) 334-6170

District IV
 1220 S. St Francis Dr., Santa Fe, NM 87505
 Phone:(505) 476-3470 Fax:(505) 476-3462

State of New Mexico
Energy, Minerals and Natural Resources
Oil Conservation Division
1220 S. St Francis Dr.
Santa Fe, NM 87505

CONDITIONS

Action 195483

CONDITIONS

Operator: APACHE CORPORATION 303 Veterans Airpark Ln Midland, TX 79705	OGRID: 873
	Action Number: 195483
	Action Type: [C-103] NOI Workover (C-103G)

CONDITIONS

Created By	Condition	Condition Date
kfortner	Run PWOT	3/9/2023