



U.S. Department of the Interior
Bureau of Land Management

Application for Permit to Drill

APD Package Report

Date Printed: 01/26/2026 02:36 PM

APD ID: 10400108077

Well Status: AAPD

APD Received Date: 10/30/2025 01:24 PM

Well Name: KOALA 9 FED COM

Operator: PERMIAN RESOURCES OPERATING Well Number: 124H

APD Package Report Contents

- Form 3160-3
- Operator Certification Report
- Application Report
- Application Attachments
 - Well Plat: 1 file(s)
- Drilling Plan Report
- Drilling Plan Attachments
 - Blowout Prevention Choke Diagram Attachment: 1 file(s)
 - Blowout Prevention BOP Diagram Attachment: 1 file(s)
 - Casing Spec Documents: 1 file(s)
 - Casing Design Assumptions and Worksheet(s): 3 file(s)
 - Hydrogen sulfide drilling operations plan: 2 file(s)
 - Proposed horizontal/directional/multi-lateral plan submission: 2 file(s)
 - Other Facets: 1 file(s)
 - Other Variances: 5 file(s)
- SUPO Report
- SUPO Attachments
 - Existing Road Map: 1 file(s)
 - Attach Well map: 1 file(s)
 - Production Facilities map: 2 file(s)
 - Water source and transportation map: 1 file(s)
 - Construction Materials source location attachment: 1 file(s)
 - Well Site Layout Diagram: 2 file(s)
 - Recontouring attachment: 2 file(s)
 - Other SUPO Attachment: 2 file(s)
- PWD Report
- PWD Attachments
 - None

- Bond Report
- Bond Attachments
 - None

Form 3160-3
(October 2024)

FORM APPROVED
OMB No. 1004-0220
Expires: October 31, 2027

UNITED STATES
DEPARTMENT OF THE INTERIOR
BUREAU OF LAND MANAGEMENT
APPLICATION FOR PERMIT TO DRILL OR REENTER

1a. Type of work: <input checked="" type="checkbox"/> DRILL <input type="checkbox"/> REENTER 1b. Type of Well: <input type="checkbox"/> Oil Well <input checked="" type="checkbox"/> Gas Well <input type="checkbox"/> Other 1c. Type of Completion: <input type="checkbox"/> Hydraulic Fracturing <input checked="" type="checkbox"/> Single Zone <input type="checkbox"/> Multiple Zone		5. Lease Serial No. NMNM15003
2. Name of Operator PERMIAN RESOURCES OPERATING LLC		6. If Indian, Allottee or Tribe Name 7. If Unit or CA Agreement, Name and No. 8. Lease Name and Well No. KOALA 9 FED COM 124H
3a. Address 300 N MARIENFELD ST SUITE 1000, MIDLAND, TX 79701	3b. Phone No. (include area code) (432) 695-4222	9. API Well No. 30-015-57790
4. Location of Well (Report location clearly and in accordance with any State requirements. *) At surface SESE / 1144 FSL / 165 FEL / LAT 32.58397 / LONG -104.19173 At proposed prod. zone SESE / 330 FSL / 10 FEL / LAT 32.58188 / LONG -104.15668		10. Field and Pool, or Exploratory BURTON FLAT/MORROW (PRO GAS) 11. Sec., T. R. M. or Blk. and Survey or Area SEC 8/T20S/R28E/NMP
14. Distance in miles and direction from nearest town or post office*		12. County or Parish EDDY
13. State NM		
15. Distance from proposed* location to nearest property or lease line, ft. (Also to nearest drig. unit line, if any) 165 feet	16. No of acres in lease	17. Spacing Unit dedicated to this well 320.0
18. Distance from proposed location* to nearest well, drilling, completed, applied for, on this lease, ft. 30 feet	19. Proposed Depth 7329 feet / 17819 feet	20. BLM/BIA Bond No. in file FED: NMB001841
21. Elevations (Show whether DF, KDB, RT, GL., etc.) 3274 feet	22. Approximate date work will start* 04/27/2026	23. Estimated duration 45 days
24. Attachments		

The following, completed in accordance with the requirements of Onshore Oil and Gas Order No. 1, and the Hydraulic Fracturing rule per 43 CFR 3162.3-3 (as applicable)

- | | |
|---|---|
| 1. Well plat certified by a registered surveyor.
2. A Drilling Plan.
3. A Surface Use Plan (if the location is on National Forest System Lands, the SUPO must be filed with the appropriate Forest Service Office). | 4. Bond to cover the operations unless covered by an existing bond on file (see Item 20 above).
5. Operator certification.
6. Such other site specific information and/or plans as may be requested by the BLM. |
|---|---|

25. Signature (Electronic Submission)	Name (Printed/Typed) CASSIE EVANS / Ph: (432) 695-4222	Date 10/30/2025
Title Regulatory Specialist		
Approved by (Signature) (Electronic Submission)	Name (Printed/Typed) CHRISTOPHER WALLS / Ph: (575) 234-2234	Date 01/26/2026
Title Petroleum Engineer		
Office Carlsbad Field Office		

Application approval does not warrant or certify that the applicant holds legal or equitable title to those rights in the subject lease which would entitle the applicant to conduct operations thereon.
 Conditions of approval, if any, are attached.

Title 18 U.S.C. Section 1001 and Title 43 U.S.C. Section 1212, make it a crime for any person knowingly and willfully to make to any department or agency of the United States any false, fictitious or fraudulent statements or representations as to any matter within its jurisdiction.



(Continued on page 2)

*(Instructions on page 2)

INSTRUCTIONS

GENERAL: This form is designed for submitting proposals to perform certain well operations, as indicated on Federal and Indian lands and leases for action by appropriate Federal agencies, pursuant to applicable Federal laws and regulations. Any necessary special instructions concerning the use of this form and the number of copies to be submitted, particularly with regard to local, area, or regional procedures and practices, either are shown below or will be issued by, or may be obtained from local Federal offices.

ITEM I: If the proposal is to redrill to the same reservoir at a different subsurface location or to a new reservoir, use this form with appropriate notations. Consult applicable Federal regulations concerning subsequent work proposals or reports on the well.

ITEM 4: Locations on Federal or Indian land should be described in accordance with Federal requirements. Consult local Federal offices for specific instructions.

ITEM 14: Needed only when location of well cannot readily be found by road from the land or lease description. A plat, or plats, separate or on the reverse side, showing the roads to, and the surveyed location of, the well, and any other required information, should be furnished when required by Federal agency offices.

ITEMS 15 AND 18: If well is to be, or has been directionally drilled, give distances for subsurface location of hole in any present or objective productive zone.

ITEM 22: Consult applicable Federal regulations, or appropriate officials, concerning approval of the proposal before operations are started.

ITEM 24: If the proposal will involve hydraulic fracturing operations, you must comply with 43 CFR 3162.3-3, including providing information about the protection of usable water. Operators should provide the best available information about all formations containing water and their depths. This information could include data and interpretation of resistivity logs run on nearby wells. Information may also be obtained from state or tribal regulatory agencies and from local BLM offices.

NOTICES

The Privacy Act of 1974 and regulation in 43 CFR 2.48(d) provide that you be furnished the following information in connection with information required by this application.

AUTHORITY: 30 U.S.C. 181 et seq., 25 U.S.C. 396; 43 CFR 3160

PRINCIPAL PURPOSES: The information will be used to: (1) process and evaluate your application for a permit to drill a new oil, gas, or service well or to reenter a plugged and abandoned well; and (2) document, for administrative use, information for the management, disposal and use of National Resource Lands and resources including (a) analyzing your proposal to discover and extract the Federal or Indian resources encountered; (b) reviewing procedures and equipment and the projected impact on the land involved; and (c) evaluating the effects of the proposed operation on the surface and subsurface water and other environmental impacts.

ROUTINE USE: Information from the record and/or the record will be transferred to appropriate Federal, State, and local or foreign agencies, when relevant to civil, criminal or regulatory investigations or prosecution, in connection with congressional inquiries and for regulatory responsibilities.

EFFECT OF NOT PROVIDING INFORMATION: Filing of this application and disclosure of the information is mandatory only if you elect to initiate a drilling or reentry operation on an oil and gas lease.

The Paperwork Reduction Act of 1995 requires us to inform you that:

The BLM connects this information to a new evaluation of the technical, safety, and environmental factors involved with drilling for oil and/or gas on Federal and Indian oil and gas leases. This information will be used to analyze and approve applications. Response to this request is mandatory only if the operator elects to initiate drilling or reentry operations on an oil and gas lease. The BLM would like you to know that you do not have to respond to this or any other Federal agency-sponsored information collection unless it displays a currently valid OMB control number.

BURDEN HOURS STATEMENT: Public reporting burden for this form is estimated to average 8 hours per response, including the time for reviewing instructions, gathering and maintaining data, and completing and reviewing the form. Direct comments regarding the burden estimate or any other aspect of this form to U.S. Department of the Interior, Bureau of Land Management (1004-0137), Bureau Information Connection Clearance Officer (WO-630), 1849 C Street, N.W., Mail Stop 401 LS, Washington, D.C. 20240.

Additional Operator Remarks

Location of Well

0. SHL: SESE / 1144 FSL / 165 FEL / TWSP: 20S / RANGE: 28E / SECTION: 8 / LAT: 32.58397 / LONG: -104.19173 (TVD: 0 feet, MD: 0 feet)

PPP: SWSW / 330 FSL / 100 FWL / TWSP: 20S / RANGE: 28E / SECTION: 9 / LAT: 32.58173 / LONG: -104.19091 (TVD: 7329 feet, MD: 7703 feet)

PPP: SWSE / 330 FSL / 0 FWL / TWSP: 20S / RANGE: 28E / SECTION: 9 / LAT: 32.58177 / LONG: -104.18258 (TVD: 7329 feet, MD: 10343 feet)

PPP: SESE / 330 FSL / 0 FEL / TWSP: 20S / RANGE: 28E / SECTION: 9 / LAT: 32.58178 / LONG: -104.17825 (TVD: 7329 feet, MD: 11663 feet)

BHL: SESE / 330 FSL / 10 FEL / TWSP: 20S / RANGE: 28E / SECTION: 10 / LAT: 32.58188 / LONG: -104.15668 (TVD: 7329 feet, MD: 17819 feet)

BLM Point of Contact

Name: JANET D ESTES

Title: ADJUDICATOR

Phone: (575) 234-6233

Email: JESTES@BLM.GOV

Koala 9 FED COM 124H

APD - Geology COAs (Not in Potash or WIPP)

- For at least one well per pad (deepest well within initial development preferred) the record of the drilling rate (ROP) along with the Gamma Ray (GR) and Neutron (CNL) well logs run from TVD to surface in the vertical section of the hole shall be submitted to the BLM office as well as all other logs run on the full borehole 30 days from completion. Any other logs run on the wellbore, excluding cement remediation, should also be sent. Only digital copies of the logs in .TIF or .LAS formats are necessary; paper logs are no longer required. Logs shall be emailed to blm-cfo-geology@doimspp.onmicrosoft.com. Well completion report should have .pdf copies of any CBLs or Temp Logs run on the wellbore.
- Exceptions: In areas where there is extensive log coverage (in particular the salt zone adjacent to a pad), Operators are encouraged to contact BLM Geologists to discuss if additional GR and N logs are necessary on a pad. Operator may request a waiver of the GR and N log requirement due to good well control or other reasons to be approved by BLM Geologist prior to well completion. A waiver approved by BLM must be attached to completion well report to satisfy COAs.
- The top of the Rustler, top and bottom of the Salt, and the top of the Capitan Reef (if present) are to be recorded on the Completion Report.

Be aware that:

- H2S has been reported within one mile of the proposed project. Measurements up to 210 ppm were recorded.

Questions? Contact Thomas Evans, BLM Geologist at 575-234-5965 or tvevans@blm.gov

**PECOS DISTRICT
SURFACE USE
CONDITIONS OF APPROVAL**

OPERATOR'S NAME:	PERMIAN RESOURCES OPERATING LLC
LEASE NO.:	NMNM15003, NMNM137444
COUNTY:	Eddy County, New Mexico

Wells:

Koala North Pad

Koala 9 Fed Com 111H

Surface Hole Location: 362' FEL and 796' FNL, Section 8, T. 20 S., R. 28 E.
Bottom Hole Location: 10' FEL and 990' FNL, Section 10, T. 20 S., R. 28 E.

Koala 9 Fed Com 112H

Surface Hole Location: 332' FEL and 797' FNL, Section 8, T. 20 S., R. 28 E.
Bottom Hole Location: 10' FEL and 2310' FNL, Section 10, T. 20 S., R. 28 E.

Koala 9 Fed Com 121H

Surface Hole Location: 422' FEL and 795' FNL, Section 8, T. 20 S., R. 28 E.
Bottom Hole Location: 10' FEL and 990' FNL, Section 10, T. 20 S., R. 28 E.

Koala 9 Fed Com 131H

Surface Hole Location: 482' FEL and 794' FNL, Section 8, T. 20 S., R. 28 E.
Bottom Hole Location: 10' FEL and 990' FNL, Section 10, T. 20 S., R. 28 E.

Koala South Pad

Koala 9 Fed Com 113H

Surface Hole Location: 135' FEL and 1144' FSL, Section 8, T. 20 S., R. 28 E.
Bottom Hole Location: 10' FEL and 1650' FSL, Section 10, T. 20 S., R. 28 E.

Koala 9 Fed Com 114H

Surface Hole Location: 105' FEL and 1144' FSL, Section 8, T. 20 S., R. 28 E.
Bottom Hole Location: 10' FEL and 330' FSL, Section 10, T. 20 S., R. 28 E.

Koala 9 Fed Com 123H

Surface Hole Location: 195' FEL and 1144' FSL, Section 8, T. 20 S., R. 28 E.
Bottom Hole Location: 10' FEL and 1650' FSL, Section 10, T. 20 S., R. 28 E.

Koala 9 Fed Com 124H

Surface Hole Location: 165' FEL and 1144' FSL, Section 8, T. 20 S., R. 28 E.
Bottom Hole Location: 10' FEL and 330' FSL, Section 10, T. 20 S., R. 28 E.

TABLE OF CONTENTS

- 1. GENERAL PROVISIONS 4
 - 1.1. ARCHAEOLOGICAL, PALEONTOLOGY & HISTORICAL SITES 4
 - 1.2. RANGELAND RESOURCES 4
 - 1.2.1. Cattleguards 4
 - 1.2.2. Fence Requirement 5
 - 1.2.3. Livestock Watering Requirement 5
 - 1.3. NOXIOUS WEEDS..... 5
 - 1.3.1 African Rue (Peganum harmala) 5
 - 1.4. LIGHT POLLUTION 5
 - 1.4.1. Downfacing..... 5
 - 1.4.2. Shielding..... 5
 - 1.4.3. Lighting Color..... 6
- 2. SPECIAL REQUIREMENTS 6
 - CAVE/KARST 6
 - 2.1.1. Residual and Cumulative Mitigation..... 6
 - 2.1.2. Plugging and Abandonment Mitigation..... 6
 - 2.3 SPECIAL STATUS PLANT SPECIES 6
 - 2.4 VISUAL RESOURCE MANAGEMENT..... 6
 - 2.5.1 VRM IV 6
- 3. CONSTRUCTION REQUIREMENTS..... 6
 - 3.1 CONSTRUCTION NOTIFICATION 6
 - 3.2 TOPSOIL 6
 - 3.3 CLOSED LOOP SYSTEM 6
 - 3.4 FEDERAL MINERAL PIT 7
 - 3.5 WELL PAD & SURFACING 7
 - 3.6 EXCLOSURE FENCING (CELLARS & PITS) 7
 - 3.7 ON LEASE ACCESS ROAD..... 7
 - 3.7.1 Road Width 7
 - 3.7.2 Surfacing 7
 - 3.7.3 Crowning..... 7
 - 3.7.4 Ditching 7
 - 3.7.5 Turnouts..... 7
 - 3.7.6 Drainage..... 7
 - 3.7.7 Public Access..... 8

- 5. PRODUCTION (POST DRILLING) 10
 - 5.1 WELL STRUCTURES & FACILITIES 10
 - 5.1.1 Placement of Production Facilities 10
 - 5.1.2 Exclosure Netting (Open-top Tanks) 10
 - 5.1.3. Chemical and Fuel Secondary Containment and Exclosure Screening 10
 - 5.1.4. Open-Vent Exhaust Stack Exclosures 10
 - 5.1.5. Containment Structures 10
- 6. RECLAMATION 10
 - 6.1 ROAD AND SITE RECLAMATION 11
 - 6.2 EROSION CONTROL 11
 - 6.3 INTERIM RECLAMATION 11
 - 6.4 FINAL ABANDONMENT & RECLAMATION 11
 - 6.5 SEEDING TECHNIQUES 12
 - 6.6 SOIL SPECIFIC SEED MIXTURE 12

1. GENERAL PROVISIONS

The failure of the operator to comply with these requirements may result in the assessment of liquidated damages or penalties pursuant to 43 CFR 3163.1 or 3163.2. A copy of these conditions of approval shall be present on the location during construction, drilling and reclamation activity. Any request for a variance shall be submitted to the Authorized Officer on Form 3160-5, Sundry Notices and Report on Wells.

1.1. ARCHAEOLOGICAL, PALEONTOLOGY & HISTORICAL SITES

Any cultural resource (historic or prehistoric site or object) discovered by the operator, or any person working on the operator's behalf, on the public or federal land shall be immediately reported to the Authorized Officer. The operator shall suspend all operations in the immediate area (within 100ft) of such discovery until written authorization to proceed is issued by the Authorized Officer. An evaluation of the discovery will be made by the Authorized Officer, in conjunction with a BLM Cultural Resource Specialist, to determine appropriate actions to prevent the loss of significant scientific values. The operator shall be responsible for the cost of evaluation and any decision as to the proper mitigation measures will be made by the Authorized Officer after consulting with the operator.

Traditional Cultural Properties (TCPs) are protected by NHPA as codified in 36 CFR 800 for possessing traditional, religious, and cultural significance tied to a certain group of individuals. Though there are currently no designated TCPs within the project area or within a mile of the project area, but it is possible for a TCP to be designated after the approval of this project. **If a TCP is designated in the project area after the project's approval, the BLM Authorized Officer will notify the operator of the following conditions and the duration for which these conditions are required.**

1. Temporary halting of all construction, drilling, and production activities to lower noise.
2. Temporary shut-off of all artificial lights at night.

The operator is hereby obligated to comply with procedures established in the Native American Graves Protection and Repatriation Act (NAGPRA), specifically NAGPRA Subpart B regarding discoveries, to protect human remains, associated funerary objects, sacred objects, and objects of cultural patrimony discovered during project work. If any human skeletal remains, funerary objects, sacred objects, or objects of cultural patrimony are discovered at any time during construction, all construction activities shall halt and a BLM-CFO Authorized Officer will be notified immediately. The BLM will then be required to be notified, in writing, within 24 hours of the discovery. The written notification should include the geographic location by county and state, the contents of the discovery, and the steps taken to protect said discovery. You must also include any potential threats to the discovery and a conformation that all activity within 100ft of the discovery has ceased and work will not resume until written certification is issued. All work on the entire project must halt for a minimum of 3 days and work cannot resume until an Authorized Officer grants permission to do so.

Any paleontological resource discovered by the operator, or any person working on the operator's behalf, on public or Federal land shall be immediately reported to the Authorized Officer. The operator shall suspend all operations in the immediate area of such discovery until written authorization to proceed is issued by the Authorized Officer. The operator will be responsible for the cost of evaluation and any decision as to the proper mitigation measures will be made by the Authorized Officer after consulting with the operator.

1.2. RANGELAND RESOURCES

1.2.1. Cattleguards

Where a permanent cattleguard is approved, an appropriately sized cattleguard(s) sufficient to carry out the project shall be installed and maintained at fence crossing(s). Any existing cattleguard(s) on the access road shall be repaired or replaced if they are damaged or have deteriorated beyond practical use. The operator shall be responsible for the condition of the existing cattleguard(s) that are in place and are utilized during lease operations. A gate shall be constructed on one side of the cattleguard and fastened securely to H-braces.

1.2.2. Fence Requirement

Where entry granted across a fence line, the fence must be braced and tied off on both sides of the passageway prior to cutting. Once the work is completed, the fence will be restored to its prior condition, or better. The operator shall notify the private surface landowner or the grazing allotment holder prior to crossing any fence(s).

1.2.3. Livestock Watering Requirement

Any damage to structures that provide water to livestock throughout the life of the well, caused by operations from the well site, must be immediately corrected by the operator. The operator must notify the BLM office (575-234-5972) and the private surface landowner or the grazing allotment holder if any damage occurs to structures that provide water to livestock.

1.3. NOXIOUS WEEDS

The operator shall be held responsible if noxious weeds become established within the areas of operations. Weed control shall be required on the disturbed land where noxious weeds exist, which includes the roads, pads, associated pipeline corridor, and adjacent land affected by the establishment of weeds due to this action. The operator shall consult with the Authorized Officer for acceptable weed control methods, which include following EPA, New Mexico Department of Agriculture, and BLM requirements and policies.

1.3.1 African Rue (*Peganum harmala*)

Spraying: The spraying of African Rue must be completed by a licensed or certified applicator. In order to attempt to kill or remove African Rue the proper mix of chemical is needed. The mix consists of 2% Arsenal (Imazapyr) and 2% Roundup (Glyphosate) along with a nonionic surfactant. Any other chemicals or combinations shall be approved by the BLM Noxious Weeds Coordinator prior to treatment. African Rue shall be sprayed in connection to any dirt working activities or disturbances to the site being sprayed. Spraying of African Rue shall be done on immature plants at initial growth through flowering and mature plants between budding and flowering stages. Spraying shall not be conducted after flowering when plant is fruiting. This will ensure optimal intake of chemical and decrease chances of developing herbicide resistance. After spraying, the operator or necessary parties must contact the Carlsbad Field Office to inspect the effectiveness of the application treatment to the plant species. No ground disturbing activities can take place until the inspection by the authorized officer is complete. The operator may contact the Environmental Protection Department or the BLM Noxious Weed Coordinator at (575) 234-5972 or BLM_NM_CFO_NoxiousWeeds@blm.gov.

Management Practices: In addition to spraying for African Rue, good management practices should be followed. All equipment should be washed off using a power washer in a designated containment area. The containment area shall be bermed to allow for containment of the seed to prevent it from entering any open areas of the nearby landscape. The containment area shall be excavated near or adjacent to the well pad at a depth of three feet and just large enough to get equipment inside it to be washed off. This will allow all seeds to be in a centrally located area that can be treated at a later date if the need arises.

1.4. LIGHT POLLUTION

1.4.1. Downfacing

All permanent lighting will be pointed straight down at the ground in order to prevent light spill beyond the edge of approved surface disturbance.

1.4.2. Shielding

All permanent lighting will use full cutoff luminaires, which are fully shielded (i.e., not emitting direct or indirect light above an imaginary horizontal plane passing through the lowest part of the light source).

1.4.3. Lighting Color

Lighting shall be 3,500 Kelvin or less (Warm White) except during drilling, completion, and workover operations. No bluish-white lighting shall be used in permanent outdoor lighting.

2. SPECIAL REQUIREMENTS

CAVE/KARST

2.1.1. Residual and Cumulative Mitigation

The operator will perform annual pressure monitoring on all casing annuli. If the test results indicate a casing failure has occurred, contact a BLM Engineer immediately, and take remedial action to correct the problem.

2.1.2. Plugging and Abandonment Mitigation

Upon well abandonment in high cave karst areas, additional plugging conditions of approval may be required. The BLM will assess the situation and work with the operator to ensure proper plugging of the wellbore.

2.3 SPECIAL STATUS PLANT SPECIES

2.4 VISUAL RESOURCE MANAGEMENT

2.5.1 VRM IV

Above-ground structures including meter housing that are not subject to safety requirements are painted a flat non-reflective paint color, Shale Green from the BLM Standard Environmental Color Chart (CC-001: June 2008).

3. CONSTRUCTION REQUIREMENTS

3.1 CONSTRUCTION NOTIFICATION

The BLM shall administer compliance and monitor construction of the access road and well pad. Notify the Carlsbad Field Office at BLM_NM_CFO_Construction_Reclamation@blm.gov at least 3 working days prior to commencing construction of the access road and/or well pad.

When construction operations are being conducted on this well, the operator shall have the approved APD and COAs on the well site and they shall be made available upon request by the Authorized Officer.

3.2 TOPSOIL

The operator shall strip the topsoil (the A horizon) from the entire well pad area and stockpile the topsoil along the edge of the well pad as depicted in the APD. No more than the top 6 inches of topsoil shall be removed. All the stockpiled topsoil will be redistributed over the interim reclamation areas. Topsoil shall not be used for berming the pad or facilities. For final reclamation, the topsoil shall be spread over the entire pad area for seeding preparation.

Other subsoil (the B horizon and below) stockpiles must be completely segregated from the topsoil stockpile. Large rocks or subsoil clods (not evident in the surrounding terrain) must be buried within the approved area for interim and final reclamation.

3.3 CLOSED LOOP SYSTEM

Tanks are required for drilling operations: No reserve pits will be used for drill cuttings. The operator shall properly dispose of drilling contents at an authorized disposal site.

3.4 FEDERAL MINERAL PIT

Payment shall be made to the BLM prior to removal of any federal mineral materials. Call the Carlsbad Field Office at (575) 234-5972.

3.5 WELL PAD & SURFACING

Any surfacing material used to surface the well pad will be removed at the time of interim and final reclamation.

3.6 EXCLOSURE FENCING (CELLARS & PITS)

The operator will install and maintain enclosure fencing for all open well cellars to prevent access to public, livestock, and large forms of wildlife before and after drilling operations until the well cellar is free of fluids and the operator initiates backfilling. (For examples of enclosure fencing design, refer to BLM's Oil and Gas Gold Book, Enclosure Fence Illustrations, Figure 1, Page 18.)

The operator will also install and maintain mesh netting for all open well cellars to prevent access to smaller wildlife before and after drilling operations until the well cellar is free of fluids and the operator. Use a maximum netting mesh size of 1 ½ inches. The netting must not have holes or gaps.

3.7 ON LEASE ACCESS ROAD

3.7.1 Road Width

The access road shall have a driving surface that creates the smallest possible surface disturbance and does not exceed fourteen (14) feet in width. The maximum width of surface disturbance, when constructing the access road, shall not exceed twenty-five (25) feet.

3.7.2 Surfacing

Surfacing material is not required on the new access road driving surface. If the operator elects to surface the new access road or pad, the surfacing material may be required to be removed at the time of reclamation.

Where possible, no improvements will be made on the unsurfaced access road other than to remove vegetation as necessary, road irregularities, safety issues, or to fill low areas that may sustain standing water.

The Authorized Officer reserves the right to require surfacing of any portion of the access road at any time deemed necessary. Surfacing may be required in the event the road deteriorates, erodes, road traffic increases, or it is determined to be beneficial for future field development. The surfacing depth and type of material will be determined at the time of notification.

3.7.3 Crowning

Crowning shall be done on the access road driving surface. The road crown shall have a grade of approximately 2% (i.e., a 1" crown on a 14' wide road). The road shall conform to Figure 1; cross section and plans for typical road construction.

3.7.4 Ditching

Ditching shall be required on both sides of the road.

3.7.5 Turnouts

Vehicle turnouts shall be constructed on the road. Turnouts shall be intervisible with interval spacing distance less than 1000 feet. Turnouts shall conform to Figure 1; cross section and plans for typical road construction.

3.7.6 Drainage

Drainage control systems shall be constructed on the entire length of road (e.g. ditches, sidehill outsloping and insloping, leadoff ditches, culvert installation, and low water crossings).

A typical lead-off ditch has a minimum depth of 1 foot below and a berm of 6 inches above natural ground level. The berm shall be on the down-slope side of the lead-off ditch.

Cross Section of a Typical Lead-off Ditch

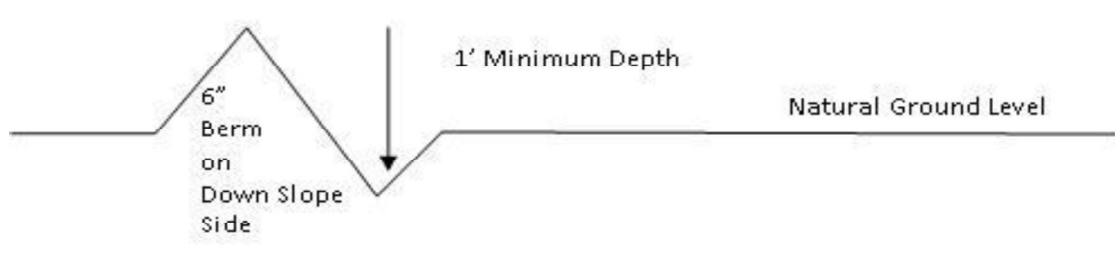

All lead-off ditches shall be graded to drain water with a 1 percent minimum to 3 percent maximum ditch slope. The spacing interval are variable for lead-off ditches and shall be determined according to the formula for spacing intervals of lead-off ditches, but may be amended depending upon existing soil types and centerline road slope (in %);

Formula for Spacing Interval of Lead-off Ditches

Example - On a 4% road slope that is 400 feet long, the water flow shall drain water into a lead-off ditch. Spacing interval shall be determined by the following formula:

$$400 \text{ foot road with } 4\% \text{ road slope: } \frac{400'}{4} + 100' = 200' \text{ lead-off ditch interval}$$

3.7.7 Public Access

Public access on this road shall not be restricted by the operator without specific written approval granted by the Authorized Officer.

- Construction Steps**
1. Salvage topsoil
 2. Construct road
 3. Redistribute topsoil
 4. Revegetate slopes

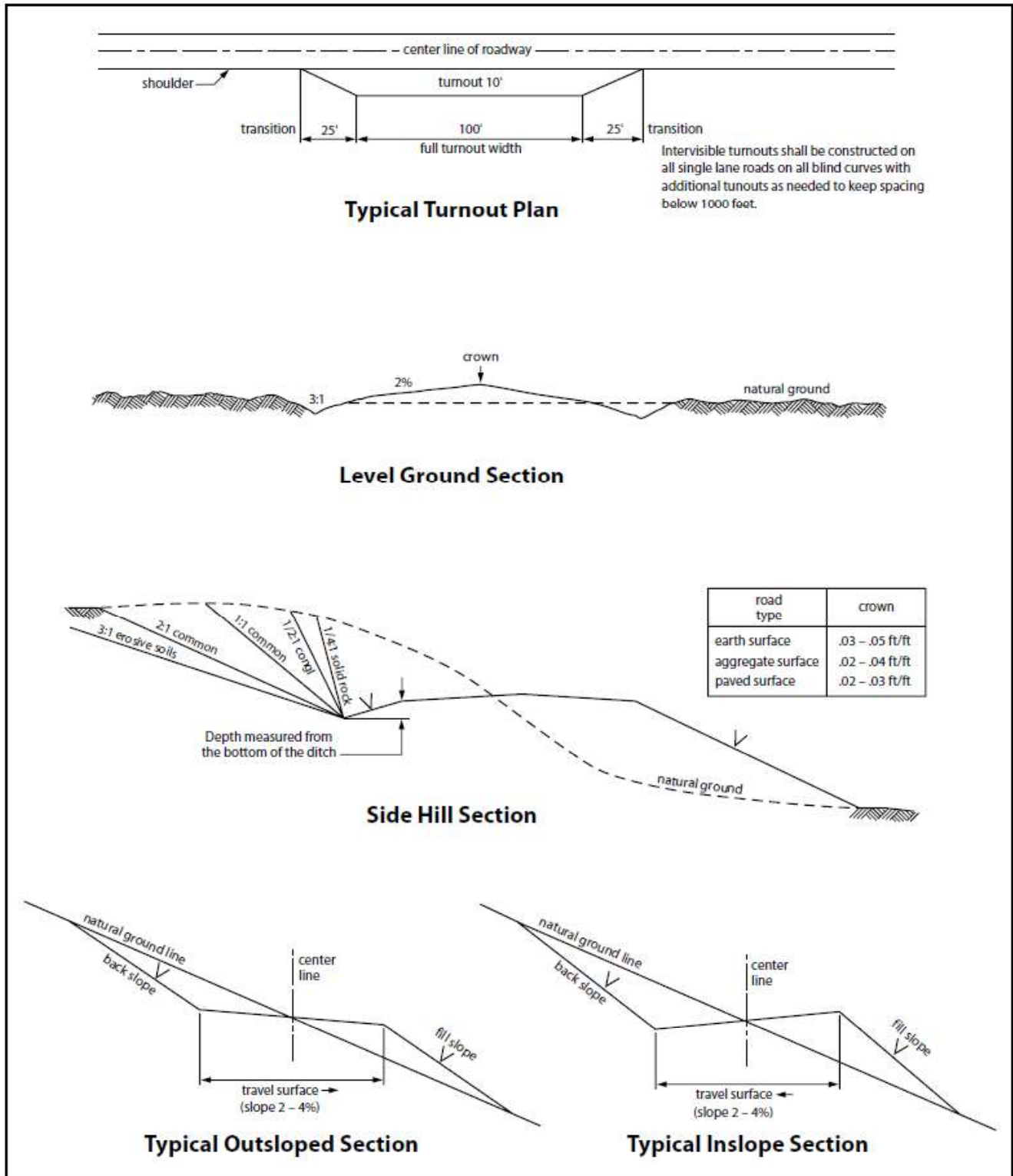

Figure 1. Cross-sections and plans for typical road sections representative of BLM resource or FS local and higher-class roads.

5. PRODUCTION (POST DRILLING)

5.1 WELL STRUCTURES & FACILITIES

5.1.1 Placement of Production Facilities

Production facilities must be placed on the well pad to allow for maximum interim recontouring and revegetation of the well location.

5.1.2 Exclosure Netting (Open-top Tanks)

Immediately following active drilling or completion operations, the operator will take actions necessary to prevent wildlife and livestock access, including avian wildlife, to all open-topped tanks that contain or have the potential to contain salinity sufficient to cause harm to wildlife or livestock, hydrocarbons, or Resource Conservation and Recovery Act of 1976-exempt hazardous substances. At a minimum, the operator will net, screen, or cover open-topped tanks to exclude wildlife and livestock and prevent mortality. If the operator uses netting, the operator will cover and secure the open portion of the tank to prevent wildlife entry. The operator will net, screen, or cover the tanks until the operator removes the tanks from the location or the tanks no longer contain substances that could be harmful to wildlife or livestock. Use a maximum netting mesh size of 1 ½ inches. The netting must not be in contact with fluids and must not have holes or gaps.

5.1.3. Chemical and Fuel Secondary Containment and Exclosure Screening

The operator will prevent all hazardous, poisonous, flammable, and toxic substances from coming into contact with soil and water. At a minimum, the operator will install and maintain an impervious secondary containment system for any tank or barrel containing hazardous, poisonous, flammable, or toxic substances sufficient to contain the contents of the tank or barrel and any drips, leaks, and anticipated precipitation. The operator will dispose of fluids within the containment system that do not meet applicable state or U. S. Environmental Protection Agency livestock water standards in accordance with state law; the operator must not drain the fluids to the soil or ground. The operator will design, construct, and maintain all secondary containment systems to prevent wildlife and livestock exposure to harmful substances. At a minimum, the operator will install effective wildlife and livestock exclosure systems such as fencing, netting, expanded metal mesh, lids, and grate covers. Use a maximum netting mesh size of 1 ½ inches.

5.1.4. Open-Vent Exhaust Stack Exclosures

The operator will construct, modify, equip, and maintain all open-vent exhaust stacks on production equipment to prevent birds and bats from entering, and to discourage perching, roosting, and nesting. (*Recommended exclosure structures on open-vent exhaust stacks are in the shape of a cone.*) Production equipment includes, but may not be limited to, tanks, heater-treaters, separators, dehydrators, flare stacks, in-line units, and compressor mufflers.

5.1.5. Containment Structures

Proposed production facilities such as storage tanks and other vessels will have a secondary containment structure that is constructed to hold the capacity of 1.5 times the largest tank, plus freeboard to account for precipitation, unless more stringent protective requirements are deemed necessary.

6. RECLAMATION

Stipulations required by the Authorized Officer on specific actions may differ from the following general guidelines

6.1 ROAD AND SITE RECLAMATION

Any roads constructed during the life of the well will have the caliche removed or linear burial. If contaminants are indicated then testing will be required for chlorides and applicable contaminate anomalies for final disposal determination (disposed of in a manner approved by the Authorized Officer within Federal, State and Local statutes, regulations, and ordinances) and seeded to the specifications in sections 6.5 and 6.6.

6.2 EROSION CONTROL

Install erosion control berms, windrows, and hummocks. Windrows must be level and constructed perpendicular to down-slope drainage; steeper slopes will require greater windrow density. Topsoil between windrows must be ripped to a depth of at least 12", unless bedrock is encountered. Any large boulders pulled up during ripping must be deep-buried on location. Ripping must be perpendicular to down-slope. The surface must be left rough in order to catch and contain rainfall on-site. Any trenches resulting from erosion cause by run-off shall be addressed immediately.

6.3 INTERIM RECLAMATION

During the life of the development, all disturbed areas not needed for active support of production operations must undergo interim reclamation in order to minimize the environmental impacts of development on other resources and uses.

Within six (6) months of well completion, operators must work with BLM surface protection specialists (BLM_NM_CFO_Construction_Reclamation@blm.gov) to devise the best strategies to reduce the size of the location. Interim reclamation must allow for remedial well operations, as well as safe and efficient removal of oil and gas.

During reclamation, the removal of caliche and any other surface material is required. Removed caliche that is free of contaminants may be used for road repairs, fire walls or for building other roads and locations. In order to operate the well or complete workover operations, it may be necessary to drive, park and operate on restored interim vegetation within the previously disturbed area. Disturbing revegetated areas for production or workover operations will be allowed. If there is significant disturbance and loss of vegetation, the area will need to be revegetated. Communicate with the appropriate BLM office for any exceptions/exemptions if needed.

All disturbed areas after they have been satisfactorily prepared need to be reseeded with the seed mixture provided in section 6.6.

Upon completion of interim reclamation, the operator shall submit a Sundry Notice, Subsequent Report of Reclamation (Form 3160-5).

6.4 FINAL ABANDONMENT & RECLAMATION

Prior to surface abandonment, the operator shall submit a Notice of Intent Sundry Notice and reclamation plan.

At final abandonment, well locations, production facilities, and access roads must undergo "final" reclamation so that the character and productivity of the land are restored.

Earthwork for final reclamation must be completed within six (6) months of well plugging. All pads, pits, facility locations and roads must be reclaimed to a satisfactory revegetated, safe, and stable condition, unless an agreement is made with the landowner or BLM to keep the road and/or pad intact.

After all disturbed areas have been satisfactorily prepared, these areas need to be revegetated with the seed mixture provided below. Seeding will be accomplished by drilling on the contour whenever practical or by other approved methods. Seeding may need to be repeated until revegetation is successful, as determined by the BLM. After earthwork and seeding is completed, the operator is required to submit a Sundry Notice, Subsequent Report of Reclamation.

Operators shall contact a BLM surface protection specialist prior to surface abandonment operations for site specific objectives (BLM_NM_CFO_Construction_Reclamation@blm.gov).

6.5 SEEDING TECHNIQUES

Seeds shall be hydro-seeded, mechanically drilled, or broadcast, with the broadcast-seeded area raked, ripped or dragged to aid in covering the seed. The seed mixture shall be evenly and uniformly planted over the disturbed area.

6.6 SOIL SPECIFIC SEED MIXTURE

The lessee/permittee shall seed all disturbed areas with the seed mixture listed below. The seed mixture shall be planted in the amounts specified in pounds of pure live seed (PLS)* per acre. There shall be no primary or secondary noxious weeds in the seed mixture. Seed will be tested and the viability testing of seed will be done in accordance with State law(s) and within nine (9) months prior to purchase. Commercial seed will be either certified or registered seed. The seed container will be tagged in accordance with State law(s) and available for inspection by the Authorized Officer.

Seed land application will be accomplished by mechanical planting using a drill equipped with a depth regulator to ensure proper depth of planting where drilling is possible. The seed mixture will be evenly and uniformly planted over the disturbed area. Smaller/heavier seeds tend to drop the bottom of the drill and are planted first; the operator shall take appropriate measures to ensure this does not occur. Where drilling is not possible, seed will be broadcast and the area shall be raked or chained to cover the seed. When broadcasting the seed, the pounds per acre are to be doubled. The seeding will be repeated until a satisfactory BLM or Soil Conservation

District stand is established as determined by the Authorized Officer. Evaluation of growth will not be made before completion of at least one full growing season after seeding or until several months of precipitation have occurred, enabling a full four months of growth, with one or more seed generations being established.

Seed Mixture 1 for Loamy Sites

Species to be planted in pounds of pure live seed* per acre:

<u>Species</u>	<u>lb/acre</u>
Plains lovegrass (Eragrostis intermedia)	0.5
Sand dropseed (Sporobolus cryptandrus)	1.0
Sideoats grama (Bouteloua curtipendula)	5.0
Plains bristlegrass (Setaria macrostachya)	2.0

*Pounds of pure live seed:

Pounds of seed x percent purity x percent germination = pounds pure live seed

Seed Mixture 2, for Sandy Site

Species to be planted in pounds of pure live seed* per acre:

<u>Species</u>	<u>lb/acre</u>
Sand dropseed (Sporobolus cryptandrus)	1.0
Sand love grass (Eragrostis trichodes)	1.0
Plains bristlegrass (Setaria macrostachya)	2.0

*Pounds of pure live seed:

Pounds of seed x percent purity x percent germination = pounds pure live seed

PECOS DISTRICT DRILLING CONDITIONS OF APPROVAL

OPERATOR'S NAME: Permian Resources Operating LLC
WELL NAME & NO.: Koala 9 Fed Com 124H
LOCATION: Sec 08-20S-528E-NMP
COUNTY: Eddy County, New Mexico

Create COAs

<p style="text-align: center;">H₂S</p> <div style="border: 1px solid black; padding: 2px; text-align: center;">Present</div>	<p style="text-align: center;">Cave / Karst</p> <div style="border: 1px solid black; padding: 2px; text-align: center;">High</div>	<p style="text-align: center;">Waste Prevention Rule</p> <div style="border: 1px solid black; padding: 2px; text-align: center;">Waste Minimization Plan</div>
<p style="text-align: center;">Potash</p> <div style="border: 1px solid black; padding: 2px; text-align: center;">None</div>	<p style="text-align: center;">R-111-Q Design</p> <div style="border: 1px solid black; height: 20px; width: 100%;"></div>	
<p style="text-align: center;">Wellhead</p> <div style="border: 1px solid black; padding: 2px; text-align: center;">Multibowl</div> <p><input checked="" type="checkbox"/> Flex Hose</p> <p><input checked="" type="checkbox"/> Break Testing</p>	<p style="text-align: center;">Casing</p> <div style="border: 1px solid black; padding: 2px; text-align: center;">3-String Well</div> <p> <input type="checkbox"/> Liner <input type="checkbox"/> Fluid Filled <input type="checkbox"/> Casing Clearance </p>	
	<p style="text-align: center;">Cementing</p> <p> <input type="checkbox"/> DV Tool <input type="checkbox"/> Bradenhead <input type="checkbox"/> Echometer </p> <p> <input checked="" type="checkbox"/> Offline Cement <input type="checkbox"/> Open Annulus <input type="checkbox"/> Pilot Hole </p>	
<p style="text-align: center;">Special Requirements</p> <p> <input checked="" type="checkbox"/> Capitan Reef <input type="checkbox"/> Water Disposal <input checked="" type="checkbox"/> COM <input type="checkbox"/> Unit </p>		

A. HYDROGEN SULFIDE

A Hydrogen Sulfide (H₂S) Drilling Plan shall be activated **at surface**. As a result, the Hydrogen Sulfide area must meet all requirements from 43 CFR 3176, which includes equipment and personnel/public protection items. If Hydrogen Sulfide is encountered, please provide measured values and formations to the BLM.

B. CASING

1. The **13-3/8** inch surface casing shall be set at approximately **260** feet (a minimum of **70'** into the Rustler Anhydrite, above the salt, and below usable fresh water) and cemented to the surface. **Set depth adjusted per BLM geologist.**
 - a. If cement does not circulate to the surface, the appropriate BLM office shall be notified and a temperature survey utilizing an electronic-type temperature survey with surface log readout will be used or a cement bond log shall be run to verify the top of the

- cement. Temperature survey will be run a minimum of six hours after pumping cement and ideally between 8-10 hours after completing the cement job.
- b. Wait on cement (WOC) time for a primary cement job will be a minimum of **8 hours or 500 pounds compressive strength**, whichever is greater (including lead cement.)
 - c. Wait on cement (WOC) time for a remedial job will be a minimum of 4 hours after bringing cement to surface or 500 pounds compressive strength, whichever is greater.
 - d. If cement falls back, remedial cementing will be done prior to drilling out that string.
2. The minimum required fill of cement behind the **9-5/8** inch intermediate casing (set at **2030'** per BLM geologist) is **cement to surface**. If cement does not circulate, see B.1.a, c-d above.
 - **Special Capitan Reef requirements.** If lost circulation (50% or greater) occurs below the Base of the Salt, the operator shall do the following:
 - Switch to freshwater mud to protect the Capitan Reef and use freshwater mud until setting the intermediate casing. The appropriate BLM office is to be notified for a PET to witness the switch to fresh water.
 - Daily drilling reports from the Base of the Salt to the setting of the intermediate casing are to be submitted to the BLM CFO engineering staff via e-mail by 0800 hours each morning. Any lost circulation encountered is to be recorded on these drilling reports. The daily drilling report should show mud volume per shift/tour. Failure to submit these reports will result in an Incidence of Non-Compliance being issued for failure to comply with the Conditions of Approval. If not already planned, the operator shall run a caliper survey for the intermediate well bore and submit to the appropriate BLM office.
 - **Wait on cement (WOC) time for a primary cement job is to include the lead cement slurry** due to the presence of cave/karst, Capitan Reef, or potash features.
 3. The minimum required fill of cement behind the **5-1/2** inch **production** casing is at least **50 feet on top of Capitan Reef top or 200 feet into the previous casing, whichever is greater**. If cement does not circulate see B.1.a, c-d above.
 - If cement does not circulate to surface on the previous casing, this string must come to surface.
 - **Wait on cement (WOC) time for a primary cement job is to include the lead cement slurry** due to the presence of cave/karst, Capitan Reef, or potash features.

C. PRESSURE CONTROL

1. Operator has proposed a multi-bowl wellhead assembly. Minimum working pressure of the blowout preventer (BOP) and related equipment (BOPE) required for drilling below the surface casing shoe shall be **5000 (5M)** psi.
 - a. Wellhead shall be installed by manufacturer's representatives, submit documentation with subsequent sundry.

- b. If the welding is performed by a third party, the manufacturer's representative shall monitor the temperature to verify that it does not exceed the maximum temperature of the seal.
 - c. Manufacturer representative shall install the test plug for the initial BOP test.
 - d. If the cement does not circulate and one-inch operations would have been possible with a standard wellhead, the well head shall be cut off, cementing operations performed and another wellhead installed.
 - e. Whenever any seal subject to test pressure is broken, all the tests in 43 CFR 3172 must be followed.
2. Variance approved to use flex line from BOP to choke manifold. Manufacturer's specification to be readily available. No external damage to flex line. Flex line to be installed as straight as possible (no hard bends).
3. Break testing has been approved for this well ONLY on those intervals utilizing a 5M BOPE or less. (**Annular preventer must be tested to a minimum of 70% of BOPE working pressure and shall be higher than the MASP.**) If in the event break testing is not utilized, then a full BOPE test would be conducted.
 - a. Variance only pertains to the intermediate hole-sections and no deeper than the Bone Springs formation. **BOPE Break Testing is NOT permitted to drill the production hole section.**
 - b. While in transfer between wells, BOPE shall be secured by the hydraulic carrier or cradle.
 - c. A full BOPE test is required prior to drilling the first deep intermediate hole section. If any subsequent hole interval is deeper than the first, a full BOPE test will be required. (200' TVD tolerance between intermediate shoes is allowable).
 - d. As a minimum, a full BOPE test shall be performed at 21-day intervals.
 - e. In the event any repairs or replacement of the BOPE is required, the BOPE shall test as per **43 CFR 3172**. Any well control event while drilling require notification to the BLM Petroleum Engineer (**575-706-2779**) prior to the commencement of any BOPE Break Testing operations.

D. SPECIAL REQUIREMENT(S)

Communitization Agreement:

- The operator will submit a Communitization Agreement to the Santa Fe Office, 301 Dinosaur Trail Santa Fe, New Mexico 87508, at least 90 days before the anticipated date of first production from a well subject to a spacing order issued by the New Mexico Oil Conservation Division. The Communitization Agreement will include the signatures of all working interest owners in all Federal and Indian leases subject to the Communitization Agreement (i.e., operating rights owners and lessees of record), or certification that the

operator has obtained the written signatures of all such owners and will make those signatures available to the BLM immediately upon request.

- The operator will submit an as-drilled survey well plat of the well completion, but are not limited to, those specified in 43 CFR 3171 and 3172.
- If the operator does not comply with this condition of approval, the BLM may take enforcement actions that include, but are not limited to, those specified in 43 CFR 3163.1.
- In addition, the well sign shall include the surface and bottom hole lease numbers. When the Communitization Agreement number is known, it shall also be on the sign.

Offline Cementing

Offline cementing has been approved for **all hole sections, excluding production**. Contact the BLM prior to the commencement of any offline cementing procedure.

GENERAL REQUIREMENTS

The BLM is to be notified in advance for a representative to witness:

- a. Spudding well (minimum of 24 hours)
- b. Setting and/or Cementing of all casing strings (minimum of 4 hours)
- c. BOPE tests (minimum of 4 hours)

Contact Eddy County Petroleum Engineering Inspection Staff:

Email or call the Carlsbad Field Office, 620 East Greene St., Carlsbad, NM 88220;
[BLM NM CFO DrillingNotifications@BLM.GOV](mailto:BLM_NM_CFO_DrillingNotifications@BLM.GOV); (575) 361-2822

1. Unless the production casing has been run and cemented or the well has been properly plugged, the drilling rig shall not be removed from over the hole without prior approval.
 - a. In the event the operator has proposed to drill multiple wells utilizing a skid/walking rig. Operator shall secure the wellbore on the current well, after installing and testing the wellhead, by installing a blind flange of like pressure rating to the wellhead and a pressure gauge that can be monitored while drilling is performed on the other well(s).
 - b. When the operator proposes to set surface casing with Spudder Rig
 - i. Notify the BLM when moving in and removing the Spudder Rig.
 - ii. Notify the BLM when moving in the 2nd Rig. Rig to be moved in within 90 days of notification that Spudder Rig has left the location.
 - iii. BOP/BOPE test to be conducted per **43 CFR 3172** as soon as 2nd Rig is rigged up on well.
2. Floor controls are required for 3M or Greater systems. These controls will be on the rig floor, unobstructed, readily accessible to the driller and will be operational at all times during drilling and/or completion activities. Rig floor is defined as the area immediately around the rotary table; the area immediately above the substructure on which the draw works are located, this does not include the dog house or stairway area.
3. For intervals in which cement to surface is required, cement to surface should be verified with a visual check and density or pH check to differentiate cement from spacer and drilling mud. The results should be documented in the driller's log and daily reports.

A. CASING

1. Changes to the approved APD casing program need prior approval if the items substituted are of lesser grade or different casing size or are Non-API. The Operator can exchange the components of the proposal with that of superior strength (i.e. changing from J-55 to N-80, or from 36# to 40#). Changes to the approved cement program need prior approval if the altered cement plan has less volume or strength or

- if the changes are substantial (i.e. Multistage tool, ECP, etc.). The initial wellhead installed on the well will remain on the well with spools used as needed.
2. Wait on cement (WOC) for Potash Areas: After cementing but before commencing any tests, the casing string shall stand cemented under pressure until both of the following conditions have been met: 1) cement reaches a minimum compressive strength of 500 psi for all cement blends of both lead and tail cement, 2) until cement has been in place at least 8 hours. WOC time will be recorded in the driller's log. The casing integrity test can be done (prior to the cement setting up) immediately after bumping the plug.
 3. Wait on cement (WOC) for Water Basin: After cementing but before commencing any tests, the casing string shall stand cemented under pressure until both of the following conditions have been met: 1) cement reaches a minimum compressive strength of 500 psi at the shoe, 2) until cement has been in place at least 8 hours. WOC time will be recorded in the driller's log. See individual casing strings for details regarding lead cement slurry requirements. The casing integrity test can be done (prior to the cement setting up) immediately after bumping the plug.
 4. Provide compressive strengths including hours to reach required 500 pounds compressive strength prior to cementing each casing string. Have well specific cement details onsite prior to pumping the cement for each casing string.
 5. No pea gravel permitted for remedial or fall back remedial without prior authorization from the BLM engineer.
 6. On that portion of any well approved for a 5M BOPE system or greater, a pressure integrity test of each casing shoe shall be performed. Formation at the shoe shall be tested to a minimum of the mud weight equivalent anticipated to control the formation pressure to the next casing depth or at total depth of the well. This test shall be performed before drilling more than 20 feet of new hole.
 7. If hardband drill pipe is rotated inside casing, returns will be monitored for metal. If metal is found in samples, drill pipe will be pulled and rubber protectors which have a larger diameter than the tool joints of the drill pipe will be installed prior to continuing drilling operations.
 8. Whenever a casing string is cemented in the R-111-Q potash area, the NMOCD requirements shall be followed.

B. PRESSURE CONTROL

1. All blowout preventer (BOP) and related equipment (BOPE) shall comply with well control requirements as described in **43 CFR 3172**.
2. If a variance is approved for a flexible hose to be installed from the BOP to the choke manifold, the following requirements apply: The flex line must meet the requirements of API 16C. Check condition of flexible line from BOP to choke manifold, replace if exterior is damaged or if line fails test. Line to be as straight as possible with no hard bends and is to be anchored according to Manufacturer's requirements. The flexible

- hose can be exchanged with a hose of equal size and equal or greater pressure rating. Anchor requirements, specification sheet and hydrostatic pressure test certification matching the hose in service, to be onsite for review. These documents shall be posted in the company man's trailer and on the rig floor.
3. 5M or higher system requires an HCR valve, remote kill line and annular to match. The remote kill line is to be installed prior to testing the system and tested to stack pressure.
 4. If the operator has proposed a multi-bowl wellhead assembly in the APD. The following requirements must be met:
 - i. Wellhead shall be installed by manufacturer's representatives, submit documentation with subsequent sundry.
 - ii. If the welding is performed by a third party, the manufacturer's representative shall monitor the temperature to verify that it does not exceed the maximum temperature of the seal.
 - iii. Manufacturer representative shall install the test plug for the initial BOP test.
 - iv. Whenever any seal subject to test pressure is broken, all the tests in 43 CFR 3172.6(b)(9) must be followed.
 - v. If the cement does not circulate and one inch operations would have been possible with a standard wellhead, the well head shall be cut off, cementing operations performed and another wellhead installed.
 5. The appropriate BLM office shall be notified a minimum of 4 hours in advance for a representative to witness the tests.
 - i. In a water basin, for all casing strings utilizing slips, these are to be set as soon as the crew and rig are ready and any fallback cement remediation has been done. The casing cut-off and BOP installation can be initiated four hours after installing the slips, which will be approximately six hours after bumping the plug. For those casing strings not using slips, the minimum wait time before cut-off is eight hours after bumping the plug. BOP/BOPE testing can begin after cut-off or once cement reaches 500 psi compressive strength (including lead cement), whichever is greater. However, if the float does not hold, cut-off cannot be initiated until cement reaches 500 psi compressive strength (including lead when specified).
 - ii. In potash areas, for all casing strings utilizing slips, these are to be set as soon as the crew and rig are ready and any fallback cement remediation has been done. For all casing strings, casing cut-off and BOP installation can be initiated at twelve hours after bumping the cement plug. The BOPE test can be initiated after bumping the cement plug with the casing valve open. (only applies to single stage cement jobs, prior to the cement setting up.)
 - iii. The tests shall be done by an independent service company utilizing a test plug not a cup or J-packer and can be initiated immediately with the casing valve

open. The operator also has the option of utilizing an independent tester to test without a plug (i.e. against the casing) pursuant to **43 CFR 3172** with the pressure not to exceed 70% of the burst rating for the casing. Any test against the casing must meet the WOC time for 8 hours or 500 pounds compressive strength, whichever is greater, prior to initiating the test (see casing segment as lead cement may be critical item).

- iv. The test shall be run on a 5000 psi chart for a 2-3M BOP/BOP, on a 10000 psi chart for a 5M BOP/BOPE and on a 15000 psi chart for a 10M BOP/BOPE. If a linear chart is used, it shall be a one hour chart. A circular chart shall have a maximum 2 hour clock. If a twelve hour or twenty-four hour chart is used, tester shall make a notation that it is run with a two hour clock.
- v. The results of the test shall be reported to the appropriate BLM office.
- vi. All tests are required to be recorded on a calibrated test chart. A copy of the BOP/BOPE test chart and a copy of independent service company test will be submitted to the appropriate BLM office.
- vii. The BOP/BOPE test shall include a low pressure test from 250 to 300 psi. The test will be held for a minimum of 10 minutes if test is done with a test plug and 30 minutes without a test plug. This test shall be performed prior to the test at full stack pressure.
- viii. BOP/BOPE must be tested by an independent service company within 500 feet of the top of the Wolfcamp formation if the time between the setting of the intermediate casing and reaching this depth exceeds 20 days. This test does not exclude the test prior to drilling out the casing shoe as per **43 CFR 3172**.

C. DRILLING MUD

Mud system monitoring equipment, with derrick floor indicators and visual and audio alarms, shall be operating before drilling into the Wolfcamp formation, and shall be used until production casing is run and cemented.

D. WASTE MATERIAL AND FLUIDS

All waste (i.e. drilling fluids, trash, salts, chemicals, sewage, gray water, etc.) created as a result of drilling operations and completion operations shall be safely contained and disposed of properly at a waste disposal facility. No waste material or fluid shall be disposed of on the well location or surrounding area. Porto-johns and trash containers will be on-location during fracturing operations or any other crew-intensive operations.

Operator

I hereby certify that I, or someone under my direct supervision, have inspected the drill site and access route proposed herein; that I am familiar with the conditions which currently exist; that I have full knowledge of state and Federal laws applicable to this operation; that the statements made in this APD package are, to the best of my knowledge, true and correct; and that the work associated with the operations proposed herein will be performed in conformity with this APD package and the terms and conditions under which it is approved. I also certify that I, or the company I represent, am responsible for the operations conducted under this application. These statements are subject to the provisions of 18 U.S.C. 1001 for the filing of false statements.

NAME: CASSIE EVANS

Signed on: 10/29/2025

Title: Regulatory Specialist

Street Address: 300 N MARIENFELD ST STE 1000

City: MIDLAND

State: TX

Zip: 79701

Phone: (432)260-4388

Email address: CASSIE.EVANS@PERMIANRES.COM

Field

Representative Name:

Street Address:

City:

State:

Zip:

Phone:

Email address:

APD ID: 10400108077 **Submission Date:** 10/30/2025
Operator Name: PERMIAN RESOURCES OPERATING LLC
Well Name: KOALA 9 FED COM **Well Number:** 124H
Well Type: CONVENTIONAL GAS WELL **Well Work Type:** Drill

Highlighted data
reflects the most
recent changes
[Show Final Text](#)

Section 1 - General

APD ID: 10400108077 **Tie to previous NOS?** **Submission Date:** 10/30/2025
BLM Office: Carlsbad **User:** CASSIE EVANS **Title:** Regulatory Specialist
Federal/Indian APD: FED **Is the first lease penetrated for production Federal or Indian?** FED
Lease number: NMNM15003 **Lease Acres:**
Surface access agreement in place? **Allotted?** **Reservation:**
Agreement in place? NO **Federal or Indian agreement:**
Agreement number:
Agreement name:
Keep application confidential? N
Permitting Agent? NO **APD Operator:** PERMIAN RESOURCES OPERATING LLC
Operator letter of

Operator Info

Operator Organization Name: PERMIAN RESOURCES OPERATING LLC
Operator Address: 300 N MARIENFELD ST SUITE 1000 **Zip:** 79701
Operator PO Box:
Operator City: MIDLAND **State:** TX
Operator Phone: (432)695-4222
Operator Internet Address:

Section 2 - Well Information

Well in Master Development Plan? NO **Master Development Plan name:**
Well in Master SUPO? NO **Master SUPO name:**
Well in Master Drilling Plan? NO **Master Drilling Plan name:**
Well Name: KOALA 9 FED COM **Well Number:** 124H
Field/Pool or Exploratory? Field and Pool **Field Name:** BURTON FLAT **Pool Name:** MORROW (PRO GAS)

Well Name: KOALA 9 FED COM **Well Number:** 124H

Is the proposed well in an area containing other mineral resources? USEABLE WATER,NATURAL GAS,OIL

Is the proposed well in a Helium production area? N Use Existing Well Pad? N New surface disturbance?

Type of Well Pad: MULTIPLE WELL **Multiple Well Pad Name:** Koala **Number:** 2
 South Pad
Well Class: HORIZONTAL **Number of Legs:** 1

Well Work Type: Drill

Well Type: CONVENTIONAL GAS WELL

Describe Well Type:

Well sub-Type: INFILL

Describe sub-type:

Distance to town: **Distance to nearest well:** 30 FT **Distance to lease line:** 165 FT

Reservoir well spacing assigned acres Measurement: 320 Acres

Well plat: Koala_9_Fed_Com_124H_C102_20251205053229.pdf

Well work start Date: 04/27/2026 **Duration:** 45 DAYS

Section 3 - Well Location Table

Survey Type: RECTANGULAR

Describe Survey Type:

Datum: NAD83 **Vertical Datum:** NAVD88

Survey number: 12177 **Reference Datum:** GROUND LEVEL

Wellbore	NS-Foot	NS Indicator	EW-Foot	EW Indicator	Twsp	Range	Section	Aliquot/Lot/Tract	Latitude	Longitude	County	State	Meridian	Lease Type	Lease Number	Elevation	MD	TVD	Will this well produce from this
SHL Leg #1	114 4	FSL	165	FEL	20S	28E	8	Aliquot SESE	32.58397	- 104.1917 3	EDD Y	NEW MEXI CO	NEW MEXI CO	F	FEE	327 4			Y
KOP Leg #1	114 4	FSL	165	FEL	20S	28E	8	Aliquot SESE	32.58397	- 104.1917 3	EDD Y	NEW MEXI CO	NEW MEXI CO	F	FEE	- 357 8	695 3	685 2	Y
PPP Leg #1-1	330	FSL	100	FW L	20S	28E	9	Aliquot SWS W	32.58173	- 104.1909 1	EDD Y	NEW MEXI CO	NEW MEXI CO	F	NMNM 15003	- 405 5	770 3	732 9	Y

Well Name: KOALA 9 FED COM

Well Number: 124H

Wellbore	NS-Foot	NS Indicator	EW-Foot	EW Indicator	Twsp	Range	Section	Aliquot/Lot/Tract	Latitude	Longitude	County	State	Meridian	Lease Type	Lease Number	Elevation	MD	TVD	Will this well produce from this
PPP Leg #1-2	330	FSL	0	FWL	20S	28E	9	Aliquot SWSE	32.58177	-104.18258	EDD Y	NEW MEXICO	NEW MEXICO	F	NMNM 13232	-4055	10343	7329	Y
PPP Leg #1-3	330	FSL	0	FEL	20S	28E	9	Aliquot SESE	32.58178	-104.17825	EDD Y	NEW MEXICO	NEW MEXICO	F	NMNM 16101	-4055	11663	7329	Y
EXIT Leg #1	330	FSL	100	FEL	20S	28E	10	Aliquot SESE	32.58188	-104.15698	EDD Y	NEW MEXICO	NEW MEXICO	F	NMNM 15003	-4055	17719	7329	Y
BHL Leg #1	330	FSL	10	FEL	20S	28E	10	Aliquot SESE	32.58188	-104.15668	EDD Y	NEW MEXICO	NEW MEXICO	F	NMNM 15003	-4055	17819	7329	Y

C-102 Submit Electronically Via OCD Permitting	State of New Mexico Energy, Minerals & Natural Resources Department OIL CONSERVATION DIVISION	Revised July 9, 2024 Submittal Type: <input checked="" type="checkbox"/> Initial Submittal <input type="checkbox"/> Amended Report <input type="checkbox"/> As Drilled
---	--	--

WELL LOCATION INFORMATION

API Number 30-015-57790	Pool Code 73280	Pool Name Burton Flat, Morrow (PRO GAS)
Property Code 335840	Property Name KOALA 9 FED COM	Well Number 124H
OGRID No. 372165	Operator Name PERMIAN RESOURCES OPERATING, LLC	Ground Level Elevation 3274.09'
Surface Owner: <input type="checkbox"/> State <input checked="" type="checkbox"/> Fee <input type="checkbox"/> Tribal <input type="checkbox"/> Federal		Mineral Owner: <input type="checkbox"/> State <input type="checkbox"/> Fee <input type="checkbox"/> Tribal <input checked="" type="checkbox"/> Federal

Surface Location

UL	Section	Township	Range	Lot	Ft. from N/S	Ft. from E/W	Latitude	Longitude	County
P	8	20-S	28-E		1144' S	165' E	32.58397	-104.19173	EDDY

Bottom Hole Location

UL	Section	Township	Range	Lot	Ft. from N/S	Ft. from E/W	Latitude	Longitude	County
P	10	20-S	28-E		330' S	10' E	32.58188	-104.15668	EDDY

Dedicated Acres 320	Infill or Defining Well Infill	Defining Well API 30-015-54262	Overlapping Spacing Unit (Y/N) N	Consolidation Code C
Order Numbers. TBD			Well setbacks are under Common Ownership: <input checked="" type="checkbox"/> Yes <input type="checkbox"/> No	

Kick Off Point (KOP)

UL	Section	Township	Range	Lot	Ft. from N/S	Ft. from E/W	Latitude	Longitude	County
P	8	20-S	28-E		1144' S	165' E	32.58397	-104.19173	EDDY

First Take Point (FTP)

UL	Section	Township	Range	Lot	Ft. from N/S	Ft. from E/W	Latitude	Longitude	County
M	9	20-S	28-E		330' S	100' W	32.58173	-104.19091	EDDY

Last Take Point (LTP)

UL	Section	Township	Range	Lot	Ft. from N/S	Ft. from E/W	Latitude	Longitude	County
P	10	20-S	28-E		330' S	100' E	32.58188	-104.15698	EDDY

Unitized Area or Area of Uniform Interest NA	Spacing Unit Type <input checked="" type="checkbox"/> Horizontal <input type="checkbox"/> Vertical	Ground Floor Elevation: TBD
---	--	-----------------------------

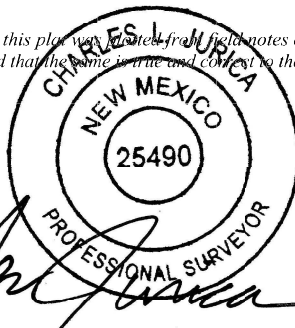
<p>OPERATOR CERTIFICATIONS</p> <p><i>I hereby certify that the information contained herein is true and complete to the best of my knowledge and belief, and, if the well is a vertical or directional well, that this organization either owns a working interest or unleased mineral interest in the land including the proposed bottom hole location or has a right to drill this well at this location pursuant to a contract with an owner of a working interest or unleased mineral interest, or to a voluntary pooling agreement or a compulsory pooling order heretofore entered by the division.</i></p> <p><i>If this well is a horizontal well, I further certify that this organization has received the consent of at least one lessee or owner of a working interest or unleased mineral interest in each tract (in the target pool or formation) in which any part of the well's completed interval will be located or obtained a compulsory pooling order from the division.</i></p>	<p>SURVEYOR CERTIFICATIONS</p> <p><i>I hereby certify that the well location shown on this plot was taken from field notes of actual surveys made by me or under my supervision, and that the same is true and correct to the best of my beliefs.</i></p> <p style="text-align: right;">10/20/2025</p> <div style="text-align: right;">  Signature and Seal of Professional Surveyor </div>
Signature <i>Cassie Evans</i>	Date 10/24/25
Printed Name Cassie Evans	Certificate Number
Email Address cassie.evans@permianres.com	Date of Survey

Note: No allowable will be assigned to this completion until all interests have been consolidated or a non-standard unit has been approved by the division.

ACREAGE DEDICATION PLATS

This grid represents a standard section. You may superimpose a non-standard section, or larger area, over this grid. Operators must outline the dedicated acreage in a red box, clearly show the well surface location and bottom hole location, if it is directionally drilled, with the dimensions from the section lines in the cardinal directions. If this is a horizontal wellbore show on this plat the location of the First Take Point and Last Take Point, and the point within the Completed interval (other than the First Take Point or Last Take Point) that is closest to any outer boundary of the tract.

Surveyors shall use the latest United States government survey or dependent resurvey. Well locations will be in reference to the New Mexico Principal Meridian. If the land is not surveyed, contact the OCD Engineering Bureau. Independent subdivision surveys will not be acceptable.

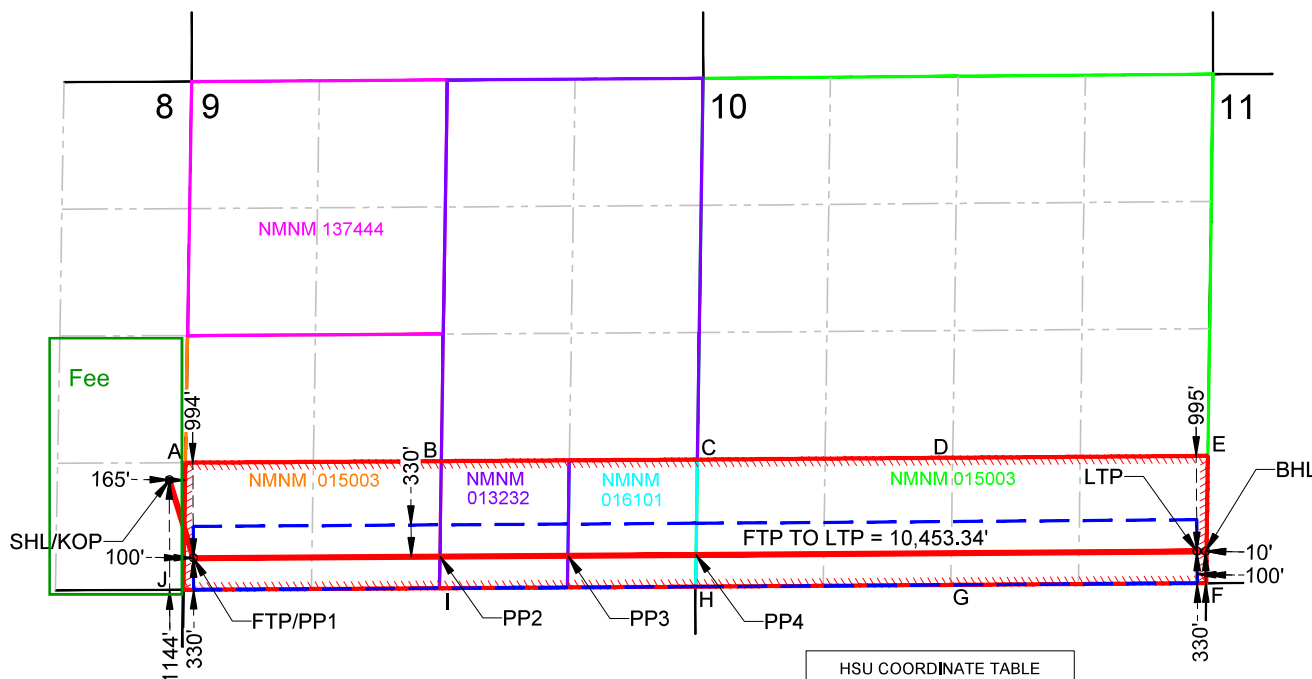

HSU COORDINATE TABLE		
POINT	N: (83)	E: (83)
A	576387.83	585121.30
B	576404.22	587787.58
C	576420.62	590454.73
D	576439.82	593112.98
E	576459.03	595771.36
F	575134.28	595753.43
G	575115.45	593094.38
H	575097.10	590435.59
I	575080.69	587767.05
J	575063.99	585099.23

**SURFACE HOLE LOCATION (SHL)
KICK OFF POINT (KOP)**
NEW MEXICO EAST - NAD 83
X=584953.27 LAT.= 32.58397° N
Y=576207.24 LONG.= 104.19173° W
NEW MEXICO EAST - NAD 27
X=543773.08 LAT.= 32.58385° N
Y=576145.84 LONG.= 104.19122° W
1144' FSL, 165' FEL - SECTION 8

**FIRST TAKE POINT (FTP)
PENETRATION POINT 1 (PP1)**
NEW MEXICO EAST - NAD 83
X=585204.76 LAT.= 32.58173° N
Y=575394.66 LONG.= 104.19091° W
NEW MEXICO EAST - NAD 27
X=544024.55 LAT.= 32.58162° N
Y=575333.27 LONG.= 104.19041° W
330' FSL, 100' FWL - SECTION 9
330' FSL, 100' FWL - LEASE

PENETRATION POINT 2 (PP2)
NEW MEXICO EAST - NAD 83
X=587772.17 LAT.= 32.58177° N
Y=575410.59 LONG.= 104.18258° W
NEW MEXICO EAST - NAD 27
X=546591.95 LAT.= 32.58165° N
Y=575349.18 LONG.= 104.18207° W
330' FSL, 2667' FWL - SECTION 9
330' FSL, 0' FWL - LEASE

PENETRATION POINT 3 (PP3)
NEW MEXICO EAST - NAD 83
X=589106.31 LAT.= 32.58178° N
Y=575418.86 LONG.= 104.17825° W
NEW MEXICO EAST - NAD 27
X=547926.08 LAT.= 32.58167° N
Y=575357.44 LONG.= 104.17774° W
330' FSL, 1334' FEL - SECTION 9
330' FSL, 0' FEL - LEASE

PENETRATION POINT 4 (PP4)
NEW MEXICO EAST - NAD 83
X=590440.36 LAT.= 32.58180° N
Y=575427.14 LONG.= 104.17392° W
NEW MEXICO EAST - NAD 27
X=549260.14 LAT.= 32.58168° N
Y=575365.71 LONG.= 104.17341° W
330' FSL, 0' FEL - SECTION 9
330' FSL, 0' FEL - LEASE

LAST TAKE POINT (LTP)
NEW MEXICO EAST - NAD 83
X=595657.87 LAT.= 32.58188° N
Y=575463.61 LONG.= 104.15698° W
NEW MEXICO EAST - NAD 27
X=554477.63 LAT.= 32.58176° N
Y=575402.14 LONG.= 104.15647° W
330' FSL, 100' FEL - SECTION 10
330' FSL, 100' FEL - LEASE

BOTTOM HOLE LOCATION (BHL)
NEW MEXICO EAST - NAD 83
X=595747.89 LAT.= 32.58188° N
Y=575464.25 LONG.= 104.15668° W
NEW MEXICO EAST - NAD 27
X=554567.65 LAT.= 32.58176° N
Y=575402.77 LONG.= 104.15618° W
330' FSL, 10' FEL - SECTION 10
330' FSL, 10' FEL - LEASE

APD ID: 10400108077

Submission Date: 10/30/2025

Highlighted data reflects the most recent changes

Operator Name: PERMIAN RESOURCES OPERATING LLC

Well Name: KOALA 9 FED COM

Well Number: 124H

Well Type: CONVENTIONAL GAS WELL

Well Work Type: Drill

[Show Final Text](#)

Section 1 - Geologic Formations

Formation ID	Formation Name	Elevation	True Vertical	Measured Depth	Lithologies	Mineral Resources	Producing Formatio
17295966	QUATERNARY	3274	0	0	ALLUVIUM	USEABLE WATER	N
17295967	RUSTLER	3047	227	227	ANHYDRITE, SANDSTONE	USEABLE WATER	N
17295968	TOP OF SALT	2906	368	368	SALT	USEABLE WATER	N
17295985	TANSILL	2570	704	704	SANDSTONE	NATURAL GAS, OIL	N
17295986	YATES	2495	779	779	LIMESTONE, SANDSTONE, SHALE	NATURAL GAS, OIL	N
17295987	SEVEN RIVERS	2120	1154	1154	LIMESTONE, SANDSTONE, SHALE	NATURAL GAS, OIL	N
17295988	QUEEN	1450	1824	1824	LIMESTONE, SANDSTONE, SHALE	NATURAL GAS, OIL	N
17295989	GRAYBURG	1220	2054	2054	LIMESTONE, SANDSTONE, SHALE	NATURAL GAS, OIL	N
17295973	SAN ANDRES	870	2404	2405	LIMESTONE, SANDSTONE, SHALE	NATURAL GAS, OIL	N
17295975	CAPITAN REEF	770	2504	2507	LIMESTONE, SANDSTONE, SHALE	NATURAL GAS, OIL	N
17295982	CHERRY CANYON	295	2979	2996	LIMESTONE, SANDSTONE, SHALE	NATURAL GAS, OIL	N
17295983	BELL CANYON	-80	3354	3384	LIMESTONE, SANDSTONE, SHALE	NATURAL GAS, OIL	N
17295984	BONE SPRING LIME	-1380	4654	4730	LIMESTONE, SANDSTONE, SHALE	NATURAL GAS, OIL	N
17295990	BONE SPRING 1ST	-2830	6104	6206	LIMESTONE, SANDSTONE, SHALE	NATURAL GAS, OIL	N
17295991	BONE SPRING 2ND	-3880	7154	7281	LIMESTONE, SANDSTONE, SHALE	NATURAL GAS, OIL	Y

Section 2 - Blowout Prevention

Well Name: KOALA 9 FED COM

Well Number: 124H

Pressure Rating (PSI): 5M

Rating Depth: 7329

Equipment: BOPE will meet all requirements for above listed system per 43 CFR 3172. BOPE with working pressure ratings in excess of anticipated maximum surface pressure will be utilized for well control from drill out of surface casing to TMD. The system may be upgraded to a higher pressure but still tested to the working pressure listed in the table above. If the system is upgraded all of the components installed will be functional, tested, and will meet all requirements per 43 CFR 3172. The wellhead will be a multibowl speed head allowing for hangoff of intermediate casing of the surface x intermediate annulus without breaking the connection between the BOP & wellhead. A variance is requested to utilize a flexible choke line (flexhose) from the BOP to choke manifold.

Requesting Variance? YES

Variance request: Multibowl Wellhead, Flexhose, Breaktesting, Offline Cementing Variances. Attachments in Section 8.

Testing Procedure: Operator requests to ONLY test broken pressure seals per API Standard 53 and the attachments in Section 8. The BOP test shall be performed before drilling out of the surface casing shoe and will occur at a minimum: a. when initially installed, b. whenever any seal subject to test pressure is broken, c. following related repairs, d. at 21-day intervals. Testing of the ram type preventer(s) and annual type preventer(s) shall be tested per 43 CFR 3172. The BOPE configuration, choke manifold layout, and accumulator system will be in compliance with 43 CFR 3172. Bleed lines will discharge 100' from wellhead in non-H2S scenarios and 150' from wellhead in H2S scenarios.

Choke Diagram Attachment:

Koala_9_Fed_Com_5MCM_20251029110352.pdf

BOP Diagram Attachment:

Koala_9_Fed_Com_5M_BOP_20251029110357.pdf

Section 3 - Casing

Casing ID	String Type	Hole Size	Csg Size	Condition	Standard	Tapered String	Top Set MD	Bottom Set MD	Top Set TVD	Bottom Set TVD	Top Set MSL	Bottom Set MSL	Calculated casing length MD	Grade	Weight	Joint Type	Collapse SF	Burst SF	Joint SF Type	Joint SF	Body SF Type	Body SF
1	SURFACE	17.5	13.375	NEW	API	N	0	252	0	252	3274	3022	252	J-55	54.5	BUTT	9.08	3.25	DRY	7.99	DRY	7.5
2	INTERMEDIATE	12.25	9.625	NEW	API	N	0	3029	0	3029	3700	245	3029	J-55	36	BUTT	3.12	1.71	DRY	3.06	DRY	2.7
3	PRODUCTION	8.5	5.5	NEW	NON API	N	0	17819	0	7329	3671	-4055	17819	P-110	17	OTHER - Bushmaster SP	1.96	2.05	DRY	2.43	DRY	2.43

Casing Attachments

Well Name: KOALA 9 FED COM

Well Number: 124H

Casing Attachments

Casing ID: 1 **String** SURFACE

Inspection Document:

Spec Document:

Tapered String Spec:

Casing Design Assumptions and Worksheet(s):

Koala_9_Fed_Com_124H_CSG_20251029144528.pdf

Casing ID: 2 **String** INTERMEDIATE

Inspection Document:

Spec Document:

Tapered String Spec:

Casing Design Assumptions and Worksheet(s):

Koala_9_Fed_Com_124H_CSG_20251029144459.pdf

Casing ID: 3 **String** PRODUCTION

Inspection Document:

Spec Document:

Koala_9_Fed_Com_Prod_Csg_Spec_Sheet_20251029110732.pdf

Tapered String Spec:

Casing Design Assumptions and Worksheet(s):

Koala_9_Fed_Com_124H_CSG_20251029144447.pdf

Section 4 - Cement

Well Name: KOALA 9 FED COM

Well Number: 124H

String Type	Lead/Tail	Stage Tool Depth	Top MD	Bottom MD	Quantity(sx)	Yield	Density	Cu Ft	Excess%	Cement type	Additives
SURFACE	Lead		0	252	210	1.34	14.8	270	50	Class C	Accelerator

INTERMEDIATE	Lead		0	2420	560	2.08	14.8	290	50	Class C	Salt, Extender, LCM
INTERMEDIATE	Tail		2420	3029	220	1.34	14.8	290	50	Class C	Accelerator
PRODUCTION	Lead		2529	6953	660	2.41	11.5	1580	40	Class H	POZ, Extender, Fluid Loss, Dispersant, Retarder
PRODUCTION	Tail		6953	17819	1820	1.73	12.5	3140	25	Class H	POZ, Extender, Fluid Loss, Dispersant, Retarder

Section 5 - Circulating Medium

Mud System Type: Closed

Will an air or gas system be Used? NO

Description of the equipment for the circulating system in accordance with 43 CFR 3172:

Diagram of the equipment for the circulating system in accordance with 43 CFR 3172:

Describe what will be on location to control well or mitigate other conditions: Sufficient quantities of mud materials will be on the well site at all times for the purpose of assuring well control and maintaining wellbore integrity. Surface interval will employ fresh water mud. The intermediate hole will utilize a saturated brine fluid to inhibit salt washout. The production hole will employ brine based and oil base fluid to inhibit formation reactivity and of the appropriate density to maintain well control.

Describe the mud monitoring system utilized: Centrifuge separation system. Open tank monitoring with EDR will be used for drilling fluids and return volumes. Open tank monitoring will be used for cement and cuttings return volumes. Mud properties will be monitored at least every 24 hours using industry accepted mud check practices.

Circulating Medium Table

Top Depth	Bottom Depth	Mud Type	Min Weight (lbs/gal)	Max Weight (lbs/gal)	Density (lbs/cu ft)	Gel Strength (lbs/100 sqft)	PH	Viscosity (CP)	Salinity (ppm)	Filtration (cc)	Additional Characteristics
252	3029	SALT SATURATED	10	10							

Well Name: KOALA 9 FED COM

Well Number: 124H

Top Depth	Bottom Depth	Mud Type	Min Weight (lbs/gal)	Max Weight (lbs/gal)	Density (lbs/cu ft)	Gel Strength (lbs/100 sqft)	PH	Viscosity (CP)	Salinity (ppm)	Filtration (cc)	Additional Characteristics
3029	1903 8	OTHER : OBM / Brine	9	10							
0	252	SPUD MUD	8.6	9.5							

Section 6 - Test, Logging, Coring

List of production tests including testing procedures, equipment and safety measures:

Will utilize MWD/LWD from intermediate hole to TD of the well.

List of open and cased hole logs run in the well:

DIRECTIONAL SURVEY,

Coring operation description for the well:

No Coring is Planned

Section 7 - Pressure

Anticipated Bottom Hole Pressure: 3820

Anticipated Surface Pressure: 2207

Anticipated Bottom Hole Temperature(F): 131

Anticipated abnormal pressures, temperatures, or potential geologic hazards? NO

Describe:

Contingency Plans geohazards description:

Contingency Plans geohazards

Hydrogen Sulfide drilling operations plan required? YES

Hydrogen sulfide drilling operations

Koala_9_Fed_Com_North_Pad_H2S_20251029111841.pdf

Koala_9_Fed_Com_South_Pad_H2S_20251029111841.pdf

Well Name: KOALA 9 FED COM

Well Number: 124H

Section 8 - Other Information

Proposed horizontal/directional/multi-lateral plan submission:

Koala_9_Fed_Com_124H_DD_20251029144645.pdf

Koala_9_Fed_Com_124H_AC_20251029144645.pdf

Other proposed operations facets description:

Other proposed operations facets attachment:

Koala_9_Fed_Com_NGMP_20251120121812.pdf

Other Variance request(s)?: Y

Other Variance attachment:

Koala_9_Fed_Com_Batch_20251029111807.pdf

Koala_9_Fed_Com_Break_20251029111807.pdf

Koala_9_Fed_Com_FH_20251029111807.pdf

Koala_9_Fed_Com_MBS_20251029111807.pdf

Koala_9_Fed_Com_OLCV_20251029111808.pdf

Bleed lines will discharge 100' from WH in non-H2S scenarios and 150' from WH in H2S scenarios.

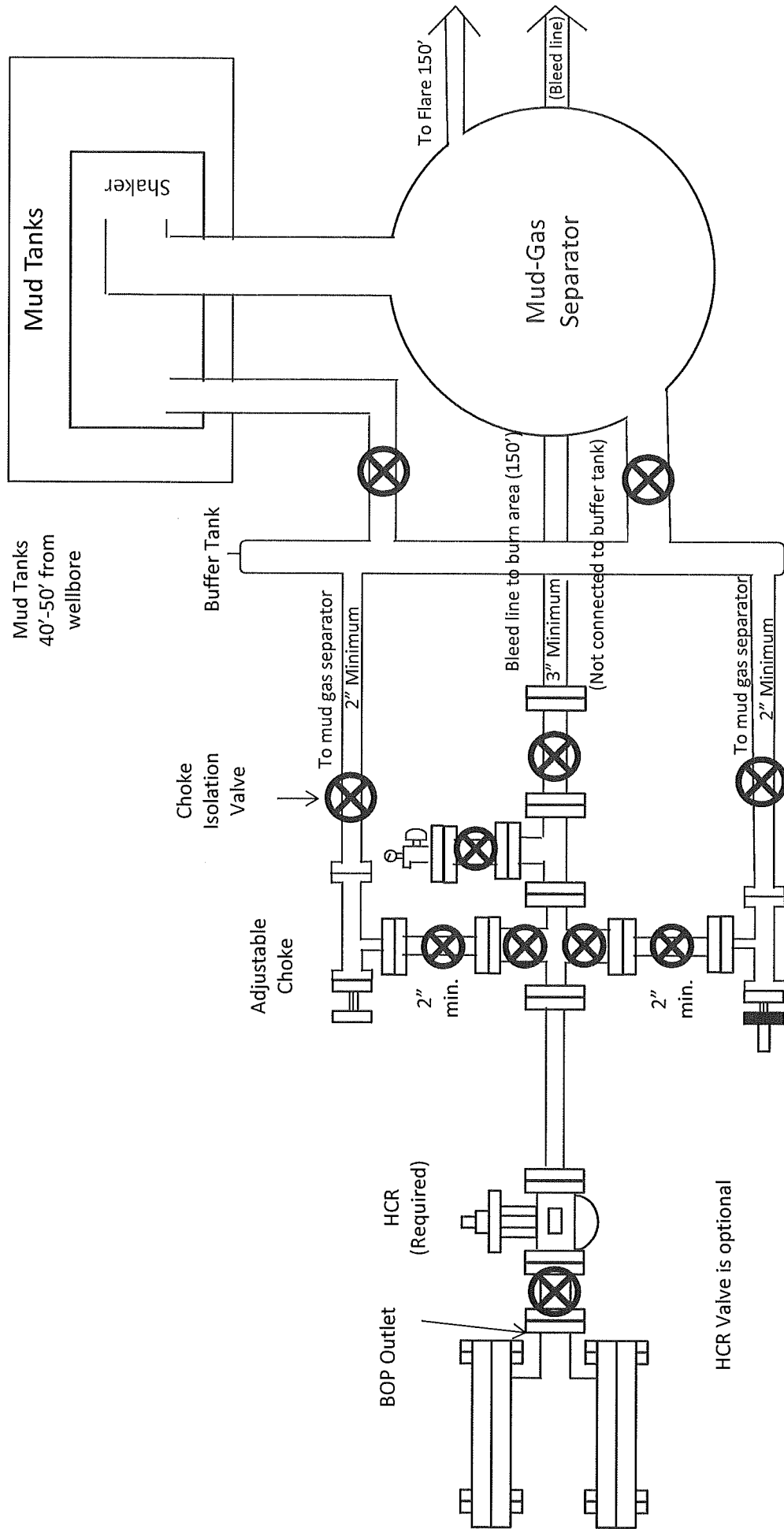

5M Choke Manifold Diagram
Permian Resources Operating, LLC

Drilling Operations Choke Manifold 5M Service

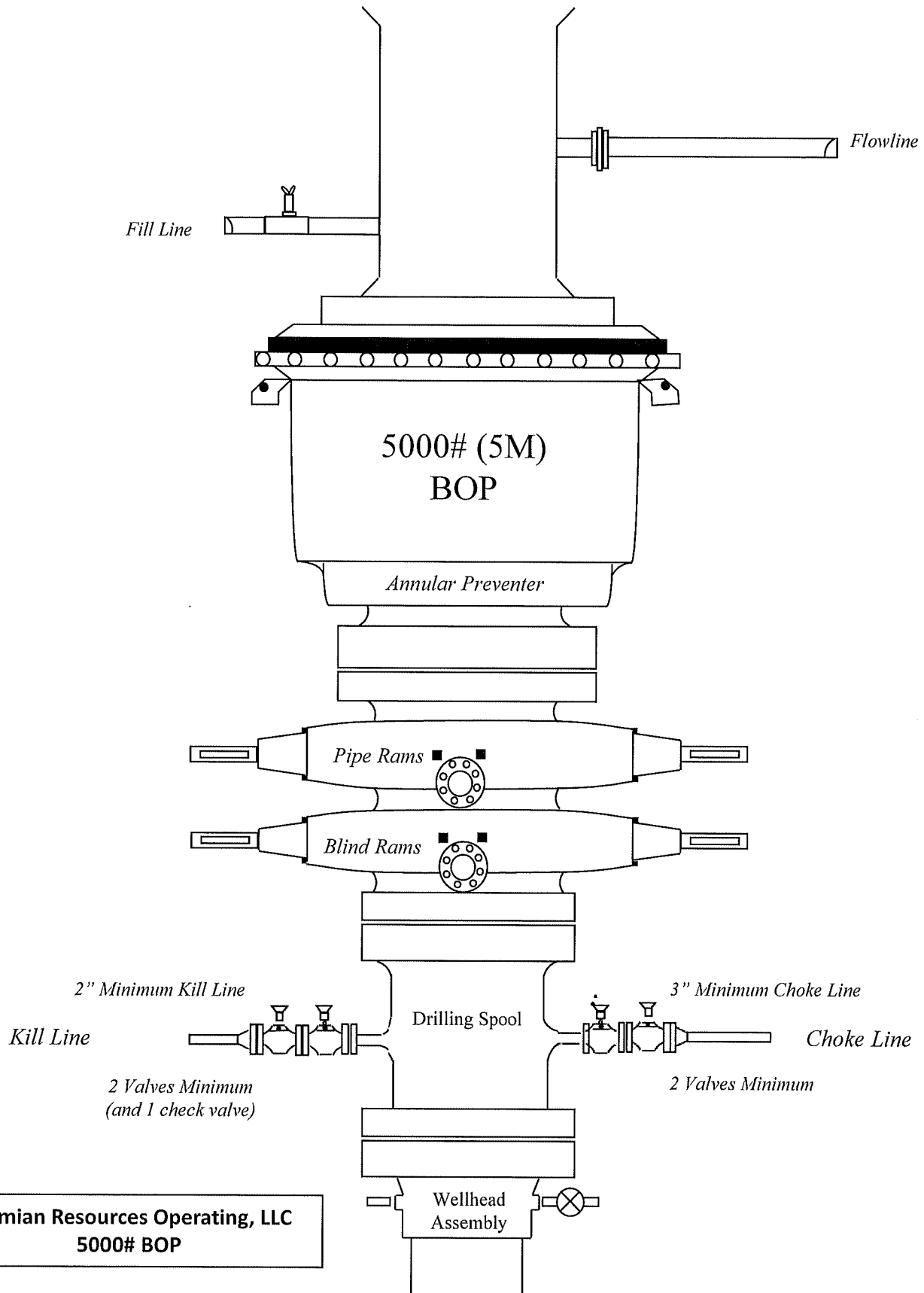

Bleed lines will discharge 100' from WH in non-H2S scenarios and 150' from WH in H2S scenarios.



Connection Data Sheet

Issued on: May. 09, 2025

5.500" 17.00# P-110 RY (SeAH) Bushmaster® SP SC6.050

Pipe Body Data	
Nominal OD	5.500 in.
Wall Thickness	0.304 in.
Weight	17.00 lb/ft
PE Weight	16.89 lb/ft
Nominal ID	4.892 in.
Drift	4.767 in.
Minimum Yield Strength	110,000 psi
Minimum Tensile Strength	125,000 psi
Remaining Body Wall (RBW)	95.0% Rating

Connection Data	
Connection OD	6.050 in.
Connection ID	4.892 in.
Make-Up Loss	4.209 in.
Tension Efficiency	100.0% Rating
Compression Efficiency	100.0% Rating
Yield Strength in Tension	546,000 lbs
Yield Strength in Compression	546,000 lbs
MIYP (Burst)	11,550 psi
Collapse	7,480 psi
Uniaxial Bending	91.7 °/100ft.

Make-up Torque		
Max. Operating Torque	-	37,300 ft. lbs
Maximum Make-up	-	17,900 ft. lbs
Optimum Make-Up	-	16,300 ft. lbs
Minimum Make-Up	-	14,700 ft. lbs

Buck-on Torque		
Maximum Make-Up	-	19,900 ft. lbs
Optimum Make-Up	-	18,100 ft. lbs
Minimum Make-Up	-	16,300 ft. lbs



For technical support please email support@fermata-tech.com or call (281) 941-5257.

This document is for general information only. It is not intended to be used or relied upon as a recommendation or professional advice for any specific application and is subject to change without notice. Anyone who uses this material does so at their own right and assumes any and all liability resulting from such use.

Connection performance values pertain to structural capacity.

3. Casing

String	Hole Size	Casing Size	Top	Bottom	Top TVD	Bottom TVD	Length	Grade	Weight	Connection	Collapse SF	Burst SF	Joint SF Type	Joint SF	Body SF Type	Body SF
Surface	17.5	13.375	0	252	0	252	252	J55	54.5	BTC	9.08	3.25	Dry	7.99	Dry	7.50
Intermediate	12.25	9.625	0	3029	0	3029	3029	J55	36	BTC	3.12	1.71	Dry	3.06	Dry	2.70
Production	8.75	5.5	0	7703	0	7329	7703	P110RY	17	Bushmast	1.96	2.05	Dry	2.43	Dry	2.43
Production	8.5	5.5	7703	17819	7329	7329	10116	P110RY	17	Bushmast	1.96	2.05	Dry	2.43	Dry	2.43
BLM Min Safety Factor											1.125	1		1.6		1.6

Non API casing spec sheets and casing design assumptions attached.

PERMIAN

R E S O U R C E S

H₂S CONTINGENCY PLAN

FOR

Permian Resources Corporation

**Koala 9 Fed Com 204H, 203H, 133H, 134H, 123H, 124H, 113H,
114H**

Eddy County, New Mexico

10-28-2025

This plan is subject to updating

Permian Resources Corporation	H ₂ S Contingency Plan Koala 9 South Pad	Eddy County, New Mexico
-------------------------------	--	-------------------------

Table of Contents

- Section 1.0 – Introduction 3**
 - I. Purpose
 - II. Scope & Applicability
- Section 2.0 - Plan Implementation.....3**
 - I. Activation Requirements
 - II. Emergency Evacuation
 - III. Emergency Response Activities
- Section 3.0 - Potential Hazardous Conditions.....4**
- Section 4.0 - Notification of H₂S Release Event.....6**
 - I. Local & State Law Enforcement
 - II. General Public
 - III. New Mexico Oil Conservation Division
 - IV. New Mexico Environment Department
 - V. Bureau of Land Management
- Section 5.0 - Emergency Contact List.....7**
 - I. Permian Resources Management Personnel
 - II. Eddy County Sheriff
 - III. New Mexico State Highway Patrol
 - IV. Fire / EMS
 - V. Carlsbad Memorial Hospital
 - VI. Emergency Response Contractors
 - VII. New Mexico Oil Conservation Division
 - VIII. New Mexico Environment Department
 - IX. Bureau of Land Management
 - X. Other Agencies
- Section 6.0 – Drilling Location Information.....9-12**
 - I. Site Safety Information
 - II. Directions to Location
 - III. Plat of Location including GPS Coordinates
 - IV. Routes of Ingress & Egress (MAP)
 - V. ROE Map
 - VI. Residences in ROE
 - VII. Public Roads in ROE
- Section 7.0 – Hazard Communication.....13-15**
 - I. Physical Characteristics of Hydrogen Sulfide Gas
 - II. Human Health Hazards / Toxicological Information
 - III. Environmental Hazards
- Section 8.0 - Regulatory Information.....15-17**
 - I. OSHA Information
 - II. New Mexico Oil Conservation Division & Bureau of Land Management
- Section 9.0 - Training Requirements.....17**
- Section 10.0 - Personal Protective Equipment.....18**
- Appendices**
 - I. Appendix A – H₂S SDS
 - II. Appendix B – SO₂ SDS

Permian Resources Corporation	H ₂ S Contingency Plan Koala 9 South Pad	Eddy County, New Mexico
-------------------------------	--	-------------------------

Section 1.0 – Introduction

I. Purpose

The purpose of this contingency plan (Plan) is to provide Permian Resources Corporation. (Permian Resources) with an organized plan of action for alerting and protecting Permian Resources employees, the general public, and any potential first responders prior to any intentional release or immediately following the accidental / unintentional release of a potentially hazardous volume / concentration of Hydrogen Sulfide Gas (H₂S).

II. Scope & Applicability

This Plan applies to all planned, unplanned, uncontrolled and/or unauthorized releases of hazardous concentrations of H₂S or any associated hazardous byproducts of combustion, occurring at any Permian Resources owned or operated facilities including but not limited to: wells, flowlines, pipelines, tank batteries, production facilities, SWD facilities, compressor stations, gas processing plants, drilling / completions / workover operations, and any other applicable company owned property.

Section 2.0 - Plan Implementation

I. Activation Requirements

In accordance with the requirements of Bureau of Land Management Onshore Order #6 and NMAC 19.15.11, this Plan shall be activated in advance of any authorized, planned, unplanned, uncontrolled, or unauthorized release of a hazardous volume / concentration of H₂S gas, or SO₂, which could potentially adversely impact the workers, general public or the environment.

II. Emergency Evacuation

In the event of an unplanned, uncontrolled, or unauthorized release of a hazardous volume / concentration of H₂S gas, the first priority is to ensure the safety of the workers and general public. Upon discovery and subsequent determination of an applicable release, which cannot be quickly mitigated, immediately by using 911, notify local authorities to begin the process of alerting the general public, evacuate any residents within the Radius of Exposure (ROE), and limit any general public or employee access to any areas within the ROE of the affected facility.

III. Emergency Response Activities

The purpose of emergency response actions is to take steps to quickly mitigate / stop the ongoing release of the hazardous source of H₂S. Upon discovery of any hazardous release, immediately notify Permian Resources management to activate the Emergency Response Team (ERT). Once Permian Resources supervision arrives and assesses the situation, a work plan identifying the proper procedures shall be developed to stop the release.

Section 3.0 - Potential Hazardous Conditions & Response Actions

During a planned or unplanned release of H₂S, there are several hazardous conditions that are presented both to employees, the general public, and emergency responders. These specific hazardous conditions are identified in the tables below.

Permian Resources Corporation	H ₂ S Contingency Plan Koala 9 South Pad	Eddy County, New Mexico
-------------------------------	--	-------------------------

H2S OPERATING CONDITIONS – RESPONSE ACTIONS TO CONSIDER		✓
H₂S CONDITION 1: POTENTIAL DANGER TO LIFE AND HEALTH → WARNING SIGN GREEN		
H ₂ S concentration <10 ppm detected by location monitors		<input type="checkbox"/>
General Actions During Condition 1		<input type="checkbox"/>
Notify Site Supervisor / Permian Resources Person-in-Charge (PIC) of any observed increase in ambient H ₂ S concentrations		<input type="checkbox"/>
All personnel check safety equipment is in adequate working order & store in accessible location		<input type="checkbox"/>
Sensitize crews with safety meetings.		<input type="checkbox"/>
Limit visitors and non-essential personnel on location		<input type="checkbox"/>
Continuously monitor H ₂ S concentrations and check calibration of sensors		<input type="checkbox"/>
Ensure H ₂ S scavenger is on location.		<input type="checkbox"/>
H₂S CONDITION 2: MODERATE DANGER TO LIFE AND HEALTH → WARNING SIGN YELLOW		
H ₂ S concentration >10 ppm and < 30 ppm in atmosphere detected by location monitors:		<input type="checkbox"/>
General Actions During Condition 2		<input type="checkbox"/>
Sound H ₂ S alarm and/or display yellow flag.		<input type="checkbox"/>
Account for on-site personnel		<input type="checkbox"/>
Upon sounding of an area or personal H ₂ S monitor alarm when 10 ppm is reached, proceed to a safe briefing area upwind of the location immediately (see MA-4, Figure 5-1).		<input type="checkbox"/>
Don proper respiratory protection.		<input type="checkbox"/>
Alert other affected personnel		<input type="checkbox"/>
If trained and safe to do so undertake measures to control source H ₂ S discharge and eliminate possible ignition sources. Initiate Emergency Shutdown procedures as deemed necessary to correct or control the specific situation.		<input type="checkbox"/>
Account for on-site personnel at safe briefing area.		<input type="checkbox"/>
Stay in safe briefing area if not working to correct the situation.		<input type="checkbox"/>
Keep Site Supervisor / Permian Resources PIC informed. Notify applicable government agencies (Appendix A) If off-site impact; notify any neighbors within Radius of Exposure (ROE), Fig 5.11		<input type="checkbox"/>
Continuously monitor H ₂ S until readings below 10 ppm.		<input type="checkbox"/>
Evacuated area shall not be re-entered except by trained and authorized personnel utilizing appropriate respiratory protection; or until “all clear” sounded by Permian Resources PIC / Site Supervisor.		
H₂S CONDITION 3: EXTREME DANGER TO LIFE AND HEALTH → WARNING SIGN RED		
> 30 ppm H ₂ S concentration in air detected by location monitors: Extreme danger to life		
General Actions During Condition 3		
Sound H ₂ S alarm and/or display red flag.		<input type="checkbox"/>
Account for on-site personnel		<input type="checkbox"/>

Permian Resources Corporation	H ₂ S Contingency Plan Koala 9 South Pad	Eddy County, New Mexico
-------------------------------	--	-------------------------

Move away from H ₂ S source and get out of the affected area.	<input type="checkbox"/>
Proceed to designated safe briefing area; alert other affected personnel.	<input type="checkbox"/>
Account for personnel at safe briefing area.	<input type="checkbox"/>
If trained and safe to do so undertake measures to control source H ₂ S discharge and eliminate possible ignition sources. Initiate Emergency Shutdown procedures as deemed necessary to correct or control the specific situation.	<input type="checkbox"/>
Notify vehicles or situation and divert all traffic away from location.	<input type="checkbox"/>
Permian Resources Person-in-Charge will make appropriate community notifications.	<input type="checkbox"/>
Red warning flag must be on display until the situation has been corrected and the Permian Resources Person-in-Charge determines it is safe to resume operations under Condition 1 .	<input type="checkbox"/>
Notify management of the condition and action taken. If H ₂ S concentration is increasing and steps to correct the situation are not successful – or at any time if well control is questionable – alert all responsible parties for possible activation of the H ₂ S Contingency Plan. If well control at the surface is lost, determine if situation warrants igniting the well.	<input type="checkbox"/>
If uncontrolled flow at the surface occurs, the Permian Resources PIC, with approval, if possible, from those coordinating the emergency (as specified in the site-specific H₂S Contingency Plan) are responsible for determining if the situation warrants igniting the flow of the uncontrolled well. This decision should be made only as a last resort and in a situation where it is obvious that human life is in danger and there is no hope of controlling the flow under prevailing conditions.	<input type="checkbox"/>
If the flow is ignited, burning H ₂ S will be converted to sulfur dioxide (SO ₂), which is also highly toxic. Do not assume that area is safe after the flow is ignited. If the well is ignited, evacuation of the area is mandatory, because SO ₂ will remain in low-lying places under no-wind conditions.	<input type="checkbox"/>
Keep Site Supervisor / Permian Resources PIC informed. Notify applicable government agencies and local law enforcement (Appendix A) If off-site impact; notify any neighbors within the Radius of Exposure (ROE), see example in Figure 5-11 .	<input type="checkbox"/>
Continuously monitor H ₂ S until readings fall below 10 ppm.	<input type="checkbox"/>
Evacuated area shall not be re-entered except by trained and authorized personnel utilizing appropriate respiratory protection; or until “all clear” sounded by Permian Resources PIC / Site Supervisor.	<input type="checkbox"/>
IF ABOVE ACTIONS CANNOT BE ACCOMPLISHED IN TIME TO PREVENT EXPOSURE TO THE PUBLIC	<input type="checkbox"/>
Alert public (directly or through appropriate government agencies) who may be subject to potentially harmful exposure levels.	<input type="checkbox"/>
Make recommendations to public officials regarding blocking unauthorized access to the unsafe area and assist as appropriate.	<input type="checkbox"/>
Make recommendations to public officials regarding evacuating the public and assist as appropriate.	<input type="checkbox"/>
Monitor ambient air in the area of exposure (after following abatement measures) to determine when it is safe for re-entry.	<input type="checkbox"/>
	<input type="checkbox"/>

Permian Resources Corporation	H ₂ S Contingency Plan Koala 9 South Pad	Eddy County, New Mexico
-------------------------------	--	-------------------------

□

Section 4.0 - Notification of H₂S Release Event

I. Local & State Law Enforcement

Prior to the planned / controlled release of a hazardous concentration of H₂S gas or any associated byproducts of the combustion of H₂S gas, notify local law enforcement agencies regarding the contents of this plan.

In the event of the discovery of an unplanned/uncontrolled release of a hazardous concentration of H₂S gas or any associated byproducts of combustion, immediately notify local and/or state law enforcement agencies of the situation and ask for their assistance.

II. General Public

In the event of a planned or unplanned release of a hazardous concentration of H₂S gas or any associated byproducts of combustion, notify local law enforcement agencies and ask for their assistance in alerting the general public and limiting access to any public roads that may be impacted by such a release.

III. New Mexico Oil Conservation Division

The Permian Resources HSE Department will make any applicable notification to the New Mexico OCD regarding any release of a hazardous concentration of H₂S Gas or any associated byproducts of combustion.

IV. New Mexico Environment Department

The Permian Resources HSE Department will make any applicable notifications to the NMED regarding any release of a hazardous concentration of H₂S gas or any associated byproducts of combustion.

V. Bureau of Land Management

The Permian Resources Regulatory Department will make any applicable notifications to the BLM regarding any release of a hazardous concentration of H₂S gas or any associated byproducts of combustion.

Permian Resources Corporation	H ₂ S Contingency Plan Koala 9 South Pad	Eddy County, New Mexico
-------------------------------	--	-------------------------

Section 5.0 - Emergency Contact List

EMERGENCY CONTACT LIST				
PERMIAN RESOURCES CORPORATION.				
POSITION	NAME	OFFICE	CELL	ALT PHONE
Operations				
Operations Superintendent	Rick Lawson		432.530.3188	
TX Operations Superintendent	Josh Graham	432.940.3191	432.940.3191	
NM Operations Superintendent	Manual Mata	432.664.0278	575.408.0216	
Drilling Manager	Jason Fitzgerald	432.315.0146	318.347.3916	
Drilling Engineer	Parker Simmons	432.400.1038	281.536.9813	
Production Manager	Levi Harris	432.219.8568	720.261.4633	
SVP Development Ops	Clayton Smith	720.499.1416	361.215.2494	
SVP Production Ops	Casey McCain	432.695.4239	432.664.6140	
HSE & Regulatory				
H&S Manager	Adam Hicks		903.426.4556	
Regulatory Manager	Stephanie Rabadue		432.260.4388	
Environmental Manager	Montgomery Floyd	432-315-0123	432-425-8321	
HSE Consultant	Blake Wisdom		918-323-2343	
Local, State, & Federal Agencies				
Eddy County Sheriff		575-887-7551		911
New Mexico State Highway Patrol		505-757-2297		911
Carlsbad Fire / EMS		575-885-3125		911
Carlsbad Memorial Hospital		575-887-4100		
Secorp – Safety Contractor	Ricky Stephens		(325)-262-0707	
New Mexico Oil Conservation Division – District 1 Office – Hobbs, NM.		575-393-6161		
New Mexico Environment Department – District III Office – Hobbs, NM		575-397-6910		
New Mexico Oil Conservation Division – Hobbs, NM	24 Hour Emergency	575-393-6161		
Bureau of Land Management – Carlsbad, NM		575-706-2779		
Eddy County PET Inspector		575-361-2822		
U.S. Fish & Wildlife		502-248-6911		

Section 6.0 – Drilling Location Information**I. Site Safety Information****1. Safe Briefing Area**

- a. There shall be two areas that will be designated as "SAFE BRIEFING AREAS". If H₂S is detected in concentrations equal to or in excess of 10 ppm all personnel not assigned emergency duties are to assemble in the designated Safe Briefing area for instructions. These two areas shall be positioned in accessible locations to facilitate the availability of self-contained breathing air devices. The briefing areas shall be positioned no less than 250' from the wellhead and in such locations that at least one briefing area will be up-wind from the well at all times.

Permian Resources Corporation	H ₂ S Contingency Plan Koala 9 South Pad	Eddy County, New Mexico
-------------------------------	--	-------------------------

2. Wind Indicators
 - a. 4 Windsocks will be installed at strategic points on the facility.
3. Danger Signs
 - a. A warning sign indicating the possible well conditions will be displayed at the location entrance.

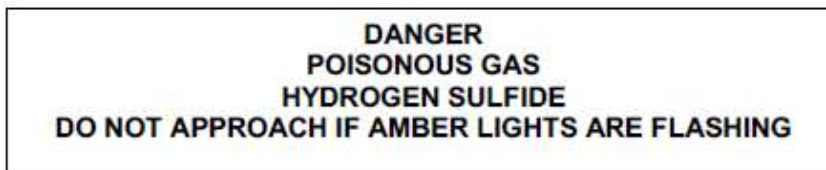

4. H₂S Detectors and Alarms
 - a. Continuous monitoring type H₂S detectors, capable of sensing a minimum of 5ppm H₂S in air will be located centrally located at the tanks, heater treater, and combustor. Continuous monitoring type SO₂ detector will also be located at the combustor. The automatic H₂S alarm/flashing light will be located at the site entrance and in front of tank battery.
5. Safety Trailer
 - a. A safety trailer equipped with an emergency cascade breathing air system with 2 ea. Work/escape packs, a stretcher, 2 OSHA approved full body harnesses, and a 20# Class ABC fire extinguisher shall be available at the site in close proximity to the safe briefing area. The cascade system shall be able to be deployed to the drill floor when needed to provide safe breathing air to the workers as needed.
6. Well Control Equipment
 - a. The location shall have a flare line to a remote automatic ignitor and back up flare gun, placed 150' from the wellhead.
 - b. The location shall be equipped with a remotely operated choke system and a mud gas separator.
7. Mud Program
 - a. Company shall have a mud program that contains sufficient weight and additives to control H₂S.
8. Metallurgy
 - a. All drill strings, casing, tubing, wellhead, BOP, spools, kill lines, choke manifold and lines, and valves shall be suitable for anticipated H₂S volume and pressure.
9. Communication
 - a. The location shall be equipped with a means of effective communication such as a cell phones, intercoms, satellite phones or landlines.

Permian Resources Corporation	H ₂ S Contingency Plan Koala 9 South Pad	Eddy County, New Mexico
-------------------------------	--	-------------------------

II. Directions to Location

STARTING AT THE INTERSECTION OF CR 206 (ILLINOIS CAMP RD) AND GEORGE SHOUP RELEIF ROUTE, PROCEED NORTH ON CR 206 FOR APPROX. 8.1 MILES.

TURN RIGHT ON ANGEL RANCH RD AND CONTINUE EAST 1.83 MILES

TURN LEFT ON ACCESS ROAD AND CONTINUE EAST 0.20 MILES

Permian Resources Corporation	H ₂ S Contingency Plan Koala 9 South Pad	Eddy County, New Mexico
-------------------------------	--	-------------------------

1. Routes of Ingress & Egress (MAP)

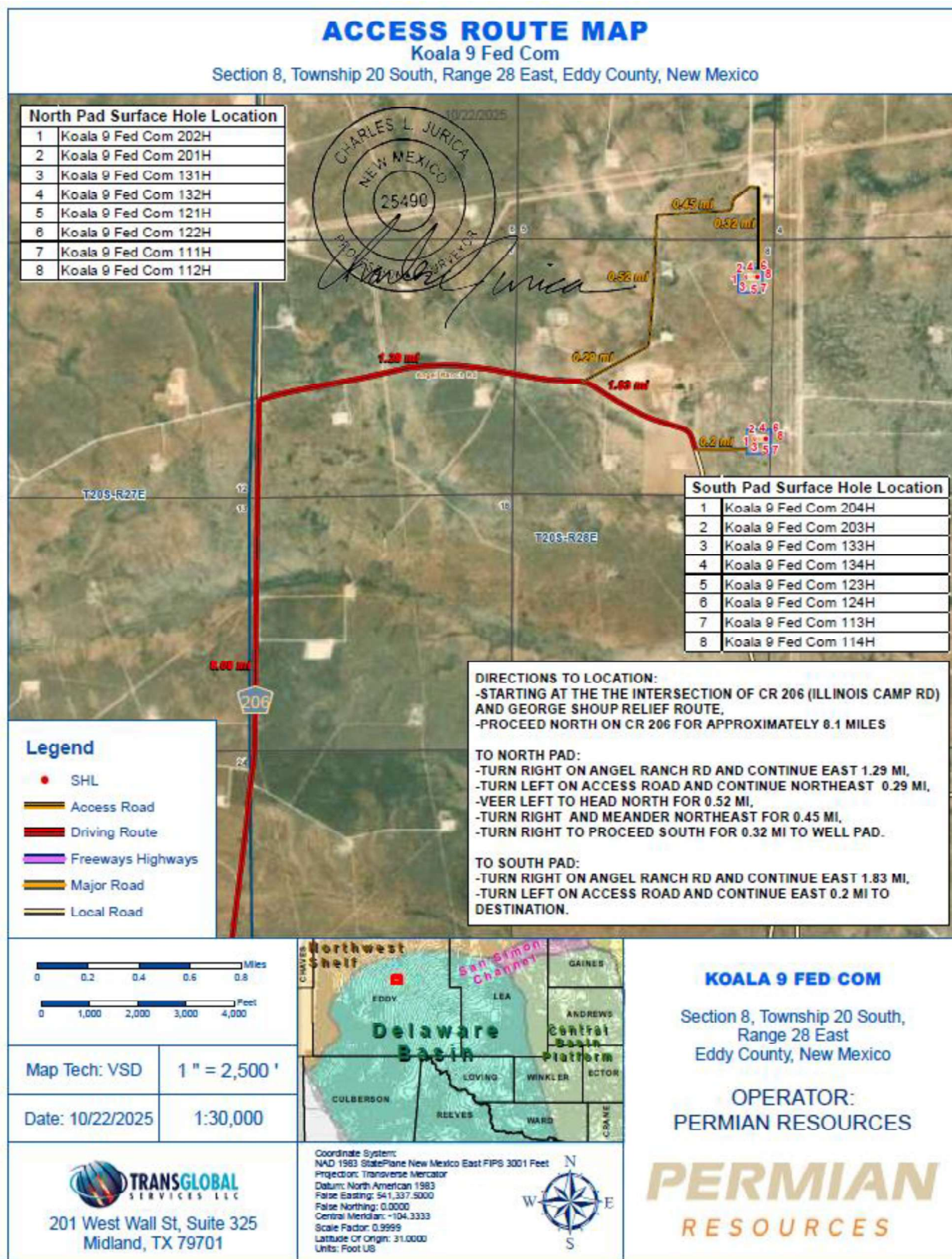

2. Residences in proximity to the 3000' Radius of Exposure (ROE) (MAP)

There are no residences or public gathering places with the 100 PPM, 300 PPM, or 500 PPM ROE.

Permian Resources Corporation	H ₂ S Contingency Plan Koala 9 South Pad	Eddy County, New Mexico
-------------------------------	--	-------------------------

Map of 3000' ROE Perimeter



100 PPM, 300 PPM, & 500 PPM Max ROE under worst case scenario

Enter H ₂ S in PPM	<input type="text" value="1500"/>
Enter Gas flow in mcf/day (maximum worst case conditions)	<input type="text" value="2500"/>
500 ppm radius of exposure (public road)	<u>105</u> feet
300 ppm radius of exposure	<u>146</u> feet
100 ppm radius of exposure (public area)	<u>230</u> feet

- Location NAD 83 GPS Coordinates **Lat: 32.58377483, Long: -104.19200721**

3. Public Roads in proximity of the Radius of Exposure (ROE)

There are no public roads that would be within the 500 PPM ROE. The closest public road is Angel Ranch Rd, which is approx. 1,250' from the location.

Permian Resources Corporation	H ₂ S Contingency Plan Koala 9 South Pad	Eddy County, New Mexico
-------------------------------	--	-------------------------

Section 7.0 – Hazard Communication

I. Physical Characteristics of Hydrogen Sulfide Gas

Hydrogen sulfide (H₂S) is a colorless, poisonous gas that is soluble in water. It can be present in crude oils, condensates, natural gas and wastewater streams.

H₂S is heavier than air with a vapor density of 1.189 (air = 1.0); however, H₂S is most often mixed with other gases. These mixtures of H₂S and other gases can be heavier or lighter than air. If the H₂S-containing mixture is heavier, it can collect in low areas such as ditches, ravines, firewalls, and pits; in storage tanks; and in areas of poor ventilation. Please see physical properties in **Table 7.0**.

With H₂S the sense of smell is rapidly lost allowing lethal concentrations to be accumulated without warning. The toxicity of hydrogen sulfide at varying concentrations is indicated in the **Table 7.1**.

Warning: Do not use the mouth-to-mouth method if a victim ingested or inhaled hydrogen sulfide. Give artificial respiration with the aid of a pocket mask equipped with a one-way valve or other proper respiratory medical device.

Table 7.0. Physical Properties of H₂S

Properties of H ₂ S	Description
Vapor Density > 1 = 1.189 Air = 1	<ul style="list-style-type: none"> ▪ H₂S gas is slightly heavier than air, which can cause it to settle in low places and build in concentration. ▪ Produced as a mixture with other gases associated with oil and gas production.
Flammable Range 4.3%-46% 43000 ppm – 460000 ppm	<ul style="list-style-type: none"> ▪ H₂S can be extremely flammable / explosive when these concentrations are reached by volume in air.

Although H₂S is primarily a respiratory hazard, it is also flammable and forms an explosive mixture at concentrations of 4.3%–46.0% (40,000ppm – 460,000 ppm) by volume in air.

H₂S can be encountered when:

- Venting and draining equipment.
- Opening equipment (separators, pumps, and tanks).
- Opening piping connections (“line breaking”).
- Gauging and sampling storage tanks.
- Entering confined spaces.
- Working around wastewater pits, skimmers, and treatment facilities.

II. Human Health Hazards - Toxicological Information

Permian Resources Corporation	H ₂ S Contingency Plan Koala 9 South Pad	Eddy County, New Mexico
-------------------------------	--	-------------------------

Table 7.1. Hazards & Toxicity

Concentration (ppm)	Symptoms/Effects
0.00011-0.00033 ppm	Typical background concentrations
0.01-1.5 ppm	Odor threshold (when rotten egg smell is first noticeable to some). Odor becomes more offensive at 3-5 ppm. Above 30 ppm, odor described as sweet or sickeningly sweet.
2-5 ppm	Prolonged exposure may cause nausea, tearing of the eyes, headaches or loss of sleep. Airway problems (bronchial constriction) in some asthma patients.
20 ppm	Possible fatigue, loss of appetite, headache, irritability, poor memory, dizziness.
50-100 ppm	Slight conjunctivitis ("gas eye") and respiratory tract irritation after 1 hour. May cause digestive upset and loss of appetite.
100 ppm	Coughing, eye irritation, loss of smell after 2-15 minutes (olfactory fatigue). Altered breathing, drowsiness after 15-30 minutes. Throat irritation after 1 hour. Gradual increase in severity of symptoms over several hours. Death may occur after 48 hours.
100-150 ppm	Loss of smell (olfactory fatigue or paralysis).
200-300 ppm	Marked conjunctivitis and respiratory tract irritation after 1 hour. Pulmonary edema may occur from prolonged exposure.
500-700 ppm	Staggering, collapse in 5 minutes. Serious damage to the eyes in 30 minutes. Death after 30-60 minutes.
700-1000 ppm	Rapid unconsciousness, "knockdown" or immediate collapse within 1 to 2 breaths, breathing stops, death within minutes.
1000-2000 ppm	Nearly instant death

III. Environmental Hazards

H₂S and its associated byproducts from combustion presents a serious environmental hazard. Sulphur Dioxide SO₂ is produced as a constituent of flaring H₂S Gas and can present hazards associated, which are similar to H₂S. Although SO₂ is heavier than air, it will be picked up by a breeze and carried downwind at

Permian Resources Corporation	H ₂ S Contingency Plan Koala 9 South Pad	Eddy County, New Mexico
-------------------------------	--	-------------------------

elevated temperatures. Since Sulfur Dioxide is extremely irritating to the eyes and mucous membranes of the upper respiratory tract, it has exceptionally good warning powers in this respect. The following table indicates the toxic nature of the gas. Please see the attached SDS in Appendix B for reference.

SULFUR DIOXIDE TOXICITY		
Concentration		Effects
%SO ₂	PPM	
0.0005	3 to 5	Pungent odor-normally a person can detect SO ₂ in this range.
0.0012	12	Throat irritation, coughing, and constriction of the chest tearing and smarting of eyes.
0.15	150	So irritating that it can only be endured for a few minutes.
0.05	500	Causes a sense of suffocation, even with first breath.

Section 8.0 - Regulatory Information

I. OSHA & NIOSH Information

II. **Table 8.0. OSHA & NIOSH H₂S Information**

PEL, IDLH, TLV	Description
NIOSH PEL 10 PPM	<ul style="list-style-type: none"> PEL is the Permissible Exposure Limit that an employee may be exposed up to 8 hr / day.
OSHA General Industry Ceiling PEL – 20 PPM	<ul style="list-style-type: none"> The maximum exposure limit, which cannot be exceeded for any length of time.
IDLH 100 PPM	<ul style="list-style-type: none"> Immediately Dangerous to Life and Health
Permian Resources PEL 10 PPM	<ul style="list-style-type: none"> Permian Resources Policy Regarding H₂S for employee safety

III. New Mexico OCD & BLM – H₂S Concentration Threshold Requirements

New Mexico NMAC 19.15.11 and Onshore Order #6 identify two Radii of Exposure (ROE) that identify potential danger to the public and require additional compliance measures. Permian Resources is required to install safety devices, establish safety procedures and develop a written H₂S contingency plan for sites where the H₂S concentrations are as follows.

Table 8.1. Calculating H₂S Radius of Exposure

H ₂ S Radius of Exposure	Description	Control and Equipment Requirements
100 ppm	Distance from a release to where the H ₂ S concentration in the air will dilute below 100ppm	ROE > 50-ft and includes any part of a “public area” (residence, school, business, etc., or any area that can be expected to be populated). ROE > 3,000-ft

Permian Resources Corporation	H ₂ S Contingency Plan Koala 9 South Pad	Eddy County, New Mexico
-------------------------------	--	-------------------------

500 ppm	Distance from a release to where the H ₂ S concentration in the air will dilute below 500ppm	ROE > 50-ft and includes any part of a public road (public roads are tax supported roads or any road used for public access or use)
---------	---	---

Calculating H₂S Radius of Exposure

The ROE of an H₂S release is calculated to determine if a potentially hazardous volume of H₂S gas at 100 or 500 parts per million (ppm) is within a regulated distance requiring further action. If information about the concentration of H₂S and the potential gas release volume is known, the location of the Muster Areas will be set, and safety measures will be implemented based on the calculated radius of exposure (ROE). NMAC 19.15.11 – Hydrogen Sulfide Safety defines the ROE as the radius constructed with the gas’s point of escape as its center and its length calculated by the following Pasquill-Gifford equations:

To determine the extent of the **100 ppm ROE**:

$$x = [(1.589) (\text{mole fraction H}_2\text{S})(Q)]^{(.6258)}$$

To determine the extent of the **500 ppm ROE**:

$$x = [(0.4546) (\text{mole fraction H}_2\text{S})(Q)]^{(.6258)}$$

Table 8.2. Calculating H₂S Radius of Exposure

ROE Variable	Description
X =	ROE in feet
Q =	Max volume of gas released determined to be released in cubic feet per day (ft³/d) normalized to standard temperature and pressure, 60°F and 14.65 psia
<i>Mole fraction H₂S</i> =	Mole fraction of H ₂ S in the gaseous mixture released.

The volume used as the escape rate in determining the ROE is specified in the rule as follows:

- The maximum daily volume rate of gas containing H₂S handled by that system element for which the ROE is calculated.
- For existing gas wells, the current adjusted open-flow rate, or the operator's estimate of the well's capacity to flow against zero back-pressure at the wellhead.

New Mexico Oil Conservation Division & BLM Site Requirements under NMAC 19.15.11 & Onshore Order #6

- Two cleared areas will be designated as Safe Briefing Areas. During an emergency, personnel will assemble in one of these areas for instructions from the Permian Resources Person-in-Charge. Prevailing wind direction should be considered in locating the briefing areas 200’ or more on either side of the well head. One area should offset the other at an angle of 45° to 90° with respect to prevailing wind direction to allow for wind shifts during the work period.
- In the event of either an intentional or accidental releases of hydrogen sulfide, safeguards to protect the general public from the harmful effects of hydrogen sulfide must be in place for operations. A summary of the provisions in each of three H₂S ROE cases is included in **Table 8.3**.
 - **CASE 1** -100 ppm ROE < 50’
 - **CASE 2** - 100 ppm ROE is 50’ or greater, but < 3000’ and does not penetrate public area.

Permian Resources Corporation	H ₂ S Contingency Plan Koala 9 South Pad	Eddy County, New Mexico
-------------------------------	--	-------------------------

- **CASE 3** -100 ppm ROE is 50' or greater and penetrates a public area or 500 ppm ROE includes a public road. Also if 100 ppm ROE > 3000' regardless of public area.

Table 8.3. NMAC 19.15.11 Compliance Requirements Drilling & Production

NMAC 19.15.11 & BLM COMPLIANCE REQUIREMENTS – DRILLING & PRODUCTION			
PROVISION	CASE 1	CASE 2	CASE 3
H ₂ S Concentration Test	X	X	X
H-9	X	X	X
Training	X	X	X
District Office Notification	X	X	X
Drill Stem Tests Restricted	X*	X*	X
BOP Test	X*	X*	X
Materials		X	X
Warning and Marker		X	X
Security		X	X
Contingency Plan			X
Control and Equipment Safety			X
Monitors		X**	X**
Mud (ph Control or Scavenger)			X*
Wind Indicators		X**	X
Protective Breathing Equipment		X**	X
Choke Manifold, Secondary Remote Control, and Mud-Gas Separator			X
Flare Stacks			X*

Section 9.0 - Training Requirements**Training**

The following elements are considered a minimum level of training for personnel assigned to operations who may encounter H₂S as part of routine or maintenance work.

- The hazards, characteristics, and properties of hydrogen sulfide (H₂S) and (SO₂).
- Sources of H₂S and SO₂.
- Proper use of H₂S and SO₂ detection methods used at the workplace.
- Recognition of, and proper response to, the warning signals initiated by H₂S and SO₂ detection systems in use at the workplace.
- Symptoms of H₂S exposure; symptoms of SO₂ exposure
- Rescue techniques and first aid to victims of H₂S and SO₂ exposure.
- Proper use and maintenance of breathing equipment for working in H₂S and SO₂ atmospheres, as appropriate theory and hands-on practice, with demonstrated proficiency (29 CFR Part 1910.134).
- Workplace practices and relevant maintenance procedures that have been established to protect personnel from the hazards of H₂S and SO₂.
- Wind direction awareness and routes of egress.
- Confined space and enclosed facility entry procedures (if applicable).

Permian Resources Corporation	H ₂ S Contingency Plan Koala 9 South Pad	Eddy County, New Mexico
-------------------------------	--	-------------------------

- Emergency response procedures that have been developed for the facility or operations.
- Locations and use of safety equipment.
- Locations of safe briefing areas.

Refresher training will be conducted annually.

Section 10.0 - Personal Protective Equipment

I. Personal H₂S Monitors

All personnel engaged in planned or unplanned work activity to mitigate the release of a hazardous concentration of H₂S shall have on their person a personal H₂S monitor.

II. Fixed H₂S Detection and Alarms

- 4 channel H₂S monitor
- 4 wireless H₂S monitors
- H₂S alarm system (Audible/Red strobe)
- Personal gas monitor for each person on location
- Gas sample tubes

III. Flame Resistant Clothing

All personnel engaged in planned or unplanned work activity associated with this Plan shall have on the appropriate level of FRC clothing.

IV. Respiratory Protection

The following respiratory protection equipment shall be available at each drilling location.

- Working cascade system available on rig floor and pit system & 750' of air line hose
- Four (4) breathing air manifolds
- Four (4) 30-minute rescue packs
- Five (5) work/Escape units
- Five (5) escape units
- One (1) filler hose for the work/escape/rescue units

Supplied air (airline or SCBA) respiratory protection against hydrogen sulfide exposure is required in the following situations:

- When routine or maintenance work tasks involve exposure to H₂S concentrations of 10 ppm or greater.
- When a fixed location area monitor alarms, and re-entry to the work area is required to complete a job.
- When confined spaces are to be entered without knowledge of H₂S levels present, or if initial measurements are to be taken of H₂S levels.
- During rescue of employees suspected of H₂S overexposure.
- For specific tasks identified with significant exposure potential and outlined in local program guidelines.
- All respiratory equipment for hydrogen sulfide must be of the supplied-air type, equipped with pressure-demand regulators and operated in the pressure-demand mode only. This is the only type of respiratory protection recommended for hydrogen sulfide application. Equipment should be approved by NIOSH/MSHA or other recognized national authority as required. If airline units are used, a five-minute egress bottle should also be carried.
- Gas masks or other air-purifying respirators MUST NEVER BE USED FOR HYDROGEN SULFIDE due to the poor warning properties of the gas.

Permian Resources Corporation	H ₂ S Contingency Plan Koala 9 South Pad	Eddy County, New Mexico
-------------------------------	--	-------------------------

- Use of respiratory protection should be accompanied by a written respiratory protection program.

Permian Resources Corporation	H ₂ S Contingency Plan Koala 9 South Pad	Eddy County, New Mexico
-------------------------------	--	-------------------------



Hydrogen sulfide

Safety Data Sheet E-4611

according to the Hazardous Products Regulation (February 11, 2015)

Date of issue: 10-15-1979

Revision date: 08-10-2016

Supersedes: 10-15-2013

Do not breathe gas
Use and store only outdoors or in a well-ventilated area
Avoid release to the environment
Wear protective gloves, protective clothing, eye protection, respiratory protection, and/or face protection
Leaking gas fire: Do not extinguish, unless leak can be stopped safely
In case of leakage, eliminate all ignition sources
Store locked up
Dispose of contents/container in accordance with container Supplier/owner instructions
Protect from sunlight when ambient temperature exceeds 52°C (125°F)
Close valve after each use and when empty
Do not open valve until connected to equipment prepared for use
When returning cylinder, install leak tight valve outlet cap or plug
Do not depend on odour to detect the presence of gas

2.3. Other hazards

Other hazards not contributing to the classification : Contact with liquid may cause cold burns/frostbite.

2.4. Unknown acute toxicity (GHS-CA)

No data available

SECTION 3: Composition/information on ingredients

3.1. Substances

Name	CAS No.	% (Vol.)	Common Name (synonyms)
Hydrogen sulfide (Main constituent)	(CAS No) 7783-06-4	100	Hydrogen sulfide (H ₂ S) / Hydrogen sulphide / Sulfur hydride / Sulfureted hydrogen / Dihydrogen sulphide / Hydrogensulfide

3.2. Mixtures

Not applicable

SECTION 4: First-aid measures

4.1. Description of first aid measures

First-aid measures after inhalation : Remove to fresh air and keep at rest in a position comfortable for breathing. If not breathing, give artificial respiration. If breathing is difficult, trained personnel should give oxygen. Call a physician.

First-aid measures after skin contact : The liquid may cause frostbite. For exposure to liquid, immediately warm frostbite area with warm water not to exceed 105°F (41°C). Water temperature should be tolerable to normal skin. Maintain skin warming for at least 15 minutes or until normal coloring and sensation have returned to the affected area. In case of massive exposure, remove clothing while showering with warm water. Seek medical evaluation and treatment as soon as possible.

First-aid measures after eye contact : Immediately flush eyes thoroughly with water for at least 15 minutes. Hold the eyelids open and away from the eyeballs to ensure that all surfaces are flushed thoroughly. Contact an ophthalmologist immediately.

First-aid measures after ingestion : Ingestion is not considered a potential route of exposure.

4.2. Most important symptoms and effects (acute and delayed)

No additional information available

4.3. Immediate medical attention and special treatment, if necessary

Other medical advice or treatment : Obtain medical assistance. Treat with corticosteroid spray as soon as possible after inhalation.

SECTION 5: Fire-fighting measures

5.1. Suitable extinguishing media

Suitable extinguishing media : Carbon dioxide, Dry chemical, Water spray or fog. Use extinguishing media appropriate for surrounding fire.

5.2. Unsuitable extinguishing media

No additional information available

This document is only controlled while on the Praxair Canada Inc. website and a copy of this controlled version is available for download. Praxair cannot assure the integrity or accuracy of any version of this document after it has been downloaded or removed from our website.

Permian Resources Corporation	H ₂ S Contingency Plan Koala 9 South Pad	Eddy County, New Mexico
-------------------------------	--	-------------------------



Hydrogen sulfide

Safety Data Sheet E-4611

according to the Hazardous Products Regulation (February 11, 2015)

Date of issue: 10-15-1979

Revision date: 08-10-2016

Supersedes: 10-15-2013

5.3. Specific hazards arising from the hazardous product

Fire hazard	: EXTREMELY FLAMMABLE GAS. If venting or leaking gas catches fire, do not extinguish flames. Flammable vapors may spread from leak, creating an explosive reignition hazard. Vapors can be ignited by pilot lights, other flames, smoking, sparks, heaters, electrical equipment, static discharge, or other ignition sources at locations distant from product handling point. Explosive atmospheres may linger. Before entering an area, especially a confined area, check the atmosphere with an appropriate device.
Explosion hazard	: EXTREMELY FLAMMABLE GAS. Forms explosive mixtures with air and oxidizing agents.
Reactivity	: No reactivity hazard other than the effects described in sub-sections below.
Reactivity in case of fire	: No reactivity hazard other than the effects described in sub-sections below.

5.4. Special protective equipment and precautions for fire-fighters

Firefighting instructions	: DANGER! Toxic, flammable liquefied gas Evacuate all personnel from the danger area. Use self-contained breathing apparatus (SCBA) and protective clothing. Immediately cool containers with water from maximum distance. Stop flow of gas if safe to do so, while continuing cooling water spray. Remove ignition sources if safe to do so. Remove containers from area of fire if safe to do so. On-site fire brigades must comply with their provincial and local fire code regulations.
Special protective equipment for fire fighters	: Standard protective clothing and equipment (Self Contained Breathing Apparatus) for fire fighters.
Other information	: Containers are equipped with a pressure relief device. (Exceptions may exist where authorized by TC.).

SECTION 6: Accidental release measures

6.1. Personal precautions, protective equipment and emergency procedures

General measures	: DANGER! Toxic, flammable liquefied gas . Forms explosive mixtures with air and oxidizing agents. Immediately evacuate all personnel from danger area. Use self-contained breathing apparatus where needed. Remove all sources of ignition if safe to do so. Reduce vapors with fog or fine water spray, taking care not to spread liquid with water. Shut off flow if safe to do so. Ventilate area or move container to a well-ventilated area. Flammable vapors may spread from leak and could explode if reignited by sparks or flames. Explosive atmospheres may linger. Before entering area, especially confined areas, check atmosphere with an appropriate device.
------------------	---

6.2. Methods and materials for containment and cleaning up

Methods for cleaning up	: Try to stop release. Reduce vapour with fog or fine water spray. Prevent waste from contaminating the surrounding environment. Prevent soil and water pollution. Dispose of contents/container in accordance with local/regional/national/international regulations. Contact supplier for any special requirements.
-------------------------	---

6.3. Reference to other sections

For further information refer to section 8: Exposure controls/personal protection

SECTION 7: Handling and storage

7.1. Precautions for safe handling

Precautions for safe handling	: Leak-check system with soapy water; never use a flame All piped systems and associated equipment must be grounded Keep away from heat, hot surfaces, sparks, open flames and other ignition sources. No smoking. Use only non-sparking tools. Use only explosion-proof equipment Wear leather safety gloves and safety shoes when handling cylinders. Protect cylinders from physical damage; do not drag, roll, slide or drop. While moving cylinder, always keep in place removable valve cover. Never attempt to lift a cylinder by its cap; the cap is intended solely to protect the valve. When moving cylinders, even for short distances, use a cart (trolley, hand truck, etc.) designed to transport cylinders. Never insert an object (e.g. wrench, screwdriver, pry bar) into cap openings; doing so may damage the valve and cause a leak. Use an adjustable strap wrench to remove over-tight or rusted caps. Slowly open the valve. If the valve is hard to open, discontinue use and contact your supplier. Close the container valve after each use; keep closed even when empty. Never apply flame or localized heat directly to any part of the container. High temperatures may damage the container and could cause the pressure relief device to fail prematurely, venting the container contents. For other precautions in using this product, see section 16.
-------------------------------	--

This document is only controlled while on the Praxair Canada Inc. website and a copy of this controlled version is available for download. Praxair cannot assure the integrity or accuracy of any version of this document after it has been downloaded or removed from our website.

EN (English)

SDS ID : E-4611

3/9

Permian Resources Corporation	H ₂ S Contingency Plan Koala 9 South Pad	Eddy County, New Mexico
-------------------------------	--	-------------------------

PRAXAIR **Hydrogen sulfide**
Safety Data Sheet E-4611

according to the Hazardous Products Regulation (February 11, 2015)
Date of issue: 10-15-1979 Revision date: 08-10-2016 Supersedes: 10-15-2013

7.2. Conditions for safe storage, including any incompatibilities

Storage conditions : Store only where temperature will not exceed 125°F (52°C). Post "No Smoking/No Open Flames" signs in storage and use areas. There must be no sources of ignition. Separate packages and protect against potential fire and/or explosion damage following appropriate codes and requirements (e.g. NFPA 30, NFPA 55, NFPA 70, and/or NFPA 221 in the U.S.) or according to requirements determined by the Authority Having Jurisdiction (AHJ). Always secure containers upright to keep them from falling or being knocked over. Install valve protection cap, if provided, firmly in place by hand when the container is not in use. Store full and empty containers separately. Use a first-in, first-out inventory system to prevent storing full containers for long periods. For other precautions in using this product, see section 16

OTHER PRECAUTIONS FOR HANDLING, STORAGE, AND USE: When handling product under pressure, use piping and equipment adequately designed to withstand the pressures to be encountered. Never work on a pressurized system. Use a back flow preventive device in the piping. Gases can cause rapid suffocation because of oxygen deficiency; store and use with adequate ventilation. If a leak occurs, close the container valve and blow down the system in a safe and environmentally correct manner in compliance with all international, federal/national, state/provincial, and local laws; then repair the leak. Never place a container where it may become part of an electrical circuit.

SECTION 8: Exposure controls/personal protection

8.1. Control parameters

Hydrogen sulfide (7783-06-4)		
USA - ACGIH	ACGIH TLV-TWA (ppm)	1 ppm
USA - ACGIH	ACGIH TLV-STEL (ppm)	5 ppm
USA - OSHA	OSHA PEL (Ceiling) (ppm)	20 ppm
Canada (Quebec)	VECD (mg/m ³)	21 mg/m ³
Canada (Quebec)	VECD (ppm)	15 ppm
Canada (Quebec)	VEMP (mg/m ³)	14 mg/m ³
Canada (Quebec)	VEMP (ppm)	10 ppm
Alberta	OEL Ceiling (mg/m ³)	21 mg/m ³
Alberta	OEL Ceiling (ppm)	15 ppm
Alberta	OEL TWA (mg/m ³)	14 mg/m ³
Alberta	OEL TWA (ppm)	10 ppm
British Columbia	OEL Ceiling (ppm)	10 ppm
Manitoba	OEL STEL (ppm)	5 ppm
Manitoba	OEL TWA (ppm)	1 ppm
New Brunswick	OEL STEL (mg/m ³)	21 mg/m ³
New Brunswick	OEL STEL (ppm)	15 ppm
New Brunswick	OEL TWA (mg/m ³)	14 mg/m ³
New Brunswick	OEL TWA (ppm)	10 ppm
New Foundland & Labrador	OEL STEL (ppm)	5 ppm
New Foundland & Labrador	OEL TWA (ppm)	1 ppm
Nova Scotia	OEL STEL (ppm)	5 ppm
Nova Scotia	OEL TWA (ppm)	1 ppm
Nunavut	OEL Ceiling (mg/m ³)	28 mg/m ³
Nunavut	OEL Ceiling (ppm)	20 ppm
Nunavut	OEL STEL (mg/m ³)	21 mg/m ³
Nunavut	OEL STEL (ppm)	15 ppm
Nunavut	OEL TWA (mg/m ³)	14 mg/m ³
Nunavut	OEL TWA (ppm)	10 ppm
Northwest Territories	OEL STEL (ppm)	15 ppm

This document is only controlled while on the Praxair Canada Inc. website and a copy of this controlled version is available for download. Praxair cannot assure the integrity or accuracy of any version of this document after it has been downloaded or removed from our website.

Permian Resources Corporation	H ₂ S Contingency Plan Koala 9 South Pad	Eddy County, New Mexico
-------------------------------	--	-------------------------

PRAXAIR **Hydrogen sulfide**
Safety Data Sheet E-4611

according to the Hazardous Products Regulation (February 11, 2015)
Date of issue: 10-15-1979 Revision date: 08-10-2016 Supersedes: 10-15-2013

Hydrogen sulfide (7783-06-4)		
Northwest Territories	OEL TWA (ppm)	10 ppm
Ontario	OEL STEL (ppm)	15 ppm
Ontario	OEL TWA (ppm)	10 ppm
Prince Edward Island	OEL STEL (ppm)	5 ppm
Prince Edward Island	OEL TWA (ppm)	1 ppm
Québec	VECD (mg/m ³)	21 mg/m ³
Québec	VECD (ppm)	15 ppm
Québec	VEMP (mg/m ³)	14 mg/m ³
Québec	VEMP (ppm)	10 ppm
Saskatchewan	OEL STEL (ppm)	15 ppm
Saskatchewan	OEL TWA (ppm)	10 ppm
Yukon	OEL STEL (mg/m ³)	27 mg/m ³
Yukon	OEL STEL (ppm)	15 ppm
Yukon	OEL TWA (mg/m ³)	15 mg/m ³
Yukon	OEL TWA (ppm)	10 ppm

8.2. Appropriate engineering controls

Appropriate engineering controls : Use corrosion-resistant equipment. Use an explosion-proof local exhaust system. Local exhaust and general ventilation must be adequate to meet exposure standards. **MECHANICAL (GENERAL): Inadequate - Use only in a closed system.** Use explosion proof equipment and lighting.

8.3. Individual protection measures/Personal protective equipment

Personal protective equipment : Safety glasses. Face shield. Gloves.



Hand protection : Wear work gloves when handling containers. Wear heavy rubber gloves where contact with product may occur.

Eye protection : Wear goggles and a face shield when transfilling or breaking transfer connections. Select in accordance with the current CSA standard Z94.3, "Industrial Eye and Face Protection", and any provincial regulations, local bylaws or guidelines.

Respiratory protection : **Respiratory protection:** Use respirable fume respirator or air supplied respirator when working in confined space or where local exhaust or ventilation does not keep exposure below TLV. Select in accordance with provincial regulations, local bylaws or guidelines. Selection should be based on the current CSA standard Z94.4, "Selection, Care, and Use of Respirators." Respirators should also be approved by NIOSH and MSHA. For emergencies or instances with unknown exposure levels, use a self-contained breathing apparatus (SCBA).

Thermal hazard protection : Wear cold insulating gloves when transfilling or breaking transfer connections. Standard EN 511 - Cold insulating gloves.

Other information : **Other protection :** Safety shoes for general handling at customer sites. Metatarsal shoes and cuffless trousers for cylinder handling at packaging and filling plants. Select in accordance with the current CSA standard Z195, "Protective Foot Wear", and any provincial regulations, local bylaws or guidelines. For working with flammable and oxidizing materials, consider the use of flame resistant anti-static safety clothing.

SECTION 9: Physical and chemical properties

9.1. Information on basic physical and chemical properties

Physical state : Gas

Appearance : Colorless gas. Colorless liquid at low temperature or under high pressure.

Molecular mass : 34 g/mol

Colour : Colourless.

Odour : Odour can persist. Poor warning properties at low concentrations. Rotten eggs.

Odour threshold : Odour threshold is subjective and inadequate to warn of overexposure.

This document is only controlled while on the Praxair Canada Inc. website and a copy of this controlled version is available for download. Praxair cannot assure the integrity or accuracy of any version of this document after it has been downloaded or removed from our website.

Permian Resources Corporation	H ₂ S Contingency Plan Koala 9 South Pad	Eddy County, New Mexico
-------------------------------	--	-------------------------



Hydrogen sulfide

Safety Data Sheet E-4611

according to the Hazardous Products Regulation (February 11, 2015)

Date of issue: 10-15-1979

Revision date: 08-10-2016

Supersedes: 10-15-2013

pH	: Not applicable.
pH solution	: No data available
Relative evaporation rate (butylacetate=1)	: No data available
Relative evaporation rate (ether=1)	: Not applicable.
Melting point	: -86 °C
Freezing point	: -82.9 °C
Boiling point	: -60.3 °C
Flash point	: Not applicable.
Critical temperature	: 100.4 °C
Auto-ignition temperature	: 260 °C
Decomposition temperature	: No data available
Vapour pressure	: 1880 kPa
Vapour pressure at 50 °C	: No data available
Critical pressure	: 8940 kPa
Relative vapour density at 20 °C	: >=
Relative density	: No data available
Relative density of saturated gas/air mixture	: No data available
Density	: No data available
Relative gas density	: 1.2
Solubility	: Water: 3980 mg/l
Log Pow	: Not applicable.
Log Kow	: Not applicable.
Viscosity, kinematic	: Not applicable.
Viscosity, dynamic	: Not applicable.
Viscosity, kinematic (calculated value) (40 °C)	: No data available
Explosive properties	: Not applicable.
Oxidizing properties	: None.
Flammability (solid, gas)	: 4.3 - 46 vol %

9.2. Other information

Gas group	: Liquefied gas
Additional information	: Gas/vapour heavier than air. May accumulate in confined spaces, particularly at or below ground level

SECTION 10: Stability and reactivity

10.1. Reactivity

Reactivity	: No reactivity hazard other than the effects described in sub-sections below.
Chemical stability	: Stable under normal conditions.
Possibility of hazardous reactions	: May react violently with oxidants. Can form explosive mixture with air.
Conditions to avoid	: Avoid moisture in installation systems. Keep away from heat/sparks/open flames/hot surfaces. – No smoking.
Incompatible materials	: Ammonia. Bases. Bromine pentafluoride. Chlorine trifluoride. chromium trioxide. (and heat). Copper. (powdered). Fluorine. Lead. Lead oxide. Mercury. Nitric acid. Nitrogen trifluoride. nitrogen sulfide. Organic compounds. Oxidizing agents. Oxygen difluoride. Rubber. Sodium. (and moisture). Water.
Hazardous decomposition products	: Thermal decomposition may produce : Sulfur. Hydrogen.

SECTION 11: Toxicological information

11.1. Information on toxicological effects

Acute toxicity (oral)	: Not classified
Acute toxicity (dermal)	: Not classified

This document is only controlled while on the Praxair Canada Inc. website and a copy of this controlled version is available for download. Praxair cannot assure the integrity or accuracy of any version of this document after it has been downloaded or removed from our website.

EN (English)

SDS ID : E-4611

6/9

Permian Resources Corporation	H ₂ S Contingency Plan Koala 9 South Pad	Eddy County, New Mexico
-------------------------------	--	-------------------------



Hydrogen sulfide

Safety Data Sheet E-4611

according to the Hazardous Products Regulation (February 11, 2015)

Date of issue: 10-15-1979

Revision date: 08-10-2016

Supersedes: 10-15-2013

Acute toxicity (inhalation) : Inhalation:gas: FATAL IF INHALED.

Hydrogen sulfide (f)7783-06-4	
LC50 inhalation rat (mg/l)	0.99 mg/l (Exposure time: 1 h)
LC50 inhalation rat (ppm)	356 ppm/4h
ATE CA (gases)	356.00000000 ppmv/4h
ATE CA (vapours)	0.99000000 mg/l/4h
ATE CA (dust,mist)	0.99000000 mg/l/4h

Skin corrosion/irritation : Not classified

pH: Not applicable.

Serious eye damage/irritation : Not classified

pH: Not applicable.

Respiratory or skin sensitization : Not classified

Germ cell mutagenicity : Not classified

Carcinogenicity : Not classified

Reproductive toxicity : Not classified

Specific target organ toxicity (single exposure) : MAY CAUSE RESPIRATORY IRRITATION.

Specific target organ toxicity (repeated exposure) : Not classified

Aspiration hazard : Not classified

SECTION 12: Ecological information

12.1. Toxicity

Ecology - general : VERY TOXIC TO AQUATIC LIFE.

Hydrogen sulfide (7783-06-4)	
LC50 fish 1	0.0448 mg/l (Exposure time: 96 h - Species: Lepomis macrochirus [flow-through])
LC50 fish 2	0.016 mg/l (Exposure time: 96 h - Species: Pimephales promelas [flow-through])

12.2. Persistence and degradability

Hydrogen sulfide (7783-06-4)	
Persistence and degradability	Not applicable for inorganic gases.

12.3. Bioaccumulative potential

Hydrogen sulfide (7783-06-4)	
BCF fish 1	(no bioaccumulation expected)
Log Pow	Not applicable.
Log Kow	Not applicable.
Bioaccumulative potential	No data available.

12.4. Mobility in soil

Hydrogen sulfide (7783-06-4)	
Mobility in soil	No data available.
Log Pow	Not applicable.
Log Kow	Not applicable.
Ecology - soil	Because of its high volatility, the product is unlikely to cause ground or water pollution.

12.5. Other adverse effects

Other adverse effects : May cause pH changes in aqueous ecological systems.

Effect on the ozone layer : None

Effect on global warming : No known effects from this product

This document is only controlled while on the Praxair Canada Inc. website and a copy of this controlled version is available for download. Praxair cannot assure the integrity or accuracy of any version of this document after it has been downloaded or removed from our website.

EN (English)

SDS ID : E-4611

7/9

Permian Resources Corporation	H ₂ S Contingency Plan Koala 9 South Pad	Eddy County, New Mexico
-------------------------------	--	-------------------------



Hydrogen sulfide

Safety Data Sheet E-4611

according to the Hazardous Products Regulation (February 11, 2015)

Date of issue: 10-15-1979

Revision date: 08-10-2016

Supersedes: 10-15-2013

SECTION 13: Disposal considerations

13.1. Disposal methods

Waste disposal recommendations : Do not attempt to dispose of residual or unused quantities. Return container to supplier.

SECTION 14: Transport information

14.1. Basic shipping description

In accordance with TDG

TDG

UN-No. (TDG) : UN1053
 TDG Primary Hazard Classes : 2.3 - Class 2.3 - Toxic Gas.
 TDG Subsidiary Classes : 2.1
 Proper shipping name : HYDROGEN SULPHIDE

ERAP Index : 500
 Explosive Limit and Limited Quantity Index : 0
 Passenger Carrying Ship Index : Forbidden
 Passenger Carrying Road Vehicle or Passenger Carrying Railway Vehicle Index : Forbidden

14.3. Air and sea transport

IMDG

UN-No. (IMDG) : 1053
 Proper Shipping Name (IMDG) : HYDROGEN SULPHIDE
 Class (IMDG) : 2 - Gases
 MFAG-No : 117

IATA

UN-No. (IATA) : 1053
 Proper Shipping Name (IATA) : Hydrogen sulphide
 Class (IATA) : 2

SECTION 15: Regulatory information

15.1. National regulations

Hydrogen sulfide (7783-06-4)

Listed on the Canadian DSL (Domestic Substances List)

15.2. International regulations

Hydrogen sulfide (7783-06-4)

Listed on the AICS (Australian Inventory of Chemical Substances)
 Listed on IECSC (Inventory of Existing Chemical Substances Produced or Imported in China)
 Listed on the EEC inventory EINECS (European Inventory of Existing Commercial Chemical Substances)
 Listed on the Japanese ENCS (Existing & New Chemical Substances) inventory
 Listed on the Korean ECL (Existing Chemicals List)
 Listed on NZIoC (New Zealand Inventory of Chemicals)
 Listed on PICCS (Philippines Inventory of Chemicals and Chemical Substances)
 Listed on the United States TSCA (Toxic Substances Control Act) inventory
 Listed on INSQ (Mexican national Inventory of Chemical Substances)

SECTION 16: Other information

Date of issue : 15/10/1979
 Revision date : 10/08/2016
 Supersedes : 15/10/2013

Indication of changes:

Training advice : Users of breathing apparatus must be trained. Ensure operators understand the toxicity hazard. Ensure operators understand the flammability hazard.

This document is only controlled while on the Praxair Canada Inc. website and a copy of this controlled version is available for download. Praxair cannot assure the integrity or accuracy of any version of this document after it has been downloaded or removed from our website.

Permian Resources Corporation	H ₂ S Contingency Plan Koala 9 South Pad	Eddy County, New Mexico
-------------------------------	--	-------------------------

PRAXAIR **Hydrogen sulfide**
Safety Data Sheet E-4611

according to the Hazardous Products Regulation (February 11, 2015)
Date of issue: 10-15-1979 Revision date: 08-10-2016 Supersedes: 10-15-2013

Other information : When you mix two or more chemicals, you can create additional, unexpected hazards. Obtain and evaluate the safety information for each component before you produce the mixture. Consult an industrial hygienist or other trained person when you evaluate the end product. Before using any plastics, confirm their compatibility with this product

Praxair asks users of this product to study this SDS and become aware of the product hazards and safety information. To promote safe use of this product, a user should (1) notify employees, agents, and contractors of the information in this SDS and of any other known product hazards and safety information, (2) furnish this information to each purchaser of the product, and (3) ask each purchaser to notify its employees and customers of the product hazards and safety information

The opinions expressed herein are those of qualified experts within Praxair Canada Inc. We believe that the information contained herein is current as of the date of this Safety Data Sheet. Since the use of this information and the conditions of use are not within the control of Praxair Canada Inc, it is the user's obligation to determine the conditions of safe use of the product. Praxair Canada Inc, SDSs are furnished on sale or delivery by Praxair Canada Inc, or the independent distributors and suppliers who package and sell our products. To obtain current SDSs for these products, contact your Praxair sales representative, local distributor, or supplier, or download from www.praxair.ca. If you have questions regarding Praxair SDSs, would like the document number and date of the latest SDS, or would like the names of the Praxair suppliers in your area, phone or write Praxair Canada Inc, (Phone: 1-888-257-5149; Address: Praxair Canada Inc, 1 City Centre Drive, Suite 1200, Mississauga, Ontario, L5B 1M2).

PRAXAIR and the Flowing Airstream design are trademarks or registered trademarks of Praxair Technology, Inc. in the United States and/or other countries.

- NFPA health hazard : 4 - Very short exposure could cause death or serious residual injury even though prompt medical attention was given.
- NFPA fire hazard : 4 - Will rapidly or completely vaporize at normal pressure and temperature, or is readily dispersed in air and will burn readily.
- NFPA reactivity : 0 - Normally stable, even under fire exposure conditions, and are not reactive with water.

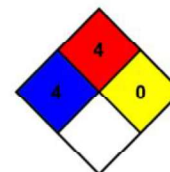

- HMS III Rating
 - Health : 2 Moderate Hazard - Temporary or minor injury may occur
 - Flammability : 4 Severe Hazard - Flammable gases, or very volatile flammable liquids with flash points below 73 F, and boiling points below 100 F. Materials may ignite spontaneously with air. (Class IA)
 - Physical : 2 Moderate Hazard - Materials that are unstable and may undergo violent chemical changes at normal temperature and pressure with low risk for explosion. Materials may react violently with water or form peroxides upon exposure to air.

SDS Canada (GHS) - Praxair

This information is based on our current knowledge and is intended to describe the product for the purposes of health, safety and environmental requirements only. It should not therefore be construed as guaranteeing any specific property of the product.

Permian Resources Corporation	H ₂ S Contingency Plan Koala 9 South Pad	Eddy County, New Mexico
-------------------------------	--	-------------------------

SO₂ SDS

Safety Data Sheet

Material Name: SULFUR DIOXIDE

SDS ID: MAT22290

Section 1 - PRODUCT AND COMPANY IDENTIFICATION**Material Name**

SULFUR DIOXIDE

Synonyms

MTG MSDS 80; SULFUROUS ACID ANHYDRIDE; SULFUROUS OXIDE; SULPHUR DIOXIDE;
SULFUROUS ANHYDRIDE; FERMENTICIDE LIQUID; SULFUR DIOXIDE(SO₂); SULFUR OXIDE;
SULFUR OXIDE(SO₂)

Chemical Family

inorganic, gas

Product Description

Classification determined in accordance with Compressed Gas Association standards.

Product Use

Industrial and Specialty Gas Applications.

Restrictions on Use

None known.

Details of the supplier of the safety data sheet

MATHESON TRI-GAS, INC.

3 Mountainview Road

Warren, NJ 07059

General Information: 1-800-416-2505

Emergency #: 1-800-424-9300 (CHEMTREC)

Outside the US: 703-527-3887 (Call collect)

Section 2 - HAZARDS IDENTIFICATION**Classification in accordance with paragraph (d) of 29 CFR 1910.1200.**

Gases Under Pressure - Liquefied gas

Acute Toxicity - Inhalation - Gas - Category 3

Skin Corrosion/Irritation - Category 1B

Serious Eye Damage/Eye Irritation - Category 1

Simple Asphyxiant

GHS Label Elements**Symbol(s)****Signal Word**

Danger

Hazard Statement(s)

Contains gas under pressure; may explode if heated.

Toxic if inhaled.

Causes severe skin burns and eye damage.

May displace oxygen and cause rapid suffocation.

Precautionary Statement(s)**Prevention**

Use only outdoors or in a well-ventilated area.

Wear protective gloves/protective clothing/eye protection/face protection.

Permian Resources Corporation	H ₂ S Contingency Plan Koala 9 South Pad	Eddy County, New Mexico
-------------------------------	--	-------------------------



Safety Data Sheet

Material Name: SULFUR DIOXIDE

SDS ID: MAT22290

Wash thoroughly after handling.

Do not breathe dusts or mists.

Response

IF INHALED: Remove person to fresh air and keep comfortable for breathing.

IF IN EYES: Rinse cautiously with water for several minutes. Remove contact lenses, if present and easy to do.

Continue rinsing.

IF ON SKIN (or hair): Remove/take off immediately all contaminated clothing. Rinse skin with water/shower.

Wash contaminated clothing before reuse.

IF SWALLOWED: Rinse mouth. Do NOT induce vomiting.

Immediately call a POISON CENTER or doctor.

Specific treatment (see label).

Storage

Store in a well-ventilated place. Keep container tightly closed.

Store locked up.

Protect from sunlight.

Disposal

Dispose of contents/container in accordance with local/regional/national/international regulations.

Other Hazards

Contact with liquified gas may cause frostbite.

Section 3 - COMPOSITION / INFORMATION ON INGREDIENTS

CAS	Component Name	Percent
7446-09-5	Sulfur dioxide	100.0

Section 4 - FIRST AID MEASURES

Inhalation

IF INHALED: Remove person to fresh air and keep at rest in a position comfortable for breathing. Get immediate medical attention.

Skin

IF ON SKIN (or hair): Remove/take off immediately all contaminated clothing. Rinse skin with water/shower. Wash contaminated clothing before reuse. If frostbite or freezing occur, immediately flush with plenty of lukewarm water (105-115°F; 41-46°C). If warm water is not available, gently wrap affected parts in blankets. DO NOT induce vomiting. Get immediate medical attention.

Eyes

IF IN EYES: Rinse cautiously with water for several minutes. Remove contact lenses, if present and easy to do.

Continue rinsing. Get immediate medical attention.

Ingestion

IF SWALLOWED: Rinse mouth. Do NOT induce vomiting. Get immediate medical attention.

Most Important Symptoms/Effects

Acute

Toxic if inhaled, frostbite, suffocation, respiratory tract burns, skin burns, eye burns.

Delayed

No information on significant adverse effects.

Indication of any immediate medical attention and special treatment needed

Treat symptomatically and supportively.

Note to Physicians

For inhalation, consider oxygen.

Permian Resources Corporation	H ₂ S Contingency Plan Koala 9 South Pad	Eddy County, New Mexico
-------------------------------	--	-------------------------



Safety Data Sheet

Material Name: SULFUR DIOXIDE

SDS ID: MAT22290

Section 5 - FIRE FIGHTING MEASURES

Extinguishing Media

Suitable Extinguishing Media

carbon dioxide, regular dry chemical, Large fires: Use regular foam or flood with fine water spray.

Unsuitable Extinguishing Media

None known.

Special Hazards Arising from the Chemical

Negligible fire hazard.

Hazardous Combustion Products

sulfur oxides

Fire Fighting Measures

Move container from fire area if it can be done without risk. Cool containers with water spray until well after the fire is out. Stay away from the ends of tanks. Keep unnecessary people away, isolate hazard area and deny entry.

Special Protective Equipment and Precautions for Firefighters

Wear full protective fire fighting gear including self contained breathing apparatus (SCBA) for protection against possible exposure.

Section 6 - ACCIDENTAL RELEASE MEASURES

Personal Precautions, Protective Equipment and Emergency Procedures

Wear personal protective clothing and equipment, see Section 8.

Methods and Materials for Containment and Cleaning Up

Keep unnecessary people away, isolate hazard area and deny entry. Stay upwind and keep out of low areas.

Ventilate closed spaces before entering. Evacuation radius: 150 feet. Stop leak if possible without personal risk.

Reduce vapors with water spray. Do not get water directly on material.

Environmental Precautions

Avoid release to the environment.

Section 7 - HANDLING AND STORAGE

Precautions for Safe Handling

Do not get in eyes, on skin, or on clothing. Do not breathe gas, fumes, vapor, or spray. Wash hands thoroughly after handling. Use only outdoors or in a well-ventilated area. Wear protective gloves/protective clothing/eye protection/face protection. Contaminated work clothing should not be allowed out of the workplace. Do not eat, drink or smoke when using this product. Keep only in original container. Avoid release to the environment.

Conditions for Safe Storage, Including any Incompatibilities

Store in a well-ventilated place. Keep container tightly closed.

Store locked up.

Protect from sunlight.

Store and handle in accordance with all current regulations and standards. Protect from physical damage. Store outside or in a detached building. Keep separated from incompatible substances.

Incompatible Materials

bases, combustible materials, halogens, metal carbide, metal oxides, metals, oxidizing materials, peroxides, reducing agents

Section 8 - EXPOSURE CONTROLS / PERSONAL PROTECTION

Component Exposure Limits

Sulfur dioxide	7446-09-5
ACGIH:	0.25 ppm STEL

Permian Resources Corporation	H ₂ S Contingency Plan Koala 9 South Pad	Eddy County, New Mexico
-------------------------------	--	-------------------------



Safety Data Sheet

Material Name: SULFUR DIOXIDE

SDS ID: MAT22290

NIOSH:	2 ppm TWA ; 5 mg/m ³ TWA
	5 ppm STEL ; 13 mg/m ³ STEL
	100 ppm IDLH
OSHA (US):	5 ppm TWA ; 13 mg/m ³ TWA
Mexico:	0.25 ppm STEL [PPT-CT]

ACGIH - Threshold Limit Values - Biological Exposure Indices (BEI)

There are no biological limit values for any of this product's components.

Engineering Controls

Provide local exhaust or process enclosure ventilation system. Ensure compliance with applicable exposure limits.

Individual Protection Measures, such as Personal Protective Equipment

Eye/face protection

Wear splash resistant safety goggles with a faceshield. Contact lenses should not be worn. Provide an emergency eye wash fountain and quick drench shower in the immediate work area.

Skin Protection

Wear appropriate chemical resistant clothing. Wear chemical resistant clothing to prevent skin contact.

Respiratory Protection

Any self-contained breathing apparatus that has a full facepiece and is operated in a pressure-demand or other positive-pressure mode.

Glove Recommendations

Wear appropriate chemical resistant gloves.

Section 9 - PHYSICAL AND CHEMICAL PROPERTIES

Appearance	colorless gas	Physical State	gas
Odor	irritating odor	Color	colorless
Odor Threshold	3 - 5 ppm	pH	(Acidic in solution)
Melting Point	-73 °C (-99 °F)	Boiling Point	-10 °C (14 °F)
Boiling Point Range	Not available	Freezing point	Not available
Evaporation Rate	>1 (Butyl acetate = 1)	Flammability (solid, gas)	Not available
Autoignition Temperature	Not available	Flash Point	(Not flammable)
Lower Explosive Limit	Not available	Decomposition temperature	Not available
Upper Explosive Limit	Not available	Vapor Pressure	2432 mmHg @ 20 °C
Vapor Density (air=1)	2.26	Specific Gravity (water=1)	1.462 at -10 °C

Permian Resources Corporation	H ₂ S Contingency Plan Koala 9 South Pad	Eddy County, New Mexico
-------------------------------	--	-------------------------



Safety Data Sheet

Material Name: SULFUR DIOXIDE
SDS ID: MAT22290

Water Solubility	22.8 % (@ 0 °C)	Partition coefficient: n-octanol/water	Not available
Viscosity	Not available	Kinematic viscosity	Not available
Solubility (Other)	Not available	Density	Not available
Physical Form	liquified gas	Molecular Formula	S-O ₂
Molecular Weight	64.06		

Solvent Solubility
Soluble

alcohol, acetic acid, sulfuric acid, ether, chloroform, Benzene, sulfuryl chloride, nitrobenzenes, Toluene, acetone

Section 10 - STABILITY AND REACTIVITY

Reactivity

No reactivity hazard is expected.

Chemical Stability

Stable at normal temperatures and pressure.

Possibility of Hazardous Reactions

Will not polymerize.

Conditions to Avoid

Minimize contact with material. Containers may rupture or explode if exposed to heat.

Incompatible Materials

bases, combustible materials, halogens, metal carbide, metal oxides, metals, oxidizing materials, peroxides, reducing agents

Hazardous decomposition products

oxides of sulfur

Section 11 - TOXICOLOGICAL INFORMATION

Information on Likely Routes of Exposure
Inhalation

Toxic if inhaled. Causes damage to respiratory system, burns, difficulty breathing

Skin Contact

skin burns

Eye Contact

eye burns

Ingestion

burns, nausea, vomiting, diarrhea, stomach pain

Acute and Chronic Toxicity
Component Analysis - LD50/LC50

The components of this material have been reviewed in various sources and the following selected endpoints are published:

Sulfur dioxide (7446-09-5)

Inhalation LC50 Rat 965 - 1168 ppm 4 h

Product Toxicity Data
Acute Toxicity Estimate

No data available.

Immediate Effects

Permian Resources Corporation	H ₂ S Contingency Plan Koala 9 South Pad	Eddy County, New Mexico
-------------------------------	--	-------------------------



Safety Data Sheet

Material Name: SULFUR DIOXIDE

SDS ID: MAT22290

Toxic if inhaled, frostbite, suffocation, respiratory tract burns, skin burns, eye burns

Delayed Effects

No information on significant adverse effects.

Irritation/Corrosivity Data

respiratory tract burns, skin burns, eye burns

Respiratory Sensitization

No data available.

Dermal Sensitization

No data available.

Component Carcinogenicity

Sulfur dioxide	7446-09-5
ACGIH:	A4 - Not Classifiable as a Human Carcinogen
IARC:	Monograph 54 [1992] (Group 3 (not classifiable))

Germ Cell Mutagenicity

No data available.

Tumorigenic Data

No data available

Reproductive Toxicity

No data available.

Specific Target Organ Toxicity - Single Exposure

No target organs identified.

Specific Target Organ Toxicity - Repeated Exposure

No target organs identified.

Aspiration hazard

Not applicable.

Medical Conditions Aggravated by Exposure

respiratory disorders

Section 12 - ECOLOGICAL INFORMATION

Component Analysis - Aquatic Toxicity

No LOLI ecotoxicity data are available for this product's components.

Persistence and Degradability

No data available.

Bioaccumulative Potential

No data available.

Mobility

No data available.

Section 13 - DISPOSAL CONSIDERATIONS

Disposal Methods

Dispose of contents/container in accordance with local/regional/national/international regulations.

Component Waste Numbers

The U.S. EPA has not published waste numbers for this product's components.

Section 14 - TRANSPORT INFORMATION

US DOT Information:

Shipping Name: SULFUR DIOXIDE

Permian Resources Corporation	H ₂ S Contingency Plan Koala 9 South Pad	Eddy County, New Mexico
-------------------------------	--	-------------------------



Safety Data Sheet

Material Name: SULFUR DIOXIDE

SDS ID: MAT22290

Hazard Class: 2.3
UN/NA #: UN1079
Required Label(s): 2.3

IMDG Information:
Shipping Name: SULPHUR DIOXIDE
Hazard Class: 2.3
UN#: UN1079
Required Label(s): 2.3

TDG Information:
Shipping Name: SULFUR DIOXIDE
Hazard Class: 2.3
UN#: UN1079
Required Label(s): 2.3

International Bulk Chemical Code

This material does not contain any chemicals required by the IBC Code to be identified as dangerous chemicals in bulk.

Section 15 - REGULATORY INFORMATION

U.S. Federal Regulations

This material contains one or more of the following chemicals required to be identified under SARA Section 302 (40 CFR 355 Appendix A), SARA Section 313 (40 CFR 372.65), CERCLA (40 CFR 302.4), TSCA 12(b), and/or require an OSHA process safety plan.

Sulfur dioxide	7446-09-5
SARA 302:	500 lb TPQ
OSHA (safety):	1000 lb TQ (Liquid)
SARA 304:	500 lb EPCRA RQ

SARA Section 311/312 (40 CFR 370 Subparts B and C) reporting categories

Gas Under Pressure; Acute toxicity; Skin Corrosion/Irritation; Serious Eye Damage/Eye Irritation; Simple Asphyxiant

U.S. State Regulations

The following components appear on one or more of the following state hazardous substances lists:

Component	CAS	CA	MA	MN	NJ	PA
Sulfur dioxide	7446-09-5	Yes	Yes	Yes	Yes	Yes

California Safe Drinking Water and Toxic Enforcement Act (Proposition 65)



WARNING

This product can expose you to chemicals including Sulfur dioxide , which is known to the State of California to cause birth defects or other reproductive harm. For more information go to www.P65Warnings.ca.gov.

Permian Resources Corporation	H ₂ S Contingency Plan Koala 9 South Pad	Eddy County, New Mexico
-------------------------------	--	-------------------------

MATHESON

ask...The Gas Professionals™

Safety Data Sheet

Material Name: SULFUR DIOXIDE
SDS ID: MAT22290

Sulfur dioxide	7446-09-5
Repro/Dev. Tox	developmental toxicity, 7/29/2011

Component Analysis - Inventory
Sulfur dioxide (7446-09-5)

US	CA	AU	CN	EU	JP - ENCS	JP - ISHL	KR KECI - Annex 1	KR KECI - Annex 2
Yes	DSL	Yes	Yes	EIN	Yes	Yes	Yes	No

KR - REACH CCA	MX	NZ	PH	TH-TECI	TW, CN	VN (Draft)
No	Yes	Yes	Yes	Yes	Yes	Yes

Section 16 - OTHER INFORMATION

NFPA Ratings

Health: 3 Fire: 0 Instability: 0

Hazard Scale: 0 = Minimal 1 = Slight 2 = Moderate 3 = Serious 4 = Severe

Summary of Changes

SDS update: 02/10/2016

Key / Legend

ACGIH - American Conference of Governmental Industrial Hygienists; ADR - European Road Transport; AU - Australia; BOD - Biochemical Oxygen Demand; C - Celsius; CA - Canada; CA/MA/MN/NJ/PA - California/Massachusetts/Minnesota/New Jersey/Pennsylvania*; CAS - Chemical Abstracts Service; CERCLA - Comprehensive Environmental Response, Compensation, and Liability Act; CFR - Code of Federal Regulations (US); CLP - Classification, Labelling, and Packaging; CN - China; CPR - Controlled Products Regulations; DFG - Deutsche Forschungsgemeinschaft; DOT - Department of Transportation; DSD - Dangerous Substance Directive; DSL - Domestic Substances List; EC - European Commission; EEC - European Economic Community; EIN - European Inventory of (Existing Commercial Chemical Substances); EINECS - European Inventory of Existing Commercial Chemical Substances; ENCS - Japan Existing and New Chemical Substance Inventory; EPA - Environmental Protection Agency; EU - European Union; F - Fahrenheit; F - Background (for Venezuela Biological Exposure Indices); IARC - International Agency for Research on Cancer; IATA - International Air Transport Association; ICAO - International Civil Aviation Organization; IDL - Ingredient Disclosure List; IDLH - Immediately Dangerous to Life and Health; IMDG - International Maritime Dangerous Goods; ISHL - Japan Industrial Safety and Health Law; IUCLID - International Uniform Chemical Information Database; JP - Japan; Kow - Octanol/water partition coefficient; KR KECI Annex 1 - Korea Existing Chemicals Inventory (KECI) / Korea Existing Chemicals List (KECL); KR KECI Annex 2 - Korea Existing Chemicals Inventory (KECI) / Korea Existing Chemicals List (KECL), KR - Korea; LD50/LC50 - Lethal Dose/ Lethal Concentration; KR REACH CCA - Korea Registration and Evaluation of Chemical Substances Chemical Control Act; LEL - Lower Explosive Limit; LLV - Level Limit Value; LOLI - List Of Lists™ - ChemADVISOR's Regulatory Database; MAK - Maximum Concentration Value in the Workplace; MEL - Maximum Exposure Limits; MX - Mexico; Ne- Non-specific; NFPA - National Fire Protection Agency; NIOSH - National Institute for Occupational Safety and Health; NJTSR - New Jersey Trade Secret Registry; Nq - Non-quantitative; NSL - Non-Domestic Substance List (Canada); NTP - National Toxicology Program; NZ - New Zealand; OSHA - Occupational Safety and Health Administration; PEL - Permissible Exposure Limit; PH - Philippines; RCRA - Resource Conservation and Recovery Act; REACH - Registration, Evaluation, Authorisation, and restriction of Chemicals; RID - European Rail Transport; SARA - Superfund Amendments and Reauthorization Act; Sc - Semi-quantitative; STEL - Short-term Exposure Limit;

NEW MEXICO

**(SP) EDDY
KOALA FED
KOALA 9 FED COM 124H**

OWB

Plan: PWP0

Standard Planning Report - Geographic

21 October, 2025

Planning Report - Geographic

Database:	Compass_17	Local Co-ordinate Reference:	Well KOALA 9 FED COM 124H
Company:	NEW MEXICO	TVD Reference:	KB @ 3304.0usft
Project:	(SP) EDDY	MD Reference:	KB @ 3304.0usft
Site:	KOALA FED	North Reference:	Grid
Well:	KOALA 9 FED COM 124H	Survey Calculation Method:	Minimum Curvature
Wellbore:	OWB		
Design:	PWP0		

Project	(SP) EDDY		
Map System:	US State Plane 1983	System Datum:	Mean Sea Level
Geo Datum:	North American Datum 1983		
Map Zone:	New Mexico Eastern Zone		

Site	KOALA FED				
Site Position:		Northing:	576,206.86 usft	Latitude:	32° 35' 2.282 N
From:	Map	Easting:	584,833.29 usft	Longitude:	104° 11' 31.620 W
Position Uncertainty:	0.0 usft	Slot Radius:	13-3/16 "		

Well	KOALA 9 FED COM 124H					
Well Position	+N/-S	0.0 usft	Northing:	576,207.24 usft	Latitude:	32° 35' 2.284 N
	+E/-W	0.0 usft	Easting:	584,953.27 usft	Longitude:	104° 11' 30.218 W
Position Uncertainty	0.0 usft		Wellhead Elevation:	usft	Ground Level:	3,274.0 usft
Grid Convergence:	0.08 °					

Wellbore	OWB
-----------------	-----

Magnetics	Model Name	Sample Date	Declination (°)	Dip Angle (°)	Field Strength (nT)
	IGRF200510	12/31/2009	8.06	60.47	48,941.42067239

Design	PWP0
---------------	------

Audit Notes:									
Version:	Phase: PROTOTYPE Tie On Depth: 0.0								
Vertical Section:	<table border="1"> <thead> <tr> <th>Depth From (TVD) (usft)</th> <th>+N/-S (usft)</th> <th>+E/-W (usft)</th> <th>Direction (°)</th> </tr> </thead> <tbody> <tr> <td>0.0</td> <td>0.0</td> <td>0.0</td> <td>93.94</td> </tr> </tbody> </table>	Depth From (TVD) (usft)	+N/-S (usft)	+E/-W (usft)	Direction (°)	0.0	0.0	0.0	93.94
Depth From (TVD) (usft)	+N/-S (usft)	+E/-W (usft)	Direction (°)						
0.0	0.0	0.0	93.94						

Plan Survey Tool Program	Date 10/21/2025			
Depth From (usft)	Depth To (usft)	Survey (Wellbore)	Tool Name	Remarks
1	0.0	17,819.0 PWP0 (OWB)	MWD	OWSG_Rev2_ MWD - Star

Plan Sections										
Measured Depth (usft)	Inclination (°)	Azimuth (°)	Vertical Depth (usft)	+N/-S (usft)	+E/-W (usft)	Dogleg Rate (°/100usft)	Build Rate (°/100usft)	Turn Rate (°/100usft)	TFO (°)	Target
0.0	0.00	0.00	0.0	0.0	0.0	0.00	0.00	0.00	0.00	
2,000.0	0.00	0.00	2,000.0	0.0	0.0	0.00	0.00	0.00	0.00	
2,750.0	15.00	166.07	2,741.5	-94.7	23.5	2.00	2.00	0.00	166.07	
5,230.3	15.00	166.07	5,137.3	-717.8	178.0	0.00	0.00	0.00	0.00	
5,980.3	0.00	0.00	5,878.8	-812.6	201.5	2.00	-2.00	0.00	180.00	
6,953.1	0.00	0.00	6,851.5	-812.6	201.5	0.00	0.00	0.00	0.00	
7,703.1	90.00	89.62	7,329.0	-809.4	679.0	12.00	12.00	11.95	89.62	
17,819.0	90.00	89.62	7,329.0	-743.0	10,794.6	0.00	0.00	0.00	0.00	BHL KOALA 9 FED

Planning Report - Geographic

Database:	Compass_17	Local Co-ordinate Reference:	Well KOALA 9 FED COM 124H
Company:	NEW MEXICO	TVD Reference:	KB @ 3304.0usft
Project:	(SP) EDDY	MD Reference:	KB @ 3304.0usft
Site:	KOALA FED	North Reference:	Grid
Well:	KOALA 9 FED COM 124H	Survey Calculation Method:	Minimum Curvature
Wellbore:	OWB		
Design:	PWPO		

Planned Survey									
Measured Depth (usft)	Inclination (°)	Azimuth (°)	Vertical Depth (usft)	+N/-S (usft)	+E/-W (usft)	Map Northing (usft)	Map Easting (usft)	Latitude	Longitude
0.0	0.00	0.00	0.0	0.0	0.0	576,207.24	584,953.27	32° 35' 2.284 N	104° 11' 30.218 W
100.0	0.00	0.00	100.0	0.0	0.0	576,207.24	584,953.27	32° 35' 2.284 N	104° 11' 30.218 W
200.0	0.00	0.00	200.0	0.0	0.0	576,207.24	584,953.27	32° 35' 2.284 N	104° 11' 30.218 W
300.0	0.00	0.00	300.0	0.0	0.0	576,207.24	584,953.27	32° 35' 2.284 N	104° 11' 30.218 W
400.0	0.00	0.00	400.0	0.0	0.0	576,207.24	584,953.27	32° 35' 2.284 N	104° 11' 30.218 W
500.0	0.00	0.00	500.0	0.0	0.0	576,207.24	584,953.27	32° 35' 2.284 N	104° 11' 30.218 W
600.0	0.00	0.00	600.0	0.0	0.0	576,207.24	584,953.27	32° 35' 2.284 N	104° 11' 30.218 W
700.0	0.00	0.00	700.0	0.0	0.0	576,207.24	584,953.27	32° 35' 2.284 N	104° 11' 30.218 W
800.0	0.00	0.00	800.0	0.0	0.0	576,207.24	584,953.27	32° 35' 2.284 N	104° 11' 30.218 W
900.0	0.00	0.00	900.0	0.0	0.0	576,207.24	584,953.27	32° 35' 2.284 N	104° 11' 30.218 W
1,000.0	0.00	0.00	1,000.0	0.0	0.0	576,207.24	584,953.27	32° 35' 2.284 N	104° 11' 30.218 W
1,100.0	0.00	0.00	1,100.0	0.0	0.0	576,207.24	584,953.27	32° 35' 2.284 N	104° 11' 30.218 W
1,200.0	0.00	0.00	1,200.0	0.0	0.0	576,207.24	584,953.27	32° 35' 2.284 N	104° 11' 30.218 W
1,300.0	0.00	0.00	1,300.0	0.0	0.0	576,207.24	584,953.27	32° 35' 2.284 N	104° 11' 30.218 W
1,400.0	0.00	0.00	1,400.0	0.0	0.0	576,207.24	584,953.27	32° 35' 2.284 N	104° 11' 30.218 W
1,500.0	0.00	0.00	1,500.0	0.0	0.0	576,207.24	584,953.27	32° 35' 2.284 N	104° 11' 30.218 W
1,600.0	0.00	0.00	1,600.0	0.0	0.0	576,207.24	584,953.27	32° 35' 2.284 N	104° 11' 30.218 W
1,700.0	0.00	0.00	1,700.0	0.0	0.0	576,207.24	584,953.27	32° 35' 2.284 N	104° 11' 30.218 W
1,800.0	0.00	0.00	1,800.0	0.0	0.0	576,207.24	584,953.27	32° 35' 2.284 N	104° 11' 30.218 W
1,900.0	0.00	0.00	1,900.0	0.0	0.0	576,207.24	584,953.27	32° 35' 2.284 N	104° 11' 30.218 W
2,000.0	0.00	0.00	2,000.0	0.0	0.0	576,207.24	584,953.27	32° 35' 2.284 N	104° 11' 30.218 W
Start Build 2.00									
2,100.0	2.00	166.07	2,100.0	-1.7	0.4	576,205.55	584,953.69	32° 35' 2.268 N	104° 11' 30.213 W
2,200.0	4.00	166.07	2,199.8	-6.8	1.7	576,200.47	584,954.95	32° 35' 2.217 N	104° 11' 30.198 W
2,300.0	6.00	166.07	2,299.5	-15.2	3.8	576,192.01	584,957.05	32° 35' 2.134 N	104° 11' 30.174 W
2,400.0	8.00	166.07	2,398.7	-27.1	6.7	576,180.18	584,959.98	32° 35' 2.016 N	104° 11' 30.140 W
2,500.0	10.00	166.07	2,497.5	-42.2	10.5	576,165.00	584,963.75	32° 35' 1.866 N	104° 11' 30.096 W
2,600.0	12.00	166.07	2,595.6	-60.8	15.1	576,146.48	584,968.34	32° 35' 1.683 N	104° 11' 30.042 W
2,700.0	14.00	166.07	2,693.1	-82.6	20.5	576,124.65	584,973.75	32° 35' 1.467 N	104° 11' 29.979 W
2,750.0	15.00	166.07	2,741.5	-94.7	23.5	576,112.50	584,976.77	32° 35' 1.346 N	104° 11' 29.944 W
Start 2480.3 hold at 2750.0 MD									
2,800.0	15.00	166.07	2,789.8	-107.3	26.6	576,099.94	584,979.88	32° 35' 1.222 N	104° 11' 29.908 W
2,900.0	15.00	166.07	2,886.4	-132.4	32.8	576,074.82	584,986.11	32° 35' 0.973 N	104° 11' 29.836 W
3,000.0	15.00	166.07	2,982.9	-157.5	39.1	576,049.69	584,992.34	32° 35' 0.725 N	104° 11' 29.763 W
3,100.0	15.00	166.07	3,079.5	-182.7	45.3	576,024.57	584,998.57	32° 35' 0.476 N	104° 11' 29.691 W
3,200.0	15.00	166.07	3,176.1	-207.8	51.5	575,999.45	585,004.80	32° 35' 0.227 N	104° 11' 29.619 W
3,300.0	15.00	166.07	3,272.7	-232.9	57.8	575,974.33	585,011.03	32° 34' 59.979 N	104° 11' 29.546 W
3,400.0	15.00	166.07	3,369.3	-258.0	64.0	575,949.21	585,017.26	32° 34' 59.730 N	104° 11' 29.474 W
3,500.0	15.00	166.07	3,465.9	-283.2	70.2	575,924.09	585,023.49	32° 34' 59.481 N	104° 11' 29.401 W
3,600.0	15.00	166.07	3,562.5	-308.3	76.4	575,898.97	585,029.72	32° 34' 59.233 N	104° 11' 29.329 W
3,700.0	15.00	166.07	3,659.1	-333.4	82.7	575,873.85	585,035.95	32° 34' 58.984 N	104° 11' 29.256 W
3,800.0	15.00	166.07	3,755.7	-358.5	88.9	575,848.73	585,042.18	32° 34' 58.735 N	104° 11' 29.184 W
3,900.0	15.00	166.07	3,852.3	-383.6	95.1	575,823.61	585,048.41	32° 34' 58.487 N	104° 11' 29.112 W
4,000.0	15.00	166.07	3,948.9	-408.8	101.4	575,798.48	585,054.64	32° 34' 58.238 N	104° 11' 29.039 W
4,100.0	15.00	166.07	4,045.5	-433.9	107.6	575,773.36	585,060.86	32° 34' 57.989 N	104° 11' 28.967 W
4,200.0	15.00	166.07	4,142.1	-459.0	113.8	575,748.24	585,067.09	32° 34' 57.741 N	104° 11' 28.894 W
4,300.0	15.00	166.07	4,238.6	-484.1	120.1	575,723.12	585,073.32	32° 34' 57.492 N	104° 11' 28.822 W
4,400.0	15.00	166.07	4,335.2	-509.2	126.3	575,698.00	585,079.55	32° 34' 57.243 N	104° 11' 28.750 W
4,500.0	15.00	166.07	4,431.8	-534.4	132.5	575,672.88	585,085.78	32° 34' 56.995 N	104° 11' 28.677 W
4,600.0	15.00	166.07	4,528.4	-559.5	138.7	575,647.76	585,092.01	32° 34' 56.746 N	104° 11' 28.605 W
4,700.0	15.00	166.07	4,625.0	-584.6	145.0	575,622.64	585,098.24	32° 34' 56.497 N	104° 11' 28.532 W
4,800.0	15.00	166.07	4,721.6	-609.7	151.2	575,597.52	585,104.47	32° 34' 56.249 N	104° 11' 28.460 W
4,900.0	15.00	166.07	4,818.2	-634.8	157.4	575,572.39	585,110.70	32° 34' 56.000 N	104° 11' 28.387 W
5,000.0	15.00	166.07	4,914.8	-660.0	163.7	575,547.27	585,116.93	32° 34' 55.751 N	104° 11' 28.315 W

Planning Report - Geographic

Database:	Compass_17	Local Co-ordinate Reference:	Well KOALA 9 FED COM 124H
Company:	NEW MEXICO	TVD Reference:	KB @ 3304.0usft
Project:	(SP) EDDY	MD Reference:	KB @ 3304.0usft
Site:	KOALA FED	North Reference:	Grid
Well:	KOALA 9 FED COM 124H	Survey Calculation Method:	Minimum Curvature
Wellbore:	OWB		
Design:	PWPO		

Planned Survey									
Measured Depth (usft)	Inclination (°)	Azimuth (°)	Vertical Depth (usft)	+N/-S (usft)	+E/-W (usft)	Map Northing (usft)	Map Easting (usft)	Latitude	Longitude
5,100.0	15.00	166.07	5,011.4	-685.1	169.9	575,522.15	585,123.16	32° 34' 55.503 N	104° 11' 28.243 W
5,200.0	15.00	166.07	5,108.0	-710.2	176.1	575,497.03	585,129.39	32° 34' 55.254 N	104° 11' 28.170 W
5,230.3	15.00	166.07	5,137.3	-717.8	178.0	575,489.41	585,131.28	32° 34' 55.179 N	104° 11' 28.148 W
Start Drop -2.00									
5,300.0	13.61	166.07	5,204.8	-734.5	182.1	575,472.71	585,135.42	32° 34' 55.013 N	104° 11' 28.100 W
5,400.0	11.61	166.07	5,302.4	-755.7	187.4	575,451.52	585,140.67	32° 34' 54.804 N	104° 11' 28.039 W
5,500.0	9.61	166.07	5,400.7	-773.6	191.8	575,433.66	585,145.10	32° 34' 54.627 N	104° 11' 27.988 W
5,600.0	7.61	166.07	5,499.5	-788.1	195.4	575,419.13	585,148.71	32° 34' 54.483 N	104° 11' 27.946 W
5,700.0	5.61	166.07	5,598.9	-799.3	198.2	575,407.97	585,151.47	32° 34' 54.372 N	104° 11' 27.913 W
5,800.0	3.61	166.07	5,698.5	-807.1	200.1	575,400.17	585,153.41	32° 34' 54.295 N	104° 11' 27.891 W
5,900.0	1.61	166.07	5,798.4	-811.5	201.2	575,395.76	585,154.50	32° 34' 54.252 N	104° 11' 27.878 W
5,980.3	0.00	0.00	5,878.8	-812.6	201.5	575,394.66	585,154.77	32° 34' 54.241 N	104° 11' 27.875 W
Start 972.7 hold at 5980.3 MD									
6,000.0	0.00	0.00	5,898.4	-812.6	201.5	575,394.66	585,154.77	32° 34' 54.241 N	104° 11' 27.875 W
6,100.0	0.00	0.00	5,998.4	-812.6	201.5	575,394.66	585,154.77	32° 34' 54.241 N	104° 11' 27.875 W
6,200.0	0.00	0.00	6,098.4	-812.6	201.5	575,394.66	585,154.77	32° 34' 54.241 N	104° 11' 27.875 W
6,300.0	0.00	0.00	6,198.4	-812.6	201.5	575,394.66	585,154.77	32° 34' 54.241 N	104° 11' 27.875 W
6,400.0	0.00	0.00	6,298.4	-812.6	201.5	575,394.66	585,154.77	32° 34' 54.241 N	104° 11' 27.875 W
6,500.0	0.00	0.00	6,398.4	-812.6	201.5	575,394.66	585,154.77	32° 34' 54.241 N	104° 11' 27.875 W
6,600.0	0.00	0.00	6,498.4	-812.6	201.5	575,394.66	585,154.77	32° 34' 54.241 N	104° 11' 27.875 W
6,700.0	0.00	0.00	6,598.4	-812.6	201.5	575,394.66	585,154.77	32° 34' 54.241 N	104° 11' 27.875 W
6,800.0	0.00	0.00	6,698.4	-812.6	201.5	575,394.66	585,154.77	32° 34' 54.241 N	104° 11' 27.875 W
6,900.0	0.00	0.00	6,798.4	-812.6	201.5	575,394.66	585,154.77	32° 34' 54.241 N	104° 11' 27.875 W
6,953.1	0.00	0.00	6,851.5	-812.6	201.5	575,394.66	585,154.77	32° 34' 54.241 N	104° 11' 27.875 W
Start DLS 12.00 TFO 89.62									
6,975.0	2.63	89.62	6,873.4	-812.6	202.0	575,394.67	585,155.28	32° 34' 54.241 N	104° 11' 27.869 W
7,000.0	5.63	89.62	6,898.3	-812.6	203.8	575,394.68	585,157.08	32° 34' 54.241 N	104° 11' 27.848 W
7,025.0	8.63	89.62	6,923.1	-812.5	206.9	575,394.70	585,160.18	32° 34' 54.241 N	104° 11' 27.812 W
7,050.0	11.63	89.62	6,947.7	-812.5	211.3	575,394.73	585,164.57	32° 34' 54.241 N	104° 11' 27.761 W
7,075.0	14.63	89.62	6,972.1	-812.5	217.0	575,394.76	585,170.25	32° 34' 54.242 N	104° 11' 27.694 W
7,100.0	17.63	89.62	6,996.1	-812.4	223.9	575,394.81	585,177.20	32° 34' 54.242 N	104° 11' 27.613 W
7,125.0	20.63	89.62	7,019.7	-812.4	232.1	575,394.86	585,185.39	32° 34' 54.242 N	104° 11' 27.517 W
7,150.0	23.63	89.62	7,042.9	-812.3	241.5	575,394.93	585,194.80	32° 34' 54.243 N	104° 11' 27.407 W
7,175.0	26.63	89.62	7,065.5	-812.2	252.1	575,395.00	585,205.42	32° 34' 54.243 N	104° 11' 27.283 W
7,200.0	29.63	89.62	7,087.5	-812.2	263.9	575,395.07	585,217.20	32° 34' 54.244 N	104° 11' 27.145 W
7,225.0	32.63	89.62	7,108.9	-812.1	276.9	575,395.16	585,230.13	32° 34' 54.245 N	104° 11' 26.994 W
7,250.0	35.63	89.62	7,129.6	-812.0	290.9	575,395.25	585,244.15	32° 34' 54.245 N	104° 11' 26.830 W
7,275.0	38.63	89.62	7,149.6	-811.9	306.0	575,395.35	585,259.24	32° 34' 54.246 N	104° 11' 26.654 W
7,300.0	41.63	89.62	7,168.7	-811.8	322.1	575,395.45	585,275.35	32° 34' 54.247 N	104° 11' 26.466 W
7,325.0	44.63	89.62	7,186.9	-811.7	339.2	575,395.57	585,292.44	32° 34' 54.248 N	104° 11' 26.266 W
7,350.0	47.63	89.62	7,204.2	-811.6	357.2	575,395.69	585,310.46	32° 34' 54.249 N	104° 11' 26.055 W
7,375.0	50.63	89.62	7,220.6	-811.4	376.1	575,395.81	585,329.36	32° 34' 54.250 N	104° 11' 25.835 W
7,400.0	53.63	89.62	7,236.0	-811.3	395.8	575,395.94	585,349.09	32° 34' 54.251 N	104° 11' 25.604 W
7,425.0	56.63	89.62	7,250.2	-811.2	416.3	575,396.07	585,369.60	32° 34' 54.252 N	104° 11' 25.364 W
7,450.0	59.63	89.62	7,263.4	-811.0	437.6	575,396.21	585,390.83	32° 34' 54.253 N	104° 11' 25.116 W
7,475.0	62.63	89.62	7,275.5	-810.9	459.4	575,396.36	585,412.72	32° 34' 54.254 N	104° 11' 24.860 W
7,500.0	65.63	89.62	7,286.4	-810.7	481.9	575,396.51	585,435.21	32° 34' 54.255 N	104° 11' 24.597 W
7,525.0	68.63	89.62	7,296.1	-810.6	505.0	575,396.66	585,458.24	32° 34' 54.256 N	104° 11' 24.328 W
7,550.0	71.63	89.62	7,304.6	-810.4	528.5	575,396.81	585,481.75	32° 34' 54.258 N	104° 11' 24.053 W
7,575.0	74.63	89.62	7,311.9	-810.3	552.4	575,396.97	585,505.67	32° 34' 54.259 N	104° 11' 23.774 W
7,600.0	77.63	89.62	7,317.9	-810.1	576.7	575,397.13	585,529.94	32° 34' 54.260 N	104° 11' 23.490 W
7,625.0	80.63	89.62	7,322.6	-810.0	601.2	575,397.29	585,554.49	32° 34' 54.261 N	104° 11' 23.203 W
7,650.0	83.63	89.62	7,326.0	-809.8	626.0	575,397.45	585,579.25	32° 34' 54.263 N	104° 11' 22.914 W
7,675.0	86.63	89.62	7,328.1	-809.6	650.9	575,397.61	585,604.15	32° 34' 54.264 N	104° 11' 22.623 W

Planning Report - Geographic

Database:	Compass_17	Local Co-ordinate Reference:	Well KOALA 9 FED COM 124H
Company:	NEW MEXICO	TVD Reference:	KB @ 3304.0usft
Project:	(SP) EDDY	MD Reference:	KB @ 3304.0usft
Site:	KOALA FED	North Reference:	Grid
Well:	KOALA 9 FED COM 124H	Survey Calculation Method:	Minimum Curvature
Wellbore:	OWB		
Design:	PWPO		

Planned Survey										
Measured Depth (usft)	Inclination (°)	Azimuth (°)	Vertical Depth (usft)	+N/-S (usft)	+E/-W (usft)	Map Northing (usft)	Map Easting (usft)	Latitude	Longitude	
7,700.0	89.63	89.62	7,329.0	-809.5	675.9	575,397.78	585,629.14	32° 34' 54.265 N	104° 11' 22.331 W	
7,703.1	90.00	89.62	7,329.0	-809.4	679.0	575,397.80	585,632.23	32° 34' 54.265 N	104° 11' 22.295 W	
Start 10115.9 hold at 7703.1 MD										
7,800.0	90.00	89.62	7,329.0	-808.8	775.9	575,398.44	585,729.13	32° 34' 54.270 N	104° 11' 21.162 W	
7,900.0	90.00	89.62	7,329.0	-808.1	875.9	575,399.09	585,829.13	32° 34' 54.276 N	104° 11' 19.993 W	
8,000.0	90.00	89.62	7,329.0	-807.5	975.9	575,399.75	585,929.13	32° 34' 54.281 N	104° 11' 18.825 W	
8,100.0	90.00	89.62	7,329.0	-806.8	1,075.9	575,400.41	586,029.13	32° 34' 54.286 N	104° 11' 17.656 W	
8,200.0	90.00	89.62	7,329.0	-806.2	1,175.9	575,401.06	586,129.13	32° 34' 54.291 N	104° 11' 16.487 W	
8,300.0	90.00	89.62	7,329.0	-805.5	1,275.8	575,401.72	586,229.12	32° 34' 54.296 N	104° 11' 15.318 W	
8,400.0	90.00	89.62	7,329.0	-804.9	1,375.8	575,402.38	586,329.12	32° 34' 54.301 N	104° 11' 14.150 W	
8,500.0	90.00	89.62	7,329.0	-804.2	1,475.8	575,403.03	586,429.12	32° 34' 54.307 N	104° 11' 12.981 W	
8,600.0	90.00	89.62	7,329.0	-803.6	1,575.8	575,403.69	586,529.12	32° 34' 54.312 N	104° 11' 11.812 W	
8,700.0	90.00	89.62	7,329.0	-802.9	1,675.8	575,404.35	586,629.11	32° 34' 54.317 N	104° 11' 10.643 W	
8,800.0	90.00	89.62	7,329.0	-802.2	1,775.8	575,405.01	586,729.11	32° 34' 54.322 N	104° 11' 9.475 W	
8,900.0	90.00	89.62	7,329.0	-801.6	1,875.8	575,405.66	586,829.11	32° 34' 54.327 N	104° 11' 8.306 W	
9,000.0	90.00	89.62	7,329.0	-800.9	1,975.8	575,406.32	586,929.11	32° 34' 54.332 N	104° 11' 7.137 W	
9,100.0	90.00	89.62	7,329.0	-800.3	2,075.8	575,406.98	587,029.11	32° 34' 54.337 N	104° 11' 5.968 W	
9,200.0	90.00	89.62	7,329.0	-799.6	2,175.8	575,407.63	587,129.10	32° 34' 54.342 N	104° 11' 4.799 W	
9,300.0	90.00	89.62	7,329.0	-799.0	2,275.8	575,408.29	587,229.10	32° 34' 54.348 N	104° 11' 3.631 W	
9,400.0	90.00	89.62	7,329.0	-798.3	2,375.8	575,408.95	587,329.10	32° 34' 54.353 N	104° 11' 2.462 W	
9,500.0	90.00	89.62	7,329.0	-797.6	2,475.8	575,409.60	587,429.10	32° 34' 54.358 N	104° 11' 1.293 W	
9,600.0	90.00	89.62	7,329.0	-797.0	2,575.8	575,410.26	587,529.09	32° 34' 54.363 N	104° 11' 0.124 W	
9,700.0	90.00	89.62	7,329.0	-796.3	2,675.8	575,410.92	587,629.09	32° 34' 54.368 N	104° 10' 58.956 W	
9,800.0	90.00	89.62	7,329.0	-795.7	2,775.8	575,411.57	587,729.09	32° 34' 54.373 N	104° 10' 57.787 W	
9,900.0	90.00	89.62	7,329.0	-795.0	2,875.8	575,412.23	587,829.09	32° 34' 54.378 N	104° 10' 56.618 W	
10,000.0	90.00	89.62	7,329.0	-794.4	2,975.8	575,412.89	587,929.09	32° 34' 54.383 N	104° 10' 55.449 W	
10,100.0	90.00	89.62	7,329.0	-793.7	3,075.8	575,413.55	588,029.08	32° 34' 54.388 N	104° 10' 54.281 W	
10,200.0	90.00	89.62	7,329.0	-793.0	3,175.8	575,414.20	588,129.08	32° 34' 54.393 N	104° 10' 53.112 W	
10,300.0	90.00	89.62	7,329.0	-792.4	3,275.8	575,414.86	588,229.08	32° 34' 54.399 N	104° 10' 51.943 W	
10,400.0	90.00	89.62	7,329.0	-791.7	3,375.8	575,415.52	588,329.08	32° 34' 54.404 N	104° 10' 50.774 W	
10,500.0	90.00	89.62	7,329.0	-791.1	3,475.8	575,416.17	588,429.08	32° 34' 54.409 N	104° 10' 49.606 W	
10,600.0	90.00	89.62	7,329.0	-790.4	3,575.8	575,416.83	588,529.07	32° 34' 54.414 N	104° 10' 48.437 W	
10,700.0	90.00	89.62	7,329.0	-789.8	3,675.8	575,417.49	588,629.07	32° 34' 54.419 N	104° 10' 47.268 W	
10,800.0	90.00	89.62	7,329.0	-789.1	3,775.8	575,418.14	588,729.07	32° 34' 54.424 N	104° 10' 46.099 W	
10,900.0	90.00	89.62	7,329.0	-788.4	3,875.8	575,418.80	588,829.07	32° 34' 54.429 N	104° 10' 44.931 W	
11,000.0	90.00	89.62	7,329.0	-787.8	3,975.8	575,419.46	588,929.06	32° 34' 54.434 N	104° 10' 43.762 W	
11,100.0	90.00	89.62	7,329.0	-787.1	4,075.8	575,420.11	589,029.06	32° 34' 54.439 N	104° 10' 42.593 W	
11,200.0	90.00	89.62	7,329.0	-786.5	4,175.8	575,420.77	589,129.06	32° 34' 54.444 N	104° 10' 41.424 W	
11,300.0	90.00	89.62	7,329.0	-785.8	4,275.8	575,421.43	589,229.06	32° 34' 54.449 N	104° 10' 40.256 W	
11,400.0	90.00	89.62	7,329.0	-785.2	4,375.8	575,422.09	589,329.06	32° 34' 54.454 N	104° 10' 39.087 W	
11,500.0	90.00	89.62	7,329.0	-784.5	4,475.8	575,422.74	589,429.05	32° 34' 54.459 N	104° 10' 37.918 W	
11,600.0	90.00	89.62	7,329.0	-783.8	4,575.8	575,423.40	589,529.05	32° 34' 54.464 N	104° 10' 36.749 W	
11,700.0	90.00	89.62	7,329.0	-783.2	4,675.8	575,424.06	589,629.05	32° 34' 54.469 N	104° 10' 35.581 W	
11,800.0	90.00	89.62	7,329.0	-782.5	4,775.8	575,424.71	589,729.05	32° 34' 54.474 N	104° 10' 34.412 W	
11,900.0	90.00	89.62	7,329.0	-781.9	4,875.8	575,425.37	589,829.05	32° 34' 54.480 N	104° 10' 33.243 W	
12,000.0	90.00	89.62	7,329.0	-781.2	4,975.8	575,426.03	589,929.04	32° 34' 54.485 N	104° 10' 32.074 W	
12,100.0	90.00	89.62	7,329.0	-780.6	5,075.8	575,426.68	590,029.04	32° 34' 54.490 N	104° 10' 30.906 W	
12,200.0	90.00	89.62	7,329.0	-779.9	5,175.8	575,427.34	590,129.04	32° 34' 54.495 N	104° 10' 29.737 W	
12,300.0	90.00	89.62	7,329.0	-779.2	5,275.8	575,428.00	590,229.04	32° 34' 54.500 N	104° 10' 28.568 W	
12,400.0	90.00	89.62	7,329.0	-778.6	5,375.8	575,428.65	590,329.03	32° 34' 54.505 N	104° 10' 27.399 W	
12,500.0	90.00	89.62	7,329.0	-777.9	5,475.8	575,429.31	590,429.03	32° 34' 54.510 N	104° 10' 26.231 W	
12,600.0	90.00	89.62	7,329.0	-777.3	5,575.8	575,429.97	590,529.03	32° 34' 54.515 N	104° 10' 25.062 W	
12,700.0	90.00	89.62	7,329.0	-776.6	5,675.8	575,430.63	590,629.03	32° 34' 54.520 N	104° 10' 23.893 W	
12,800.0	90.00	89.62	7,329.0	-776.0	5,775.8	575,431.28	590,729.03	32° 34' 54.525 N	104° 10' 22.724 W	

Planning Report - Geographic

Database:	Compass_17	Local Co-ordinate Reference:	Well KOALA 9 FED COM 124H
Company:	NEW MEXICO	TVD Reference:	KB @ 3304.0usft
Project:	(SP) EDDY	MD Reference:	KB @ 3304.0usft
Site:	KOALA FED	North Reference:	Grid
Well:	KOALA 9 FED COM 124H	Survey Calculation Method:	Minimum Curvature
Wellbore:	OWB		
Design:	PWPO		

Planned Survey										
Measured Depth (usft)	Inclination (°)	Azimuth (°)	Vertical Depth (usft)	+N/-S (usft)	+E/-W (usft)	Map Northing (usft)	Map Easting (usft)	Latitude	Longitude	
12,900.0	90.00	89.62	7,329.0	-775.3	5,875.8	575,431.94	590,829.02	32° 34' 54.530 N	104° 10' 21.555 W	
13,000.0	90.00	89.62	7,329.0	-774.6	5,975.7	575,432.60	590,929.02	32° 34' 54.535 N	104° 10' 20.387 W	
13,100.0	90.00	89.62	7,329.0	-774.0	6,075.7	575,433.25	591,029.02	32° 34' 54.540 N	104° 10' 19.218 W	
13,200.0	90.00	89.62	7,329.0	-773.3	6,175.7	575,433.91	591,129.02	32° 34' 54.545 N	104° 10' 18.049 W	
13,300.0	90.00	89.62	7,329.0	-772.7	6,275.7	575,434.57	591,229.02	32° 34' 54.550 N	104° 10' 16.880 W	
13,400.0	90.00	89.62	7,329.0	-772.0	6,375.7	575,435.22	591,329.01	32° 34' 54.555 N	104° 10' 15.712 W	
13,500.0	90.00	89.62	7,329.0	-771.4	6,475.7	575,435.88	591,429.01	32° 34' 54.560 N	104° 10' 14.543 W	
13,600.0	90.00	89.62	7,329.0	-770.7	6,575.7	575,436.54	591,529.01	32° 34' 54.565 N	104° 10' 13.374 W	
13,700.0	90.00	89.62	7,329.0	-770.0	6,675.7	575,437.19	591,629.01	32° 34' 54.570 N	104° 10' 12.205 W	
13,800.0	90.00	89.62	7,329.0	-769.4	6,775.7	575,437.85	591,729.00	32° 34' 54.575 N	104° 10' 11.037 W	
13,900.0	90.00	89.62	7,329.0	-768.7	6,875.7	575,438.51	591,829.00	32° 34' 54.580 N	104° 10' 9.868 W	
14,000.0	90.00	89.62	7,329.0	-768.1	6,975.7	575,439.17	591,929.00	32° 34' 54.585 N	104° 10' 8.699 W	
14,100.0	90.00	89.62	7,329.0	-767.4	7,075.7	575,439.82	592,029.00	32° 34' 54.590 N	104° 10' 7.530 W	
14,200.0	90.00	89.62	7,329.0	-766.8	7,175.7	575,440.48	592,129.00	32° 34' 54.595 N	104° 10' 6.362 W	
14,300.0	90.00	89.62	7,329.0	-766.1	7,275.7	575,441.14	592,228.99	32° 34' 54.600 N	104° 10' 5.193 W	
14,400.0	90.00	89.62	7,329.0	-765.4	7,375.7	575,441.79	592,328.99	32° 34' 54.604 N	104° 10' 4.024 W	
14,500.0	90.00	89.62	7,329.0	-764.8	7,475.7	575,442.45	592,428.99	32° 34' 54.609 N	104° 10' 2.855 W	
14,600.0	90.00	89.62	7,329.0	-764.1	7,575.7	575,443.11	592,528.99	32° 34' 54.614 N	104° 10' 1.687 W	
14,700.0	90.00	89.62	7,329.0	-763.5	7,675.7	575,443.76	592,628.99	32° 34' 54.619 N	104° 10' 0.518 W	
14,800.0	90.00	89.62	7,329.0	-762.8	7,775.7	575,444.42	592,728.98	32° 34' 54.624 N	104° 9' 59.349 W	
14,900.0	90.00	89.62	7,329.0	-762.2	7,875.7	575,445.08	592,828.98	32° 34' 54.629 N	104° 9' 58.180 W	
15,000.0	90.00	89.62	7,329.0	-761.5	7,975.7	575,445.73	592,928.98	32° 34' 54.634 N	104° 9' 57.012 W	
15,100.0	90.00	89.62	7,329.0	-760.9	8,075.7	575,446.39	593,028.98	32° 34' 54.639 N	104° 9' 55.843 W	
15,200.0	90.00	89.62	7,329.0	-760.2	8,175.7	575,447.05	593,128.97	32° 34' 54.644 N	104° 9' 54.674 W	
15,300.0	90.00	89.62	7,329.0	-759.5	8,275.7	575,447.71	593,228.97	32° 34' 54.649 N	104° 9' 53.505 W	
15,400.0	90.00	89.62	7,329.0	-758.9	8,375.7	575,448.36	593,328.97	32° 34' 54.654 N	104° 9' 52.337 W	
15,500.0	90.00	89.62	7,329.0	-758.2	8,475.7	575,449.02	593,428.97	32° 34' 54.659 N	104° 9' 51.168 W	
15,600.0	90.00	89.62	7,329.0	-757.6	8,575.7	575,449.68	593,528.97	32° 34' 54.664 N	104° 9' 49.999 W	
15,700.0	90.00	89.62	7,329.0	-756.9	8,675.7	575,450.33	593,628.96	32° 34' 54.669 N	104° 9' 48.830 W	
15,800.0	90.00	89.62	7,329.0	-756.3	8,775.7	575,450.99	593,728.96	32° 34' 54.674 N	104° 9' 47.662 W	
15,900.0	90.00	89.62	7,329.0	-755.6	8,875.7	575,451.65	593,828.96	32° 34' 54.679 N	104° 9' 46.493 W	
16,000.0	90.00	89.62	7,329.0	-754.9	8,975.7	575,452.30	593,928.96	32° 34' 54.683 N	104° 9' 45.324 W	
16,100.0	90.00	89.62	7,329.0	-754.3	9,075.7	575,452.96	594,028.95	32° 34' 54.688 N	104° 9' 44.155 W	
16,200.0	90.00	89.62	7,329.0	-753.6	9,175.7	575,453.62	594,128.95	32° 34' 54.693 N	104° 9' 42.986 W	
16,300.0	90.00	89.62	7,329.0	-753.0	9,275.7	575,454.27	594,228.95	32° 34' 54.698 N	104° 9' 41.818 W	
16,400.0	90.00	89.62	7,329.0	-752.3	9,375.7	575,454.93	594,328.95	32° 34' 54.703 N	104° 9' 40.649 W	
16,500.0	90.00	89.62	7,329.0	-751.7	9,475.7	575,455.59	594,428.95	32° 34' 54.708 N	104° 9' 39.480 W	
16,600.0	90.00	89.62	7,329.0	-751.0	9,575.7	575,456.25	594,528.94	32° 34' 54.713 N	104° 9' 38.311 W	
16,700.0	90.00	89.62	7,329.0	-750.3	9,675.7	575,456.90	594,628.94	32° 34' 54.718 N	104° 9' 37.143 W	
16,800.0	90.00	89.62	7,329.0	-749.7	9,775.7	575,457.56	594,728.94	32° 34' 54.723 N	104° 9' 35.974 W	
16,900.0	90.00	89.62	7,329.0	-749.0	9,875.7	575,458.22	594,828.94	32° 34' 54.728 N	104° 9' 34.805 W	
17,000.0	90.00	89.62	7,329.0	-748.4	9,975.7	575,458.87	594,928.94	32° 34' 54.732 N	104° 9' 33.636 W	
17,100.0	90.00	89.62	7,329.0	-747.7	10,075.7	575,459.53	595,028.93	32° 34' 54.737 N	104° 9' 32.468 W	
17,200.0	90.00	89.62	7,329.0	-747.1	10,175.7	575,460.19	595,128.93	32° 34' 54.742 N	104° 9' 31.299 W	
17,300.0	90.00	89.62	7,329.0	-746.4	10,275.7	575,460.84	595,228.93	32° 34' 54.747 N	104° 9' 30.130 W	
17,400.0	90.00	89.62	7,329.0	-745.7	10,375.7	575,461.50	595,328.93	32° 34' 54.752 N	104° 9' 28.961 W	
17,500.0	90.00	89.62	7,329.0	-745.1	10,475.7	575,462.16	595,428.92	32° 34' 54.757 N	104° 9' 27.793 W	
17,600.0	90.00	89.62	7,329.0	-744.4	10,575.6	575,462.81	595,528.92	32° 34' 54.762 N	104° 9' 26.624 W	
17,700.0	90.00	89.62	7,329.0	-743.8	10,675.6	575,463.47	595,628.92	32° 34' 54.767 N	104° 9' 25.455 W	
17,800.0	90.00	89.62	7,329.0	-743.1	10,775.6	575,464.13	595,728.92	32° 34' 54.771 N	104° 9' 24.286 W	
17,819.0	90.00	89.62	7,329.0	-743.0	10,794.6	575,464.25	595,747.89	32° 34' 54.772 N	104° 9' 24.065 W	
TD at 17819.0										

Planning Report - Geographic

Database:	Compass_17	Local Co-ordinate Reference:	Well KOALA 9 FED COM 124H
Company:	NEW MEXICO	TVD Reference:	KB @ 3304.0usft
Project:	(SP) EDDY	MD Reference:	KB @ 3304.0usft
Site:	KOALA FED	North Reference:	Grid
Well:	KOALA 9 FED COM 124H	Survey Calculation Method:	Minimum Curvature
Wellbore:	OWB		
Design:	PWP0		

Design Targets									
Target Name	Dip Angle	Dip Dir.	TVD	+N/-S	+E/-W	Northing	Easting	Latitude	Longitude
- hit/miss target	(°)	(°)	(usft)	(usft)	(usft)	(usft)	(usft)		
- Shape									
PP3 KOALA 9 FED C - plan misses target center by 1.8usft at 11177.2usft MD (7329.0 TVD, -786.6 N, 4153.0 E) - Point	0.00	0.00	7,329.0	-788.4	4,153.0	575,418.86	589,106.31	32° 34' 54.426 N	104° 10' 41.690 W
BHL KOALA 9 FED C - plan hits target center - Point	0.00	0.00	7,329.0	-743.0	10,794.6	575,464.25	595,747.89	32° 34' 54.772 N	104° 9' 24.065 W
FTP KOALA 9 FED C - plan misses target center by 163.5usft at 7351.7usft MD (7205.4 TVD, -811.5 N, 358.4 E) - Point	0.00	0.00	7,329.0	-812.6	251.5	575,394.66	585,204.76	32° 34' 54.240 N	104° 11' 27.291 W
LTP KOALA 9 FED C - plan hits target center - Point	0.00	0.00	7,329.0	-743.6	10,704.6	575,463.61	595,657.87	32° 34' 54.767 N	104° 9' 25.117 W
PP4 KOALA 9 FED C - plan misses target center by 2.2usft at 12511.3usft MD (7329.0 TVD, -777.9 N, 5487.1 E) - Point	0.00	0.00	7,329.0	-780.1	5,487.1	575,427.14	590,440.36	32° 34' 54.488 N	104° 10' 26.098 W
PP2 KOALA 9 FED C - plan misses target center by 1.3usft at 9843.1usft MD (7329.0 TVD, -795.4 N, 2818.9 E) - Point	0.00	0.00	7,329.0	-796.6	2,818.9	575,410.59	587,772.17	32° 34' 54.363 N	104° 10' 57.283 W

Formations						
Measured Depth (usft)	Vertical Depth (usft)	Name	Lithology	Dip (°)	Dip Direction (°)	
227.0	227.0	Rustler				
368.0	368.0	Salado = T/Salt				
704.0	704.0	Tansill				
779.0	779.0	Yates				
1,154.0	1,154.0	Seven Rivers				
1,824.0	1,824.0	Queen				
2,054.0	2,054.0	Grayburg				
2,405.4	2,404.0	San Andres				
2,506.6	2,504.0	Capitan (if applicable)				
2,995.9	2,979.0	Delaware Sands = CYCN				
3,384.1	3,354.0	BYCN				
4,730.0	4,654.0	Bone Spring = BSG				
6,205.6	6,104.0	FBSG				
7,280.7	7,154.0	SBSG				

Planning Report - Geographic

Database:	Compass_17	Local Co-ordinate Reference:	Well KOALA 9 FED COM 124H
Company:	NEW MEXICO	TVD Reference:	KB @ 3304.0usft
Project:	(SP) EDDY	MD Reference:	KB @ 3304.0usft
Site:	KOALA FED	North Reference:	Grid
Well:	KOALA 9 FED COM 124H	Survey Calculation Method:	Minimum Curvature
Wellbore:	OWB		
Design:	PWP0		

Plan Annotations

Measured Depth (usft)	Vertical Depth (usft)	Local Coordinates		Comment
		+N/-S (usft)	+E/-W (usft)	
2,000.0	2,000.0	0.0	0.0	Start Build 2.00
2,750.0	2,741.5	-94.7	23.5	Start 2480.3 hold at 2750.0 MD
5,230.3	5,137.3	-717.8	178.0	Start Drop -2.00
5,980.3	5,878.8	-812.6	201.5	Start 972.7 hold at 5980.3 MD
6,953.1	6,851.5	-812.6	201.5	Start DLS 12.00 TFO 89.62
7,703.1	7,329.0	-809.4	679.0	Start 10115.9 hold at 7703.1 MD
17,819.0	7,329.0	-743.0	10,794.6	TD at 17819.0

Project: (SP) EDDY
 Site: KOALA FED
 Well: KOALA 9 FED COM 124H
 Wellbore: OWB
 Design: PWPO

SECTION DETAILS

Sec	MD	Inc	Azi	TVD	+N/-S	+E/-W	Dleg	TFace	VSec	Annotation
1	0.0	0.00	0.00	0.0	0.0	0.0	0.00	0.00	0.0	
2	2000.0	0.00	0.00	2000.0	0.0	0.0	0.00	0.00	0.0	Start Build 2.00
3	2750.0	15.00	166.07	2741.5	-94.7	23.5	2.00	166.07	29.9	Start 2480.3 hold at 2750.0 MD
4	5230.3	15.00	166.07	5137.3	-717.8	178.0	0.00	0.00	226.9	Start Drop -2.00
5	5980.3	0.00	0.00	5878.8	-812.6	201.5	2.00	180.00	256.8	Start 972.7 hold at 5980.3 MD
6	6953.1	0.00	0.00	6851.5	-812.6	201.5	0.00	0.00	256.8	Start DLS 12.00 TFO 89.62
7	7703.1	90.00	89.62	7329.0	-809.4	679.0	12.00	89.62	732.9	Start 10115.9 hold at 7703.1 MD
8	17819.0	90.00	89.62	7329.0	-743.0	10794.6	0.00	0.00	10820.2	TD at 17819.0

DESIGN TARGET DETAILS

Name	TVD	+N/-S	+E/-W	Northing	Eastings	Latitude	Longitude
BHL KOALA 9 FED COM 124H	7329.0	-743.0	10794.6	575464.25	595747.89	32° 34' 54.772 N	104° 9' 24.065 W
FTP KOALA 9 FED COM 124H	7329.0	-743.6	10704.6	575394.66	585204.76	32° 34' 54.240 N	104° 11' 27.291 W
LTP KOALA 9 FED COM 124H	7329.0	-796.6	2818.9	575410.59	595657.87	32° 34' 54.767 N	104° 9' 25.117 W
PP2 KOALA 9 FED COM 124H	7329.0	-788.4	4153.0	575418.86	589706.31	32° 34' 54.426 N	104° 10' 57.283 W
PP4 KOALA 9 FED COM 124H	7329.0	-780.1	5487.1	575427.14	590440.36	32° 34' 54.488 N	104° 10' 26.098 W

WELL DETAILS: KOALA 9 FED COM 124H

Northing	Eastings	Latitude	Longitude
576207.24	584953.27	32° 35' 2.284 N	104° 11' 30.218 W



FORMATION TOP DETAILS

Name	MDPath	TVDPath	Formation
Rustler	227.0	227.0	Formation
Salado = T/Salt Tansill	368.0	368.0	Rustler
Yates	704.0	704.0	Salado = T/Salt Tansill
Seven Rivers	779.0	779.0	Yates
Queen	1154.0	1154.0	Seven Rivers
Grayburg	1824.0	1824.0	Queen
San Andres	2054.0	2054.0	Grayburg
Capitan (if applicable)	2404.0	2404.0	San Andres
Delaware Sands = CYCN BYCN	2504.0	2504.0	Capitan (if applicable)
Bone Spring = BSGL	2979.0	2979.0	Delaware Sands = CYCN BYCN
FBSG	3354.0	3354.0	Bone Spring = BSGL
SBSG	4654.0	4654.0	FBSG
	6104.0	6104.0	SBSG
	7280.7	7154.0	

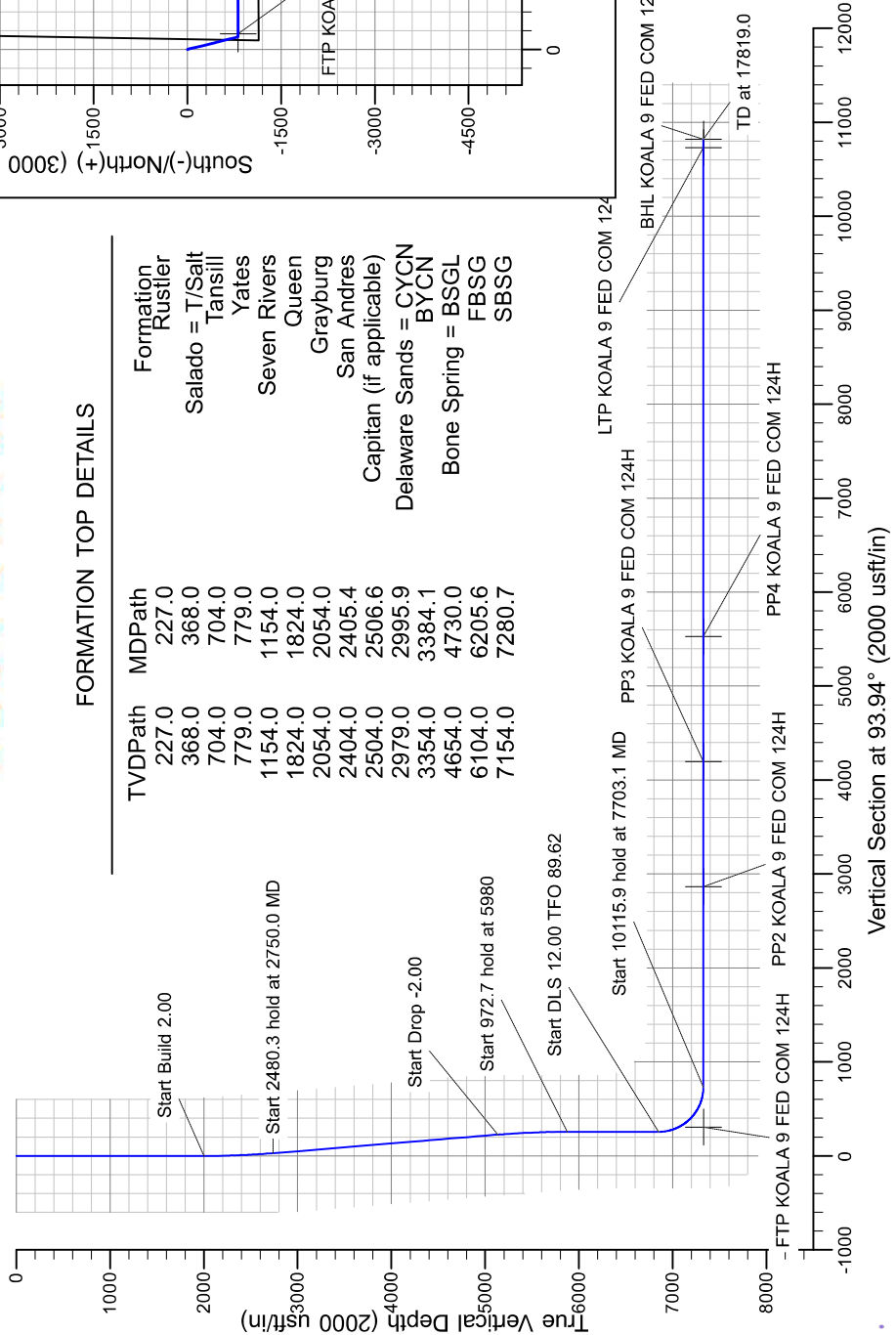
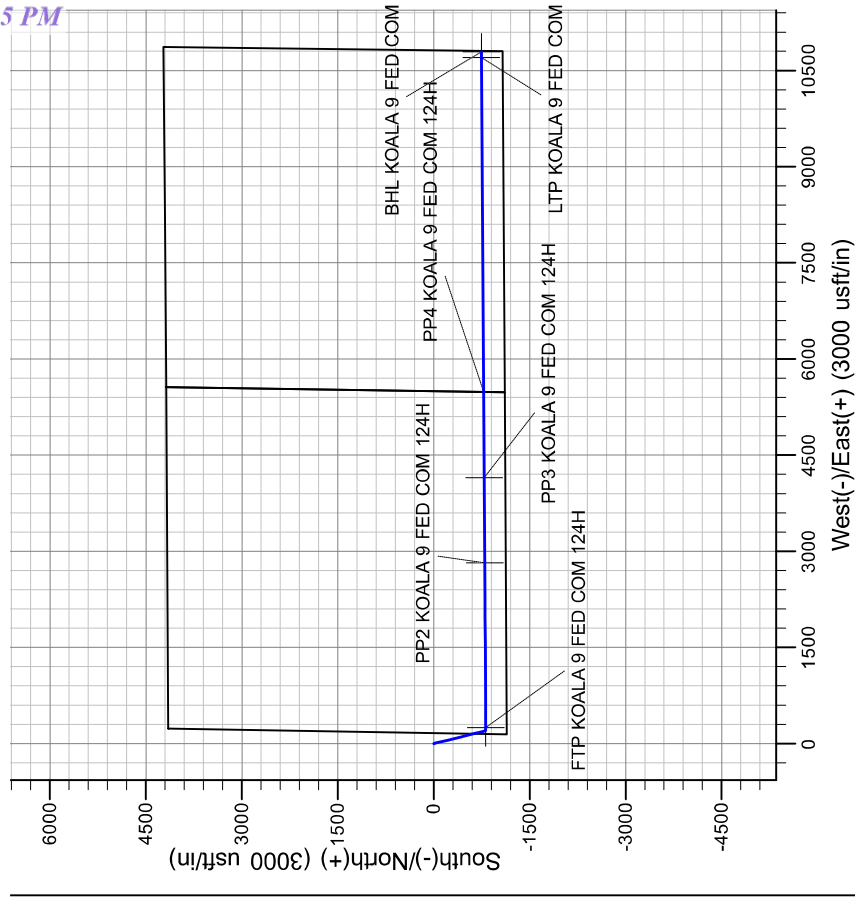

NEW MEXICO

**(SP) EDDY
KOALA FED
KOALA 9 FED COM 124H**

**OWB
PWP0**

Anticollision Report

21 October, 2025

Anticollision Report

Company:	NEW MEXICO	Local Co-ordinate Reference:	Well KOALA 9 FED COM 124H
Project:	(SP) EDDY	TVD Reference:	KB @ 3304.0usft
Reference Site:	KOALA FED	MD Reference:	KB @ 3304.0usft
Site Error:	0.0 usft	North Reference:	Grid
Reference Well:	KOALA 9 FED COM 124H	Survey Calculation Method:	Minimum Curvature
Well Error:	0.0 usft	Output errors are at	2.00 sigma
Reference Wellbore	OWB	Database:	Compass_17
Reference Design:	PWP0	Offset TVD Reference:	Offset Datum

Reference	PWP0		
Filter type:	NO GLOBAL FILTER: Using user defined selection & filtering criteria		
Interpolation Method:	Stations	Error Model:	ISCWSA
Depth Range:	Unlimited	Scan Method:	Closest Approach 3D
Results Limited by:	Maximum centre distance of 1,000.0usft	Error Surface:	Pedal Curve
Warning Levels Evaluated at:	2.00 Sigma	Casing Method:	Not applied

Survey Tool Program	Date	10/21/2025		
From (usft)	To (usft)	Survey (Wellbore)	Tool Name	Description
0.0	17,819.0	PWP0 (OWB)	MWD	OWSG_Rev2_ MWD - Standard

Site Name	Reference Measured Depth (usft)	Offset Measured Depth (usft)	Distance Between Centres (usft)	Distance Between Ellipses (usft)	Separation Factor	Warning
Summary						
Offset Well - Wellbore - Design						
KOALA FED						
KOALA 9 FED COM 111H - OWB - PWP0						Out of range
KOALA 9 FED COM 112H - OWB - PWP0						Out of range
KOALA 9 FED COM 113H - OWB - PWP0	2,000.0	2,000.0	30.0	15.9	2.125	CC
KOALA 9 FED COM 113H - OWB - PWP0	2,100.0	2,099.4	30.6	15.7	2.063	ES, SF
KOALA 9 FED COM 114H - OWB - PWP0	5,930.4	5,930.1	58.6	9.9	1.203	Level 3, CC, ES, SF
KOALA 9 FED COM 131H - OWB - PWP0						Out of range

Offset Design: KOALA FED - KOALA 9 FED COM 113H - OWB - PWP0													Offset Site Error:	0.0 usft
Survey Program: 0-MWD													Offset Well Error:	0.0 usft
Measured Depth (usft)	Vertical Depth (usft)	Measured Depth (usft)	Vertical Depth (usft)	Reference (usft)	Semi Major Axis Offset (usft)	Highside Toolface (°)	Offset Wellbore Centre +N/-S (usft)	+E/-W (usft)	Distance Between Centres (usft)	Distance Between Ellipses (usft)	Minimum Separation (usft)	Separation Factor	Warning	
0.0	0.0	0.0	0.0	0.0	0.0	89.77	0.1	30.0	30.0					
100.0	100.0	100.0	100.0	0.3	0.3	89.77	0.1	30.0	30.0	29.5	0.50	59.798		
200.0	200.0	200.0	200.0	0.6	0.6	89.77	0.1	30.0	30.0	28.8	1.22	24.623		
300.0	300.0	300.0	300.0	1.0	1.0	89.77	0.1	30.0	30.0	28.1	1.94	15.503		
400.0	400.0	400.0	400.0	1.3	1.3	89.77	0.1	30.0	30.0	27.4	2.65	11.313		
423.6	423.6	423.6	423.6	1.4	1.4	89.77	0.1	30.0	30.0	27.2	2.82	10.636		
500.0	500.0	500.0	500.0	1.7	1.7	89.77	0.1	30.0	30.0	26.6	3.37	8.906		
524.1	524.1	524.1	524.1	1.8	1.8	89.77	0.1	30.0	30.0	26.5	3.54	8.471		
600.0	600.0	600.0	600.0	2.0	2.0	89.77	0.1	30.0	30.0	25.9	4.09	7.344		
633.3	633.3	633.3	633.3	2.2	2.2	89.77	0.1	30.0	30.0	25.7	4.33	6.938		
700.0	700.0	700.0	700.0	2.4	2.4	89.77	0.1	30.0	30.0	25.2	4.80	6.248		
800.0	800.0	800.0	800.0	2.8	2.8	89.77	0.1	30.0	30.0	24.5	5.52	5.436		
900.0	900.0	900.0	900.0	3.1	3.1	89.77	0.1	30.0	30.0	23.8	6.24	4.811		
1,000.0	1,000.0	1,000.0	1,000.0	3.5	3.5	89.77	0.1	30.0	30.0	23.1	6.95	4.315		
1,100.0	1,100.0	1,100.0	1,100.0	3.8	3.8	89.77	0.1	30.0	30.0	22.3	7.67	3.912		
1,200.0	1,200.0	1,200.0	1,200.0	4.2	4.2	89.77	0.1	30.0	30.0	21.6	8.39	3.578		
1,300.0	1,300.0	1,300.0	1,300.0	4.6	4.6	89.77	0.1	30.0	30.0	20.9	9.11	3.296		
1,400.0	1,400.0	1,400.0	1,400.0	4.9	4.9	89.77	0.1	30.0	30.0	20.2	9.82	3.055		
1,500.0	1,500.0	1,500.0	1,500.0	5.3	5.3	89.77	0.1	30.0	30.0	19.5	10.54	2.848		
1,600.0	1,600.0	1,600.0	1,600.0	5.6	5.6	89.77	0.1	30.0	30.0	18.8	11.26	2.666		
1,700.0	1,700.0	1,700.0	1,700.0	6.0	6.0	89.77	0.1	30.0	30.0	18.0	11.97	2.507		

CC - Min centre to center distance or convergent point, SF - min separation factor, ES - min ellipse separation

Anticollision Report

Company:	NEW MEXICO	Local Co-ordinate Reference:	Well KOALA 9 FED COM 124H
Project:	(SP) EDDY	TVD Reference:	KB @ 3304.0usft
Reference Site:	KOALA FED	MD Reference:	KB @ 3304.0usft
Site Error:	0.0 usft	North Reference:	Grid
Reference Well:	KOALA 9 FED COM 124H	Survey Calculation Method:	Minimum Curvature
Well Error:	0.0 usft	Output errors are at	2.00 sigma
Reference Wellbore	OWB	Database:	Compass_17
Reference Design:	PWPO	Offset TVD Reference:	Offset Datum

Offset Design: KOALA FED - KOALA 9 FED COM 113H - OWB - PWPO													Offset Site Error:	0.0 usft	
Survey Program: 0-MWD													Offset Well Error:		0.0 usft
Reference	Offset		Semi Major Axis		Highside Toolface (°)	Offset Wellbore Centre		Rule Assigned: Distance		Minimum Separation (usft)	Separation Factor	Warning			
Measured Depth (usft)	Vertical Depth (usft)	Measured Depth (usft)	Vertical Depth (usft)	Reference (usft)		Offset (usft)	+N/-S (usft)	+E/-W (usft)	Between Centres (usft)				Between Ellipses (usft)		
1,800.0	1,800.0	1,800.0	1,800.0	6.3	6.3	89.77	0.1	30.0	30.0	17.3	12.69	2.365			
1,900.0	1,900.0	1,900.0	1,900.0	6.7	6.7	89.77	0.1	30.0	30.0	16.6	13.41	2.238			
2,000.0	2,000.0	2,000.0	2,000.0	7.1	7.1	89.77	0.1	30.0	30.0	15.9	14.12	2.125 CC			
2,100.0	2,100.0	2,099.4	2,099.4	7.4	7.4	-82.33	1.7	30.8	30.6	15.7	14.82	2.063 ES, SF			
2,200.0	2,199.8	2,198.2	2,198.0	7.7	7.8	-98.29	6.2	33.1	34.1	18.6	15.48	2.202			
2,300.0	2,299.5	2,295.7	2,295.2	8.1	8.1	-116.50	13.7	37.0	44.2	28.1	16.11	2.745			
2,400.0	2,398.7	2,391.5	2,390.2	8.4	8.5	-130.11	23.9	42.2	62.7	45.9	16.72	3.747			
2,500.0	2,497.5	2,484.8	2,482.5	8.7	8.8	-138.64	36.5	48.7	88.8	71.5	17.31	5.130			
2,600.0	2,595.6	2,575.3	2,571.5	9.1	9.1	-143.87	51.4	56.3	121.9	104.0	17.89	6.814			
2,700.0	2,693.1	2,662.6	2,656.7	9.5	9.5	-147.14	68.0	64.8	161.1	142.7	18.43	8.742			
2,750.0	2,741.5	2,704.9	2,697.8	9.7	9.6	-148.30	76.9	69.4	183.0	164.3	18.70	9.783			
2,800.0	2,789.8	2,746.5	2,738.1	9.8	9.8	-149.45	86.2	74.1	205.8	186.9	18.96	10.856			
2,900.0	2,886.4	2,834.5	2,823.1	10.3	10.2	-151.17	106.5	84.5	252.5	232.9	19.60	12.880			
3,000.0	2,982.9	2,922.7	2,908.3	10.7	10.5	-152.37	126.8	94.9	299.2	279.0	20.25	14.773			
3,100.0	3,079.5	3,011.0	2,993.6	11.1	10.9	-153.24	147.1	105.3	346.1	325.1	20.91	16.547			
3,200.0	3,176.1	3,099.2	3,078.8	11.5	11.3	-153.91	167.4	115.7	392.9	371.4	21.58	18.210			
3,300.0	3,272.7	3,187.5	3,164.0	12.0	11.7	-154.43	187.8	126.2	439.8	417.6	22.25	19.770			
3,400.0	3,369.3	3,275.7	3,249.3	12.5	12.1	-154.85	208.1	136.6	486.8	463.9	22.92	21.235			
3,500.0	3,465.9	3,364.0	3,334.5	12.9	12.5	-155.20	228.4	147.0	533.7	510.1	23.60	22.613			
3,600.0	3,562.5	3,452.2	3,419.8	13.4	12.9	-155.49	248.8	157.4	580.7	556.4	24.29	23.910			
3,700.0	3,659.1	3,540.5	3,505.0	13.9	13.3	-155.74	269.1	167.8	627.7	602.7	24.98	25.132			
3,800.0	3,755.7	3,628.7	3,590.3	14.3	13.7	-155.96	289.4	178.2	674.7	649.0	25.67	26.284			
3,900.0	3,852.3	3,717.0	3,675.5	14.8	14.1	-156.14	309.7	188.6	721.6	695.3	26.36	27.373			
4,000.0	3,948.9	3,805.2	3,760.7	15.3	14.6	-156.31	330.1	199.1	768.6	741.6	27.06	28.403			
4,100.0	4,045.5	3,893.5	3,846.0	15.8	15.0	-156.45	350.4	209.5	815.6	787.9	27.76	29.378			
4,200.0	4,142.1	3,981.7	3,931.2	16.3	15.4	-156.58	370.7	219.9	862.6	834.2	28.47	30.302			
4,300.0	4,238.6	4,070.0	4,016.5	16.8	15.8	-156.69	391.0	230.3	909.6	880.5	29.18	31.178			
4,400.0	4,335.2	4,158.2	4,101.7	17.3	16.3	-156.80	411.4	240.7	956.6	926.8	29.89	32.010			

CC - Min centre to center distance or convergent point, SF - min separation factor, ES - min ellipse separation

Anticollision Report

Company:	NEW MEXICO	Local Co-ordinate Reference:	Well KOALA 9 FED COM 124H
Project:	(SP) EDDY	TVD Reference:	KB @ 3304.0usft
Reference Site:	KOALA FED	MD Reference:	KB @ 3304.0usft
Site Error:	0.0 usft	North Reference:	Grid
Reference Well:	KOALA 9 FED COM 124H	Survey Calculation Method:	Minimum Curvature
Well Error:	0.0 usft	Output errors are at	2.00 sigma
Reference Wellbore	OWB	Database:	Compass_17
Reference Design:	PWPO	Offset TVD Reference:	Offset Datum

Offset Design: KOALA FED - KOALA 9 FED COM 114H - OWB - PWPO													Offset Site Error:	0.0 usft
Survey Program: 0-MWD													Offset Well Error:	0.0 usft
Measured Reference Depth (usft)	Vertical Depth (usft)	Offset Measured Depth (usft)	Vertical Depth (usft)	Semi Major Axis Reference (usft)	Offset (usft)	Highside Toolface (°)	Offset Wellbore Centre		Distance Between Centres (usft)		Minimum Separation (usft)	Separation Factor	Warning	
							+N/-S (usft)	+E/-W (usft)	Between Centres (usft)	Between Ellipses (usft)				
0.0	0.0	0.0	0.0	0.0	0.0	89.77	0.2	60.0	60.0	59.5	0.50	119.576		
100.0	100.0	100.0	100.0	0.3	0.3	89.77	0.2	60.0	60.0	58.8	1.22	49.237		
200.0	200.0	200.0	200.0	0.6	0.6	89.77	0.2	60.0	60.0	58.1	1.94	31.001		
300.0	300.0	300.0	300.0	1.0	1.0	89.77	0.2	60.0	60.0	57.4	2.65	22.623		
400.0	400.0	400.0	400.0	1.3	1.3	89.77	0.2	60.0	60.0	57.2	2.82	21.284		
423.3	423.3	423.3	423.3	1.4	1.4	89.77	0.2	60.0	60.0	56.6	3.37	17.809		
500.0	500.0	500.0	500.0	1.7	1.7	89.77	0.2	60.0	60.0	56.5	3.55	16.916		
524.8	524.8	524.8	524.8	1.8	1.8	89.77	0.2	60.0	60.0	55.9	4.09	14.685		
600.0	600.0	600.0	600.0	2.0	2.0	89.77	0.2	60.0	60.0	55.7	4.33	13.873		
633.3	633.3	633.3	633.3	2.2	2.2	89.77	0.2	60.0	60.0	55.2	4.80	12.493		
700.0	700.0	700.0	700.0	2.4	2.4	89.77	0.2	60.0	60.0	54.5	5.52	10.871		
800.0	800.0	800.0	800.0	2.8	2.8	89.77	0.2	60.0	60.0	53.8	6.24	9.621		
900.0	900.0	900.0	900.0	3.1	3.1	89.77	0.2	60.0	60.0	53.1	6.95	8.629		
1,000.0	1,000.0	1,000.0	1,000.0	3.5	3.5	89.77	0.2	60.0	60.0	52.3	7.67	7.823		
1,100.0	1,100.0	1,100.0	1,100.0	3.8	3.8	89.77	0.2	60.0	60.0	51.6	8.39	7.154		
1,200.0	1,200.0	1,200.0	1,200.0	4.2	4.2	89.77	0.2	60.0	60.0	50.9	9.11	6.591		
1,300.0	1,300.0	1,300.0	1,300.0	4.6	4.6	89.77	0.2	60.0	60.0	50.2	9.82	6.110		
1,400.0	1,400.0	1,400.0	1,400.0	4.9	4.9	89.77	0.2	60.0	60.0	49.5	10.54	5.694		
1,500.0	1,500.0	1,500.0	1,500.0	5.3	5.3	89.77	0.2	60.0	60.0	49.2	11.24	5.380		
1,600.0	1,600.0	1,599.5	1,599.5	5.6	5.6	91.36	-1.4	60.4	60.4	50.1	11.91	5.204		
1,700.0	1,700.0	1,698.7	1,698.5	6.0	5.9	95.97	-6.4	61.7	62.0	52.9	12.59	5.198		
1,800.0	1,800.0	1,797.5	1,796.9	6.3	6.3	103.03	-14.7	63.7	65.5	58.5	13.26	5.411		
1,900.0	1,900.0	1,895.5	1,894.3	6.7	6.6	111.52	-26.2	66.5	71.7	67.8	13.90	5.876		
2,000.0	2,000.0	1,992.6	1,990.2	7.1	6.9	120.19	-40.8	70.1	81.7	79.9	14.51	6.508		
2,100.0	2,100.0	2,089.0	2,084.8	7.4	7.3	-38.46	-58.3	74.4	94.4	93.1	15.08	7.177		
2,200.0	2,199.8	2,184.8	2,178.3	7.7	7.6	-32.88	-78.8	79.5	108.2	106.9	15.67	7.820		
2,300.0	2,299.5	2,281.2	2,271.6	8.1	8.0	-28.61	-102.4	85.3	122.5	118.6	16.33	8.260		
2,400.0	2,398.7	2,380.2	2,367.2	8.4	8.5	-25.66	-127.3	91.4	134.9	127.4	17.02	8.486		
2,500.0	2,497.5	2,479.6	2,463.3	8.7	8.9	-23.77	-152.3	97.5	144.4	133.1	17.71	8.513		
2,600.0	2,595.6	2,579.4	2,559.6	9.1	9.3	-22.64	-177.3	103.7	150.8	135.6	18.43	8.357		
2,700.0	2,693.1	2,679.3	2,656.1	9.5	9.8	-22.10	-202.4	109.9	154.0	135.6	18.43	8.357		
2,750.0	2,741.5	2,729.3	2,704.4	9.7	10.0	-22.02	-215.0	113.0	154.4	135.6	18.79	8.217		
2,800.0	2,789.8	2,779.3	2,752.7	9.8	10.3	-22.02	-227.6	116.1	154.4	135.2	19.16	8.059		
2,900.0	2,886.4	2,879.3	2,849.3	10.3	10.7	-22.00	-252.7	122.2	154.4	134.5	19.90	7.759		
3,000.0	2,982.9	2,979.3	2,945.9	10.7	11.2	-21.98	-277.8	128.4	154.4	133.7	20.65	7.477		
3,100.0	3,079.5	3,079.3	3,042.5	11.1	11.7	-21.97	-303.0	134.6	154.3	132.9	21.40	7.212		
3,200.0	3,176.1	3,179.3	3,139.1	11.5	12.2	-21.95	-328.1	140.8	154.3	132.2	22.17	6.962		
3,300.0	3,272.7	3,279.3	3,235.7	12.0	12.7	-21.94	-353.2	147.0	154.3	131.4	22.94	6.728		
3,400.0	3,369.3	3,379.3	3,332.3	12.5	13.2	-21.92	-378.4	153.2	154.3	130.6	23.71	6.507		
3,500.0	3,465.9	3,479.3	3,428.9	12.9	13.7	-21.90	-403.5	159.4	154.3	129.8	24.49	6.299		
3,600.0	3,562.5	3,579.3	3,525.5	13.4	14.2	-21.89	-428.6	165.5	154.3	129.0	25.28	6.102		
3,700.0	3,659.1	3,679.3	3,622.1	13.9	14.7	-21.87	-453.8	171.7	154.2	128.2	26.07	5.917		
3,800.0	3,755.7	3,779.3	3,718.7	14.3	15.2	-21.86	-478.9	177.9	154.2	127.4	26.86	5.741		
3,900.0	3,852.3	3,879.3	3,815.3	14.8	15.8	-21.84	-504.0	184.1	154.2	126.5	27.66	5.575		
4,000.0	3,948.9	3,979.3	3,911.8	15.3	16.3	-21.82	-529.2	190.3	154.2	125.7	28.46	5.417		
4,100.0	4,045.5	4,079.3	4,008.4	15.8	16.8	-21.81	-554.3	196.5	154.2	124.9	29.26	5.268		
4,200.0	4,142.1	4,179.3	4,105.0	16.3	17.3	-21.79	-579.4	202.6	154.2	124.1	30.07	5.126		
4,300.0	4,238.6	4,279.3	4,201.6	16.8	17.9	-21.77	-604.6	208.8	154.1	123.3	30.88	4.991		
4,400.0	4,335.2	4,379.3	4,298.2	17.3	18.4	-21.76	-629.7	215.0	154.1	122.4	31.69	4.863		
4,500.0	4,431.8	4,479.3	4,394.8	17.8	18.9	-21.74	-654.8	221.2	154.1	121.6	32.50	4.741		
4,600.0	4,528.4	4,579.3	4,491.4	18.4	19.4	-21.73	-680.0	227.4	154.1	120.8	33.32	4.624		
4,700.0	4,625.0	4,679.3	4,588.0	18.9	20.0	-21.71	-705.1	233.6	154.1	119.9	34.14	4.513		

CC - Min centre to center distance or convergent point, SF - min separation factor, ES - min ellipse separation

Anticollision Report

Company:	NEW MEXICO	Local Co-ordinate Reference:	Well KOALA 9 FED COM 124H
Project:	(SP) EDDY	TVD Reference:	KB @ 3304.0usft
Reference Site:	KOALA FED	MD Reference:	KB @ 3304.0usft
Site Error:	0.0 usft	North Reference:	Grid
Reference Well:	KOALA 9 FED COM 124H	Survey Calculation Method:	Minimum Curvature
Well Error:	0.0 usft	Output errors are at	2.00 sigma
Reference Wellbore	OWB	Database:	Compass_17
Reference Design:	PWPO	Offset TVD Reference:	Offset Datum

Offset Design: KOALA FED - KOALA 9 FED COM 114H - OWB - PWPO													Offset Site Error:	0.0 usft
Survey Program: 0-MWD													Offset Well Error:	0.0 usft
Measured Reference Depth (usft)	Vertical Reference Depth (usft)	Offset Measured Depth (usft)	Vertical Offset Depth (usft)	Semi Major Axis Reference (usft)	Offset (usft)	Highside Toolface (°)	Offset Wellbore Centre		Rule Assigned: Distance Between Centres (usft)		Minimum Separation (usft)	Separation Factor	Warning	
Depth (usft)	Depth (usft)	Depth (usft)	Depth (usft)	(usft)	(usft)	(°)	+N/-S (usft)	+E/-W (usft)	Between Centres (usft)	Between Ellipses (usft)	(usft)			
4,800.0	4,721.6	4,781.9	4,687.2	19.4	20.5	-21.76	-730.4	239.8	153.6	118.6	35.01	4.388		
4,900.0	4,818.2	4,887.0	4,789.7	19.9	21.0	-22.29	-753.2	245.4	150.2	114.3	35.94	4.180		
5,000.0	4,914.8	4,991.7	4,892.5	20.4	21.5	-23.44	-772.3	250.1	143.5	106.6	36.88	3.891		
5,100.0	5,011.4	5,095.7	4,995.3	20.9	22.0	-25.38	-787.6	253.9	133.5	95.7	37.84	3.528		
5,200.0	5,108.0	5,198.7	5,097.6	21.5	22.4	-28.45	-799.2	256.7	120.5	81.6	38.88	3.100		
5,230.3	5,137.3	5,229.7	5,128.5	21.6	22.5	-29.69	-802.0	257.4	116.0	76.8	39.22	2.959		
5,300.0	5,204.8	5,300.7	5,199.2	22.0	22.8	-32.93	-807.1	258.7	105.6	65.6	40.06	2.637		
5,400.0	5,302.4	5,402.0	5,300.4	22.5	23.1	-38.84	-811.6	259.8	91.4	50.0	41.42	2.207		
5,500.0	5,400.7	5,502.2	5,400.7	22.9	23.4	-46.71	-812.6	260.0	78.5	35.5	43.05	1.824		
5,600.0	5,499.5	5,601.1	5,499.5	23.4	23.6	-55.56	-812.6	260.0	69.1	24.2	44.82	1.541		
5,700.0	5,598.9	5,700.4	5,598.9	23.8	23.9	-64.03	-812.6	260.0	63.2	16.8	46.39	1.363	Level 3	
5,800.0	5,698.5	5,800.1	5,698.5	24.1	24.2	-70.85	-812.6	260.0	60.1	12.5	47.61	1.263	Level 3	
5,900.0	5,798.4	5,900.0	5,798.4	24.5	24.5	-75.01	-812.6	260.0	58.8	10.3	48.50	1.212	Level 3	
5,930.4	5,828.8	5,930.1	5,828.5	24.5	24.6	-75.66	-812.6	260.0	58.6	9.9	48.71	1.203	Level 3, CC, ES, SF	
5,980.3	5,878.8	5,975.0	5,873.3	24.7	24.7	89.99	-812.6	262.3	61.1	12.1	48.95	1.247	Level 3	
6,000.0	5,898.4	5,991.8	5,890.0	24.8	24.7	89.97	-812.6	264.2	63.3	14.4	48.90	1.295	Level 3	
6,100.0	5,998.4	6,075.0	5,971.1	25.0	25.0	89.90	-812.4	282.4	85.4	37.6	47.82	1.786		
6,200.0	6,098.4	6,150.0	6,040.5	25.3	25.3	89.82	-812.2	310.7	123.6	77.8	45.79	2.698		
6,300.0	6,198.4	6,217.7	6,098.7	25.6	25.5	89.78	-812.0	345.2	174.9	131.1	43.79	3.994		
6,400.0	6,298.4	6,275.0	6,143.7	25.9	25.7	89.75	-811.8	380.6	236.7	195.0	41.62	5.686		
6,500.0	6,398.4	6,318.6	6,174.9	26.2	25.9	89.73	-811.6	411.0	306.3	267.2	39.11	7.834		
6,600.0	6,498.4	6,356.6	6,199.8	26.5	26.1	89.71	-811.4	439.7	382.0	344.9	37.10	10.297		
6,700.0	6,598.4	6,388.3	6,218.7	26.8	26.2	89.71	-811.2	465.2	462.3	426.9	35.38	13.064		
6,800.0	6,698.4	6,414.9	6,233.3	27.1	26.3	89.70	-811.1	487.4	546.0	512.1	33.94	16.088		
6,900.0	6,798.4	6,437.4	6,244.6	27.4	26.5	89.69	-810.9	506.9	632.4	599.7	32.73	19.320		
6,953.1	6,851.5	6,450.0	6,250.5	27.5	26.5	89.69	-810.9	518.0	679.2	646.9	32.28	21.041		
6,975.0	6,873.4	6,450.0	6,250.5	27.6	26.5	0.06	-810.9	518.0	698.4	666.6	31.85	21.932		
7,000.0	6,898.3	6,450.0	6,250.5	27.7	26.5	0.06	-810.9	518.0	720.0	688.6	31.34	22.976		
7,025.0	6,923.1	6,462.9	6,256.3	27.7	26.6	0.05	-810.8	529.5	740.8	709.4	31.40	23.592		
7,050.0	6,947.7	6,475.0	6,261.4	27.8	26.6	0.05	-810.7	540.5	761.2	729.8	31.39	24.252		
7,075.0	6,972.1	6,475.0	6,261.4	27.9	26.6	0.04	-810.7	540.5	780.8	750.0	30.82	25.337		
7,100.0	6,996.1	6,475.0	6,261.4	28.0	26.6	0.04	-810.7	540.5	800.0	769.7	30.25	26.447		
7,125.0	7,019.7	6,486.8	6,266.2	28.1	26.7	0.04	-810.7	551.3	818.4	788.2	30.15	27.140		
7,150.0	7,042.9	6,500.0	6,271.1	28.2	26.8	0.04	-810.6	563.5	836.2	806.1	30.09	27.790		
7,175.0	7,065.5	6,500.0	6,271.1	28.3	26.8	0.03	-810.6	563.5	853.2	823.7	29.49	28.929		
7,200.0	7,087.5	6,500.0	6,271.1	28.4	26.8	0.03	-810.6	563.5	869.6	840.7	28.90	30.089		
7,225.0	7,108.9	6,513.4	6,275.9	28.4	26.9	0.03	-810.5	576.1	885.2	856.4	28.80	30.732		
7,250.0	7,129.6	6,525.0	6,279.6	28.5	26.9	0.03	-810.4	587.0	900.1	871.5	28.62	31.448		
7,275.0	7,149.6	6,525.0	6,279.6	28.6	26.9	0.03	-810.4	587.0	914.2	886.2	28.03	32.614		
7,300.0	7,168.7	6,534.8	6,282.6	28.7	27.0	0.03	-810.4	596.3	927.5	899.8	27.78	33.392		
7,325.0	7,186.9	6,550.0	6,286.9	28.8	27.1	0.03	-810.3	610.9	940.2	912.5	27.70	33.946		
7,350.0	7,204.2	6,550.0	6,286.9	28.9	27.1	0.03	-810.3	610.9	951.8	924.7	27.12	35.092		
7,375.0	7,220.6	6,550.0	6,286.9	29.0	27.1	0.02	-810.3	610.9	962.8	936.2	26.57	36.233		
7,400.0	7,236.0	6,564.5	6,290.5	29.1	27.2	0.02	-810.2	625.0	972.8	946.3	26.46	36.761		
7,425.0	7,250.2	6,575.0	6,292.9	29.2	27.3	0.02	-810.1	635.2	982.1	955.8	26.24	37.433		
7,450.0	7,263.4	6,575.0	6,292.9	29.3	27.3	0.02	-810.1	635.2	990.5	964.7	25.73	38.496		
7,475.0	7,275.5	6,587.6	6,295.4	29.5	27.4	0.02	-810.0	647.5	998.0	972.4	25.58	39.021		

CC - Min centre to center distance or convergent point, SF - min separation factor, ES - min ellipse separation

Anticollision Report

Company:	NEW MEXICO	Local Co-ordinate Reference:	Well KOALA 9 FED COM 124H
Project:	(SP) EDDY	TVD Reference:	KB @ 3304.0usft
Reference Site:	KOALA FED	MD Reference:	KB @ 3304.0usft
Site Error:	0.0 usft	North Reference:	Grid
Reference Well:	KOALA 9 FED COM 124H	Survey Calculation Method:	Minimum Curvature
Well Error:	0.0 usft	Output errors are at	2.00 sigma
Reference Wellbore	OWB	Database:	Compass_17
Reference Design:	PWPO	Offset TVD Reference:	Offset Datum

Reference Depths are relative to KB @ 3304.0usft
 Offset Depths are relative to Offset Datum
 Central Meridian is 104° 20' 0.000 W

Coordinates are relative to: KOALA 9 FED COM 124H
 Coordinate System is US State Plane 1983, New Mexico Eastern Zone
 Grid Convergence at Surface is: 0.08°

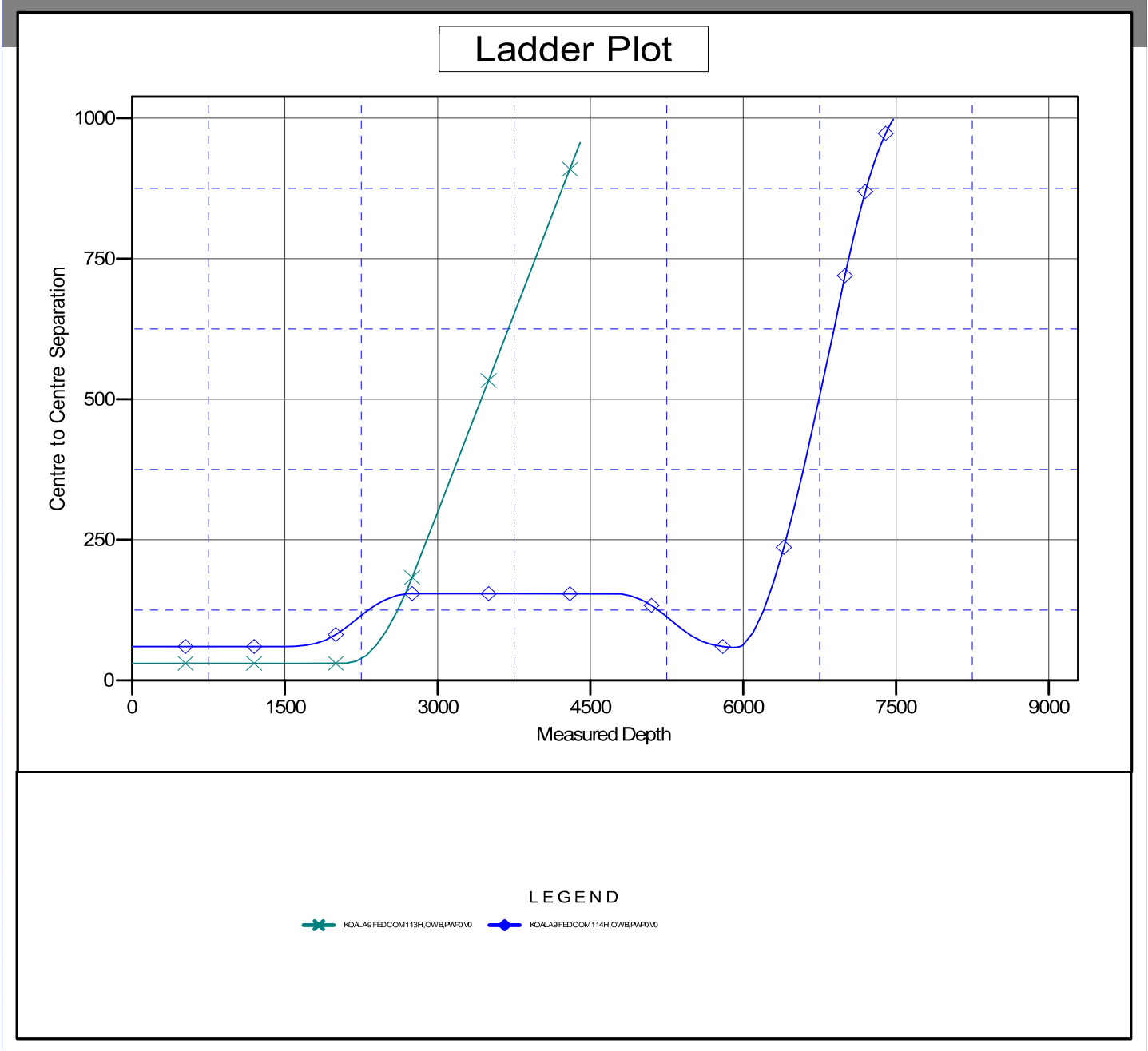

Anticollision Report

Company:	NEW MEXICO	Local Co-ordinate Reference:	Well KOALA 9 FED COM 124H
Project:	(SP) EDDY	TVD Reference:	KB @ 3304.0usft
Reference Site:	KOALA FED	MD Reference:	KB @ 3304.0usft
Site Error:	0.0 usft	North Reference:	Grid
Reference Well:	KOALA 9 FED COM 124H	Survey Calculation Method:	Minimum Curvature
Well Error:	0.0 usft	Output errors are at	2.00 sigma
Reference Wellbore	OWB	Database:	Compass_17
Reference Design:	PWPO	Offset TVD Reference:	Offset Datum

Reference Depths are relative to KB @ 3304.0usft
 Offset Depths are relative to Offset Datum
 Central Meridian is 104° 20' 0.000 W

Coordinates are relative to: KOALA 9 FED COM 124H
 Coordinate System is US State Plane 1983, New Mexico Eastern Zone
 Grid Convergence at Surface is: 0.08°

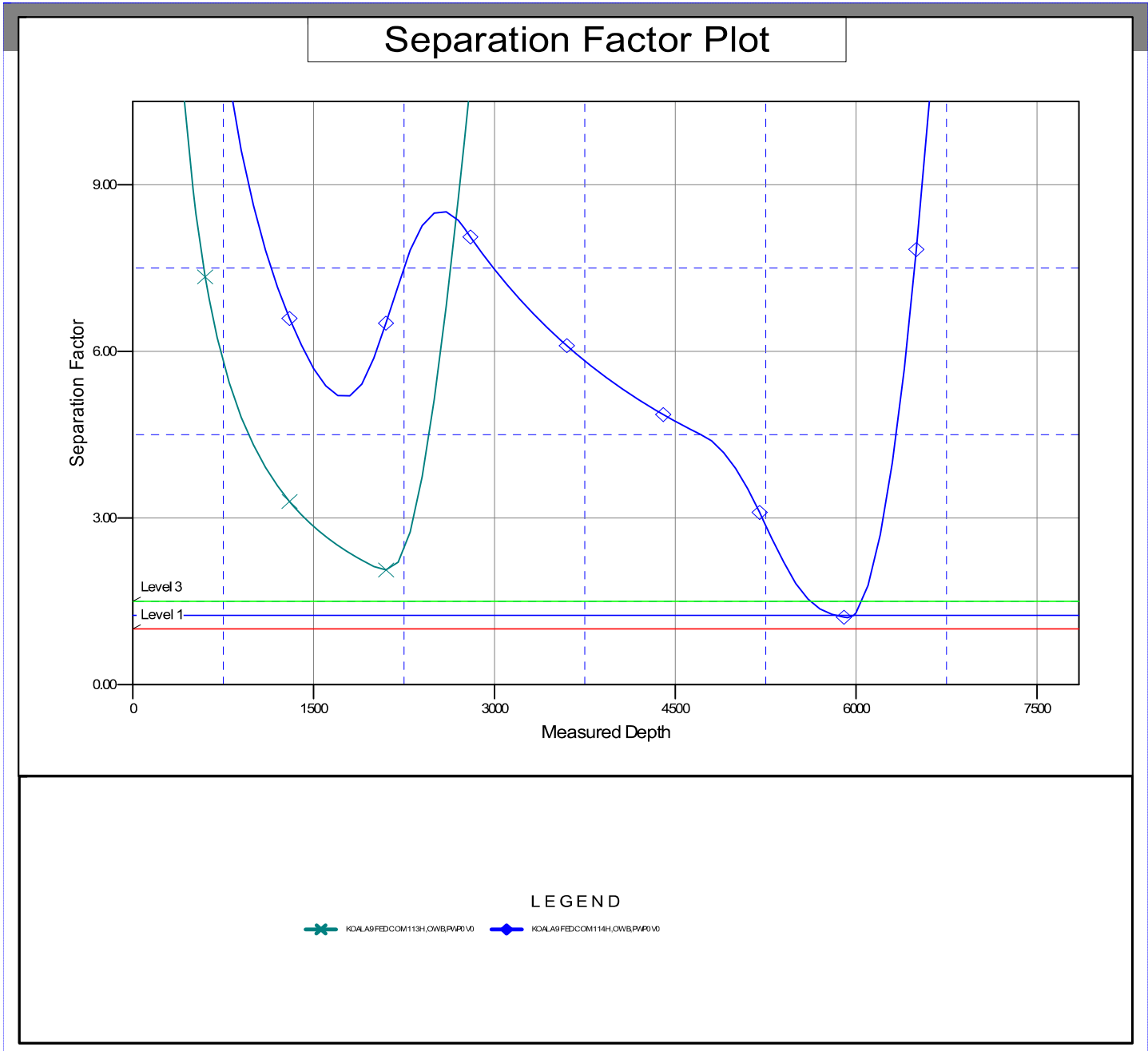

State of New Mexico
 Energy, Minerals and Natural Resources Department

Submit Electronically
 Via E-permitting

Oil Conservation Division
 1220 South St. Francis Dr.
 Santa Fe, NM 87505

NATURAL GAS MANAGEMENT PLAN

This Natural Gas Management Plan must be submitted with each Application for Permit to Drill (APD) for a new or recompleted well.

Section 1 – Plan Description
Effective May 25, 2021

I. Operator: Permian Resource Operating, LLC **OGRID:** 372165 **Date:** 10/16/25

II. Type: Original Amendment due to 19.15.27.9.D(6)(a) NMAC 19.15.27.9.D(6)(b) NMAC Other.

If Other, please describe: _____

III. Well(s): Provide the following information for each new or recompleted well or set of wells proposed to be drilled or proposed to be recompleted from a single well pad or connected to a central delivery point.

Well Name	API	ULSTR	Footages	Anticipated Oil BBL/D	Anticipated Gas MCF/D	Anticipated Produced Water BBL/D
Koala 9 Fed Com 111H		A – 8 – 20S – 28E	796 FNL 362 FEL	700	3900	4800
Koala 9 Fed Com 112H		A – 8 – 20S – 28E	797 FNL 332 FEL	700	3900	4800
Koala 9 Fed Com 113H		P – 8 – 20S – 28E	1144 FSL 135 FEL	700	3900	4800
Koala 9 Fed Com 114H		P – 8 – 20S – 28E	1144 FSL 105 FEL	700	3900	4800
Koala 9 Fed Com 121H		A – 8 – 20S – 28E	795 FNL 422 FEL	1700	3400	4400
Koala 9 Fed Com 123H		P – 8 – 20S – 28E	1144 FSL 195 FEL	1700	3400	4400
Koala 9 Fed Com 124H		P – 8 – 20S – 28E	1144 FSL 165 FEL	1700	3400	4400
Koala 9 Fed Com 131H		A – 8 – 20S – 28E	794 FNL 482 FEL	1300	3100	3300

Page 6

IV. Central Delivery Point Name: Dundee/Koala Battery

[See 19.15.27.9(D)(1) NMAC]

V. Anticipated Schedule: Provide the following information for each new or recompleted well or set of wells proposed to be drilled or proposed to be recompleted from a single well pad or connected to a central delivery point.

Well Name	API	Spud Date	TD Reached Date	Completion Commencement Date	Initial Flow Back Date	First Production Date
Koala 9 Fed Com 111H		4/1/2026	5/20/2026	10/1/2026	Not Yet Scheduled	Not Yet Scheduled
Koala 9 Fed Com 112H		4/1/2026	5/20/2026	10/1/2026	Not Yet Scheduled	Not Yet Scheduled
Koala 9 Fed Com 113H		4/1/2026	5/20/2026	10/1/2026	Not Yet Scheduled	Not Yet Scheduled
Koala 9 Fed Com 114H		4/1/2026	5/20/2026	10/1/2026	Not Yet Scheduled	Not Yet Scheduled
Koala 9 Fed Com 121H		4/1/2026	5/20/2026	10/1/2026	Not Yet Scheduled	Not Yet Scheduled
Koala 9 Fed Com 122H		4/1/2026	5/20/2026	10/1/2026	Not Yet Scheduled	Not Yet Scheduled
Koala 9 Fed Com 123H		4/1/2026	5/20/2026	10/1/2026	Not Yet Scheduled	Not Yet Scheduled
Koala 9 Fed Com 124H		4/1/2026	5/20/2026	10/1/2026	Not Yet Scheduled	Not Yet Scheduled
Koala 9 Fed Com 131H		4/1/2026	5/20/2026	10/1/2026	Not Yet Scheduled	Not Yet Scheduled
Koala 9 Fed Com 132H		4/1/2026	5/20/2026	10/1/2026	Not Yet Scheduled	Not Yet Scheduled
Koala 9 Fed Com 133H		4/1/2026	5/20/2026	10/1/2026	Not Yet Scheduled	Not Yet Scheduled
Koala 9 Fed Com 134H		4/1/2026	5/20/2026	10/1/2026	Not Yet Scheduled	Not Yet Scheduled
Koala 9 Fed Com 201H		4/1/2026	5/20/2026	10/1/2026	Not Yet Scheduled	Not Yet Scheduled
Koala 9 Fed Com 202H		4/1/2026	5/20/2026	10/1/2026	Not Yet Scheduled	Not Yet Scheduled
Koala 9 Fed Com 203H		4/1/2026	5/20/2026	10/1/2026	Not Yet Scheduled	Not Yet Scheduled
Koala 9 Fed Com 204H		4/1/2026	5/20/2026	10/1/2026	Not Yet Scheduled	Not Yet Scheduled

VI. Separation Equipment: Attach a complete description of how Operator will size separation equipment to optimize gas capture.**VII. Operational Practices:** Attach a complete description of the actions Operator will take to comply with the requirements of Subsection A through F of 19.15.27.8 NMAC.**VIII. Best Management Practices:** Attach a complete description of Operator's best management practices to minimize venting during active and planned maintenance.

Section 2 – Enhanced Plan
EFFECTIVE APRIL 1, 2022

Beginning April 1, 2022, an operator that is not in compliance with its statewide natural gas capture requirement for the applicable reporting area must complete this section.

Operator certifies that it is not required to complete this section because Operator is in compliance with its statewide natural gas capture requirement for the applicable reporting area.

IX. Anticipated Natural Gas Production:

Well	API	Anticipated Average Natural Gas Rate MCF/D	Anticipated Volume of Natural Gas for the First Year MCF

X. Natural Gas Gathering System (NGGS):

Operator	System	ULSTR of Tie-in	Anticipated Gathering Start Date	Available Maximum Daily Capacity of System Segment Tie-in

XI. Map. Attach an accurate and legible map depicting the location of the well(s), the anticipated pipeline route(s) connecting the production operations to the existing or planned interconnect of the natural gas gathering system(s), and the maximum daily capacity of the segment or portion of the natural gas gathering system(s) to which the well(s) will be connected.

XII. Line Capacity. The natural gas gathering system will will not have capacity to gather 100% of the anticipated natural gas production volume from the well prior to the date of first production.

XIII. Line Pressure. Operator does does not anticipate that its existing well(s) connected to the same segment, or portion, of the natural gas gathering system(s) described above will continue to meet anticipated increases in line pressure caused by the new well(s).

Attach Operator’s plan to manage production in response to the increased line pressure.

XIV. Confidentiality: Operator asserts confidentiality pursuant to Section 71-2-8 NMSA 1978 for the information provided in Section 2 as provided in Paragraph (2) of Subsection D of 19.15.27.9 NMAC, and attaches a full description of the specific information for which confidentiality is asserted and the basis for such assertion.

Section 3 - Certifications

Effective May 25, 2021

Operator certifies that, after reasonable inquiry and based on the available information at the time of submittal:

Operator will be able to connect the well(s) to a natural gas gathering system in the general area with sufficient capacity to transport one hundred percent of the anticipated volume of natural gas produced from the well(s) commencing on the date of first production, taking into account the current and anticipated volumes of produced natural gas from other wells connected to the pipeline gathering system; or

Operator will not be able to connect to a natural gas gathering system in the general area with sufficient capacity to transport one hundred percent of the anticipated volume of natural gas produced from the well(s) commencing on the date of first production, taking into account the current and anticipated volumes of produced natural gas from other wells connected to the pipeline gathering system.

If Operator checks this box, Operator will select one of the following:

Well Shut-In. Operator will shut-in and not produce the well until it submits the certification required by Paragraph (4) of Subsection D of 19.15.27.9 NMAC; or

Venting and Flaring Plan. Operator has attached a venting and flaring plan that evaluates and selects one or more of the potential alternative beneficial uses for the natural gas until a natural gas gathering system is available, including:

- (a) power generation on lease;
- (b) power generation for grid;
- (c) compression on lease;
- (d) liquids removal on lease;
- (e) reinjection for underground storage;
- (f) reinjection for temporary storage;
- (g) reinjection for enhanced oil recovery;
- (h) fuel cell production; and
- (i) other alternative beneficial uses approved by the division.

Section 4 - Notices

1. If, at any time after Operator submits this Natural Gas Management Plan and before the well is spud:

(a) Operator becomes aware that the natural gas gathering system it planned to connect the well(s) to has become unavailable or will not have capacity to transport one hundred percent of the production from the well(s), no later than 20 days after becoming aware of such information, Operator shall submit for OCD's approval a new or revised venting and flaring plan containing the information specified in Paragraph (5) of Subsection D of 19.15.27.9 NMAC; or

(b) Operator becomes aware that it has, cumulatively for the year, become out of compliance with its baseline natural gas capture rate or natural gas capture requirement, no later than 20 days after becoming aware of such information, Operator shall submit for OCD's approval a new or revised Natural Gas Management Plan for each well it plans to spud during the next 90 days containing the information specified in Paragraph (2) of Subsection D of 19.15.27.9 NMAC, and shall file an update for each Natural Gas Management Plan until Operator is back in compliance with its baseline natural gas capture rate or natural gas capture requirement.

2. OCD may deny or conditionally approve an APD if Operator does not make a certification, fails to submit an adequate venting and flaring plan which includes alternative beneficial uses for the anticipated volume of natural gas produced, or if OCD determines that Operator will not have adequate natural gas takeaway capacity at the time a well will be spud.

Page

I certify that, after reasonable inquiry, the statements in and attached to this Natural Gas Management Plan are true and correct to the best of my knowledge and acknowledge that a false statement may be subject to civil and criminal penalties under the Oil and Gas Act.

Signature: <i>Cassie Evans</i>
Printed Name: Cassie Evans
Title: Regulatory
E-mail Address: cassie.evans@permianres.com
Date: 10/16/25
Phone: 432-313-1732

OIL CONSERVATION DIVISION
(Only applicable when submitted as a standalone form)

Approved By:
Title:
Approval Date:
Conditions of Approval:

Permian Resources Operating, LLC (372165)

Natural Gas Management Plan Descriptions**VI. Separation Equipment:**

Permian utilizes a production forecast from our Reservoir Engineering team to appropriately size each permanent, 3-phase separator and heater treater utilized for production operations. Our goal is to maintain 5 minutes of retention time in the test vessel and 20 minutes in the heater treater at peak production rates. The gas produced is routed from the separator to the gas sales line.

VII. Operational Practices:*Drilling*

During Permian's drilling operations it is uncommon for venting or flaring to occur. If flaring is needed due to safety concerns, gas will be routed to a flare and volumes will be estimated.

Flowback

During completion/recompletion flowback operations, after separation flowback begins and as soon as it is technically feasible, Permian routes gas through a permanent separator and the controlled facility where the gas is either sold or flared through a high-pressure flare if needed.

Production

Per 19.15.27.8.D, Permian's facilities are designed to minimize waste. Our produced gas will only be vented or flared in an emergency or malfunction situation, except as allowed for normal operations noted in 19.15.27.8.D(2) & (4). All gas that is flared is metered. All gas that may be vented will be estimated.

Performance Standards

Permian utilizes a production forecast from our Reservoir Engineering team to appropriately size each permanent, 3-phase separator and heater treater utilized for production operations.

All of Permian's permanent storage tanks associated with production operations which are routed to a flare or control device are equipped with an automatic gauging system.

All of Permian's flare stacks, both currently installed and for future installation, are:

- 1) Appropriately sized and designed to ensure proper combustion efficiency.
- 2) Equipped with an automatic ignitor or continuous pilot.
- 3) Anchored and located at least 100 feet from the well and storage tanks.

Permian's field operations and HSE teams have implemented an AVO inspection schedule that adheres to the requirements of 19.15.27.8.E(5).

All of our operations and facilities are designed to minimize waste. We routinely employ the following methods and practices:

- Closed-loop systems
- Enclosed and properly sized tanks

Permian Resources Operating, LLC (372165)

- Vapor recovery units to maximize recovery of low-pressure gas streams and potential unauthorized emissions
- Low-emitting or electric engines whenever practical
- Combustors and flare stacks in the event of a malfunction or emergency
- Routine facility inspections to identify leaking components, functioning control devices, such as flares and combustors, and repair / replacement of malfunctioning components where applicable

Measurement or estimation

Permian measures or estimates the volumes of natural gas vented, flared and/or beneficially used for all of our drilling, completing and producing wells. We utilize accepted industry standards and methodology which can be independently verified. Annual GOR testing is completed on our wells and will be submitted as required by the OCD. None of our equipment is designed to allow diversion around metering elements except during inspection, maintenance and repair operations.

VIII. Best Management Practices:

Permian utilizes the following BMPs to minimize venting during active and planned maintenance activities:

- Use a closed-loop process wherever possible during planned maintenance activities, such as blowdowns, liquid removal, and work over operations.
- Employ low-emitting or electric engines for equipment, such as compressors
- Adhere to a strict preventative maintenance program which includes routine facility inspections, identification of component malfunctions, and repairing or replacing components such as hatches, seals, valves, etc. where applicable
- Utilize vapor recovery units (VRU's) to maximize recovery of volumes of low-pressure gas streams and potential unauthorized emissions
- Route low pressure gas and emissions streams to a combustion device to prevent venting where necessary

Permian Resources Operating, LLC (372165)

Natural Gas Management Plan Descriptions**VI. Separation Equipment:**

Permian utilizes a production forecast from our Reservoir Engineering team to appropriately size each permanent, 3-phase separator and heater treater utilized for production operations. Our goal is to maintain 5 minutes of retention time in the test vessel and 20 minutes in the heater treater at peak production rates. The gas produced is routed from the separator to the gas sales line.

VII. Operational Practices:*Drilling*

During Permian's drilling operations it is uncommon for venting or flaring to occur. If flaring is needed due to safety concerns, gas will be routed to a flare and volumes will be estimated.

Flowback

During completion/recompletion flowback operations, after separation flowback begins and as soon as it is technically feasible, Permian routes gas through a permanent separator and the controlled facility where the gas is either sold or flared through a high-pressure flare if needed.

Production

Per 19.15.27.8.D, Permian's facilities are designed to minimize waste. Our produced gas will only be vented or flared in an emergency or malfunction situation, except as allowed for normal operations noted in 19.15.27.8.D(2) & (4). All gas that is flared is metered. All gas that may be vented will be estimated.

Performance Standards

Permian utilizes a production forecast from our Reservoir Engineering team to appropriately size each permanent, 3-phase separator and heater treater utilized for production operations.

All of Permian's permanent storage tanks associated with production operations which are routed to a flare or control device are equipped with an automatic gauging system.

All of Permian's flare stacks, both currently installed and for future installation, are:

- 1) Appropriately sized and designed to ensure proper combustion efficiency.
- 2) Equipped with an automatic ignitor or continuous pilot.
- 3) Anchored and located at least 100 feet from the well and storage tanks.

Permian's field operations and HSE teams have implemented an AVO inspection schedule that adheres to the requirements of 19.15.27.8.E(5).

All of our operations and facilities are designed to minimize waste. We routinely employ the following methods and practices:

- Closed-loop systems
- Enclosed and properly sized tanks

Permian Resources Operating, LLC (372165)

- Vapor recovery units to maximize recovery of low-pressure gas streams and potential unauthorized emissions
- Low-emitting or electric engines whenever practical
- Combustors and flare stacks in the event of a malfunction or emergency
- Routine facility inspections to identify leaking components, functioning control devices, such as flares and combustors, and repair / replacement of malfunctioning components where applicable

Measurement or estimation

Permian measures or estimates the volumes of natural gas vented, flared and/or beneficially used for all of our drilling, completing and producing wells. We utilize accepted industry standards and methodology which can be independently verified. Annual GOR testing is completed on our wells and will be submitted as required by the OCD. None of our equipment is designed to allow diversion around metering elements except during inspection, maintenance and repair operations.

VIII. Best Management Practices:

Permian utilizes the following BMPs to minimize venting during active and planned maintenance activities:

- Use a closed-loop process wherever possible during planned maintenance activities, such as blowdowns, liquid removal, and work over operations.
- Employ low-emitting or electric engines for equipment, such as compressors
- Adhere to a strict preventative maintenance program which includes routine facility inspections, identification of component malfunctions, and repairing or replacing components such as hatches, seals, valves, etc. where applicable
- Utilize vapor recovery units (VRU's) to maximize recovery of volumes of low-pressure gas streams and potential unauthorized emissions
- Route low pressure gas and emissions streams to a combustion device to prevent venting where necessary

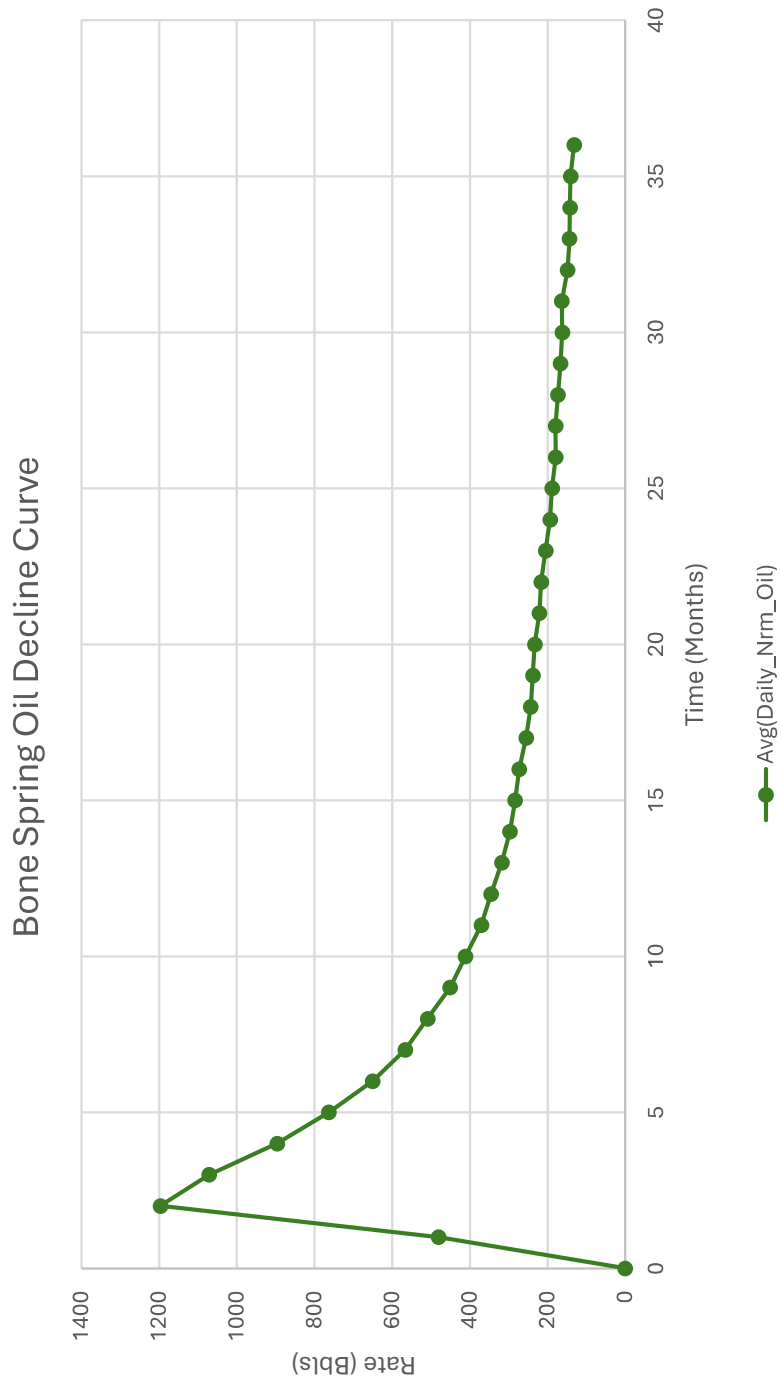

1. Represented curve is generic based on 3-Years available information for the Bone Spring formation and may not be representative of forecasted production or actual volumes.
2. Decline curves are based on an average 10,000ft lateral length. Multiple factors may influence production and decline curves, including but not limited to: lateral length and completion type.

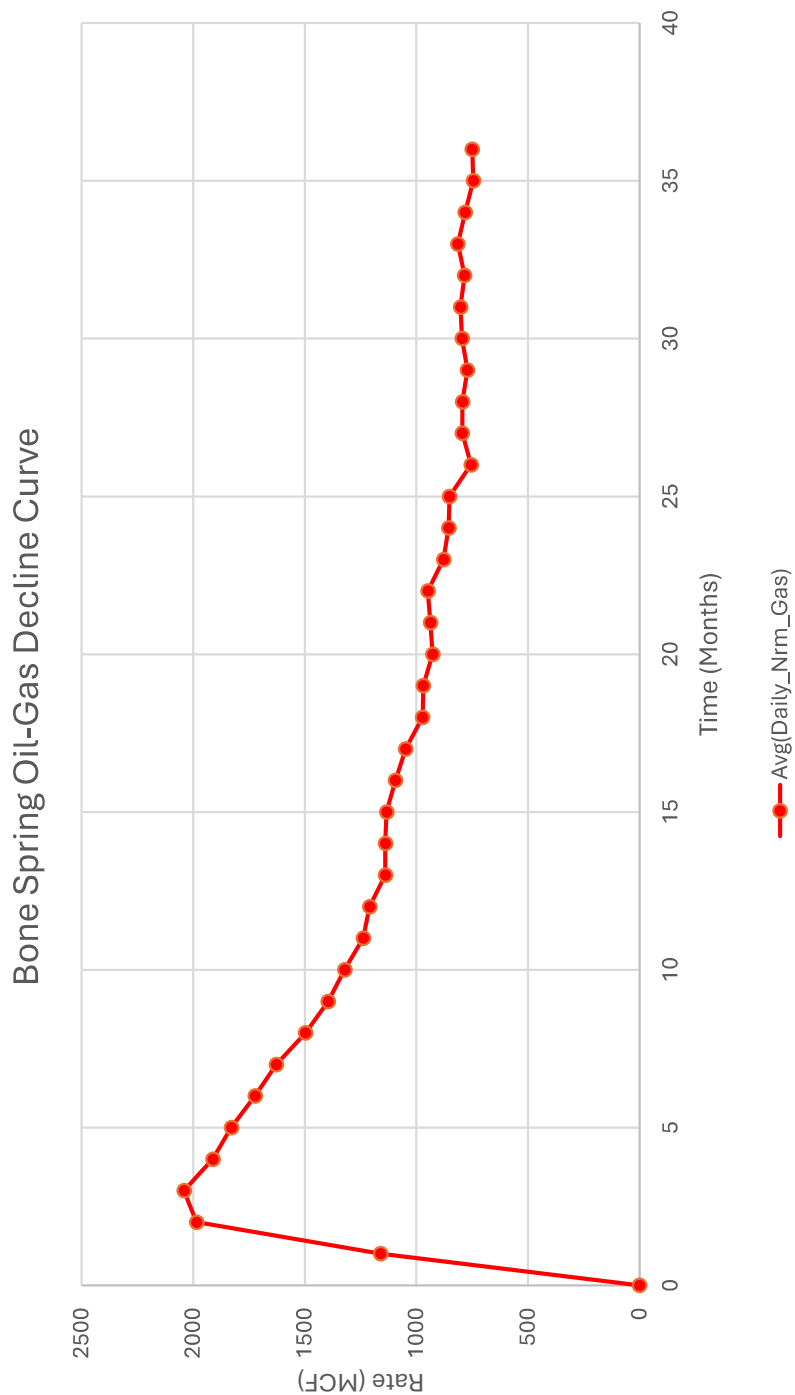

1. Represented curve is generic based on 3-Years available information for the Bone Spring formation and may not be representative of forecasted production or actual volumes.
2. Decline curves are based on an average 10,000ft lateral length. Multiple factors may influence production and decline curves, including but not limited to: lateral length and completion type.

Permian Resources Operating, LLC (372165)

Natural Gas Management Plan Descriptions**VI. Separation Equipment:**

Permian utilizes a production forecast from our Reservoir Engineering team to appropriately size each permanent, 3-phase separator and heater treater utilized for production operations. Our goal is to maintain 5 minutes of retention time in the test vessel and 20 minutes in the heater treater at peak production rates. The gas produced is routed from the separator to the gas sales line.

VII. Operational Practices:*Drilling*

During Permian's drilling operations it is uncommon for venting or flaring to occur. If flaring is needed due to safety concerns, gas will be routed to a flare and volumes will be estimated.

Flowback

During completion/recompletion flowback operations, after separation flowback begins and as soon as it is technically feasible, Permian routes gas through a permanent separator and the controlled facility where the gas is either sold or flared through a high-pressure flare if needed.

Production

Per 19.15.27.8.D, Permian's facilities are designed to minimize waste. Our produced gas will only be vented or flared in an emergency or malfunction situation, except as allowed for normal operations noted in 19.15.27.8.D(2) & (4). All gas that is flared is metered. All gas that may be vented will be estimated.

Performance Standards

Permian utilizes a production forecast from our Reservoir Engineering team to appropriately size each permanent, 3-phase separator and heater treater utilized for production operations.

All of Permian's permanent storage tanks associated with production operations which are routed to a flare or control device are equipped with an automatic gauging system.

All of Permian's flare stacks, both currently installed and for future installation, are:

- 1) Appropriately sized and designed to ensure proper combustion efficiency.
- 2) Equipped with an automatic ignitor or continuous pilot.
- 3) Anchored and located at least 100 feet from the well and storage tanks.

Permian's field operations and HSE teams have implemented an AVO inspection schedule that adheres to the requirements of 19.15.27.8.E(5).

All of our operations and facilities are designed to minimize waste. We routinely employ the following methods and practices:

- Closed-loop systems
- Enclosed and properly sized tanks

Permian Resources Operating, LLC (372165)

- Vapor recovery units to maximize recovery of low-pressure gas streams and potential unauthorized emissions
- Low-emitting or electric engines whenever practical
- Combustors and flare stacks in the event of a malfunction or emergency
- Routine facility inspections to identify leaking components, functioning control devices, such as flares and combustors, and repair / replacement of malfunctioning components where applicable

Measurement or estimation

Permian measures or estimates the volumes of natural gas vented, flared and/or beneficially used for all of our drilling, completing and producing wells. We utilize accepted industry standards and methodology which can be independently verified. Annual GOR testing is completed on our wells and will be submitted as required by the OCD. None of our equipment is designed to allow diversion around metering elements except during inspection, maintenance and repair operations.

VIII. Best Management Practices:

Permian utilizes the following BMPs to minimize venting during active and planned maintenance activities:

- Use a closed-loop process wherever possible during planned maintenance activities, such as blowdowns, liquid removal, and work over operations.
- Employ low-emitting or electric engines for equipment, such as compressors
- Adhere to a strict preventative maintenance program which includes routine facility inspections, identification of component malfunctions, and repairing or replacing components such as hatches, seals, valves, etc. where applicable
- Utilize vapor recovery units (VRU's) to maximize recovery of volumes of low-pressure gas streams and potential unauthorized emissions
- Route low pressure gas and emissions streams to a combustion device to prevent venting where necessary

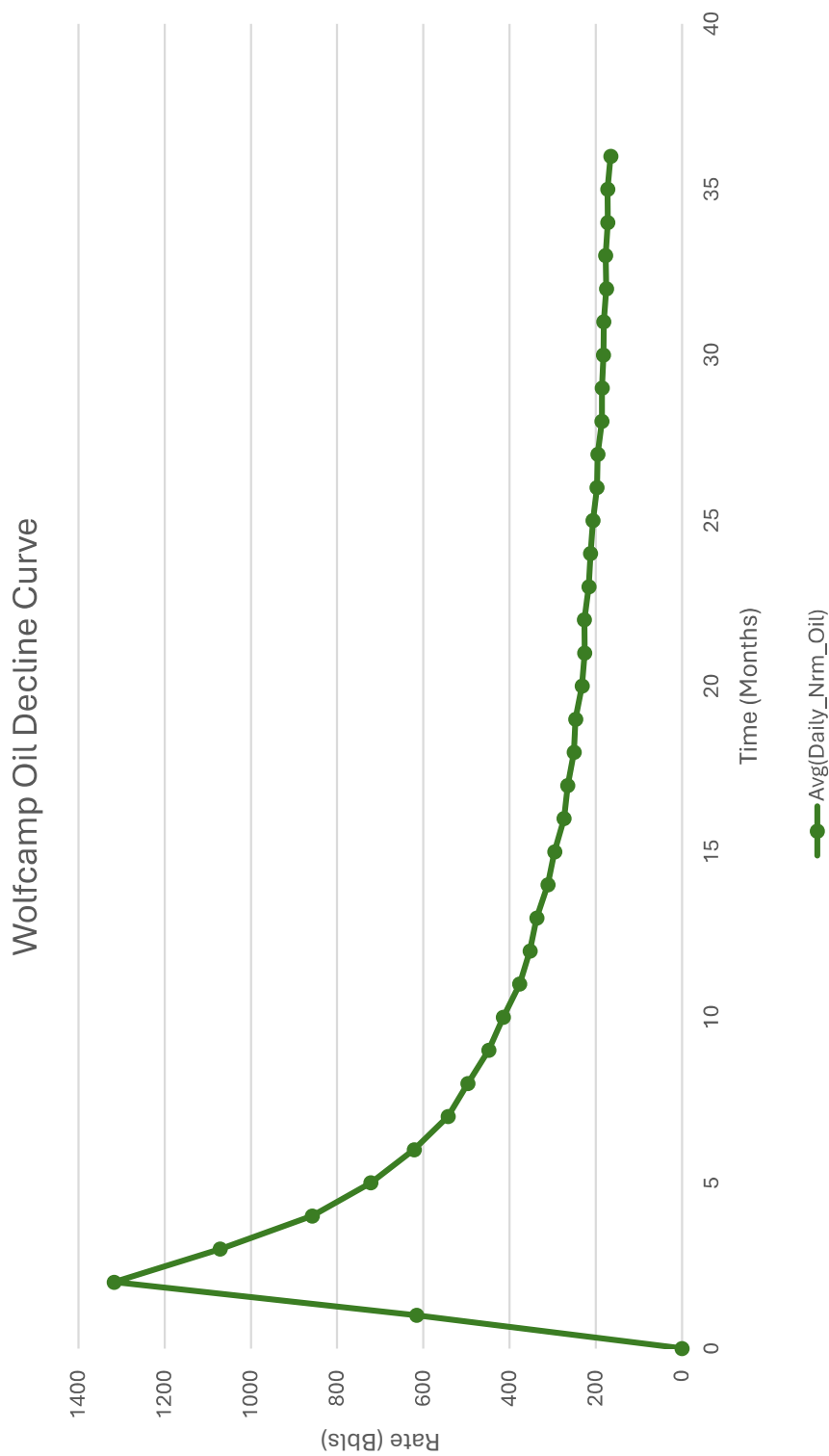

1. Represented curve is generic based on 3-Years available information for the Bone Spring formation and may not be representative of forecasted production or actual volumes.
2. Decline curves are based on an average 10,000ft lateral length. Multiple factors may influence production and decline curves, including but not limited to: lateral length and completion type.

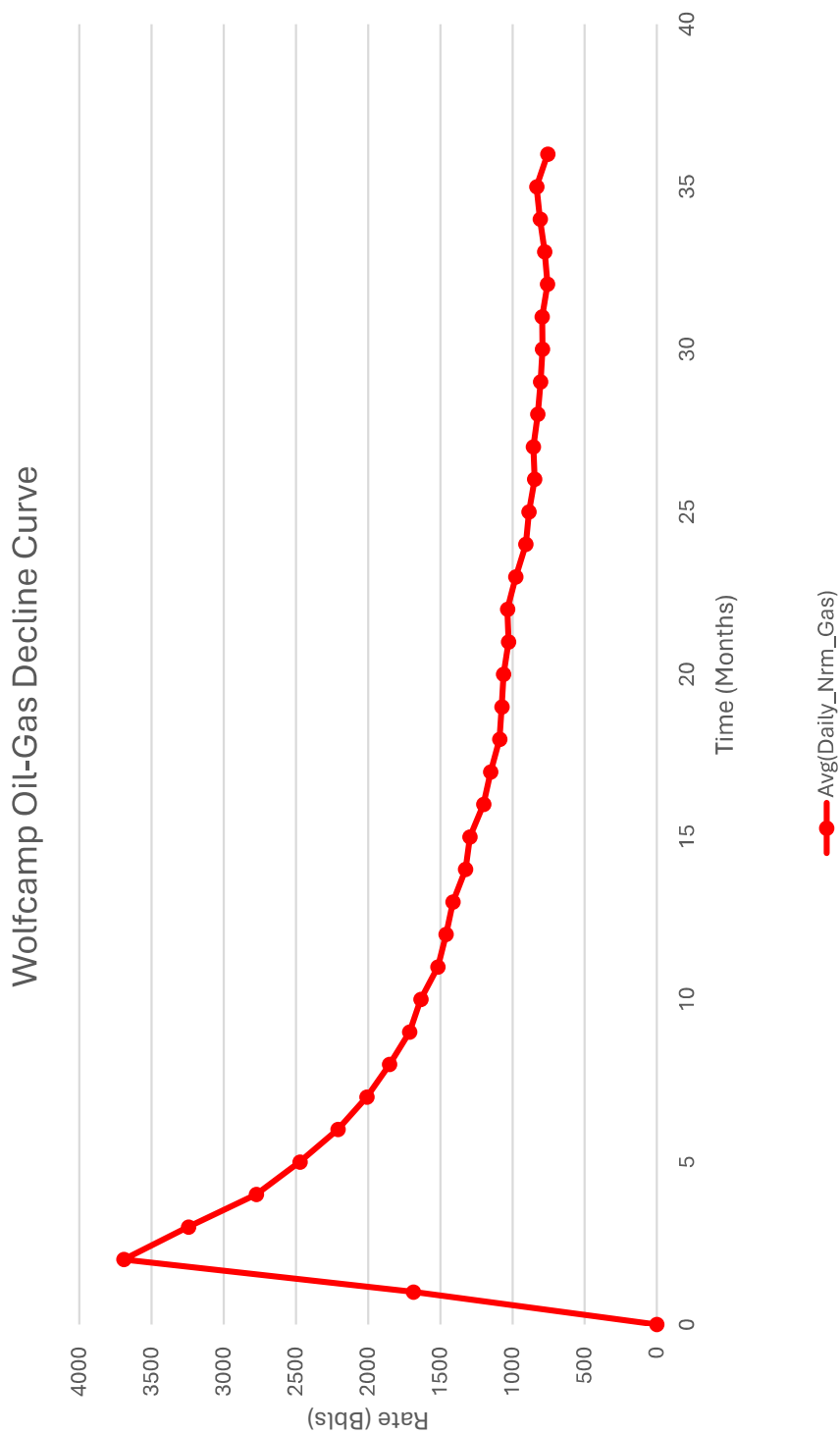

1. Represented curve is generic based on 3-Years available information for the Bone Spring formation and may not be representative of forecasted production or actual volumes.
2. Decline curves are based on an average 10,000ft lateral length. Multiple factors may influence production and decline curves, including but not limited to: lateral length and completion type.

Permian Resources Multi-Well Pad Batch Drilling Procedure

Surface Casing - PR intends to Batch set all surface casing to a depth approved in the APD. Surface Holes will be batch drilled by a rig. Appropriate notifications will be made prior to spudding the well, running and cementing casing and prior to skidding to the rig to the next well on pad.

1. Drill Surface hole to Approved Depth with Rig and perform wellbore cleanup cycles. Trip out and rack back drilling BHA.
2. Run and land planned surface casing see Illustration 1-1 Below to depth approved in APD.
3. Set packoff and test to 5k psi
4. Offline Cement
5. Install wellhead with pressure gauge and nightcap. Nightcap is shown on final wellhead Stack up Illustration #2-2.
6. Skid Rig to adjacent well to drill Surface hole.
7. Surface casing test will be performed by the rig in order to allow ample time for Cement to develop 500psi compressive strength. Casing test to 0.22 psi/ft or 1500 psi whichever is greater - not to exceed 70% casing burst.

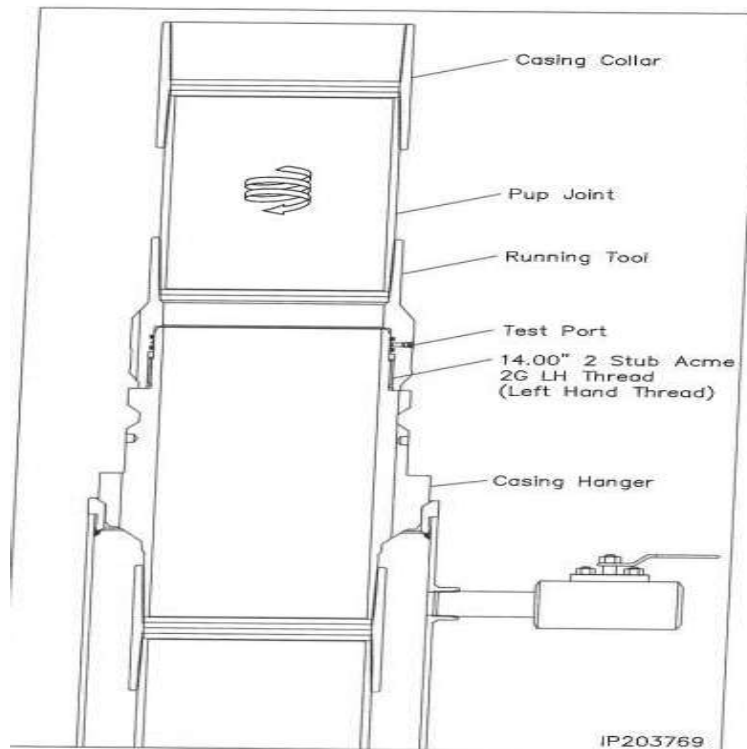

Illustration 1-1

Intermediate Casing – PR intends to Batch set all intermediate casing strings to a depth approved in the APD. Intermediate Holes will be batch drilled by the rig. Appropriate notifications will be made prior to testing BOPE, and prior to running/cementing all casing strings.

1. Rig will remove the nightcap and install and test BOPE.
2. Test Surface casing per COA WOC timing (.22 psi/ft or 1500 psi whichever is greater) - not to exceed 70% casing burst. Cement must have achieved 500psi compressive strength prior to test.
3. Install wear bushing then drill out surface casing shoe-track plus 20' and conduct FIT to minimum of the MW equivalent anticipated to control the formation pressure to the next casing point.
4. Drill Intermediate hole to approved casing point. Trip out of hole with BHA to run Casing.
5. Remove wear bushing then run and land Intermediate Casing with mandrel hanger in wellhead.
6. Cement casing to surface with floats holding.
7. Washout stack then run wash tool in wellhead and wash hanger and pack-off setting area.
8. Install pack-off and test void to 5,000 psi for 15 minutes. Nightcap shown on final wellhead stack up illustration 2-2 on page 3.
9. Test casing per COA WOC timing (.22 psi/ft or 1500 psi whichever is greater) - not to exceed 70% casing burst. Cement must have achieved 500psi compressive strength prior to test.
10. Install nightcap – skid rig to adjacent well to drill Intermediate hole.

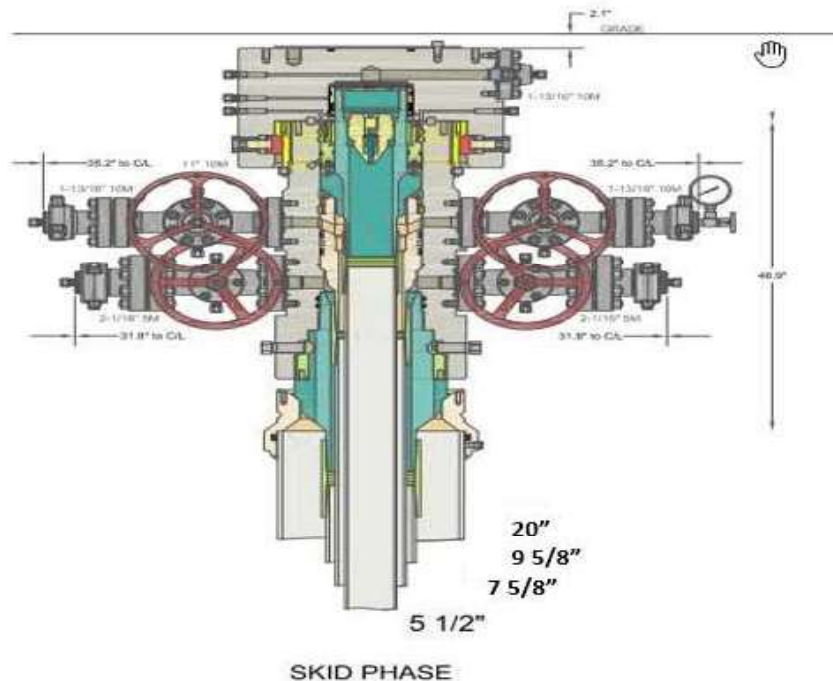

Illustration 2-2

Production Casing – PR intends to Batch set all Production casings with Rig. Appropriate notifications will be made prior Testing BOPE, and prior to running/cementing all casing strings.

1. Drilling Rig will remove the nightcap and install and test BOPE.
2. Install wear bushing then drill Intermediate shoe-track plus 20' and conduct FIT to minimum MW equivalent to control the formation pressure to TD of well.
3. Drill Vertical hole to KOP – Trip out for Curve BHA.
4. Drill Curve, landing in production interval – Trip for Lateral BHA.
5. Drill Lateral / Production hole to Permitted BHL, perform cleanup cycles and trip out to run Production Casing.
6. Remove wear bushing then run Production casing to TD landing casing mandrel in wellhead.
7. Cement Production string with floats holding.
8. Run in with wash tool and wash wellhead area – install pack-off and test void to 5,000psi for 15 minutes.
9. Install BPV in Production mandrel hanger – Nipple down BOPE and install nightcap.
10. Test nightcap void to 5,000 psi for 30 minutes per illustration 2-2
11. Skid rig to adjacent well on pad to drill production hole.

Permian Resources BOP Break Testing Variance Procedure

Subject: Request for a Variance Allowing break Testing of the Blowout Preventer Equipment (BOPE). Permian Resources requests a variance to ONLY test broken pressure seals on the BOPE and function test BOP when skidding a drilling rig between multiple wells on a pad.

Background

Title 43 CFR 3172, Drilling Operations, Sections 6.b.9.iv states that the BOP test must be performed whenever any seal subject to test pressure is broken. The current interpretation of the Bureau of Land Management (BLM) requires a complete BOP test and not just a test of the affected component. 43 CFR 3172.13, Variances from minimum standards states, "An operator may request the authorized officer to approve a variance from any of the minimum standards prescribed in [§§ 3172.6](#) through [3172.12](#). All such requests shall be submitted in writing to the appropriate authorized officer and provide information as to the circumstances which warrant approval of the variance(s) requested and the proposed alternative methods by which the related minimum standard(s) are to be satisfied. The authorized officer, after considering all relevant factors, if appropriate, may approve the requested variance(s) if it is determined that the proposed alternative(s) meet or exceed the objectives of the applicable minimum standard(s)". Permian Resources feels the break testing the BOPE is such a situation. Therefore, as per 43 CFR 3172.13, Permian Resources submits this request for the variance.

Supporting Documentation

The language used in 43 CFR 3172 became effective on December 19, 1988 and has remained the standard for regulating BLM onshore drilling operations for over 30 years. During this time, there have been significant changes in drilling technology. The BLM continues to use the variance request process to allow for the use of modern technology and acceptable engineering practices that have arisen since 43 CFR 3172 was originally released. The Permian Resources drilling rig fleet has many modern upgrades that allow the intact BOP stack to be moved between well slots on a multi-well pad, as well as, wellhead designs that incorporate quick connects facilitating release of the BOP from the wellhead without breaking any BOP stack components apart. These technologies have been used extensively offshore, and other regulators, API, and many operators around the world have endorsed break testing as safe and reliable.

Figure 1: Winch System attached to BOP Stack



Figure 2: BOP Winch System



American Petroleum Institute (API) standards, specification and recommended practices are considered the industry standard and are consistently utilized and referenced by the industry. 43 CFR 3172 recognizes API recommended Practices (RP) 53 in its original development. API Standard 53, Well Control Equipment Systems for Drilling Wells (Fifth Edition, December 2018, Annex C, Table C.4) recognizes break testing as an acceptable practice. Specifically, API Standard 53, Section 5.3.7.1 states "A pressure test of the pressure containing component shall be performed following the disconnection or repair, limited to the affected component." See Table C.4 below for reference.

62 API STANDARD 53			
Table C.4—Initial Pressure Testing, Surface BOP Stacks			
Component to be Pressure Tested	Pressure Test—Low Pressure ^a psig (MPa)	Pressure Test—High Pressure ^{a,c}	
		Change Out of Component, Elastomer, or Ring Gasket	No Change Out of Component, Elastomer, or Ring Gasket
Annular preventer ^b	250 to 350 (1.72 to 2.41)	RWP of annular preventer	MASP or 70% annular RWP, whichever is lower.
Fixed pipe, variable bore, blind, and BSR preventers ^b	250 to 350 (1.72 to 2.41)	RWP of ram preventer or wellhead system, whichever is lower	ITP
Choke and kill line and BOP side outlet valves below ram preventers (both sides)	250 to 350 (1.72 to 2.41)	RWP of side outlet valve or wellhead system, whichever is lower	ITP
Choke manifold—upstream of chokes ^a	250 to 350 (1.72 to 2.41)	RWP of ram preventers or wellhead system, whichever is lower	ITP
Choke manifold—downstream of chokes ^a	250 to 350 (1.72 to 2.41)	RWP of valve(s), line(s), or MASP for the well program, whichever is lower	
Kelly, kelly valves, drill pipe safety valves, IBOPs	250 to 350 (1.72 to 2.41)	MASP for the well program	

^a Pressure test evaluation periods shall be a minimum of five minutes. No visible leaks. The pressure shall remain stable during the evaluation period. The pressure shall not decrease below the intended test pressure.

^b Annular(s) and VBR(s) shall be pressure tested on the largest and smallest OD drill pipe to be used in well program.

^c For pad drilling operations, moving from one wellhead to another within the 21 days, pressure testing is required for pressure-containing and pressure-controlling connections when the integrity of a pressure seal is broken.

^d For surface offshore operations, the ram BOPs shall be pressure tested with the ram locks engaged and the closing and locking pressure vented during the initial test. For land operations, the ram BOPs shall be pressure tested with the ram locks engaged and the closing and locking pressure vented at commissioning and annually.

^e Adjustable chokes are not required to be full sealing devices. Pressure testing against a closed choke is not required.

The Bureau of Safety and Environmental Enforcement (BSEE), Department of Interior, has also utilized the API standards, specification and best practices in the development of its offshore oil and gas regulations and incorporates them by reference within its regulations.

Break testing has been approved by the BLM in the past with other operators based on the detailed information provided in this document.

Permian Resources feels break testing and our current procedures meet the intent of 43 CFR 3172 and often exceed it. There has been no evidence that break testing results in more components failing than seen on full BOP tests. Permian Resources internal standards require complete BOPE tests more often than that of 43 CFR 3172 (every 21 days). In addition to function testing the annular, pipe rams and blind rams after each BOP nipple up, Permian Resources performs a choke drill with the rig crew prior to drilling out every casing shoe. This is additional training for the rig crew that exceeds the requirements of 43 CFR 3172.

Procedures

- 1) Permian Resources will use this document for our break testing plan for New Mexico Delaware Basin. The summary below will be referenced in the APD or Sundry Notice and receive approval prior to implementing this variance.
- 2) Permian Resources will perform BOP break testing on multi-wells pads where multiple intermediate sections can be drilled and cased within the 21-day BOP test window.
 - a) A full BOP test will be conducted on the first well on the pad.
 - b) The first intermediate hole section drilled on the pad will be the deepest. All the remaining hole sections will be the same formation depth or shallower.
 - c) A full BOP test will be required if the intermediate hole section being drilled has a MASP over 5M.
 - d) A full BOP test will be required prior to drilling any production hole.
- 3) After performing a complete BOP test on the first well, the intermediate hole section will be drilled and cased, two breaks would be made on the BOP equipment.
 - a) Between the HCV valve and choke line connection
 - b) Between the BOP quick connect and the wellhead
- 4) The BOP is then lifted and removed from the wellhead by a hydraulic system.
- 5) After skidding to the next well, the BOP is moved to the wellhead by the same hydraulic system and installed.
- 6) The connections mentioned in 3a and 3b will then be reconnected.
- 7) Install test plug into the wellhead using test joint or drill pipe.
- 8) A shell test is performed against the upper pipe rams testing the two breaks.
- 9) The shell test will consist of a 250 psi low test and a high test to the value submitted in the APD or Sundry (e.g. 5,000 psi or 10,000psi).
- 10) Function tests will be performed on the following components: lower pipe rams, blind rams, and annular.
- 11) For a multi-well pad the same two breaks on the BOP would be made and on the next wells and steps 4 through 10 would be repeated.
- 12) A second break test would only be done if the intermediate hole section being drilled could not be completed within the 21 day BOP test window.

Note: Picture below highlights BOP components that will be tested during batch operations

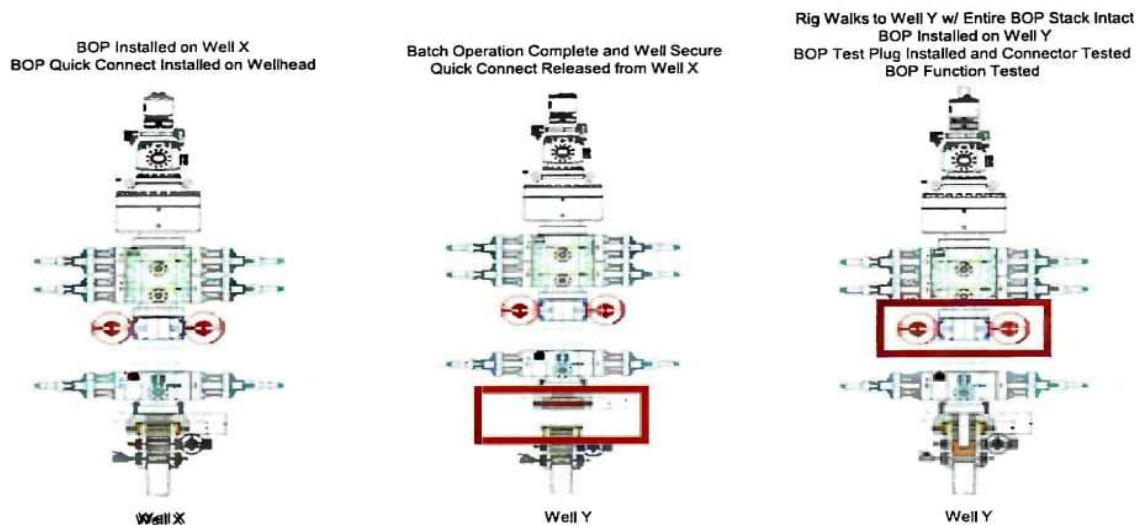

Summary

A variance is requested to ONLY test broken pressure seals on the BOP equipment when moving from wellhead to wellhead which is in compliance with API Standard 53. API Standard 53 states, that for pad drilling operations, moving from one wellhead to another within 21 days, pressure testing is required for pressure-containing and pressure-controlling connections when the integrity of a pressure seal is broken.

The BOP will be secured by a hydraulic carrier or cradle. The BLM will be contacted if a Well Control event occurs prior to the commencement of a BOPE Break Testing operation.

Based on public data and the supporting documentation submitted herein to the BLM, we will request permission to ONLY retest broken pressure seals if the following conditions are met:

- 1) After a full BOP test is conducted on the first well on the pad.
- 2) The first intermediate hole section drilled on the pad will be the deepest. All the remaining hole sections will be the same depth or shallower.
- 3) A full BOP test will be required if the intermediate hole section being drilled has a MASP over 5M.
- 4) A full BOP test will be required prior to drilling the production hole.

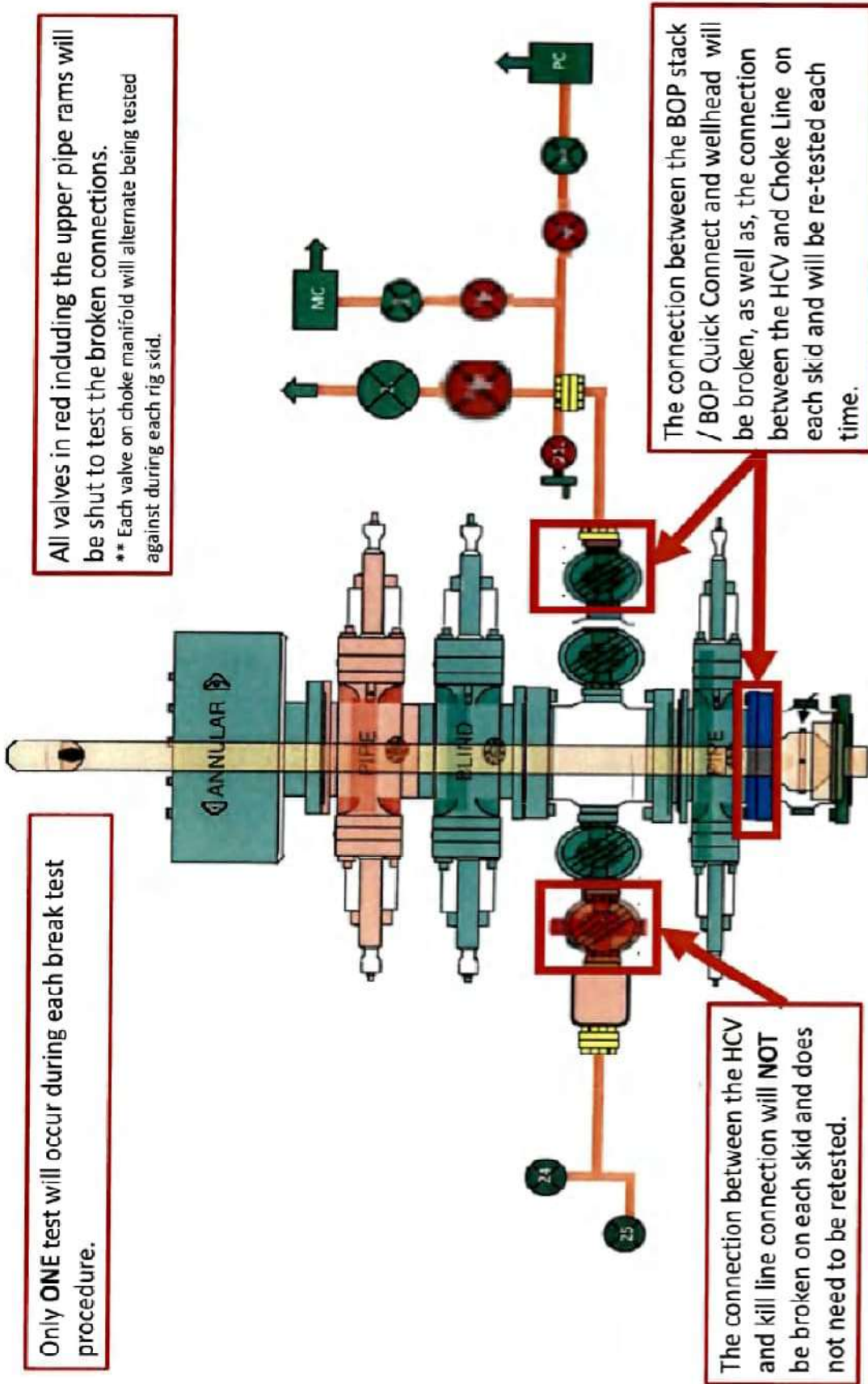

Only **ONE** test will occur during each break test procedure.

All valves in red including the upper pipe rams will be shut to test the broken connections.
** Each valve on choke manifold will alternate being tested against during each rig skid.

The connection between the BOP stack / BOP Quick Connect and wellhead will be broken, as well as, the connection between the HCV and Choke Line on each skid and will be re-tested each time.

The connection between the HCV and kill line connection will **NOT** be broken on each skid and does not need to be retested.



ContiTech Fluid Technology

ContiTech Oil & Marine Corp. # 11535 Brittnmoore Park Dr., Houston, TX 77041-6916 USA		Packing list / Delivery note	
CONSIGNEE / Ship-to address: HELMERICH & PAYNE INT'L DRILLING CO ATTN: FLEX RIG WHSE - B-BAY 210 MAGNOLIA DRIVE GALENA PARK TX 77547		Document No. 71461553 Document Date 28.01.2022	Customer Number 11697 Customer VAT No. Supplier Number Purchase Order No. 740362040 Purchase Order Date 18.01.2022 Sales Order Number 1388153 Sales Order Date 18.01.2022
Buyer: HELMERICH & PAYNE INT'L DRILLING CO 1437 SOUTH BOULDER 74119 TULSA		Unloading Point RAN-No.	
Conditions Incoterms EXW Houston Ex Works		Page 1 of 2 Weights (Gross / Net) Total Gross Weight 2,507.000 LB Total Net Weight 2,507.000 LB	

Item	Material/Description	Quantity	Net Weight	Gross Weight
20	Buyer: Jack Peebles E-mail: Jackie.Peebles@hpinc.com Tel: 832-782-6000 Rig/Whse: HOW 00RECERTIFY Recert of HP Hoses Serial# 67094 Commodity Code: 3" X 35 FT 10K Choke & Kill Hoses API 16C End 1: 4 - 1/16" 10Kpsi API Spec 6A Type 6BX Flange End 2: 4 - 1/16" 10Kpsi API Spec 6A Type 6BX Flange c/w BX155 ring groove each end Standard: API Spec 16C - Monogrammed Working Pressure: 10,000psi Test Pressure: 15,000psi Inspection & Certification includes: External inspection of the hose & couplings Internal boroscopic inspection of hose liner Hydrostatic pressure test of hose assembly Repair of any external damage to hose body and end connections (limited to minor repairs). Clean & protect end connections Inspection Report Disposal of hose assembly if hose fails inspection and recertification process. Please Flush Hoses before sending them to our Facility.	1 PC	2,507.000 LB	2,507.000 LB

88000240
 1106-01-0101
 2-9-22

ContiTech Rubber Industrial Kft
 H-6728 Szeged Budapesti út 10.
 P. O. Box 152 Szeged H-6701
 Phone: (62)566-700, Fax: (62)566-713
 Tax Number: 11087209-2-06
 EU Community VAT: HU11087209
 Registration No.: Cg. 0609-002502
 Registry Court: Csongrád Megyei Cégbíróság

COMMERZBANK ZRT. (HUF)
 H-1054 Budapest, Széchenyi rakpart 8.
 H-1245 Budapest P.O. Box 1070
 Account No. 14220108-26830003
 IBAN: HU83 1422 0108 2683 0003 0000 0000
 SWIFT: COBA HU HXXX

COMMERZBANK AG Hannover (EUR)
 30159 Hannover, Theaterstr. 11-12.
 Account No.: 3 066 156 00
 Sort Code: 250 400 66
 BIC: COBADEFF250
 IBAN: DE41250400660306615600

Record Rotary Hose sleeve number on the CBC Made Hose List!!!!!!!!!!!!!!!!!!!!!!!!!!!!!!!!!!!!



Hydrostatic Test Certificate

ContiTech

Certificate Number H100122	COM Order Reference 1388153	Customer Name & Address	
Customer Purchase Order No: 740362040		HELMERICH & PAYNE DRILLING CO 1434 SOUTH BOULDER AVE TULSA, OK 74119 USA	
Project:			
Test Center Address	Accepted by COM Inspection	Accepted by Client Inspection	
ContiTech Oil & Marine Corp. 11535 Brittmooore Park Drive Houston, TX 77041 USA	Signed: Gerson Mejia-Lazo Date: 02/09/22		

We certify that the goods detailed hereon have been inspected as described below by our Quality Management System, and to the best of our knowledge are found to conform the requirements of the above referenced purchase order as issued to ContiTech Oil & Marine Corporation.

Item	Part No.	Description	Qty	Serial Number	Work. Press. (psi)	Test Press. (psi)	Test Time (minutes)
------	----------	-------------	-----	---------------	--------------------	-------------------	---------------------

20	RECERTIFICATION	3" ID 10K Choke and Kill Hose x 35ft OAL	1	67094	10,000	15,000	60
----	-----------------	--	---	-------	--------	--------	----

Record Information	
Start Time	1/27/2022 13:21:21
End Time	1/27/2022 14:38:28
Interval	00:01:00
Number	78
MaxValue	15849
MinValue	-3
AvgValue	14240
RecordName	67094-sh
RecordNumber	199

Gauge Information	
Model	ADT680
SN	21817380014
Range	(0-40000)psi
Unit	psi

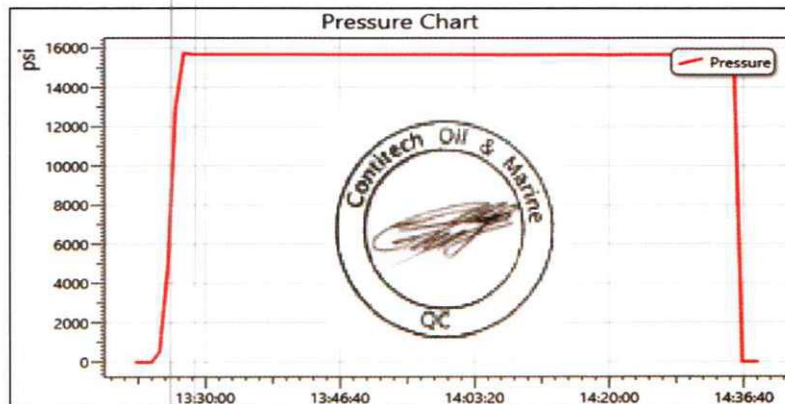

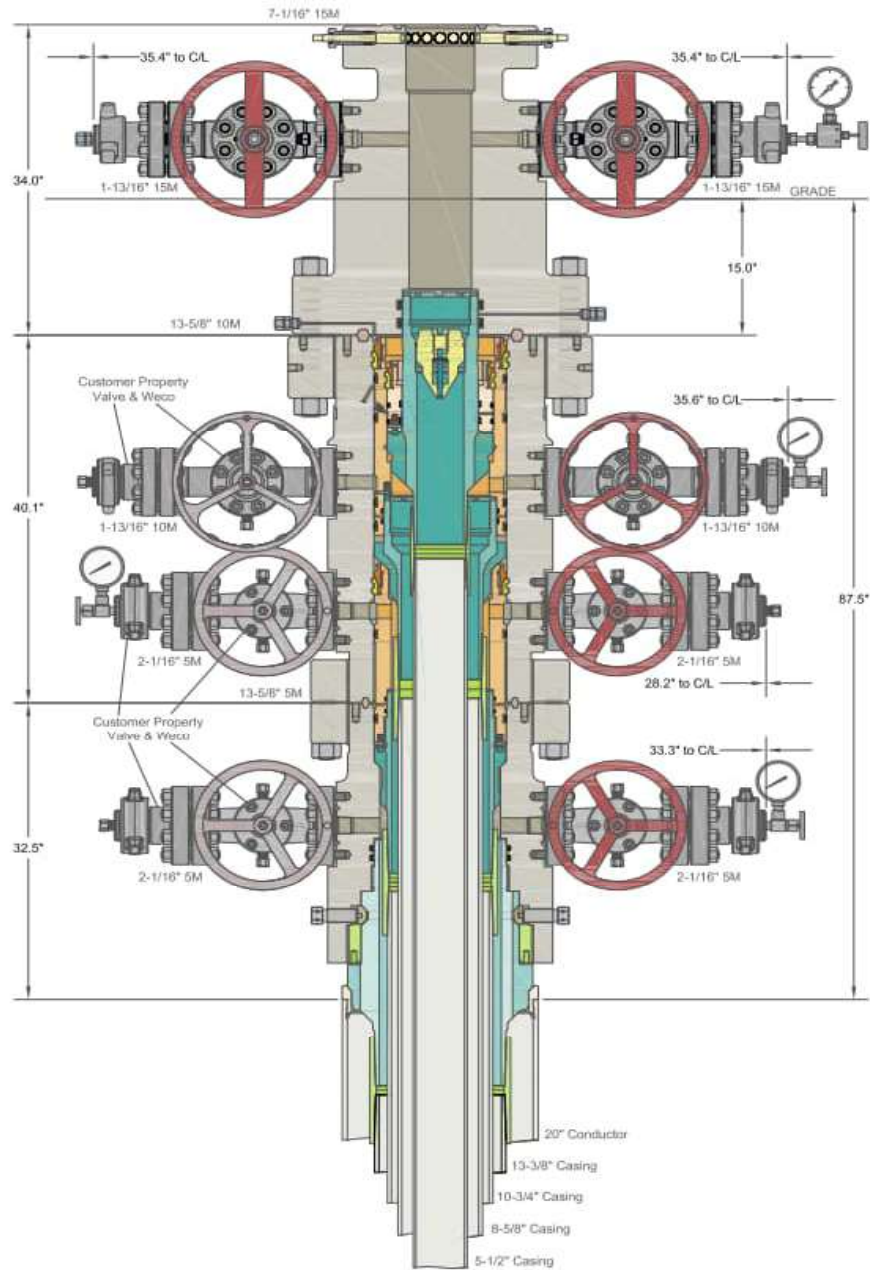

INFORMATION CONTAINED HEREIN IS THE PROPERTY OF CACTUS WELLHEAD, LLC. REPRODUCTION, DISCLOSURE, OR USE THEREOF IS PERMISSIBLE ONLY AS PROVIDED BY CONTRACT OR AS EXPRESSLY AUTHORIZED BY CACTUS WELLHEAD, LLC.

ALL DIMENSIONS APPROXIMATE

CACTUS WELLHEAD LLC

PERMIAN RESOURCES
NEW MEXICO

20" x 13-3/8" x 10-3/4" x 8-5/8" x 5-1/2" MBU-4T-CFL-R-DBLO Sys.
With 13-5/8" 10M x 7-1/16" 15M CTH-DBLHPS Tubing Head
And 10-3/4" & 7-5/8" & 5-1/2" Fluted Mandrel Casing Hangers

DRAWN	DLE	26OCT23
APPRV		
DRAWING NO.	HBE0001038	

**Permian Resources Offline Cementing Procedure
Surface & Intermediate Casing**

1. Drill hole to Total Depth with Rig and perform wellbore cleanup cycles.
2. Run and casing to Depth.
3. Land casing with mandrel.
4. Circulate 1.5 csg capacity.
5. Flow test – Confirm well is static and floats are holding.
6. Set Annular packoff and pressure test. Test to 5k.
7. Nipple down BOP and install cap flange.
8. Skid rig to next well on pad
9. Remove cap flange (confirm well is static before removal)
 - a) If well is not static use the casing outlet valves to kill well
 - b) Drillers method will be used in well control event
 - c) High pressure return line will be rigged up to lower casing valve and run to choke manifold to control annular pressure
 - d) Kill mud will be circulated once influx is circulated out of hole
 - e) Confirm well is static and remove cap flange to start offline cement operations
10. Install offline cement tool.
11. Rig up cementers.
12. Circulate bottoms up with cement truck
13. Commence planned cement job, take returns through the annulus wellhead valve
14. After plug is bumped confirm floats hold and well is static
15. Rig down cementers and equipment
16. Install night cap with pressure gauge to monitor.

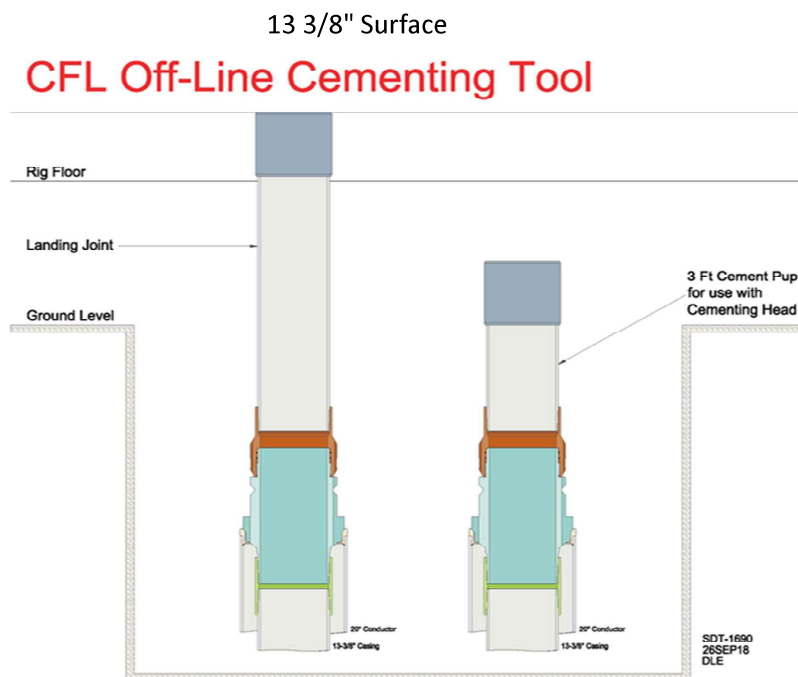

Intermediate

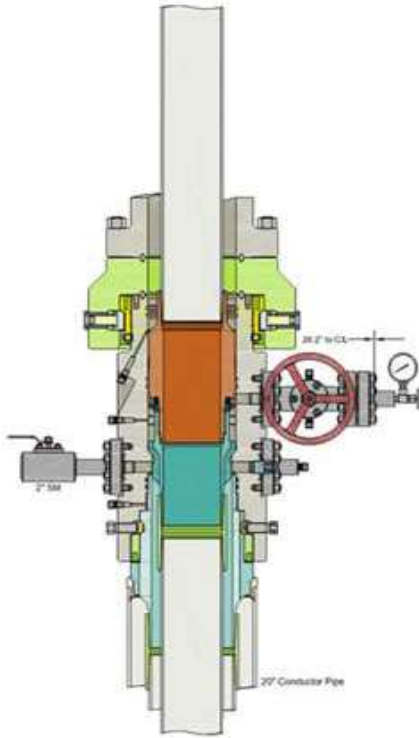

Run 7 5/8" Casing
Land Casing on 7 5/8" Mandrel Hanger
Cement 7 5/8" Casing
Retrieve Running Tool

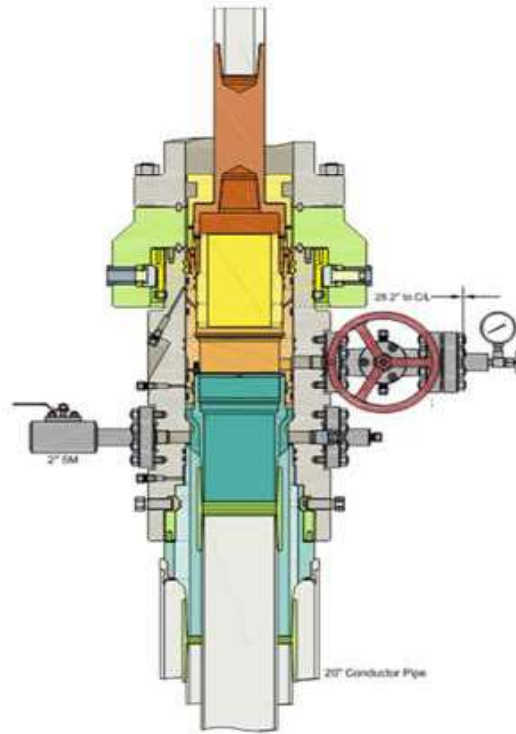

Run 9 5/8" Packoff
Test Upper and Lower Seals
Engage Lockring
Retrieve Running Tool

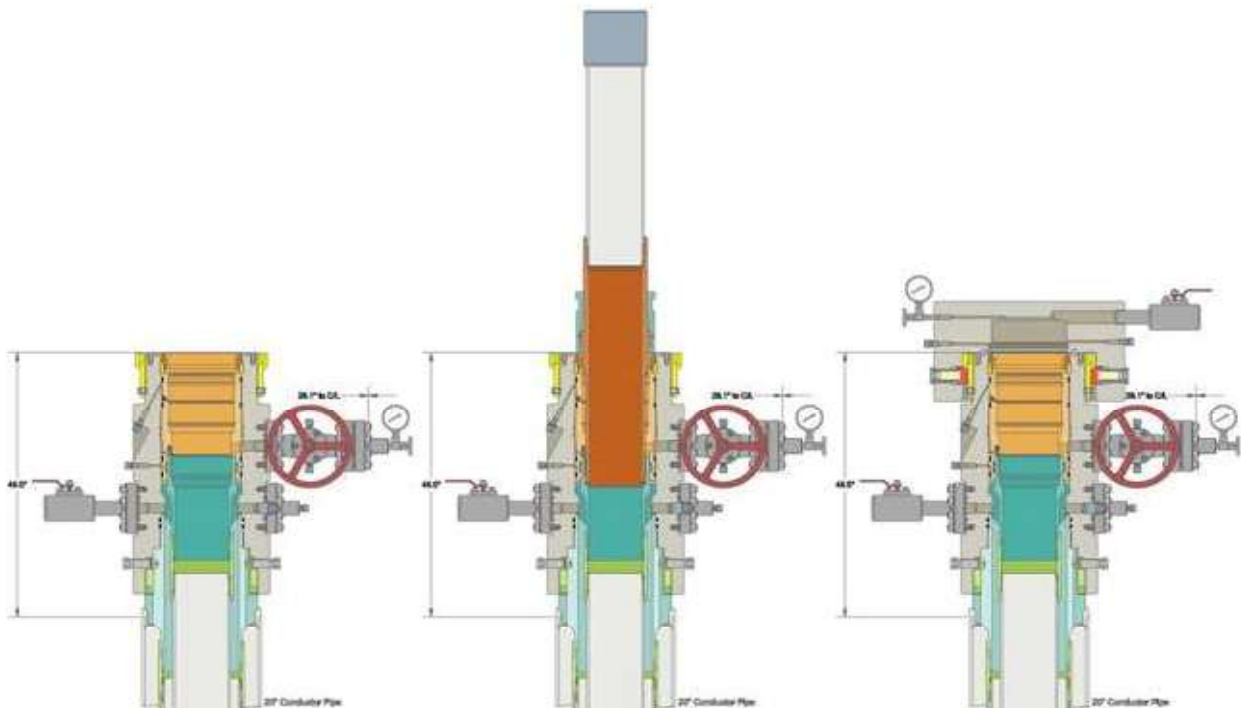



Well Name: KOALA 9 FED COM

Well Number: 124H

Section 3 - Location of Existing Wells

Existing Wells Map? YES

Existing Well map Attachment:

Koala_9_Fed_Com_1mile_20251029111950.pdf

Section 4 - Location of Existing and/or Proposed Production Facilities

Submit or defer a Proposed Production Facilities plan? SUBMIT

Production Facilities description: Production Facilities. CTB was constructed and all production from the Koala wells will go to the Dundee 4 Fed Com CTB located in the SESE of Section 5-T20S-R28E, NMPM, Eddy County, New Mexico. Centerpoint: 826 FSL, 150 FEL. t of the CTB is attached, no new surface disturbance is requested. We will be using the approved facility pad (Dundee 4) under EA: DOI-BLM-NM-P020-2022-1018-EA. Buried & Surface Flowlines. No additional surface disturbance anticipated. Buried four-inch (4) OD HDPE FL and a Three-Inch (3) OD HDPE gas line will run North for 6097.93 between the Koala South Pad and the CTB, and 1195.68 between the Koala North Pad to the CTB. Trenches will be parallel to the Koala North Pad Roads. Permian Resources will be utilizing the existing flowline corridor approved with the original Koala 9 Fed Com permits, under EA: DOI-BLM-NM-P020-2022-1018-EA. Midstream Tie-In. A midstream tie-in is not requested with this project. In the event that a midstream tie-in is necessary, Permian Resources will file application with the appropriate authorities to construct via right-of-way. Disposal Facilities. Produced water will be hauled from location to a commercial disposal facility as needed. Once wells are drilled and completed, a 3160-5 sundry notification will be submitted to BLM in compliance with Onshore Order 7. Flare. A flare is not requested with this project. The flare is collocated on the Dundee 4 Fed Com CTB. No additional surface disturbance is requested. Aboveground Structures. All permanent (on site six months or longer) aboveground structures constructed or installed on location and not subject to safety requirements will be painted earth-tone colors such as shale green that reduce the visual impacts of the built environment. Containment Berms. Containment berms will be constructed completely around any production facilities designed to hold fluids. The containment berms will be constructed of compacted subsoil, be sufficiently impervious, hold 1.5 times the capacity of the largest tank and away from cut or fill areas. Electrical. Electrical is routed to the well pad and central tank battery locations. No additional surface disturbance is requested or anticipated. In the event that an electrical line is identified and determined to be necessary, Permian Resources will submit the appropriate documentation to the BLM utilizing either SF-299 or 3160-5 to be determined by future route.

Production Facilities map:

Dundee_4_Fed_Com_CTB_Pad_20251029112008.pdf

Koala_9_Fed_Com_FL_20251030121058.pdf

Section 5 - Location and Types of Water Supply

Water Source Table

Water source type: OTHER

Describe type: Fresh & Recycled Water Water for drilling, completion and dust control will be purchased & supplied by a third party and stored in the Ranger Pit located SESE, Section 22, T20S, R33E, Lea County, New Mexico

Water source use type: DUST CONTROL
SURFACE CASING
INTERMEDIATE/PRODUCTION CASING

Well Name: KOALA 9 FED COM

Well Number: 124H

STIMULATION

Source latitude:

Source longitude:

Source datum:

City:

Water source permit type: PRIVATE CONTRACT

Water source transport method: PIPELINE

TRUCKING

Source land ownership: PRIVATE

Source transportation land ownership: FEDERAL

Water source volume (barrels): 1950000

Source volume (acre-feet): 251.34153785

Source volume (gal): 81900000

Water source and transportation

Koala_9_Fed_Com_Water_20251029112107.pdf

Water source comments: The well will be drilled using a combination of water mud systems as outlined in the Drilling Program. The water will be obtained from a 3rd party vendor and hauled to the anticipated pit by transport truck using the existing and proposed roads depicted in the attached exhibits. No water well will be drilled on the location. Water for drilling, completion and dust control will be used from the following existing lined pond. Water for drilling, completion and dust control will be supplied by existing Alfadale water station on private land in SESW 6-T19S-R28E. Anticipated water usage for drilling includes an estimated 50,000 barrels (bbls) of water to drill a horizontal well in a combination of fresh water and brine as detailed in the mud program in the drilling plans. These volumes are calculated for ~1.5 bbls per foot of hole drilled with excess to accommodate any lost circulation or wash out that may occur. Actual water volumes used during operations will depend on the depth of the well, length of horizontal sections, and the losses that may occur during the operation. Temporary water flowlines will be permitted via ROW approval letter and proper grants as needed based on drilling and completion schedules. Well completion is expected to require approximately 1,950,000 bbls of water per horizontal well. Actual water volumes used during operations will depend on the depth of the well and length of horizontal sections.

New water well? N

New Water Well Info

Well latitude:

Well Longitude:

Well datum:

Well target aquifer:

Est. depth to top of aquifer(ft):

Est thickness of aquifer:

Aquifer comments:

Aquifer documentation:

Well depth (ft):

Well casing type:

Well casing outside diameter (in.):

Well casing inside diameter (in.):

New water well casing?

Used casing source:

Well Name: KOALA 9 FED COM

Well Number: 124H

Drilling method:

Drill material:

Grout material:

Grout depth:

Casing length (ft.):

Casing top depth (ft.):

Well Production type:

Completion Method:

Water well additional information:

State appropriation permit:

Additional information attachment:

Section 6 - Construction Materials

Using any construction materials: YES

Construction Materials description: A. Construction, reclamation, and/or routine maintenance will not be conducted during periods when the soil conditions for construction could lead to impacts to the surrounding environment, or when watershed damage is likely to occur because of these activities. B. Any construction material that may be required for surfacing of the drill pad and access road will be from a contractor having a permitted source of materials within the general area. No construction materials will be removed from federal lands without prior approval from the appropriate surface management agency. All roads and well pads will be constructed of 6 rolled and compacted caliche hauled by Constructors Inc. C. Anticipated Caliche Locations: a. Pit 1: Private Caliche Pit, Section 18-T18S-R28E, SENE

Construction Materials source location

Koala_9_Fed_Com_Calichie_20251029112155.pdf

Section 7 - Methods for Handling

Waste type: DRILLING

Waste content description: Fluid

Amount of waste: 500 barrels

Waste disposal frequency : One Time Only

Safe containment description: Steel mud boxes

Safe containmant attachment:

Waste disposal type: HAUL TO COMMERCIAL FACILITY **Disposal location ownership:** COMMERCIAL

Disposal type description:

Disposal location description: R360 Environmental Solutions 4507 W Carlsbad Hwy, Hobbs, NM 88240

Waste type: GARBAGE

Waste content description: Trash

Amount of waste: 250 pounds

Waste disposal frequency : Weekly

Safe containment description: All garbage, junk and non-flammable waste materials will be contained in a self-contained, portable dumpster or trash cage, to prevent scattering and will be removed and deposited in an approve sanitary landfill. Immediately after drilling all debris and other waste materials on and around the well location not contained in the trash cage will be cleaned up and removed from the location. No potentially adverse materials or substances will be left on the location.

Well Name: KOALA 9 FED COM

Well Number: 124H

Safe containmant attachment:

Waste disposal type: HAUL TO COMMERCIAL FACILITY **Disposal location ownership:** COMMERCIAL FACILITY

Disposal type description:

Disposal location description: A licensed 3rd party contractor will be used to haul and dispose of garbage.

Waste type: SEWAGE

Waste content description: Human Waste

Amount of waste: 250 gallons

Waste disposal frequency : Weekly

Safe containment description: Portable, self-contained toilets will be provided for human waste disposal. Upon completion of drilling and completion activities, or as required, the toilet holding tanks will be pumped and the contents thereof disposed of in an approved sewage disposal facility. All state and local laws and regulations pertaining to the disposal of human and solid waste will be complied with. This equipment will be properly maintained during the drilling and completion operations and will be removed when all operations are complete.

Safe containmant attachment:

Waste disposal type: HAUL TO COMMERCIAL FACILITY **Disposal location ownership:** COMMERCIAL FACILITY

Disposal type description:

Disposal location description: A licensed 3rd party contractor to haul and dispose of human waste.

Waste type: DRILLING

Waste content description: Cuttings

Amount of waste: 2100 pounds

Waste disposal frequency : One Time Only

Safe containment description: The well will be drilled utilizing a closed-loop mud system. Drill cuttings will be held in roll-off style mud boxes and taken to a New Mexico Oil Conservation Division (NMOCD) approved disposal site.

Safe containmant attachment:

Waste disposal type: HAUL TO COMMERCIAL FACILITY **Disposal location ownership:** COMMERCIAL FACILITY

Disposal type description:

Disposal location description: R360 Environmental Solutions 4507 W Carlsbad Hwy, Hobbs, NM 88240

Reserve Pit

Reserve Pit being used? NO

Temporary disposal of produced water into reserve pit? NO

Reserve pit length (ft.) **Reserve pit width (ft.)**

Reserve pit depth (ft.) **Reserve pit volume (cu. yd.)**

Well Name: KOALA 9 FED COM

Well Number: 124H

Is at least 50% of the reserve pit in cut?

Reserve pit liner

Reserve pit liner specifications and installation description

Cuttings Area

Cuttings Area being used? NO

Are you storing cuttings on location? Y

Description of cuttings location Cuttings: The well will be drilled utilizing a closed-loop mud system. Drill cuttings will be held in roll-off style mud boxes and taken to a New Mexico Oil Conservation Division (NMOCD) approved disposal site. Drilling Fluids: These will be contained in steel mud pits and then taken to a NMOCD approved commercial disposal facility. Produced Fluids: Water produced from the well during completion will be held temporarily in steel tanks and then taken to a NMOCD approved commercial disposal facility. Oil produced during operations will be stored in tanks until sold.

Cuttings area length (ft.)

Cuttings area width (ft.)

Cuttings area depth (ft.)

Cuttings area volume (cu. yd.)

Is at least 50% of the cuttings area in cut?

Cuttings area liner

Cuttings area liner specifications and installation description

Section 8 - Ancillary

Are you requesting any Ancillary Facilities?: N

Ancillary Facilities

Comments:

Section 9 - Well Site

Well Site Layout Diagram:

Koala_9_Fed_Com_South_RL_20251029124159.pdf

KOALA_9_FED_COM_South_WSL_20251029124159.pdf

Comments: 1. Rig Plat Diagrams: No additional surface disturbance is requested or anticipated. The well will be located on an existing well pad previously approved under DOI-BLM-NM-P020-2022-1018-EA. There are 8 wells proposed on the well two (2) well pads with this application. The existing pad will allow enough space for cuts and fills, topsoil storage, and storm water control and sizes are approximations based on these needs. Interim reclamation of this pad is anticipated after the drilling and completion of all wells on the pad. The well site layout for the pad indicating temporary workspace and topsoil stockpile location is attached. Pad 1 Permitted Pad Size in EA: 500x500 (5.740 Acres) Center Point: 864 FNL, 477 FEL, NENE-Sec 8-T20S-R28E Pad 1 Permitted Pad Size in EA: 500x500 (5.740 Acres) Center Point: 1074 FSL, 250 FEL, SESE-Sec 8-T20S-R28E

Well Name: KOALA 9 FED COM

Well Number: 124H

Section 10 - Plans for Surface

Type of disturbance: No New Surface Disturbance **Multiple Well Pad Name:** Koala South Pad

Multiple Well Pad Number: 2

Recontouring

Koala_9_Fed_Com_North_Pad_IR_20251029112647.pdf

Koala_9_Fed_Com_South_Pad_IR_20251029112647.pdf

Drainage/Erosion control construction: Initial seedbed preparation will consist of recontouring to the appropriate interim or final reclamation standard. All compacted areas to be seeded will be ripped to a minimum depth of 18 inches with a minimum furrow spacing of 2 feet, followed by recontouring the surface and then evenly spreading the stockpiled topsoil. Prior to seeding, the seedbed will be scarified to a depth of no less than 4-6 inches.

Drainage/Erosion control reclamation: Erosion features are equal to or less than surrounding area and erosion control is sufficient so that water naturally infiltrates into the soil and gullying, headcutting, slumping, and deep or excessive rills (greater than 3 inches) are not observed.

Well pad proposed disturbance (acres):	Well pad interim reclamation (acres): 0	Well pad long term disturbance (acres): 0
Road proposed disturbance (acres):	Road interim reclamation (acres): 0	Road long term disturbance (acres): 0
Powerline proposed disturbance (acres):	Powerline interim reclamation (acres): 0	Powerline long term disturbance (acres): 0
Pipeline proposed disturbance (acres):	Pipeline interim reclamation (acres): 0	Pipeline long term disturbance (acres): 0
Other proposed disturbance (acres):	Other interim reclamation (acres): 0	Other long term disturbance (acres): 0
Total proposed disturbance: 0	Total interim reclamation: 0	Total long term disturbance: 0

Disturbance Comments:

Reconstruction method: The original stock piled topsoil will be spread over the areas being reclaimed and the original landform will be restored for all disturbed areas including well pads, production facilities, roads, pipelines, and utility corridors as close as possible to the original topography. The location will then be ripped and seeded.

Topsoil redistribution: The original stock piled topsoil will be spread over the areas being reclaimed and the original landform will be restored for all disturbed areas including well pads, production facilities, roads, pipelines, and utility corridors as close as possible to the original topography. The location will then be ripped and seeded.

Soil treatment: A self-sustaining, vigorous, diverse, native (or otherwise approved) plant community will be established on the site with a density sufficient to control erosion and invasion by non-native plants and to re-establish wildlife habitat or forage production. At a minimum, the established plant community will consist of species included in the seed mix and/or desirable species occurring in the surrounding natural vegetation.

Existing Vegetation at the well pad: Soils are classified as Reeves soils. These soils are associated with the loamy ecological site which typically supports black and blue grama and tobosa grasslands with an even distribution of yucca, mesquite, American tarbush, cholla, and creosote.

Existing Vegetation at the well pad

Existing Vegetation Community at the road: Soils are classified as Reeves soils. These soils are associated with the loamy ecological site which typically supports black and blue grama and tobosa grasslands with an even distribution of yucca, mesquite, American tarbush, cholla, and creosote.

Existing Vegetation Community at the road

Well Name: KOALA 9 FED COM

Well Number: 124H

Existing Vegetation Community at the pipeline: Soils are classified as Reeves soils. These soils are associated with the loamy ecological site which typically supports black and blue grama and tobosa grasslands with an even distribution of yucca, mesquite, American tarbush, cholla, and creosote.

Existing Vegetation Community at the pipeline

Existing Vegetation Community at other disturbances: Soils are classified as Reeves soils. These soils are associated with the loamy ecological site which typically supports black and blue grama and tobosa grasslands with an even distribution of yucca, mesquite, American tarbush, cholla, and creosote.

Existing Vegetation Community at other disturbances

Non native seed used? N

Non native seed description:

Seedling transplant description:

Will seedlings be transplanted for this project? N

Seedling transplant description attachment:

Will seed be harvested for use in site reclamation? N

Seed harvest description:

Seed harvest description attachment:

[Seed](#)

[Seed Table](#)

Seed Summary	
Seed Type	Pounds/Acre

Total pounds/Acre:

Seed reclamation

[Operator Contact/Responsible Official](#)

First Name:

Last Name:

Phone:

Email:

Seedbed prep: Initial seedbed preparation will consist of recontouring to the appropriate interim or final reclamation standard. All compacted areas to be seeded will be ripped to a minimum depth of 18 inches with a minimum furrow spacing of 2 feet, followed by recontouring the surface and then evenly spreading the stockpiled topsoil. Prior to seeding, the seedbed will be scarified to a depth of no less than 4-6 inches. If the site is to be broadcast seeded, the surface will be left rough enough to trap seed and snow, control erosion, and increase water infiltration.

Seed BMP: If broadcast seeding is to be used and is delayed, final seedbed preparation will consist of contour cultivating to a depth of 4-6 inches within 24 hours prior to seeding, dozer tracking, or other imprinting in order to break the soil crust and create seed germination micro-sites.

Well Name: KOALA 9 FED COM

Well Number: 124H

Seed method: Seeding will be conducted no more than two weeks following completion of final seedbed preparation. A certified weed-free seed mix designed by the BLM to meet reclamation standards will be used.

Existing invasive species? N

Existing invasive species treatment description:

Existing invasive species treatment

Weed treatment plan description: Weed control for all phases will be through the use of approved pesticides and herbicides according to applicable State, Federal and local laws.

Weed treatment plan

Monitoring plan description: Monitoring of invasive and noxious weeds will be visual and as-needed. If it is determined additional methods are required to monitor invasive and noxious weeds, appropriate BLM authorities will be contacted with a plan of action for approval prior to implementation.

Monitoring plan

Success standards: 100% compliance with applicable regulations.

Pit closure description: There will be no reserve pit as each well will be drilled utilizing a closed loop mud system. The closed loop system will meet the NMOCD requirements 19.15.17.

Pit closure attachment:

Section 11 - Surface

Disturbance type: WELL PAD

Describe:

Surface Owner: BUREAU OF LAND MANAGEMENT,PRIVATE OWNERSHIP

Other surface owner description:

BIA Local Office:

BOR Local Office:

COE Local Office:

DOD Local Office:

NPS Local Office:

State Local Office:

Military Local Office:

USFWS Local Office:

Other Local Office:

USFS Region:

USFS Forest/Grassland:

USFS Ranger District:

Well Name: KOALA 9 FED COM

Well Number: 124H

Surface use plan certification: NO

Surface use plan certification document:

Surface access agreement or bond: AGREEMENT

Surface Access Agreement Need description: land owned by Jimmy & Angela Vasquez, P.O. Box 15, Malaga, NM 88263.

Surface Access Bond BLM or Forest Service:

BLM Surface Access Bond number:

USFS Surface access bond number:

Disturbance type: EXISTING ACCESS ROAD

Describe:

Surface Owner: BUREAU OF LAND MANAGEMENT,PRIVATE OWNERSHIP

Other surface owner description:

BIA Local Office:

BOR Local Office:

COE Local Office:

DOD Local Office:

NPS Local Office:

State Local Office:

Military Local Office:

USFWS Local Office:

Other Local Office:

USFS Region:

USFS Forest/Grassland:

USFS Ranger District:

Well Name: KOALA 9 FED COM

Well Number: 124H

Surface use plan certification: NO

Surface use plan certification document:

Surface access agreement or bond: AGREEMENT

Surface Access Agreement Need description: land owned by Jimmy & Angela Vasquez, P.O. Box 15, Malaga, NM 88263.

Surface Access Bond BLM or Forest Service:

BLM Surface Access Bond number:

USFS Surface access bond number:

Disturbance type: OTHER

Describe: Flowline

Surface Owner: BUREAU OF LAND MANAGEMENT

Other surface owner description:

BIA Local Office:

BOR Local Office:

COE Local Office:

DOD Local Office:

NPS Local Office:

State Local Office:

Military Local Office:

USFWS Local Office:

Other Local Office:

USFS Region:

USFS Forest/Grassland:

USFS Ranger District:

Well Name: KOALA 9 FED COM

Well Number: 124H

Disturbance type: OTHER

Describe: CTB

Surface Owner: BUREAU OF LAND MANAGEMENT

Other surface owner description:

BIA Local Office:

BOR Local Office:

COE Local Office:

DOD Local Office:

NPS Local Office:

State Local Office:

Military Local Office:

USFWS Local Office:

Other Local Office:

USFS Region:

USFS Forest/Grassland:

USFS Ranger District:

Section 12 - Other

Right of Way needed? Y

Use APD as ROW? Y

ROW Type(s): 281001 ROW - ROADS,288100 ROW – O&G Pipeline,289001 ROW- O&G Well Pad

ROW

SUPO Additional Information: Well pad locations have been construction. Surveys of the access roads and well pad locations have been completed by Transglobal, a registered professional land surveyor. Center stake surveys with access roads have been completed on Federal lands with Jeff Robertson, Bureau of Land Management Natural Resource Specialist, in attendance April 6, 2022.

Use a previously conducted onsite? Y

Previous Onsite information: Onsite: April 6, 2022, with Jeff Robertson, Bureau of Land Management NRS.

Other SUPO

Well Name: KOALA 9 FED COM

Well Number: 124H

Koala_9_Fed_Com_Well_List_20251029113018.pdf

Koala_9_Fed_Com_SUPO__NSD__20251030121641.pdf

1 MILE RADIUS MAP

Koala 9 Fed Com

Section 8, Township 20 South, Range 28 East, Eddy County, New Mexico

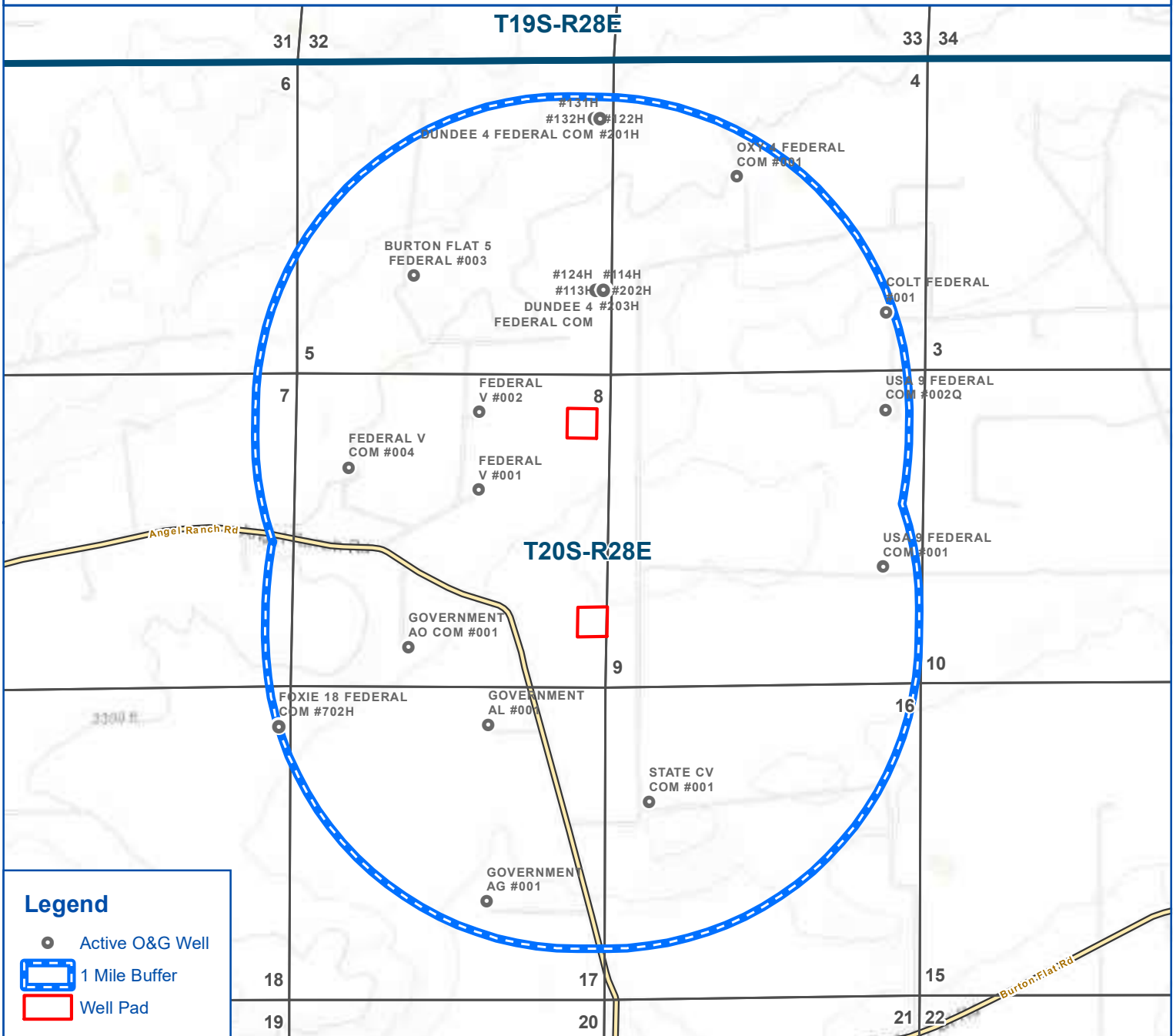

Legend

- Active O&G Well
- 1 Mile Buffer
- Well Pad

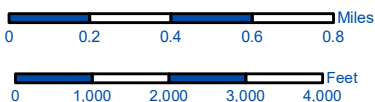

Map Tech: VSD

1" = 2,500'

Date: 10/21/2025

1:30,000

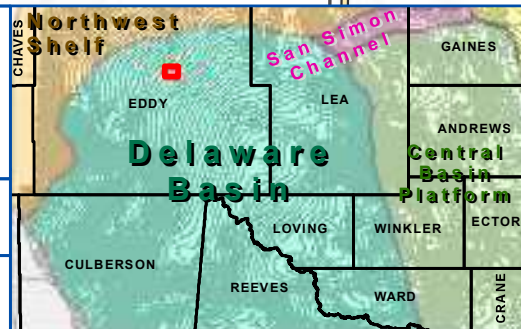

KOALA 9 FED COM

Section 8, Township 20 South,
Range 28 East
Eddy County, New Mexico

OPERATOR:
PERMIAN RESOURCES



201 West Wall St, Suite 325
Midland, TX 79701

Coordinate System:
 NAD 1983 StatePlane New Mexico East FIPS 3001 Feet
 Projection: Transverse Mercator
 Datum: North American 1983
 False Easting: 541,337.5000
 False Northing: 0.0000
 Central Meridian: -104.3333
 Scale Factor: 0.9999
 Latitude Of Origin: 31.0000
 Units: Foot US



SECTION 5
TOWNSHIP 20 SOUTH, RANGE 28 EAST
NEW MEXICO PRINCIPAL MERIDIAN
EDDY COUNTY, NEW MEXICO

DUNDEE 4 FED COM
CTB PAD
150,000 SQUARE FEET
(3.444 ACRES)

SE-SE
(BLM)

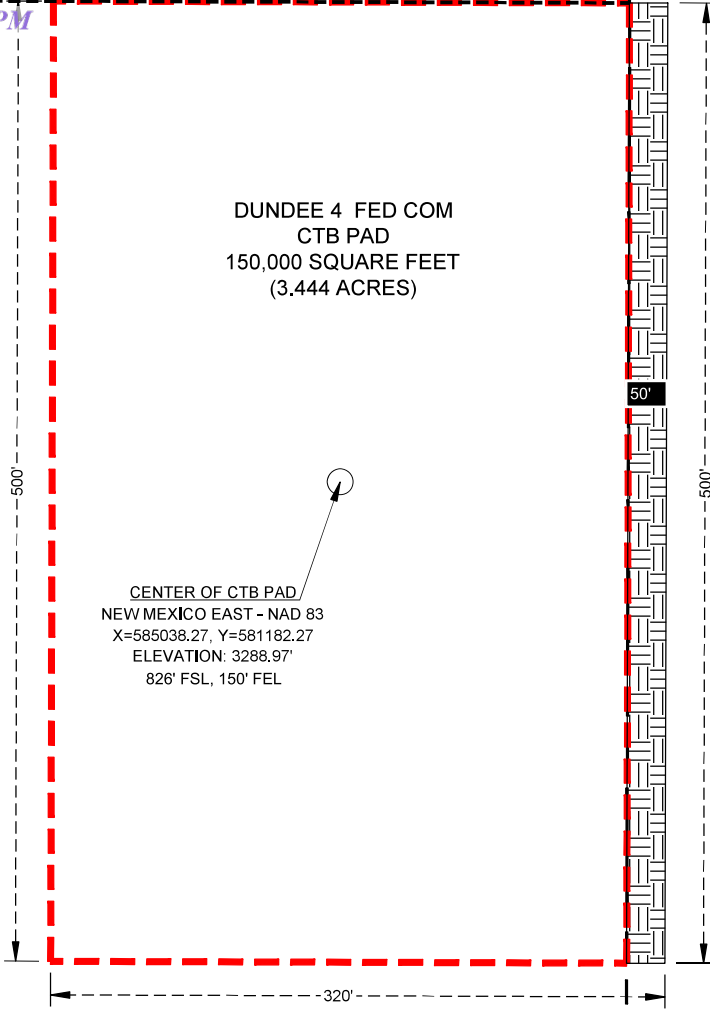

CENTER OF CTB PAD
NEW MEXICO EAST - NAD 83
X=585038.27, Y=581182.27
ELEVATION: 3288.97'
826' FSL, 150' FEL

- LEGEND**
- SECTION LINE
 - PAD SITE
 - TOP SOIL AREA
 - CENTER OF PAD

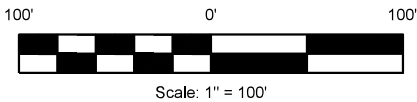

10/23/2025

I, CHARLES JURICA, A NEW MEXICO PROFESSIONAL SURVEYOR, DO HEREBY CERTIFY THAT I CONDUCTED AND AM RESPONSIBLE FOR THIS SURVEY. THAT THIS SURVEY IS TRUE AND CORRECT TO THE BEST OF MY KNOWLEDGE AND BELIEF, AND THAT THIS SURVEY AND PLAT MEET THE MINIMUM STANDARDS FOR SURVEYING IN NEW MEXICO.

Charles Jurica

CHARLES JURICA NEW MEXICO PS #25490 DATE

NOTES:

1. BEARINGS, DISTANCES, AREA AND COORDINATES SHOWN HEREON ARE CORRELATED TO THE NEW MEXICO STATE PLANE COORDINATE SYSTEM OF 1983, EAST ZONE, AS DETERMINED BY GPS OPUS OBSERVATIONS. ALL BEARINGS AND DISTANCES SHOWN ARE GRID.
2. LATITUDE & LONGITUDE ARE NAD 83 DECIMAL GEOGRAPHIC.
3. THIS SURVEY WAS PERFORMED WITHOUT THE BENEFIT OF A TITLE REPORT AND THE REVIEW OF THE ABSTRACT OF TITLE. THERE MAY BE EASEMENTS AND/OR COVENANTS AFFECTING THIS PROPERTY NOT SHOWN HEREON. LOCATION OF ALL IMPROVEMENTS WAS BEYOND COMMISSIONED SCOPE OF THIS PROJECT AND HAS BEEN SPECIFICALLY OMITTED. VESTING DOCUMENTS NOT FURNISHED FOR THIS SURVEY.

PERMIAN
RESOURCES

DUNDEE 4 FED COM
BUREAU OF LAND MANAGEMENT
CTB PAD RECLAMATION PLAT

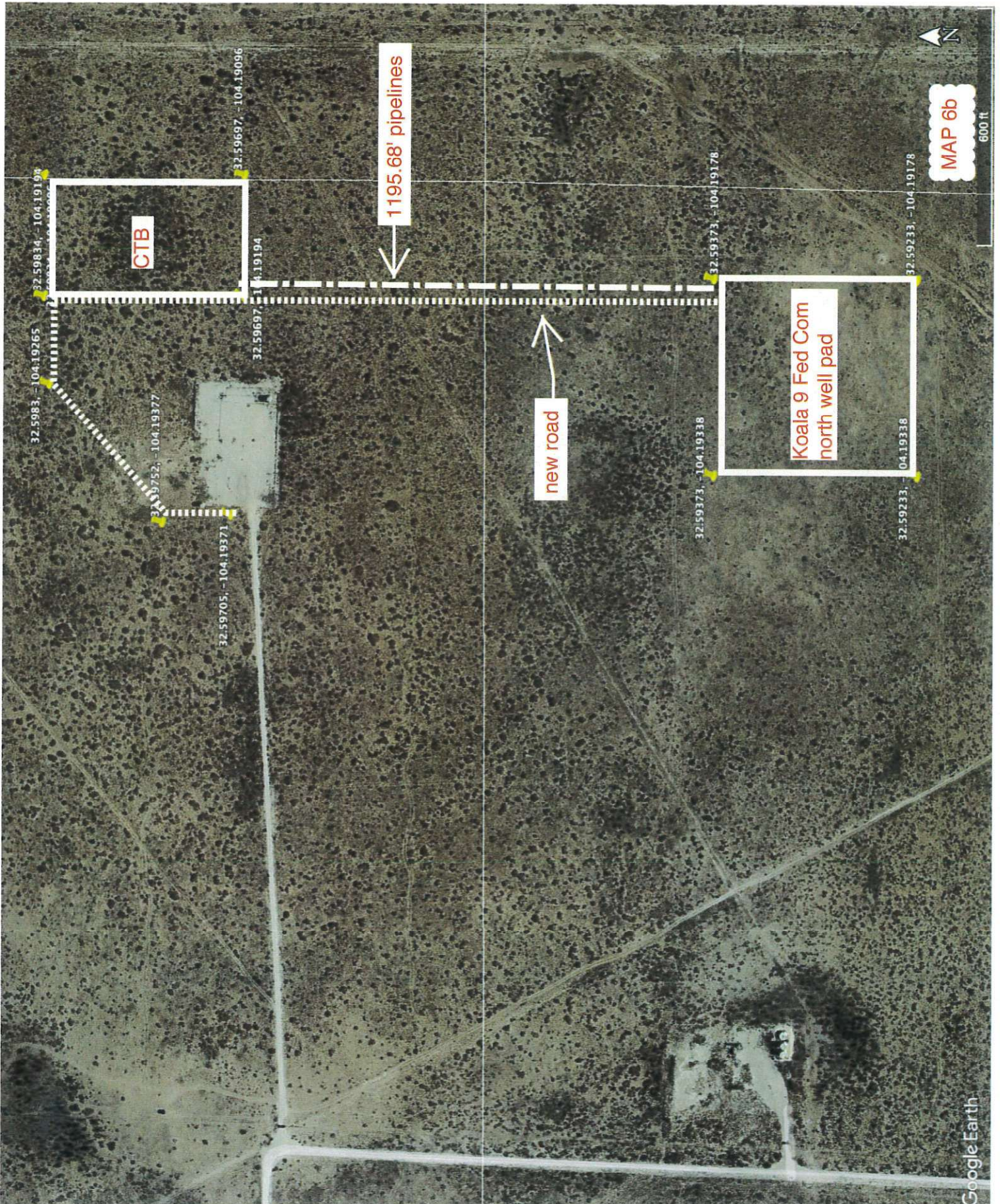

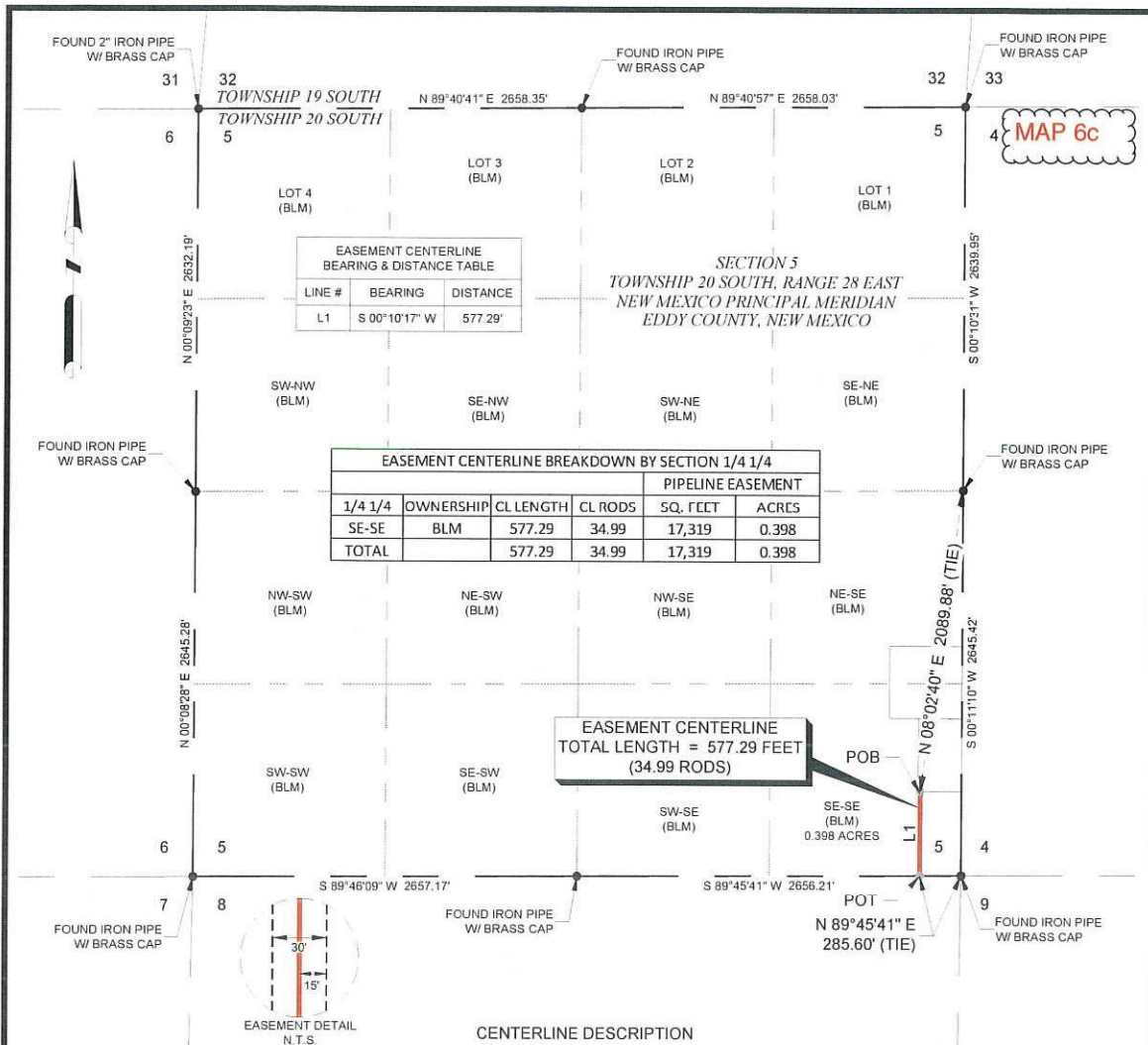

BEING THE CENTERLINE OF A PROPOSED PIPELINE EASEMENT, SITUATED IN SECTION 5, TOWNSHIP 20 SOUTH, RANGE 28 EAST, NEW MEXICO PRINCIPAL MERIDIAN, EDDY COUNTY, NEW MEXICO. SAID CENTERLINE BEING MORE PARTICULARLY DESCRIBED BY METES AND BOUNDS AS FOLLOWS:

BEGINNING AT A POINT, IN SAID SECTION 5, FROM WHICH AN IRON PIPE WITH A BRASS CAP FOUND FOR THE EAST QUARTER CORNER OF SAID SECTION 5 BEARS N 08°02'40" E, A DISTANCE OF 2089.88 FEET (TIE), SAID POINT OF BEGINNING HAVING A NEW MEXICO STATE PLANE COORDINATES OF 1983, EAST ZONE, VALUE OF N:580932.72, E:584901.78 FEET FOR REFERENCE;

THENCE S 00°10'17" W, A DISTANCE OF 577.29 FEET TO THE POINT OF TERMINATION OF SAID CENTERLINE IN THE SOUTH BOUNDARY LINE OF SAID SECTION 5, FROM WHICH AN IRON PIPE WITH A BRASS CAP FOUND FOR THE SOUTHEAST CORNER OF SAID SECTION 5 BEARS N 89°45'41" E, A DISTANCE OF 285.60 FEET (TIE), SAID POINT OF TERMINATION HAVING A NEW MEXICO STATE PLANE COORDINATES OF 1983, EAST ZONE, VALUE OF N:580355.44, E:584900.06 FEET FOR REFERENCE.

SAID CENTERLINE CONTAINING A TOTAL OF 577.29 FEET OR 34.99 RODS IN SAID SECTION 5.

LEGEND

- SECTION LINE
- OHE
- EASEMENT CENTERLINE
- PERMANENT EASEMENT
- EXISTING PIPELINE
- FENCE LINE
- POWER POLE
- FOUND MONUMENT
- CALCULATED CORNER
- BEARING CHANGE

Scale: 1" = 1000'

NOTES

- BEARINGS, DISTANCES, AREA AND COORDINATES SHOWN HEREON ARE CORRELATED TO THE NEW MEXICO STATE PLANE COORDINATE SYSTEM OF 1983, EAST ZONE, AS DETERMINED BY GPS OPUS OBSERVATIONS. ALL BEARINGS AND DISTANCES SHOWN ARE GRID.
- LATITUDE & LONGITUDE ARE NAD 83 DECIMAL GEOGRAPHIC.
- THIS SURVEY WAS PERFORMED WITHOUT THE BENEFIT OF A TITLE REPORT AND THE REVIEW OF THE ABSTRACT OF TITLE. THERE MAY BE EASEMENTS AND/OR COVENANTS EFFECTING THIS PROPERTY NOT SHOWN HEREON. LOCATION OF ALL IMPROVEMENTS WAS BEYOND COMMISSIONED SCOPE OF THIS PROJECT AND HAS BEEN SPECIFICALLY OMITTED. VESTING DOCUMENTS NOT FURNISHED FOR THIS SURVEY.



 I, MARK J. MURRAY, A NEW MEXICO PROFESSIONAL LAND SURVEYOR, DO HEREBY CERTIFY THAT I CONDUCTED AND AM RESPONSIBLE FOR THIS SURVEY THAT THIS SURVEY IS TRUE AND CORRECT TO THE BEST OF MY KNOWLEDGE AND BELIEF, AND THAT THIS SURVEY AND PLAT MEET THE MINIMUM REQUIREMENTS FOR SURVEYING IN NEW MEXICO.

MARK J. MURRAY NEW MEXICO PS #12177 DATE 5/11/2022

#	DATE	BY	DESCRIPTION	CHK
PROJECT NO. 10324				
TBPELS FIRM# 10193740 / 19148 2129 S Great Southwest Parkway Suite 313 Grand Prairie, TX 75051 (817) 529-1180 ~ Fax (817) 529-1181				
 TRANSGLOBAL SERVICES LLC				

KOALA 9 FED COM NORTH PAD
BUREAU OF LAND MANAGEMENT
PROPOSED PIPELINES EASEMENT CENTERLINE
 SITUATED IN SECTION 5
 TOWNSHIP 20 SOUTH, RANGE 28 EAST
 NEW MEXICO PRINCIPAL MERIDIAN
 EDDY COUNTY, NEW MEXICO

DRAWN BY: MJM	DATE: 04/08/22	DWG. NO. 10324 KOALA 9 FED COM FLOWLINE (5-20S-28E)	REV. 0
CHECKED BY: MJM	DATE: 05/10/22		
SCALE: 1"=1000'	PAGE 1 OF 1		

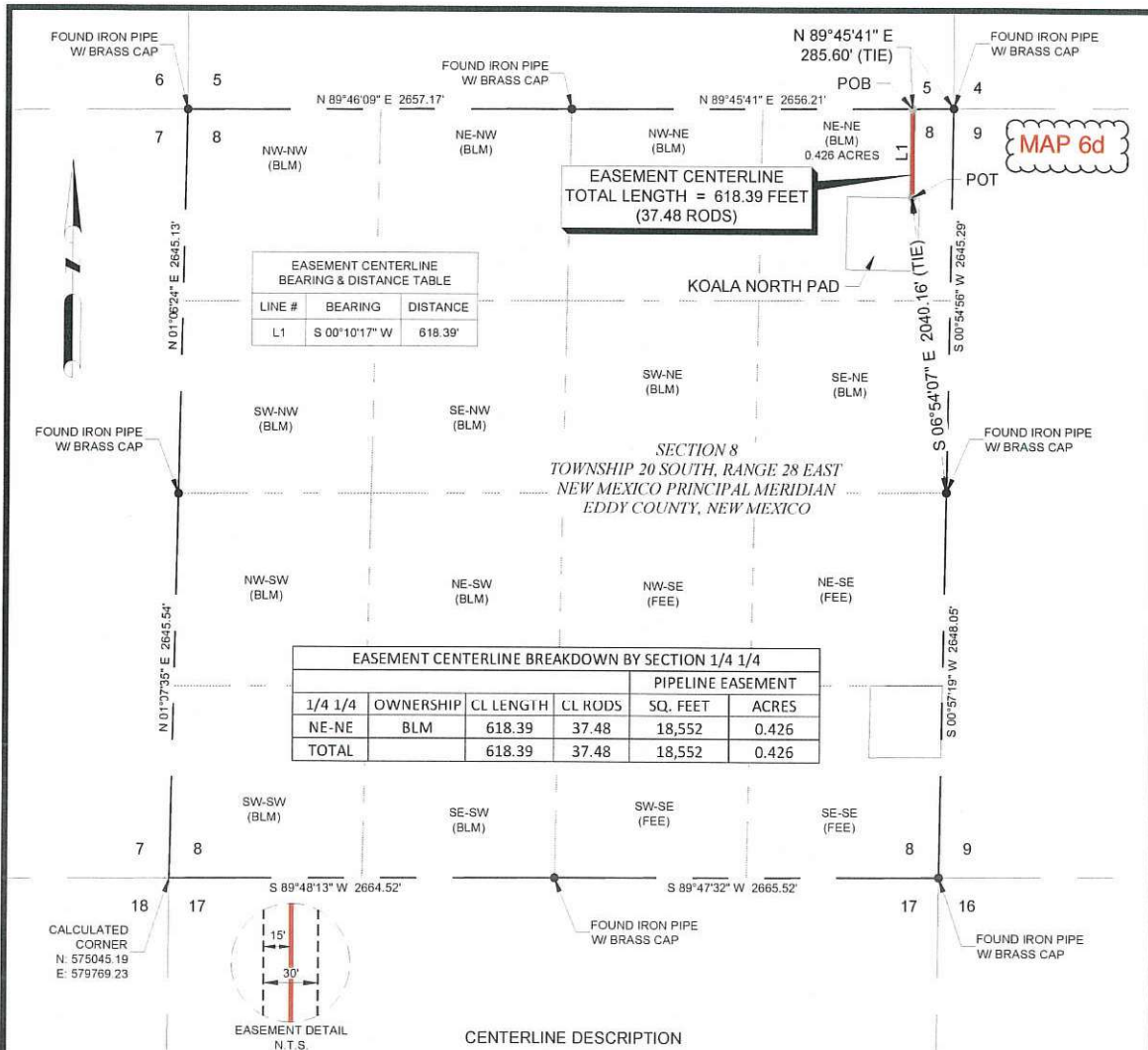

EASEMENT CENTERLINE BEARING & DISTANCE TABLE

LINE #	BEARING	DISTANCE
L1	S 00°10'17" W	618.39'

EASEMENT CENTERLINE BREAKDOWN BY SECTION 1/4 1/4

1/4 1/4	OWNERSHIP	CL LENGTH	CL RODS	SQ. FEET	ACRES
NE-NE	BLM	618.39	37.48	18,552	0.426
TOTAL		618.39	37.48	18,552	0.426

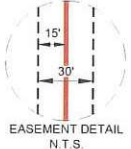

BEING THE CENTERLINE OF A PROPOSED PIPELINE EASEMENT, SITUATED IN SECTION 8, TOWNSHIP 20 SOUTH, RANGE 28 EAST, NEW MEXICO PRINCIPAL MERIDIAN, EDDY COUNTY, NEW MEXICO. SAID CENTERLINE BEING MORE PARTICULARLY DESCRIBED BY METES AND BOUNDS AS FOLLOWS:

BEGINNING AT A POINT, IN THE NORTH BOUNDARY LINE OF SAID SECTION 8, FROM WHICH AN IRON PIPE WITH A BRASS CAP FOUND FOR THE NORTHEAST CORNER OF SAID SECTION 8 BEARS N 89°45'41" E, A DISTANCE OF 285.60 FEET (TIE), SAID POINT OF BEGINNING HAVING A NEW MEXICO STATE PLANE COORDINATES OF 1983, EAST ZONE, VALUE OF N:580025.44, E:584899.07 FEET FOR REFERENCE;

THENCE S 00°10'17" W, A DISTANCE OF 618.39 FEET TO THE POINT OF TERMINATION OF SAID CENTERLINE IN SAID SECTION 8, FROM WHICH AN IRON PIPE WITH A BRASS CAP FOUND FOR THE EAST QUARTER CORNER OF SAID SECTION 8 BEARS S 06°54'07" E, A DISTANCE OF 2040.16 FEET (TIE), SAID POINT OF TERMINATION HAVING A NEW MEXICO STATE PLANE COORDINATES OF 1983, EAST ZONE, VALUE OF N:579737.05, E:584898.21 FEET FOR REFERENCE.

SAID CENTERLINE CONTAINING A TOTAL OF 618.39 FEET OR 37.48 RODS IN SAID SECTION 8.

LEGEND

- SECTION LINE
- OHE OVERHEAD ELECTRIC
- EASEMENT CENTERLINE
- - - PERMANENT EASEMENT
- - - EXISTING PIPELINE
- - - FENCE LINE
- POWER POLE
- FOUND MONUMENT
- CALCULATED CORNER
- BEARING CHANGE

Scale: 1" = 1000'

MARK J. MURRAY
NEW MEXICO
12177

I, MARK J. MURRAY, A NEW MEXICO PROFESSIONAL LAND SURVEYOR, DO HEREBY CERTIFY THAT I CONDUCTED AND AM RESPONSIBLE FOR THIS SURVEY AND THAT THIS SURVEY IS TRUE AND CORRECT TO THE BEST OF MY KNOWLEDGE AND BELIEF AND THAT THIS SURVEY AND PLAT MEET THE MINIMUM STANDARDS FOR SURVEYING IN NEW MEXICO.

5/11/2022
MARK J. MURRAY NEW MEXICO PS #12177 DATE

- NOTES:
- BEARINGS, DISTANCES, AREA AND COORDINATES SHOWN HEREON ARE CORRELATED TO THE NEW MEXICO STATE PLANE COORDINATE SYSTEM OF 1983, EAST ZONE, AS DETERMINED BY GPS OPUS OBSERVATIONS. ALL BEARINGS AND DISTANCES SHOWN ARE GRID.
 - LATITUDE & LONGITUDE ARE NAD 83 DECIMAL GEOGRAPHIC.
 - THIS SURVEY WAS PERFORMED WITHOUT THE BENEFIT OF A TITLE REPORT AND THE REVIEW OF THE ABSTRACT OF TITLE. THERE MAY BE EASEMENTS AND/OR COVENANTS EFFECTING THIS PROPERTY NOT SHOWN HEREON. LOCATION OF ALL IMPROVEMENTS WAS BEYOND COMMISSIONED SCOPE OF THIS PROJECT AND HAS BEEN SPECIFICALLY OMITTED. VESTING DOCUMENTS NOT FURNISHED FOR THIS SURVEY.

#	DATE	BY	DESCRIPTION	CHK
PROJECT NO. 10324				

TBPELS FIRM# 10193740 / 19148
2129 S Great Southwest Parkway Suite 313
Grand Prairie, TX 75051
(817) 529-1180 ~ Fax (817) 529-1181

KOALA 9 FED COM NORTH PAD
BUREAU OF LAND MANAGEMENT
PROPOSED PIPELINES EASEMENT CENTERLINE
SITUATED IN SECTION 8
TOWNSHIP 20 SOUTH, RANGE 28 EAST
NEW MEXICO PRINCIPAL MERIDIAN
EDDY COUNTY, NEW MEXICO

DRAWN BY: MJM	DATE: 04/08/22	DWG. NO. 10324 KOALA 9 FED COM FLOWLINE NORTH PAD (8-20S-28E)	REV. 0
CHECKED BY: MJM	DATE: 05/10/22		
SCALE: 1"=1000'	PAGE 1 OF 1		



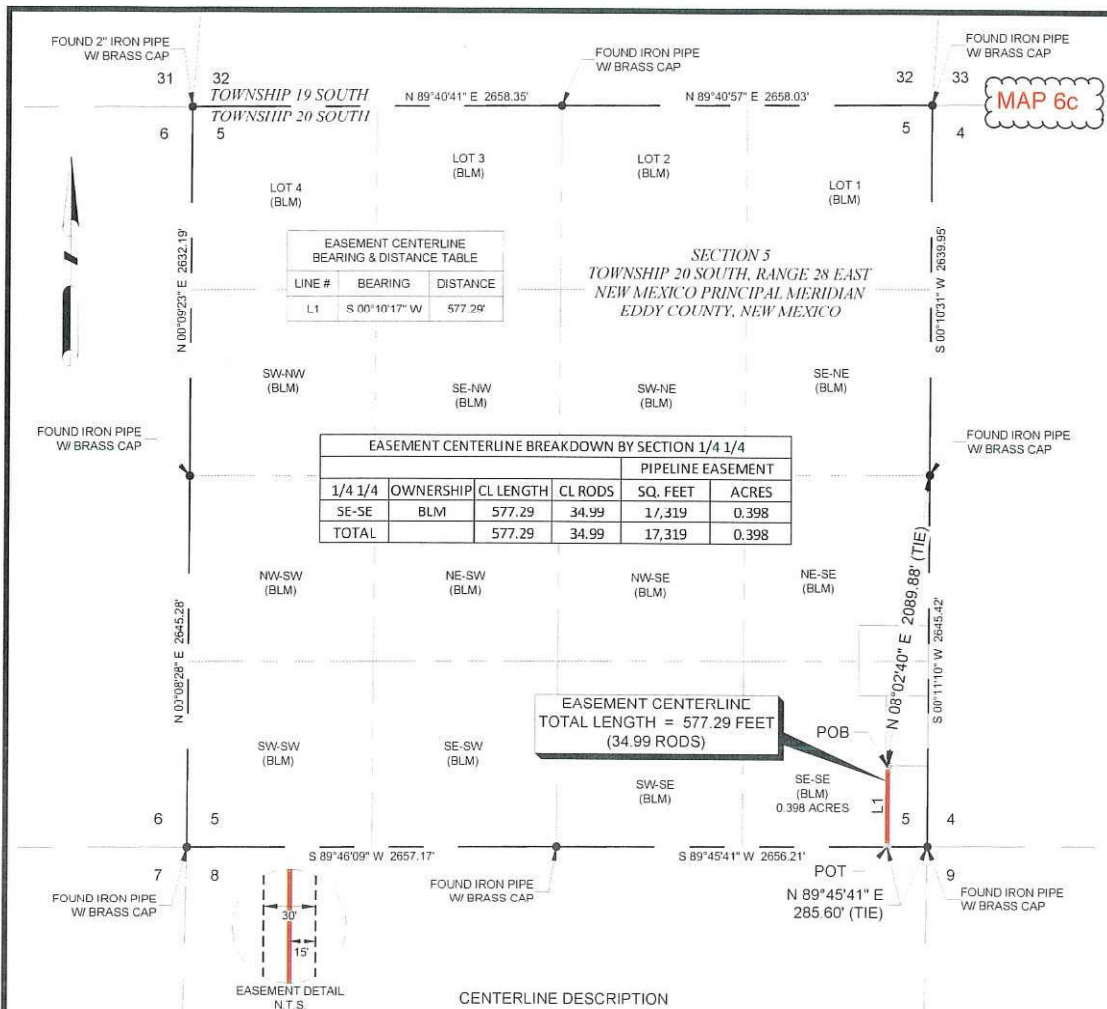

BEING THE CENTERLINE OF A PROPOSED PIPELINE EASEMENT, SITUATED IN SECTION 5, TOWNSHIP 20 SOUTH, RANGE 28 EAST, NEW MEXICO PRINCIPAL MERIDIAN, EDDY COUNTY, NEW MEXICO. SAID CENTERLINE BEING MORE PARTICULARLY DESCRIBED BY METES AND BOUNDS AS FOLLOWS:

BEGINNING AT A POINT, IN SAID SECTION 5, FROM WHICH AN IRON PIPE WITH A BRASS CAP FOUND FOR THE EAST QUARTER CORNER OF SAID SECTION 5 BEARS N 08°02'40" E, A DISTANCE OF 2089.88 FEET (TIE). SAID POINT OF BEGINNING HAVING A NEW MEXICO STATE PLANE COORDINATES OF 1983, EAST ZONE, VALUE OF N:580932.72, E:584901.78 FEET FOR REFERENCE;

THENCE S 00°10'17" W, A DISTANCE OF 577.29 FEET TO THE POINT OF TERMINATION OF SAID CENTERLINE IN THE SOUTH BOUNDARY LINE OF SAID SECTION 5, FROM WHICH AN IRON PIPE WITH A BRASS CAP FOUND FOR THE SOUTHEAST CORNER OF SAID SECTION 5 BEARS N 89°45'41" E, A DISTANCE OF 285.60 FEET (TIE). SAID POINT OF TERMINATION HAVING A NEW MEXICO STATE PLANE COORDINATES OF 1983, EAST ZONE, VALUE OF N:580355.44, E:584900.06 FEET FOR REFERENCE.

SAID CENTERLINE CONTAINING A TOTAL OF 577.29 FEET OR 34.99 RODS IN SAID SECTION 5.

LEGEND

- SECTION LINE
- OHE
- OVERHEAD ELECTRIC
- EASEMENT CENTERLINE
- PERMANENT EASEMENT
- EXISTING PIPELINE
- X FENCE LINE
- POWER POLE
- FOUND MONUMENT
- CALCULATED CORNER
- BEARING CHANGE

Scale: 1" = 1000'

MARK J. MURRAY
NEW MEXICO
12177

I, MARK J. MURRAY, A NEW MEXICO PROFESSIONAL LAND SURVEYOR, DO HEREBY CERTIFY THAT I CONDUCTED AND AM RESPONSIBLE FOR THIS SURVEY, THAT THIS SURVEY IS TRUE AND CORRECT TO THE BEST OF MY KNOWLEDGE AND BELIEF, AND THAT THIS SURVEY AND PLAT MEET THE MINIMUM STANDARDS FOR SURVEYING IN NEW MEXICO.

5/11/2022
MARK J. MURRAY NEW MEXICO PS #12177 DATE

NOTES:

- BEARINGS, DISTANCES, AREA AND COORDINATES SHOWN HEREON ARE CORRELATED TO THE NEW MEXICO STATE PLANE COORDINATE SYSTEM OF 1983, EAST ZONE, AS DETERMINED BY GPS OPUS OBSERVATIONS. ALL BEARINGS AND DISTANCES SHOWN ARE GRID.
- LATITUDE & LONGITUDE ARE NAD 83 DECIMAL GEOGRAPHIC.
- THIS SURVEY WAS PERFORMED WITHOUT THE BENEFIT OF A TITLE REPORT AND THE REVIEW OF THE ABSTRACT OF TITLE. THERE MAY BE EASEMENTS AND/OR COVENANTS AFFECTING THIS PROPERTY NOT SHOWN HEREON. LOCATION OF ALL IMPROVEMENTS WAS BEYOND COMMISSIONED SCOPE OF THIS PROJECT AND HAS BEEN SPECIFICALLY OMITTED. VESTING DOCUMENTS NOT FURNISHED FOR THIS SURVEY.

#	DATE	BY	DESCRIPTION	CHK

PROJECT NO. 10324

KOALA 9 FED COM NORTH PAD
BUREAU OF LAND MANAGEMENT
PROPOSED PIPELINES EASEMENT CENTERLINE
SITUATED IN
SECTION 5
TOWNSHIP 20 SOUTH, RANGE 28 EAST
NEW MEXICO PRINCIPAL MERIDIAN
EDDY COUNTY, NEW MEXICO

DRAWN BY: MJM	DATE: 04/08/22	DWG. NO. 10324 KOALA 9 FED COM FLOWLINE (5-20S-28E)	REV. 0
CHECKED BY: MJM	DATE: 05/10/22		
SCALE: 1"=1000'	PAGE 1 OF 1		

TRANSGLOBAL SERVICES LLC
TBPELS FIRM# 10193740 / 19148
2129 S Great Southwest Parkway Suite 313
Grand Prairie, TX 75051
(817) 529-1180 ~ Fax (817) 529-1181

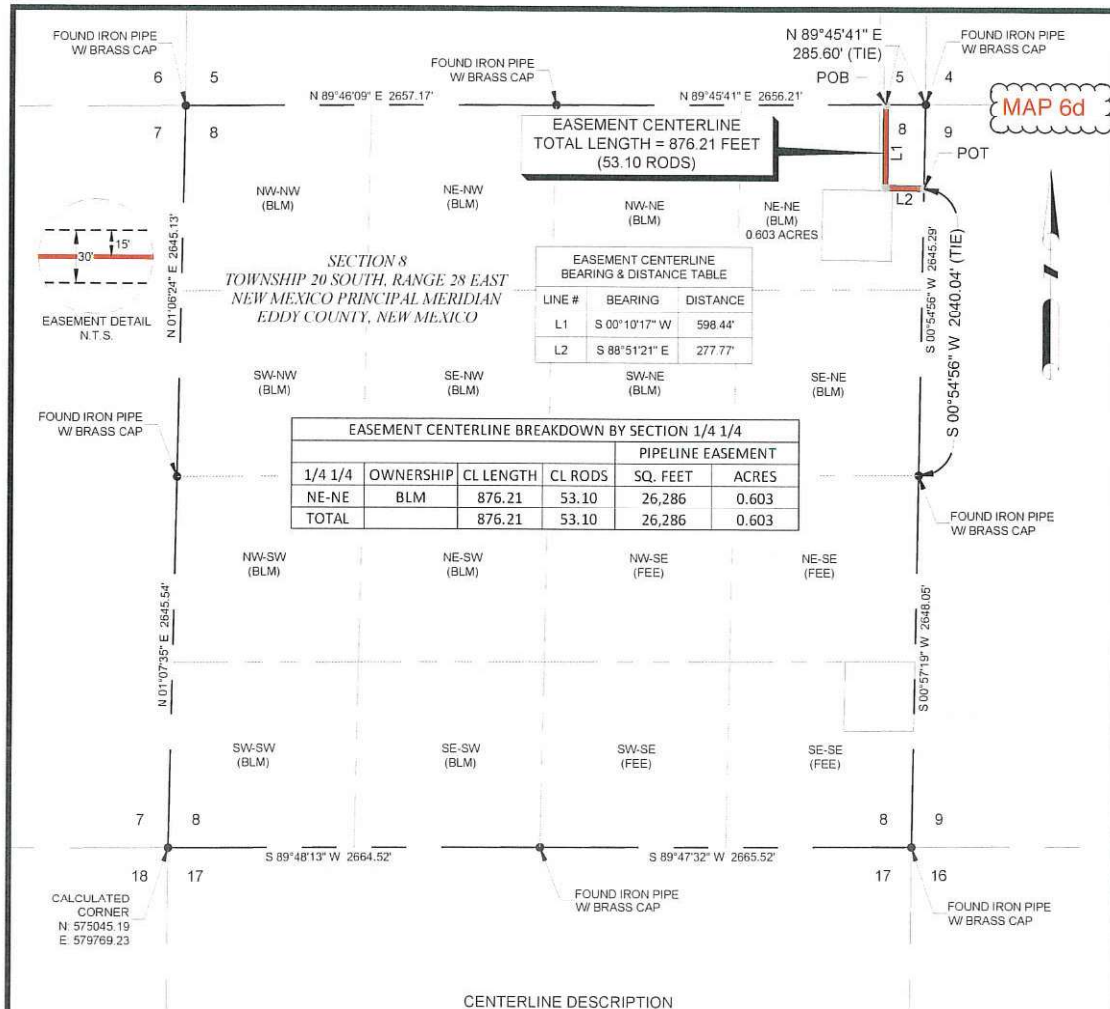

BEING THE CENTERLINE OF A PROPOSED PIPELINE EASEMENT, SITUATED IN SECTION 8, TOWNSHIP 20 SOUTH, RANGE 28 EAST, NEW MEXICO PRINCIPAL MERIDIAN, EDDY COUNTY, NEW MEXICO. SAID CENTERLINE BEING MORE PARTICULARLY DESCRIBED BY METES AND BOUNDS AS FOLLOWS:

BEGINNING AT A POINT, IN THE NORTH BOUNDARY LINE OF SAID SECTION 8, FROM WHICH AN IRON PIPE WITH A BRASS CAP FOUND FOR THE NORTHEAST CORNER OF SAID SECTION 8 BEARS N 89°45'41" E, A DISTANCE OF 285.60 FEET (TIE). SAID POINT OF BEGINNING HAVING A NEW MEXICO STATE PLANE COORDINATES OF 1983, EAST ZONE, VALUE OF N:580355.44, E:584900.06 FEET FOR REFERENCE.

THENCE S 00°10'17" W, A DISTANCE OF 598.44 FEET TO A POINT;

THENCE S 88°51'21" E, A DISTANCE OF 277.77 FEET TO THE POINT OF TERMINATION OF SAID CENTERLINE IN SAID SECTION 8, FROM WHICH AN IRON PIPE WITH A BRASS CAP FOUND FOR THE EAST QUARTER CORNER OF SAID SECTION 8 BEARS S 00°54'56" E, A DISTANCE OF 2040.04 FEET (TIE). SAID POINT OF TERMINATION HAVING A NEW MEXICO STATE PLANE COORDINATES OF 1983, EAST ZONE, VALUE OF N:579751.46, E:585175.98 FEET FOR REFERENCE.

SAID CENTERLINE CONTAINING A TOTAL OF 876.21 FEET OR 53.10 RODS IN SAID SECTION 8

LEGEND

- SECTION LINE
- OHE OVERHEAD ELECTRIC
- EASEMENT CENTERLINE
- PERMANENT EASEMENT
- EXISTING PIPELINE
- FENCE LINE
- X POWER POLE
- FOUND MONUMENT
- CALCULATED CORNER
- BEARING CHANGE

Scale: 1" = 1000'

NOTES

- BEARINGS, DISTANCES, AREA AND COORDINATES SHOWN HEREON ARE CORRELATED TO THE NEW MEXICO STATE PLANE COORDINATE SYSTEM OF 1983, EAST ZONE, AS DETERMINED BY GPS OPUS OBSERVATIONS. ALL BEARINGS AND DISTANCES SHOWN ARE GRID.
- LATITUDE & LONGITUDE ARE NAD 83 DECIMAL GEOGRAPHIC.
- THIS SURVEY WAS PERFORMED WITHOUT THE BENEFIT OF A TITLE REPORT AND THE REVIEW OF THE ABSTRACT OF TITLE. THERE MAY BE EASEMENTS AND/OR COVENANTS AFFECTING THIS PROPERTY NOT SHOWN HEREON. LOCATION OF ALL IMPROVEMENTS WAS BEYOND COMMISSION SCOPE OF THIS PROJECT AND HAS BEEN SPECIFICALLY OMITTED. VESTING DOCUMENTS NOT FURNISHED FOR THIS SURVEY.

#	DATE	BY	DESCRIPTION	CHK
PROJECT NO. 10324				
TBPELS FIRM# 10193740 / 19148 2129 S Great Southwest Parkway Suite 313 Grand Prairie, TX 75051 (817) 529-1180 ~ Fax (817) 529-1181				

I, MARK J. MURRAY, A NEW MEXICO PROFESSIONAL LAND SURVEYOR, DO HEREBY CERTIFY THAT I CONDUCTED AND AM RESPONSIBLE FOR THIS SURVEY, THAT THIS SURVEY IS TRUE AND CORRECT TO THE BEST OF MY KNOWLEDGE AND BELIEF, AND THAT THIS SURVEY AND PLAN MEET THE MINIMUM STANDARDS FOR SURVEYING IN NEW MEXICO.

5/11/2022
MARK J. MURRAY NEW MEXICO PS #12177 DATE

KOALA 9 FED COM SOUTH PAD
BUREAU OF LAND MANAGEMENT
PROPOSED PIPELINES EASEMENT CENTERLINE
SITUATED IN
SECTION 8
TOWNSHIP 20 SOUTH, RANGE 28 EAST
NEW MEXICO PRINCIPAL MERIDIAN
EDDY COUNTY, NEW MEXICO

DRAWN BY: CAS	DATE: 04/14/22	DWG. NO. 10324 KOALA 9 FED COM FLOWLINE SOUTH PAD BLM (8-20S-28E)	REV. 0
CHECKED BY: MJM	DATE: 05/10/22		
SCALE: 1"=1000'	PAGE 1 OF 1		

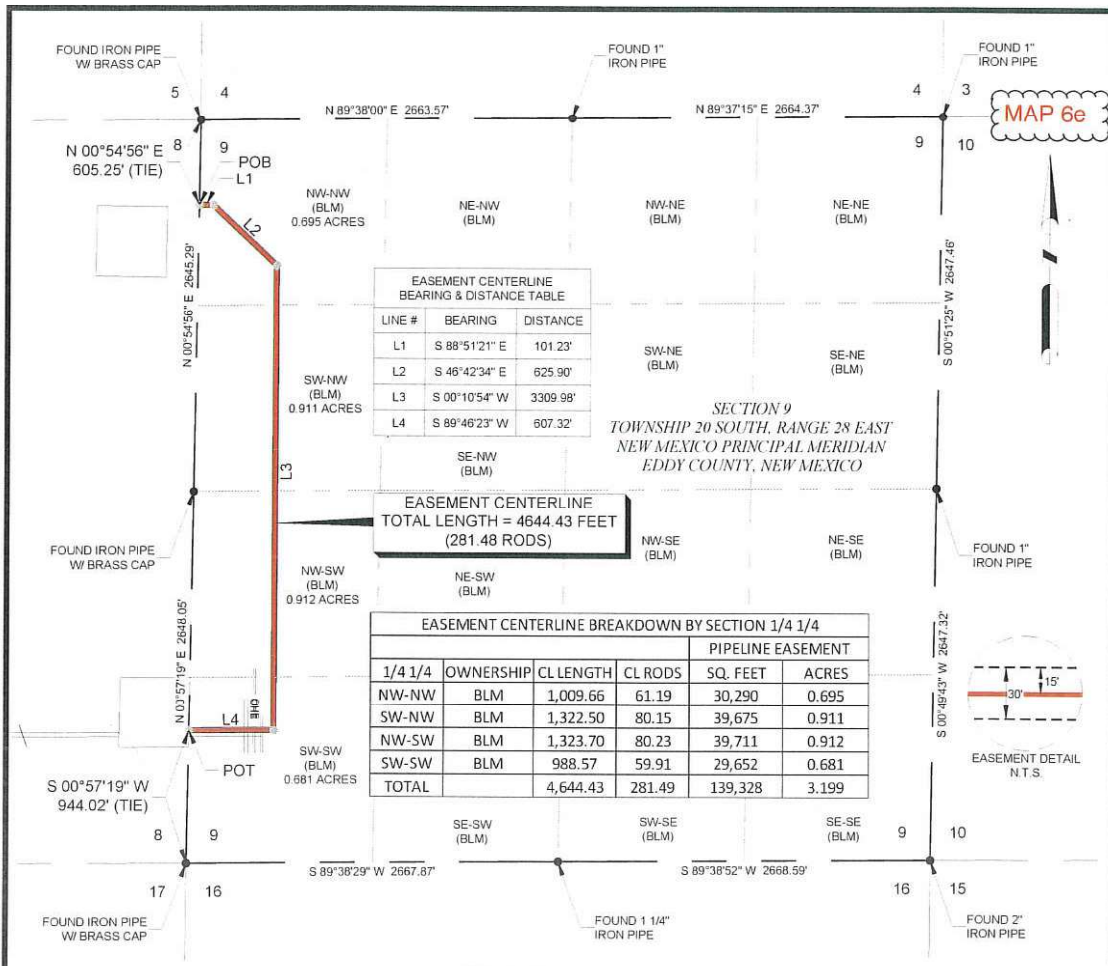

EASEMENT CENTERLINE BEARING & DISTANCE TABLE

LINE #	BEARING	DISTANCE
L1	S 88°51'21" E	101.23'
L2	S 46°42'34" E	625.90'
L3	S 00°10'54" W	3309.98'
L4	S 89°46'23" W	607.32'

EASEMENT CENTERLINE TOTAL LENGTH = 4644.43 FEET (281.48 RODS)

EASEMENT CENTERLINE BREAKDOWN BY SECTION 1/4 1/4

1/4 1/4	OWNERSHIP	CL LENGTH	CL RODS	SQ. FEET	ACRES
NW-NW	BLM	1,009.66	61.19	30,290	0.695
SW-NW	BLM	1,322.50	80.15	39,675	0.911
NW-SW	BLM	1,323.70	80.23	39,711	0.912
SW-SW	BLM	988.57	59.91	29,652	0.681
TOTAL		4,644.43	281.49	139,328	3.199

CENTERLINE DESCRIPTION

BEING THE CENTERLINE OF A PROPOSED PIPELINE EASEMENT, SITUATED IN SECTION 9, TOWNSHIP 20 SOUTH, RANGE 28 EAST, NEW MEXICO PRINCIPAL MERIDIAN, EDDY COUNTY, NEW MEXICO SAID CENTERLINE BEING MORE PARTICULARLY DESCRIBED BY METES AND BOUNDS AS FOLLOWS:

BEGINNING AT A POINT, IN SAID SECTION 9, FROM WHICH AN IRON PIPE WITH A BRASS CAP FOUND FOR THE NORTHWEST CORNER OF SAID SECTION 9 BEARS N 00°54'56" E, A DISTANCE OF 605.25 FEET (TIE), SAID POINT OF BEGINNING HAVING A NEW MEXICO STATE PLANE COORDINATES OF 1983, EAST ZONE, VALUE OF N 579751.46, E 585175.98 FEET FOR REFERENCE,

THENCE S 88°51'21" E, A DISTANCE OF 101.23 FEET TO A POINT,

THENCE S 46°42'34" E, A DISTANCE OF 625.90 FEET TO A POINT,

THENCE S 00°10'54" W, A DISTANCE OF 3309.98 FEET TO A POINT,

THENCE S 89°46'23" W A DISTANCE OF 607.32 FEET TO THE POINT OF TERMINATION OF SAID CENTERLINE IN SAID SECTION 9, FROM WHICH AN IRON PIPE WITH A BRASS CAP FOUND FOR THE SOUTHWEST CORNER OF SAID SECTION 9 BEARS S 00°57'19" W, A DISTANCE OF 944.02 FEET (TIE), SAID POINT OF TERMINATION HAVING A NEW MEXICO STATE PLANE COORDINATES OF 1983, EAST ZONE, VALUE OF N 576007.88, E 585114.97 FEET FOR REFERENCE.

SAID CENTERLINE CONTAINING A TOTAL OF 4644.43 FEET OR 281.48 RODS IN SAID SECTION 9.

- LEGEND**
- SECTION LINE
 - OHE
 - EASEMENT CENTERLINE
 - PERMANENT EASEMENT
 - EXISTING PIPELINE
 - X- FENCE LINE
 - POWER POLE
 - FOUND MONUMENT
 - CALCULATED CORNER
 - ⊕ BEARING CHANGE



I HEREBY STATE THAT THIS SURVEY WAS PERFORMED UNDER MY DIRECT SUPERVISION.

Charles Jurica
 CHARLES JURICA NEW MEXICO PS #25490 DATE

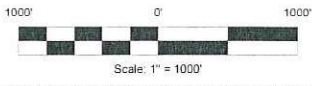

- NOTES**
- BEARINGS, DISTANCES, AREA AND COORDINATES SHOWN HEREON ARE CORRELATED TO THE NEW MEXICO STATE PLANE COORDINATE SYSTEM OF 1983, EAST ZONE, AS DETERMINED BY GPS OPUS OBSERVATIONS. ALL BEARINGS AND DISTANCES SHOWN ARE GRID.
 - LATITUDE & LONGITUDE ARE NAD 83 DECIMAL GEOGRAPHIC.
 - THIS SURVEY WAS PERFORMED WITHOUT THE BENEFIT OF A TITLE REPORT AND THE REVIEW OF THE ABSTRACT OF TITLE. THERE MAY BE EASEMENTS AND/OR COVENANTS AFFECTING THIS PROPERTY NOT SHOWN HEREON. LOCATION OF ALL IMPROVEMENTS WAS BEYOND COMMISSION SCOPE OF THIS PROJECT AND HAS BEEN SPECIFICALLY OMITTED. VESTING DOCUMENTS NOT FURNISHED FOR THIS SURVEY.

#	DATE	BY	DESCRIPTION	CHK
1	05/25/22	BAB	UPDATED ROUTE	CJ

PROJECT NO. 10324

TBPELS FIRM# 10193740
 2129 S Great Southwest Parkway Suite 313
 Grand Prairie, TX 75051
 (817) 529-1180 ~ Fax (817) 529-1181

KOALA 9 FED COM SOUTH PAD
 BUREAU OF LAND MANAGEMENT
 PROPOSED PIPELINES EASEMENT CENTERLINE
 SITUATED IN
 SECTION 9
 TOWNSHIP 20 SOUTH, RANGE 28 EAST
 NEW MEXICO PRINCIPAL MERIDIAN
 EDDY COUNTY, NEW MEXICO

DRAWN BY: CAS	DATE: 04/15/22	DWG. NO. 10324 KOALA 9 FED COM FLOWLINE SOUTH PAD BLM (9-20S-28E)_REV1	REV. 1
CHECKED BY: MJM	DATE: 05/10/22		
SCALE: 1"=1000'	PAGE 1 OF 1		

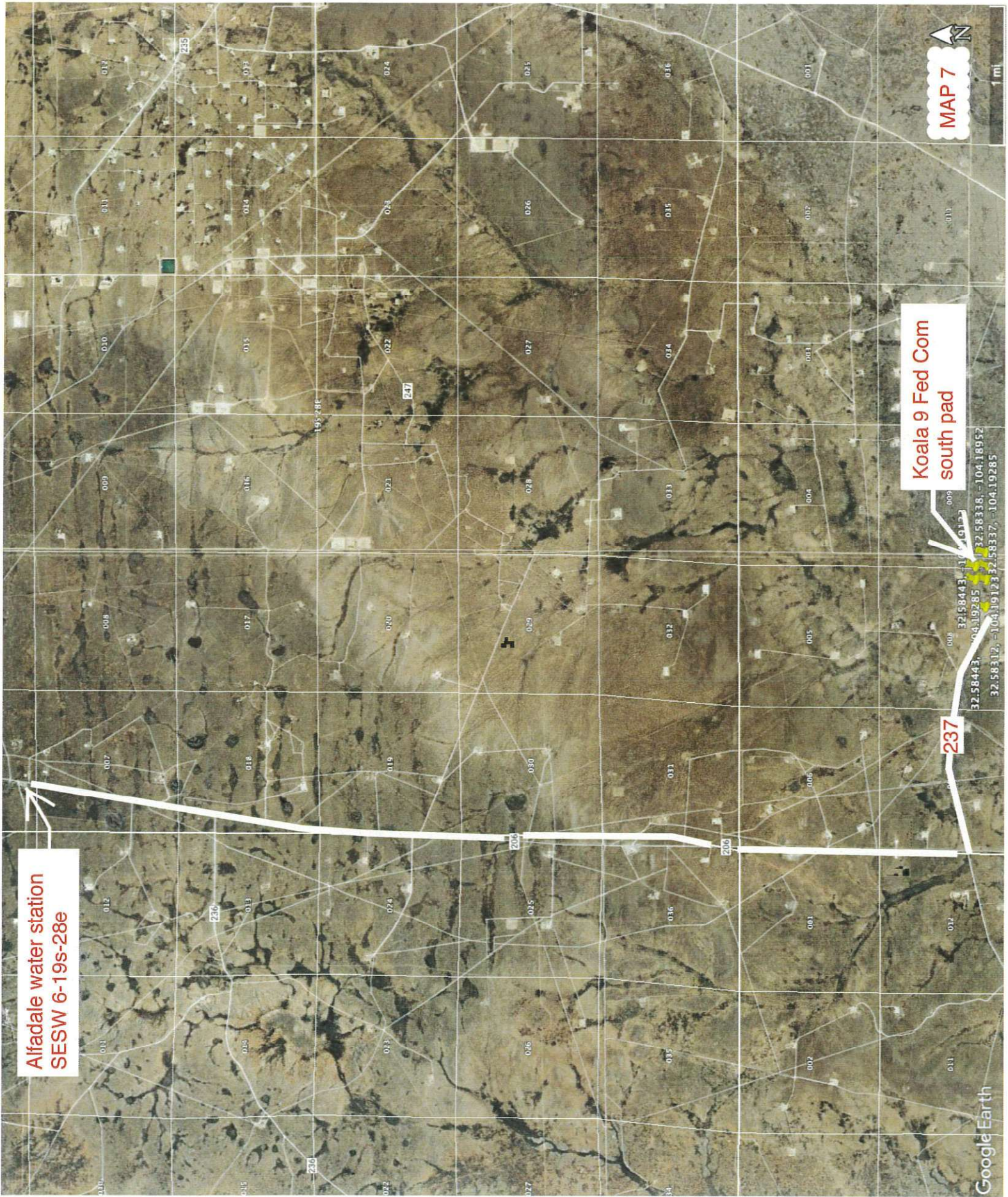

**Alfadale water station
SESW 6-19s-28e**

**Koala 9 Fed Com
south pad**

MAP 7

32.58443, -104.19285
32.58338, -104.18952
32.58337, -104.19285

Google Earth

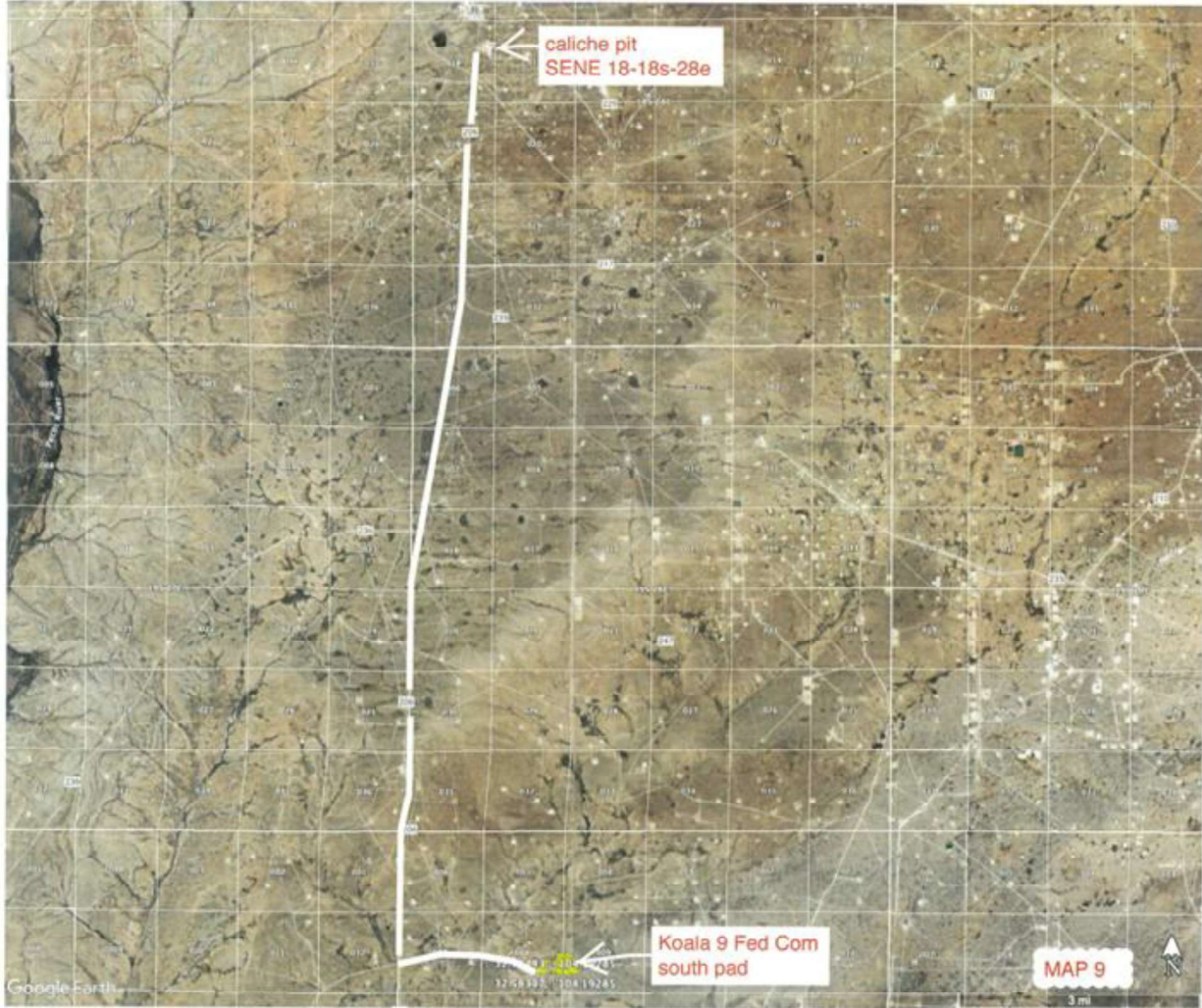

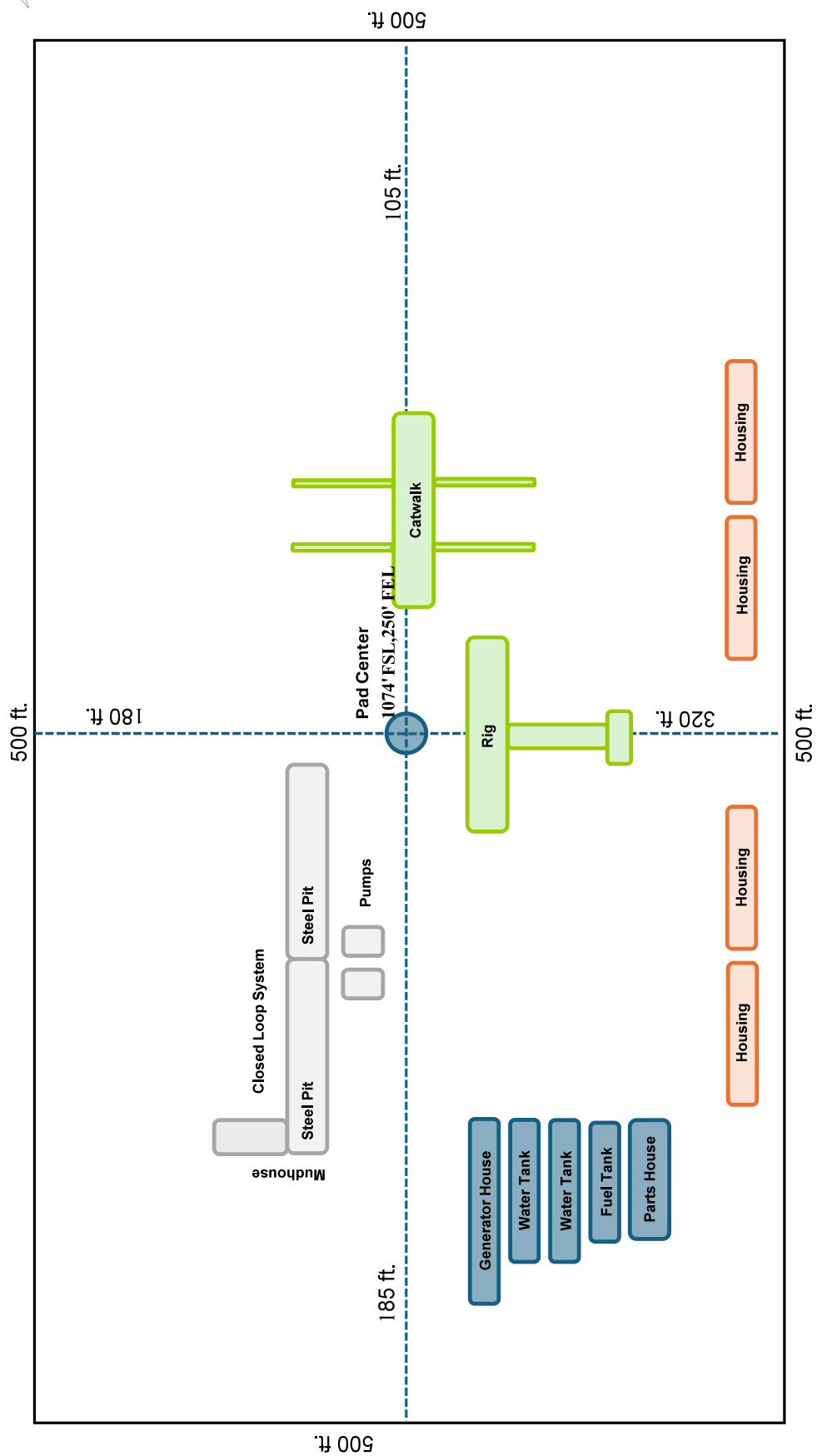

Koala South Pad Rig Layout

THENCE N 89°46'23" E, A DISTANCE OF 500.11 FEET TO A POINT IN THE EAST BOUNDARY LINE OF SAID SECTION 8, FROM WHICH AN IRON PIPE WITH BRASS CAP FOUND FOR THE EAST QUARTER CORNER OF SAID SECTION 8 BEARS N 00°57'19" E, A DISTANCE OF 1323.95 FEET (TIE);
THENCE S 00°57'19" W, A DISTANCE OF 500.11 FEET TO A POINT;
THENCE S 89°46'23" W, A DISTANCE OF 500.11 FEET TO A POINT;
THENCE N 00°57'19" E, A DISTANCE OF 500.11 FEET TO THE POINT OF BEGINNING.

SAID SURFACE SITE CONTAINING A TOTAL OF 250,053 SQUARE FEET OR 5.740 ACRES IN SAID SECTION 8.

NOTES:

- 1. BEARINGS, DISTANCES, AREA AND COORDINATES SHOWN HEREON ARE CORRELATED TO THE NEW MEXICO STATE PLANE COORDINATE SYSTEM OF 1983, EAST ZONE, AS DETERMINED BY GPS OPUS OBSERVATIONS. ALL BEARINGS AND DISTANCES SHOWN ARE GRID.
- 2. LATITUDE & LONGITUDE ARE NAD 83 DECIMAL GEOGRAPHIC.
- 3. THIS SURVEY WAS PERFORMED WITHOUT THE BENEFIT OF A TITLE REPORT AND THE REVIEW OF THE ABSTRACT OF TITLE. THERE MAY BE EASEMENTS AND/OR COVENANTS AFFECTING THIS PROPERTY NOT SHOWN HEREON. LOCATION OF ALL IMPROVEMENTS WAS BEYOND COMMISSIONED SCOPE OF THIS PROJECT AND HAS BEEN SPECIFICALLY OMITTED. VESTING DOCUMENTS NOT FURNISHED FOR THIS SURVEY.



KOALA 9 FED COM SOUTH WELL PAD

PROPOSED WELL PAD

2	10/17/25	SB	CLIENT UPDATE	CJ
---	----------	----	---------------	----

KOALA 9 FED COM 201H
NEW MEXICO EAST - NAD 83
X=584750.65, Y=579559.08
ELEVATION: 3285.05'

KOALA 9 FED COM 202H
NEW MEXICO EAST - NAD 83
X=584630.67, Y=579561.58
ELEVATION: 3285.22'

KOALA 9 FED COM 121H
NEW MEXICO EAST - NAD 83
X=584750.65, Y=579559.08
ELEVATION: 3284.73'

KOALA 9 FED COM 122H
NEW MEXICO EAST - NAD 83
X=584780.65, Y=579559.08
ELEVATION: 3284.67'

KOALA 9 FED COM 111H
NEW MEXICO EAST - NAD 83
X=584810.64, Y=579558.58
ELEVATION: 3284.63'

KOALA 9 FED COM 112H
NEW MEXICO EAST - NAD 83
X=584840.64, Y=579558.08
ELEVATION: 3284.58'

KOALA 9 FED COM
NORTH PAD
250,000 SQUARE FEET
(5.739 ACRES)

INTERIM
RECLAMATION
SEED IN PLACE

INTERIM
RECLAMATION AREA
75,000 SQUARE FEET
(1.722 ACRES)

TOPSOIL AREA
10,000 SQUARE FEET
(0.2296 ACRES)

SECTION 8
TOWNSHIP 20 SOUTH, RANGE 28 EAST
NEW MEXICO PRINCIPAL MERIDIAN
EDDY COUNTY, NEW MEXICO

NE-NE
(BLM)

NE-SE
(BLM)

- LEGEND**
- SECTION LINE
 - PAD SITE
 - ////// INTERM RECLAMATION AREA
 - ▤ TOP SOIL AREA
 - DRILLED SURFACE HOLE LOCATION
 - PERMITTED SURFACE HOLE LOCATION
 - TBD SURFACE HOLE LOCATION
 - ☀ PROPOSED SURFACE LOCATION

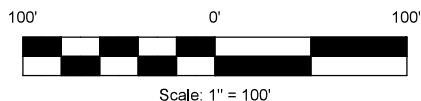

NOTES:

- BEARINGS, DISTANCES, AREA AND COORDINATES SHOWN HEREON ARE CORRELATED TO THE NEW MEXICO STATE PLANE COORDINATE SYSTEM OF 1983, EAST ZONE, AS DETERMINED BY GPS OPUS OBSERVATIONS. ALL BEARINGS AND DISTANCES SHOWN ARE GRID.
- LATITUDE & LONGITUDE ARE NAD 83 DECIMAL GEOGRAPHIC.
- THIS SURVEY WAS PERFORMED WITHOUT THE BENEFIT OF A TITLE REPORT AND THE REVIEW OF THE ABSTRACT OF TITLE. THERE MAY BE EASEMENTS AND/OR COVENANTS AFFECTING THIS PROPERTY NOT SHOWN HEREON. LOCATION OF ALL IMPROVEMENTS WAS BEYOND COMMISSIONED SCOPE OF THIS PROJECT AND HAS BEEN SPECIFICALLY OMITTED. VESTING DOCUMENTS NOT FURNISHED FOR THIS SURVEY.



10/23/2025

I, CHARLES JURICA, A NEW MEXICO PROFESSIONAL LAND SURVEYOR, DO HEREBY CERTIFY THAT I CONDUCTED AND AM RESPONSIBLE FOR THIS SURVEY, THAT THIS SURVEY IS TRUE AND CORRECT TO THE BEST OF MY KNOWLEDGE AND BELIEF, AND THAT THIS SURVEY AND PLAT MEET THE MINIMUM STANDARDS FOR SURVEYING IN NEW MEXICO.

Charles Jurica

CHARLES JURICA NEW MEXICO PS #25490 DATE

PERMIAN
RESOURCES

KOALA 9 FED COM SOUTH WELL PAD

RECLAMATION PLAT

SECTION 8
TOWNSHIP 20 SOUTH, RANGE 28 EAST
NEW MEXICO PRINCIPAL MERIDIAN
EDDY COUNTY, NEW MEXICO

KOALA 9 FED COM
SOUTH PAD
250,053 SQUARE FEET
(5.740 ACRES)

INTERIM
RECLAMATION
SEED IN PLACE

INTERIM
RECLAMATION AREA
42,509 SQUARE FEET
(0.9759 ACRES)

TOPSOIL AREA
9,998 SQUARE FEET
(0.2295 ACRES)

EXISTING
SURFACE POLY
WATERLINE

KOALA 9 FED COM 203H
NEW MEXICO EAST - NAD 83
X=584833.29, Y=576206.86
ELEVATION: 3273.97'
KOALA 9 FED COM 204H
NEW MEXICO EAST - NAD 83
X=584803.28, Y=576206.74
ELEVATION: 3274.36'

KOALA 9 FED COM 123H
NEW MEXICO EAST - NAD 83
X=584923.26, Y=576207.12
ELEVATION: 3273.70'

KOALA 9 FED COM 124H
NEW MEXICO EAST - NAD 83
X=584953.27, Y=576207.24
ELEVATION: 3274.09'

KOALA 9 FED COM 113H
NEW MEXICO EAST - NAD 83
X=584983.28, Y=576207.36
ELEVATION: 3274.23'

KOALA 9 FED COM 114H
NEW MEXICO EAST - NAD 83
X=585013.28, Y=576207.48
ELEVATION: 3274.06'

- LEGEND**
- SECTION LINE
 - PAD SITE
 - //// INTERIM RECLAMATION AREA
 - ▤ TOP SOIL AREA
 - DRILLED SURFACE HOLE LOCATION
 - PERMITTED SURFACE HOLE LOCATION
 - TBD SURFACE HOLE LOCATION
 - ☀ PROPOSED SURFACE LOCATION



10/23/2025

I, CHARLES JURICA, A NEW MEXICO PROFESSIONAL LAND SURVEYOR, DO HEREBY CERTIFY THAT I CONDUCTED AND AM RESPONSIBLE FOR THIS SURVEY, THAT THIS SURVEY IS TRUE AND CORRECT TO THE BEST OF MY KNOWLEDGE AND BELIEF, AND THAT THIS SURVEY AND PLAT MEET THE MINIMUM STANDARDS FOR SURVEYING IN NEW MEXICO.

Charles Jurica

CHARLES JURICA NEW MEXICO PS #25490 DATE

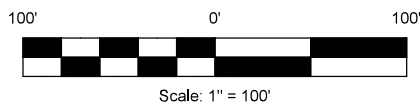

NOTES:

- BEARINGS, DISTANCES, AREA AND COORDINATES SHOWN HEREON ARE CORRELATED TO THE NEW MEXICO STATE PLANE COORDINATE SYSTEM OF 1983, EAST ZONE, AS DETERMINED BY GPS OPUS OBSERVATIONS. ALL BEARINGS AND DISTANCES SHOWN ARE GRID.
- LATITUDE & LONGITUDE ARE NAD 83 DECIMAL GEOGRAPHIC.
- THIS SURVEY WAS PERFORMED WITHOUT THE BENEFIT OF A TITLE REPORT AND THE REVIEW OF THE ABSTRACT OF TITLE. THERE MAY BE EASEMENTS AND/OR COVENANTS AFFECTING THIS PROPERTY NOT SHOWN HEREON. LOCATION OF ALL IMPROVEMENTS WAS BEYOND COMMISSIONED SCOPE OF THIS PROJECT AND HAS BEEN SPECIFICALLY OMITTED. VESTING DOCUMENTS NOT FURNISHED FOR THIS SURVEY.

PERMIAN
RESOURCES

KOALA 9 FED COM SOUTH WELL PAD

RECLAMATION PLAT

Koala 9 Fed Com 111H: Koala North Pad

Surface Hole Location: 362' FEL and 796' FNL, Section 8, T. 20 S., R. 28 E.

Bottom Hole Location: 10' FEL and 990' FNL, Section 10, T. 20 S., R. 28 E.

Koala 9 Fed Com 121H: Koala North Pad

Surface Hole Location: 422' FEL and 795' FNL, Section 8, T. 20 S., R. 28 E.

Bottom Hole Location: 10' FEL and 990' FNL, Section 10, T. 20 S., R. 28 E.

Koala 9 Fed Com 131H: Koala North Pad

Surface Hole Location: 482' FEL and 794' FNL, Section 8, T. 20 S., R. 28 E.

Bottom Hole Location: 10' FEL and 990' FNL, Section 10, T. 20 S., R. 28 E.

Koala 9 Fed Com 112H: Koala North Pad

Surface Hole Location: 332' FEL and 797' FNL, Section 8, T. 20 S., R. 28 E.

Bottom Hole Location: 10' FEL and 2310' FNL, Section 10, T. 20 S., R. 28 E.

Koala 9 Fed Com 123H: Koala South Pad

Surface Hole Location: 195' FEL and 1144' FSL, Section 8, T. 20 S., R. 28 E.

Bottom Hole Location: 10' FEL and 1650' FSL, Section 10, T. 20 S., R. 28 E.

Koala 9 Fed Com 113H: Koala South Pad

Surface Hole Location: 135' FEL and 1144' FSL, Section 8, T. 20 S., R. 28 E.

Bottom Hole Location: 10' FEL and 1650' FSL, Section 10, T. 20 S., R. 28 E.

Koala 9 Fed Com 114H: Koala South Pad

Surface Hole Location: 105' FEL and 1144' FSL, Section 8, T. 20 S., R. 28 E.

Bottom Hole Location: 10' FEL and 330' FSL, Section 10, T. 20 S., R. 28 E.

Koala 9 Fed Com 124H: Koala South Pad

Surface Hole Location: 165' FEL and 1144' FSL, Section 8, T. 20 S., R. 28 E.

Bottom Hole Location: 10' FEL and 330' FSL, Section 10, T. 20 S., R. 28 E.

Well Site Locations

The results of the Koala 9 Fed Com Development Program will develop economic quantities of oil and gas in the Koala 9 Fed Com area with multiple primary formations targeted. Well locations are determined based on cross-section variations and details. Locations will be selected to minimize the likelihood of encountering faults and/or drilling hazards while still targeting suitably productive zones.

If drilling results in an unproductive well, the well will be plugged and abandoned as soon as practical after the conclusion of production testing. Productive wells may be shut-in temporarily for BLM authorization for production activities and facilities.

Surface Use Plan

1. Existing Roads

- A. From the intersection of CR 206 (Illinois Camp Rd and George Shoup Relief Route, proceed north on CR 206 for approximately 8.1 miles. Turn right on Angel Ranch Rd and continue east 1.83 miles, turn left on access road and continue east 0.2 miles to destination. Transportation maps identifying existing roads that will be used to access the project area are included from Transglobal. Marked as, 'Topographical and Access Road Map'.
- B. Transportation Plan identifying existing roads that will be used to access the project area is included from Transglobal marked as, 'Topographical and Access Road Map'. All equipment and vehicles will be confined to the routes shown on the 'Topographical and Access Map' as provided by Transglobal. Maintenance of the access roads will continue until abandonment and reclamation of the well pads is completed.

2. New or Upgraded Access Roads

- A. **New Roads.** We are not applying for new roads for this project. There is no new surface disturbance. We will be using the access roads previously approved for the Koala 9 Fed Com lease area under EA: DOI-BLM-NM-P020-2022-1018-EA.
- B. **Well Pads.** The well pad for this development is already built. No new surface disturbance requested. The access road diagram shows the location of the roads that is constructed and used to access the well pad. We will be using the approved well pad for the Koala 9 Fed Com lease area under EA: DOI-BLM-NM-P020-2022-1018-EA.
- C. **Anticipated Traffic.** After well completion, travel to each well site will include one lease operator truck and two oil trucks per day until the Central Tank Batteries are completed. Upon completion of the Central Tank Batteries, one lease operator truck will continue to travel to each well site to monitor the working order of the wells and to check well equipment for proper operation. Two oil trucks will continue to travel to the Central Tank Batteries only for oil hauling. Additional traffic will include one maintenance truck periodically throughout the year for pad upkeep and weed removal. Well service trips will include only the traffic necessary to work on the wells or provide chemical treatments periodically and as needed throughout the year.
- D. **Routing.** All equipment and vehicles will be confined to the travel routes laid out in the Topographical and Access Map provided by Transglobal, unless otherwise approved by the BLM and applied for by Permian Resources.
- E. **Road Dimensions.** The maximum width of the driving surface of new roads will be 14 feet. The roads will be crowned and ditched with a 2% slope from the tip of the crown to the edge of the driving surface. The ditches will be 1 foot deep with 3:1 slopes. The driving surface will be made of 6" rolled and compacted caliche.

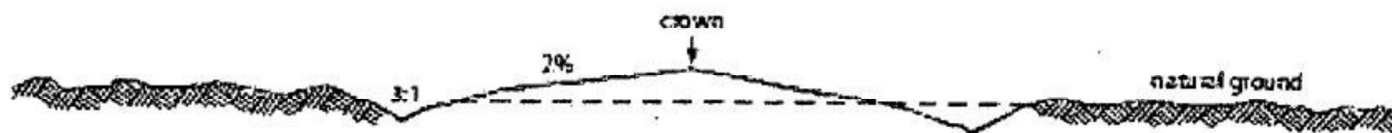

Level Ground Section

- F. **Surface Material.** Surface material will be native caliche. The average grade of all roads will be approximately 3%.
- G. **Fence Cuts:** No.
- H. **Fences:** No.
- I. **Cattle Guards:** No.
- J. **Turnouts:** No.
- K. **Culverts:** No.

- L. **Cuts and Fills:** Not significant.
- M. **Topsoil.** Approximately 6 inches of topsoil (root zone) will be stripped from the proposed access road prior to any further construction activity. The topsoil that was stripped will be spread along the edge of the road and within the ditch. The topsoil will be seeded with the proper seed mix designated by the BLM.
- N. **Maintenance.** The access road will be constructed and maintained as necessary to prevent soil erosion and accommodate all-weather traffic. The road will be crowned and ditched with water turnouts installed as necessary to provide for proper drainage along with access road route.
- O. **Drainage.** The access road and associated drainage structures will be constructed and maintained in accordance with road guidelines contained in the joint BLM/USFS publication: Surface Operating Standards for Oil and Gas Exploration and Development, The Gold Book, Fourth Edition and/or BLM Manual Section 9113 concerning road construction standards on projects subject to federal jurisdiction.

3. Location of Existing Wells

- A. See attached 1-Mile Radius Well map.

4. Ancillary Facilities

- A. **Ancillary Facilities.** No off-pad ancillary facilities are planned during the exploration phase including, but not limited to: campsites, airstrips or staging areas.

5. Location of Proposed Production Facilities

- A. **Production Facilities.** CTB was constructed and all production from the Koala wells will go to the Dundee 4 Fed Com CTB located in the SESE of Section 5-T20S-R28E, NMPM, Eddy County, New Mexico. Centerpoint: 826' FSL, 150' FEL. Plat of the CTB is attached, no new surface disturbance is requested. We will be using the approved facility pad (Dundee 4) under EA: DOI-BLM-NM-P020-2022-1018-EA.
- B. **Buried & Surface Flowlines.** No additional surface disturbance anticipated. Buried four-inch (4") OD HDPE FL and a Three-Inch (3") OD HDPE gas line will run North for 6097.93' between the Koala South Pad and the CTB, and 1195.68' between the Koala North Pad to the CTB. Trenches will be parallel to the Koala North Pad Roads. Permian Resources will be utilizing the existing flowline corridor approved with the original Koala 9 Fed Com permits, under EA: DOI-BLM-NM-P020-2022-1018-EA.
- C. **Midstream Tie-In.** A midstream tie-in is not requested with this project. In the event that a midstream tie-in is necessary, Permian Resources will file application with the appropriate authorities to construct via right-of-way.
- D. **Disposal Facilities.** Produced water will be hauled from location to a commercial disposal facility as needed. Once wells are drilled and completed, a 3160-5 sundry notification will be submitted to BLM in compliance with Onshore Order 7.
- E. **Flare.** A flare is not requested with this project. The flare is collocated on the Dundee 4 Fed Com CTB. No additional surface disturbance is requested.
- F. **Aboveground Structures.** All permanent (on site six months or longer) aboveground structures constructed or installed on location and not subject to safety requirements will be painted earth-tone colors such as 'shale green' that reduce the visual impacts of the built environment.
- G. **Containment Berms.** Containment berms will be constructed completely around any production facilities designed to hold fluids. The containment berms will be constructed of compacted subsoil, be sufficiently impervious, hold 1.5 times the capacity of the largest tank and away from cut or fill areas.
- H. **Electrical.** Electrical is routed to the well pad and central tank battery locations. No additional surface disturbance is requested or anticipated. In the event that an electrical line is identified and determined to be necessary, Permian Resources will submit the appropriate documentation to the BLM utilizing either SF-299 or 3160-5 to be determined by future route.

6. Location and Types of Water Supply

The well will be drilled using a combination of water mud systems as outlined in the Drilling Program. The water will be obtained from a 3rd party vendor and hauled to the anticipated pit by transport truck using the existing and proposed roads depicted in the attached exhibits. No water well will be drilled on the location.

Water for drilling, completion and dust control will be used from the following existing lined pond.

Water for drilling, completion and dust control will be supplied by existing Alfadale water station on private land in SESW 6-T19S-R28E.

Anticipated water usage for drilling includes an estimated 50,000 barrels (bbls) of water to drill a horizontal well in a combination of fresh water and brine as detailed in the mud program in the drilling plans. These volumes are calculated for ~1.5 bbls per foot of hole drilled with excess to accommodate any lost circulation or wash out that may occur. Actual water volumes used during operations will depend on the depth of the well, length of horizontal sections, and the losses that may occur during the operation.

Temporary water flowlines will be permitted via ROW approval letter and proper grants as needed based on drilling and completion schedules. Well completion is expected to require approximately 1,950,000 bbls of water per horizontal well. Actual water volumes used during operations will depend on the depth of the well and length of horizontal sections.

7. Construction Activities

- A. Construction, reclamation, and/or routine maintenance will not be conducted during periods when the soil conditions for construction could lead to impacts to the surrounding environment, or when watershed damage is likely to occur because of these activities.
- B. Any construction material that may be required for surfacing of the drill pad and access road will be from a contractor having a permitted source of materials within the general area. No construction materials will be removed from federal lands without prior approval from the appropriate surface management agency. All roads and well pads will be constructed of 6" rolled and compacted caliche hauled by Constructors Inc.
- C. Anticipated Caliche Locations:
 - a. Pit 1: Private Caliche Pit, Section 18-T18S-R28E, SENE

8. Methods for Handling Waste

- **Cuttings.** The well will be drilled utilizing a closed-loop mud system. Drill cuttings will be held in roll-off style mud boxes and taken to a New Mexico Oil Conservation Division (NMOCD) approved disposal site.
- **Drilling Fluids.** These will be contained in steel mud pits and then taken to a NMOCD approved commercial disposal facility.
- **Produced Fluids.** Water produced from the well during completion will be held temporarily in steel tanks and then taken to a NMOCD approved commercial disposal facility. Oil produced during operations will be stored in tanks until sold.
- **Sewage.** Portable, self-contained toilets will be provided for human waste disposal. Upon completion of drilling and completion activities, or as required, the toilet holding tanks will be pumped and the contents thereof disposed of in an approved sewage disposal facility. All state and local laws and regulations pertaining to the disposal of human and solid waste will be complied with. This equipment will be properly maintained during the drilling and completion operations and will be removed when all operations are complete.
- **Garbage and Other Waste Materials.** All garbage, junk and non-flammable waste materials will be contained in a self-contained, portable dumpster or trash cage, to prevent scattering and will be removed and deposited in an approved sanitary landfill. Immediately after drilling all debris and other waste materials on and around the well location not contained in the trash cage will be cleaned up and removed from the location. No potentially adverse materials or substances will be left on the location.
- **Debris.** Immediately after removal of the drilling rig, all debris and other waste materials not contained in the trash cage will be cleaned and removed from the well location. No potential adverse materials or substances will be left on location.
- **Hazardous Materials.**
 - i. All drilling wastes identified as hazardous substances by the Comprehensive Environmental Response Compensation Liability Act (CERCLA) removed from the location, and not reused at another drilling location, will be disposed of at a hazardous waste facility approved by the U.S. Environmental Protection Agency (EPA).
 - ii. Permian Resources and its contractors will comply with all applicable Federal, State and local laws and regulations, existing or hereafter enacted/promulgated, with regard to any hazardous material, as defined in this paragraph, that will be used, produced, transported or stored on the oil and gas lease. "Hazardous material" means any substance, pollutant or contaminant that is listed as hazardous under the CERCLA of 1980, as amended, 42 U.S.C 9601 et seq., and its regulation. The definition of hazardous substances under

CERCLA includes any "hazardous waste" as defined in the RCRA of 1976, as amended, 42 U.S.C. 6901 et seq., and its regulations. The term hazardous material also includes any nuclear or nuclear by-product material as defined by the Atomic Energy Act of 1954, as amended, 42 U.S.C. 2011 et seq. The term does not include petroleum, including crude oil or any fraction thereof that is not otherwise specifically listed or designated as a hazardous substance under CERCLA Section 101 (14) U.S.C. 9601 (14) nor does the term include natural gas.

- iii. No hazardous substances or wastes will be stored on the location after completion of the well.
- iv. Chemicals brought to location will be on the Toxic Substance Control Act (TSCA) approved inventory list.
- v. All undesirable events (fires, accidents, blowouts, spills, discharges) as specified in Notice to Lessees (NTL) 3A will be reported to the BLM Carlsbad Field Office. Major events will be reported verbally within 24 hours, followed by a written report within 15 days. "Other than Major Events" will be reported in writing within 15 days.

9. Well Site Layout

1. **Rig Plat Diagrams:** No additional surface disturbance is requested or anticipated. The well will be located on an existing well pad previously approved under DOI-BLM-NM-P020-2022-1018-EA. There are 8 wells proposed on the well two (2) well pads with this application. The existing pad will allow enough space for cuts and fills, topsoil storage, and storm water control and sizes are approximations based on these needs. Interim reclamation of this pad is anticipated after the drilling and completion of all wells on the pad. The well site layout for the pad indicating temporary workspace and topsoil stockpile location is attached.
 - Pad 1 Permitted Pad Size in EA: 500'x500' (5.740 Acres)
 - Center Point: 864' FNL, 477' FEL, NENE-Sec 8-T20S-R28E
 - Pad 1 Permitted Pad Size in EA: 500'x500' (5.740 Acres)
 - Center Point: 1074' FSL, 250' FEL, SESE-Sec 8-T20S-R28E
2. **Closed-Loop System:** There will be no reserve pit as each well will be drilled utilizing a closed loop mud system. The closed loop system will meet the NMOCD requirements 19.15.17.
3. **V-Door Orientation:** This pad was staked with east v-door orientation. The following pad is in accordance with the staked section and as agreed upon with Jeffery Robertson, BLM Natural Resource Specialist, present at on-site inspection April 6, 2022.
 - Pad 1 has a V-Door Orientation: East
 - Pad 2 has a V-Door Orientation: East
4. All equipment and vehicles will be confined to the approved disturbed areas of this APD (i.e., access road, well pad and topsoil storage areas).

5. Plans for Surface Reclamation:

Permian Resources requests a variance from interim reclamation until all drilling and completion activities have been finished on the pads as these are multi-well pads where drilling and completion will be consecutive with the other wells on the pad. Once activities are completed, Permian Resource. will coordinate interim reclamation with the appropriate BLM personnel or use the following plan:

Non-Commercial Well (Not Productive), Interim & Final Reclamation:

Definition: Reclamation includes disturbed areas where the original landform and a natural vegetative community will be restored, and it is anticipated the site will not be disturbed for future development.

Reclamation Standards:

The portions of the pad not essential to production facilities or space required for workover operations will be reclaimed and seeded as per BLM requirements for interim reclamation. (See Interim Reclamation plats attached).

All equipment and trash will be removed, and the surfacing material will be removed from the well pad and road and transported to the original caliche pit or used to maintain other roads. The location will then be ripped and seeded.

The original stock piled topsoil will be spread over the areas being reclaimed and the original landform will be restored for all disturbed areas including well pads, production facilities, roads, pipelines, and utility corridors as close as possible to the original topography. The location will then be ripped and seeded.

A self-sustaining, vigorous, diverse, native (or otherwise approved) plant community will be established on the site with a density sufficient to control erosion and invasion by non-native plants and to re-establish wildlife habitat or forage production. At a minimum, the established plant community will consist of species included in the seed mix and/or desirable species occurring in the surrounding natural vegetation.

Erosion features are equal to or less than surrounding area and erosion control is sufficient so that water naturally infiltrates into the soil and gulying, headcutting, slumping, and deep or excessive rills (greater than 3 inches) are not observed.

The site will be free of State or County listed noxious weeds, oil field debris and equipment, and contaminated soil. Invasive and non-native noxious weeds will be controlled.

Seeding:

- **Seedbed Preparation:** Initial seedbed preparation will consist of recontouring to the appropriate interim or final reclamation standard. All compacted areas to be seeded will be ripped to a minimum depth of 18 inches with a minimum furrow spacing of 2 feet, followed by recontouring the surface and then evenly spreading the stockpiled topsoil. Prior to seeding, the seedbed will be scarified to a depth of no less than 4-6 inches. If the site is to be broadcast seeded, the surface will be left rough enough to trap seed and snow, control erosion, and increase water infiltration.
- If broadcast seeding is to be used and is delayed, final seedbed preparation will consist of contour cultivating to a depth of 4-6 inches within 24 hours prior to seeding, dozer tracking, or other imprinting in order to break the soil crust and create seed germination micro-sites.
- **Seed Application.** Seeding will be conducted no more than two weeks following completion of final seedbed preparation. A certified weed-free seed mix designed by the BLM to meet reclamation standards will be used.
- If the site is harrowed or dragged, seed will be covered by no more than 0.25 inch of soil.

6. Surface Ownership

- A. 100% of the Koala 9 Fed Com project area is under the administrative jurisdiction of the Bureau of Land Management.
- B. The surface is multiple use with the primary uses of the region for grazing and to produce oil and gas.

12. Other Information

- **Cultural Resources – Archaeology:** Lonestar Mountain Archaeological conducted block inspections and filed reports NMCEIS-149416 on December 27, 2021 and NMCRIS-149810 on March 30, 2022. The report is on file with the BLM based on the previous project surface disturbance approval. Onsite was conducted April 6, 2022 with Jeff Robertson Bureau of Land Management NRS.
- **Dwellings and Structures.** There are no dwellings or structures within 2 miles of this location.

Surveying

- **Well Sites.** Well pad locations have been construction. Surveys of the access roads and well pad locations have been completed by Transglobal, a registered professional land surveyor. Center stake surveys with access roads have been completed on Federal lands with Jeff Robertson, Bureau of Land Management Natural Resource Specialist, in attendance April 6, 2022.

Soils and Vegetation

- **Environmental Setting.** Soils are classified as Reeves soils. These soils are associated with the loamy ecological site which typically supports black and blue grama and tobosa grasslands with an even distribution of yucca, mesquite, American tarbush, cholla, and creosote.
- **Traffic.** No truck traffic will be operated during periods or in areas of saturated ground when surface rutting could occur. The access road will be constructed and maintained as necessary to prevent soil erosion and accommodate all-weather traffic. The road will be crowned and ditched with water turnouts installed as necessary to provide for proper drainage along the access road route.
- **Water.** There is no permanent or live water in the immediate or within the project area.

13. Bond Coverage

Bond Coverage is Nationwide. Bond Number: NMB001841

Operator's Representatives:

The Permian Resources representatives for ensuring compliance of the surface use plan are listed below:

Surface:

Cade LaBolt
Senior Surface Landman
Permian Resources
300 N. Marienfeld Street, Suite 1000
Midland, Texas 79701
330-607-9741
cade.labolt@permianres.com

Onsite: April 6, 2022, with Jeff Robertson, Bureau of Land Management NRS.

APD ID: 10400108077	Submission Date: 10/30/2025
Operator Name: PERMIAN RESOURCES OPERATING LLC	
Well Name: KOALA 9 FED COM	Well Number: 124H
Well Type: CONVENTIONAL GAS WELL	Well Work Type: Drill

Section 1 - General

Would you like to address long-term produced water disposal? NO

Section 2 - Lined

Would you like to utilize Lined Pit PWD options? N

Produced Water Disposal (PWD) Location:

PWD surface owner:

PWD disturbance (acres):

Other PWD Surface Owner Description:

Lined pit PWD on or off channel:

Lined pit PWD discharge volume (bbl/day):

Lined pit

Pit liner description:

Pit liner manufacturers

Precipitated solids disposal:

Decribe precipitated solids disposal:

Precipitated solids disposal

Lined pit precipitated solids disposal schedule:

Lined pit precipitated solids disposal schedule

Lined pit reclamation description:

Lined pit reclamation

Leak detection system description:

Leak detection system

Well Name: KOALA 9 FED COM

Well Number: 124H

Lined pit Monitor description:

Lined pit Monitor

Lined pit: do you have a reclamation bond for the pit?

Is the reclamation bond a rider under the BLM bond?

Lined pit bond number:

Lined pit bond amount:

Additional bond information

Section 3 - Unlined

Would you like to utilize Unlined Pit PWD options? N

Produced Water Disposal (PWD) Location:

PWD disturbance (acres): PWD surface owner:

Other PWD Surface Owner Description:

Unlined pit PWD on or off channel:

Unlined pit PWD discharge volume (bbl/day):

Unlined pit

Precipitated solids disposal:

Describe precipitated solids disposal:

Precipitated solids disposal

Unlined pit precipitated solids disposal schedule:

Unlined pit precipitated solids disposal schedule

Unlined pit reclamation description:

Unlined pit reclamation

Unlined pit Monitor description:

Unlined pit Monitor

Do you propose to put the produced water to beneficial use?

Beneficial use user

Estimated depth of the shallowest aquifer (feet):

Precipitated Solids Permit

Does the produced water have an annual average Total Dissolved Solids (TDS) concentration equal to or less than that of the existing water to be protected?

TDS lab results:

Geologic and hydrologic

Well Name: KOALA 9 FED COM

Well Number: 124H

State

Unlined Produced Water Pit Estimated

Unlined pit: do you have a reclamation bond for the pit?

Is the reclamation bond a rider under the BLM bond?

Unlined pit bond number:

Unlined pit bond amount:

Additional bond information

Section 4 -

Would you like to utilize Injection PWD options? N

Produced Water Disposal (PWD) Location:

PWD surface owner:

PWD disturbance (acres):

Other PWD Surface Owner Description:

Injection PWD discharge volume (bbl/day):

Injection well mineral owner:

Injection well type:

Injection well number:

Injection well name:

Assigned injection well API number?

Injection well API number:

Injection well new surface disturbance (acres):

Minerals protection information:

Mineral protection

Underground Injection Control (UIC) Permit?

UIC Permit

Section 5 - Surface

Would you like to utilize Surface Discharge PWD options? N

Produced Water Disposal (PWD) Location:

PWD surface owner:

PWD disturbance (acres):

Other PWD Surface Owner Description :

Surface discharge PWD discharge volume (bbl/day):

Surface Discharge NPDES Permit?

Surface Discharge NPDES Permit attachment:

Surface Discharge site facilities information:

Surface discharge site facilities map:

Well Name: KOALA 9 FED COM

Well Number: 124H

Section 6 -

Would you like to utilize Other PWD options? N

Produced Water Disposal (PWD) Location:

PWD surface owner:

PWD disturbance (acres):

PWD Surface Owner Description:

Other PWD discharge volume (bbl/day):

Other PWD type description:

Other PWD type

Have other regulatory requirements been met?

Other regulatory requirements

APD ID: 10400108077

Submission Date: 10/30/2025

Highlighted data
reflects the most
recent changes
[Show Final Text](#)

Operator Name: PERMIAN RESOURCES OPERATING LLC

Well Name: KOALA 9 FED COM

Well Number: 124H

Well Type: CONVENTIONAL GAS WELL

Well Work Type: Drill

Bond

Federal/Indian APD: FED

BLM Bond number: NMB001841

BIA Bond number:

Do you have a reclamation bond? NO

Is the reclamation bond a rider under the BLM bond?

Is the reclamation bond BLM or Forest Service?

BLM reclamation bond number:

Forest Service reclamation bond number:

Forest Service reclamation bond attachment:

Reclamation bond amount:

Reclamation bond rider amount:

Additional reclamation bond information attachment:

Sante Fe Main Office
Phone: (505) 476-3441

General Information
Phone: (505) 629-6116

Online Phone Directory
<https://www.emnrd.nm.gov/ocd/contact-us>

State of New Mexico
Energy, Minerals and Natural Resources
Oil Conservation Division
1220 S. St Francis Dr.
Santa Fe, NM 87505

ACKNOWLEDGMENTS

Action 546530

ACKNOWLEDGMENTS

Operator: Permian Resources Operating, LLC 300 N. Marienfeld St Ste 1000 Midland, TX 79701	OGRID: 372165
	Action Number: 546530
	Action Type: [C-101] BLM - Federal/Indian Land Lease (Form 3160-3)

ACKNOWLEDGMENTS

<input checked="" type="checkbox"/>	I hereby certify that no additives containing PFAS chemicals will be added to the completion or recompletion of this well.
-------------------------------------	--

Sante Fe Main Office
Phone: (505) 476-3441

General Information
Phone: (505) 629-6116

Online Phone Directory
<https://www.emnrd.nm.gov/oecd/contact-us>

State of New Mexico
Energy, Minerals and Natural Resources
Oil Conservation Division
1220 S. St Francis Dr.
Santa Fe, NM 87505

CONDITIONS

Action 546530

CONDITIONS

Operator: Permian Resources Operating, LLC 300 N. Marienfeld St Ste 1000 Midland, TX 79701	OGRID: 372165
	Action Number: 546530
	Action Type: [C-101] BLM - Federal/Indian Land Lease (Form 3160-3)

CONDITIONS

Created By	Condition	Condition Date
clevans	Cement is required to circulate on both surface and intermediate1 strings of casing.	1/26/2026
clevans	If cement does not circulate on any string, a Cement Bond Log (CBL) is required for that string of casing.	1/26/2026
ward.rikala	Notify the OCD 24 hours prior to casing & cement.	2/9/2026
ward.rikala	File As Drilled C-102 and a directional Survey with C-104 completion packet.	2/9/2026
ward.rikala	Once the well is spud, to prevent ground water contamination through whole or partial conduits from the surface, the operator shall drill without interruption through the fresh water zone or zones and shall immediately set in cement the water protection string.	2/9/2026
ward.rikala	Oil base muds are not to be used until fresh water zones are cased and cemented providing isolation from the oil or diesel. This includes synthetic oils. Oil based mud, drilling fluids and solids must be contained in a steel closed loop system.	2/9/2026
ward.rikala	Administrative order required for non-standard location prior to production.	2/9/2026
ward.rikala	A [C-103] Sub. Drilling (C-103N) is required within (10) days of spud.	2/9/2026
ward.rikala	This well is within the Capitan Reef. The first intermediate casing string shall be sat and cemented back to surface immediately above the Capitan Reef. The second intermediate string shall be set and cemented back to surface immediately below the base of the Capitan Reef.	2/9/2026