

Office
District I - (575) 393-6161
1625 N. French Dr., Hobbs, NM 88240
District II - (575) 748-1283
811 S. First St., Artesia, NM 88210
District III - (505) 334-6178
1000 Rio Brazos Rd., Aztec, NM 87410
District IV - (505) 476-3460
1220 S. St. Francis Dr., Santa Fe, NM 87505

State of New Mexico
Energy, Minerals and Natural Resources

Form C-103
Revised July 18, 2013

OIL CONSERVATION DIVISION
1220 South St. Francis Dr.
Santa Fe, NM 87505

WELL API NO.
5. Indicate Type of Lease
STATE [] FEE []
6. State Oil & Gas Lease No.
7. Lease Name or Unit Agreement Name
8. Well Number
9. OGRID Number
10. Pool name or Wildcat
11. Elevation (Show whether DR, RKB, RT, GR, etc.)

SUNDRY NOTICES AND REPORTS ON WELLS
(DO NOT USE THIS FORM FOR PROPOSALS TO DRILL OR TO DEEPEN OR PLUG BACK TO A DIFFERENT RESERVOIR. USE "APPLICATION FOR PERMIT" (FORM C-101) FOR SUCH PROPOSALS.)
1. Type of Well: Oil Well [] Gas Well [] Other []
2. Name of Operator
3. Address of Operator
4. Well Location
Unit Letter _____ : _____ feet from the _____ line and _____ feet from the _____ line
Section _____ Township _____ Range _____ NMPM _____ County _____

12. Check Appropriate Box to Indicate Nature of Notice, Report or Other Data

NOTICE OF INTENTION TO:
PERFORM REMEDIAL WORK [] PLUG AND ABANDON []
TEMPORARILY ABANDON [] CHANGE PLANS []
PULL OR ALTER CASING [] MULTIPLE COMPL []
DOWNHOLE COMMINGLE []
CLOSED-LOOP SYSTEM []
OTHER: []
SUBSEQUENT REPORT OF:
REMEDIAL WORK [] ALTERING CASING []
COMMENCE DRILLING OPNS. [] P AND A []
CASING/CEMENT JOB []
OTHER: []

13. Describe proposed or completed operations. (Clearly state all pertinent details, and give pertinent dates, including estimated date of starting any proposed work). SEE RULE 19.15.7.14 NMAC. For Multiple Completions: Attach wellbore diagram of proposed completion or recompletion.

THE IS A LATE FILING OF PERFORATIONS THAT WERE ADDED IN 2017. SEE ATTACHED WELLBORE AND JOB NOTES.

Spud Date: []

Rig Release Date: []

I hereby certify that the information above is true and complete to the best of my knowledge and belief.

SIGNATURE Stephen Janacek TITLE DATE

Type or print name E-mail address: PHONE:

For State Use Only

APPROVED BY: TITLE DATE

Conditions of Approval (if any):

OXY USA INC.

LOST TANK 35 STATE 011

30-015-32240

ADDITIONAL PERFORATIONS ADDED 12/13/2017

RIG NOTES FROM JOB

13 Dec 2017	12-13-17 LT35-11 BASIC-1754 CASEY FREEMAN D.C. = 20,699.00 ACC. =57,534.00 AOL HAVE TGSM AND HAZARD HUNT IWP=15# OPEN TO PIT AND PUMP 15 BBL FOR WELL CONTROL. RIH WITH WIRELINE GR & C CL CONFIRM DEPTH AND PERF CSG @8103 TO 8105 AND @ 7940 TO 7942. WELL PRESSURE NEVER CHANGED. POOH CHANGE TOOLS PICK UP 5.5 AIROSET WATSON PACKER RIG SET @7888 (CONFIRM NOT IN COLLAR) POOH RDMO WIRELINE. MIRU TBG TESTER PICK UP AND TEST IN HOLE WITH 151 JTS OF 3.5 TBG. SECURE LOCATION SHUT DOWN. NDP= RIH WITH TBG, RIG UP FRACK STACK
-------------	---

ADDITIONAL PERFORATIONS

Component Name	↑ Top MD	Bottom MD
Perforations	7,940	7,942
Perforations	8,103	8,105

CURRENT WELLBORE

Sean Lehle
11/5/2025
30-015-32240-0000
Eddy

Current Wellbore
LOST TANK 35 STATE 011

String 1
OD 13.375 in, 48# H-40 ST&C
TD 829 ft
TOC 0 ft, 900 SX, CIRC 180 SX

String 2
OD 8.625 in, 32# J-55 ST&C
TD 4100 ft
TOC 0 ft, 3140 SX, CIRC 107 SX

String 3
OD 5.5 in, 15.5# & 17# J-55 LT&C
TD 8350 ft
TOC 0 ft, 1820 SX, CIRC 191 SX
PBTD 8265 ft

Anhydrite 3546'
DV Tool
Top 3607 ft

Delaware 4225'
Bell Canyon 4332'

Cherry Canyon 5231'

DV Tool
Top 6015 ft

Brushy Canyon 6503'

Prod Zone
6916 - 6928 ft

Bone Spring 8152'

Prod Zone
7940 - 7942 ft
8102 - 8105 ft

Tubing Assembly
OD 2.875 in
Top 0 ft
Bot 8104 ft

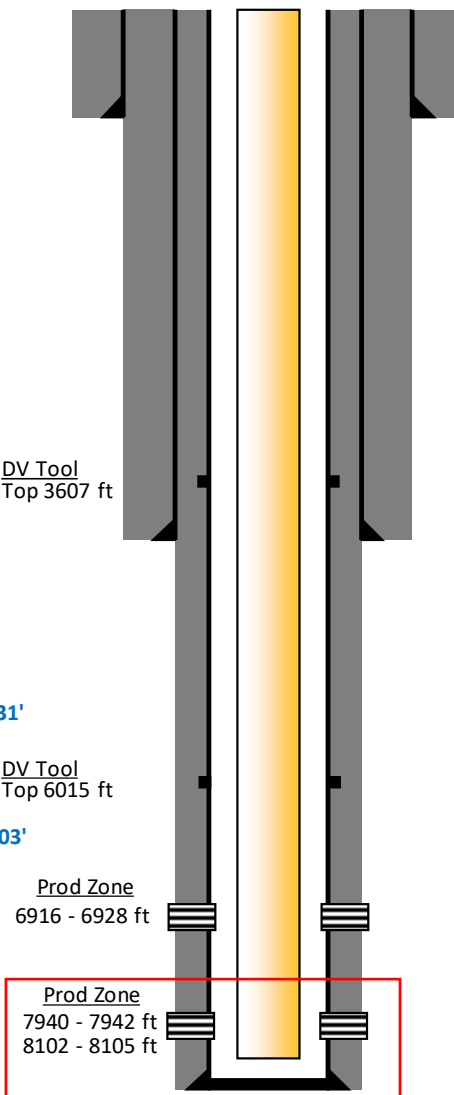

PERFS ADDED IN 2017

Sante Fe Main Office
Phone: (505) 476-3441

General Information
Phone: (505) 629-6116

Online Phone Directory
<https://www.emnrd.nm.gov/oed/contact-us>

State of New Mexico
Energy, Minerals and Natural Resources
Oil Conservation Division
1220 S. St Francis Dr.
Santa Fe, NM 87505

CONDITIONS

Action 525132

CONDITIONS

Operator: OXY USA INC P.O. Box 4294 Houston, TX 772104294	OGRID: 16696
	Action Number: 525132
	Action Type: [C-103] Sub. Workover (C-103R)

CONDITIONS

Created By	Condition	Condition Date
gcordero	• This well was perforated without prior approval or notification to OCD.	2/11/2026