

Sante Fe Main Office
Phone: (505) 476-3441

General Information
Phone: (505) 629-6116

Online Phone Directory
<https://www.emnrd.nm.gov/ocd/contact-us>

State of New Mexico
Energy, Minerals and Natural Resources
Oil Conservation Division
1220 S. St Francis Dr.
Santa Fe, NM 87505

Form C-101
August 1, 2011
Permit 383326

APPLICATION FOR PERMIT TO DRILL, RE-ENTER, DEEPEN, PLUGBACK, OR ADD A ZONE

1. Operator Name and Address MEWBOURNE OIL CO P.O. Box 5270 Hobbs, NM 88241		2. OGRID Number 14744
4. Property Code 337202		3. API Number 30-015-57852
5. Property Name RUNWAY 26/30 FED COM		6. Well No. 822H

7. Surface Location

UL - Lot I	Section 27	Township 22S	Range 26E	Lot Idn I	Feet From 1820	N/S Line S	Feet From 225	E/W Line E	County Eddy
---------------	---------------	-----------------	--------------	--------------	-------------------	---------------	------------------	---------------	----------------

8. Proposed Bottom Hole Location

UL - Lot A	Section 30	Township 22S	Range 27E	Lot Idn A	Feet From 990	N/S Line N	Feet From 330	E/W Line E	County Eddy
---------------	---------------	-----------------	--------------	--------------	------------------	---------------	------------------	---------------	----------------

9. Pool Information

PURPLE SAGE;WOLFCAMP (GAS)	98220
----------------------------	-------

Additional Well Information

11. Work Type New Well	12. Well Type GAS	13. Cable/Rotary	14. Lease Type State	15. Ground Level Elevation 3229
16. Multiple N	17. Proposed Depth 25496	18. Formation 2nd Bone Spring Sand	19. Contractor	20. Spud Date 10/20/2024
Depth to Ground water		Distance from nearest fresh water well		Distance to nearest surface water

We will be using a closed-loop system in lieu of lined pits

21. Proposed Casing and Cement Program

Type	Hole Size	Casing Size	Casing Weight/ft	Setting Depth	Sacks of Cement	Estimated TOC
Surf	17.5	13.375	48	600	470	0
Int1	12.25	9.625	36	1800	410	0
Prod	8.75	7	29.7	9111	630	1600
Liner1	6.125	5.5	20	25496	940	8911

Casing/Cement Program: Additional Comments

MOC proposed to drill & test the Bone Springs formation. H2S rule 118 does not apply because MOC has researched the area & no high concentrations were found. Will have on location & working all H2S safety equipment before Yates formation for safety & insurance purposes. Will stimulate as needed for production.

22. Proposed Blowout Prevention Program

Type	Working Pressure	Test Pressure	Manufacturer
Annular	5000	2500	SCHAFFER
Double Ram	5000	5000	SHCAFFER
Annular	5000	2500	SHCAFFER

23. I hereby certify that the information given above is true and complete to the best of my knowledge and belief. I hereby certify that no additives containing PFAS chemicals will be added to the completion or recompletion of this well. I further certify I have complied with 19.15.14.9 (A) NMAC <input checked="" type="checkbox"/> and/or 19.15.14.9 (B) NMAC <input checked="" type="checkbox"/> if applicable.	OIL CONSERVATION DIVISION
Signature:	
Printed Name: Electronically filed by Monty Whetstone	Approved By: Jeffrey Harrison
Title: Vice President Operations	Title: Petroleum Specialist III
Email Address: fking@mewbourne.com	Approved Date: 2/20/2026 Expiration Date: 2/20/2028
Date: 2/16/2026 Phone: 903-561-2900	Conditions of Approval Attached

ACREAGE DEDICATION PLATS

This grid represents a standard section. You may superimpose a non-standard section, or larger area, over this grid. Operators must outline the dedicated acreage in a red box, clearly show the well surface location and bottom hole location, if it is a directionally drilled, with the dimensions from the section lines in the cardinal directions. If this is a horizontal wellbore show on this plat the location of the First Take Point and Last Take Point, and the point within the Completed interval (other than the First Take Point or Last Take Point) that is closest to any outer boundary of the tract.

Surveyors shall use the latest United States government survey or dependent resurvey. Well locations will be in reference to the New Mexico Principal Meridian. If the land is not surveyed, contact the OCD Engineering Bureau. Independent subdivision surveys will not be acceptable.

RUNWAY 26/30 FED COM #822H

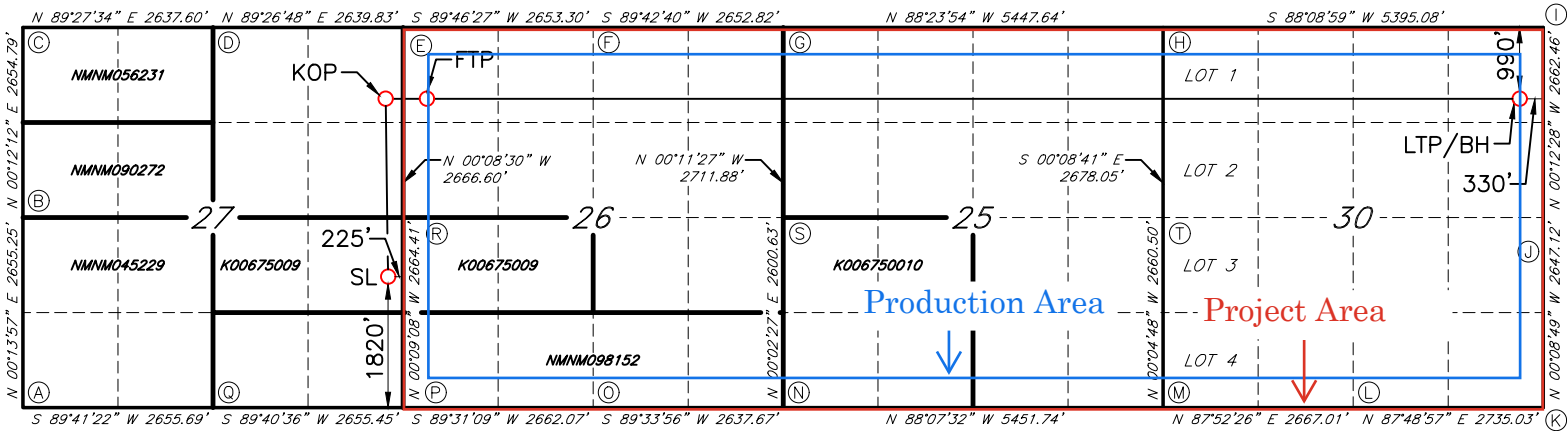

CORNER DATA
NAD 83 GRID - NM EAST

- | | | |
|---|--|---|
| <p><u>GEODETIC DATA</u>
NAD 83 GRID - NM EAST</p> <p><u>SURFACE LOCATION (SL)</u>
N: 495094.0 - E: 559909.1</p> <p>LAT: 32.3610693° N
LONG: 104.2731858° W</p> <p><u>KICK OFF POINT (KOP)</u>
990' FNL - 243' FEL SEC. 27
N: 497613.3 - E: 559884.7</p> <p>LAT: 32.3679945° N
LONG: 104.2732602° W</p> <p><u>FIRST TAKE POINT (FTP)</u>
990' FNL - 330' FWL SEC. 26
N: 497616.9 - E: 560457.6</p> <p><u>LAST TAKE POINT/BOTTOM HOLE (LTP/BH)</u>
N: 497650.7 - E: 575939.0</p> <p>LAT: 32.3680619° N
LONG: 104.2212614° W</p> | <p>A: FOUND BRASS CAP "1943"
N: 493246.3 - E: 554829.1</p> <p>B: FOUND BRASS CAP "1943"
N: 495900.9 - E: 554839.9</p> <p>C: FOUND BRASS CAP "1943"
N: 498555.0 - E: 554849.3</p> <p>D: FOUND BRASS CAP "1943"
N: 498579.9 - E: 557486.1</p> <p>E: FOUND 1" PIPE W/CAP
STAMPED "PS5412"
N: 498605.4 - E: 560125.2</p> <p>F: FOUND BRASS CAP "1943"
N: 498615.8 - E: 562777.8</p> <p>G: CALCULATED CORNER
N: 498629.2 - E: 565430.0</p> <p>H: CALCULATED CORNER
N: 498477.0 - E: 570874.2</p> <p>I: FOUND COTTON SPINDLE
N: 498651.1 - E: 576265.1</p> <p>J: FOUND COTTON SPINDLE
N: 495989.3 - E: 576274.8</p> <p>K: FOUND 1/2" REBAR
N: 493342.8 - E: 576281.6</p> | <p>L: FOUND 1/4" REBAR
W/PLASTIC CAP "REDDY PS5412"
N: 493238.6 - E: 573549.2</p> <p>M: FOUND COTTON SPINDLE
N: 493139.7 - E: 570884.7</p> <p>N: FOUND 3/4" REBAR
W/PLASTIC CAP "REDDY PS5412"
N: 493318.0 - E: 565437.2</p> <p>O: FOUND BRASS CAP "1943"
N: 493298.0 - E: 562800.2</p> <p>P: FOUND BRASS CAP "1943"
N: 493275.7 - E: 560138.9</p> <p>Q: FOUND BRASS CAP "1943"
N: 493260.7 - E: 557484.1</p> <p>R: FOUND BRASS CAP "1943"
N: 495939.4 - E: 560131.8</p> <p>S: FOUND 1/2" REBAR
W/ALUMINUM CAP "REDDY PS5412"
N: 495918.0 - E: 565439.0</p> <p>T: FOUND 1/2" REBAR
W/ALUMINUM CAP "PE-PS5412"
N: 495799.6 - E: 570880.9</p> |
|---|--|---|

Sante Fe Main Office
Phone: (505) 476-3441

General Information
Phone: (505) 629-6116

Online Phone Directory
<https://www.emnrd.nm.gov/ocd/contact-us>

State of New Mexico
Energy, Minerals and Natural Resources
Oil Conservation Division
1220 S. St Francis Dr.
Santa Fe, NM 87505

Form APD Conditions

Permit 383326

PERMIT CONDITIONS OF APPROVAL

Operator Name and Address: MEWBOURNE OIL CO [14744] P.O. Box 5270 Hobbs, NM 88241	API Number: 30-015-57852
	Well: RUNWAY 26/30 FED COM #822H

OCD Reviewer	Condition
jeffrey.harrison	No additives containing PFAS chemicals will be added to the drilling fluids or completion fluids used during drilling, completions, or recompletions operations.
jeffrey.harrison	NSP required if not included in an existing order or not an infill to an appropriate defining well in the same pool and spacing unit.
jeffrey.harrison	Cement is required to circulate on both surface and intermediate1 strings of casing.
jeffrey.harrison	If the method of isolation was not by circulation, a CBL must be performed; if strata isolation is not achieved, then remediation will be required before further operations.
jeffrey.harrison	File As Drilled C-102 and a directional Survey with C-104 completion packet.
jeffrey.harrison	Notify the OCD 24 hours prior to casing & cement.
jeffrey.harrison	A [C-103] Sub. Drilling (C-103N) is required within (10) days of spud.
jeffrey.harrison	Once the well is spud, to prevent ground water contamination through whole or partial conduits from the surface, the operator shall drill without interruption through the fresh water zone or zones and shall immediately set in cement the water protection string.
jeffrey.harrison	Oil base muds are not to be used until fresh water zones are cased and cemented providing isolation from the oil or diesel. This includes synthetic oils. Oil based mud, drilling fluids and solids must be contained in a steel closed loop system.



Mewbourne Oil Co.

BOP Break Testing Variance

Mewbourne Oil Company requests a variance from the minimum standards for well control equipment testing of 43 CFR 3172 to allow a testing schedule of the blow out preventer (BOP) and blow out prevention equipment (BOPE) along with batch drilling & offline cementing operations. Modern rig upgrades which facilitate pad drilling allow the BOP stack to be moved between wells on a multi-well pad without breaking any BOP stack components apart. Widespread use of these technologies has led to break testing BOPE being endorsed as safe and reliable. American Petroleum Institute (API) best practices are frequently used by regulators to develop their regulations. API Standard 53, *Well Control Equipment Systems for Drilling Wells* (5th Ed., Dec. 2018) Section 5.3.7.1 states "A pressure test of the pressure containing component shall be performed following the disconnection or repair, limited to the affected component."

Procedures

1. Full BOPE test at first installation on the pad.
 - Full BOPE test at least every 21 days.
 - Function test BOP elements per 43 CFR 3172.
 - Contact the BLM if a well control event occurs.
2. After the well section is secured and the well is confirmed to be static, the BOP will be disconnected from the wellhead and walked with the rig to another well on the pad. Two breaks on the BOPE will be made (Fig. 1).
 - Connection between the flex line and the HCR valve
 - Connection between the wellhead and the BOP quick connect (Fig. 5 & 6).
3. A capping flange will be installed after cementing per wellhead vendor procedure & casing pressure will be monitored via wellhead valve.
4. The BOP will be removed and carried by a hydraulic carrier (Fig. 3 & 4).
5. The rig will then walk to the next well.
6. Confirm that the well is static and remove the capping flange.
7. The connection between the flex line and HCR valve and the connection between the wellhead and the BOP quick connect will be reconnected.
8. Install a test plug into the wellhead.
9. A test will then be conducted against the upper pipe rams and choke, testing both breaks (Fig. 1 & 2).
10. The test will be held at 250 psi low and to the high value submitted in the APD, not to exceed 5000 psi.
11. The annular, blind rams and lower pipe rams will then be function tested.
12. If a pad consists of three or more wells, steps 4 through 11 will be repeated.



13. A break test will only be conducted if the intermediate section can be drilled and cased within 21 days of the last full BOPE test.

Barriers

Before Nipple Down:

- Floats in casing
- Kill weight fluid in casing
- Kill weight fluid in annulus
- Solid body mandrel and/or packoff

After Nipple Down:

- Floats in casing
- Kill weight fluid in casing
- Kill weight fluid in annulus
- Solid body mandrel and/or packoff
- Offline cementing tool and/or cement head
- Capping flange after cementing

Summary

A variance is requested to only test broken pressure seals on the BOPE when moving between wells on a multi-well pad if the following conditions are met:

- A full BOPE test is conducted on the first well on the pad. API Standard 53 requires testing annular BOP to 70% of RWP or 100% of MASP, whichever is greater.
- If the first well on the pad is not the well with the deepest intermediate section, a full BOPE test will also be performed when moving to a deeper well.
- The hole section being drilled has a MASP under 5000 psi.
- If a well control event occurs, Mewbourne will contact BLM for permission to continue break testing.
- If significant (>50%) losses occur, full BOPE testing will be required going forward.
- Full BOPE test will be required prior to drilling the production hole.

While walking the rig, the BOP stack will be secured via hydraulic winch or hydraulic carrier. A full BOPE test will be performed at least every 21 days.

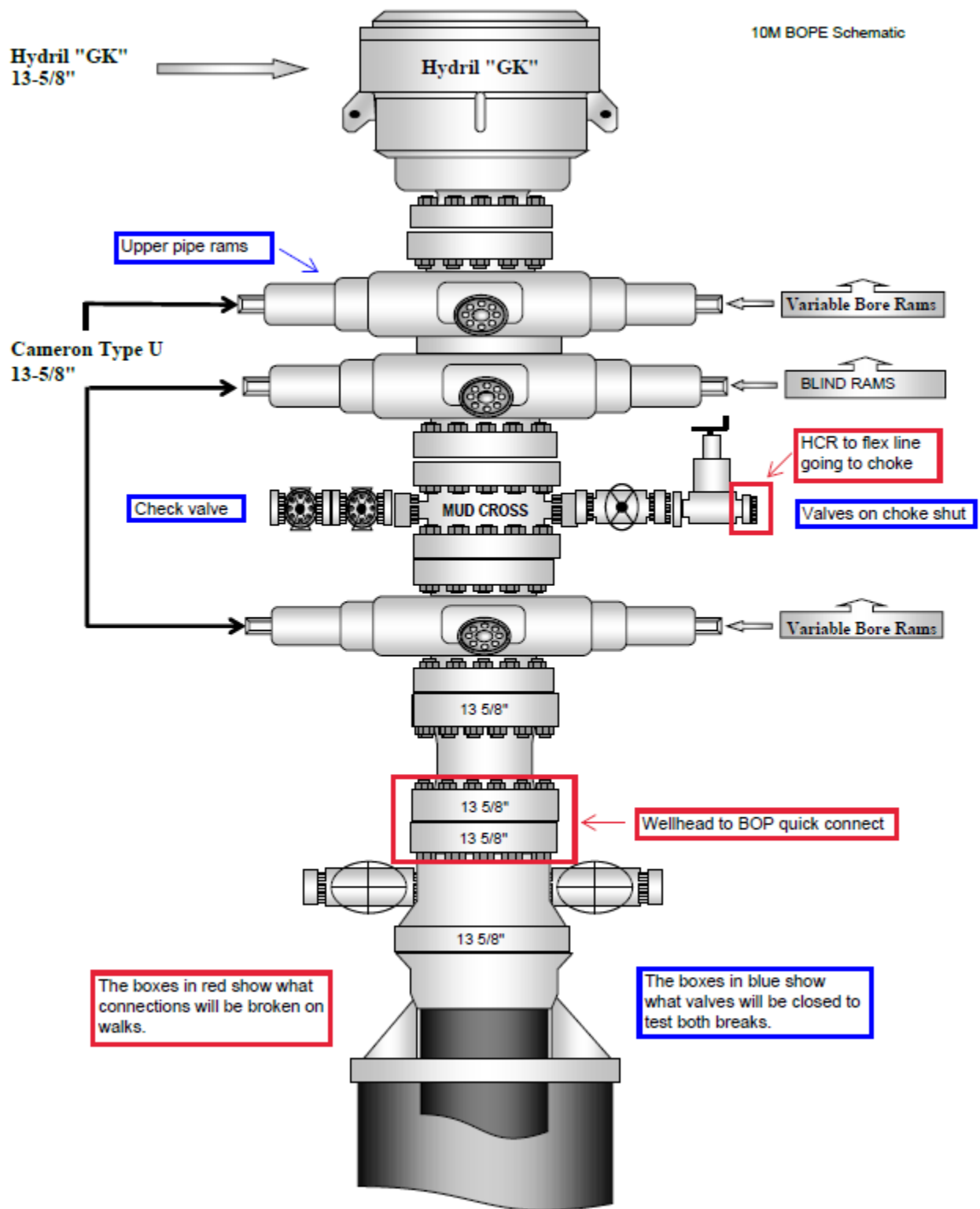
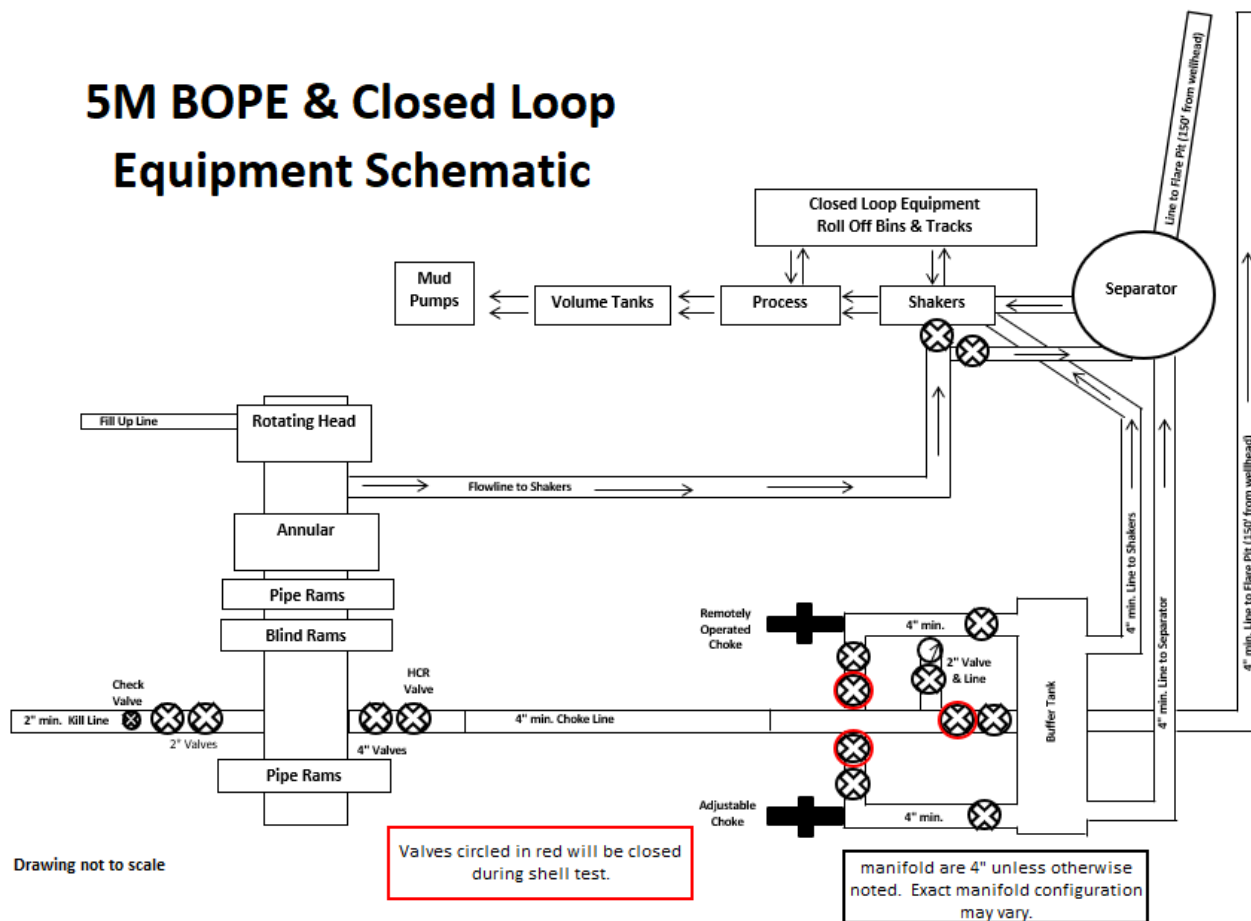

Figure 1. BOP diagram



5M BOPE & Closed Loop Equipment Schematic



Drawing not to scale

Figure 2. BOPE diagram



Figure 3. BOP handling system



Figure 4. BOP handling system

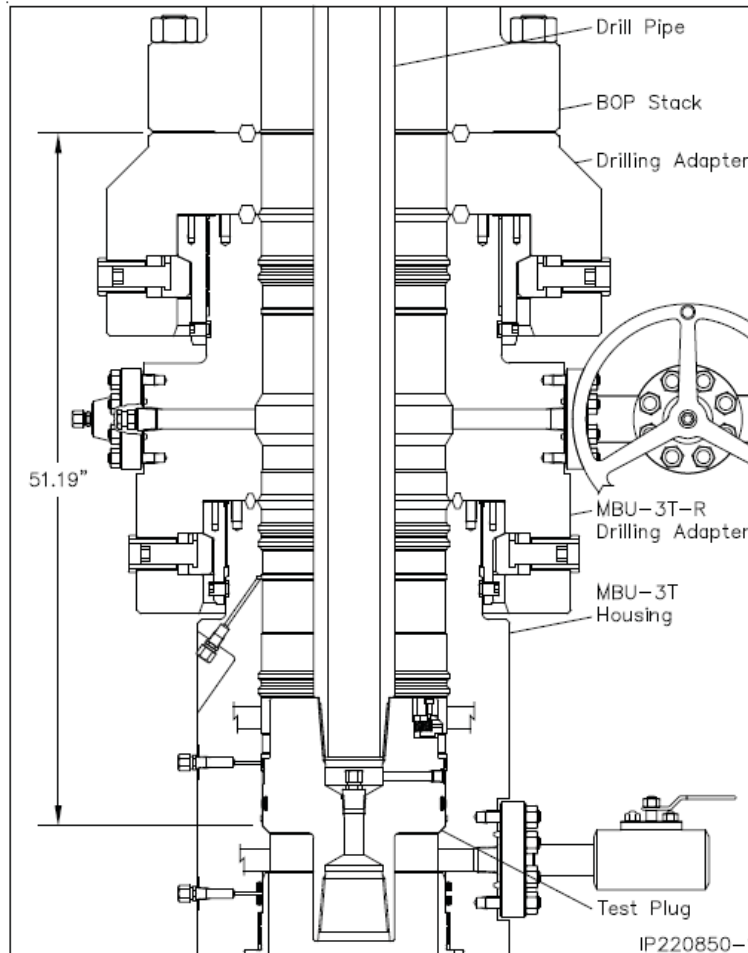

Figure 5. Cactus 5M wellhead with BOP quick connect

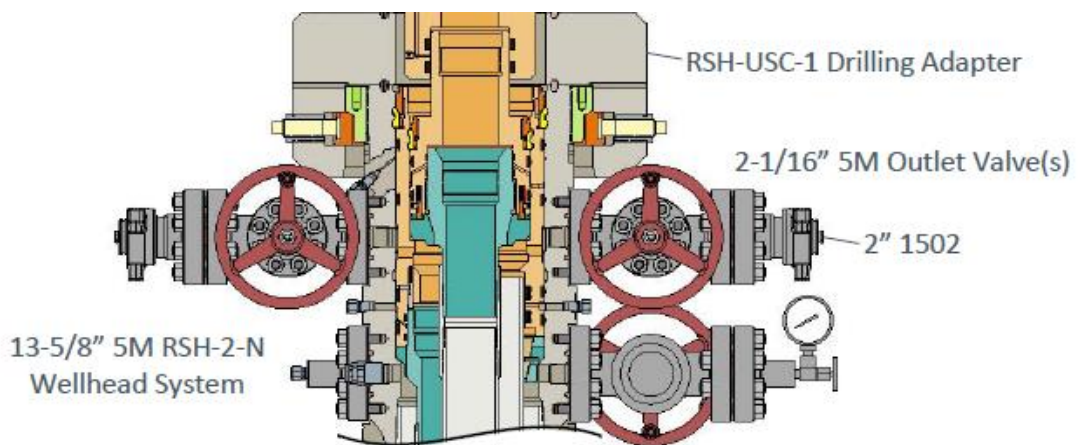

Figure 6. Vault 5M wellhead with BOP quick connect



Mewbourne Oil Co.

Surface & Intermediate Offline Cementing Variance

Mewbourne Oil Company requests a variance to perform offline cementing for surface and intermediate casing strings with the following conditions:

- Offline cementing will not be performed on production casing.
- Offline cementing will not be performed on a hole section with MASP > 5000 psi.
- Offline cementing will not be performed concurrently with offset drilling.

Surface Casing Order of Operations:

1. Run 13 3/8" surface casing as per normal operations (TPGS and float collar).
2. Perform negative pressure test to confirm integrity of float equipment while running casing.
3. Confirm well is static.
4. Make up 13 5/8" wellhead or wellhead landing ring assembly and land on 20" conductor.
5. Fill pipe, circulate casing capacity and confirm float(s) are still holding.
6. Confirm well is static.
7. Back out landing joint and pull to rig floor. Lay down landing joint.
8. Walk rig to next well on pad with cement crew standing by to rig up.
9. Make up offline cement tool with forklift per wellhead manufacturer (Fig. 1 & 2).
10. Make up cement head on top of offline cement tool with forklift.
11. Commence cement operations.
12. If cement circulates, confirm well is static and proceed to step 16.
13. If cement does not circulate, notify the appropriate BLM office, wait a minimum of six hours, and run a temperature survey to determine the top of cement.
14. Use 1" pipe for remedial cement job until the surface casing is cemented to surface.
15. Confirm well is static.
16. Once cement job is complete, the cement head and offline cementing tool are removed. The wellhead technician returns to cellar to install wellhead/valves.
17. Install wellhead capping flange.

Barriers

Before Walk:

- Float(s) in casing
- Kill weight fluid in casing
- Kill weight fluid in annulus



After Walk:

- Float(s) in casing
- Kill weight fluid in casing
- Kill weight fluid in annulus
- Offline cementing tool tested to 5000 psi and cement head
- Capping flange after cementing

20" Surface Casing Order of Operations (4 string area):

1. Run 20" surface casing as per normal operations (TPGS and float collar).
2. Perform negative pressure test to confirm integrity of float equipment while running casing.
3. Fill pipe, circulate casing capacity and confirm float(s) are still holding.
4. Confirm well is static.
5. Back out landing joint and pull to rig floor. Lay down landing joint.
6. Make up cement head.
7. Walk rig to next well on pad with cement crew standing by to rig up.
8. Commence cement operations.
9. If cement circulates, confirm well is static and proceed to step 13.
10. If cement does not circulate, notify the appropriate BLM office, wait a minimum of six hours, and run a temperature survey to determine the top of cement.
11. Use 1" pipe for remedial cement job until the surface casing is cemented to surface.
12. Confirm well is static.
13. Once cement job is complete, remove cement head and install cap.

Barriers

Before Walk:

- Float(s) in casing
- Kill weight fluid in casing
- Kill weight fluid in annulus
- Cement Head

After Walk:

- Float(s) in casing
- Kill weight fluid in casing
- Kill weight fluid in annulus
- Cement head
- Capping flange after cementing



Intermediate Casing Order of Operations:

1. Run casing as per normal operations (float shoe and float collar).
2. Perform negative pressure test to confirm integrity of float equipment while running casing.
3. Confirm well is static (if running SBM).
4. Land casing.
5. Fill pipe, circulate casing capacity and confirm floats are still holding.
6. Confirm well is static.
7. Back out landing joint and pull to rig floor. Lay down landing joint. Install packoff & test.
8. Nipple down BOP.
9. Walk rig to next well on pad with cement crew standing by to rig up.
10. Make up offline cement tool using forklift per wellhead manufacturer (Fig. 3 - 8).
11. Make up cement head on top of offline cement tool.
12. Commence cement operations.
13. If cement circulates, confirm well is static and proceed to step 16.
14. If cement does not circulate (when required), notify the appropriate BLM office, wait a minimum of six hours, and run a temperature survey to determine the top of cement.
15. Pump remedial cement job if required.
16. Confirm well is static.
17. Remove cement head and offline cementing tool.
18. Install wellhead capping flange and test.

Barriers

Before Nipple Down:

- Floats in casing
- Kill weight fluid in casing
- Kill weight fluid in annulus
- Solid body mandrel and/or packoff

After Nipple Down:

- Floats in casing
- Kill weight fluid in casing
- Kill weight fluid in annulus
- Solid body mandrel and/or packoff
- Offline cementing tool tested to 5000 psi and cement head
- Capping flange after cementing



Risks:

- Pressure build up in annulus before cementing
 - Contact BLM if a well control event occurs.
 - Rig up 3rd party pump or rig pumps to pump down casing and kill well.
 - Returns will be taken through the wellhead valves to a choke manifold (Fig 9 & 10).
 - Well could also be killed through the wellhead valves down the annulus.

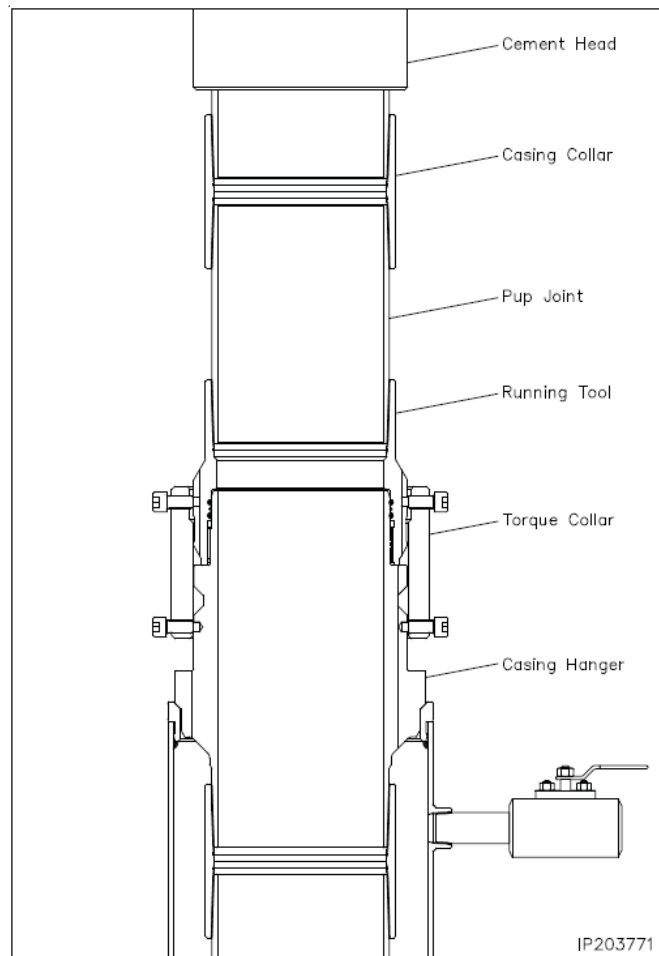

Figure 1. Cactus 13 3/8" 5M offline cementing tool. Pressure rating limited by the lesser of 5M tool rating or the 13 3/8" pup joint and casing.

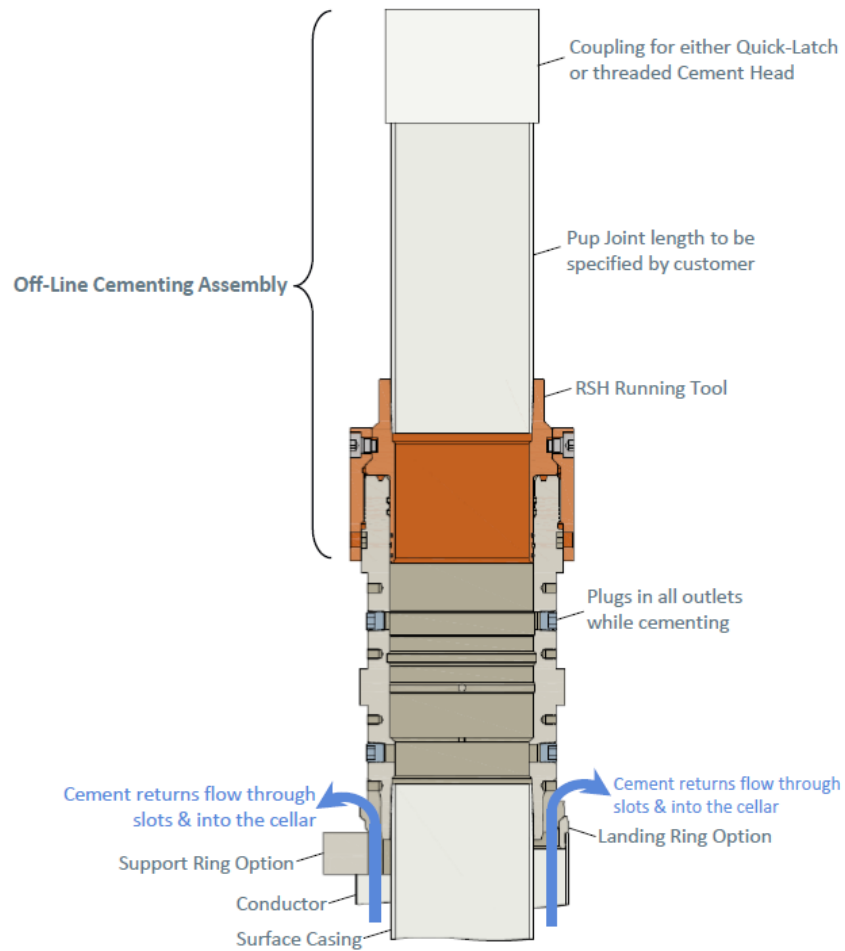

Figure 2. Vault 13 3/8" 5M offline cementing tool. Pressure rating limited by the lesser of 5M tool rating or the 13 3/8" pup joint and casing.

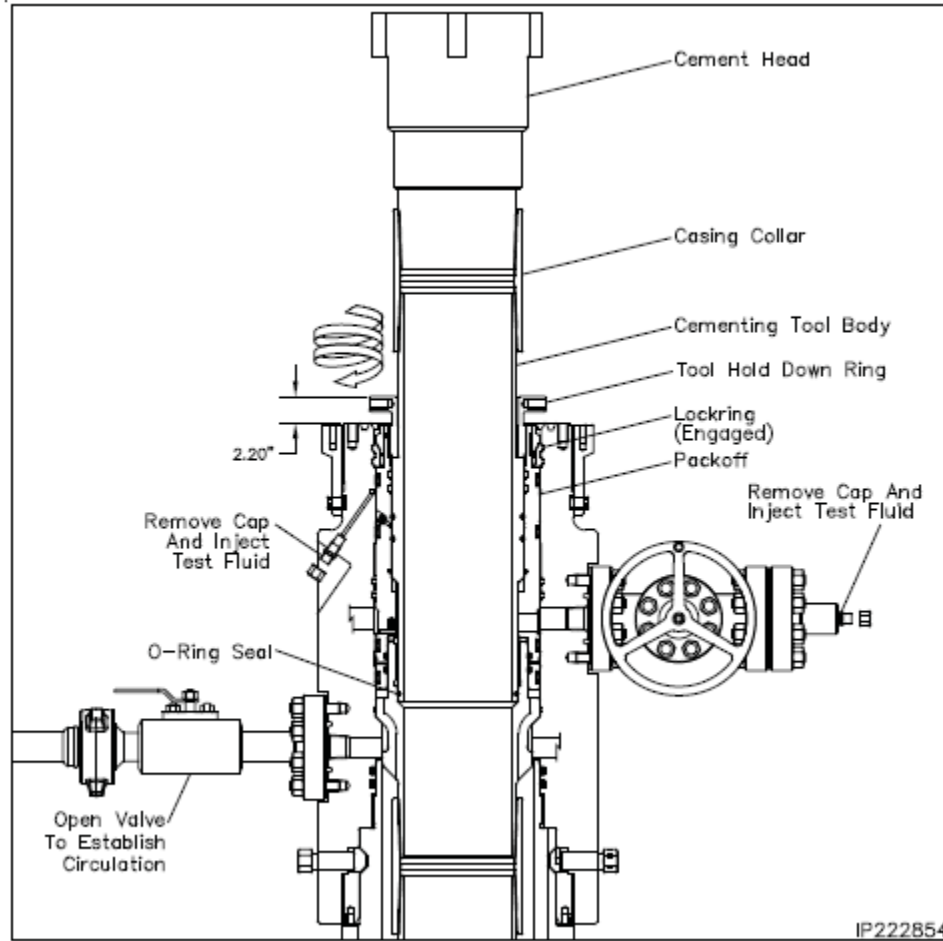

Figure 3. Cactus 9 5/8" 5M offline cementing tool. Pressure rating limited by the lesser of 5M tool rating or the 9 5/8" pup joint and casing.

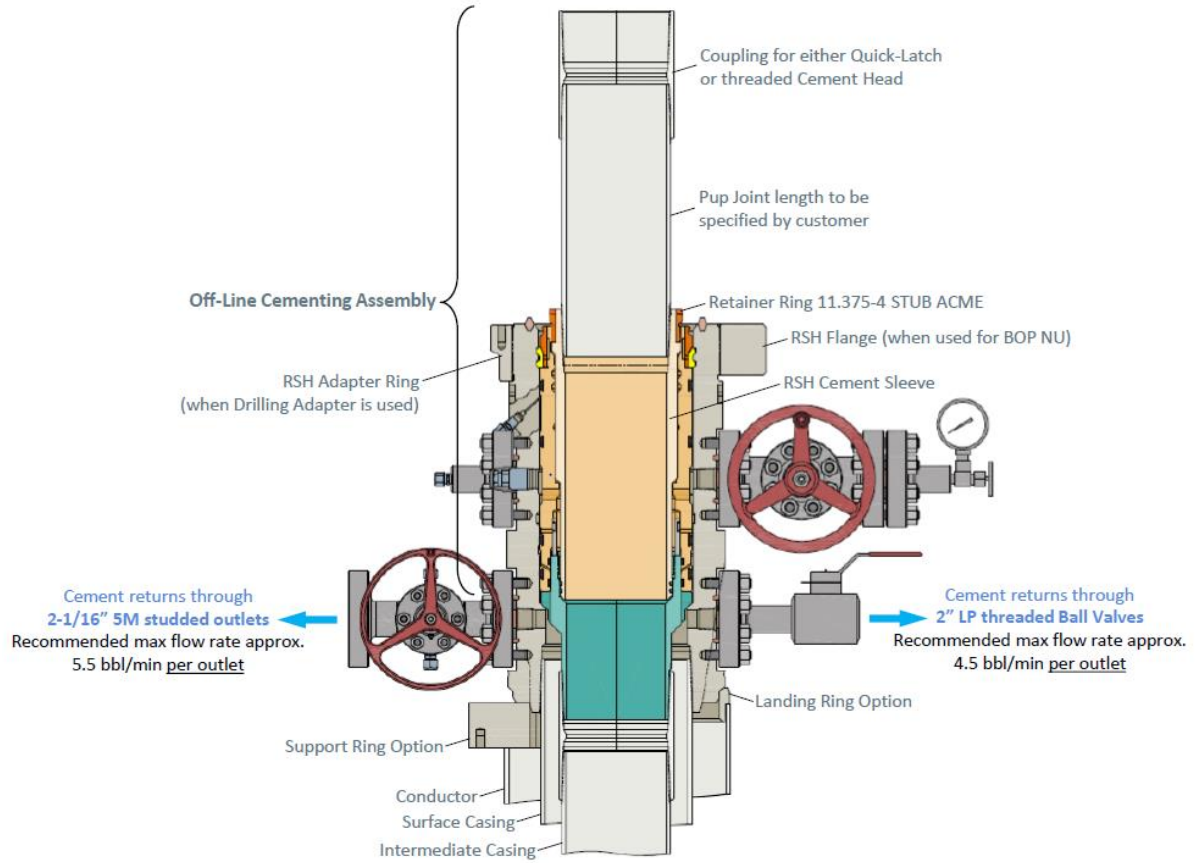

Figure 4. Vault 9 5/8" 5M offline cementing tool. Pressure rating limited by the lesser of 5M tool rating or the 9 5/8" pup joint and casing.

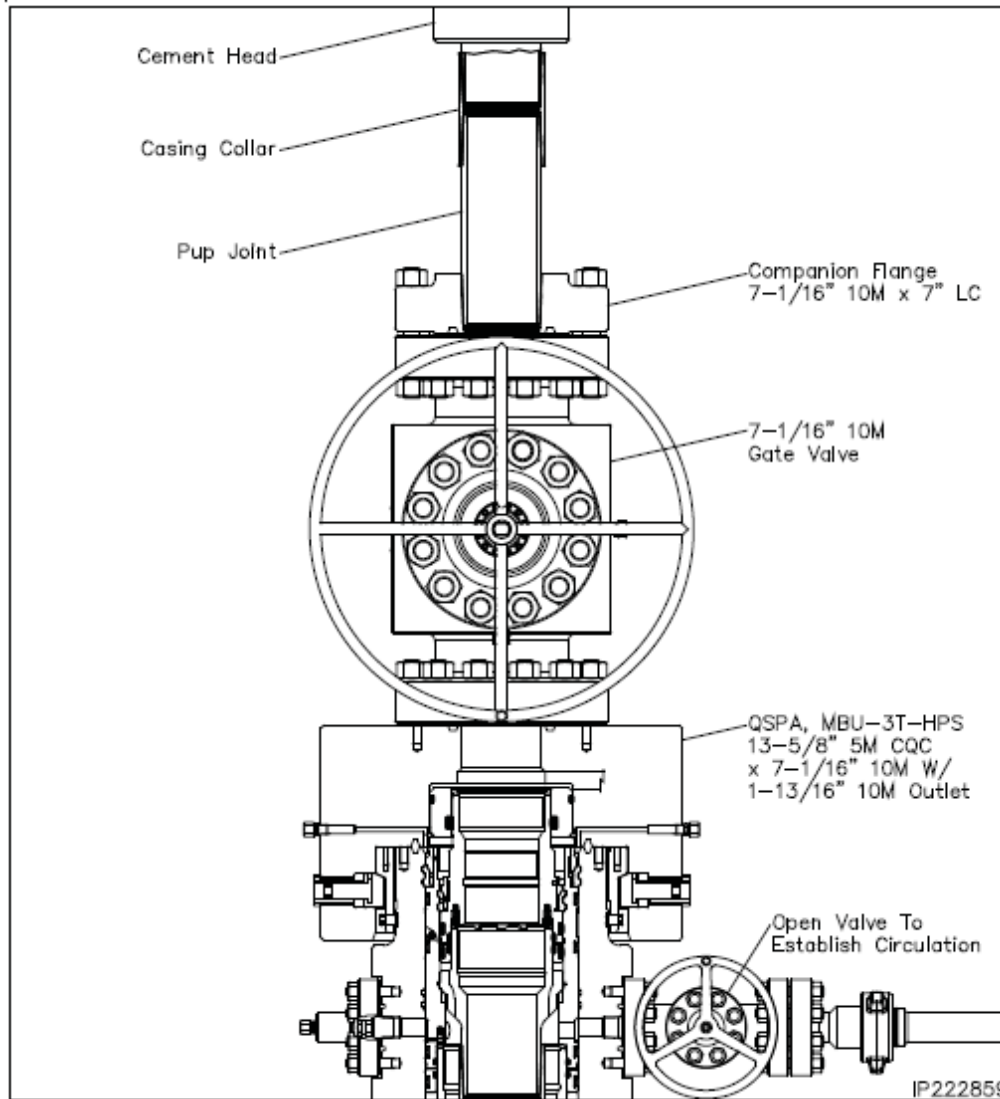

Figure 5. Cactus 7" 5M offline cementing tool. Pressure rating limited by the lesser of 5M tool rating or the 7" pup joint and casing.

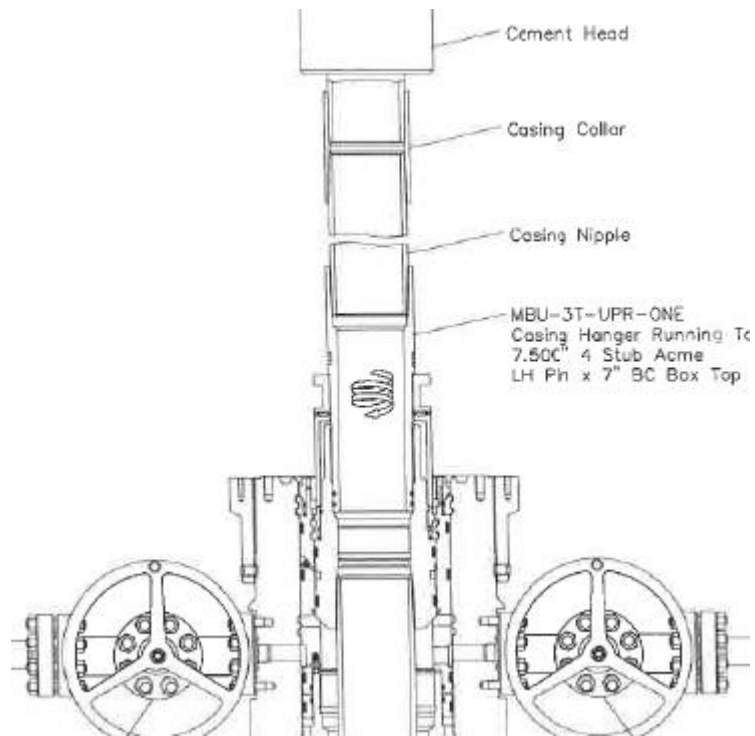

Figure 6. Cactus 7" 5M offline cementing tool. Pressure rating limited by the lesser of 5M tool rating or the 7" pup joint and casing.

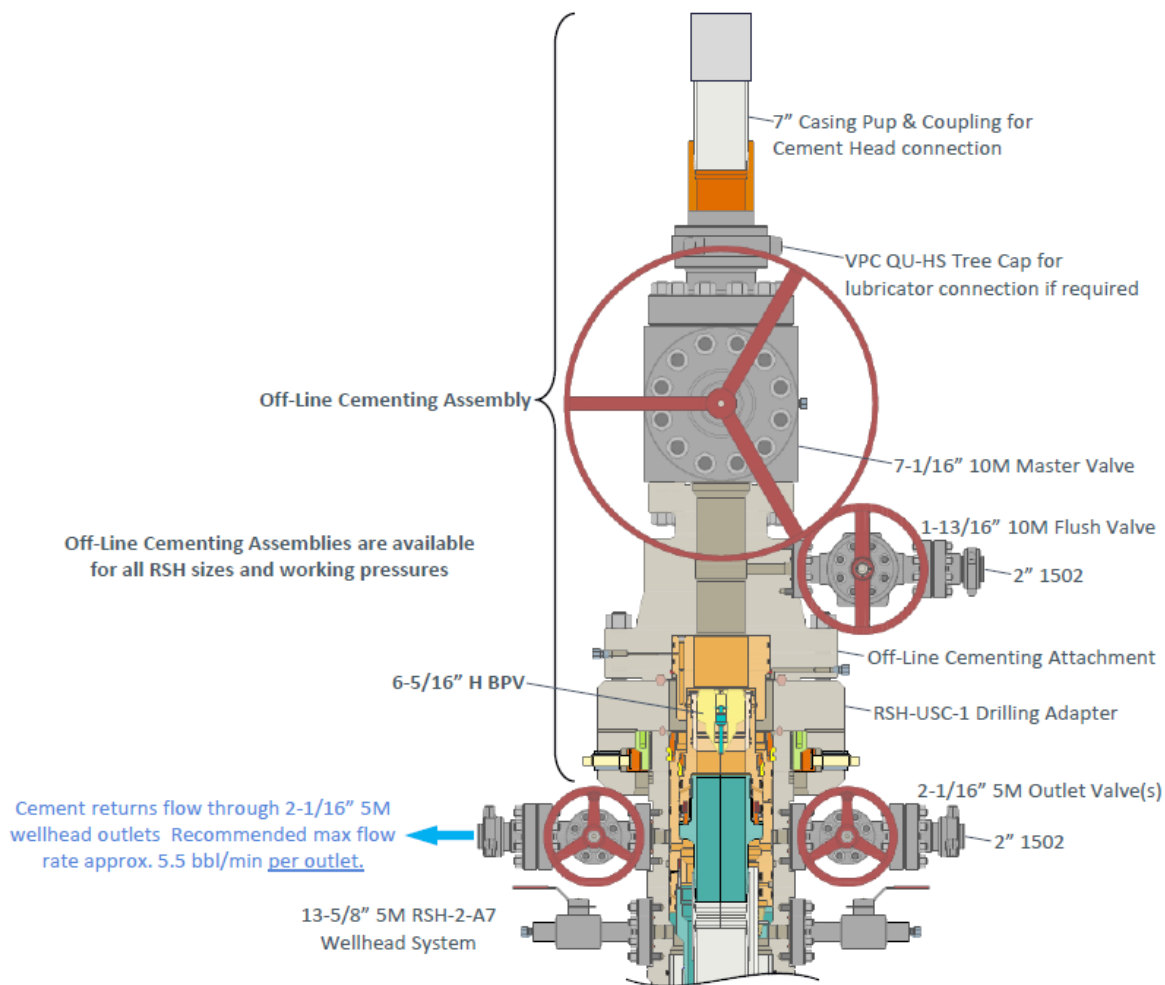

Figure 7. Vault 7" 5M offline cementing tool. Pressure rating limited by the lesser of 5M tool rating or the 7" pup joint and casing.

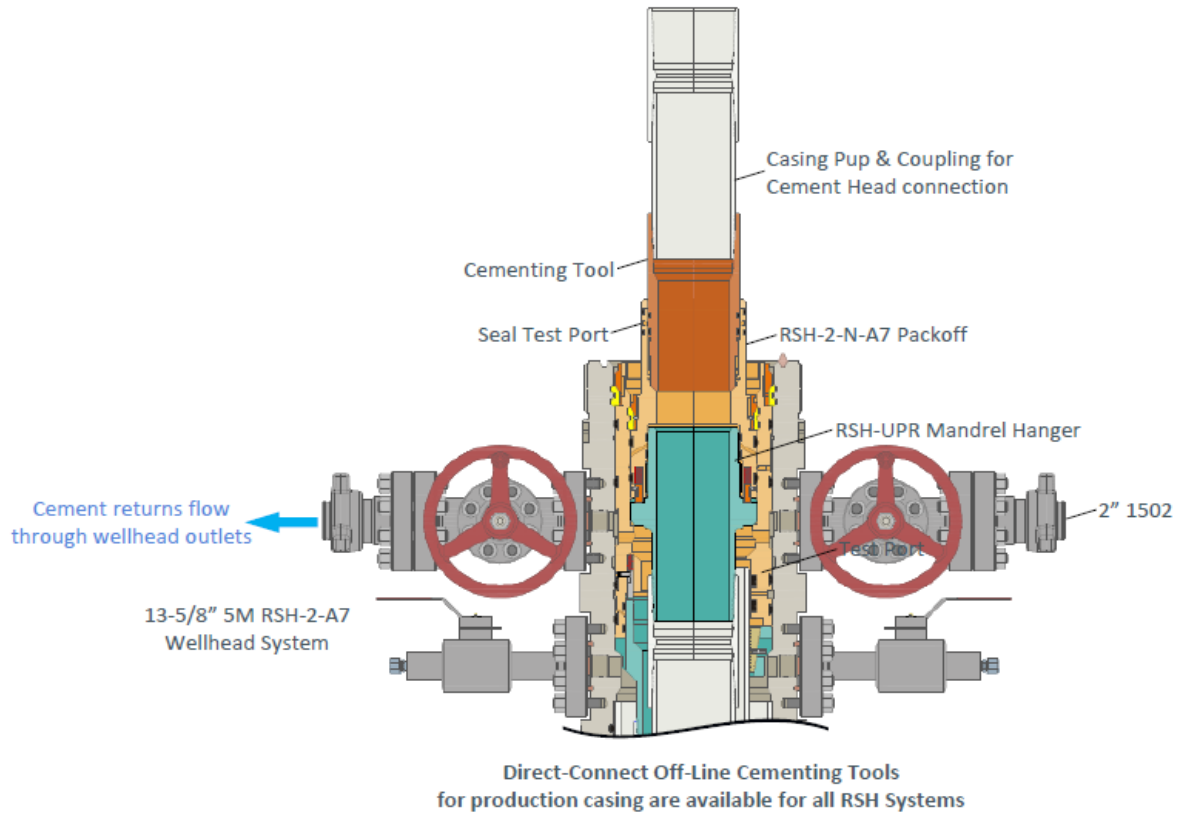

Figure 8. Vault 7" 5M offline cementing tool. Pressure rating limited by the lesser of 5M tool rating or the 7" pup joint and casing.

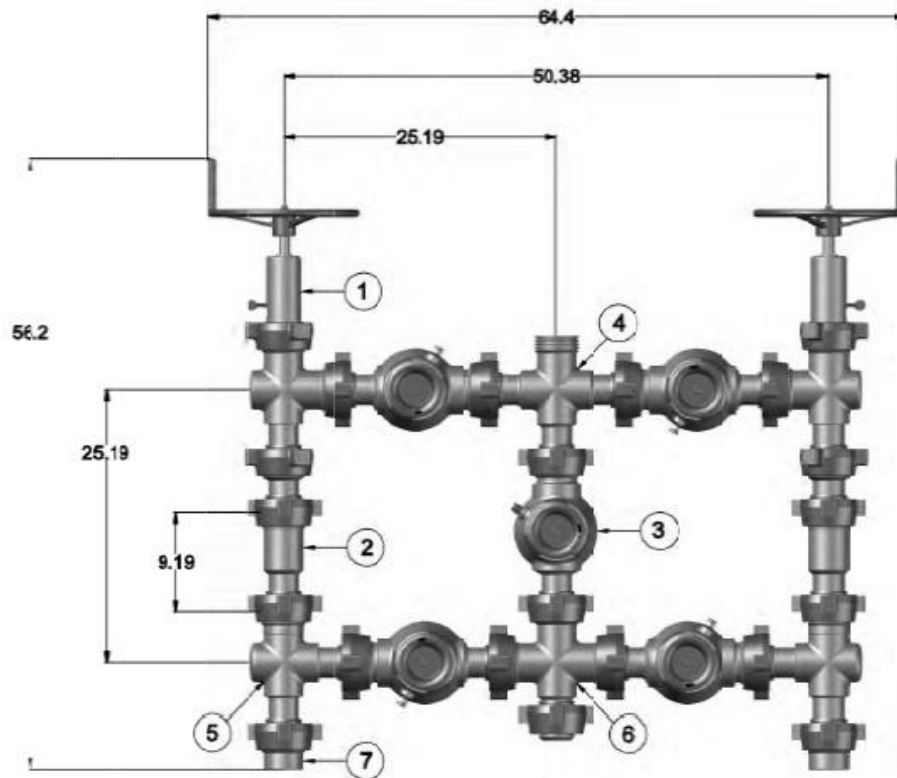

Figure 9. Five valve 15k choke manifold.

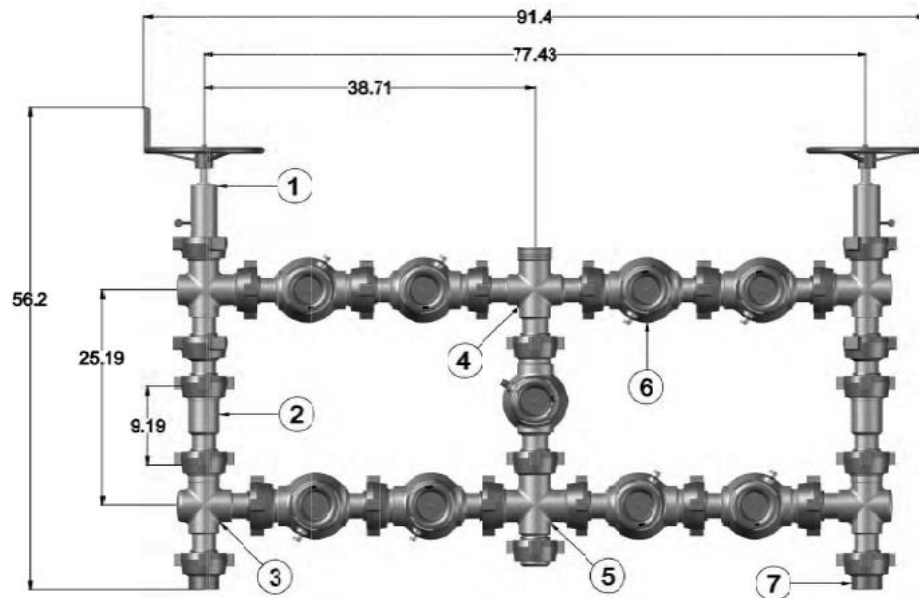

Figure 10. Nine valve 15k choke manifold.

Mewbourne Oil Company Runway 26 30 Fed Com 822H SHL: 1820' FSL & 225' FEL (Sec 27) BHL: 990' FNL & 330' FEL (Sec 30)							
Casing Type	Fluid Type	Hole Size	Casing Description	Top MD	Setting Depth	Sacks Cement	Top of Cement
Surface	Fresh Water	17.5	13.375" 48# H40 STC	0	600	470	0'
Intermediate	Brine	12.25	9.625" 36# J55 LTC	0'	1800	410	0'
Production	Cut-Brine	8.75	7 5/8" 29.7# P110 LTC	0'	9111	630	1600'
Liner	OBM	6.75	5.5" 20# HPP110 Talon	8911'	25496.2	940	8911'

Mewbourne Oil Company

Eddy County, New Mexico NAD 83

Runway 26/30 Fed Com #822H

Sec 27, T22S, R26E

SHL: 1820' FSL & 225' FEL (Sec 27)

BHL: 990' FNL & 330' FEL (Sec 30)

Plan: Design #1

Standard Planning Report

06 February, 2025

Planning Report

Database:	Hobbs	Local Co-ordinate Reference:	Site Runway 26/30 Fed Com #822H
Company:	Mewbourne Oil Company	TVD Reference:	WELL @ 3285.0usft (Original Well Elev)
Project:	Eddy County, New Mexico NAD 83	MD Reference:	WELL @ 3285.0usft (Original Well Elev)
Site:	Runway 26/30 Fed Com #822H	North Reference:	Grid
Well:	Sec 27, T22S, R26E	Survey Calculation Method:	Minimum Curvature
Wellbore:	BHL: 990' FNL & 330' FEL (Sec 30)		
Design:	Design #1		

Project	Eddy County, New Mexico NAD 83		
Map System:	US State Plane 1983	System Datum:	Ground Level
Geo Datum:	North American Datum 1983		
Map Zone:	New Mexico Eastern Zone		

Site	Runway 26/30 Fed Com #822H				
Site Position:		Northing:	495,094.00 usft	Latitude:	32.3610694
From:	Map	Easting:	559,909.10 usft	Longitude:	-104.2731857
Position Uncertainty:	0.0 usft	Slot Radius:	13-3/16 "		

Well	Sec 27, T22S, R26E					
Well Position	+N/-S	0.0 usft	Northing:	495,094.00 usft	Latitude:	32.3610694
	+E/-W	0.0 usft	Easting:	559,909.10 usft	Longitude:	-104.2731857
Position Uncertainty		0.0 usft	Wellhead Elevation:	3,285.0 usft	Ground Level:	3,257.0 usft
Grid Convergence:	0.03 °					

Wellbore	BHL: 990' FNL & 330' FEL (Sec 30)				
Magnetics	Model Name	Sample Date	Declination (°)	Dip Angle (°)	Field Strength (nT)
	IGRF2010	12/31/2014	7.48	60.11	48,244.32971146

Design	Design #1			
Audit Notes:				
Version:	Phase:	PROTOTYPE	Tie On Depth:	0.0
Vertical Section:	Depth From (TVD) (usft)	+N/-S (usft)	+E/-W (usft)	Direction (°)
	0.0	0.0	0.0	80.94

Plan Survey Tool Program	Date	2/6/2025		
Depth From (usft)	Depth To (usft)	Survey (Wellbore)	Tool Name	Remarks
1	0.0	25,496.1	Design #1 (BHL: 990' FNL & 330')	

Planning Report

Database:	Hobbs	Local Co-ordinate Reference:	Site Runway 26/30 Fed Com #822H
Company:	Mewbourne Oil Company	TVD Reference:	WELL @ 3285.0usft (Original Well Elev)
Project:	Eddy County, New Mexico NAD 83	MD Reference:	WELL @ 3285.0usft (Original Well Elev)
Site:	Runway 26/30 Fed Com #822H	North Reference:	Grid
Well:	Sec 27, T22S, R26E	Survey Calculation Method:	Minimum Curvature
Wellbore:	BHL: 990' FNL & 330' FEL (Sec 30)		
Design:	Design #1		

Plan Sections										
Measured Depth (usft)	Inclination (°)	Azimuth (°)	Vertical Depth (usft)	+N/-S (usft)	+E/-W (usft)	Dogleg Rate (°/100usft)	Build Rate (°/100usft)	Turn Rate (°/100usft)	TFO (°)	Target
0.0	0.00	0.00	0.0	0.0	0.0	0.00	0.00	0.00	0.00	
600.0	0.00	0.00	600.0	0.0	0.0	0.00	0.00	0.00	0.00	
1,575.3	19.51	359.45	1,556.6	164.4	-1.6	2.00	2.00	0.00	359.45	
8,135.7	19.51	359.45	7,740.4	2,354.9	-22.8	0.00	0.00	0.00	0.00	
9,111.0	0.00	0.01	8,697.0	2,519.3	-24.4	2.00	-2.00	0.00	180.00	KOP: 990' FNL & 24
9,992.9	88.14	90.10	9,270.0	2,518.4	530.3	9.99	9.99	0.00	90.10	
16,310.3	88.14	90.10	9,475.0	2,507.8	6,844.3	0.00	0.00	0.00	0.00	MLT: 990' FNL & 13
16,388.4	89.65	89.69	9,476.5	2,507.9	6,922.4	2.00	1.93	-0.52	-14.94	BHL: 990' FNL & 33
25,496.2	89.65	89.69	9,532.1	2,556.7	16,029.9	0.00	0.00	0.00	0.00	BHL: 990' FNL & 33

Planning Report

Database:	Hobbs	Local Co-ordinate Reference:	Site Runway 26/30 Fed Com #822H
Company:	Mewbourne Oil Company	TVD Reference:	WELL @ 3285.0usft (Original Well Elev)
Project:	Eddy County, New Mexico NAD 83	MD Reference:	WELL @ 3285.0usft (Original Well Elev)
Site:	Runway 26/30 Fed Com #822H	North Reference:	Grid
Well:	Sec 27, T22S, R26E	Survey Calculation Method:	Minimum Curvature
Wellbore:	BHL: 990' FNL & 330' FEL (Sec 30)		
Design:	Design #1		

Planned Survey										
Measured Depth (usft)	Inclination (°)	Azimuth (°)	Vertical Depth (usft)	+N/-S (usft)	+E/-W (usft)	Vertical Section (usft)	Dogleg Rate (°/100usft)	Build Rate (°/100usft)	Turn Rate (°/100usft)	
0.0	0.00	0.00	0.0	0.0	0.0	0.0	0.00	0.00	0.00	
SHL: 1820' FSL & 225' FEL (Sec 27)										
100.0	0.00	0.00	100.0	0.0	0.0	0.0	0.00	0.00	0.00	
200.0	0.00	0.00	200.0	0.0	0.0	0.0	0.00	0.00	0.00	
300.0	0.00	0.00	300.0	0.0	0.0	0.0	0.00	0.00	0.00	
400.0	0.00	0.00	400.0	0.0	0.0	0.0	0.00	0.00	0.00	
500.0	0.00	0.00	500.0	0.0	0.0	0.0	0.00	0.00	0.00	
600.0	0.00	0.00	600.0	0.0	0.0	0.0	0.00	0.00	0.00	
700.0	2.00	359.45	700.0	1.7	0.0	0.3	2.00	2.00	0.00	
800.0	4.00	359.45	799.8	7.0	-0.1	1.0	2.00	2.00	0.00	
900.0	6.00	359.45	899.5	15.7	-0.2	2.3	2.00	2.00	0.00	
1,000.0	8.00	359.45	998.7	27.9	-0.3	4.1	2.00	2.00	0.00	
1,100.0	10.00	359.45	1,097.5	43.5	-0.4	6.4	2.00	2.00	0.00	
1,200.0	12.00	359.45	1,195.6	62.6	-0.6	9.3	2.00	2.00	0.00	
1,300.0	14.00	359.45	1,293.1	85.1	-0.8	12.6	2.00	2.00	0.00	
1,400.0	16.00	359.45	1,389.6	111.0	-1.1	16.4	2.00	2.00	0.00	
1,500.0	18.00	359.45	1,485.3	140.2	-1.4	20.7	2.00	2.00	0.00	
1,575.3	19.51	359.45	1,556.6	164.4	-1.6	24.3	2.00	2.00	0.00	
1,600.0	19.51	359.45	1,579.9	172.7	-1.7	25.5	0.00	0.00	0.00	
1,700.0	19.51	359.45	1,674.1	206.0	-2.0	30.5	0.00	0.00	0.00	
1,800.0	19.51	359.45	1,768.4	239.4	-2.3	35.4	0.00	0.00	0.00	
1,900.0	19.51	359.45	1,862.6	272.8	-2.6	40.4	0.00	0.00	0.00	
2,000.0	19.51	359.45	1,956.9	306.2	-3.0	45.3	0.00	0.00	0.00	
2,100.0	19.51	359.45	2,051.2	339.6	-3.3	50.2	0.00	0.00	0.00	
2,200.0	19.51	359.45	2,145.4	373.0	-3.6	55.2	0.00	0.00	0.00	
2,300.0	19.51	359.45	2,239.7	406.4	-3.9	60.1	0.00	0.00	0.00	
2,400.0	19.51	359.45	2,333.9	439.8	-4.3	65.1	0.00	0.00	0.00	
2,500.0	19.51	359.45	2,428.2	473.2	-4.6	70.0	0.00	0.00	0.00	
2,600.0	19.51	359.45	2,522.5	506.6	-4.9	74.9	0.00	0.00	0.00	
2,700.0	19.51	359.45	2,616.7	539.9	-5.2	79.9	0.00	0.00	0.00	
2,800.0	19.51	359.45	2,711.0	573.3	-5.6	84.8	0.00	0.00	0.00	
2,900.0	19.51	359.45	2,805.2	606.7	-5.9	89.8	0.00	0.00	0.00	
3,000.0	19.51	359.45	2,899.5	640.1	-6.2	94.7	0.00	0.00	0.00	
3,100.0	19.51	359.45	2,993.8	673.5	-6.5	99.6	0.00	0.00	0.00	
3,200.0	19.51	359.45	3,088.0	706.9	-6.8	104.6	0.00	0.00	0.00	
3,300.0	19.51	359.45	3,182.3	740.3	-7.2	109.5	0.00	0.00	0.00	
3,400.0	19.51	359.45	3,276.5	773.7	-7.5	114.5	0.00	0.00	0.00	
3,500.0	19.51	359.45	3,370.8	807.1	-7.8	119.4	0.00	0.00	0.00	
3,600.0	19.51	359.45	3,465.1	840.4	-8.1	124.3	0.00	0.00	0.00	
3,700.0	19.51	359.45	3,559.3	873.8	-8.5	129.3	0.00	0.00	0.00	
3,800.0	19.51	359.45	3,653.6	907.2	-8.8	134.2	0.00	0.00	0.00	
3,900.0	19.51	359.45	3,747.8	940.6	-9.1	139.2	0.00	0.00	0.00	
4,000.0	19.51	359.45	3,842.1	974.0	-9.4	144.1	0.00	0.00	0.00	
4,100.0	19.51	359.45	3,936.4	1,007.4	-9.8	149.0	0.00	0.00	0.00	
4,200.0	19.51	359.45	4,030.6	1,040.8	-10.1	154.0	0.00	0.00	0.00	
4,300.0	19.51	359.45	4,124.9	1,074.2	-10.4	158.9	0.00	0.00	0.00	
4,400.0	19.51	359.45	4,219.1	1,107.6	-10.7	163.9	0.00	0.00	0.00	
4,500.0	19.51	359.45	4,313.4	1,141.0	-11.1	168.8	0.00	0.00	0.00	
4,600.0	19.51	359.45	4,407.7	1,174.3	-11.4	173.7	0.00	0.00	0.00	
4,700.0	19.51	359.45	4,501.9	1,207.7	-11.7	178.7	0.00	0.00	0.00	
4,800.0	19.51	359.45	4,596.2	1,241.1	-12.0	183.6	0.00	0.00	0.00	
4,900.0	19.51	359.45	4,690.4	1,274.5	-12.3	188.6	0.00	0.00	0.00	
5,000.0	19.51	359.45	4,784.7	1,307.9	-12.7	193.5	0.00	0.00	0.00	
5,100.0	19.51	359.45	4,879.0	1,341.3	-13.0	198.4	0.00	0.00	0.00	

Planning Report

Database:	Hobbs	Local Co-ordinate Reference:	Site Runway 26/30 Fed Com #822H
Company:	Mewbourne Oil Company	TVD Reference:	WELL @ 3285.0usft (Original Well Elev)
Project:	Eddy County, New Mexico NAD 83	MD Reference:	WELL @ 3285.0usft (Original Well Elev)
Site:	Runway 26/30 Fed Com #822H	North Reference:	Grid
Well:	Sec 27, T22S, R26E	Survey Calculation Method:	Minimum Curvature
Wellbore:	BHL: 990' FNL & 330' FEL (Sec 30)		
Design:	Design #1		

Planned Survey									
Measured Depth (usft)	Inclination (°)	Azimuth (°)	Vertical Depth (usft)	+N/-S (usft)	+E/-W (usft)	Vertical Section (usft)	Dogleg Rate (°/100usft)	Build Rate (°/100usft)	Turn Rate (°/100usft)
5,200.0	19.51	359.45	4,973.2	1,374.7	-13.3	203.4	0.00	0.00	0.00
5,300.0	19.51	359.45	5,067.5	1,408.1	-13.6	208.3	0.00	0.00	0.00
5,400.0	19.51	359.45	5,161.8	1,441.5	-14.0	213.2	0.00	0.00	0.00
5,500.0	19.51	359.45	5,256.0	1,474.8	-14.3	218.2	0.00	0.00	0.00
5,600.0	19.51	359.45	5,350.3	1,508.2	-14.6	223.1	0.00	0.00	0.00
5,700.0	19.51	359.45	5,444.5	1,541.6	-14.9	228.1	0.00	0.00	0.00
5,800.0	19.51	359.45	5,538.8	1,575.0	-15.3	233.0	0.00	0.00	0.00
5,900.0	19.51	359.45	5,633.1	1,608.4	-15.6	237.9	0.00	0.00	0.00
6,000.0	19.51	359.45	5,727.3	1,641.8	-15.9	242.9	0.00	0.00	0.00
6,100.0	19.51	359.45	5,821.6	1,675.2	-16.2	247.8	0.00	0.00	0.00
6,200.0	19.51	359.45	5,915.8	1,708.6	-16.5	252.8	0.00	0.00	0.00
6,300.0	19.51	359.45	6,010.1	1,742.0	-16.9	257.7	0.00	0.00	0.00
6,400.0	19.51	359.45	6,104.4	1,775.3	-17.2	262.6	0.00	0.00	0.00
6,500.0	19.51	359.45	6,198.6	1,808.7	-17.5	267.6	0.00	0.00	0.00
6,600.0	19.51	359.45	6,292.9	1,842.1	-17.8	272.5	0.00	0.00	0.00
6,700.0	19.51	359.45	6,387.1	1,875.5	-18.2	277.5	0.00	0.00	0.00
6,800.0	19.51	359.45	6,481.4	1,908.9	-18.5	282.4	0.00	0.00	0.00
6,900.0	19.51	359.45	6,575.7	1,942.3	-18.8	287.3	0.00	0.00	0.00
7,000.0	19.51	359.45	6,669.9	1,975.7	-19.1	292.3	0.00	0.00	0.00
7,100.0	19.51	359.45	6,764.2	2,009.1	-19.5	297.2	0.00	0.00	0.00
7,200.0	19.51	359.45	6,858.4	2,042.5	-19.8	302.2	0.00	0.00	0.00
7,300.0	19.51	359.45	6,952.7	2,075.9	-20.1	307.1	0.00	0.00	0.00
7,400.0	19.51	359.45	7,047.0	2,109.2	-20.4	312.0	0.00	0.00	0.00
7,500.0	19.51	359.45	7,141.2	2,142.6	-20.8	317.0	0.00	0.00	0.00
7,600.0	19.51	359.45	7,235.5	2,176.0	-21.1	321.9	0.00	0.00	0.00
7,700.0	19.51	359.45	7,329.7	2,209.4	-21.4	326.9	0.00	0.00	0.00
7,800.0	19.51	359.45	7,424.0	2,242.8	-21.7	331.8	0.00	0.00	0.00
7,900.0	19.51	359.45	7,518.3	2,276.2	-22.0	336.7	0.00	0.00	0.00
8,000.0	19.51	359.45	7,612.5	2,309.6	-22.4	341.7	0.00	0.00	0.00
8,100.0	19.51	359.45	7,706.8	2,343.0	-22.7	346.6	0.00	0.00	0.00
8,135.7	19.51	359.45	7,740.4	2,354.9	-22.8	348.4	0.00	0.00	0.00
8,200.0	18.22	359.45	7,801.3	2,375.7	-23.0	351.5	2.00	-2.00	0.00
8,300.0	16.22	359.45	7,896.8	2,405.3	-23.3	355.8	2.00	-2.00	0.00
8,400.0	14.22	359.45	7,993.3	2,431.5	-23.5	359.7	2.00	-2.00	0.00
8,500.0	12.22	359.45	8,090.6	2,454.4	-23.8	363.1	2.00	-2.00	0.00
8,600.0	10.22	359.45	8,188.7	2,473.8	-24.0	366.0	2.00	-2.00	0.00
8,700.0	8.22	359.45	8,287.4	2,489.9	-24.1	368.4	2.00	-2.00	0.00
8,800.0	6.22	359.45	8,386.6	2,502.4	-24.2	370.2	2.00	-2.00	0.00
8,900.0	4.22	359.45	8,486.2	2,511.5	-24.3	371.6	2.00	-2.00	0.00
9,000.0	2.22	359.45	8,586.0	2,517.2	-24.4	372.4	2.00	-2.00	0.00
9,100.0	0.22	359.45	8,686.0	2,519.3	-24.4	372.7	2.00	-2.00	0.00
9,111.0	0.00	0.01	8,697.0	2,519.3	-24.4	372.7	2.00	-2.00	0.00
KOP: 990' FNL & 243' FEL (Sec 27)									
9,150.0	3.90	90.10	8,736.0	2,519.3	-23.1	374.0	9.99	9.99	0.00
9,200.0	8.90	90.10	8,785.6	2,519.3	-17.5	379.5	9.99	9.99	0.00
9,250.0	13.89	90.10	8,834.6	2,519.3	-7.6	389.3	9.99	9.99	0.00
9,300.0	18.89	90.10	8,882.6	2,519.2	6.5	403.2	9.99	9.99	0.00
9,350.0	23.89	90.10	8,929.1	2,519.2	24.7	421.2	9.99	9.99	0.00
9,400.0	28.88	90.10	8,973.9	2,519.2	46.9	443.1	9.99	9.99	0.00
9,450.0	33.88	90.10	9,016.6	2,519.1	72.9	468.8	9.99	9.99	0.00
9,500.0	38.88	90.10	9,056.8	2,519.1	102.6	498.1	9.99	9.99	0.00
9,550.0	43.87	90.10	9,094.3	2,519.0	135.6	530.7	9.99	9.99	0.00
9,600.0	48.87	90.10	9,128.8	2,519.0	171.8	566.4	9.99	9.99	0.00

Planning Report

Database:	Hobbs	Local Co-ordinate Reference:	Site Runway 26/30 Fed Com #822H
Company:	Mewbourne Oil Company	TVD Reference:	WELL @ 3285.0usft (Original Well Elev)
Project:	Eddy County, New Mexico NAD 83	MD Reference:	WELL @ 3285.0usft (Original Well Elev)
Site:	Runway 26/30 Fed Com #822H	North Reference:	Grid
Well:	Sec 27, T22S, R26E	Survey Calculation Method:	Minimum Curvature
Wellbore:	BHL: 990' FNL & 330' FEL (Sec 30)		
Design:	Design #1		

Planned Survey									
Measured Depth (usft)	Inclination (°)	Azimuth (°)	Vertical Depth (usft)	+N/-S (usft)	+E/-W (usft)	Vertical Section (usft)	Dogleg Rate (°/100usft)	Build Rate (°/100usft)	Turn Rate (°/100usft)
9,650.0	53.87	90.10	9,160.0	2,518.9	210.9	605.0	9.99	9.99	0.00
9,700.0	58.87	90.10	9,187.7	2,518.8	252.5	646.1	9.99	9.99	0.00
9,750.0	63.86	90.10	9,211.7	2,518.8	296.3	689.4	9.99	9.99	0.00
9,800.0	68.86	90.10	9,231.7	2,518.7	342.1	734.6	9.99	9.99	0.00
9,850.0	73.86	90.10	9,247.7	2,518.6	389.5	781.3	9.99	9.99	0.00
9,900.0	78.85	90.10	9,259.5	2,518.5	438.1	829.3	9.99	9.99	0.00
9,950.0	83.85	90.10	9,267.0	2,518.4	487.5	878.1	9.99	9.99	0.00
9,992.9	88.14	90.10	9,270.0	2,518.4	530.3	920.3	9.99	9.99	0.00
10,000.0	88.14	90.10	9,270.2	2,518.4	537.4	927.3	0.00	0.00	0.00
10,011.1	88.14	90.10	9,270.6	2,518.3	548.5	938.3	0.00	0.00	0.00
FTP/LP: 990' FNL & 330' FWL (Sec 26)									
10,100.0	88.14	90.10	9,273.5	2,518.2	637.3	1,026.0	0.00	0.00	0.00
10,200.0	88.14	90.10	9,276.7	2,518.0	737.3	1,124.7	0.00	0.00	0.00
10,300.0	88.14	90.10	9,280.0	2,517.9	837.2	1,223.3	0.00	0.00	0.00
10,400.0	88.14	90.10	9,283.2	2,517.7	937.2	1,322.0	0.00	0.00	0.00
10,500.0	88.14	90.10	9,286.5	2,517.5	1,037.1	1,420.7	0.00	0.00	0.00
10,600.0	88.14	90.10	9,289.7	2,517.4	1,137.0	1,519.4	0.00	0.00	0.00
10,700.0	88.14	90.10	9,292.9	2,517.2	1,237.0	1,618.0	0.00	0.00	0.00
10,800.0	88.14	90.10	9,296.2	2,517.0	1,336.9	1,716.7	0.00	0.00	0.00
10,900.0	88.14	90.10	9,299.4	2,516.9	1,436.9	1,815.4	0.00	0.00	0.00
11,000.0	88.14	90.10	9,302.7	2,516.7	1,536.8	1,914.0	0.00	0.00	0.00
11,100.0	88.14	90.10	9,305.9	2,516.5	1,636.8	2,012.7	0.00	0.00	0.00
11,200.0	88.14	90.10	9,309.2	2,516.4	1,736.7	2,111.4	0.00	0.00	0.00
11,300.0	88.14	90.10	9,312.4	2,516.2	1,836.7	2,210.1	0.00	0.00	0.00
11,400.0	88.14	90.10	9,315.7	2,516.0	1,936.6	2,308.7	0.00	0.00	0.00
11,500.0	88.14	90.10	9,318.9	2,515.8	2,036.6	2,407.4	0.00	0.00	0.00
11,600.0	88.14	90.10	9,322.1	2,515.7	2,136.5	2,506.1	0.00	0.00	0.00
11,700.0	88.14	90.10	9,325.4	2,515.5	2,236.5	2,604.8	0.00	0.00	0.00
11,800.0	88.14	90.10	9,328.6	2,515.3	2,336.4	2,703.4	0.00	0.00	0.00
11,900.0	88.14	90.10	9,331.9	2,515.2	2,436.4	2,802.1	0.00	0.00	0.00
12,000.0	88.14	90.10	9,335.1	2,515.0	2,536.3	2,900.8	0.00	0.00	0.00
12,100.0	88.14	90.10	9,338.4	2,514.8	2,636.3	2,999.5	0.00	0.00	0.00
12,200.0	88.14	90.10	9,341.6	2,514.7	2,736.2	3,098.1	0.00	0.00	0.00
12,300.0	88.14	90.10	9,344.9	2,514.5	2,836.2	3,196.8	0.00	0.00	0.00
12,400.0	88.14	90.10	9,348.1	2,514.3	2,936.1	3,295.5	0.00	0.00	0.00
12,500.0	88.14	90.10	9,351.4	2,514.2	3,036.0	3,394.1	0.00	0.00	0.00
12,600.0	88.14	90.10	9,354.6	2,514.0	3,136.0	3,492.8	0.00	0.00	0.00
12,700.0	88.14	90.10	9,357.8	2,513.8	3,235.9	3,591.5	0.00	0.00	0.00
12,800.0	88.14	90.10	9,361.1	2,513.7	3,335.9	3,690.2	0.00	0.00	0.00
12,900.0	88.14	90.10	9,364.3	2,513.5	3,435.8	3,788.8	0.00	0.00	0.00
13,000.0	88.14	90.10	9,367.6	2,513.3	3,535.8	3,887.5	0.00	0.00	0.00
13,100.0	88.14	90.10	9,370.8	2,513.2	3,635.7	3,986.2	0.00	0.00	0.00
13,200.0	88.14	90.10	9,374.1	2,513.0	3,735.7	4,084.9	0.00	0.00	0.00
13,300.0	88.14	90.10	9,377.3	2,512.8	3,835.6	4,183.5	0.00	0.00	0.00
13,400.0	88.14	90.10	9,380.6	2,512.7	3,935.6	4,282.2	0.00	0.00	0.00
13,500.0	88.14	90.10	9,383.8	2,512.5	4,035.5	4,380.9	0.00	0.00	0.00
13,600.0	88.14	90.10	9,387.1	2,512.3	4,135.5	4,479.6	0.00	0.00	0.00
13,700.0	88.14	90.10	9,390.3	2,512.2	4,235.4	4,578.2	0.00	0.00	0.00
13,800.0	88.14	90.10	9,393.5	2,512.0	4,335.4	4,676.9	0.00	0.00	0.00
13,900.0	88.14	90.10	9,396.8	2,511.8	4,435.3	4,775.6	0.00	0.00	0.00
14,000.0	88.14	90.10	9,400.0	2,511.7	4,535.3	4,874.2	0.00	0.00	0.00
14,100.0	88.14	90.10	9,403.3	2,511.5	4,635.2	4,972.9	0.00	0.00	0.00
14,200.0	88.14	90.10	9,406.5	2,511.3	4,735.1	5,071.6	0.00	0.00	0.00
14,300.0	88.14	90.10	9,409.8	2,511.2	4,835.1	5,170.3	0.00	0.00	0.00

Planning Report

Database:	Hobbs	Local Co-ordinate Reference:	Site Runway 26/30 Fed Com #822H
Company:	Mewbourne Oil Company	TVD Reference:	WELL @ 3285.0usft (Original Well Elev)
Project:	Eddy County, New Mexico NAD 83	MD Reference:	WELL @ 3285.0usft (Original Well Elev)
Site:	Runway 26/30 Fed Com #822H	North Reference:	Grid
Well:	Sec 27, T22S, R26E	Survey Calculation Method:	Minimum Curvature
Wellbore:	BHL: 990' FNL & 330' FEL (Sec 30)		
Design:	Design #1		

Planned Survey										
Measured Depth (usft)	Inclination (°)	Azimuth (°)	Vertical Depth (usft)	+N/-S (usft)	+E/-W (usft)	Vertical Section (usft)	Dogleg Rate (°/100usft)	Build Rate (°/100usft)	Turn Rate (°/100usft)	
14,400.0	88.14	90.10	9,413.0	2,511.0	4,935.0	5,268.9	0.00	0.00	0.00	
14,500.0	88.14	90.10	9,416.3	2,510.8	5,035.0	5,367.6	0.00	0.00	0.00	
14,600.0	88.14	90.10	9,419.5	2,510.7	5,134.9	5,466.3	0.00	0.00	0.00	
14,700.0	88.14	90.10	9,422.7	2,510.5	5,234.9	5,565.0	0.00	0.00	0.00	
14,800.0	88.14	90.10	9,426.0	2,510.3	5,334.8	5,663.6	0.00	0.00	0.00	
14,900.0	88.14	90.10	9,429.2	2,510.2	5,434.8	5,762.3	0.00	0.00	0.00	
15,000.0	88.14	90.10	9,432.5	2,510.0	5,534.7	5,861.0	0.00	0.00	0.00	
15,100.0	88.14	90.10	9,435.7	2,509.8	5,634.7	5,959.7	0.00	0.00	0.00	
15,200.0	88.14	90.10	9,439.0	2,509.7	5,734.6	6,058.3	0.00	0.00	0.00	
15,300.0	88.14	90.10	9,442.2	2,509.5	5,834.6	6,157.0	0.00	0.00	0.00	
15,400.0	88.14	90.10	9,445.5	2,509.3	5,934.5	6,255.7	0.00	0.00	0.00	
15,500.0	88.14	90.10	9,448.7	2,509.2	6,034.5	6,354.3	0.00	0.00	0.00	
15,600.0	88.14	90.10	9,452.0	2,509.0	6,134.4	6,453.0	0.00	0.00	0.00	
15,700.0	88.14	90.10	9,455.2	2,508.8	6,234.4	6,551.7	0.00	0.00	0.00	
15,800.0	88.14	90.10	9,458.4	2,508.7	6,334.3	6,650.4	0.00	0.00	0.00	
15,900.0	88.14	90.10	9,461.7	2,508.5	6,434.2	6,749.0	0.00	0.00	0.00	
16,000.0	88.14	90.10	9,464.9	2,508.3	6,534.2	6,847.7	0.00	0.00	0.00	
16,100.0	88.14	90.10	9,468.2	2,508.2	6,634.1	6,946.4	0.00	0.00	0.00	
16,200.0	88.14	90.10	9,471.4	2,508.0	6,734.1	7,045.1	0.00	0.00	0.00	
16,300.0	88.14	90.10	9,474.7	2,507.8	6,834.0	7,143.7	0.00	0.00	0.00	
16,310.3	88.14	90.10	9,475.0	2,507.8	6,844.3	7,153.9	0.00	0.00	0.00	
MLT: 990' FNL & 1320' FWL (Sec 25)										
16,388.4	89.65	89.69	9,476.5	2,507.9	6,922.4	7,231.0	2.00	1.93	-0.52	
16,400.0	89.65	89.69	9,476.6	2,508.0	6,934.0	7,242.5	0.00	0.00	0.00	
16,500.0	89.65	89.69	9,477.2	2,508.5	7,034.0	7,341.3	0.00	0.00	0.00	
16,600.0	89.65	89.69	9,477.8	2,509.1	7,134.0	7,440.2	0.00	0.00	0.00	
16,700.0	89.65	89.69	9,478.4	2,509.6	7,234.0	7,539.0	0.00	0.00	0.00	
16,800.0	89.65	89.69	9,479.0	2,510.1	7,334.0	7,637.8	0.00	0.00	0.00	
16,900.0	89.65	89.69	9,479.6	2,510.7	7,434.0	7,736.7	0.00	0.00	0.00	
17,000.0	89.65	89.69	9,480.2	2,511.2	7,534.0	7,835.5	0.00	0.00	0.00	
17,100.0	89.65	89.69	9,480.9	2,511.8	7,634.0	7,934.3	0.00	0.00	0.00	
17,200.0	89.65	89.69	9,481.5	2,512.3	7,734.0	8,033.2	0.00	0.00	0.00	
17,300.0	89.65	89.69	9,482.1	2,512.8	7,834.0	8,132.0	0.00	0.00	0.00	
17,400.0	89.65	89.69	9,482.7	2,513.4	7,934.0	8,230.8	0.00	0.00	0.00	
17,500.0	89.65	89.69	9,483.3	2,513.9	8,034.0	8,329.7	0.00	0.00	0.00	
17,600.0	89.65	89.69	9,483.9	2,514.4	8,134.0	8,428.5	0.00	0.00	0.00	
17,700.0	89.65	89.69	9,484.5	2,515.0	8,234.0	8,527.3	0.00	0.00	0.00	
17,800.0	89.65	89.69	9,485.1	2,515.5	8,334.0	8,626.2	0.00	0.00	0.00	
17,900.0	89.65	89.69	9,485.7	2,516.0	8,434.0	8,725.0	0.00	0.00	0.00	
18,000.0	89.65	89.69	9,486.4	2,516.6	8,534.0	8,823.8	0.00	0.00	0.00	
18,100.0	89.65	89.69	9,487.0	2,517.1	8,634.0	8,922.6	0.00	0.00	0.00	
18,200.0	89.65	89.69	9,487.6	2,517.6	8,734.0	9,021.5	0.00	0.00	0.00	
18,300.0	89.65	89.69	9,488.2	2,518.2	8,834.0	9,120.3	0.00	0.00	0.00	
18,400.0	89.65	89.69	9,488.8	2,518.7	8,933.9	9,219.1	0.00	0.00	0.00	
18,500.0	89.65	89.69	9,489.4	2,519.2	9,033.9	9,318.0	0.00	0.00	0.00	
18,600.0	89.65	89.69	9,490.0	2,519.8	9,133.9	9,416.8	0.00	0.00	0.00	
18,700.0	89.65	89.69	9,490.6	2,520.3	9,233.9	9,515.6	0.00	0.00	0.00	
18,800.0	89.65	89.69	9,491.2	2,520.9	9,333.9	9,614.5	0.00	0.00	0.00	
18,900.0	89.65	89.69	9,491.8	2,521.4	9,433.9	9,713.3	0.00	0.00	0.00	
19,000.0	89.65	89.69	9,492.5	2,521.9	9,533.9	9,812.1	0.00	0.00	0.00	
19,100.0	89.65	89.69	9,493.1	2,522.5	9,633.9	9,911.0	0.00	0.00	0.00	
19,200.0	89.65	89.69	9,493.7	2,523.0	9,733.9	10,009.8	0.00	0.00	0.00	
19,300.0	89.65	89.69	9,494.3	2,523.5	9,833.9	10,108.6	0.00	0.00	0.00	

Planning Report

Database:	Hobbs	Local Co-ordinate Reference:	Site Runway 26/30 Fed Com #822H
Company:	Mewbourne Oil Company	TVD Reference:	WELL @ 3285.0usft (Original Well Elev)
Project:	Eddy County, New Mexico NAD 83	MD Reference:	WELL @ 3285.0usft (Original Well Elev)
Site:	Runway 26/30 Fed Com #822H	North Reference:	Grid
Well:	Sec 27, T22S, R26E	Survey Calculation Method:	Minimum Curvature
Wellbore:	BHL: 990' FNL & 330' FEL (Sec 30)		
Design:	Design #1		

Planned Survey										
Measured Depth (usft)	Inclination (°)	Azimuth (°)	Vertical Depth (usft)	+N/-S (usft)	+E/-W (usft)	Vertical Section (usft)	Dogleg Rate (°/100usft)	Build Rate (°/100usft)	Turn Rate (°/100usft)	
19,400.0	89.65	89.69	9,494.9	2,524.1	9,933.9	10,207.5	0.00	0.00	0.00	
19,500.0	89.65	89.69	9,495.5	2,524.6	10,033.9	10,306.3	0.00	0.00	0.00	
19,600.0	89.65	89.69	9,496.1	2,525.1	10,133.9	10,405.1	0.00	0.00	0.00	
19,700.0	89.65	89.69	9,496.7	2,525.7	10,233.9	10,504.0	0.00	0.00	0.00	
19,800.0	89.65	89.69	9,497.3	2,526.2	10,333.9	10,602.8	0.00	0.00	0.00	
19,900.0	89.65	89.69	9,498.0	2,526.7	10,433.9	10,701.6	0.00	0.00	0.00	
20,000.0	89.65	89.69	9,498.6	2,527.3	10,533.9	10,800.5	0.00	0.00	0.00	
20,100.0	89.65	89.69	9,499.2	2,527.8	10,633.9	10,899.3	0.00	0.00	0.00	
20,200.0	89.65	89.69	9,499.8	2,528.3	10,733.9	10,998.1	0.00	0.00	0.00	
20,300.0	89.65	89.69	9,500.4	2,528.9	10,833.9	11,097.0	0.00	0.00	0.00	
20,400.0	89.65	89.69	9,501.0	2,529.4	10,933.9	11,195.8	0.00	0.00	0.00	
20,500.0	89.65	89.69	9,501.6	2,530.0	11,033.9	11,294.6	0.00	0.00	0.00	
20,600.0	89.65	89.69	9,502.2	2,530.5	11,133.9	11,393.5	0.00	0.00	0.00	
20,700.0	89.65	89.69	9,502.8	2,531.0	11,233.9	11,492.3	0.00	0.00	0.00	
20,800.0	89.65	89.69	9,503.5	2,531.6	11,333.9	11,591.1	0.00	0.00	0.00	
20,900.0	89.65	89.69	9,504.1	2,532.1	11,433.9	11,690.0	0.00	0.00	0.00	
21,000.0	89.65	89.69	9,504.7	2,532.6	11,533.9	11,788.8	0.00	0.00	0.00	
21,100.0	89.65	89.69	9,505.3	2,533.2	11,633.9	11,887.6	0.00	0.00	0.00	
21,200.0	89.65	89.69	9,505.9	2,533.7	11,733.9	11,986.5	0.00	0.00	0.00	
21,300.0	89.65	89.69	9,506.5	2,534.2	11,833.9	12,085.3	0.00	0.00	0.00	
21,400.0	89.65	89.69	9,507.1	2,534.8	11,933.9	12,184.1	0.00	0.00	0.00	
21,500.0	89.65	89.69	9,507.7	2,535.3	12,033.8	12,283.0	0.00	0.00	0.00	
21,600.0	89.65	89.69	9,508.3	2,535.8	12,133.8	12,381.8	0.00	0.00	0.00	
21,700.0	89.65	89.69	9,509.0	2,536.4	12,233.8	12,480.6	0.00	0.00	0.00	
21,800.0	89.65	89.69	9,509.6	2,536.9	12,333.8	12,579.5	0.00	0.00	0.00	
21,900.0	89.65	89.69	9,510.2	2,537.4	12,433.8	12,678.3	0.00	0.00	0.00	
22,000.0	89.65	89.69	9,510.8	2,538.0	12,533.8	12,777.1	0.00	0.00	0.00	
22,100.0	89.65	89.69	9,511.4	2,538.5	12,633.8	12,876.0	0.00	0.00	0.00	
22,200.0	89.65	89.69	9,512.0	2,539.1	12,733.8	12,974.8	0.00	0.00	0.00	
22,300.0	89.65	89.69	9,512.6	2,539.6	12,833.8	13,073.6	0.00	0.00	0.00	
22,400.0	89.65	89.69	9,513.2	2,540.1	12,933.8	13,172.5	0.00	0.00	0.00	
22,500.0	89.65	89.69	9,513.8	2,540.7	13,033.8	13,271.3	0.00	0.00	0.00	
22,600.0	89.65	89.69	9,514.5	2,541.2	13,133.8	13,370.1	0.00	0.00	0.00	
22,700.0	89.65	89.69	9,515.1	2,541.7	13,233.8	13,469.0	0.00	0.00	0.00	
22,800.0	89.65	89.69	9,515.7	2,542.3	13,333.8	13,567.8	0.00	0.00	0.00	
22,900.0	89.65	89.69	9,516.3	2,542.8	13,433.8	13,666.6	0.00	0.00	0.00	
23,000.0	89.65	89.69	9,516.9	2,543.3	13,533.8	13,765.5	0.00	0.00	0.00	
23,100.0	89.65	89.69	9,517.5	2,543.9	13,633.8	13,864.3	0.00	0.00	0.00	
23,200.0	89.65	89.69	9,518.1	2,544.4	13,733.8	13,963.1	0.00	0.00	0.00	
23,300.0	89.65	89.69	9,518.7	2,544.9	13,833.8	14,062.0	0.00	0.00	0.00	
23,400.0	89.65	89.69	9,519.3	2,545.5	13,933.8	14,160.8	0.00	0.00	0.00	
23,500.0	89.65	89.69	9,519.9	2,546.0	14,033.8	14,259.6	0.00	0.00	0.00	
23,600.0	89.65	89.69	9,520.6	2,546.5	14,133.8	14,358.5	0.00	0.00	0.00	
23,700.0	89.65	89.69	9,521.2	2,547.1	14,233.8	14,457.3	0.00	0.00	0.00	
23,800.0	89.65	89.69	9,521.8	2,547.6	14,333.8	14,556.1	0.00	0.00	0.00	
23,900.0	89.65	89.69	9,522.4	2,548.2	14,433.8	14,655.0	0.00	0.00	0.00	
24,000.0	89.65	89.69	9,523.0	2,548.7	14,533.8	14,753.8	0.00	0.00	0.00	
24,100.0	89.65	89.69	9,523.6	2,549.2	14,633.8	14,852.6	0.00	0.00	0.00	
24,200.0	89.65	89.69	9,524.2	2,549.8	14,733.8	14,951.5	0.00	0.00	0.00	
24,300.0	89.65	89.69	9,524.8	2,550.3	14,833.8	15,050.3	0.00	0.00	0.00	
24,400.0	89.65	89.69	9,525.4	2,550.8	14,933.8	15,149.1	0.00	0.00	0.00	
24,500.0	89.65	89.69	9,526.1	2,551.4	15,033.7	15,248.0	0.00	0.00	0.00	
24,600.0	89.65	89.69	9,526.7	2,551.9	15,133.7	15,346.8	0.00	0.00	0.00	
24,700.0	89.65	89.69	9,527.3	2,552.4	15,233.7	15,445.6	0.00	0.00	0.00	

Planning Report

Database:	Hobbs	Local Co-ordinate Reference:	Site Runway 26/30 Fed Com #822H
Company:	Mewbourne Oil Company	TVD Reference:	WELL @ 3285.0usft (Original Well Elev)
Project:	Eddy County, New Mexico NAD 83	MD Reference:	WELL @ 3285.0usft (Original Well Elev)
Site:	Runway 26/30 Fed Com #822H	North Reference:	Grid
Well:	Sec 27, T22S, R26E	Survey Calculation Method:	Minimum Curvature
Wellbore:	BHL: 990' FNL & 330' FEL (Sec 30)		
Design:	Design #1		

Planned Survey										
Measured Depth (usft)	Inclination (°)	Azimuth (°)	Vertical Depth (usft)	+N/-S (usft)	+E/-W (usft)	Vertical Section (usft)	Dogleg Rate (°/100usft)	Build Rate (°/100usft)	Turn Rate (°/100usft)	
24,800.0	89.65	89.69	9,527.9	2,553.0	15,333.7	15,544.5	0.00	0.00	0.00	
24,900.0	89.65	89.69	9,528.5	2,553.5	15,433.7	15,643.3	0.00	0.00	0.00	
25,000.0	89.65	89.69	9,529.1	2,554.0	15,533.7	15,742.1	0.00	0.00	0.00	
25,100.0	89.65	89.69	9,529.7	2,554.6	15,633.7	15,841.0	0.00	0.00	0.00	
25,200.0	89.65	89.69	9,530.3	2,555.1	15,733.7	15,939.8	0.00	0.00	0.00	
25,300.0	89.65	89.69	9,530.9	2,555.6	15,833.7	16,038.6	0.00	0.00	0.00	
25,400.0	89.65	89.69	9,531.6	2,556.2	15,933.7	16,137.4	0.00	0.00	0.00	
25,496.2	89.65	89.69	9,532.1	2,556.7	16,029.9	16,232.5	0.00	0.00	0.00	
BHL: 990' FNL & 330' FEL (Sec 30)										

Design Targets										
Target Name	Dip Angle (°)	Dip Dir. (°)	TVD (usft)	+N/-S (usft)	+E/-W (usft)	Northing (usft)	Easting (usft)	Latitude	Longitude	
SHL: 1820' FSL & 225' - plan hits target center - Point	0.00	0.00	0.0	0.0	0.0	495,094.00	559,909.10	32.3610694	-104.2731857	
KOP: 990' FNL & 243' - plan hits target center - Point	0.00	0.01	8,697.0	2,519.3	-24.4	497,613.30	559,884.70	32.3679946	-104.2732602	
FTP/LP: 990' FNL & 3 - plan hits target center - Point	0.00	0.00	9,270.6	2,518.3	548.5	497,612.34	560,457.60	32.3679910	-104.2714046	
MLT: 990' FNL & 1320 - plan hits target center - Point	0.00	0.00	9,475.0	2,507.8	6,844.3	497,601.80	566,753.40	32.3679504	-104.2510130	
BHL: 990' FNL & 330' - plan misses target center by 0.1usft at 25496.2usft MD (9532.1 TVD, 2556.7 N, 16029.9 E) - Point	0.00	0.00	9,532.0	2,556.7	16,029.9	497,650.70	575,939.00	32.3680619	-104.2212613	

State of New Mexico
Energy, Minerals and Natural Resources Department

Submit Electronically
Via E-permitting

Oil Conservation Division
1220 South St. Francis Dr.
Santa Fe, NM 87505

NATURAL GAS MANAGEMENT PLAN

This Natural Gas Management Plan must be submitted with each Application for Permit to Drill (APD) for a new or recompleted well.

Section 1 – Plan Description

Effective May 25, 2021

I. Operator: Mewbourne Oil Co. **OGRID:** 14744 **Date:** 2/11/25

II. Type: Original Amendment due to 19.15.27.9.D(6)(a) NMAC 19.15.27.9.D(6)(b) NMAC Other.

If Other, please describe: _____

III. Well(s): Provide the following information for each new or recompleted well or set of wells proposed to be drilled or proposed to be recompleted from a single well pad or connected to a central delivery point.

Well Name	API	ULSTR	Footages	Anticipated Oil BBL/D	Anticipated Gas MCF/D	Anticipated Produced Water BBL/D
RUNWAY 26/30 FED COM 822H		I 27 22S 26E	1820' FSL x 245' FEL	1000	10000	5000
				Y1-500 Y2-300 Y3-200	Y1-5000 Y2-3000 Y3-2000	Y1-2500 Y2-1500 Y3-1000

IV. Central Delivery Point Name: RUNWAY 26/30 FED COM 822H [See 19.15.27.9(D)(1) NMAC]

V. Anticipated Schedule: Provide the following information for each new or recompleted well or set of wells proposed to be drilled or proposed to be recompleted from a single well pad or connected to a central delivery point.

Well Name	API	Spud Date	TD Reached Date	Completion Commencement Date	Initial Flow Back Date	First Production Date
RUNWAY 26/30 FED COM 822H		3/11/25	4/11/25	5/11/25	5/26/25	5/31/25

VI. Separation Equipment: Attach a complete description of how Operator will size separation equipment to optimize gas capture.

VII. Operational Practices: Attach a complete description of the actions Operator will take to comply with the requirements of Subsection A through F of 19.15.27.8 NMAC.

VIII. Best Management Practices: Attach a complete description of Operator's best management practices to minimize venting during active and planned maintenance.

Section 2 – Enhanced Plan
EFFECTIVE APRIL 1, 2022

Beginning April 1, 2022, an operator that is not in compliance with its statewide natural gas capture requirement for the applicable reporting area must complete this section.

Operator certifies that it is not required to complete this section because Operator is in compliance with its statewide natural gas capture requirement for the applicable reporting area.

IX. Anticipated Natural Gas Production:

Well	API	Anticipated Average Natural Gas Rate MCF/D	Anticipated Volume of Natural Gas for the First Year MCF

X. Natural Gas Gathering System (NGGS):

Operator	System	ULSTR of Tie-in	Anticipated Gathering Start Date	Available Maximum Daily Capacity of System Segment Tie-in

XI. Map. Attach an accurate and legible map depicting the location of the well(s), the anticipated pipeline route(s) connecting the production operations to the existing or planned interconnect of the natural gas gathering system(s), and the maximum daily capacity of the segment or portion of the natural gas gathering system(s) to which the well(s) will be connected.

XII. Line Capacity. The natural gas gathering system will will not have capacity to gather 100% of the anticipated natural gas production volume from the well prior to the date of first production.

XIII. Line Pressure. Operator does does not anticipate that its existing well(s) connected to the same segment, or portion, of the natural gas gathering system(s) described above will continue to meet anticipated increases in line pressure caused by the new well(s).

Attach Operator’s plan to manage production in response to the increased line pressure.

XIV. Confidentiality: Operator asserts confidentiality pursuant to Section 71-2-8 NMSA 1978 for the information provided in Section 2 as provided in Paragraph (2) of Subsection D of 19.15.27.9 NMAC, and attaches a full description of the specific information for which confidentiality is asserted and the basis for such assertion.

Section 3 - Certifications

Effective May 25, 2021

Operator certifies that, after reasonable inquiry and based on the available information at the time of submittal:

Operator will be able to connect the well(s) to a natural gas gathering system in the general area with sufficient capacity to transport one hundred percent of the anticipated volume of natural gas produced from the well(s) commencing on the date of first production, taking into account the current and anticipated volumes of produced natural gas from other wells connected to the pipeline gathering system; or

Operator will not be able to connect to a natural gas gathering system in the general area with sufficient capacity to transport one hundred percent of the anticipated volume of natural gas produced from the well(s) commencing on the date of first production, taking into account the current and anticipated volumes of produced natural gas from other wells connected to the pipeline gathering system.

If Operator checks this box, Operator will select one of the following:

Well Shut-In. Operator will shut-in and not produce the well until it submits the certification required by Paragraph (4) of Subsection D of 19.15.27.9 NMAC; or

Venting and Flaring Plan. Operator has attached a venting and flaring plan that evaluates and selects one or more of the potential alternative beneficial uses for the natural gas until a natural gas gathering system is available, including:

- (a) power generation on lease;
- (b) power generation for grid;
- (c) compression on lease;
- (d) liquids removal on lease;
- (e) reinjection for underground storage;
- (f) reinjection for temporary storage;
- (g) reinjection for enhanced oil recovery;
- (h) fuel cell production; and
- (i) other alternative beneficial uses approved by the division.

Section 4 - Notices

1. If, at any time after Operator submits this Natural Gas Management Plan and before the well is spud:

(a) Operator becomes aware that the natural gas gathering system it planned to connect the well(s) to has become unavailable or will not have capacity to transport one hundred percent of the production from the well(s), no later than 20 days after becoming aware of such information, Operator shall submit for OCD's approval a new or revised venting and flaring plan containing the information specified in Paragraph (5) of Subsection D of 19.15.27.9 NMAC; or

(b) Operator becomes aware that it has, cumulatively for the year, become out of compliance with its baseline natural gas capture rate or natural gas capture requirement, no later than 20 days after becoming aware of such information, Operator shall submit for OCD's approval a new or revised Natural Gas Management Plan for each well it plans to spud during the next 90 days containing the information specified in Paragraph (2) of Subsection D of 19.15.27.9 NMAC, and shall file an update for each Natural Gas Management Plan until Operator is back in compliance with its baseline natural gas capture rate or natural gas capture requirement.

2. OCD may deny or conditionally approve an APD if Operator does not make a certification, fails to submit an adequate venting and flaring plan which includes alternative beneficial uses for the anticipated volume of natural gas produced, or if OCD determines that Operator will not have adequate natural gas takeaway capacity at the time a well will be spud.

Page 8

I certify that, after reasonable inquiry, the statements in and attached to this Natural Gas Management Plan are true and correct to the best of my knowledge and acknowledge that a false statement may be subject to civil and criminal penalties under the Oil and Gas Act.

Signature:	<i>Bradley Bishop</i>
Printed Name:	BRADLEY BISHOP
Title:	REGULATORY MANAGER
E-mail Address:	BBISHOP@MEWBOURNE.COM
Date:	2/11/25
Phone:	575-393-5905
OIL CONSERVATION DIVISION (Only applicable when submitted as a standalone form)	
Approved By:	
Title:	
Approval Date:	
Conditions of Approval:	

Mewbourne Oil Company

Natural Gas Management Plan – Attachment

- VI. Separation equipment will be sized by construction engineering staff based on stated manufacturer daily throughput capacities and anticipated daily production rates to ensure adequate capacity. Closed vent system piping, compression needs, and VRUs will be sized utilizing ProMax modelling software to ensure adequate capacity for anticipated production volumes and conditions.
- VII. Mewbourne Oil Company (MOC) will take following actions to comply with the regulations listed in 19.15.27.8 :
- A. MOC will maximize the recovery of natural gas by minimizing the waste, as defined by 19.15.2 NMAC, of natural gas through venting and flaring. MOC will ensure that well(s) will be connected to a natural gas gathering system with sufficient capacity to transport natural gas. If there is no adequate takeaway for the gas, well(s) will be shut in until the natural gas gathering system is available.
 - B. All drilling operations will be equipped with a rig flare located at least 100 ft from the nearest surface hole. Rig flare will be utilized to combust any natural gas that is brought to surface during normal drilling operations. In the case of emergency venting or flaring the volumes will be estimated and reported appropriately.
 - C. During completion operations any natural gas brought to surface will be flared. Immediately following the finish of completion operations, all well flow will be directed to permanent separation equipment. Produced natural gas from separation equipment will be sent to sales. It is not anticipated that gas will not meet pipeline standards. However, if natural gas does not meet gathering pipeline quality specifications, MOC will flare the natural gas for 60 days or until the natural gas meets the pipeline quality specifications, whichever is sooner. MOC will ensure that the flare is sized properly and is equipped with automatic igniter or continuous pilot. The gas sample will analyzed twice per week and the gas will be routed into a gathering system as soon as pipeline specifications are met.
 - D. Natural gas will not be flared with the exceptions and provisions listed in the 19.15.27.8 D.(1) through (4). If there is no adequate takeaway for the separator gas, well(s) will be shut in until the natural gas gathering system is available with exception of emergency or malfunction situations. Venting and/or flaring volumes will be estimated and reported appropriately.
 - E. MOC will comply with the performance standards requirements and provisions listed in 19.15.27.8 E.(1) through (8). All equipment will be designed and sized to handle maximum anticipated pressures and throughputs in order to minimize the waste. Production storage tanks constructed after May 25, 2021 will be equipped with automatic gauging system. Flares constructed after May 25, 2021 will be equipped with automatic igniter or continuous pilot. Flares will be located at least 100' from the well and storage tanks unless otherwise approved by the division. MOC will conduct AVO inspections as described in 19.15.27.8 E (5) (a) with frequencies specified in 19.15.27.8 E (5) (b) and (c). All emergencies will be resolved as quickly and safely as feasible to minimize waste.
 - F. The volume of natural gas that is vented or flared as the result of malfunction or emergency during drilling and completions operations will be estimated. The volume of natural gas that is vented, flared or beneficially used during production operations, will be measured or estimated. MOC will install equipment to measure

the volume of natural gas flared from existing process piping or a flowline piped from equipment such as high pressure separators, heater treaters, or vapor recovery units associated with a well or facility associated with a well authorized by an APD issued after May 25, 2021 that has an average daily production greater than 60 Mcf/day. If metering is not practicable due to circumstances such as low flow rate or low pressure venting and flaring, MOC will estimate the volume of vented or flared natural gas. Measuring equipment will conform to industry standards and will not be designed or equipped with a manifold that allows the diversion of natural gas around the metering element except for the sole purpose of inspecting and servicing the measurement equipment.

- VIII. For maintenance activities involving production equipment and compression, venting will be limited to the depressurization of the subject equipment to ensure safe working conditions. For maintenance of production and compression equipment the associated producing wells will be shut in to eliminate venting. For maintenance of VRUs all gas normally routed to the VRU will be routed to flare to eliminate venting.