

Well Name: N HOBBS GB-SA	Well Location: T18S / R38E / SEC 30 / SWSE / 32.7138547 / -103.1846261	County or Parish/State: LEA / NM
Well Number: 341	Type of Well: OIL WELL	Allottee or Tribe Name:
Lease Number: NMLC032233A	Unit or CA Name: NORTH HOBBS GB-SA UNIT	Unit or CA Number: NMNM70997X
US Well Number: 3002524665	Operator: OCCIDENTAL PERMIAN LIMITED	

Notice of Intent

Sundry ID: 2895419

Type of Submission: Notice of Intent

Type of Action: Workover Operations

Date Sundry Submitted: 02/11/2026

Time Sundry Submitted: 08:29

Date proposed operation will begin: 03/11/2026

Procedure Description: Objective: Perform production log and Cement Squeeze perfs to shut-off high gas production. Please see attached detailed planned procedure and current/proposed wellbore diagrams.

Surface Disturbance

Is any additional surface disturbance proposed?: No

NOI Attachments

Procedure Description

NHU_30_341_Job_Plan___WBDs_20260211082605.pdf

Well Name: N HOBBS GB-SA

Well Location: T18S / R38E / SEC 30 / SWSE / 32.7138547 / -103.1846261

County or Parish/State: LEA / NM

Well Number: 341

Type of Well: OIL WELL

Allottee or Tribe Name:

Lease Number: NMLC032233A

Unit or CA Name: NORTH HOBBS GB-SA UNIT

Unit or CA Number: NMNM70997X

US Well Number: 3002524665

Operator: OCCIDENTAL PERMIAN LIMITED

Conditions of Approval

Specialist Review

Workover_or_Vertical_Deepen_COA_20260220123912.pdf

Operator

I certify that the foregoing is true and correct. Title 18 U.S.C. Section 1001 and Title 43 U.S.C. Section 1212, make it a crime for any person knowingly and willfully to make to any department or agency of the United States any false, fictitious or fraudulent statements or representations as to any matter within its jurisdiction. Electronic submission of Sundry Notices through this system satisfies regulations requiring a

Operator Electronic Signature: RONI MATHEW

Signed on: FEB 11, 2026 08:27 AM

Name: OCCIDENTAL PERMIAN LIMITED

Title: REGULATORY SPECIALIST

Street Address: 5 Greenway Plaza, Suite 110

City: Houston

State: TX

Phone: (713) 215-7827

Email address: RONI_MATHEW@OXY.COM

Field

Representative Name: JIM WILSON

Street Address: 6001 DEAUVILLE BLVD.

City: MIDLAND

State: TX

Zip: 79710

Phone: (575)631-2442

Email address: JIM_WILSON@OXY.COM

BLM Point of Contact

BLM POC Name: JONATHON W SHEPARD

BLM POC Title: Petroleum Engineer

BLM POC Phone: 5752345972

BLM POC Email Address: jshepard@blm.gov

Disposition: Approved

Disposition Date: 02/20/2026

Signature: Jonathon Shepard

Form 3160-5
(October 2024)

UNITED STATES
DEPARTMENT OF THE INTERIOR
BUREAU OF LAND MANAGEMENT

FORM APPROVED
OMB No. 1004-0220
Expires: October 31, 2027

SUNDRY NOTICES AND REPORTS ON WELLS
Do not use this form for proposals to drill or to re-enter an abandoned well. Use Form 3160-3 (APD) for such proposals.

SUBMIT IN TRIPLICATE - Other instructions on page 2		5. Lease Serial No.
1. Type of Well <input type="checkbox"/> Oil Well <input type="checkbox"/> Gas Well <input type="checkbox"/> Other		6. If Indian, Allottee or Tribe Name
2. Name of Operator		7. If Unit of CA/Agreement, Name and/or No.
3a. Address	3b. Phone No. (include area code)	8. Well Name and No.
4. Location of Well (Footage, Sec., T.,R.,M., or Survey Description)		9. API Well No.
		10. Field and Pool or Exploratory Area
		11. Country or Parish, State

12. CHECK THE APPROPRIATE BOX(ES) TO INDICATE NATURE OF NOTICE, REPORT OR OTHER DATA

TYPE OF SUBMISSION	TYPE OF ACTION			
<input type="checkbox"/> Notice of Intent	<input type="checkbox"/> Acidize	<input type="checkbox"/> Deepen	<input type="checkbox"/> Production (Start/Resume)	<input type="checkbox"/> Water Shut-Off
<input type="checkbox"/> Subsequent Report	<input type="checkbox"/> Alter Casing	<input type="checkbox"/> Hydraulic Fracturing	<input type="checkbox"/> Reclamation	<input type="checkbox"/> Well Integrity
<input type="checkbox"/> Final Abandonment Notice	<input type="checkbox"/> Casing Repair	<input type="checkbox"/> New Construction	<input type="checkbox"/> Recomplete	<input type="checkbox"/> Other
	<input type="checkbox"/> Change Plans	<input type="checkbox"/> Plug and Abandon	<input type="checkbox"/> Temporarily Abandon	
	<input type="checkbox"/> Convert to Injection	<input type="checkbox"/> Plug Back	<input type="checkbox"/> Water Disposal	

13. Describe Proposed or Completed Operation: Clearly state all pertinent details, including estimated starting date of any proposed work and approximate duration thereof. If the proposal is to deepen directionally or recomplete horizontally, give subsurface locations and measured and true vertical depths of all pertinent markers and zones. Attach the Bond under which the work will be performed or provide the Bond No. on file with BLM/BIA. Required subsequent reports must be filed within 30 days following completion of the involved operations. If the operation results in a multiple completion or recompletion in a new interval, a Form 3160-4 must be filed once testing has been completed. Final Abandonment Notices must be filed only after all requirements, including reclamation, have been completed and the operator has determined that the site is ready for final inspection.)

14. I hereby certify that the foregoing is true and correct. Name (Printed/Typed)	
	Title
Signature	Date

THE SPACE FOR FEDERAL OR STATE OFFICE USE

Approved by		
	Title	Date
Conditions of approval, if any, are attached. Approval of this notice does not warrant or certify that the applicant holds legal or equitable title to those rights in the subject lease which would entitle the applicant to conduct operations thereon.		Office

Title 18 U.S.C Section 1001 and Title 43 U.S.C Section 1212, make it a crime for any person knowingly and willfully to make to any department or agency of the United States any false, fictitious or fraudulent statements or representations as to any matter within its jurisdiction.

(Instructions on page 2)

GENERAL INSTRUCTIONS

This form is designed for submitting proposals to perform certain well operations and reports of such operations when completed as indicated on Federal and Indian lands pursuant to applicable Federal law and regulations. Any necessary special instructions concerning the use of this form and the number of copies to be submitted, particularly with regard to local area or regional procedures and practices, are either shown below, will be issued by or may be obtained from the local Federal office.

SPECIFIC INSTRUCTIONS

Item 4 - Locations on Federal or Indian land should be described in accordance with Federal requirements. Consult the local Federal office for specific instructions.

Item 13: Proposals to abandon a well and subsequent reports of abandonment should include such special information as is required by the local Federal office. In addition, such proposals and reports should include reasons for the abandonment; data on any former or present productive zones or other zones with present significant fluid contents not sealed off by cement or otherwise; depths (top and bottom) and method of placement of cement plugs; mud or other material placed below, between and above plugs; amount, size, method of parting of any casing, liner or tubing pulled and the depth to the top of any tubing left in the hole; method of closing top of well and date well site conditioned for final inspection looking for approval of the abandonment. If the proposal will involve **hydraulic fracturing operations**, you must comply with 43 CFR 3162.3-3, including providing information about the protection of usable water. Operators should provide the best available information about all formations containing water and their depths. This information could include data and interpretation of resistivity logs run on nearby wells. Information may also be obtained from state or tribal regulatory agencies and from local BLM offices.

NOTICES

The privacy Act of 1974 and the regulation in 43 CFR 2.48(d) provide that you be furnished the following information in connection with information required by this application.

AUTHORITY: 30 U.S.C. 181 et seq., 351 et seq., 25 U.S.C. 396; 43 CFR 3160.

PRINCIPAL PURPOSE: The information is used to: (1) Evaluate, when appropriate, approve applications, and report completion of subsequent well operations, on a Federal or Indian lease; and (2) document for administrative use, information for the management, disposal and use of National Resource lands and resources, such as: (a) evaluating the equipment and procedures to be used during a proposed subsequent well operation and reviewing the completed well operations for compliance with the approved plan; (b) requesting and granting approval to perform those actions covered by 43 CFR 3162.3-2, 3162.3-3, and 3162.3-4; (c) reporting the beginning or resumption of production, as required by 43 CFR 3162.4-1(c) and (d) analyzing future applications to drill or modify operations in light of data obtained and methods used.

ROUTINE USES: Information from the record and/or the record will be transferred to appropriate Federal, State, local or foreign agencies, when relevant to civil, criminal or regulatory investigations or prosecutions in connection with congressional inquiries or to consumer reporting agencies to facilitate collection of debts owed the Government.

EFFECT OF NOT PROVIDING THE INFORMATION: Filing of this notice and report and disclosure of the information is mandatory for those subsequent well operations specified in 43 CFR 3162.3-2, 3162.3-3, 3162.3-4.

The Paperwork Reduction Act of 1995 requires us to inform you that:

The BLM collects this information to evaluate proposed and/or completed subsequent well operations on Federal or Indian oil and gas leases.

Response to this request is mandatory.

The BLM would like you to know that you do not have to respond to this or any other Federal agency-sponsored information collection unless it displays a currently valid OMB control number.

BURDEN HOURS STATEMENT: Public reporting burden for this form is estimated to average 8 hours per response, including the time for reviewing instructions, gathering and maintaining data, and completing and reviewing the form. Direct comments regarding the burden estimate or any other aspect of this form to U.S. Department of the Interior, Bureau of Land Management (1004-0137), Bureau Information Collection Clearance Officer (WO-630), 1849 C St., N.W., Mail Stop 401 LS, Washington, D.C. 20240

Additional Information

Location of Well

0. SHL: SWSE / 990 FSL / 1650 FEL / TWSP: 18S / RANGE: 38E / SECTION: 30 / LAT: 32.7138547 / LONG: -103.1846261 (TVD: 0 feet, MD: 0 feet)

BHL: SWSE / 990 FSL / 1650 FEL / TWSP: 18S / SECTION: / LAT: 0.0 / LONG: 0.0 (TVD: 0 feet, MD: 0 feet)

Objective: Perform production log and Cement Squeeze perfs to shut-off high gas production.

Job Plan:

1. Pull ESP equipment.
2. Run production to verify zones of high gas production (suspected Zn1A and Zn2CU)
3. Cement Sqz upper perfs (Zn1A/Zn2CU) f/ 4013'-4103' w/ ~400 sx Class C cmt.
4. DO & Pressure Test Sqz x CO to 4284' PBTD.
5. Reperf & AT lower perforations f/ 4104' to 4276' as required.
6. Install ESP equipment.
7. Return well to production.

Current



NHU 30-341 Current Wellbore Diagram (as of Feb 2026)

*Note: Diagram not to scale

API (10): 30-025-24665

Equipment in well:

Installed 03-30-2021: 2-3/8" tubing and ESP, sensor @3674'.

Perforation Summary:

Open: 4013'-24', 4031'-42', 4090'-93', 4112', 14', 19', 23', 28', 4132'-38', 4166'-71', 4183'-86', 4192'-95', 4208'-16', 4220'-22', 4231'-37', 4247'-49', 4258'-60', 4264'-65', 4273'-76'

Squeezed: 4043', 46', 49', 52', 4056'-65', 4067'-69', 4073'-77', 4103', 05', 09', 11',

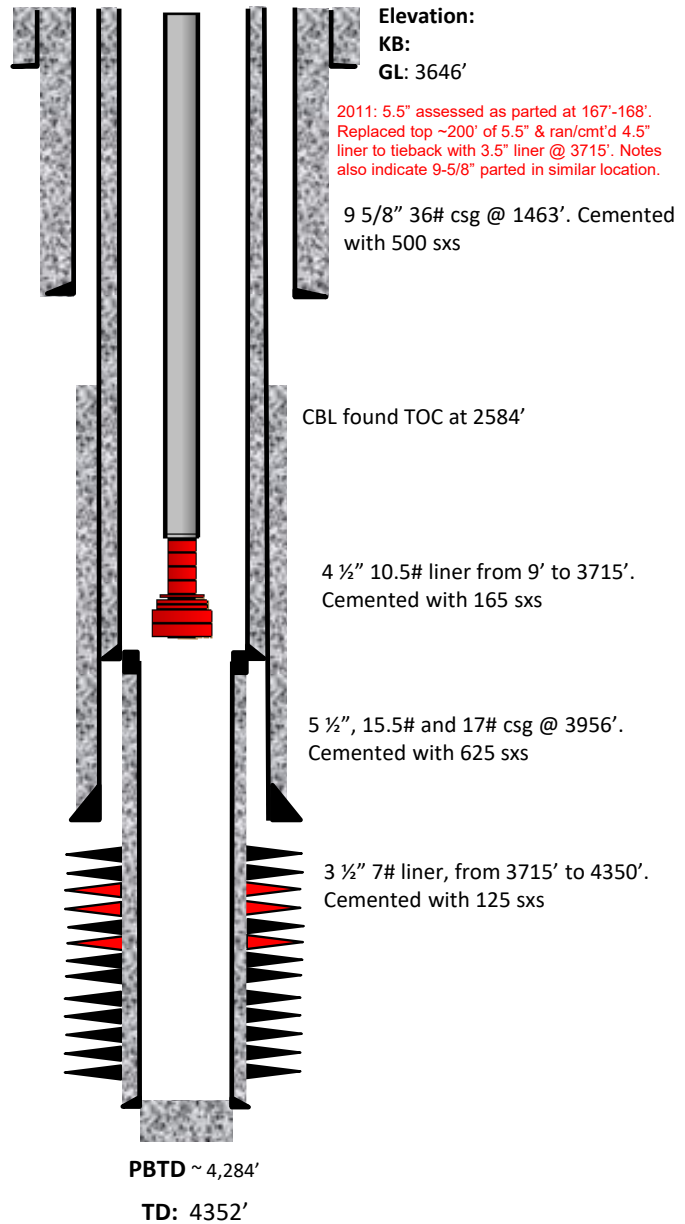

Proposed



NHU 30-341 PROPOSED Wellbore Diagram

*Note: Diagram not to scale

API (10): 30-025-24665

Elevation:

KB:

GL: 3646'

Equipment in well:

Installed 03-30-2021: 2-3/8" tubing and ESP, sensor @3674'.

Perforation Summary:

Open: 4104' to 4276' gross

Squeezed: 4013'-24', 4031'-42', 4043', 46', 49', 52', 4056'-65', 4067'-69', 4073'-77', 4090'-93', 4103'

2011: 5.5" assessed as parted at 167'-168'. Replaced top ~200' of 5.5" & ran/cmt'd 4.5" liner to tieback with 3.5" liner @ 3715'. Notes also indicate 9-5/8" parted in similar location.

9 5/8" 36# csg @ 1463'. Cemented with 500 sxs

CBL found TOC at 2584'

4 1/2" 10.5# liner from 9' to 3715'. Cemented with 165 sxs

5 1/2", 15.5# and 17# csg @ 3956'. Cemented with 625 sxs

3 1/2" 7# liner, from 3715' to 4350'. Cemented with 125 sxs

PBTD ~ 4,284'

TD: 4352'

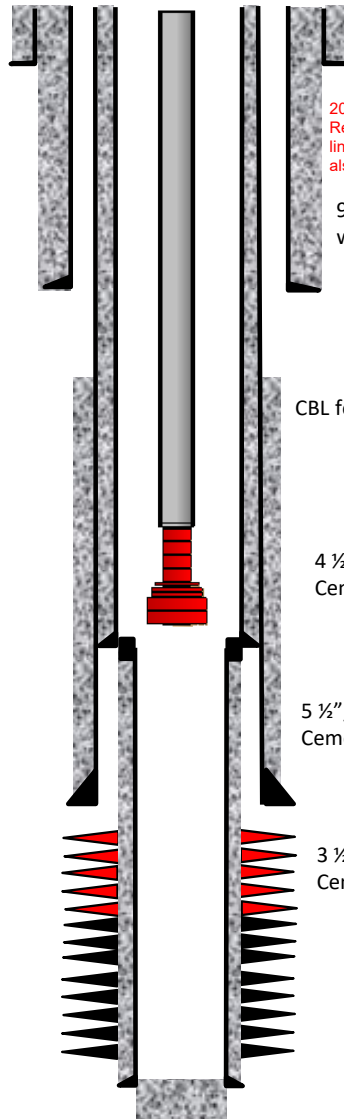

BUREAU OF LAND MANAGEMENT

Carlsbad Field Office
620 East Greene Street
Carlsbad, New Mexico 88220
575-234-5972

Conditions of Approval for Workover/Deepening of a Well

1. Notification: Contact the appropriate BLM office at least 24 hours prior to the commencing of any operations. For wells in Eddy County, call 575-361-2822. For wells in Lea County, call 575-689-5981
2. Blowout Preventers: A blowout preventer (BOP), as appropriate, shall be installed before commencing any operation. The BOP must be installed and maintained as per API and manufacturer recommendations. The minimum BOP requirement is a 2M system for a well not deeper than 9,100 feet, a 3M system for a well not deeper than 13,600 feet, or a 5M system for a well not deeper than 22,700 feet (all depths are for measured well depth).
3. Cement: Notify BLM if cement fails to circulate.
4. Subsequent Reporting: Within 30 days after work is completed, file a Subsequent Report (Form 3160-5) to BLM. The report should give in detail the manner in which the work was carried out. Show date work was completed. If producing a new zone, submit a Completion Report (Form 3160-4) with the Subsequent Report.
5. Trash: All trash, junk and other waste material shall be contained in trash cages or bins to prevent scattering and will be removed and deposited in an approved sanitary landfill. Burial on site is not permitted.
6. If well location is within the Timing Limitation Stipulation Area for Lesser Prairie-Chicken: From March 1st through June 15th annually, activities will be allowed except between the hours from 3:00 am and 9:00 am. Normal vehicle use on existing roads will not be restricted.

Sante Fe Main Office
Phone: (505) 476-3441

General Information
Phone: (505) 629-6116

Online Phone Directory
<https://www.emnrd.nm.gov/ocd/contact-us>

State of New Mexico
Energy, Minerals and Natural Resources
Oil Conservation Division
1220 S. St Francis Dr.
Santa Fe, NM 87505

CONDITIONS

Action 556728

CONDITIONS

Operator: OCCIDENTAL PERMIAN LTD P.O. Box 4294 Houston, TX 772104294	OGRID: 157984
	Action Number: 556728
	Action Type: [C-103] NOI Workover (C-103G)

CONDITIONS

Created By	Condition	Condition Date
dmcclure	None	2/26/2026