

Santa Fe Main Office
Phone: (505) 476-3441
General Information
Phone: (505) 629-6116

State of New Mexico
Energy, Minerals and Natural Resources

Online Phone Directory Visit:
<https://www.emnrd.nm.gov/ocd/contact-us/>

OIL CONSERVATION DIVISION
1220 South St. Francis Dr.
Santa Fe, NM 87505

SUNDRY NOTICES AND REPORTS ON WELLS (DO NOT USE THIS FORM FOR PROPOSALS TO DRILL OR TO DEEPEN OR PLUG BACK TO A DIFFERENT RESERVOIR. USE "APPLICATION FOR PERMIT" (FORM C-101) FOR SUCH PROPOSALS.)		WELL API NO. 30-025-30101
1. Type of Well: Oil Well <input checked="" type="checkbox"/> Gas Well <input type="checkbox"/> Other <input type="checkbox"/>		5. Indicate Type of Lease STATE <input checked="" type="checkbox"/> FEE <input type="checkbox"/>
2. Name of Operator Spur Energy Partners LLC's on NMOCD's behalf for POCO Resources LLC		6. State Oil & Gas Lease No.
3. Address of Operator 9655 Katy Freeway, Suite 500, Houston, TX 77024		7. Lease Name or Unit Agreement Name PETRUS AEO STATE
4. Well Location Unit Letter <u>G</u> : <u>1980</u> feet from the <u>North</u> line and <u>1650</u> feet from the <u>East</u> line Section <u>11</u> Township <u>17S</u> Range <u>33E</u> NMPM <u>Lea</u> County		8. Well Number 002
11. Elevation (Show whether DR, RKB, RT, GR, etc.) 4157' GR		9. OGRID Number 328947
10. Pool name or Wildcat Sanmal; Queen		

12. Check Appropriate Box to Indicate Nature of Notice, Report or Other Data

NOTICE OF INTENTION TO: PERFORM REMEDIAL WORK <input type="checkbox"/> PLUG AND ABANDON <input checked="" type="checkbox"/> TEMPORARILY ABANDON <input type="checkbox"/> CHANGE PLANS <input type="checkbox"/> PULL OR ALTER CASING <input type="checkbox"/> MULTIPLE COMPL <input type="checkbox"/> DOWNHOLE COMMINGLE <input type="checkbox"/> CLOSED-LOOP SYSTEM <input type="checkbox"/> OTHER: <input type="checkbox"/>		SUBSEQUENT REPORT OF: REMEDIAL WORK <input type="checkbox"/> ALTERING CASING <input type="checkbox"/> COMMENCE DRILLING OPNS. <input type="checkbox"/> P AND A <input type="checkbox"/> CASING/CEMENT JOB <input type="checkbox"/> OTHER: <input type="checkbox"/>	
---	--	---	--

13. Describe proposed or completed operations. (Clearly state all pertinent details, and give pertinent dates, including estimated date of starting any proposed work). SEE RULE 19.15.7.14 NMAC. For Multiple Completions: Attach wellbore diagram of proposed completion or recompletion.

Spur Energy Partners LLC requests to plug and abandon this well on behalf of the NMOCD pursuant to NMOCD's Order No. 24202 in Case No. 25794.

Please find the proposed plugging procedure, current and as-plugged wellbore diagrams for your review.

Spud Date:

Rig Release Date:

I hereby certify that the information above is true and complete to the best of my knowledge and belief.

SIGNATURE Sarah Savino TITLE Regulatory Director DATE 02/24/2026

Type or print name Sarah Savino E-mail address: ssavino@spurenergy.com PHONE: 832-930-8613

For State Use Only

APPROVED BY: _____ TITLE _____ DATE _____

Conditions of Approval (if any): _____

Petrus AEO State 2
Eddy County, NM
API: 30-025-30101

Petrus AEO State 2 P&A Procedure

1. POOH with all tubing and rods in the hole.
2. Set 5-1/2" CIBP at 3719'. Pressure test casing to 500psi for 30mins. Run CBL from 3719' to surface. Spot 25 sxs of Class C Cmt from 3719'-3472. WOC and Tag. (Top Perf, Queen)
3. Plug 2: Spot 30 sxs of Class C Cmt from 2861'-2570'. WOC and tag. (Yates, Salt Base)
4. Plug 3: Perf and Squeeze 105 sxs Class C Cmt from 1679'-1462'. WOC and tag. (Surface Shoe, Salt Top)
5. Plug 4: Perf and squeeze 57 sxs Class C Cmt from 100'- surface.
6. Cut-off wellhead. Install below ground dryhole marker.

Lea County, NM
API# 30-025-30101

SPUD DATE: 10/15/1987
ELEV: 4157'
SURFACE HOLE LOCATION:
32.851106, -103.630769

EVENT LOG
10/22/1987- DRILLED WELL
11/12/1987- COMPLETED WELL

CURRENT WBD

SURFACE

8-5/8" 24# J-55 Csg 0'-1512'

CMT W/750 SXS CLASS C

CIRC 30 SXS TO SURFACE, TOC AT SURFACE

PRODUCTION

5-1/2" 15.5# J-55 Csg 0'-3900'

CMT W/175 SXS CLASS C

ESTIMATED TOC AT 2565'

2-7/8" 6.5# J-55 Bare Tubing
EOT @ 3737'

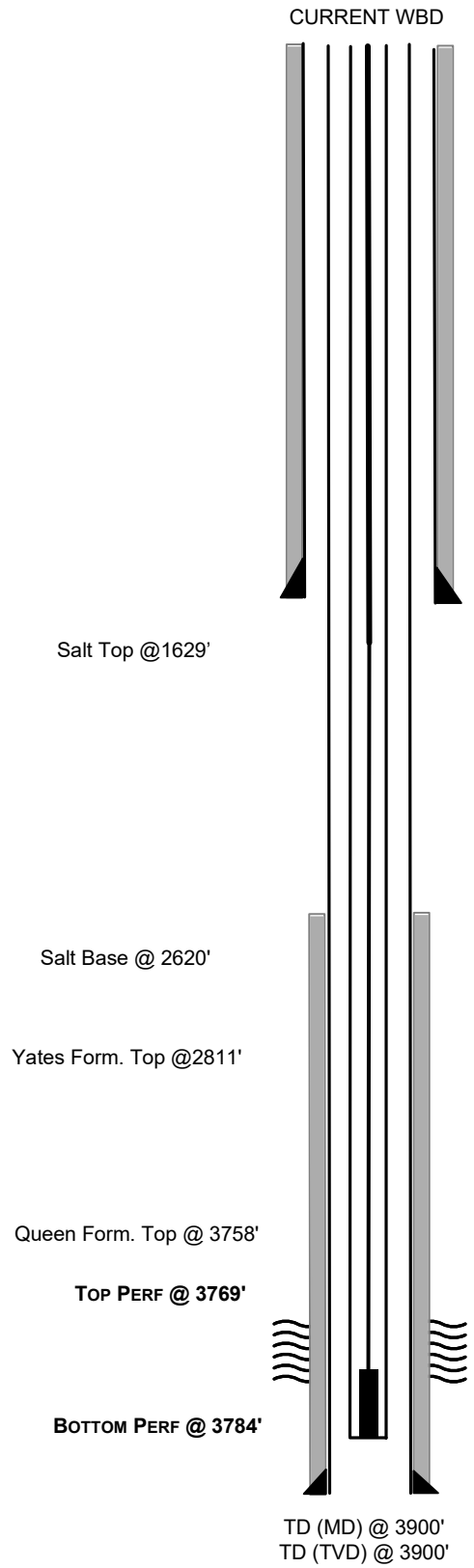

Lea County, NM
API# 30-025-30101

SPUD DATE: 10/15/1987
ELEV: 4157'
SURFACE HOLE LOCATION:
32.851106, -103.630769

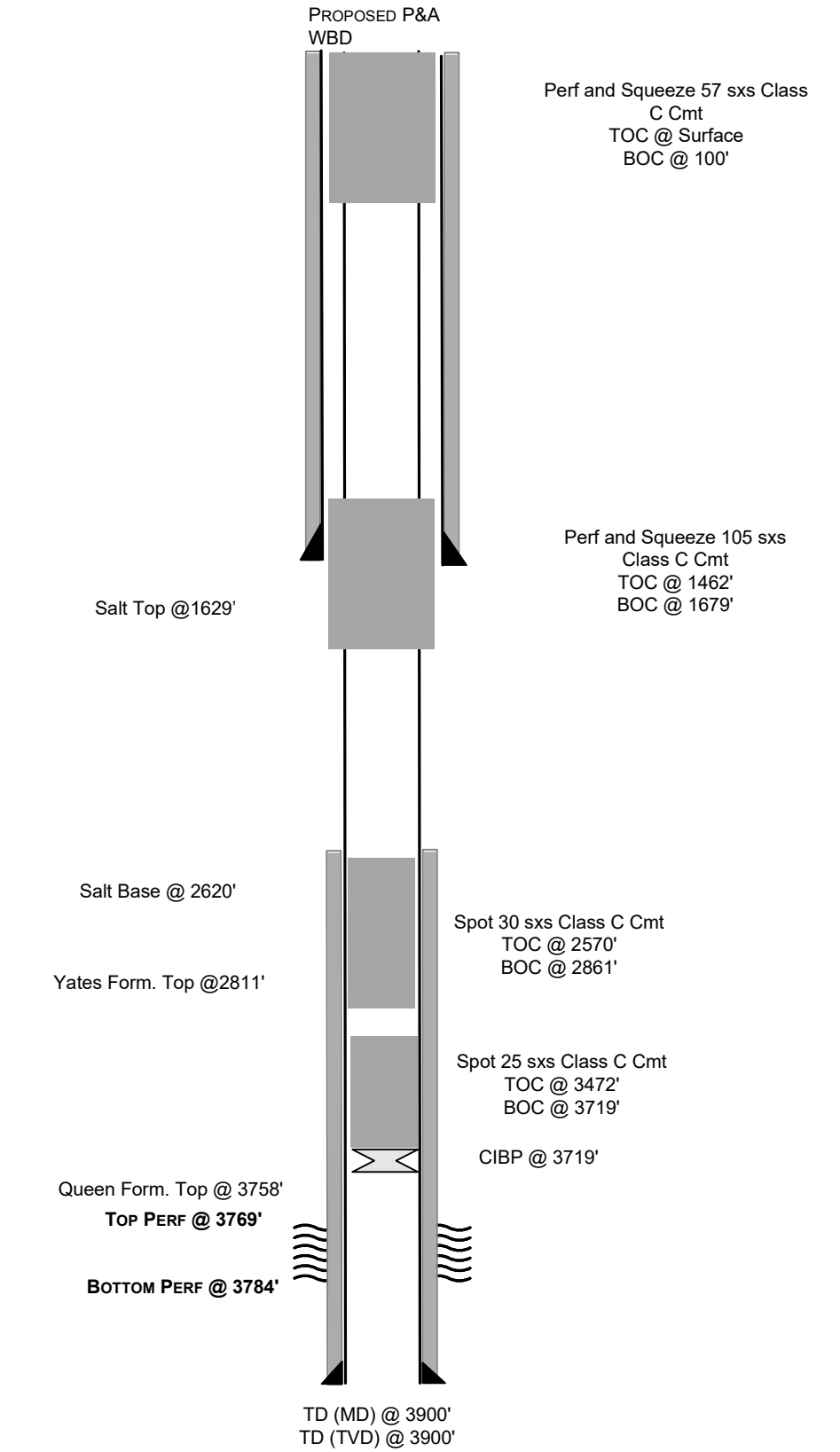

EVENT LOG
10/22/1987- DRILLED WELL
11/12/1987- COMPLETED WELL

SURFACE
8-5/8" 24# J-55 Csg 0'-1512'
CMT w/750 sxs CLASS C
CIRC 30 SXS TO SURFACE, TOC AT SURFACE

PRODUCTION
5-1/2" 15.5# J-55 Csg 0'-3900'
CMT w/175 sxs CLASS C
ESTIMATED TOC AT 2565'

Sante Fe Main Office
Phone: (505) 476-3441

General Information
Phone: (505) 629-6116

Online Phone Directory
<https://www.emnrd.nm.gov/ocd/contact-us>

State of New Mexico
Energy, Minerals and Natural Resources
Oil Conservation Division
1220 S. St Francis Dr.
Santa Fe, NM 87505

CONDITIONS

Action 557110

CONDITIONS

Operator: Spur Energy Partners LLC 9655 Katy Freeway Houston, TX 77024	OGRID: 328947
	Action Number: 557110
	Action Type: [C-103] NOI Plug & Abandon (C-103F)

CONDITIONS

Created By	Condition	Condition Date
loren.diede	Notify the OCD inspection supervisor via email 24 hours prior to beginning Plug & Abandon (P&A) operations.	3/16/2026
loren.diede	NMOCD requests that the 7 Rivers formation top be covered. Top picked at 2914'. Possibly extend the BOC for Plug 2 to cover the 7 Rivers.	3/16/2026
loren.diede	Extend the surface casing shoe plug to cover the Rustler. Rustler top picked at 1512'.	3/16/2026
loren.diede	Submit photo and GPS coordinates of the P&A marker with the C-103P subsequent P&A report. The API# on the marker must be clearly legible.	3/16/2026