

**STATE OF NEW MEXICO
DEPARTMENT OF ENERGY, MINERALS AND NATURAL RESOURCES
OIL CONSERVATION DIVISION**

**APPLICATION OF OXY USA INC. FOR A
CLOSED LOOP GAS CAPTURE INJECTION
PILOT PROJECT, LEA COUNTY, NEW
MEXICO.**

CASE NO. _____

APPLICATION

OXY USA Inc. (“OXY” or “Applicant”) (OGRID No. 16696) through its undersigned attorneys, hereby files this application with the Oil Conservation Division for an order authorizing OXY to engage in a closed loop gas capture injection pilot project in the Bone Spring formation (“pilot project”). In support of this application, OXY states:

PROJECT OVERVIEW

1. OXY proposes to create a 640-acre project area for this pilot project consisting of the E/2 of Sections 8 and 17, all within Township 24 South, Range 32 East, NMPM, Lea County, New Mexico. See **Exhibit A** at 6. The project area is located entirely within OXY’s Mesa Verde Bone Spring Unit, which is comprised of 3,461 acres, more or less, as follows:

Township 24 South, Range 32 East

- Section 7: SE/4, E/2 NE/4
- Section 8: All
- Section 9: W/2
- Section 16: W/2
- Section 17: All
- Section 18: All

Township 24 South, Range 31 East

- Section 13: All

2. Within the proposed project area, OXY seeks authority to utilize the following producing wells to occasionally inject produced gas into the Bone Spring formation, Mesa Verde Bone Spring Pool (96229):

- The Mesa Verde BS Unit 1H well (API No. 30-025-44101), with a surface location 271 feet FSL and 245 feet FEL (Unit P) in Section 17, and a bottom hole location 335 feet FNL and 992 feet FEL (Unit A) in Section 8;
- The Mesa Verde BS Unit 2H well (API No. 30-025-44196), with a surface location 240 feet FSL and 1,614 feet FEL (Unit O) in Section 17, and a bottom hole location 171 feet FNL and 1,275 feet FEL (Unit A) in Section 8;
- Mesa Verde BS Unit 3H well (API No. 30-025-44183), with a surface location 240 feet FSL and 1,644 feet FEL (Unit O) in Section 17, and a bottom hole location 197 feet FNL and 2,368 feet FEL (Unit B) in Section 8;
- Mesa Verde BS Unit 4H well (API No. 30-025-44064), with a surface location 280 feet FSL and 965 feet FEL (Unit P) in Section 17, and a bottom hole location 185 feet FNL and 512 feet FEL (Unit A) in Section 8;
- Mesa Verde BS Unit 5H well (API No. 30-025-44185), with a surface location 280 feet FSL and 995 feet FEL (Unit P) in Section 17, and a bottom hole location 196 feet FNL and 1,329 feet FEL (Unit B) in Section 8; and
- Mesa Verde BS Unit 6H well (API No. 30-025-44042), with a surface location 280 feet FSL and 2,624 feet FEL (Unit O) in Section 17, and a bottom hole location 206 feet FNL and 2,292 feet FEL (Unit B) in Section 8.

3. Injection along the horizontal portion of the wellbores will be at the following approximate total vertical depths:

- The Mesa Verde BS Unit 1H well: between 9,247 feet and 9,290 feet;
- The Mesa Verde BS Unit 2H well: between 11,815 feet and 11,860 feet;
- Mesa Verde BS Unit 3H well: between 9,901 feet and 9,216 feet;
- Mesa Verde BS Unit 4H well: between 10,339 feet and 10,448 feet;
- Mesa Verde BS Unit 5H well: between 10,339 feet and 10,449 feet; and
- Mesa Verde BS Unit 6H well: between 10,385 feet and 10,409 feet.

See Exhibit A at 14-15, 20-21, 27-28, 33-34, 40-41, 47-48 and 74.

4. A map depicting the pipeline that ties the wells proposed for the pilot project into the gathering system and the affected compressor station is included in the attached Exhibit A at page 5.

WELL DATA

5. Information on the well data, including well diagrams and well construction, casing, tubing, packers, cement, perforations, and other details for each proposed injection well are included in the attached Exhibit A at pages 14-15, 20-21, 27-28, 33-34, 40-41, 47-48 and 74, respectively.

6. The top of the Bone Spring formation in this area is at approximately 8,593 feet total vertical depth and extends down to the top of the Wolfcamp formation at approximately 12,100 feet total vertical depth. See Exhibit A at 79, 82-84.

7. The current average surface pressures under normal operations for the proposed injection wells range from approximately 520 psi to 1,100 psi. See Exhibit A at 54. The maximum achievable surface pressure (MASP) for the wells in the pilot project will be 1,200 psi. *Id.*

8. OXY plans to monitor injection and operational parameters for the pilot project using an automated supervisory control and data acquisition (SCADA) system with pre-set alarms

and automatic shut-in safety valves that will prevent injection pressures from exceeding the MASP. *See* Exhibit A at 55-56 and 68-69.

9. The proposed maximum achievable surface pressure will not exert pressure at the top perforation in the wellbore of any injection well with a full fluid column of reservoir brine water in excess of 90% of the burst pressure for the production casing or production liner. *See* Exhibit A at 54. In addition, the proposed maximum achievable surface pressure will not exceed 0.14 psi per foot as measured at the top of the uppermost perforation in any injection well and will not exert pressure at the topmost perforation in excess of 90% of the formation parting pressure. *See* Exhibit A at 54.

10. Cement bond logs¹ demonstrate the placement of cement in each of the wells proposed for this pilot project and that there is a good and sufficient cement bond with the production casing and the formation across the top of the proposed injection interval in each well. *See* Exhibit A at 16-19, 22-26, 29-32, 35-39, 42-46, 49-53.

11. All the wells proposed for the pilot project have previously demonstrated mechanical integrity at a pressure of 9,800 psi for thirty minutes. *See* Exhibit A at 57. OXY will undertake new tests to demonstrate mechanical integrity for each of the wells proposed for this pilot project as a condition of approval prior to commencing injection operations.

GEOLOGY AND RESERVOIR

12. Data and a geologic analysis confirming that the Bone Spring formation is suitable for the proposed pilot project is included in Exhibit A at pages 79-85. A general characterization of the geology of the Bone Spring formation and its suitability for the proposed injection, including

¹ Electronic version of the cement bond logs will be submitted to the Division by email.

identification of confining layers and their ability to prevent vertical movement of the injected gas is included in the analysis. *Id.*

13. Zones that are productive of oil and gas are located in Bone Spring intervals above and below the targeted injection interval and in the deeper Wolfcamp formation. *See Exhibit A at 79.*

14. Reservoir modeling indicates anticipated horizontal movement of injected gas will be approximately 100 feet or less from each injection wellbore within the Bone Spring formation. *See Exhibit A at 92.*

15. The proposed average injection rate for each well is 1.8 MMSCFD with a maximum injection rate of 3.0 MMSCFD during injection. *See Exhibit A at 54.*

16. OXY has prepared calculations estimating the stimulated reservoir volume based on supporting empirical data and a reservoir model to evaluate potential effects on wells adjacent to the pilot project area. *See Exhibit A at 87-97.* OXY's analysis concludes that there will be no change in the oil recovery from each of its proposed injection wells or from any of the offsetting wells. *See id.* at 95.

17. Similarly, OXY has prepared an analysis of the potential effects on the reservoir caused by the proposed injection, including consideration of commingling fluids. *Exhibit A at 60-65, 87-97.* OXY's analysis concludes that there will be no adverse effect on the reservoir as a result of the injection. *Id.*

18. OXY has also prepared an analysis evaluating the expected gas storage capacity for each proposed injection well relative to the gas injection volumes for an injection scenario lasting twenty days. *See Exhibit A at 95.* The analysis confirms that whether the capacity is estimated based on the fracture volume gas equivalent or the total gas equivalent volumes produced from the

proposed injection zone, the anticipated gas injection volumes will be well below the estimated volume capacity within the project area.

19. The source of gas for injection will be from wells producing in the Bone Spring and Wolfcamp formations within OXY's Mesa Verde Bone Spring Unit and Mesa Verde Wolfcamp Unit that are identified in the list of wells in Exhibit A at page 59. OXY's Mesa Verde Wolfcamp Unit is comprised of the same acreage as the Mesa Verde Bone Spring Unit identified in Paragraph 1, above. The unit interest owners are identical between the units.

20. OXY has prepared an analysis of the composition of the source gas for injection and a corrosion prevention plan. *See* Exhibit A at 60-66.

21. OXY has examined the available geologic and engineering data and found no evidence of open faults or other hydrologic connections between the injection zone and any underground source of drinking water. *See* Exhibit A at 85. OXY has also examined the available geologic and engineering data and determined that the total recoverable volume of hydrocarbons from the reservoir will not be adversely affected by the pilot project. *See* Exhibit A at 97.

AREA OF REVIEW

22. OXY has prepared maps depicting the location of each proposed injection well, the location and lateral of every well within a two-mile radius, leases within two miles, and the half-mile area of review. *See* Exhibit A at 71-73.

23. A tabulation of data for wells that penetrate the proposed injection intervals or the confining layer within the area of review is included in Exhibit A at pages 74-75, along with well-bore schematics for wells that are plugged and abandoned or temporarily abandoned. *See* Exhibit A at 76-77.

OPERATIONS AND SAFETY

24. OXY will monitor each injection well's instantaneous rates and daily injection volumes, along with pressure in the well tubing, casing, and bradenheads using an automated supervisory control and data acquisition (SCADA) system. *See* Exhibit A at 55-56 and 68-69. Each injection well will also include automated safety devices, including automatic shut-in valves among other operational safety measures. *Id.* OXY will also monitor and track various operational parameters at the pilot project's central tank battery and central gas lift compressors. *See* Exhibit A at 68-69.

25. A copy of this application will be provided by certified mail to the surface owner on which each injection well identified herein is located, and to each leasehold operator and other affected persons within any tract wholly or partially contained within one-half mile of the completed interval of the wellbore for each of the proposed injection wells. A copy of the affected parties subject to notice is included in Exhibit A at pages 101-102, along with a map and list identifying each tract and affected persons given notice. *See* Exhibit A at 99-100.

26. Approval of this pilot project is in the best interests of conservation, the prevention of waste, and the protection of correlative rights.

WHEREFORE, OXY USA Inc. requests that this Application be set for hearing before an Examiner of the Oil Conservation Division on August 5, 2021, and that after notice and hearing this Application be approved.

Respectfully submitted,

HOLLAND & HART LLP

By: _____



Michael H. Feldewert
Adam G. Rankin
Julia Broggi
Kaitlyn A. Luck
Post Office Box 2208
Santa Fe, NM 87504
505-998-4421
505-983-6043 Facsimile
mfeldewert@hollandhart.com
agrarkin@hollandhart.com
jbroggi@hollandhart.com
kaluck@hollandhart.com

ATTORNEYS FOR OXY USA INC.

New Mexico Closed Loop Gas Capture (CLGC) Oxy- Mesa Verde

EXHIBIT A



Occidental

Overview

EXHIBIT A

General Project Description: Closed Loop Gas Capture Project Oxy- Mesa Verde

About the Mesa Verde Units

There are two Resource Development Units in Mesa Verde. One is unitized in the Bone Spring formation and the other is unitized in the Wolfcamp formation. Each one has a Unit Agreement and a Unit Operating Agreement, and they were formed in 2017. Both cover exactly the same geographical area (3461.80 acres) and have identical interests. OXY is the designated operator of both units. All the GLGC wells proposed in this application are Mesa Verde Bone Spring Unit wells, and the source wells are either Mesa Verde Bone Spring Unit wells or Mesa Verde Wolfcamp Unit wells.

Summary of Requested Relief

1. Authority to operate a closed loop gas capture project (“CLGC”) consisting of six wells to prevent waste and reduce adverse impacts from temporary interruptions of gas pipeline capacity.
2. A 5-year duration of such authority, with renewal by administrative approval conditioned upon compliance with the stipulations contained in the initial Order and a successful MIT test.
3. An exception for the 100-foot packer setting depth requirement applied to vertical injection wells.

Overview

Oxy USA Inc. (Oxy) is proposing a Closed Loop Gas Capture (CLGC) project in the Mesa Verde Unit area. On occasion, third-party gas purchasers reduce takeaway capacity and cause interruptions that result in flaring or shut in production. During these interruptions, Oxy will utilize CLGC wells to capture gas and reduce flaring.

In 2020, Oxy experienced 67 days of interruptions where the third-party gas purchaser temporarily reduced takeaway capacity from this location, resulting in the flaring of at least 96 MMSCF of gas or the immediate shut-in of at least 10,000 BOPD. Approval of this application will significantly reduce such flaring or shut-in production in the future.

Operations During Interruption	Operations During Interruption With CLGC System	Benefits
<ul style="list-style-type: none"> Flare gas Shut in production 	<ul style="list-style-type: none"> Store gas Continue production No additional surface disturbances 	<ul style="list-style-type: none"> Reduce greenhouse gas emissions Improve economic recovery of mineral resources including gas that might have been flared Utilize existing infrastructure

Proposed Operations

Oxy has an extensive high-pressure gas system in the Mesa Verde Unit area. It is used for gas lift, a type of artificial lift. Oxy plans to utilize the same system for gas storage operations. Very minimal equipment on surface will need to be installed prior to starting storage operations.

Enlink is the third-party gas purchaser for Mesa Verde. If an interruption occurs, Oxy will divert gas from the takeaway line back into the gas lift injection system. Gas will flow from the Central Gas Lift (CGL) Compressor Station through the flow meter, control valve, safety shutdown valve, wellhead and into the wellbore for storage. Gas will be injected down the casing/tubing annulus in some wells and down the tubing without a packer in the hole in others. Simultaneously, the proposed CLGC well will be shut in by closing the electric choke upstream of the production flowline. After the interruption has ended, the electric choke will open and the CLGC well resumes production.

Wells

6 wells are proposed in this application.

#	API 14	Well Name	Injection Down the...
1	30025441010100	MV-BS-1H-ST1	Casing
2	30025441960000	MV-BS-2H	Tubing
3	30025441830000	MV-BS-3H	Casing
4	30025440640000	Mesa Verde BS Unit 4H	Tubing
5	30025441850000	Mesa Verde BS Unit 5H	Tubing
6	30025440420000	Mesa Verde BS Unit 6H	Tubing

Timeline

Since no new surface disturbances are required, this project can be implemented with minimal facility modifications. The timeline below assumes an order is issued on January 1 for illustration purposes.

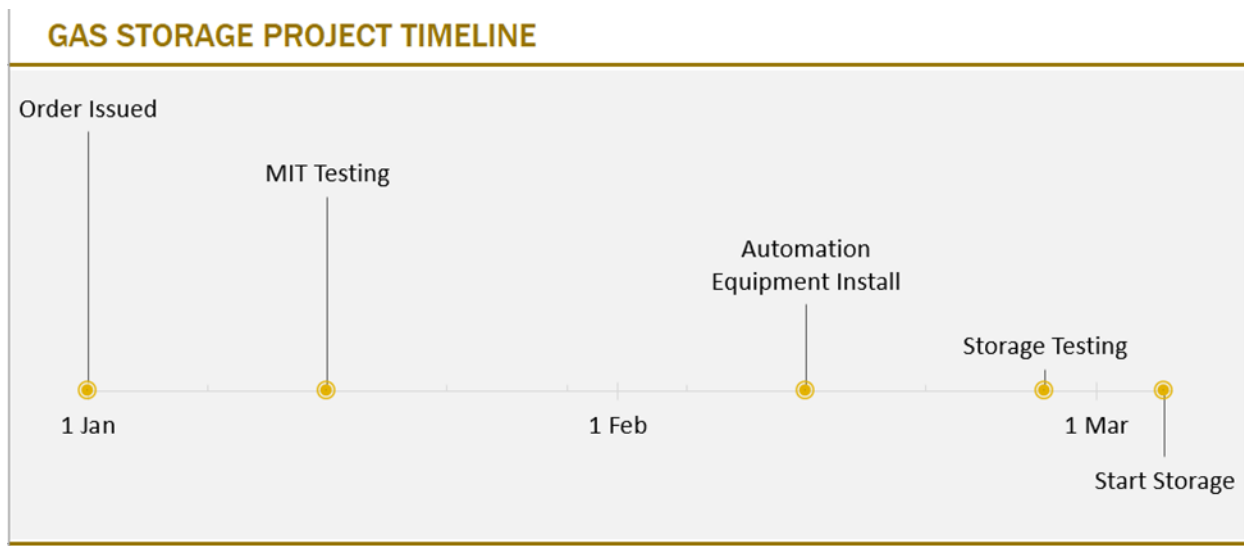

Mesa Verde Gas Storage Process Flow Diagram

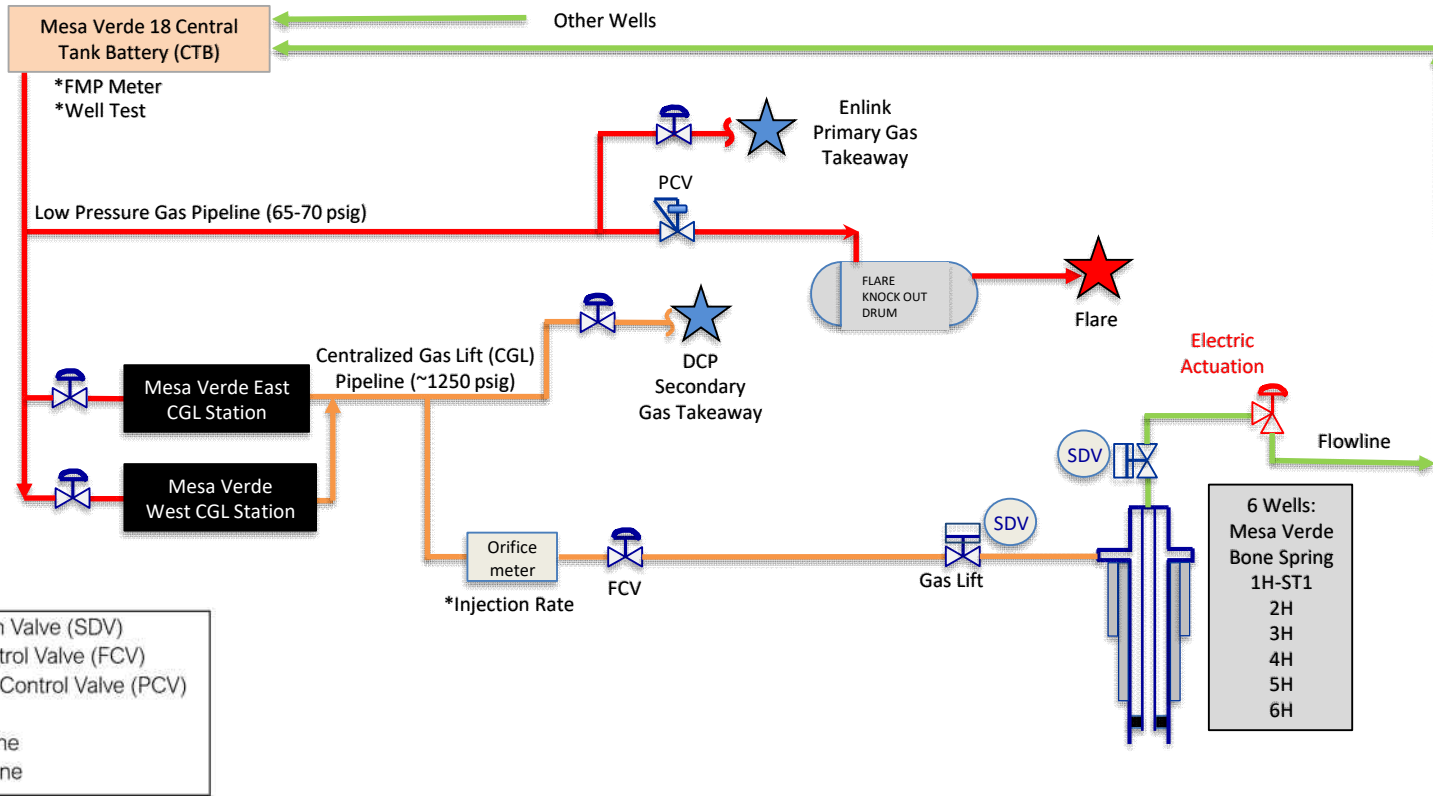

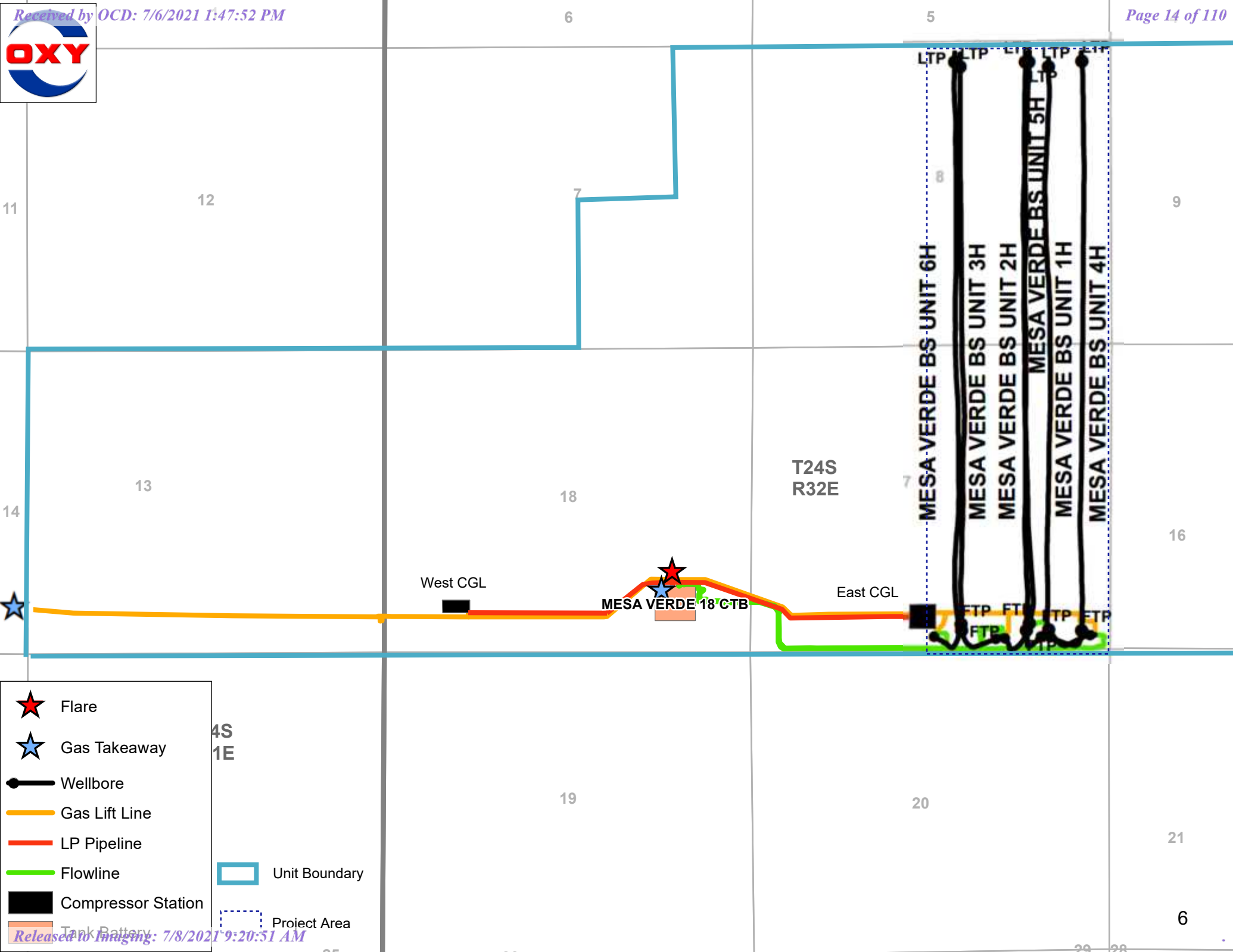

- Flare
- Gas Takeaway
- Wellbore
- Gas Lift Line
- LP Pipeline
- Flowline
- Compressor Station
- Tank Battery

- Unit Boundary
- Project Area

Injection Wellbores

District I
1625 N. French Dr., Hobbs, NM 88240
Phone: (575) 393-6161 Fax: (575) 393-0720
District II
811 S. First St., Artesia, NM 88210
Phone: (575) 748-1283 Fax: (575) 748-9720
District III
1000 Rio Bravo Road, Aztec, NM 87410
Phone: (505) 334-6178 Fax: (505) 334-6170
District IV
1220 S. St. Francis Dr., Santa Fe, NM 87505
Phone: (505) 476-3460 Fax: (505) 476-3462

State of New Mexico
Energy, Minerals & Natural Resources Department
OIL CONSERVATION DIVISION
1220 South St. Francis Dr.
Santa Fe, NM 87505

Form C-102
Revised August 1, 2011
Submit one copy to appropriate
District Office

AMENDED REPORT
(As-Drilled)

WELL LOCATION AND ACREAGE DEDICATION PLAT

API Number 30-025-44101	Pool Code 96229	Pool Name Mesa Verde Bone Spring
Property Code 320828	Property Name MESA VERDE BS UNIT	Well Number 1H
OGRID No. 16696	Operator Name OXY USA INC.	Elevation 3563.6'

Surface Location

UL or lot no.	Section	Township	Range	Lot Idn	Feet from the	North/South line	Feet from the	East/West line	County
P	17	24 SOUTH	32 EAST, N.M.P.M.		271'	SOUTH	245'	EAST	LEA

Bottom Hole Location If Different From Surface

UL or lot no.	Section	Township	Range	Lot Idn	Feet from the	North/South line	Feet from the	East/West line	County
A	8	24 SOUTH	32 EAST, N.M.P.M.		180' 335'	NORTH	992' 992'	EAST	LEA
Dedicated Acres 320	Joint or Infill Y	Consolidation Code	Order No.	LTP - 450 FNL 990 FEL FTP - 353 FSL 925 FEL					

No allowable will be assigned to this completion until all interests have been consolidated or a non-standard unit has been approved by the division.

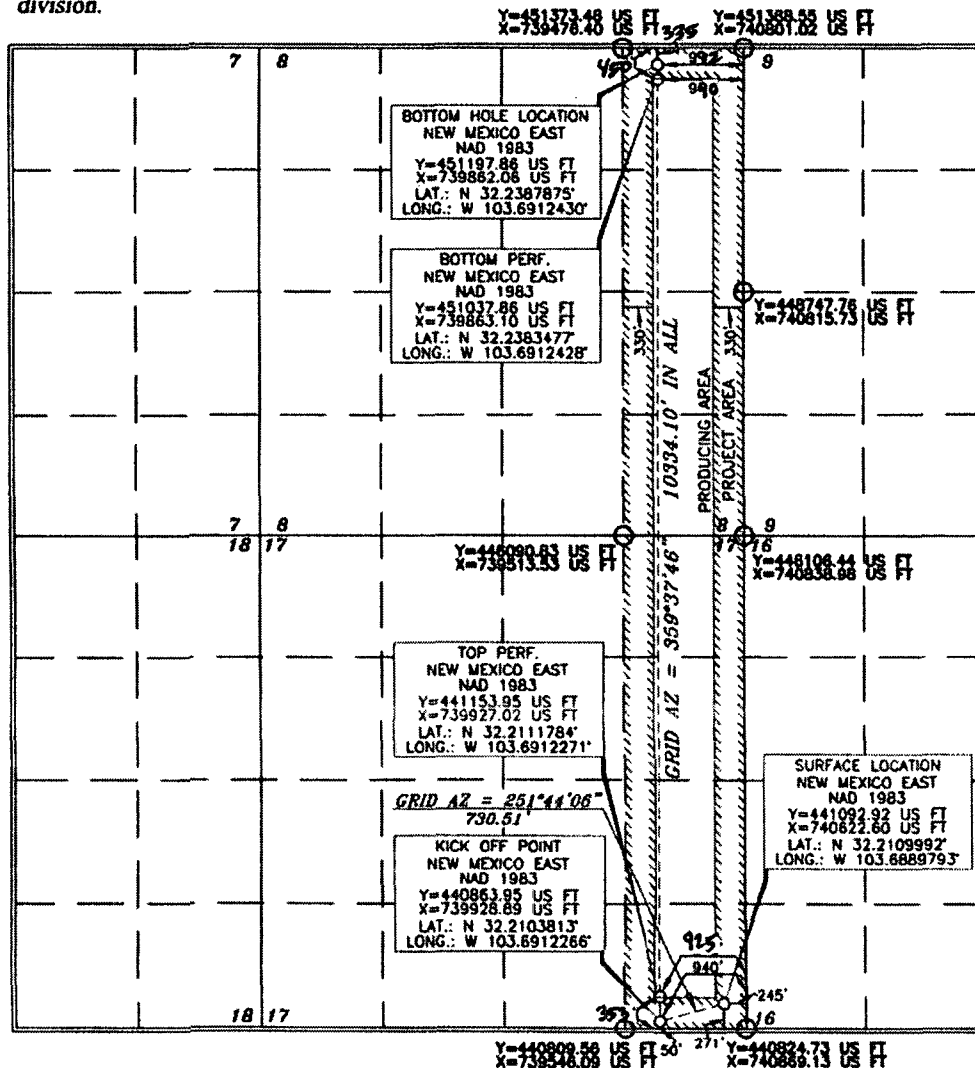

OPERATOR CERTIFICATION

I hereby certify that the information contained herein is true and complete to the best of my knowledge and belief, and that this organization either owns a working interest or unleased mineral interest in the land including the proposed bottom hole location or has a right to drill this well at this location pursuant to a contract with an owner of such a mineral or working interest, or to a voluntary pooling agreement or a compulsory pooling order heretofore entered by the division.

[Signature] 8/16/18
Date
Sana Mendiola
Printed Name
sana@mendiola2oxy.com
E-mail Address

SURVEYOR CERTIFICATION

I hereby certify that the well location shown on this plat was plotted from available professional surveys made by me or under my supervision and that the same is true and correct to the best of my belief.

[Signature]
Date of Survey
SEPTEMBER 28, 2018
Signature and Seal
Professional Surveyor
[Signature]
Certificate Number 15079

District I
1623 N. Francis Dr., Hobbs, NM 88240
Phone: (505) 393-4161 Fax: (505) 393-0776
District II
411 S. First St., Arroyo, NM 88210
Phone: (505) 748-1283 Fax: (505) 748-1720
District III
1000 Rio Grande Road, Aztec, NM 87416
Phone: (505) 334-4173 Fax: (505) 334-4174
District IV
1220 S. St. Francis Dr., Santa Fe, NM 87505
Phone: (505) 476-3450 Fax: (505) 476-3443

State of New Mexico
Energy, Minerals & Natural Resources Department
OIL CONSERVATION DIVISION
1220 South St. Francis Dr.
Santa Fe, NM 87505

Form C-102
Revised August 1, 2011
Submit one copy to appropriate
District Office

AMENDED REPORT
(As-Drilled)

WELL LOCATION AND ACREAGE DEDICATION PLAT

API Number 30-025-44196	Pool Code 96229	Pool Name Mesa Verde Bone Spring
Property Code 320828	Property Name MESA VERDE BS UNIT	Well Number 2H
OGRID No. 16696	Operator Name OXY USA INC.	Elevation 3557.4'

Surface Location

UL or lot no.	Section	Township	Range	Lot Idn	Feet from the	North/South line	Feet from the	East/West line	County
0	17	24 SOUTH	32 EAST, N.M.P.M		240'	SOUTH	1614'	EAST	LEA

Bottom Hole Location If Different From Surface

UL or lot no.	Section	Township	Range	Lot Idn	Feet from the	North/South line	Feet from the	East/West line	County
A	B	24 SOUTH	32 EAST, N.M.P.M		189' 131'	NORTH	1296' 1275'	EAST	LEA
Dedicated Acres 320	Joint or Infill Y	Consolidation Code	Order No.	BP- 350 FUL 1275 FEL TP- 479 FSL 1215 FEL					

No allowable will be assigned to this completion until all interests have been consolidated or a non-standard unit has been approved by the division.

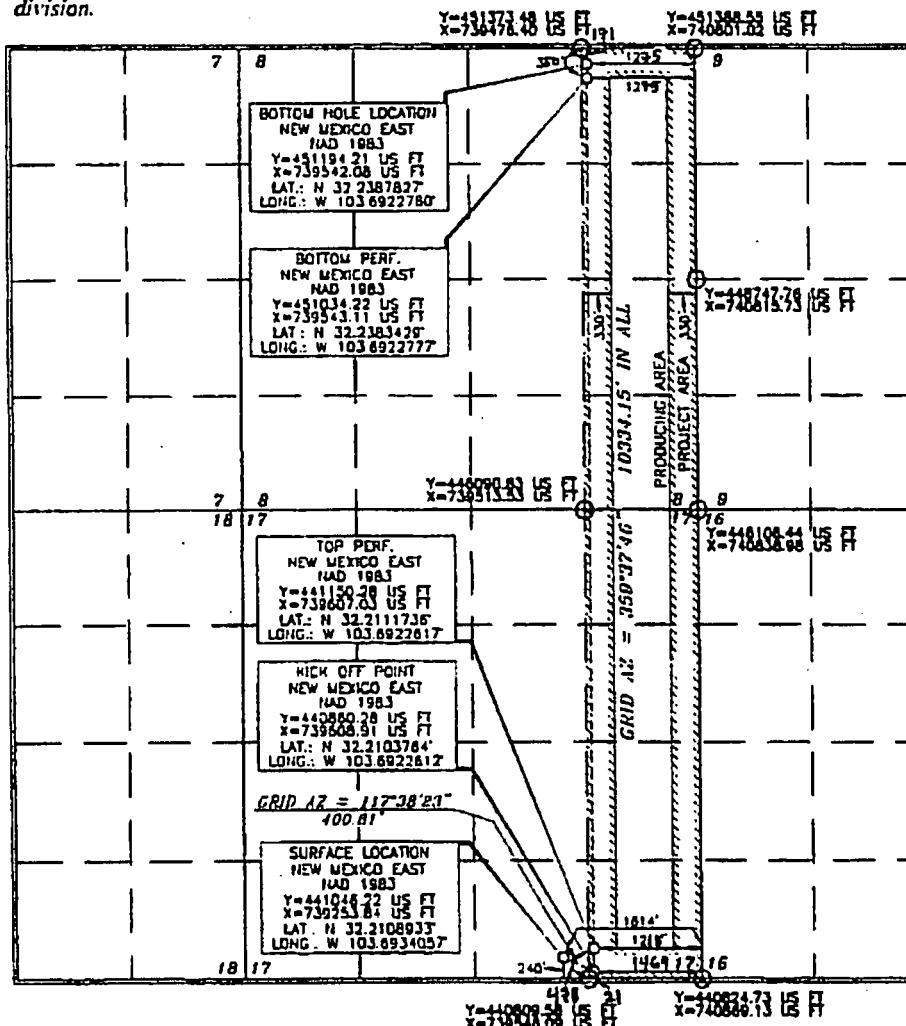

OPERATOR CERTIFICATION
I hereby certify that the information contained herein is true and complete to the best of my knowledge and belief, and that the information reflects a working interest or undivided mineral interest in the land including the proposed location, lease location or has a right to drill the well at the location pursuant to a contract well as owner of such a mineral or working interest, or to a subsidiary pooling agreement or a compulsory pooling order hereby approved by the division.
[Signature] 7/26/18
Jana Mendiola
jyanaln.mendiola@oxy.com

SURVEYOR CERTIFICATION
I hereby certify that the information shown on this plat was obtained from the field by actual surveys made by me, and that my certificate and that the same is true and correct to the best of my belief.
RY J. A. [Signature]
15079
OCTOBER 5, 2018
Date of Survey
Signature and Seal of PROFESSIONAL LAND SURVEYOR
Certificate Number 15879

WO/ 161005HL-b-XY (Rev. A) (02)

District I
1623 N French Dr., Hobbs, NM 88240
Phone: (575) 393-6181 Fax: (575) 393-6720
District II
911 S. First St., Artesia, NM 88210
Phone: (575) 748-1237 Fax: (575) 748-9720
District III
1000 Red Branch Road, Aztec, NM 87410
Phone: (505) 334-6178 Fax: (505) 334-6170
District IV
1200 S. St. Francis Dr., Santa Fe, NM 87501
Phone: (505) 476-3400 Fax: (505) 476-3402

State of New Mexico
Energy, Minerals & Natural Resources Department
OIL CONSERVATION DIVISION
1220 South St. Francis Dr.
Santa Fe, NM 87505

Form C-102
Revised August 1, 2011
Submit one copy to appropriate
District Office

AMENDED REPORT
(As-Drilled)

WELL LOCATION AND ACREAGE DEDICATION PLAT

API Number 30-025-44183	Pool Code 96229	Pool Name Mesa Verde Bore Spring
Property Code 320828	Property Name MESA VERDE BS UNIT	Well Number 3H
OGRID No. 16696	Operator Name OXY USA INC.	Elevation 3557.7'

Surface Location

UL or lot no.	Section	Township	Range	Lot (ch)	Feet from the	North South line	Feet from the	East West line	County
0	17	24 SOUTH	32 EAST, N.M.P.M.		240'	SOUTH	1644'	EAST	LEA

Bottom Hole Location If Different From Surface

UL or lot no.	Section	Township	Range	Lot (ch)	Feet from the	North South line	Feet from the	East West line	County
B	8	24 SOUTH	32 EAST, N.M.P.M.		780' 797'	NORTH	2203' 2368'	EAST	LEA

Dedicated Acres: **320** Joint or Infill: **Y** Consolidation Code: _____ Order No.: **BP- 362 FNL 2368 FEL**
TP- 337 FSL 2180 FEL

No allowable will be assigned to this completion until all interests have been consolidated or a non-standard unit has been approved by the division.

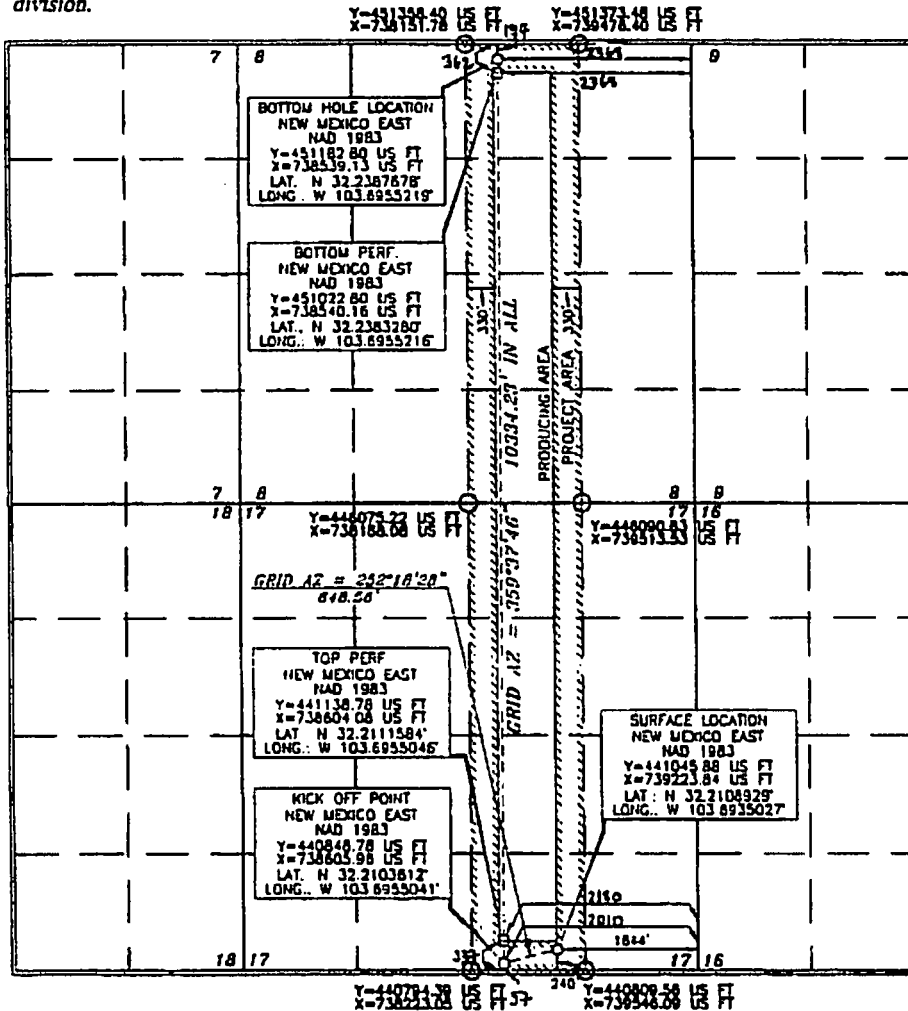

OPERATOR CERTIFICATION

I hereby certify that the information contained herein is true and complete to the best of my knowledge and belief, and that this organization either owns a working interest or undivided mineral interest in the land including the proposed bottom hole location or has a right to drill the well at this location pursuant to a contract with an owner of such a mineral or working interest, or to a voluntary pooling agreement or a compulsory pooling order heretofore entered by the division.

[Signature] 7/26/18
Date
Jana Mendiola
Project Name
jana.mendiola@oxy.com
E-mail Address

SURVEYOR CERTIFICATION

I hereby certify that the information shown on this plat was prepared from the records of surveys made by myself under my supervision, and that the same is true and correct to the best of my belief.

TERRY J. ASS
15079
OCTOBER 5, 2016
Date of Survey
Terry J. Ass
Signature and Seal of Professional Surveyor
Certificate Number **15079**

District I
1433 N. French Dr., Hobbs, NM 88240
Phone: (575) 791-6161 Fax: (575) 791-6720
District II
417 S. First St., Artesia, NM 88210
Phone: (575) 748-1253 Fax: (575) 748-9720
District III
1400 Rio Grande Road, Aztec, NM 87410
Phone: (505) 334-6173 Fax: (505) 334-6170
District IV
1220 E. St. Francis Dr., Santa Fe, NM 87501
Phone: (505) 476-3461 Fax: (505) 476-3462

State of New Mexico
Energy, Minerals & Natural Resources Department
OIL CONSERVATION DIVISION
1220 South St. Francis Dr.
Santa Fe, NM 87505

Form C-102
Revised August 1, 2011
Submit one copy to appropriate
District Office

AMENDED REPORT
(As-Drilled Plat.)

WELL LOCATION AND ACREAGE DEDICATION PLAT

API Number 30-025-44064	Pool Code 96229	Pool Name Mesa Verde Bone Spring
Property Code 320828	Property Name MESA VERDE BS Unit	Well Number 4H
OGRID No. 16696	Operator Name OXY USA INC.	Elevation 3560 5'

Surface Location

UL or lot no	Section	Township	Range	Lot Idn	Feet from the	North South line	Feet from the	East West line	County
P	17	24 SOUTH	32 EAST, N.M.P.M.		280'	SOUTH	965'	EAST	LEA

Bottom Hole Location if Different From Surface

UL or lot no	Section	Township	Range	Lot Idn	Feet from the	North South line	Feet from the	East West line	County
A	B	24 SOUTH	32 EAST, N.M.P.M.		185	NORTH	512	EAST	LEA
Dedicated Acres 320	Joint or Infill 4	Consolidation Code	Order No.	Bottom Perf: 349' FNL of 508' FEL Top Perf: 343' FSL of 442' FEL					

No allowable will be assigned to this completion until all interests have been consolidated or a non-standard unit has been approved by the division.

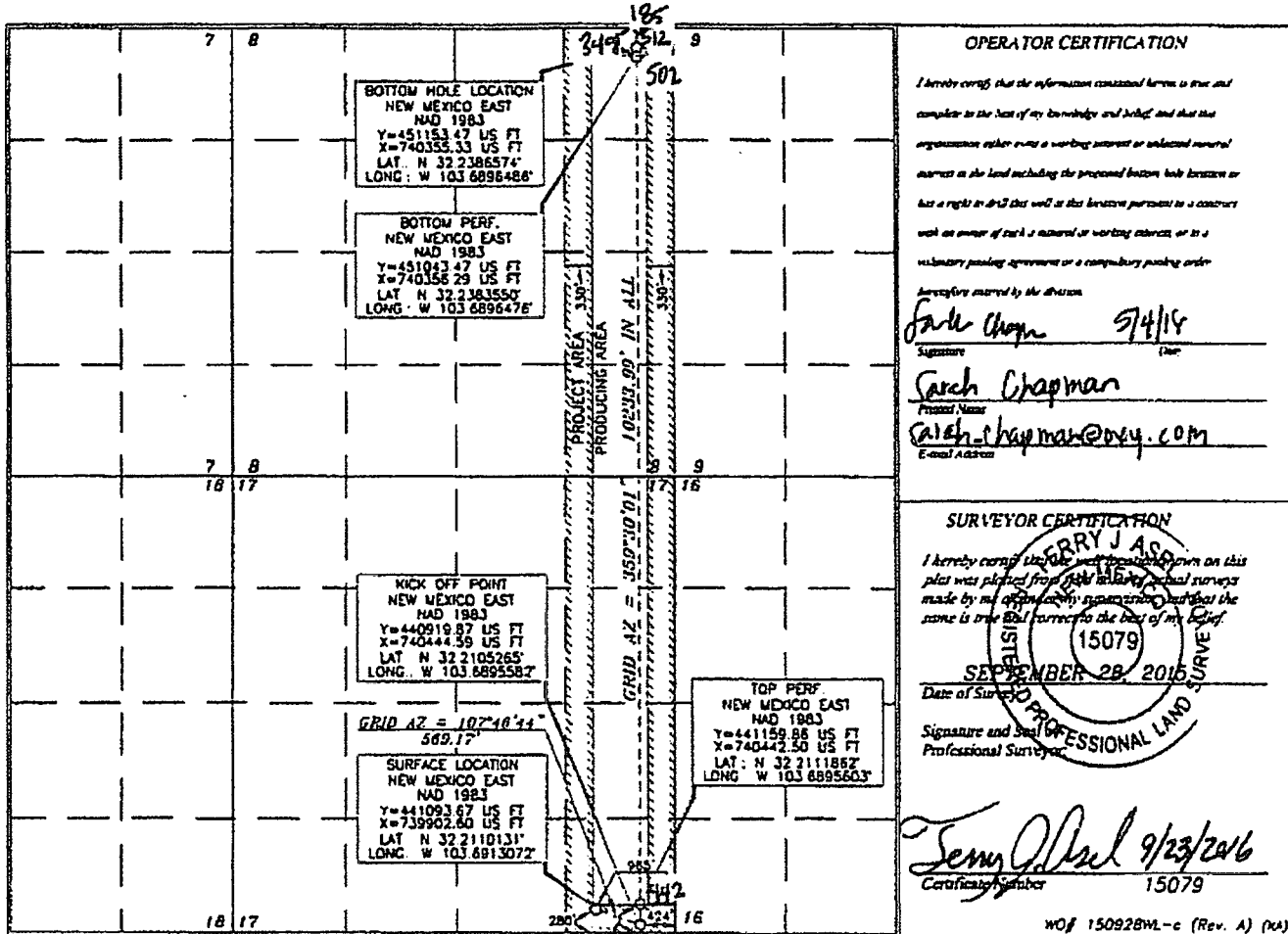

OPERATOR CERTIFICATION
I hereby certify that the information contained herein is true and complete to the best of my knowledge and belief and that the organization either owns a working interest or undivided mineral interest in the land including the proposed bottom hole location or has a right to drill this well at this location pursuant to a contract with the owner of such a mineral or working interest or to a voluntary pooling agreement or a compulsory pooling order.
Authorized by the division
Jack Chapman 9/4/14
Signature
Jack Chapman
Printed Name
jack.chapman@oxy.com
E-mail Address

SURVEYOR CERTIFICATION
I hereby certify that the well location shown on this plat was plotted from first order or second order surveys made by me or my assistants, and that the same is true and correct to the best of my belief.
FERRY J. ASH
15079
SEPTEMBER 28, 2016
Date of Survey
Ferry J. Ash
Signature and Seal of Professional Land Surveyor
Certificate Number **15079**
WOF 150928WL-c (Rev. A) (NA)

District I
1625 N. French Dr., Hobbs, NM 88240
Phone: (575) 393-6161 Fax: (575) 393-0720
District II
111 S. First St., Artesia, NM 88210
Phone: (575) 746-1283 Fax: (575) 748-9720
District III
1000 Rio Brazos Road, Aztec, NM 87410
Phone: (505) 334-6178 Fax: (505) 334-6170
District IV
1220 S. St. Francis Dr., Santa Fe, NM 87505
Phone: (505) 476-3460 Fax: (505) 476-3462

State of New Mexico
Energy, Minerals & Natural Resources Department
OIL CONSERVATION DIVISION
1220 South St. Francis Dr.
Santa Fe, NM 87505

Form C-102
Revised August 1, 2011
Submit one copy to appropriate
District Office

AMENDED REPORT
(As-Drilled)

WELL LOCATION AND ACREAGE DEDICATION PLAT

API Number 30-025-44185	Pool Code 96229	Pool Name Mesa Verde Bone Spring
Property Code 320828	Property Name MESA VERDE BONE SPRING UNIT	Well Number 5H
OGRID No. 16696	Operator Name OXY USA INC.	Elevation 3560.5'

Surface Location

UL or lot no.	Section	Township	Range	Lot Idn	Feet from the	North/South line	Feet from the	East/West line	County
P	17	24 SOUTH	32 EAST, N.M.P.M.		280'	SOUTH	995'	EAST	LEA

Bottom Hole Location If Different From Surface

UL or lot no.	Section	Township	Range	Lot Idn	Feet from the	North/South line	Feet from the	East/West line	County
B	8	24 SOUTH	32 EAST, N.M.P.M.		180' 196'	NORTH	1329' 1329'	EAST	LEA
Dedicated Acres 320	Joint or Infill Y	Consolidation Code	Order No. BP- 358 FNL 1329 FEL (B) TP- 337 FSL 1252 FEL (P)						

No allowable will be assigned to this completion until all interests have been consolidated or a non-standard unit has been approved by the division.

Y=451373.48 US FT X=739478.48 US FT
Y=451388.55 US FT X=740801.22 US FT

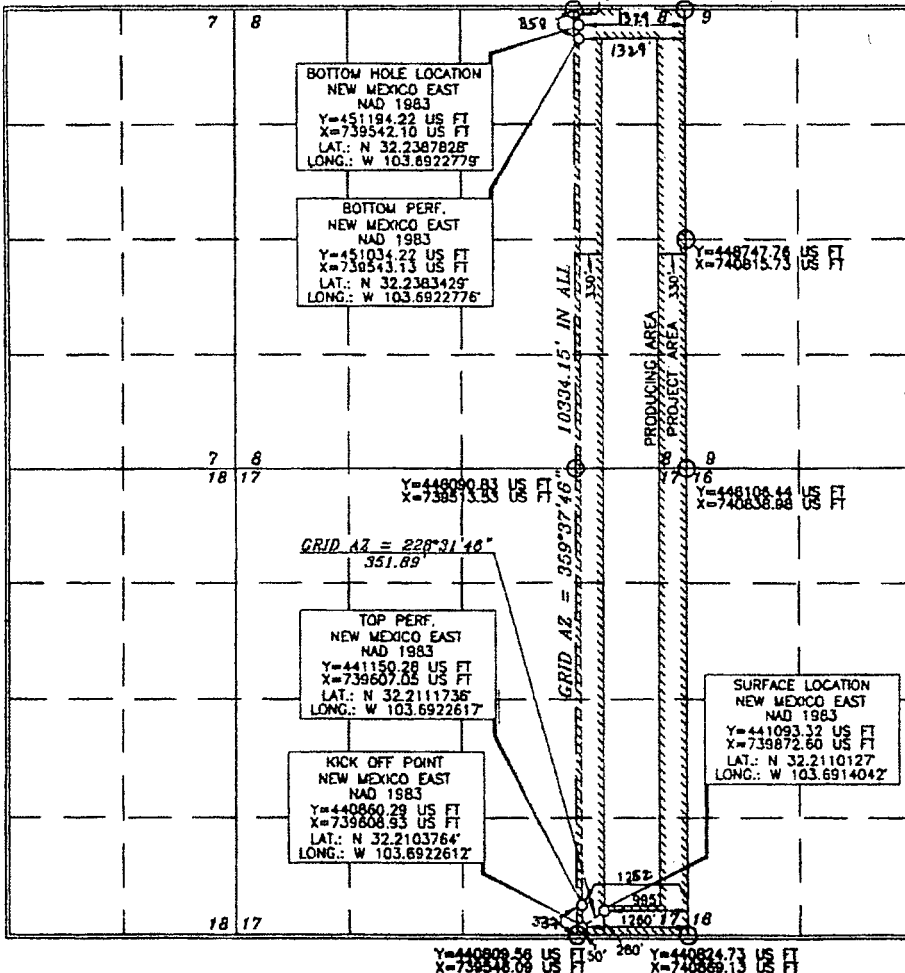

OPERATOR CERTIFICATION
I hereby certify that the information contained herein is true and complete to the best of my knowledge and belief, and that this organization either owns a working interest or mineral interest in the land including the proposed bottom hole location or has a right to drill this well at this location pursuant to a contract with an owner of such a mineral or working interest, or to a voluntary pooling agreement or a compulsory pooling order heretofore entered by the division.
Signature: *Jana Mendiola* Date: **5/8/18**
Printed Name: **Jana Mendiola**
E-mail Address: **jana@oxy.com**

SURVEYOR CERTIFICATION
I hereby certify that the well location shown on this plat was plotted from the best records of actual surveys made by me or under my supervision, and that the same is true and correct to the best of my belief.
Date of Survey: **SEPTEMBER 26, 2018**
Signature and Seal: *Terry J. ASE*
Professional Surveyor: **15079**
Certificate Number: **15079**
Date: **9/29/2016**

WOJ 150926WL-b-XY (Rev A) (KA)

District I
1623 N. French Dr., Hobbs, NM 88240
Phone: (575) 393-6161 Fax: (575) 393-0720
District II
611 S. First St., Artesia, NM 88210
Phone: (575) 748-1283 Fax: (575) 748-9720
District III
1000 Rio Brazos Road, Artesia, NM 87410
Phone: (505) 334-6178 Fax: (505) 334-6170
District IV
1220 S. St. Francis Dr., Santa Fe, NM 87505
Phone: (505) 476-3460 Fax: (505) 476-3462

State of New Mexico
Energy, Minerals & Natural Resources Department
OIL CONSERVATION DIVISION
1220 South St. Francis Dr.
Santa Fe, NM 87505

Form C-102
Revised August 1, 2011
Submit one copy to appropriate
District Office

AMENDED REPORT
(As-drilled)

WELL LOCATION AND ACREAGE DEDICATION PLAT

API Number 30-02S-44042	Pool Code 96229	Pool Name Mesa Verde ; Bone Spring
Property Code 319616	Property Name MESA VERDE "17-8" FEDERAL COM BS Unit	Well Number 44611
OGRID No. 16696	Operator Name OXY USA INC.	Elevation 3559.6'

Surface Location

UL or lot no.	Section	Township	Range	Lot Idn	Feet from the	North/South line	Feet from the	East/West line	County
0	17	24 SOUTH	32 EAST, N.M.P.M.		280'	SOUTH	2624'	EAST	LEA

Bottom Hole Location If Different From Surface

UL or lot no.	Section	Township	Range	Lot Idn	Feet from the	North/South line	Feet from the	East/West line	County
B	B	24 SOUTH	32 EAST, N.M.P.M.		230' 306'	NORTH	2207' 2292'	EAST	LEA
Dedicated Acres 320	Joint or Infill Y	Consolidation Code	Order No.	FTP: 647' FSL 2210' FEL LTP: 437' FNL 2290' FEL					

No allowable will be assigned to this completion until all interests have been consolidated or a non-standard unit has been approved by the division.

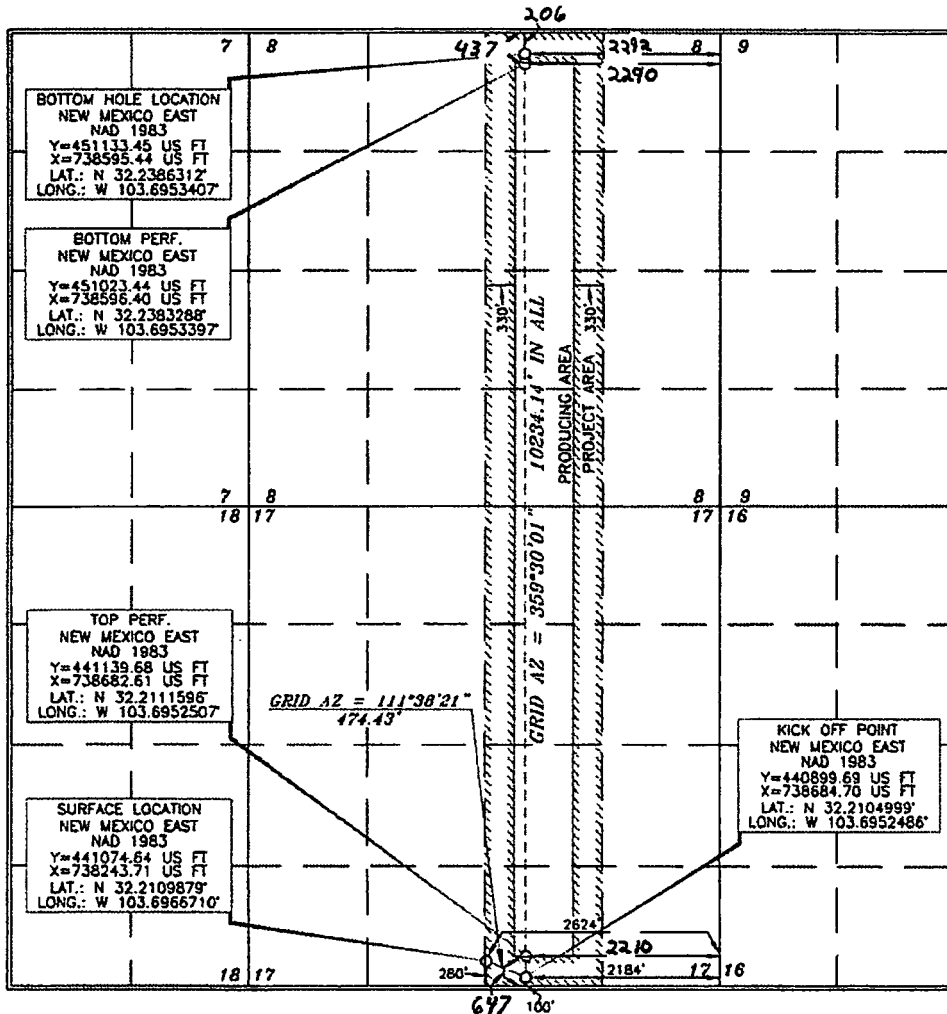

OPERATOR CERTIFICATION

I hereby certify that the information contained herein is true and complete to the best of my knowledge and belief, and that this organization either owns a working interest or undivided mineral interest in the land including the proposed bottom hole location or has a right to drill this well at this location pursuant to a contract with an owner of such a mineral or working interest, or to a voluntary pooling agreement or a compulsory pooling order heretofore entered by the division.

Signature: Justin Morris Date: 8/8/18
Printed Name: Justin Morris
E-mail Address: Justin_Morris@oxy.com

SURVEYOR CERTIFICATION

I hereby certify that the well location shown on this plat was plotted from the original surveys made by me or under my supervision, and that the same is true and correct to the best of my belief.

Date of Survey: SEPTEMBER 28, 2018
Signature and Seal: Terry J. As...
Professional Surveyor

Signature: Terry J. As... Certificate Number: 15079

Side 2

PERF

Tubing Size: 2-7/8" Lining Material: UNLINED

Type of Packer: ARROWSET PACKER 5.5"

Packer Setting Depth: 9065' MD/8970' TVD

Other Type of Tubing/Casing Seal (if applicable): _____

Additional Data

1. Is this a new well drilled for injection? _____ Yes X _____ No

If no, for what purpose was the well originally drilled? _____
PRODUCER-OIL

2. Name of the Injection Formation: _____

3. Name of Field or Pool (if applicable): [96229] MESA VERDE; BONE SPRING

4. Has the well ever been perforated in any other zone(s)? List all such perforated intervals and give plugging detail, i.e. sacks of cement or plug(s) used. _____
NO

5. Give the name and depths of any oil or gas zones underlying or overlying the proposed injection zone in this area: _____

MV BS #1H CBL

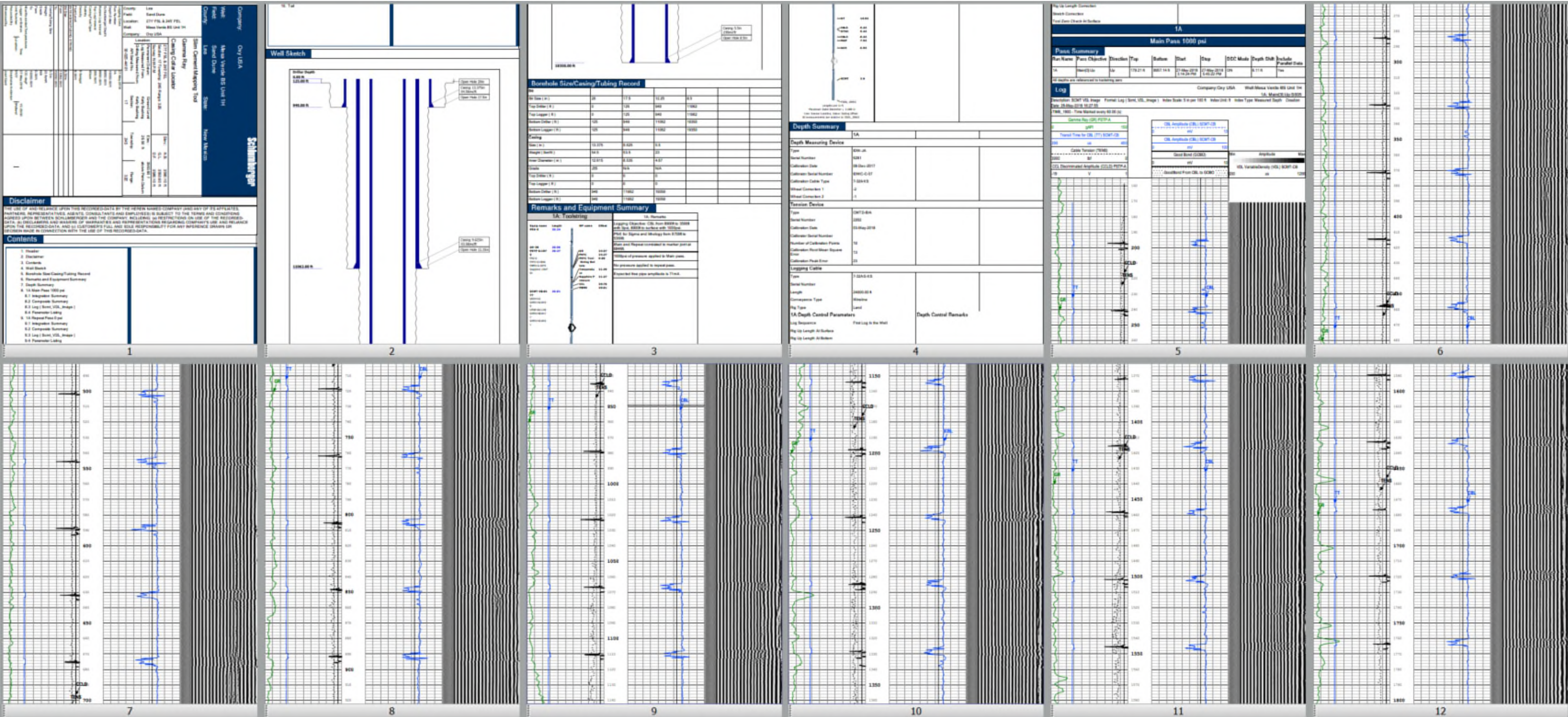

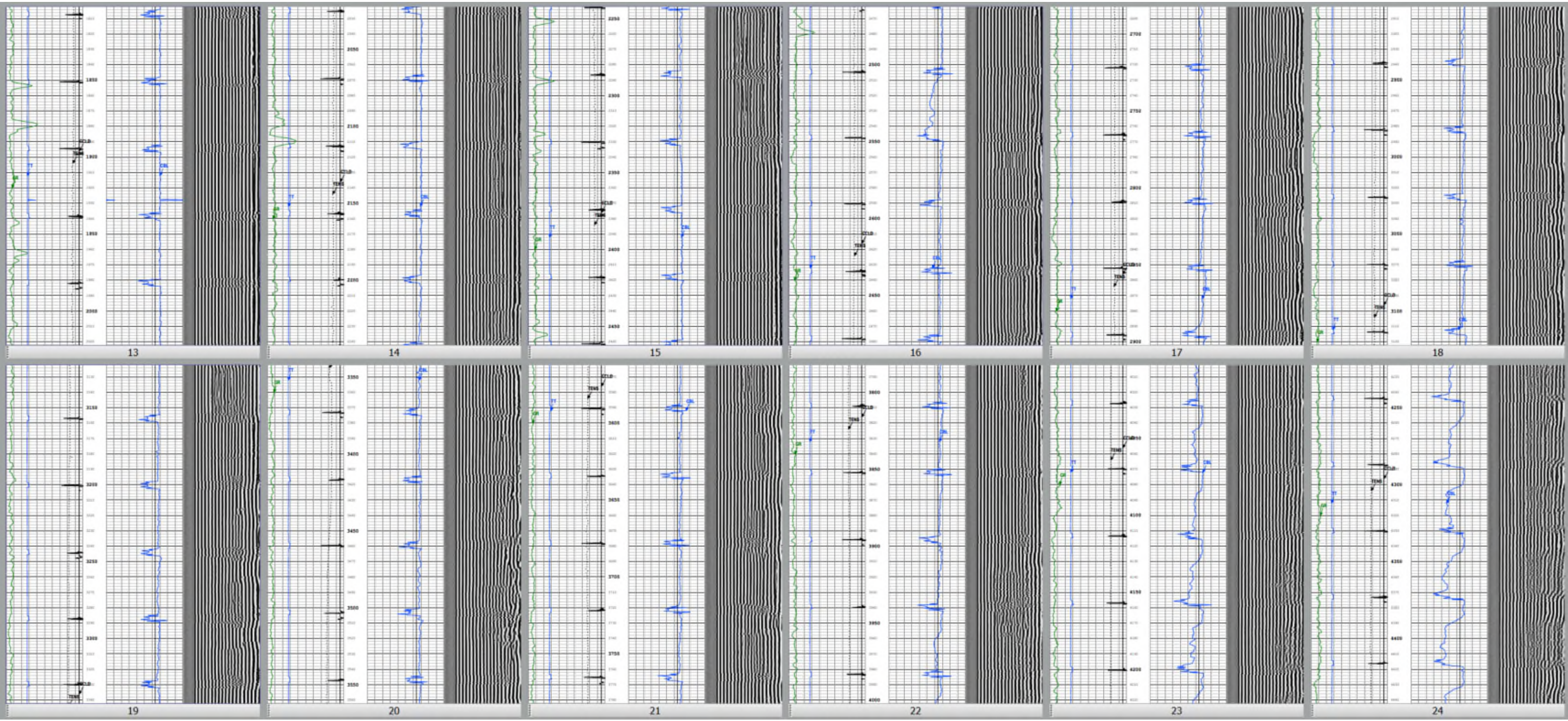

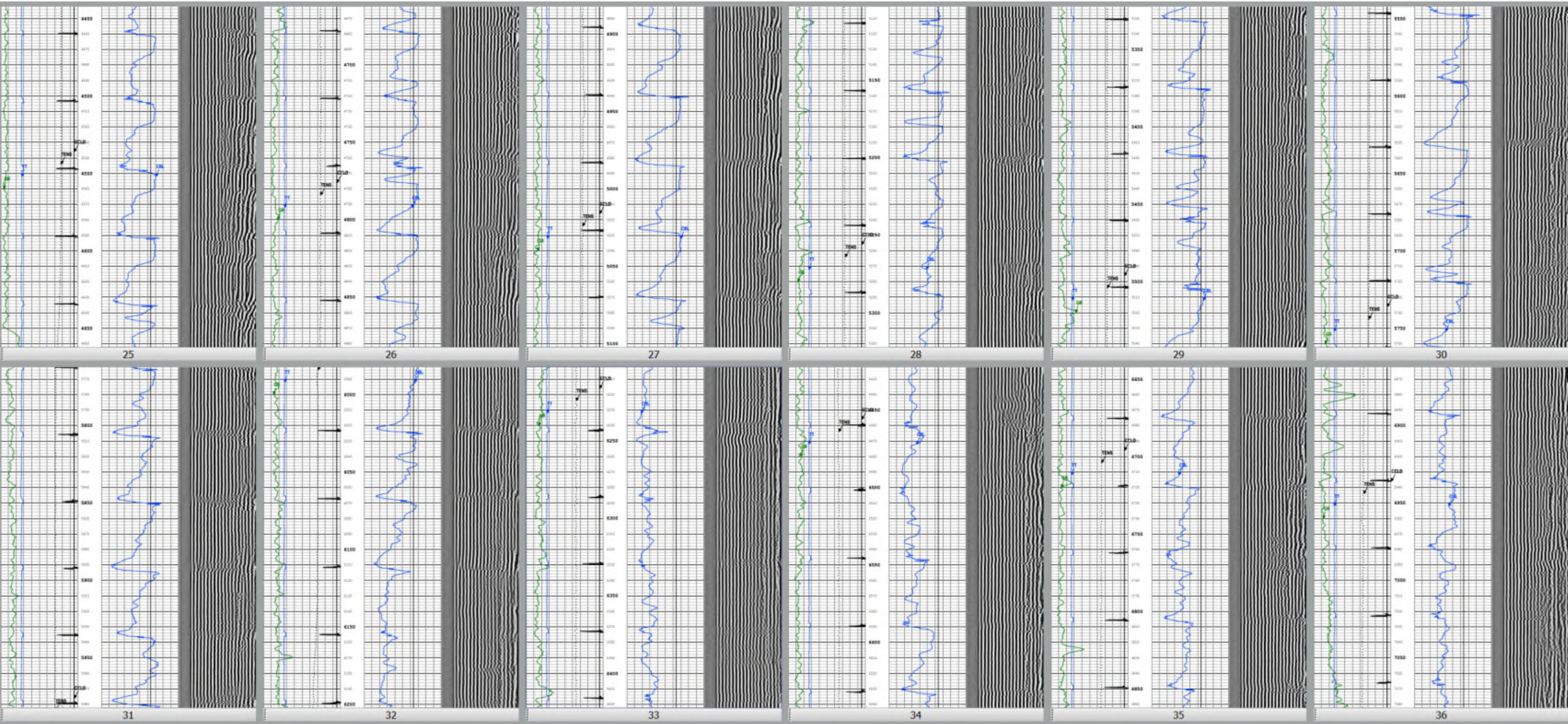

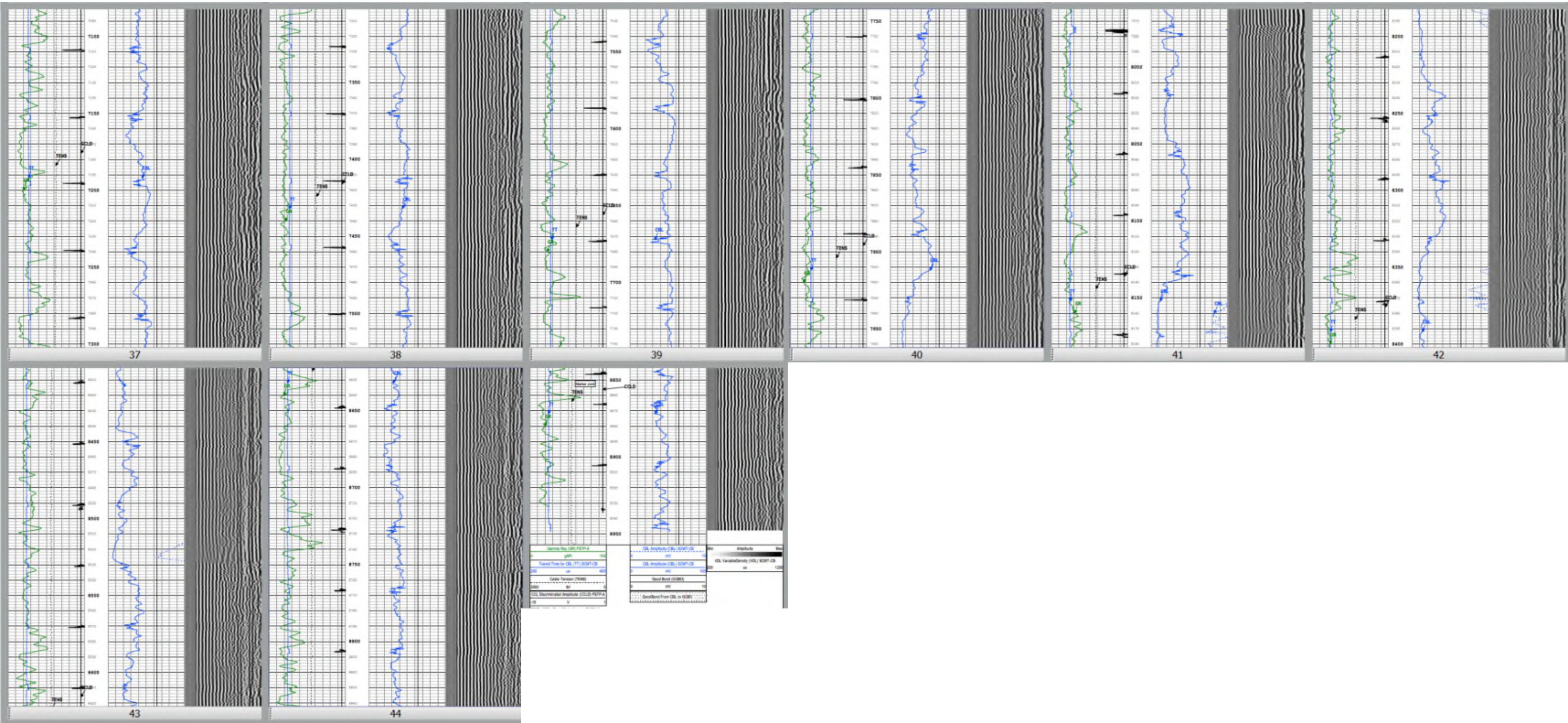

Side 1

OPERATOR: OXY USA INC

WELL NAME & NUMBER: MESA VERDE BONE SPRING UNIT 2H

WELL LOCATION: 240' FSL 1614' FEL O 17 24S 32E
 FOOTAGE LOCATION UNIT LETTER SECTION TOWNSHIP RANGE

WELLBORE SCHEMATIC

WELL CONSTRUCTION DATA
Surface Casing

MESA VERDE BONE SPRING UNIT 2H

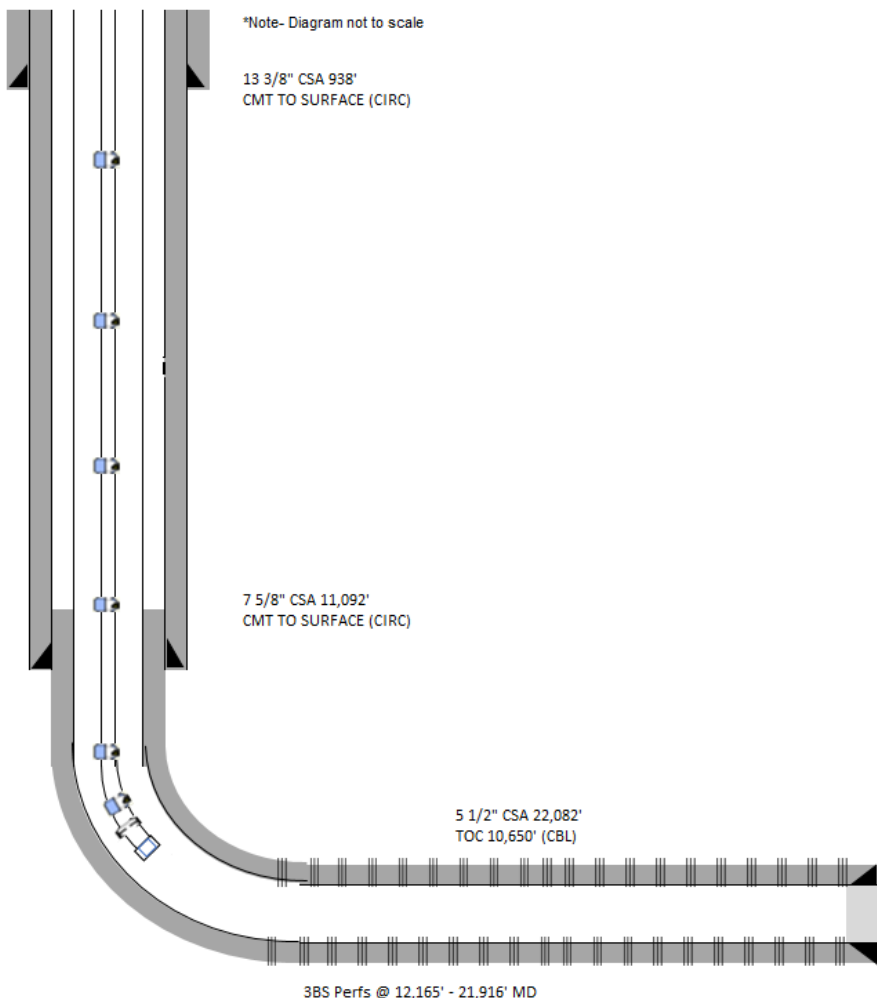

Hole Size: 17.5" Casing Size: 13-3/8"
 Cemented with: 1202 sx. *or* _____ ft³
 Top of Cement: SURFACE Method Determined: CIRC

Intermediate Casing

Hole Size: 9.875" Casing Size: 7-5/8"
 Cemented with: 2624 sx. *or* _____ ft³
 Top of Cement: SURFACE Method Determined: CIRC

Production Casing

Hole Size: 6.75" Casing Size: 5.5"
 Cemented with: 846 sx. *or* _____ ft³
 Top of Cement: 10,650' Method Determined: CBL
 Total Depth: 22,082' MD/11,860' TVD

Injection Interval

12,165' MD/11,815' TVD feet to 21,916' MD/11,860' TVD

(Perforated or Open Hole; indicate which)

Side 2

PERF

Tubing Size: 2-7/8" SET AT 12033' MD/11800' TVD Lining Material: UNLINED

Type of Packer: N/A

Packer Setting Depth: N/A- FOR MIT, SET NOT GREATER THAN 100' ABOVE THE KOP

Other Type of Tubing/Casing Seal (if applicable): _____

Additional Data

1. Is this a new well drilled for injection? _____ Yes X No

If no, for what purpose was the well originally drilled? _____
PRODUCER-OIL

2. Name of the Injection Formation: _____

3. Name of Field or Pool (if applicable): [96229] MESA VERDE; BONE SPRING

4. Has the well ever been perforated in any other zone(s)? List all such perforated intervals and give plugging detail, i.e. sacks of cement or plug(s) used. _____
NO

5. Give the name and depths of any oil or gas zones underlying or overlying the proposed injection zone in this area: _____

MV BS #2H CBL

RENEGADE
Radial Cement Bond
Gamma Ray CCL
Log

Company	Occidental Petroleum, L.P.
Asset	West Texas 02 Unit 851
Well	02-0001
State	New Mexico
County	Lea
City	Marathon
Location	Lea 02-0001-0001
Latitude	32.710000 N
Longitude	-103.521410 W
Country	USA

***** Thank You For Choosing Renegade Services *****
Log is Correlated Back To Marker Joint
Per Casing Tally

RENEGADE
Main Pass (1000 PSI)

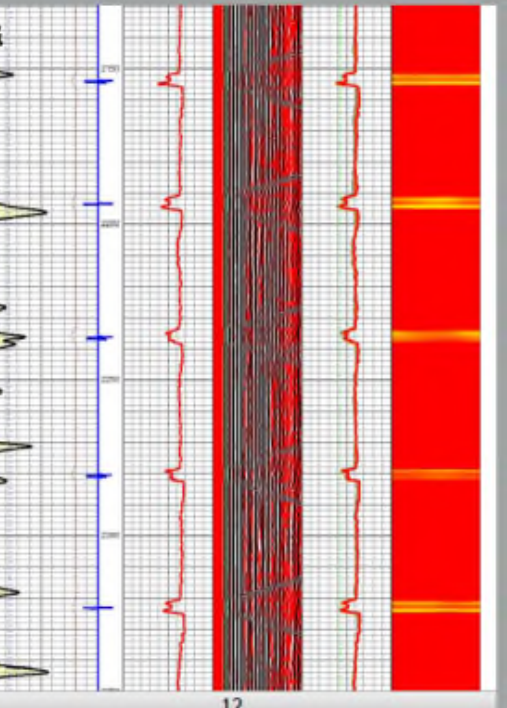
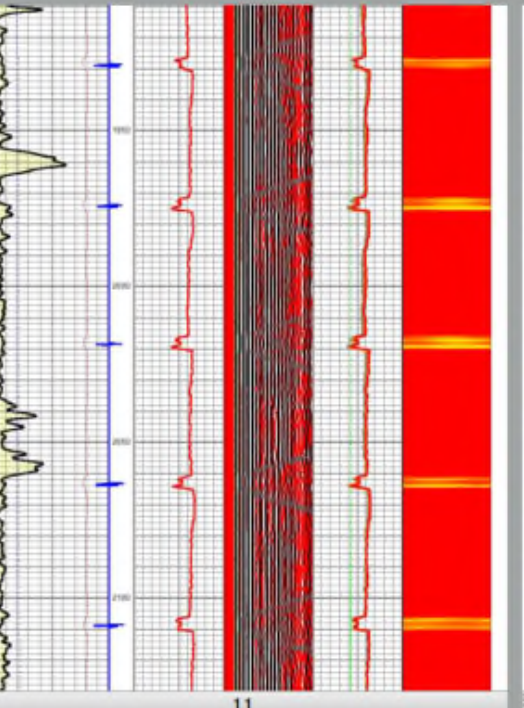
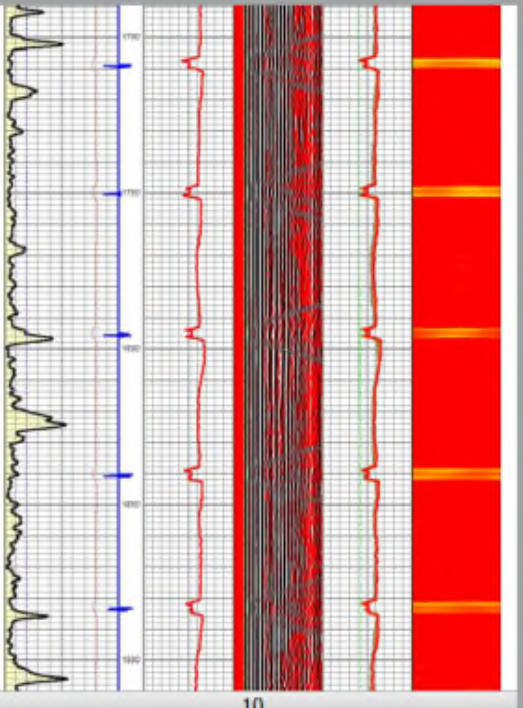
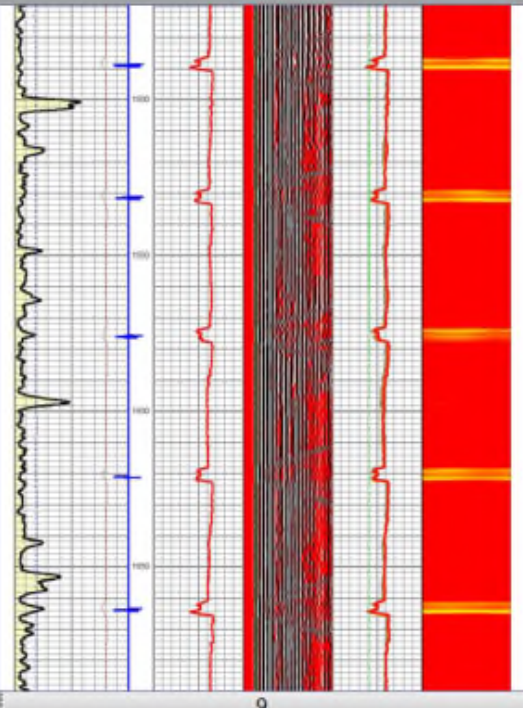
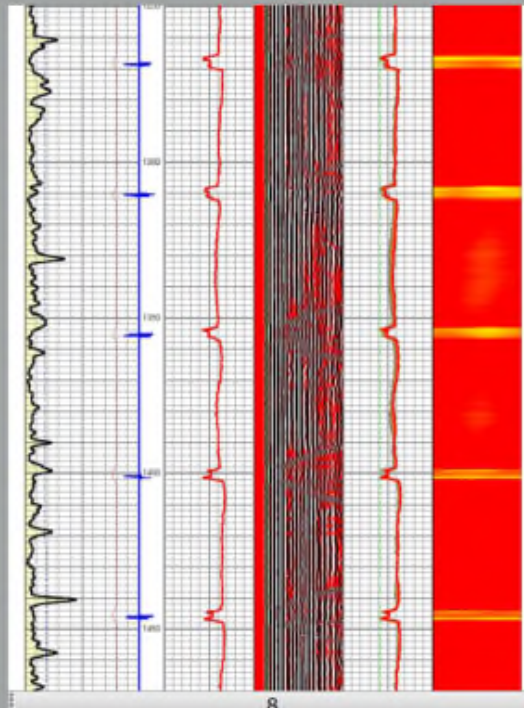
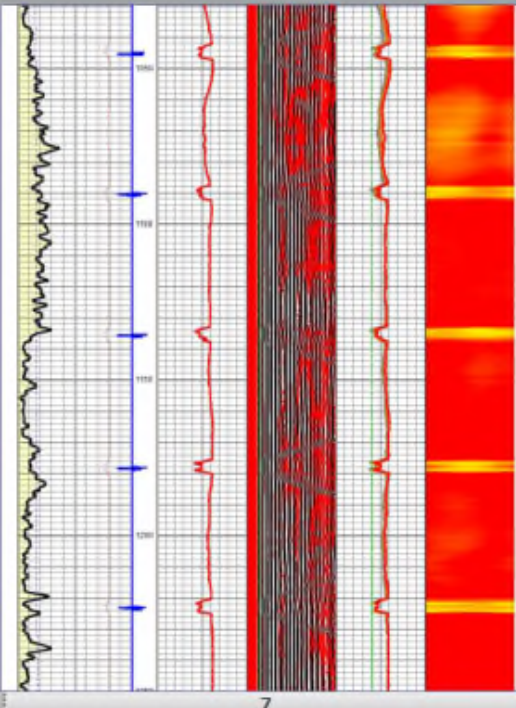
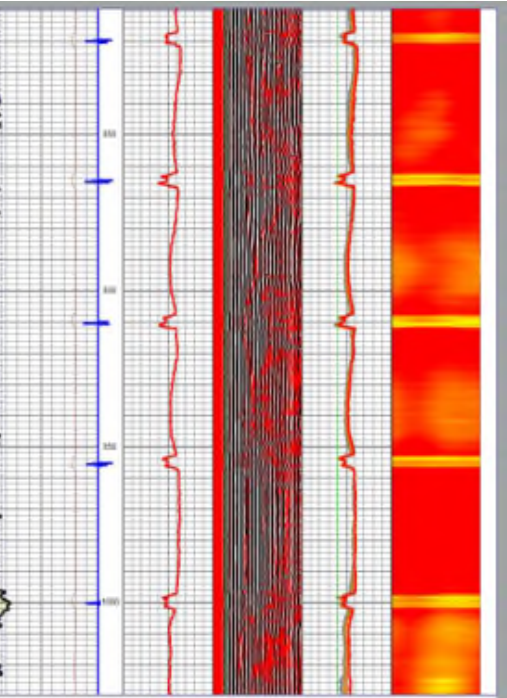
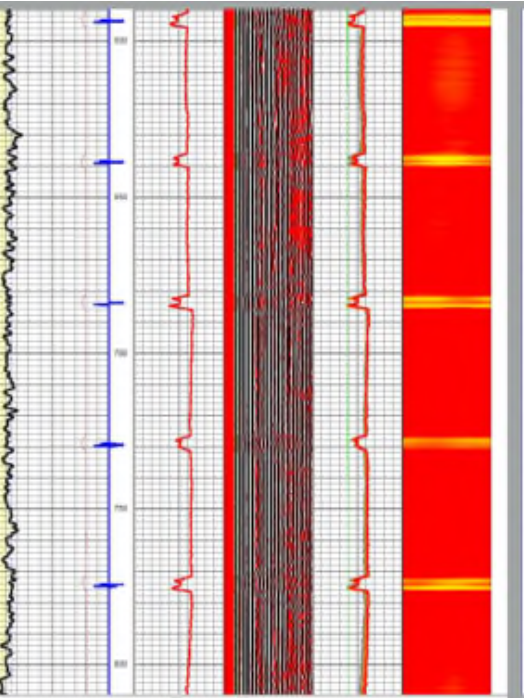
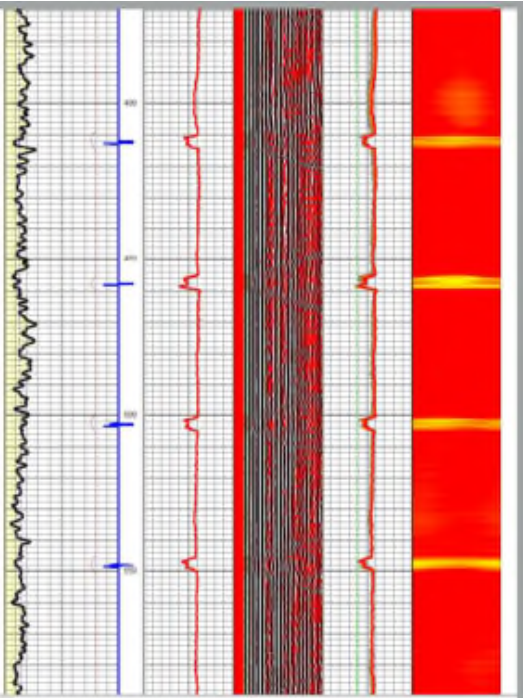
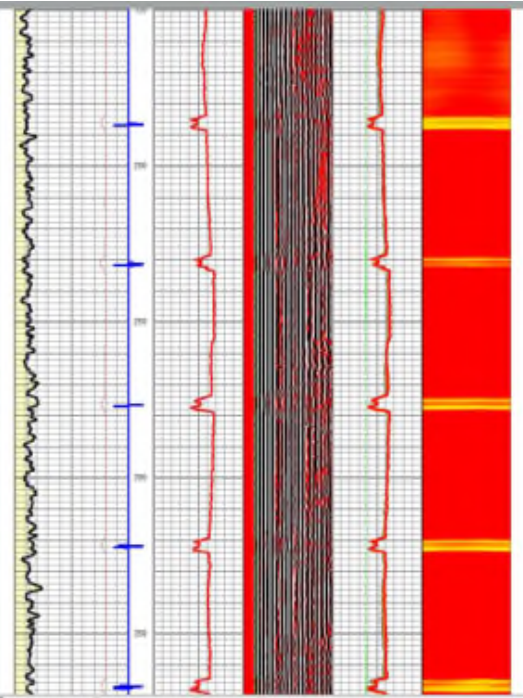
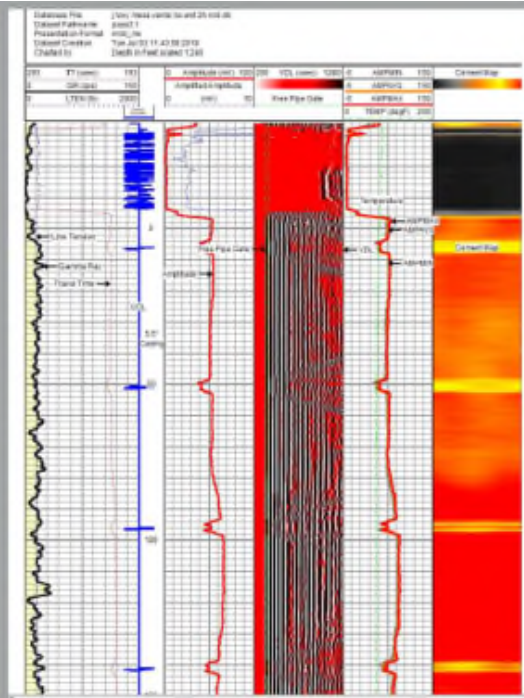

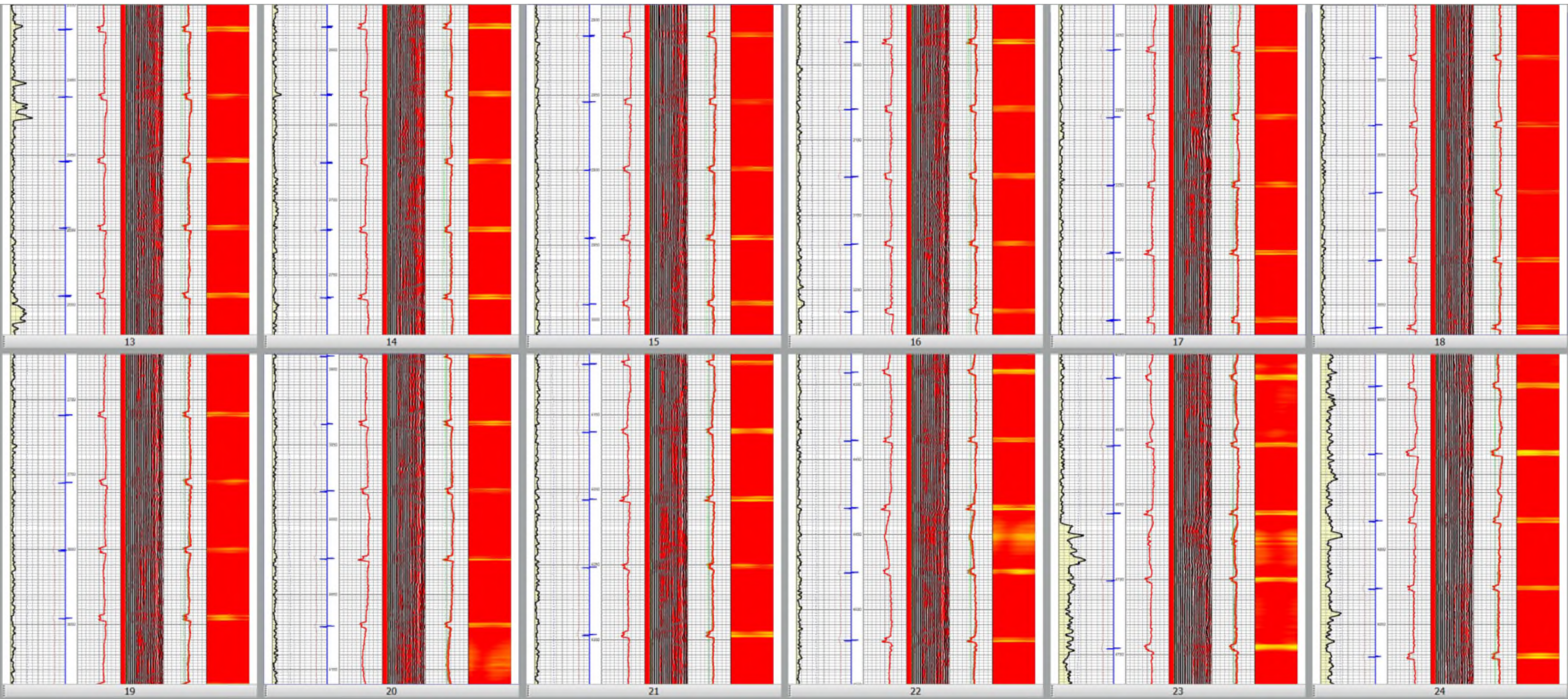

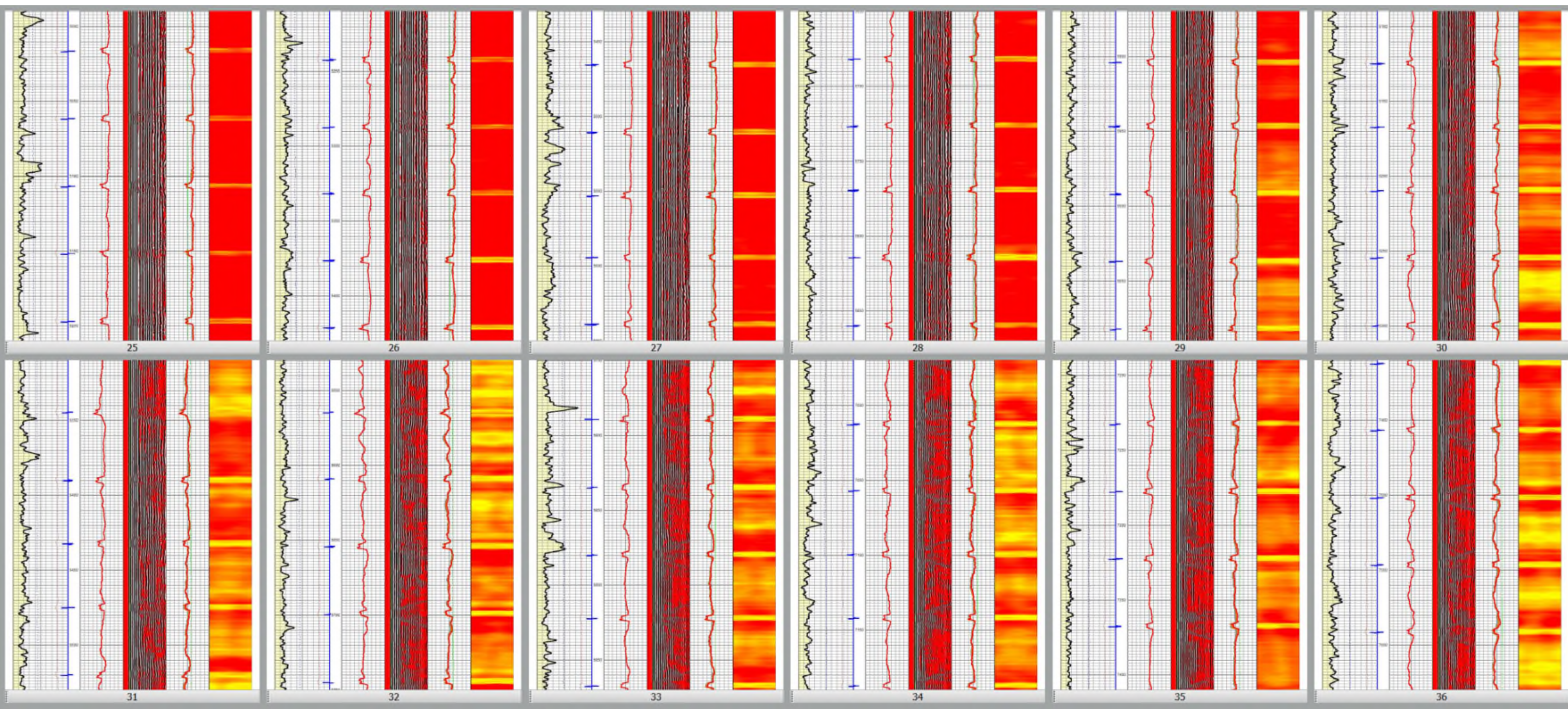

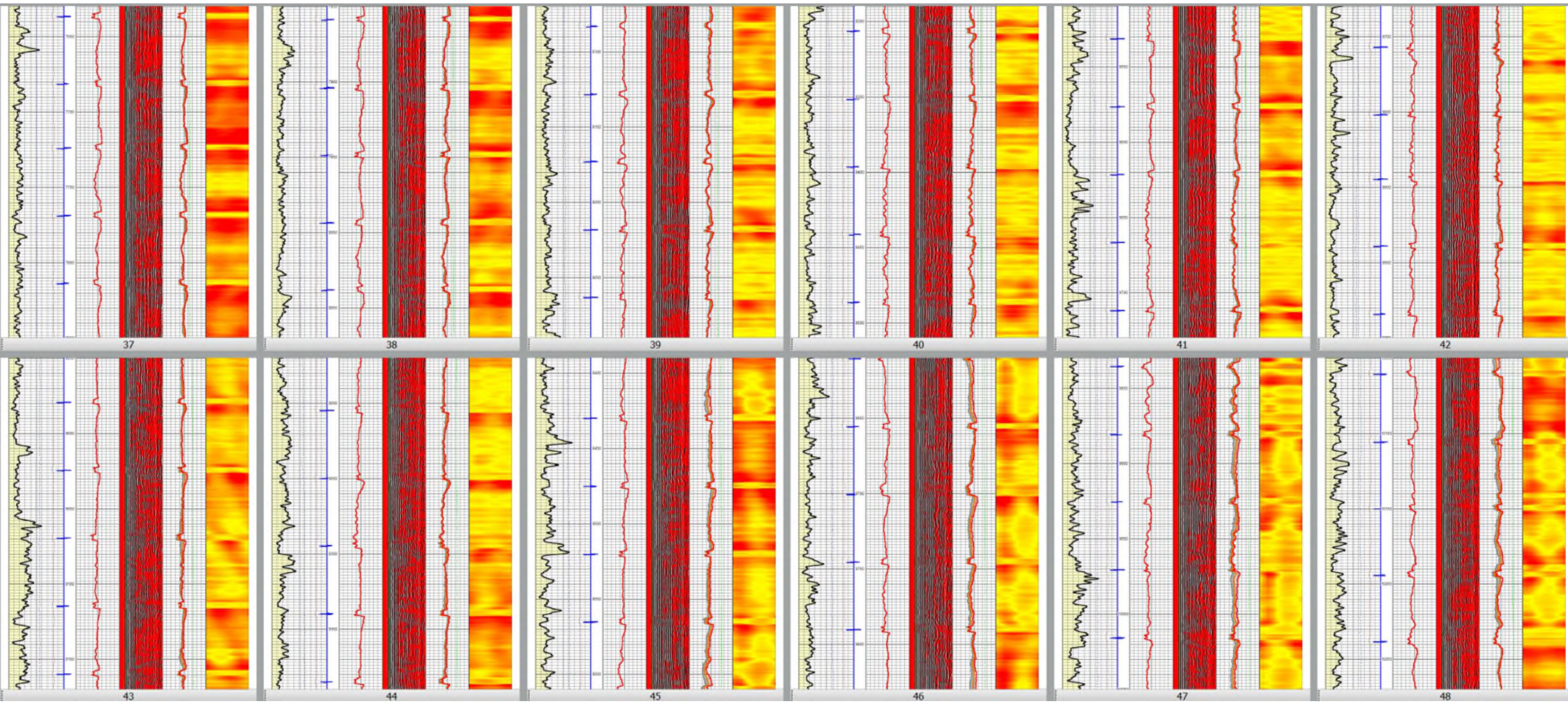

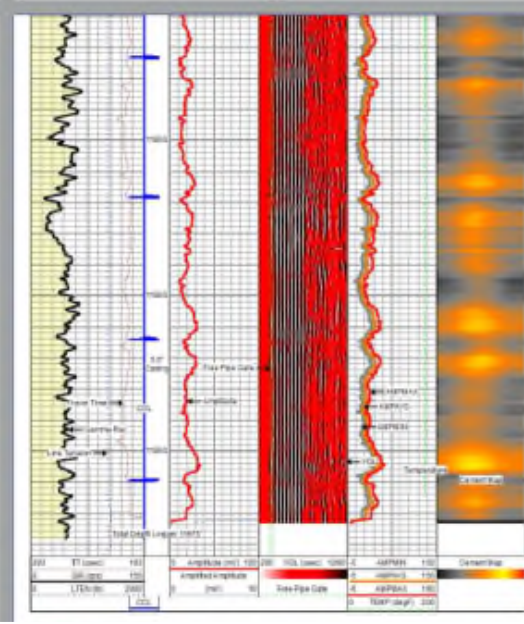
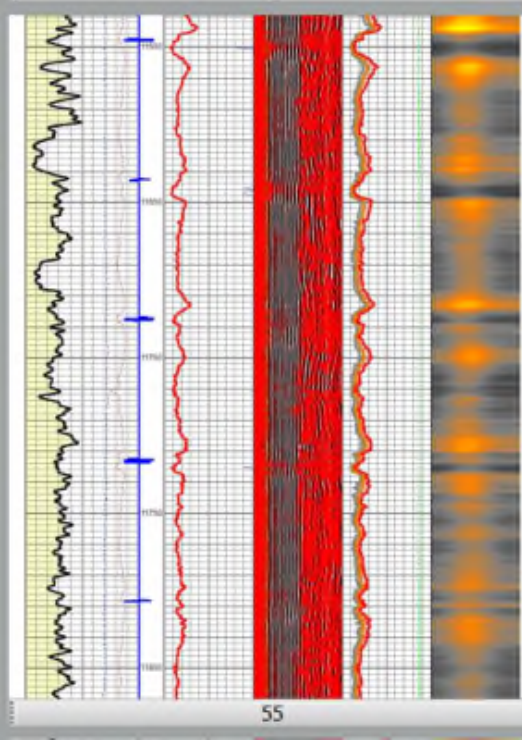
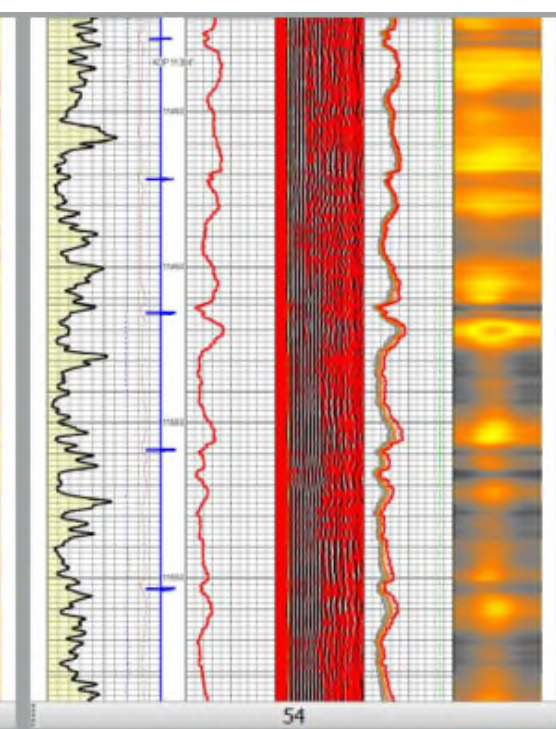
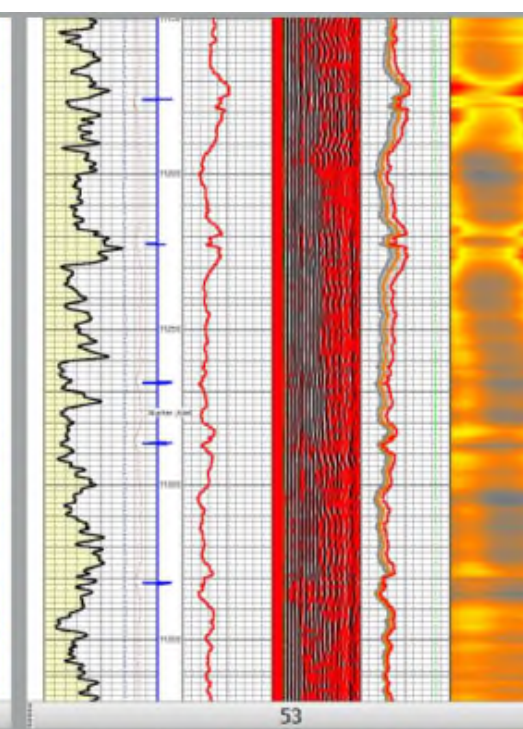
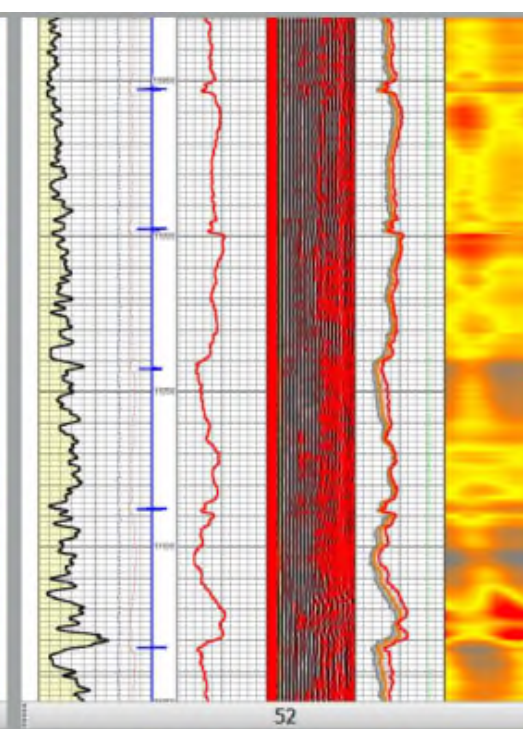
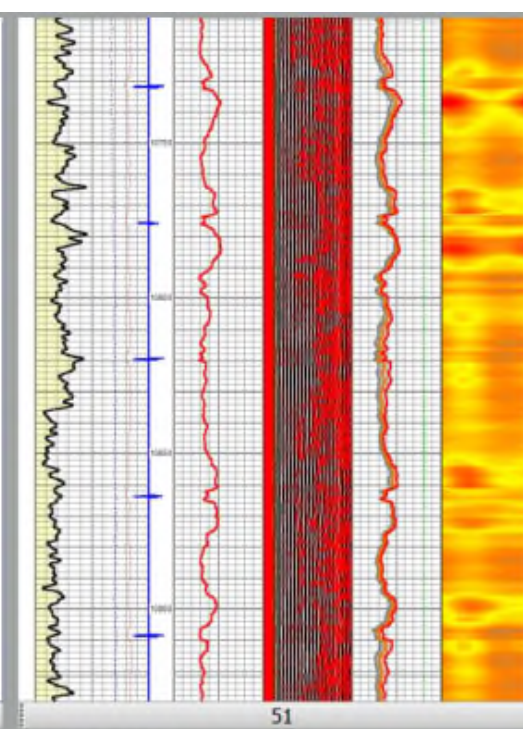
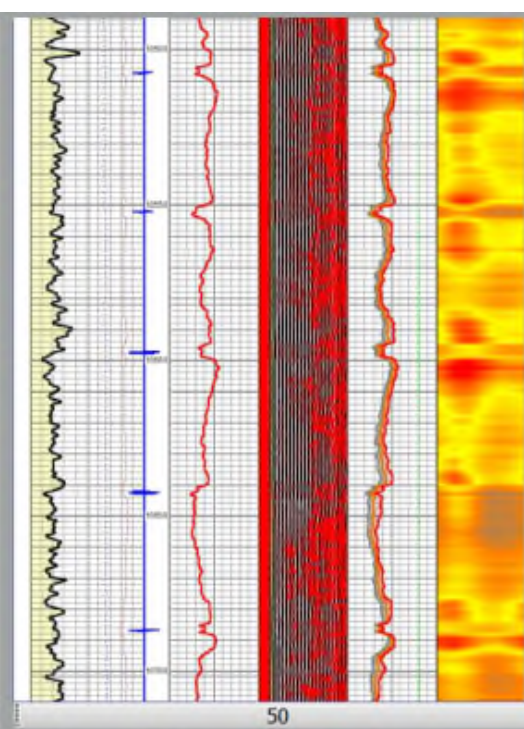
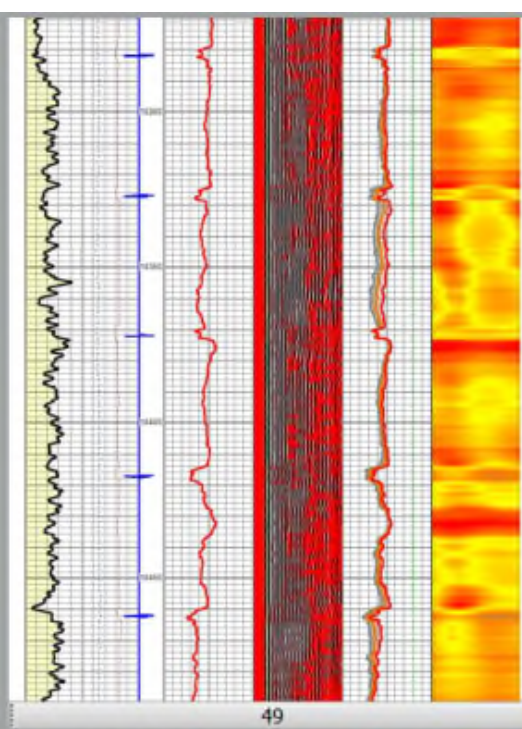

Side 1

OPERATOR: OXY USA INC

WELL NAME & NUMBER: MESA VERDE BONE SPRING UNIT 3H

WELL LOCATION: 240' FSL 1644' FEL O 17 24S 32E
 FOOTAGE LOCATION UNIT LETTER SECTION TOWNSHIP RANGE

WELLBORE SCHEMATIC

WELL CONSTRUCTION DATA
Surface Casing

MESA VERDE BONE SPRING UNIT 3H

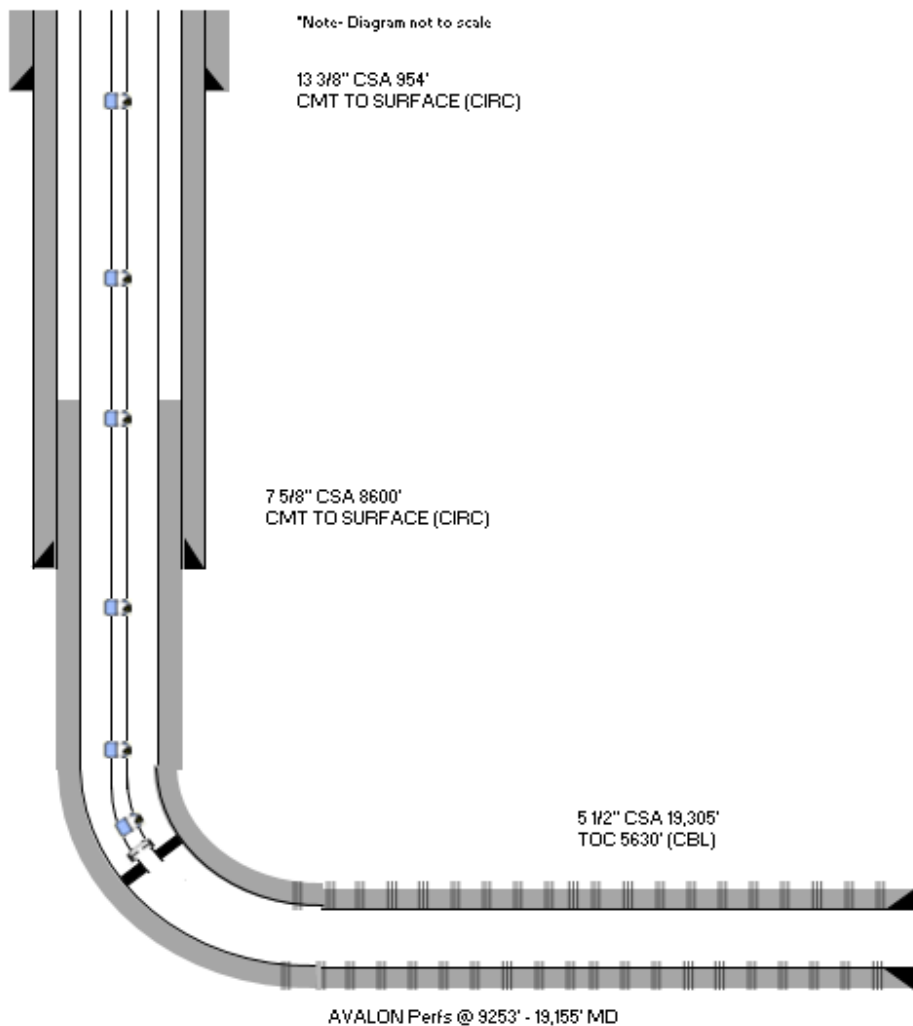

Hole Size: 17.5" Casing Size: 13-3/8"
 Cemented with: 1220 sx. *or* _____ ft³
 Top of Cement: SURFACE Method Determined: CIRC

Intermediate Casing

Hole Size: 9.875" Casing Size: 7-5/8"
 Cemented with: 2399 sx. *or* _____ ft³
 Top of Cement: SURFACE Method Determined: CIRC

Production Casing

Hole Size: 6.75" Casing Size: 5.5"
 Cemented with: 826 sx. *or* _____ ft³
 Top of Cement: 5630' Method Determined: CBL

Total Depth: 19,305' MD/9125' TVD

Injection Interval

9253' MD/9091' TVD feet to 19,155' MD/9126' TVD

(Perforated or Open Hole; indicate which)

Side 2

PERF

Tubing Size: 2-7/8" Lining Material: UNLINED

Type of Packer: WATSON AS1X 10K PACKER 20-23# 5.5"

Packer Setting Depth: 8956' MD/8886' TVD

Other Type of Tubing/Casing Seal (if applicable): _____

Additional Data

1. Is this a new well drilled for injection? _____ Yes X _____ No

If no, for what purpose was the well originally drilled? _____

PRODUCER-OIL

2. Name of the Injection Formation: _____

3. Name of Field or Pool (if applicable): [96229] MESA VERDE; BONE SPRING

4. Has the well ever been perforated in any other zone(s)? List all such perforated intervals and give plugging detail, i.e. sacks of cement or plug(s) used. _____

NO

5. Give the name and depths of any oil or gas zones underlying or overlying the proposed injection zone in this area: _____

MV BS #3H CBL

RENEGADE SERVICES

Radical Cement Bond
Gamma Ray OCL
Log

Company: Occidental Petroleum, LTD.
Well: MESA VENT 35 UNKSH
Field: SAND CREEK
State: NEW MEXICO
Country: USA

Log Date: 07/01/2021
Log Time: 08:00:00
Log Depth: 10000.00
Log Interval: 1.00

***** Thank You For Choosing Renegade Services *****
Log is Renegade Depths Only
* Could Not Reach Marker Joint II is At 85 Degrees *

RENEGADE SERVICES Main Pass (1000 PSI)

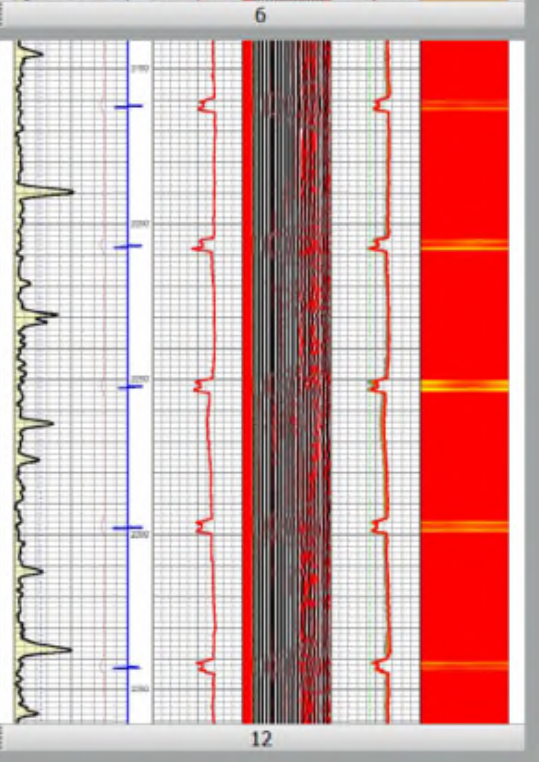
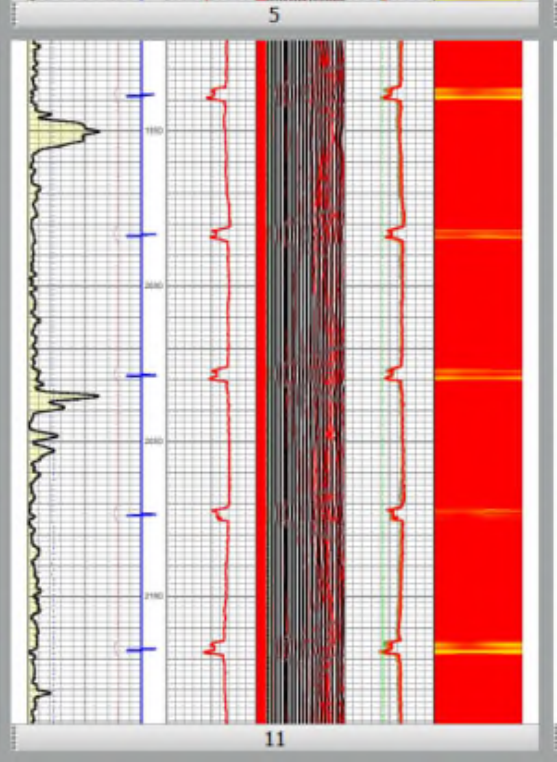
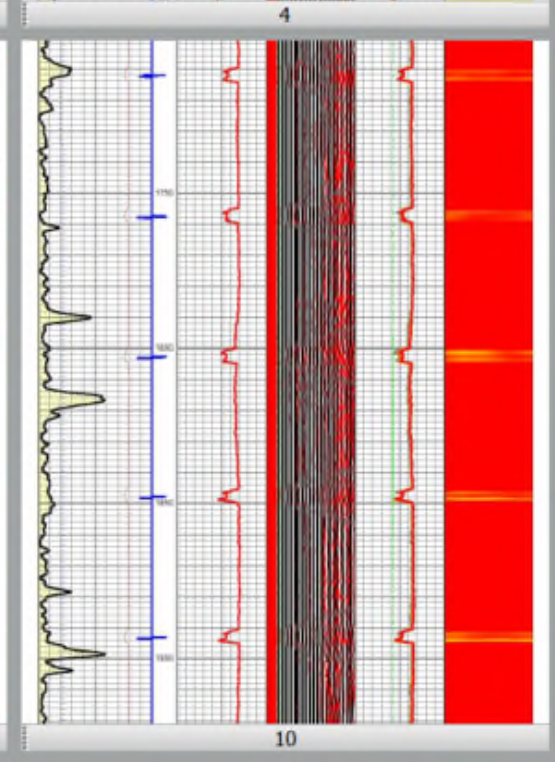
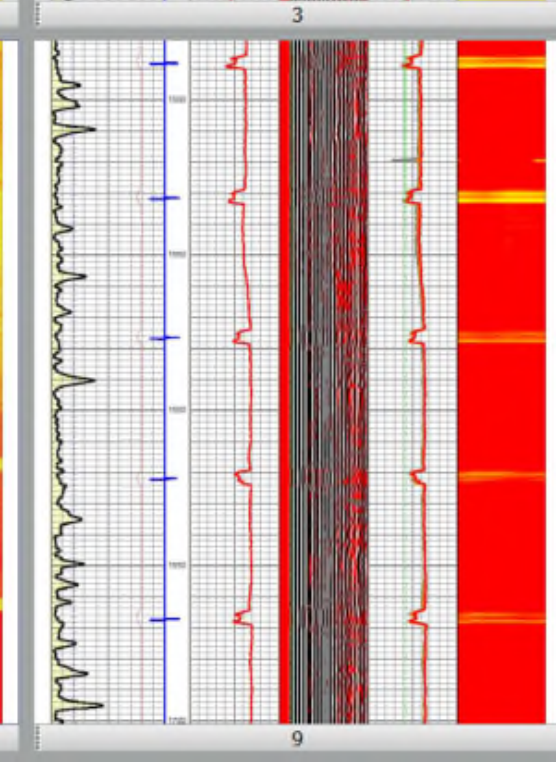
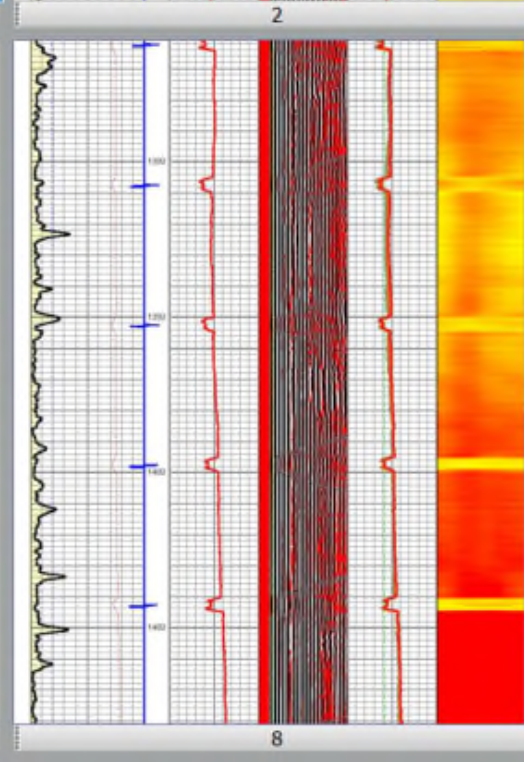
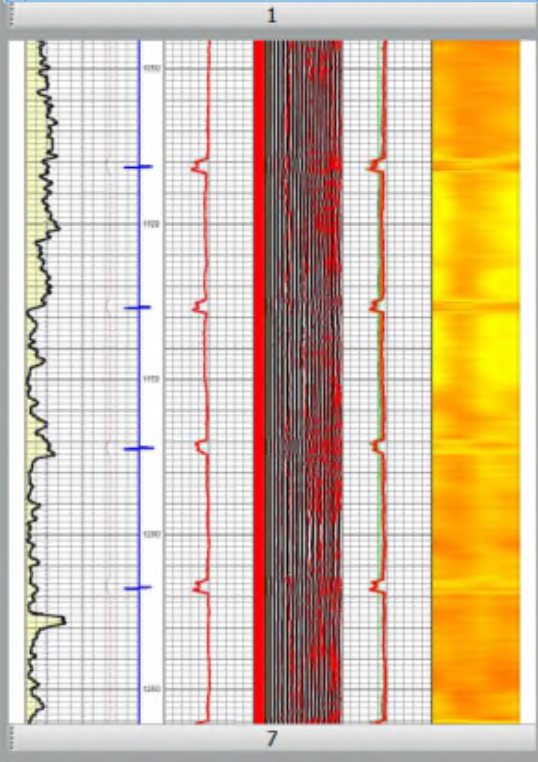
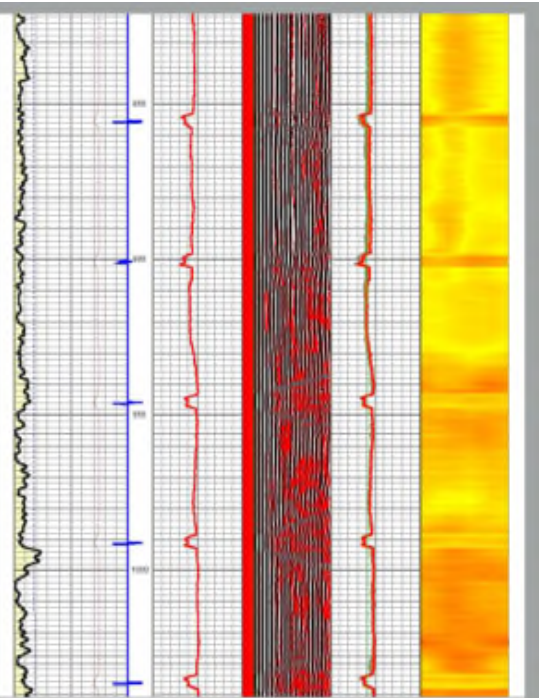
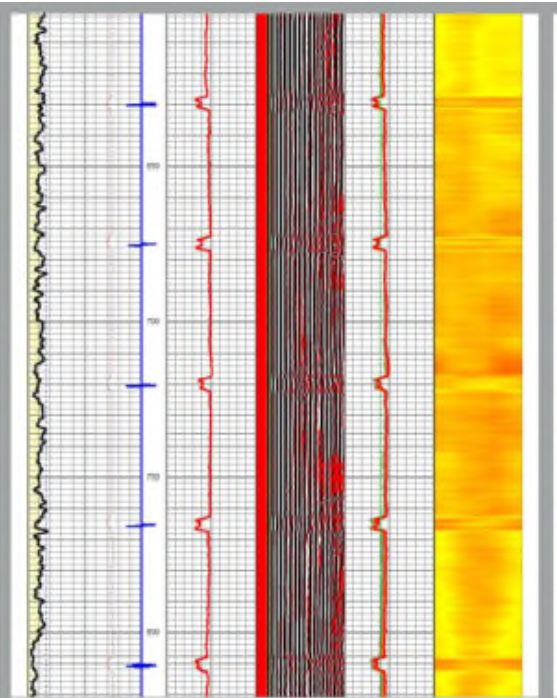
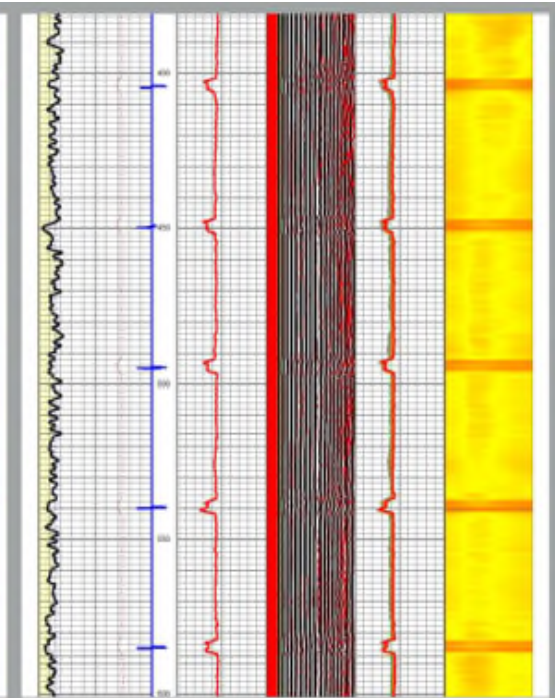
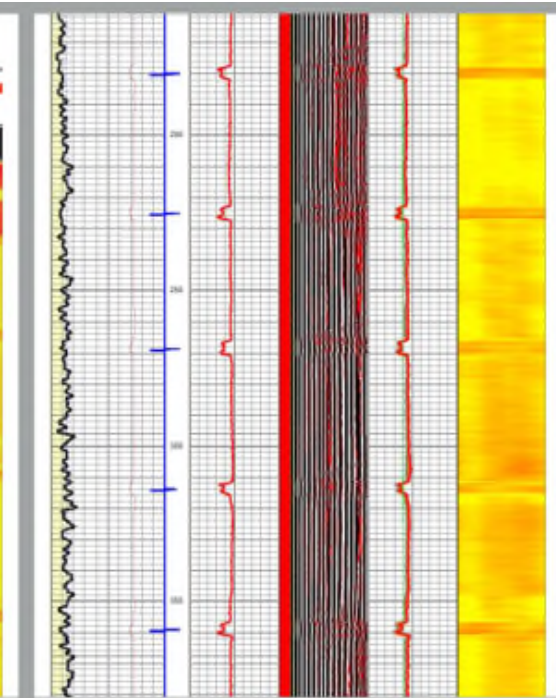
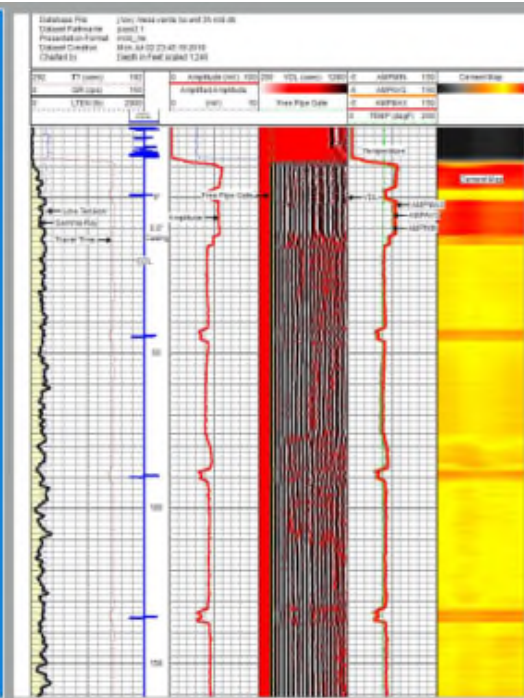

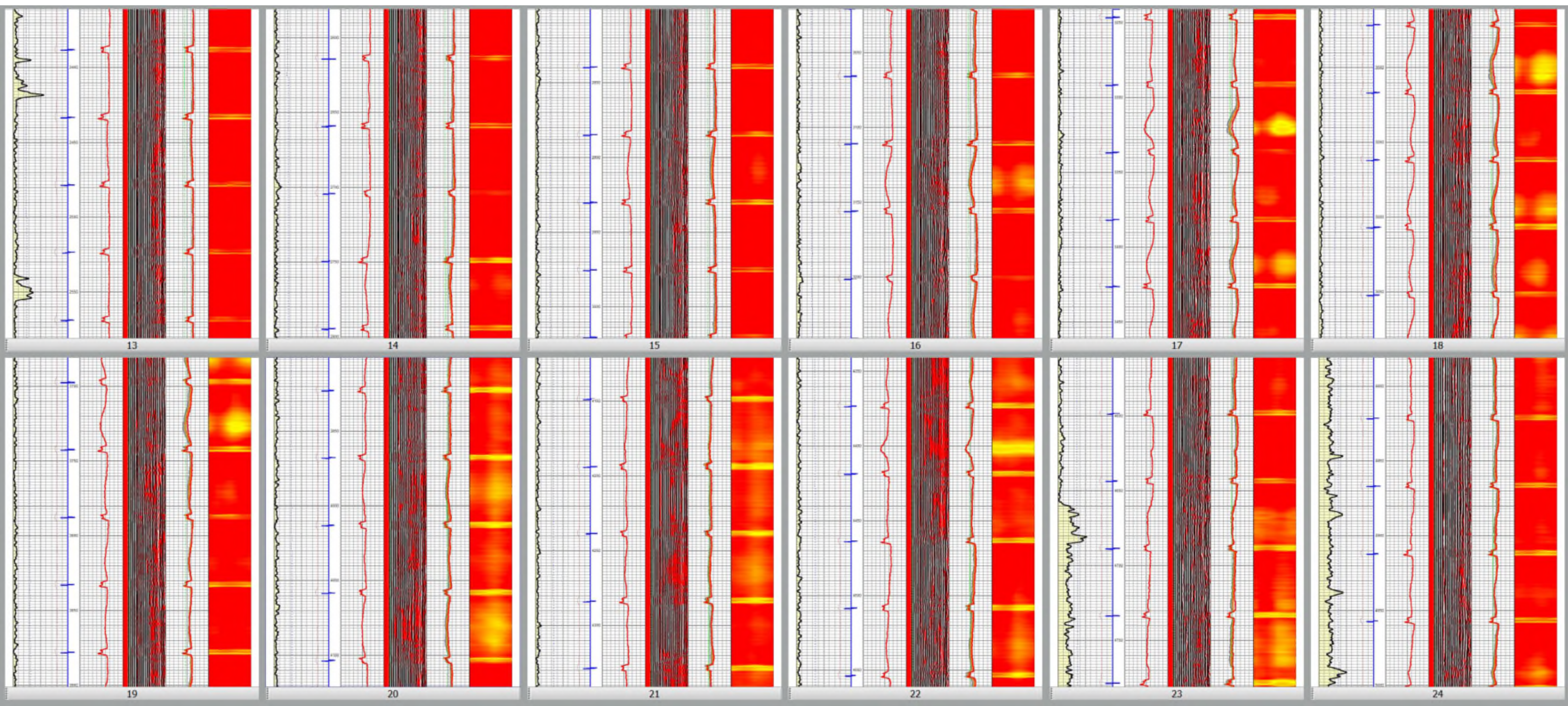

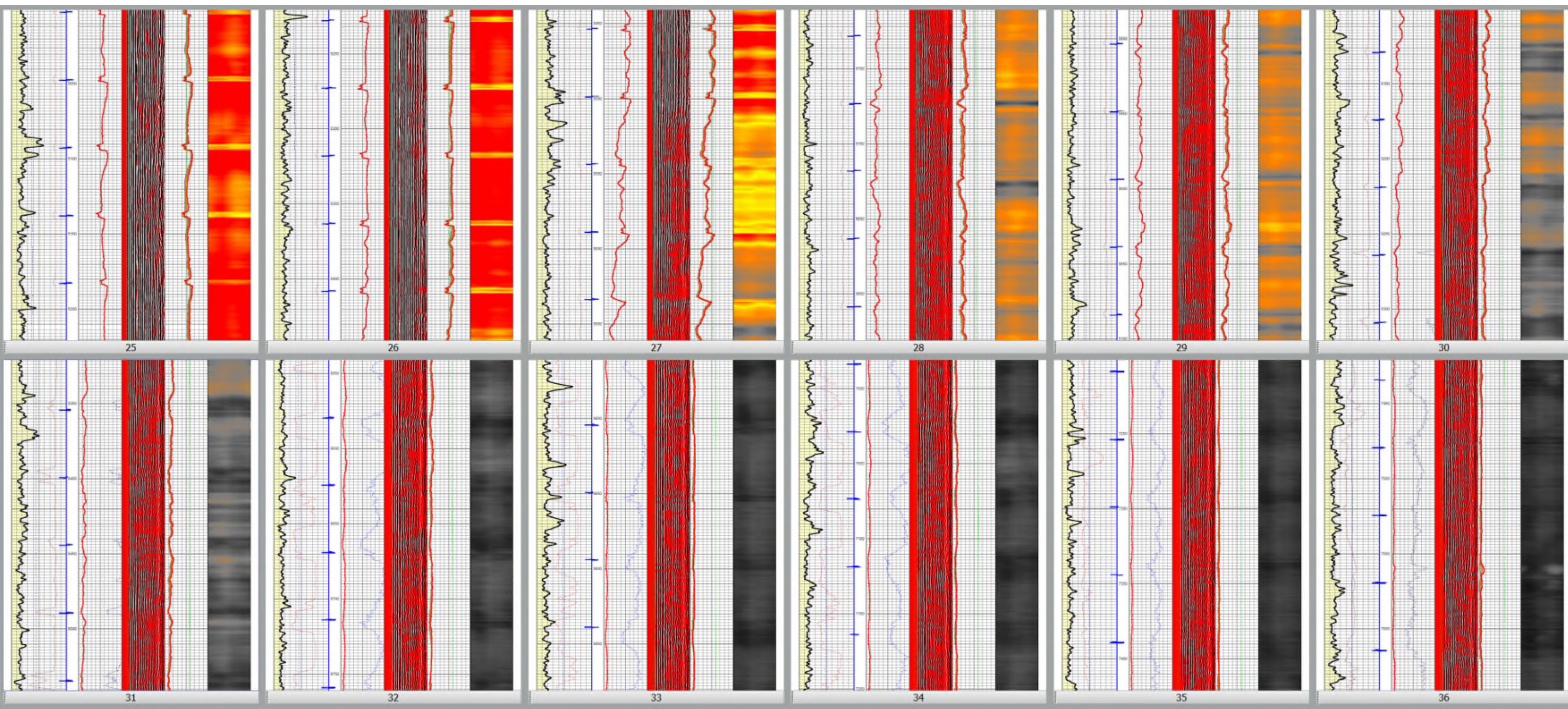

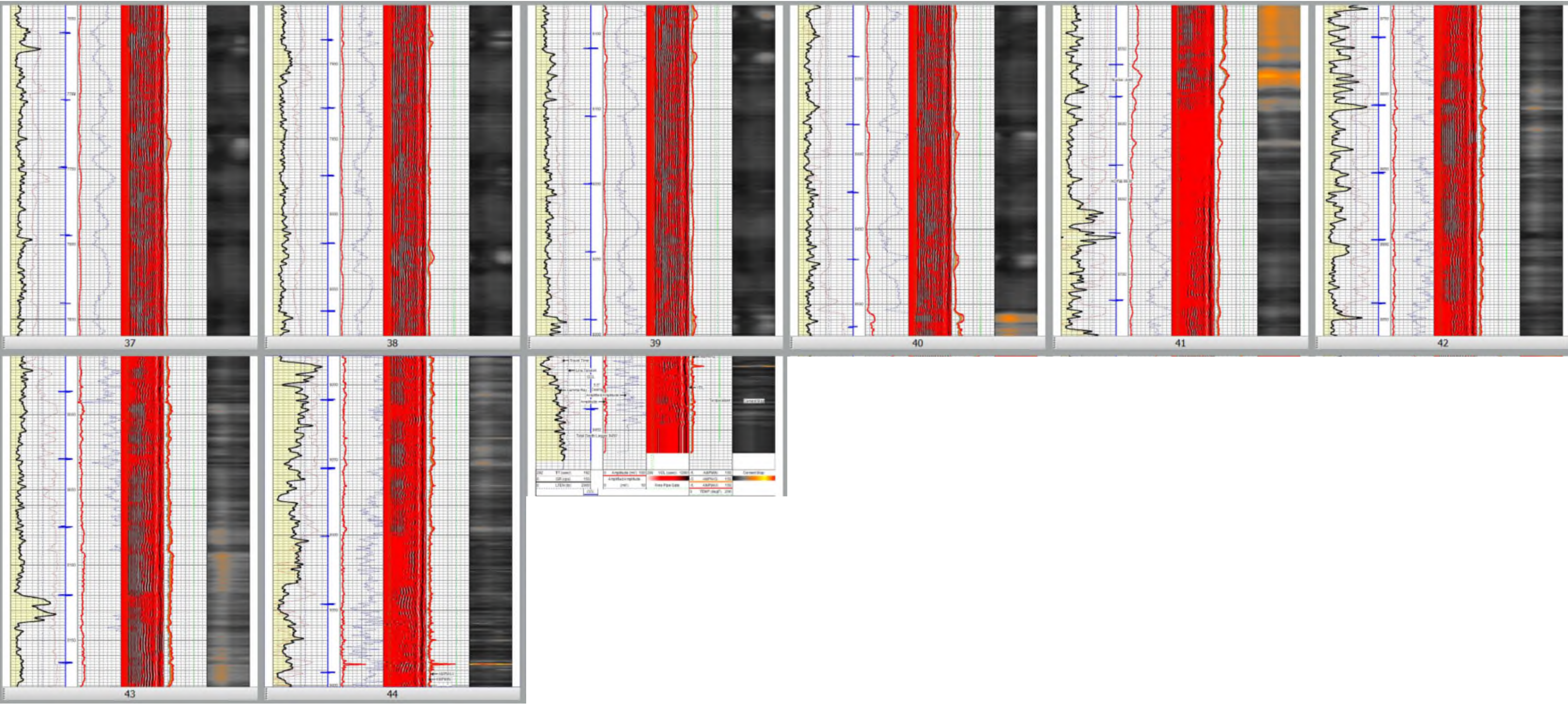

Side 1

OPERATOR: OXY USA INC

WELL NAME & NUMBER: MESA VERDE BONE SPRING UNIT 4H

WELL LOCATION: <u>280' FSL 965' FEL</u>	<u>P</u>	<u>17</u>	<u>24S</u>	<u>32E</u>
FOOTAGE LOCATION	UNIT LETTER	SECTION	TOWNSHIP	RANGE

WELLBORE SCHEMATIC

MESA VERDE BONE SPRING UNIT 4H

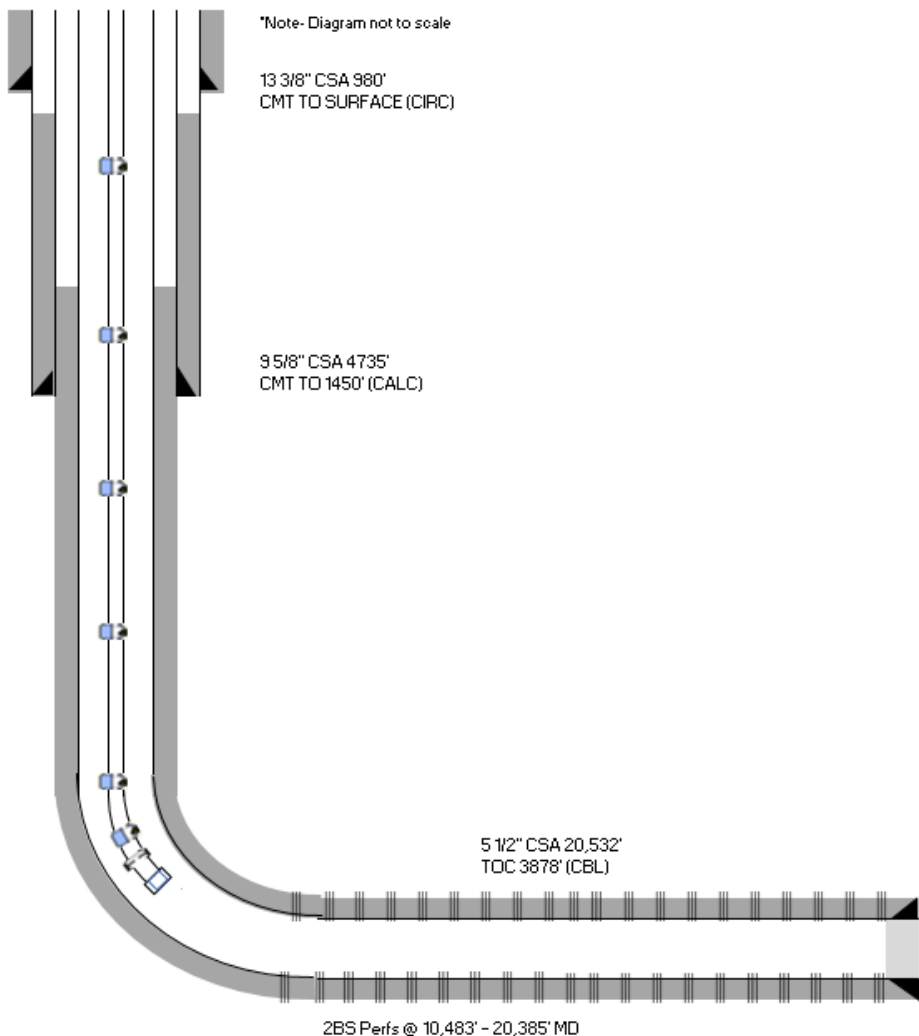

WELL CONSTRUCTION DATA

Surface Casing

Hole Size: 17.5" Casing Size: 13-3/8"
 Cemented with: 1712 sx. *or* _____ ft³
 Top of Cement: SURFACE Method Determined: CIRC

Intermediate Casing

Hole Size: 12.25" Casing Size: 9-5/8"
 Cemented with: 2060 sx. *or* _____ ft³
 Top of Cement: 1450' Method Determined: CALC

Production Casing

Hole Size: 8.5" Casing Size: 5.5"
 Cemented with: 3050 sx. *or* _____ ft³
 Top of Cement: 3878' Method Determined: CBL
 Total Depth: 20,532' MD/10,447' TVD

Injection Interval

10,483' MD/10,339' TVD feet to 20,385' MD/10,448' TVD

(Perforated or Open Hole; indicate which)

Side 2

PERF

Tubing Size: 2-3/8" Lining Material: _____

Type of Packer: _____

Packer Setting Depth: _____

Other Type of Tubing/Casing Seal (if applicable): _____

Additional Data

1. Is this a new well drilled for injection? _____ Yes X No

If no, for what purpose was the well originally drilled? _____

PRODUCER-OIL

2. Name of the Injection Formation: _____

3. Name of Field or Pool (if applicable): [96229] MESA VERDE; BONE SPRING

4. Has the well ever been perforated in any other zone(s)? List all such perforated intervals and give plugging detail, i.e. sacks of cement or plug(s) used. _____

NO

5. Give the name and depths of any oil or gas zones underlying or overlying the proposed injection zone in this area: _____

MV BS #4H CBL

RENEGADE SERVICES

Radial Cement Bond
Gamma Ray CCL
Log

Company: Occidental Petroleum, LTD
 Field: NAKA, VINA BS 4H
 County: LAKE CHARLES
 Location: LAKE CHARLES
 Log # 30101-1001

***** Thank You For Choosing Renegade Services *****
 Correlated Back To Marker Joint

RENEGADE SERVICES Main Pass (1000 PSI)

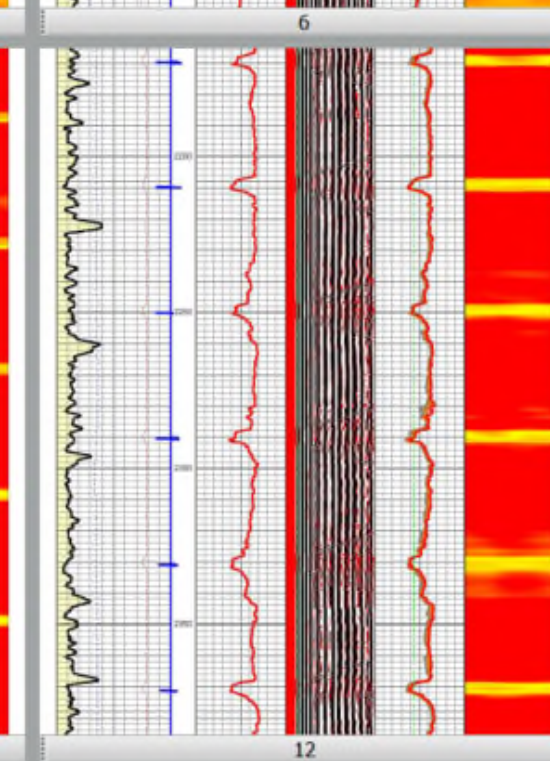
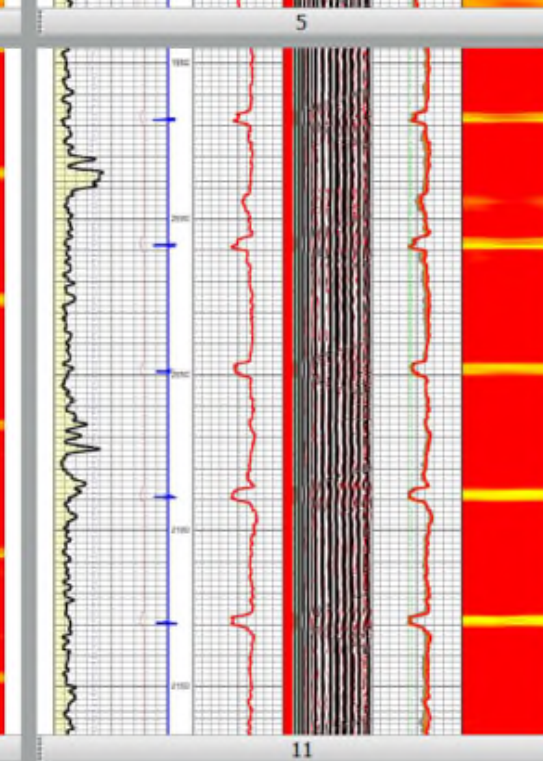
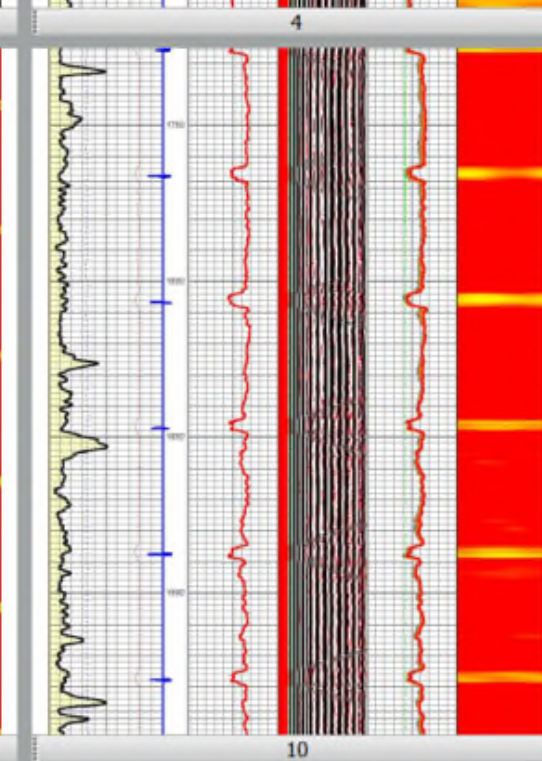
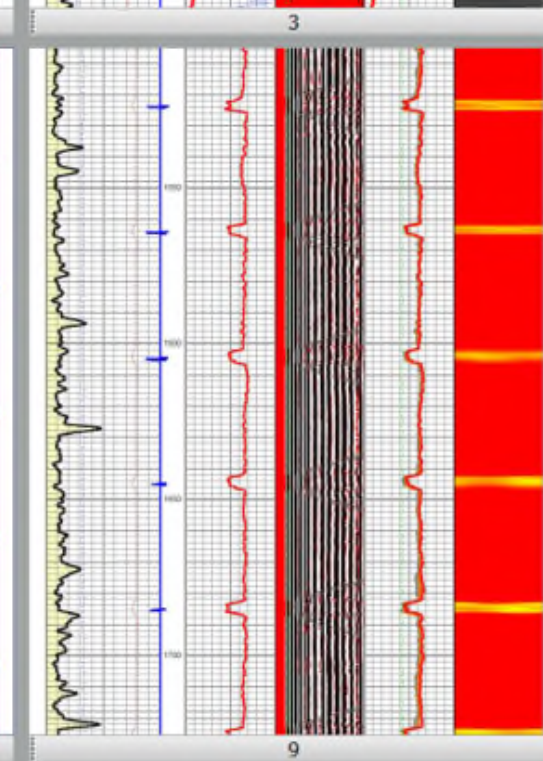
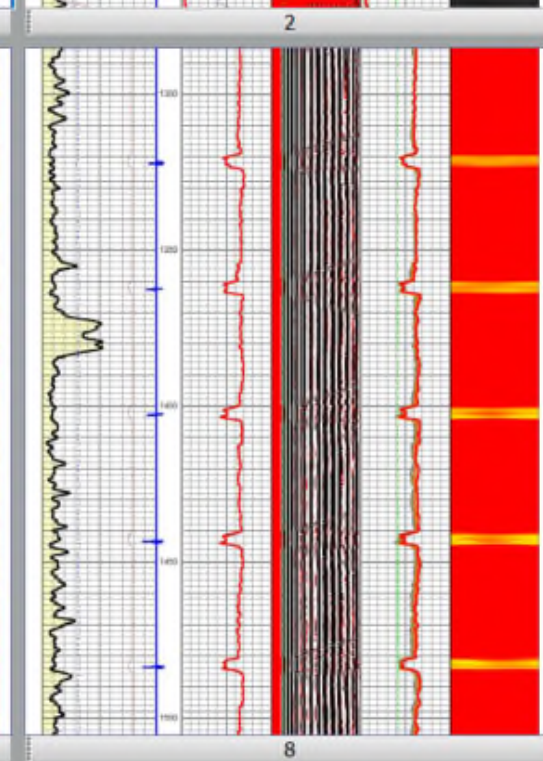
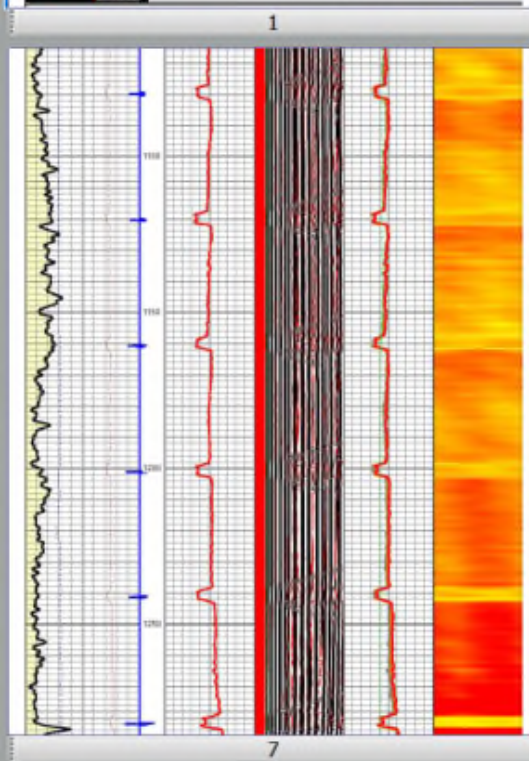
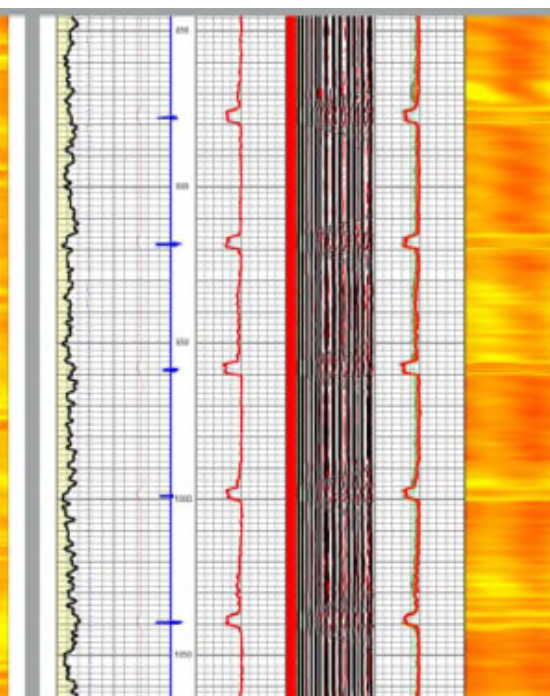
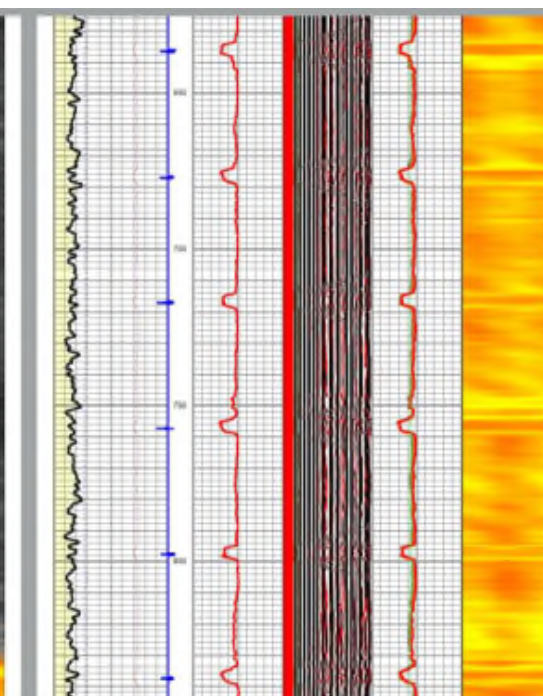
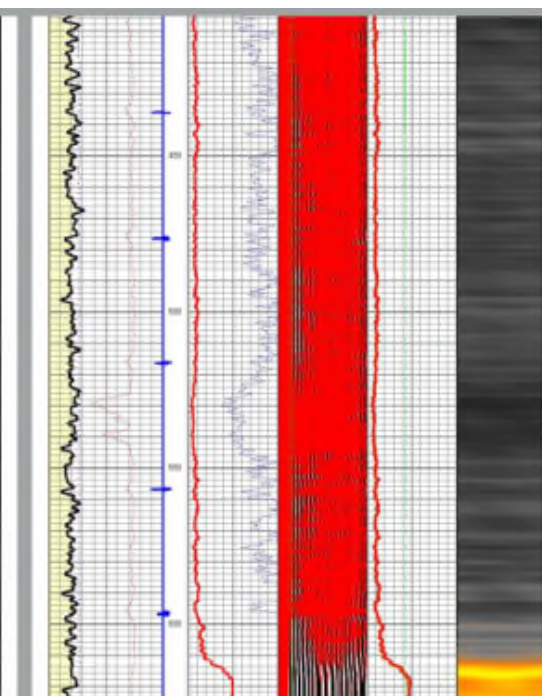
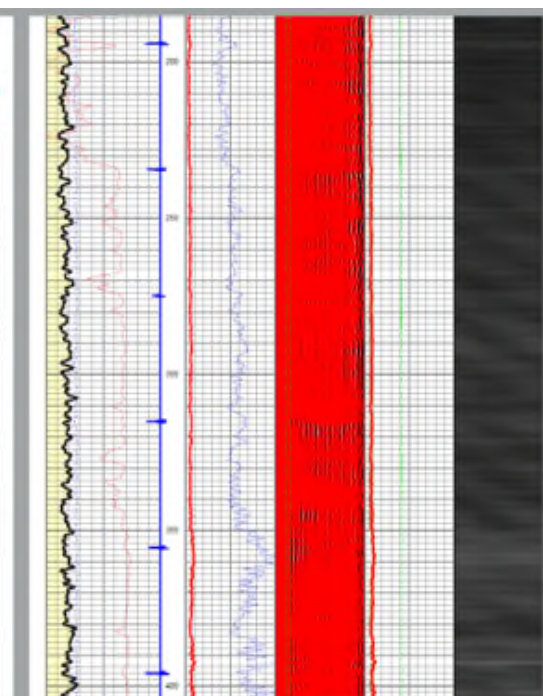
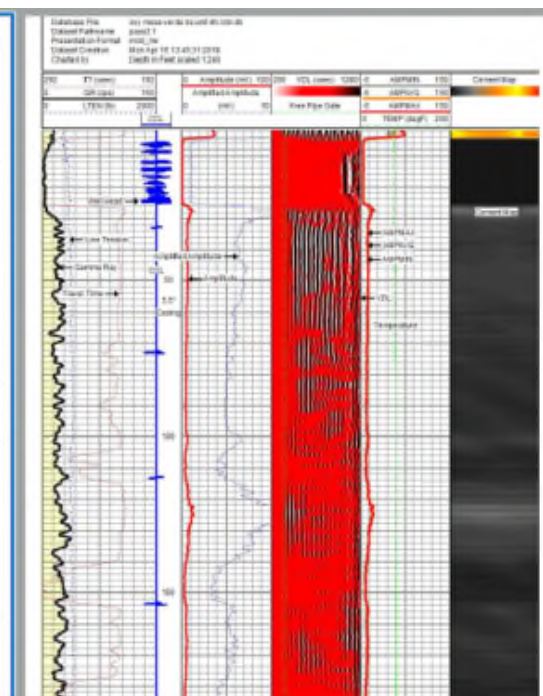

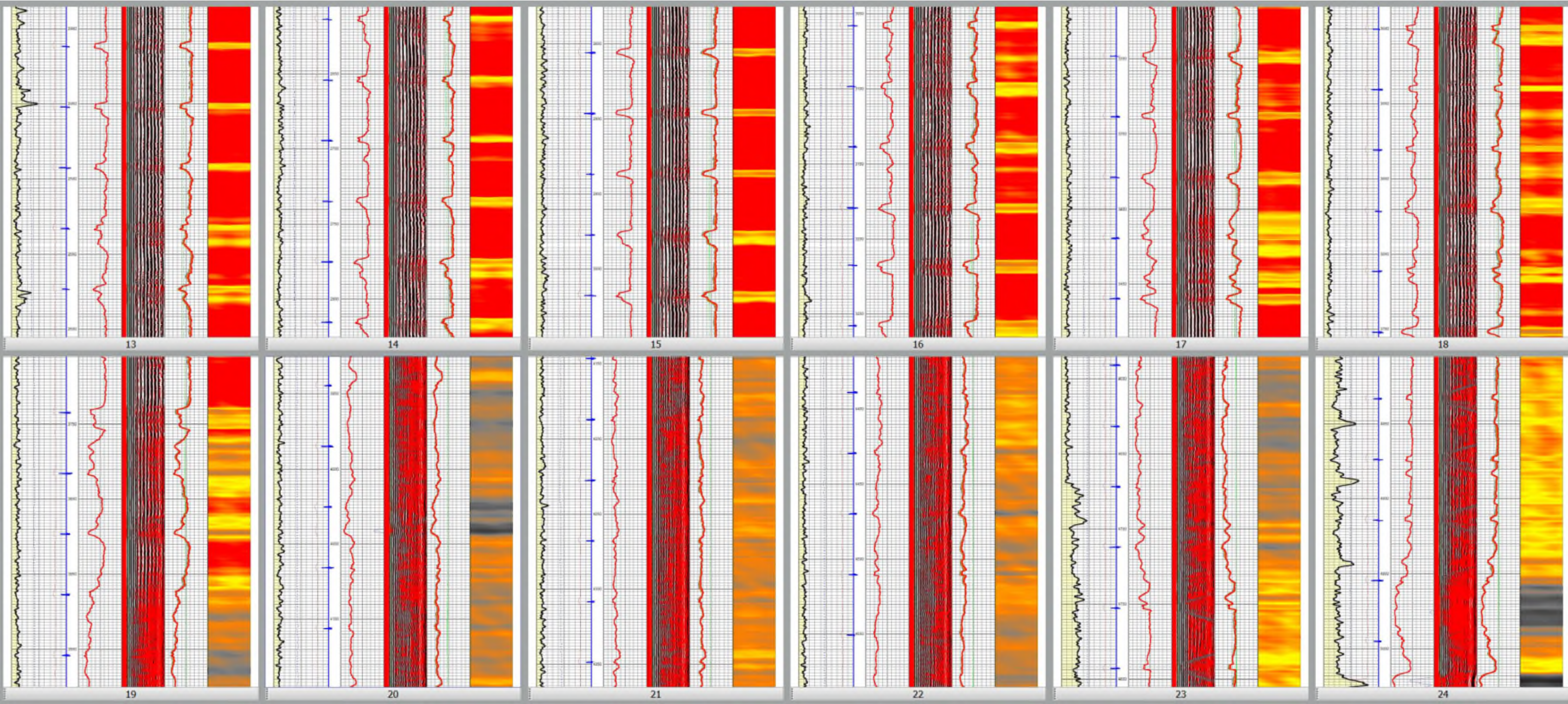

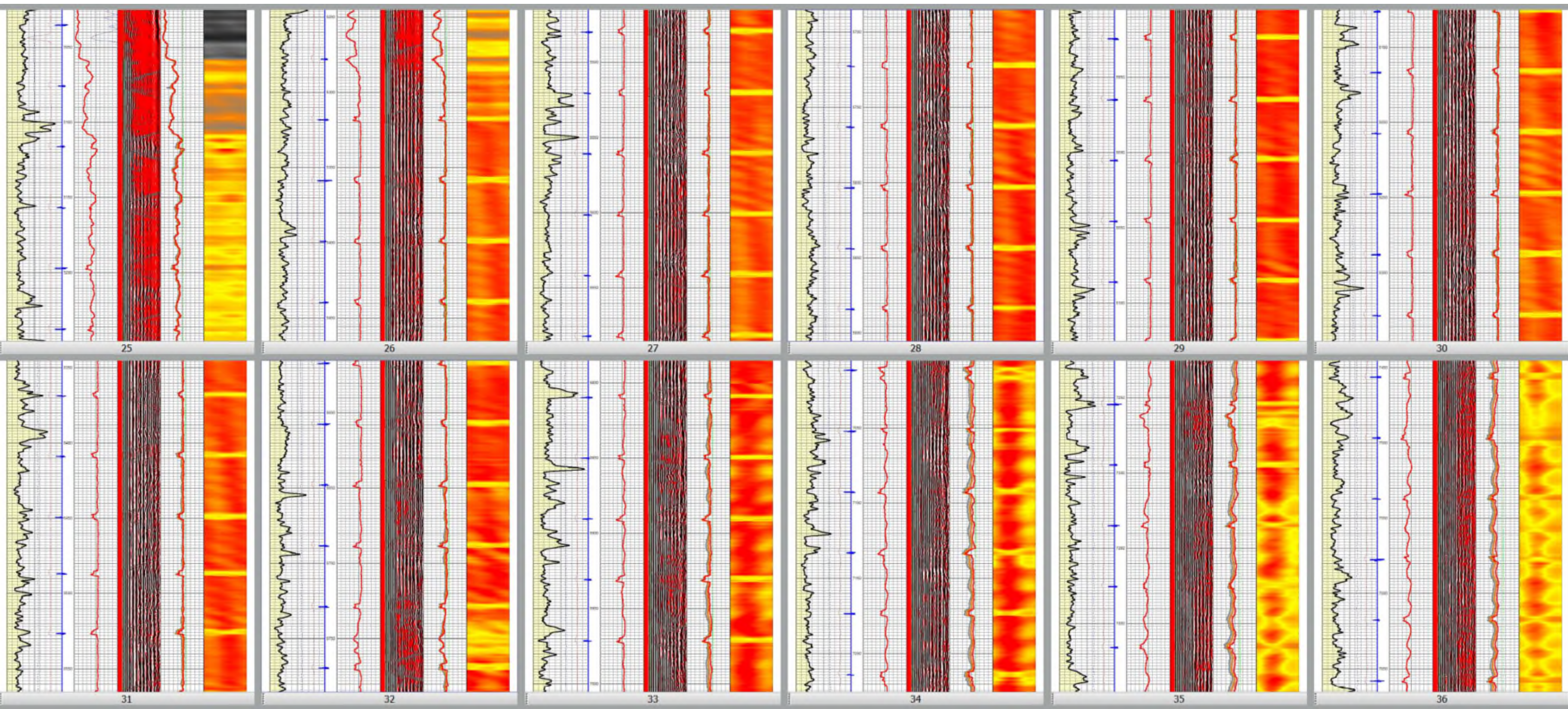

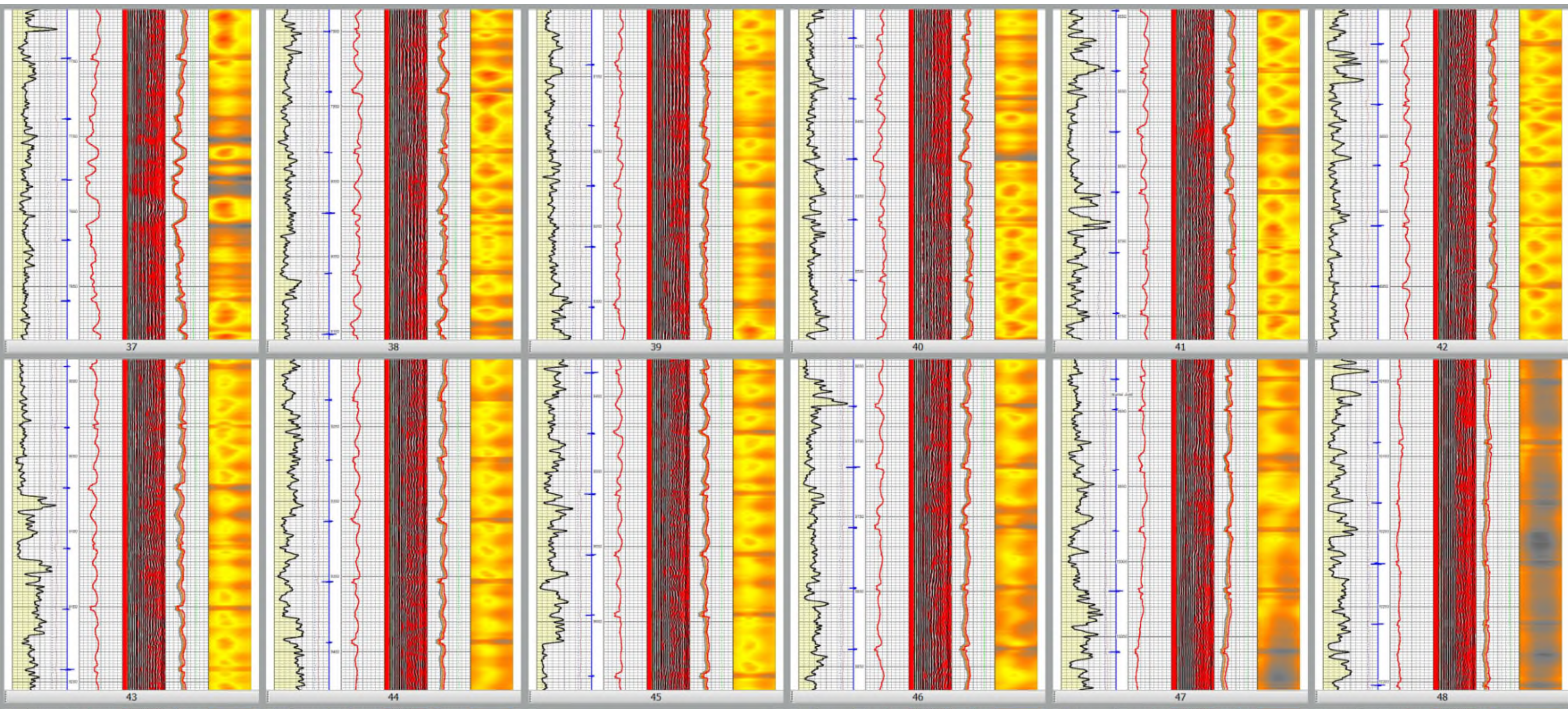

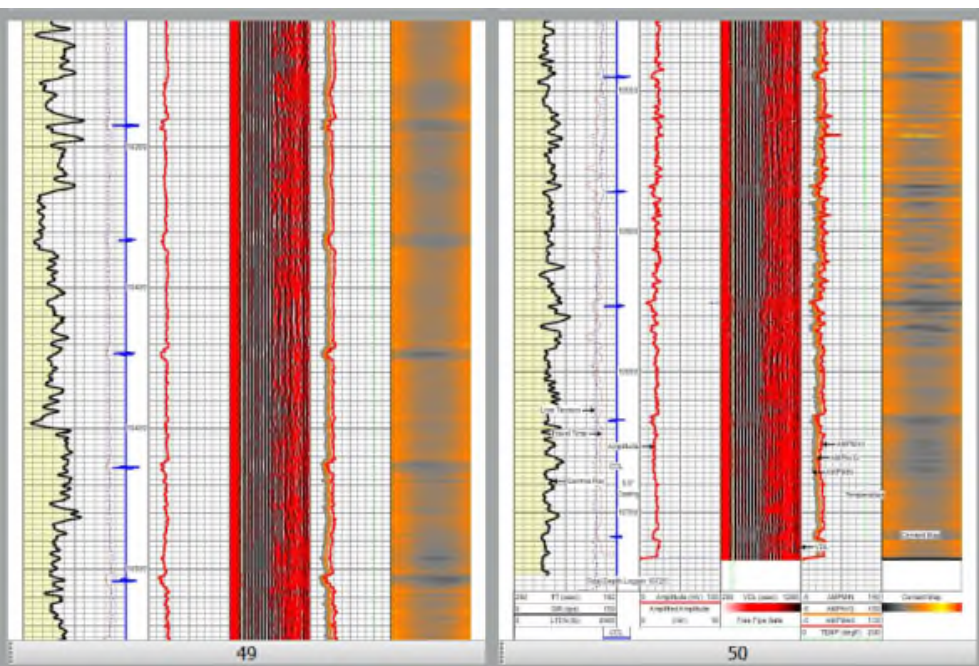

Side 1

OPERATOR: OXY USA INC

WELL NAME & NUMBER: MESA VERDE BONE SPRING UNIT 5H

WELL LOCATION: <u>280' FSL 995' FEL</u>	<u>P</u>	<u>17</u>	<u>24S</u>	<u>32E</u>
FOOTAGE LOCATION	UNIT LETTER	SECTION	TOWNSHIP	RANGE

WELLBORE SCHEMATIC

WELL CONSTRUCTION DATA
Surface Casing

MESA VERDE BONE SPRING UNIT 5H

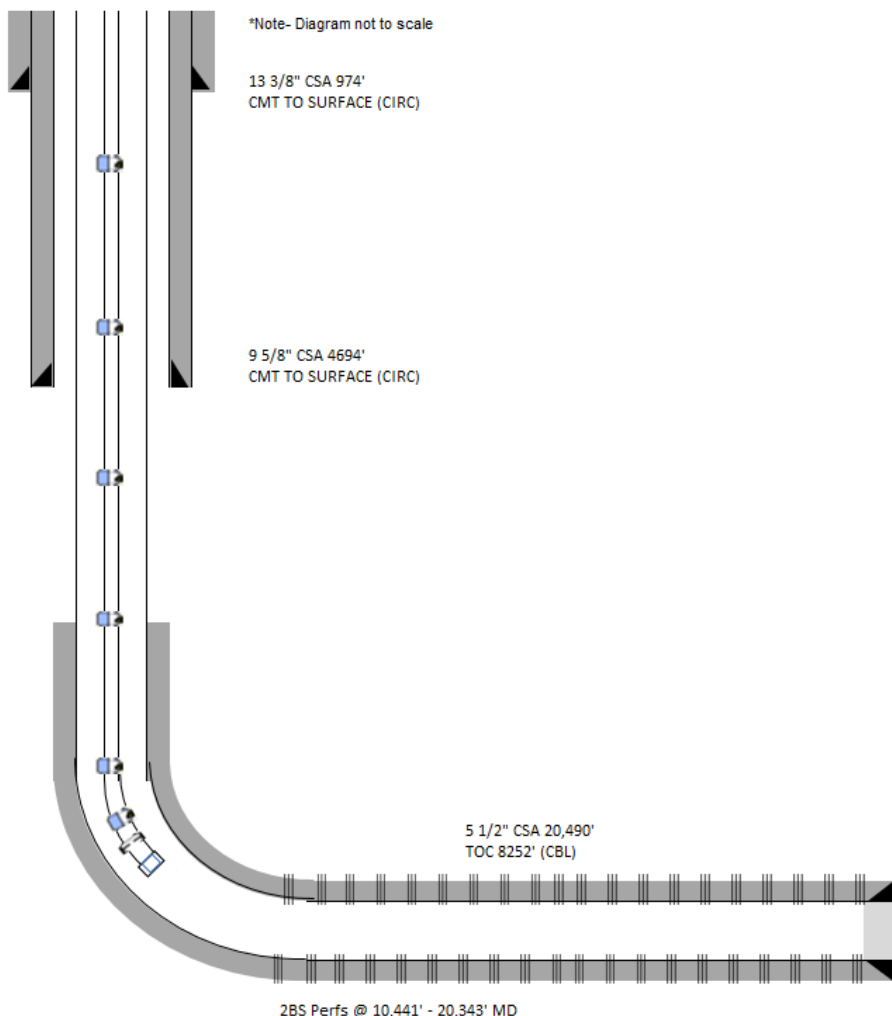

Hole Size: 17.5" Casing Size: 13-3/8"
 Cemented with: 1245 sx. *or* _____ ft³
 Top of Cement: SURFACE Method Determined: CIRC

Intermediate Casing

Hole Size: 12.25" Casing Size: 9-5/8"
 Cemented with: 1290 sx. *or* _____ ft³
 Top of Cement: SURFACE Method Determined: CIRC

Production Casing

Hole Size: 8.5" Casing Size: 5.5"
 Cemented with: 2895 sx. *or* _____ ft³
 Top of Cement: 8252' Method Determined: CBL

Total Depth: 20,290' MD/10,449' TVD

Injection Interval

10,441' MD/10,339' TVD feet to 20,343' MD/10,449' TVD

(Perforated or Open Hole; indicate which)

Side 2

PERF

Tubing Size: 2-3/8" Lining Material: _____

Type of Packer: _____

Packer Setting Depth: _____

Other Type of Tubing/Casing Seal (if applicable): _____

Additional Data

1. Is this a new well drilled for injection? _____ Yes X No

If no, for what purpose was the well originally drilled? _____

PRODUCER-OIL

2. Name of the Injection Formation: _____

3. Name of Field or Pool (if applicable): [96229] MESA VERDE; BONE SPRING

4. Has the well ever been perforated in any other zone(s)? List all such perforated intervals and give plugging detail, i.e. sacks of cement or plug(s) used. _____

NO

5. Give the name and depths of any oil or gas zones underlying or overlying the proposed injection zone in this area: _____

MV BS #5H CBL

RENEGADE SERVICES

Company: Outsource Services, LTD
 Well: Main Pass 1000 PSI
 Well ID: 2019-001
 Location: Main Pass 1000 PSI
 Date: 07/06/2021
 Time: 11:23:48
 User: [Name]
 Job No: [Number]

Company: Outsource Services, LTD
 Well: Main Pass 1000 PSI
 Well ID: 2019-001
 Location: Main Pass 1000 PSI
 Date: 07/06/2021
 Time: 11:23:48
 User: [Name]
 Job No: [Number]

***** Thank You For Choosing Renegade Services *****
 Correlated Back To Marker Joint

RENEGADE SERVICES Main Pass (1000 PSI)

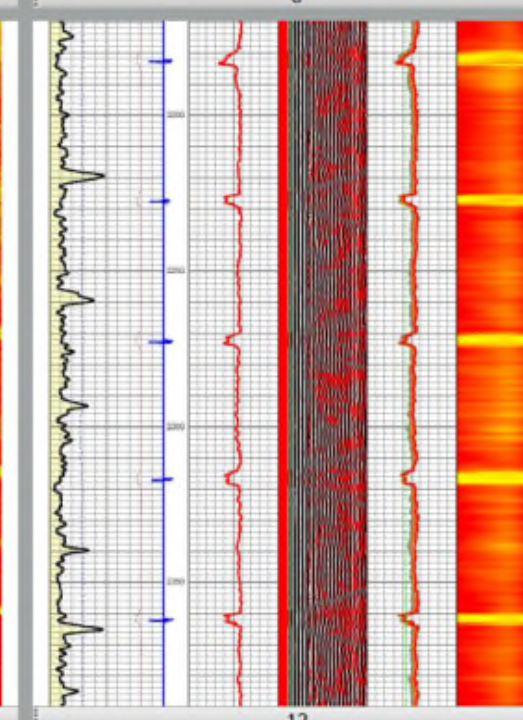
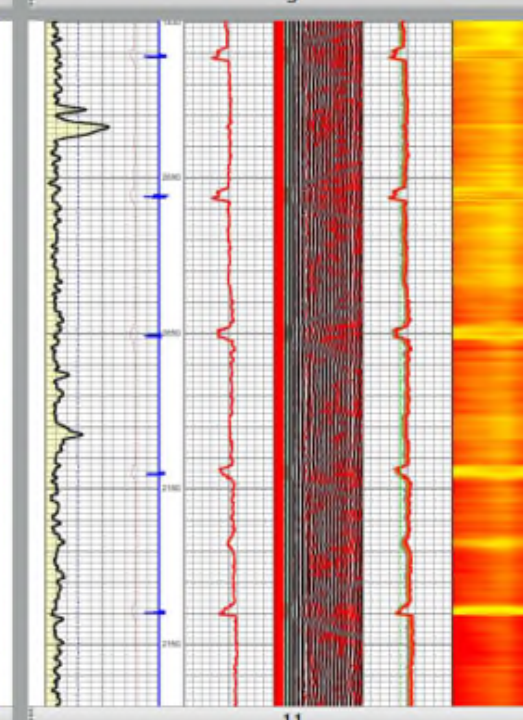
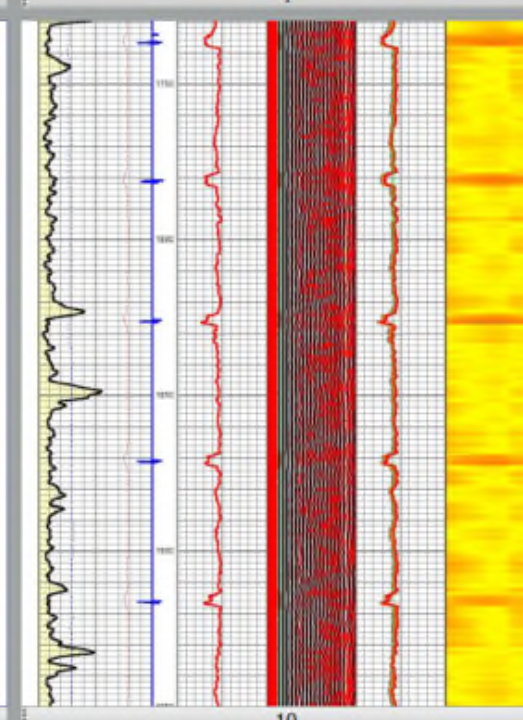
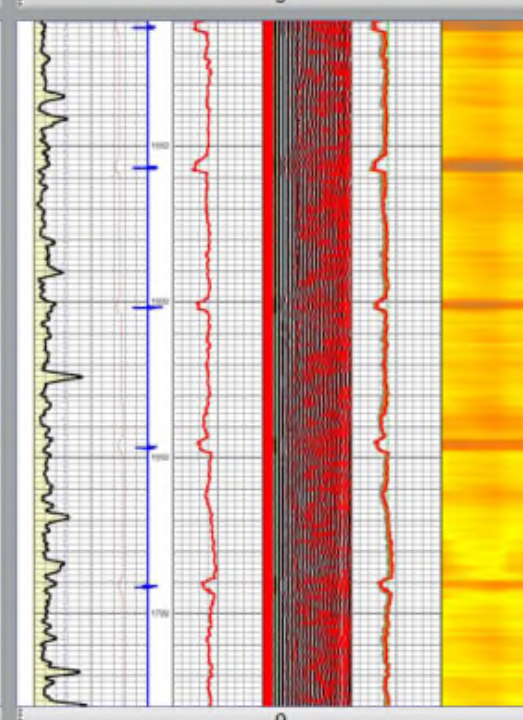
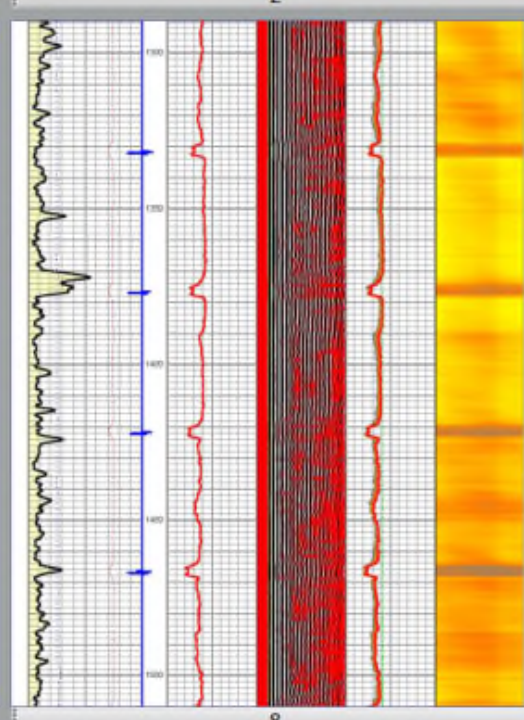
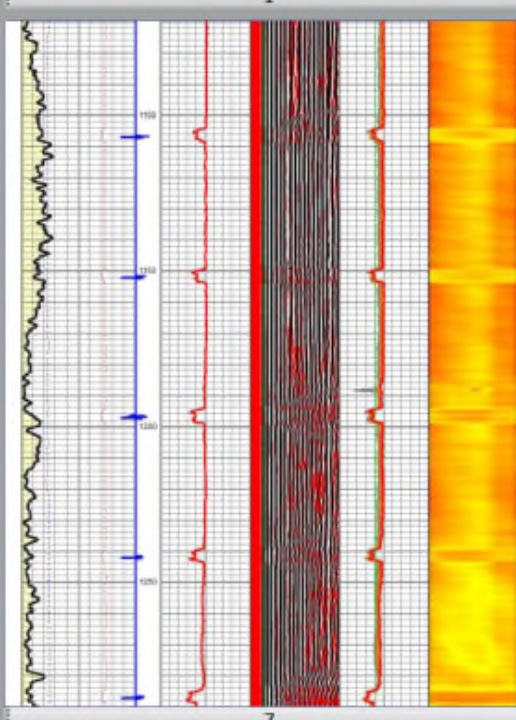
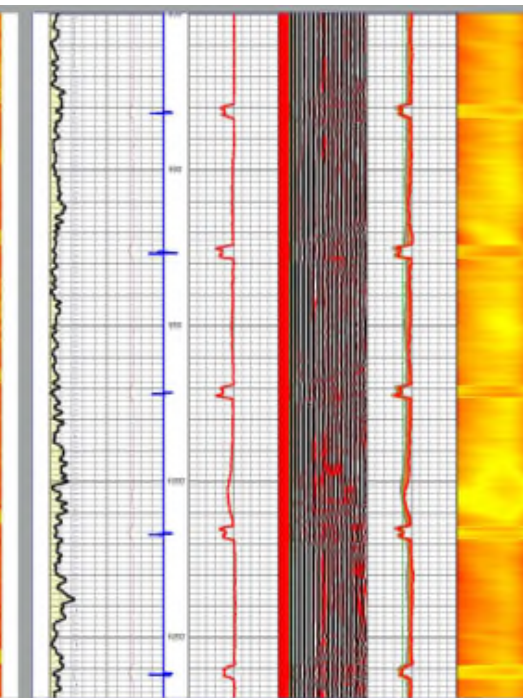
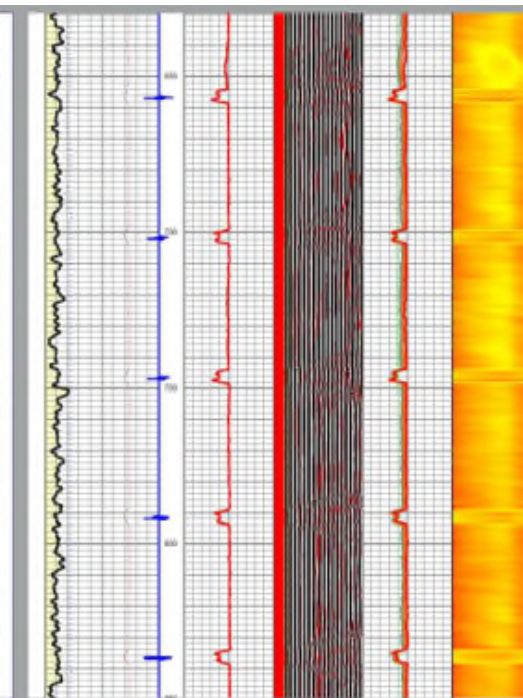
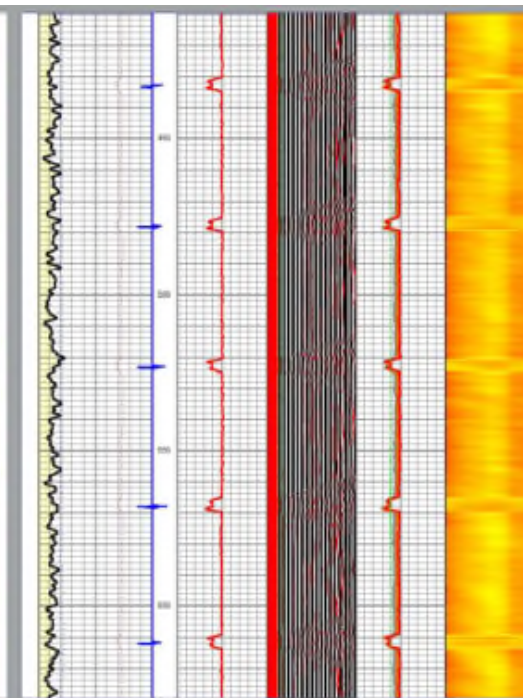
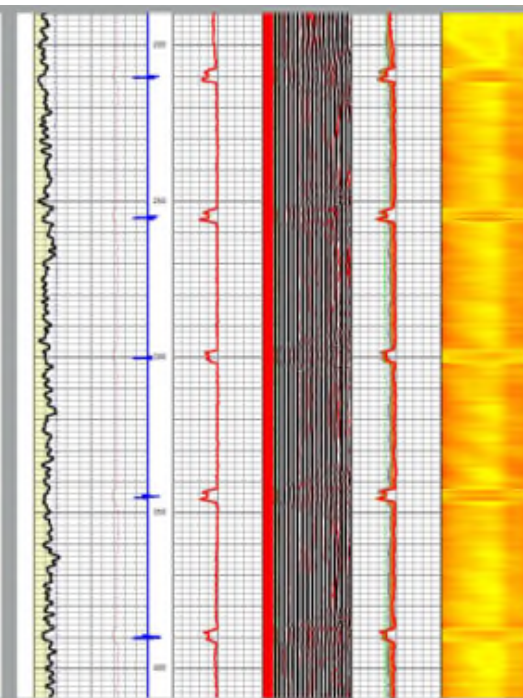
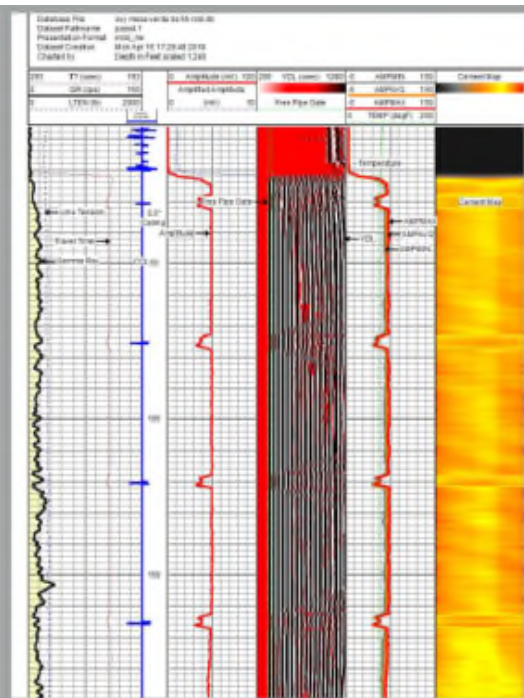

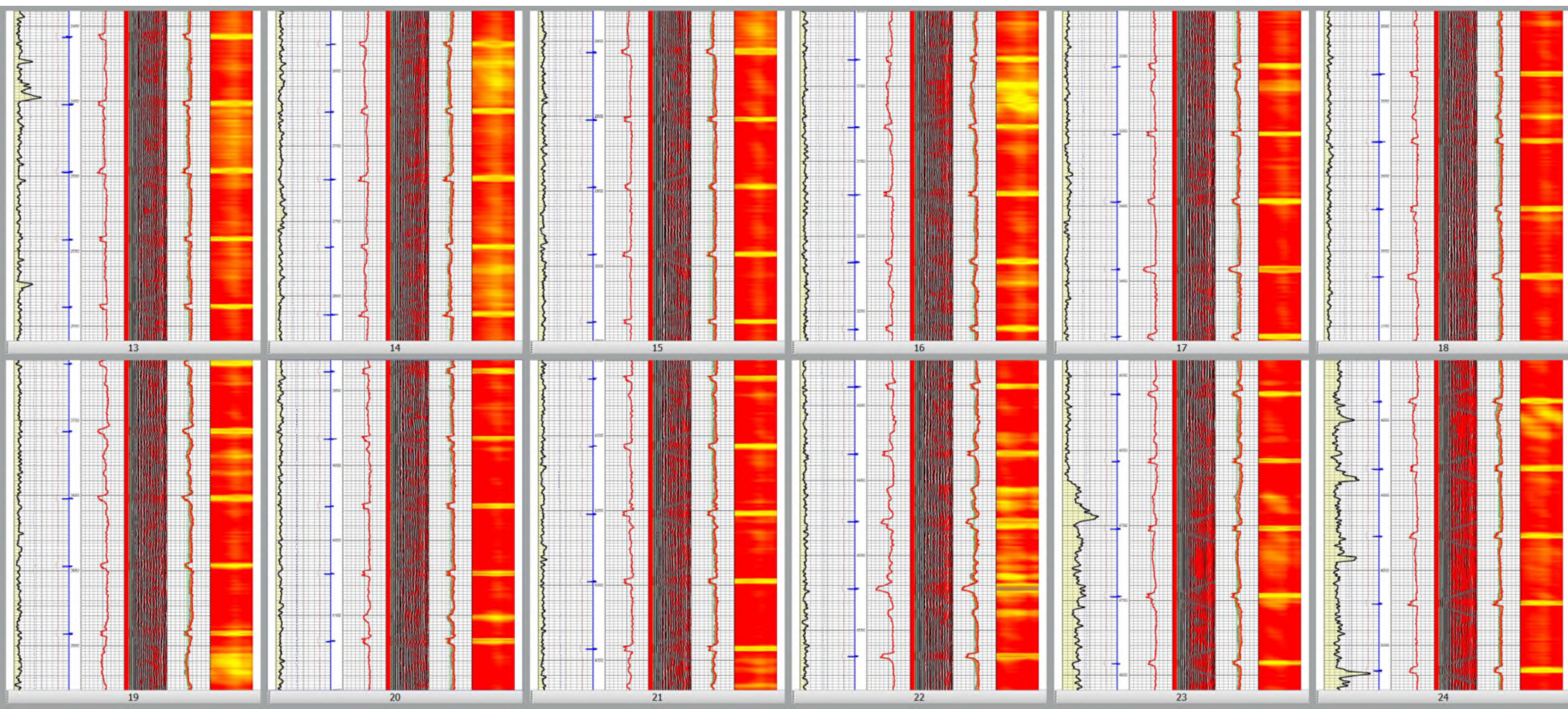

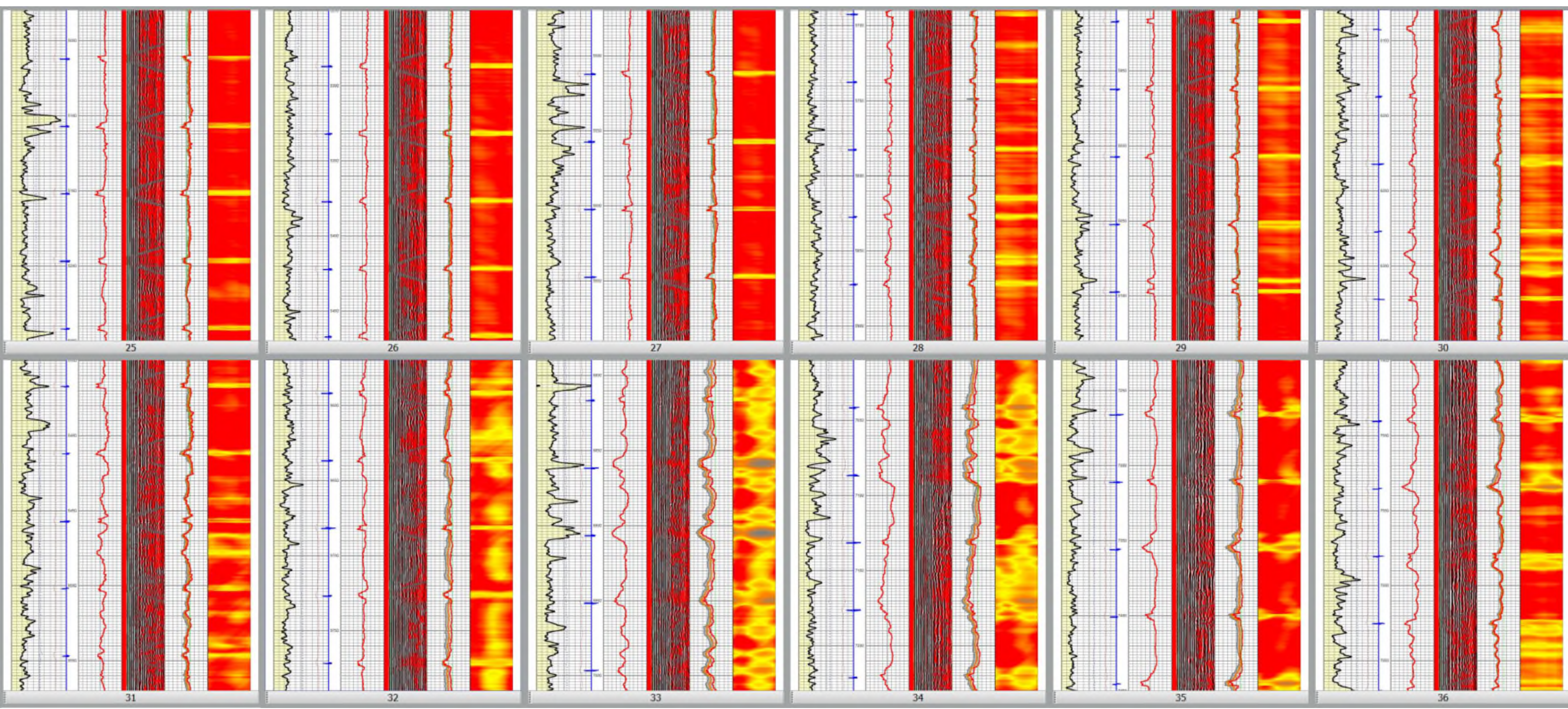

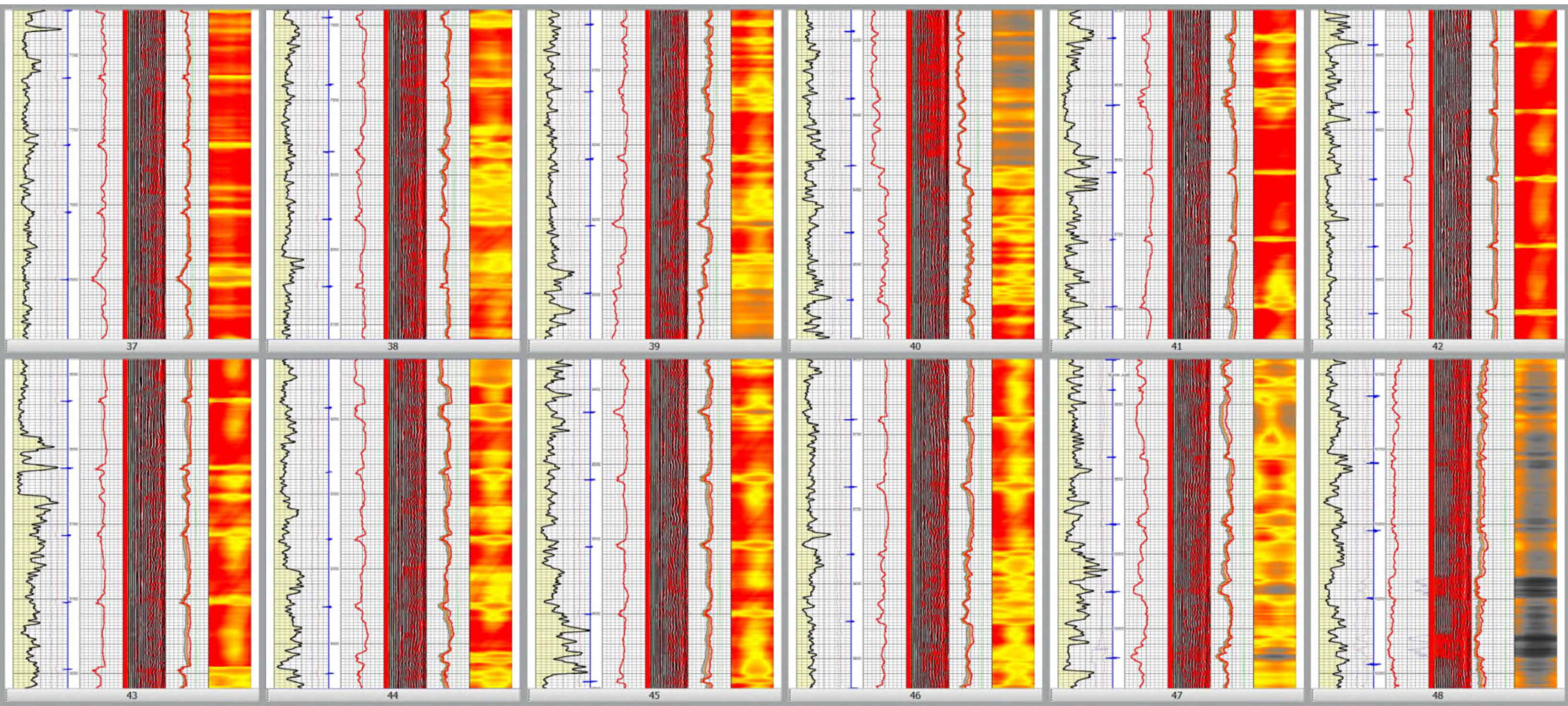

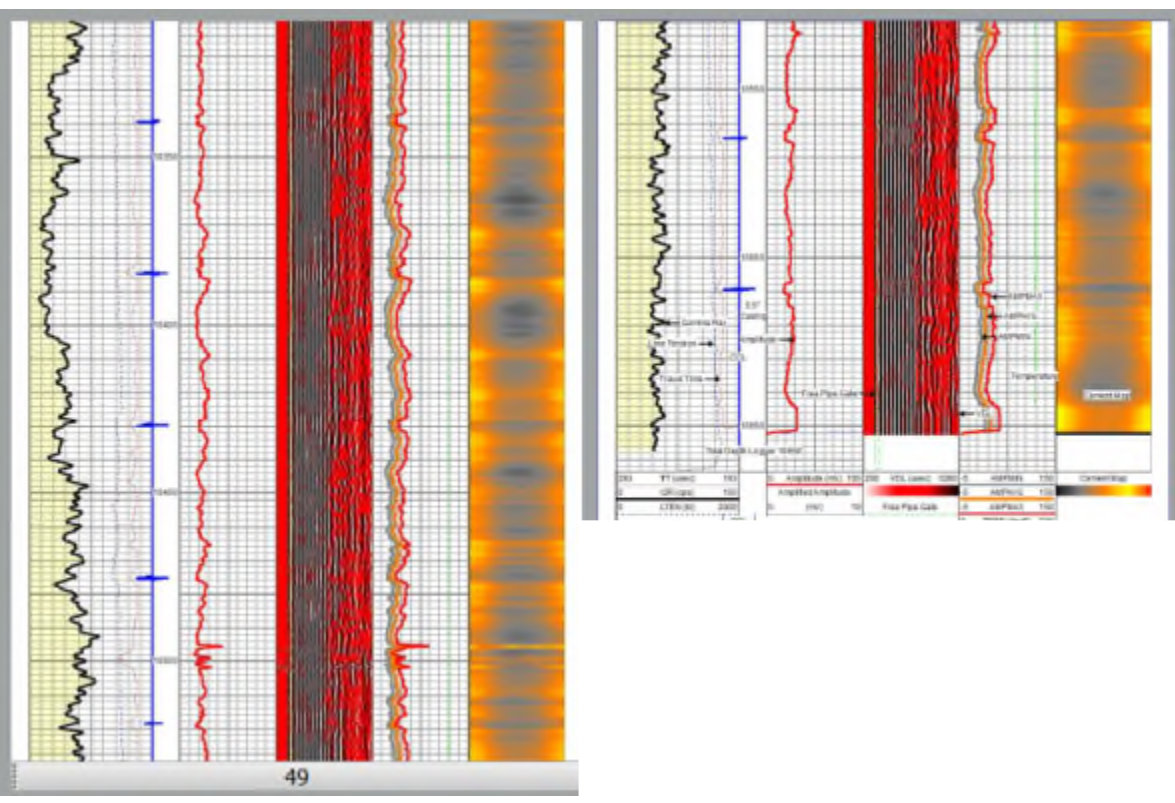

Side 2

PERF

Tubing Size: 2-3/8" SET AT 11037' MD/10405' TVD Lining Material: UNLINED

Type of Packer: NA

Packer Setting Depth: NA- FOR MIT, SET PACKER NO GREATER THAN 100' ABOVE TVD OF THE KOP

Other Type of Tubing/Casing Seal (if applicable): _____

Additional Data

1. Is this a new well drilled for injection? _____ Yes X No

If no, for what purpose was the well originally drilled? _____
PRODUCER-OIL

2. Name of the Injection Formation: _____

3. Name of Field or Pool (if applicable): [96229] MESA VERDE; BONE SPRING

4. Has the well ever been perforated in any other zone(s)? List all such perforated intervals and give plugging detail, i.e. sacks of cement or plug(s) used. _____
NO

5. Give the name and depths of any oil or gas zones underlying or overlying the proposed injection zone in this area: _____

MV BS #6H CBL

RENEGADE
Radial Cement Bond
Gamma Ray/CCL
Log

Company: CUYA U.S.A.
Field: Santa Victoria BS Line # 6H
County: Santa Victoria
State: New Mexico
Country: U.S.A.

Log # 302514042

1000 PSI

This Log was measured using a 26.5" R.B. @ Ground Level
All Depths Are Logger Depths

RENEGADE
Main Pass (1000 psi)

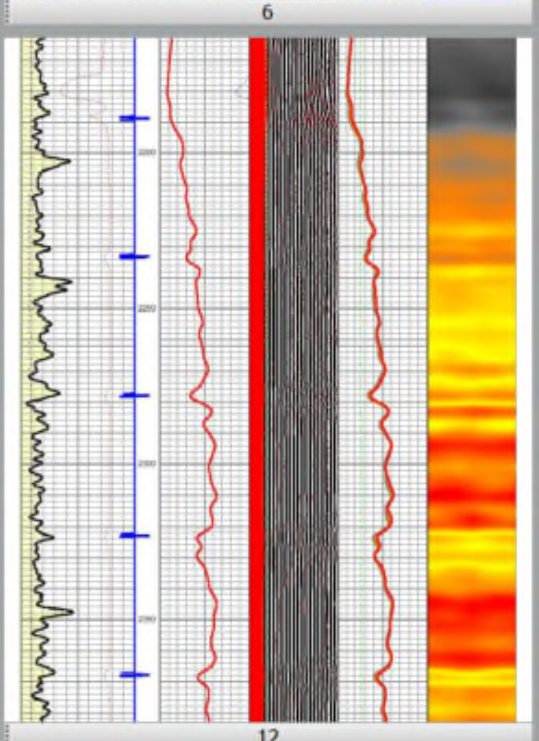
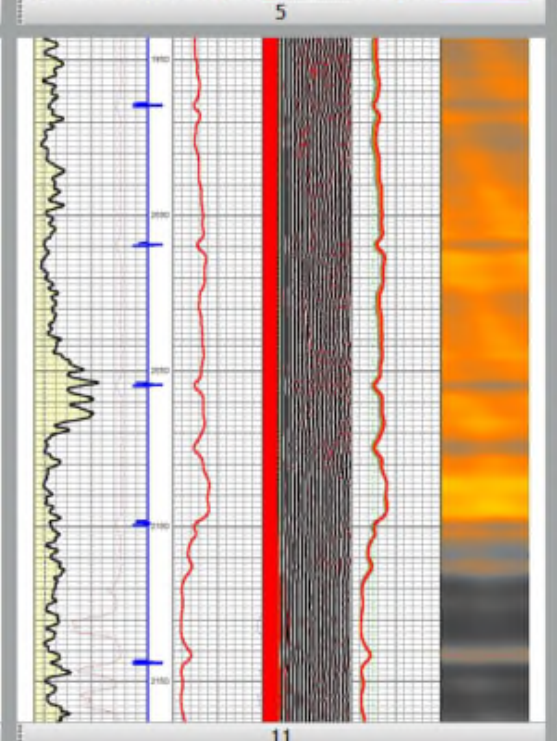
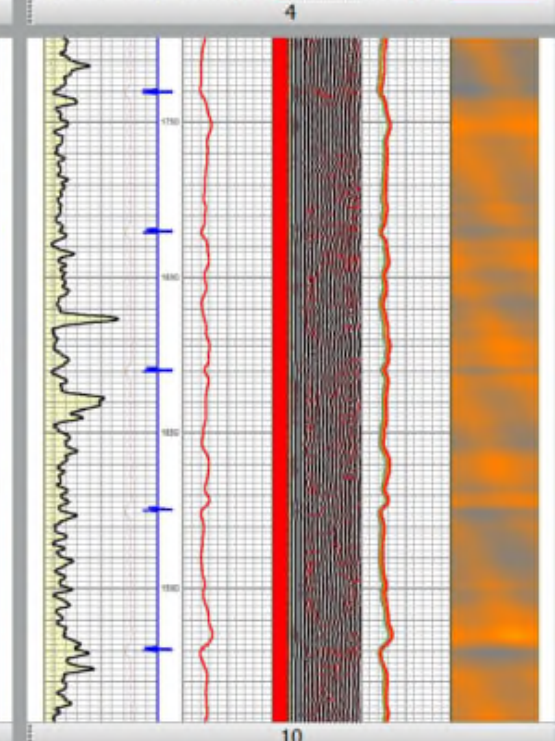
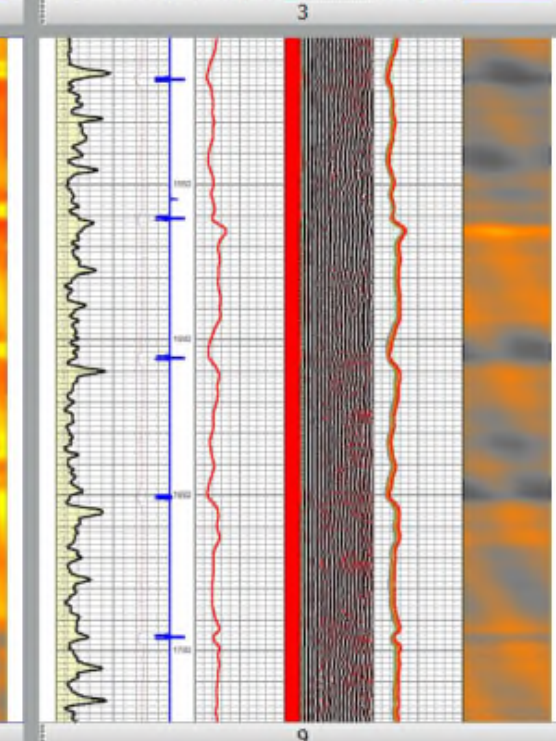
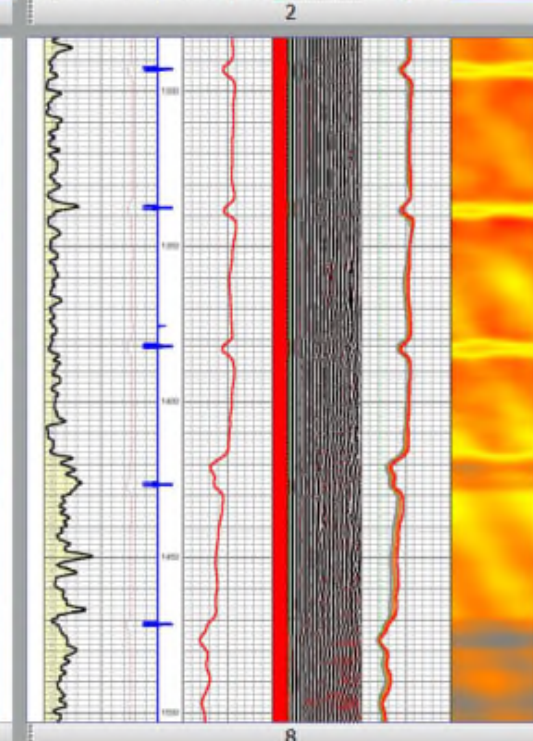
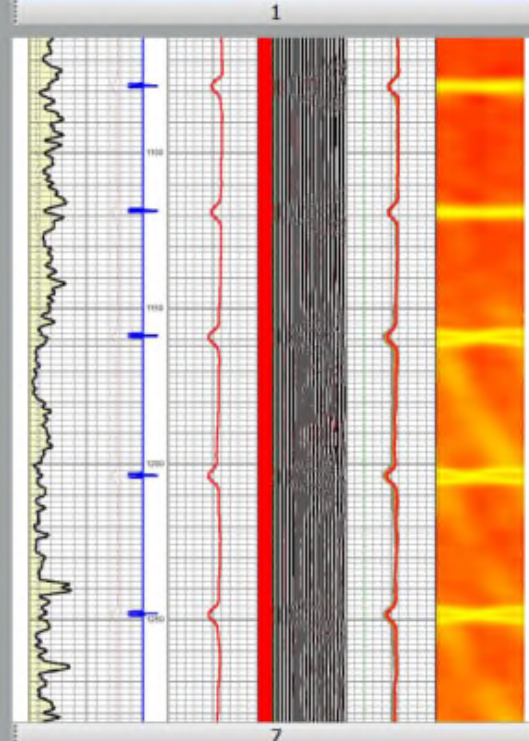
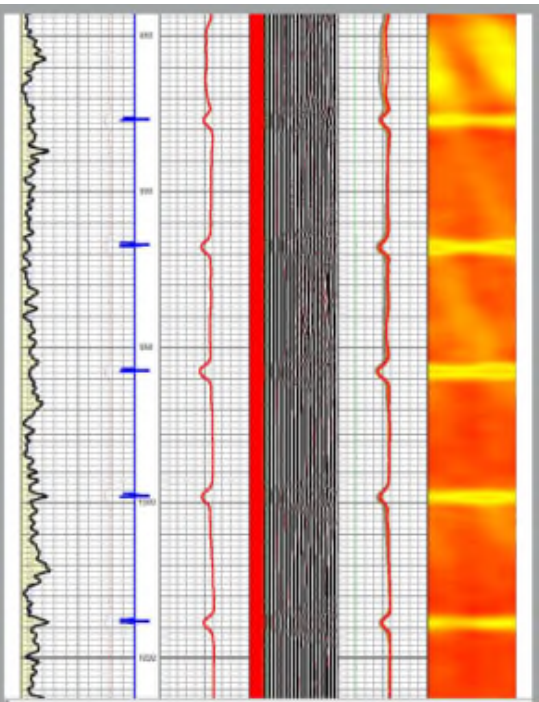
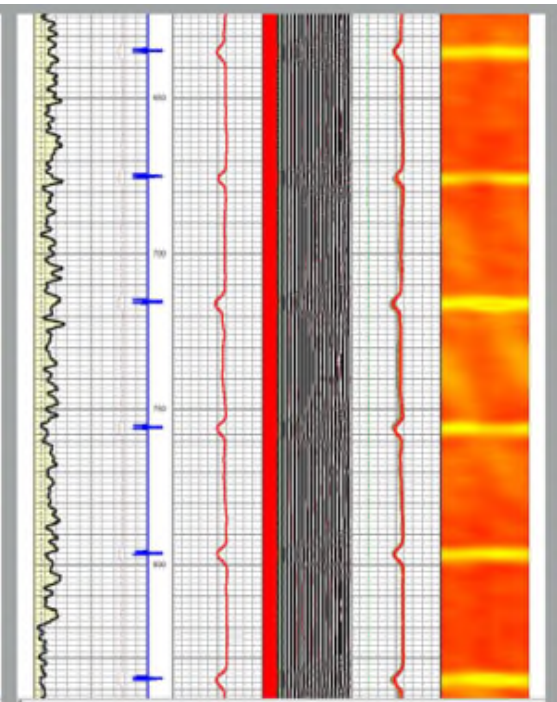
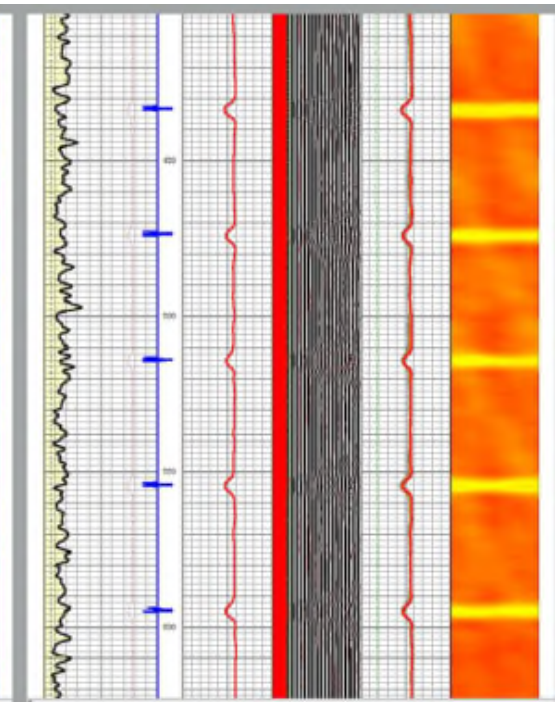
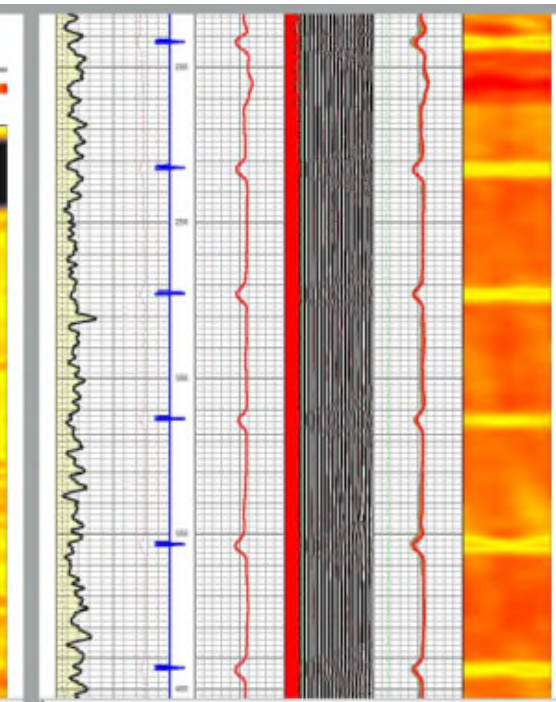
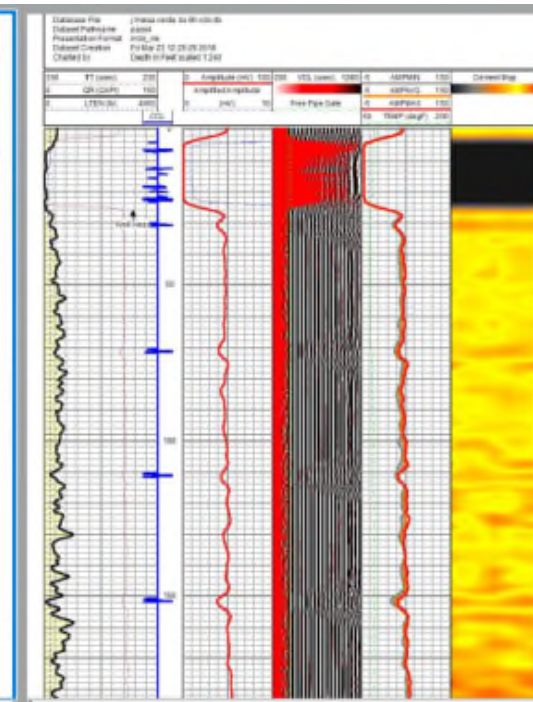

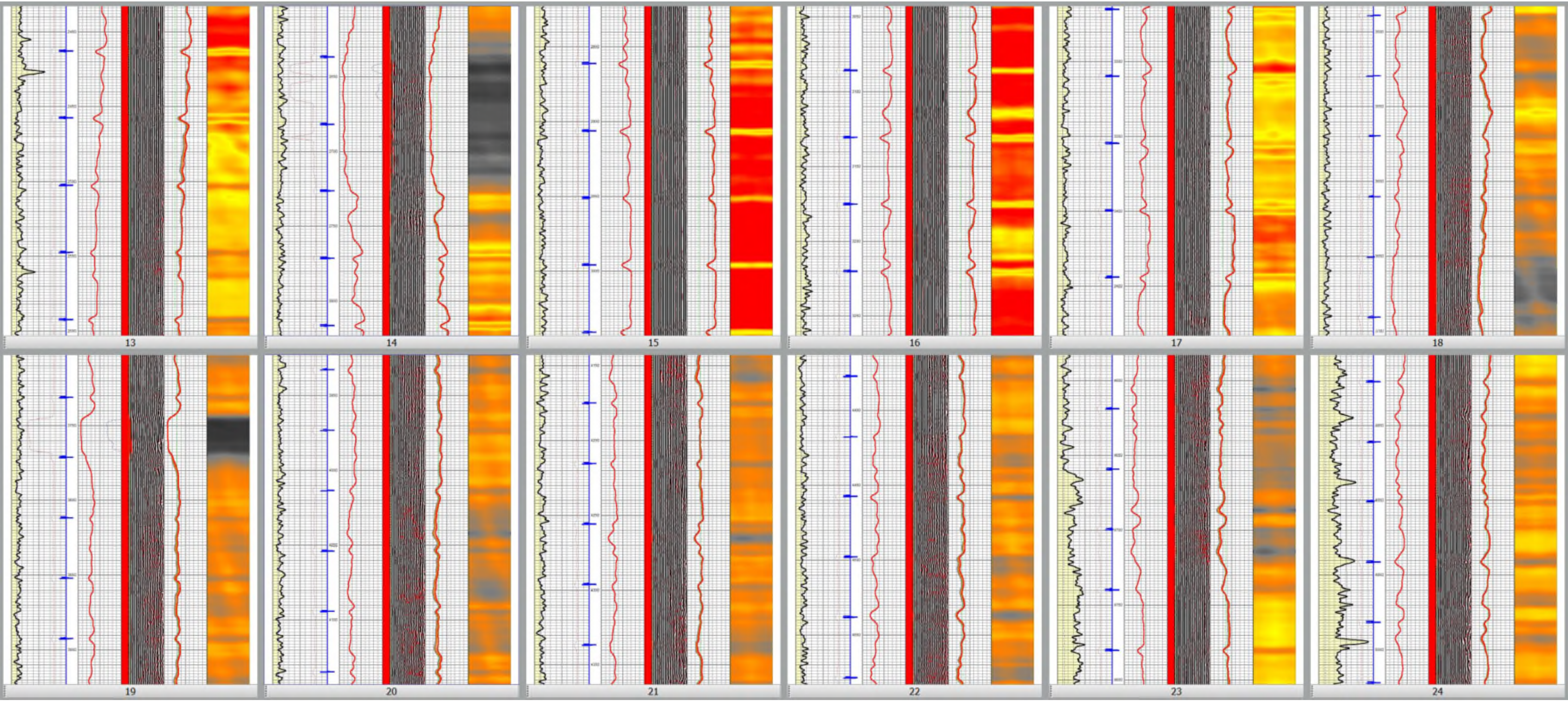

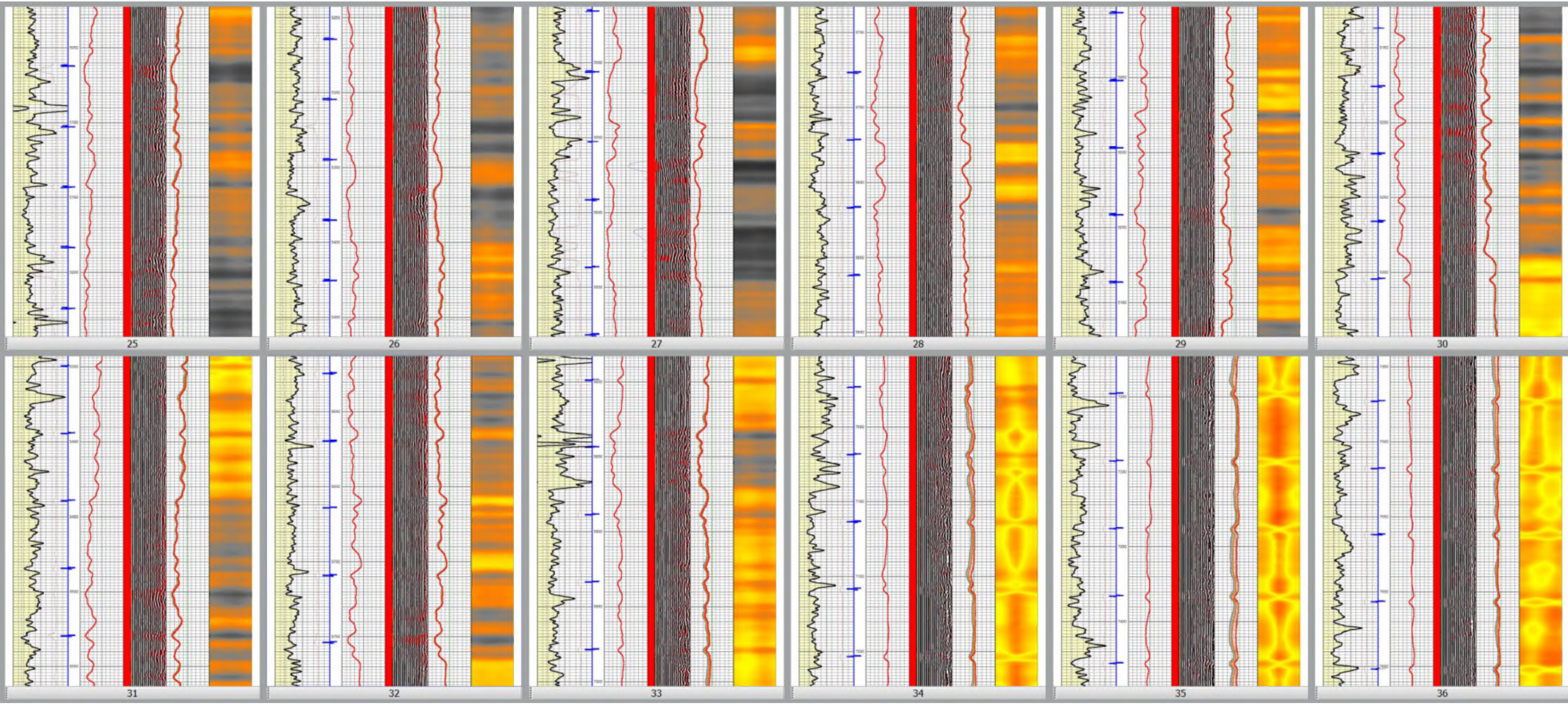

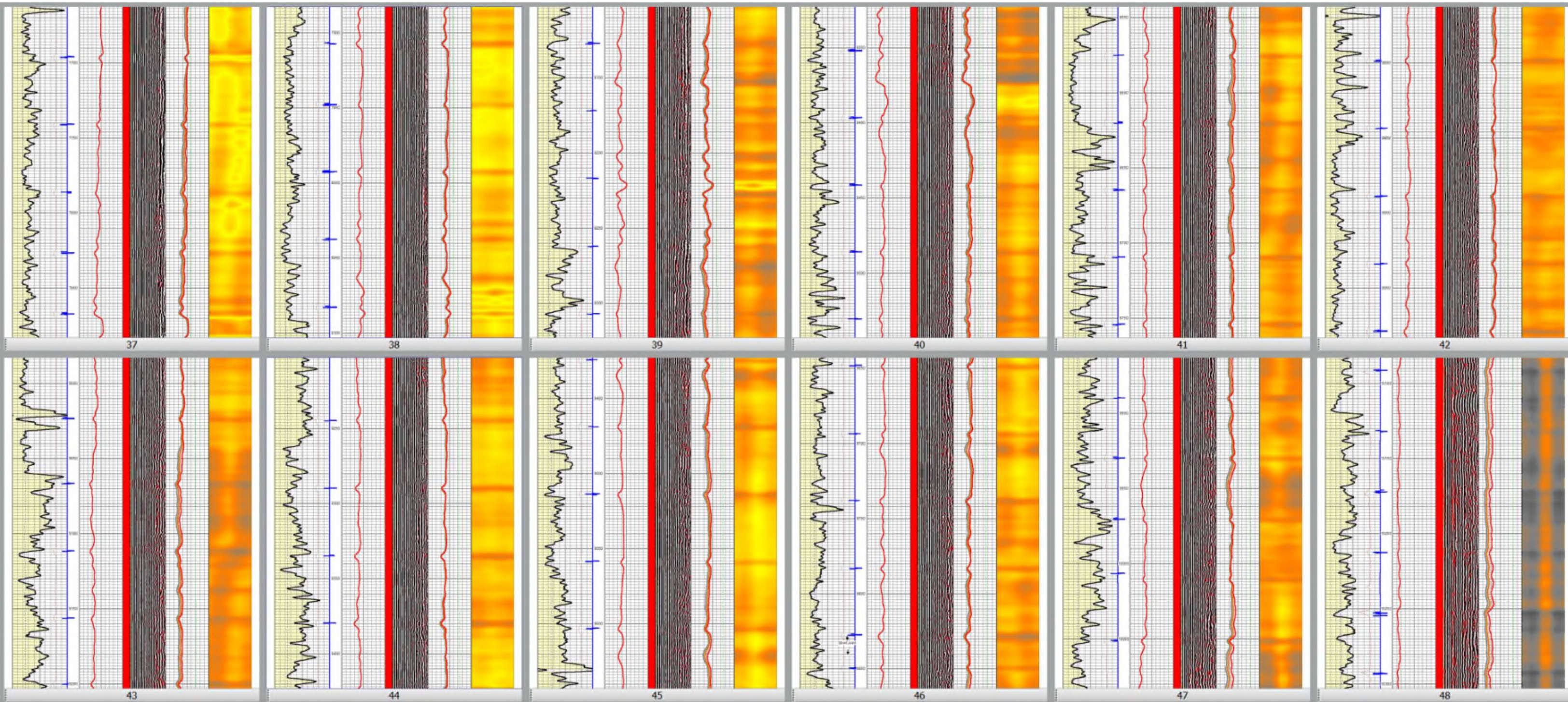

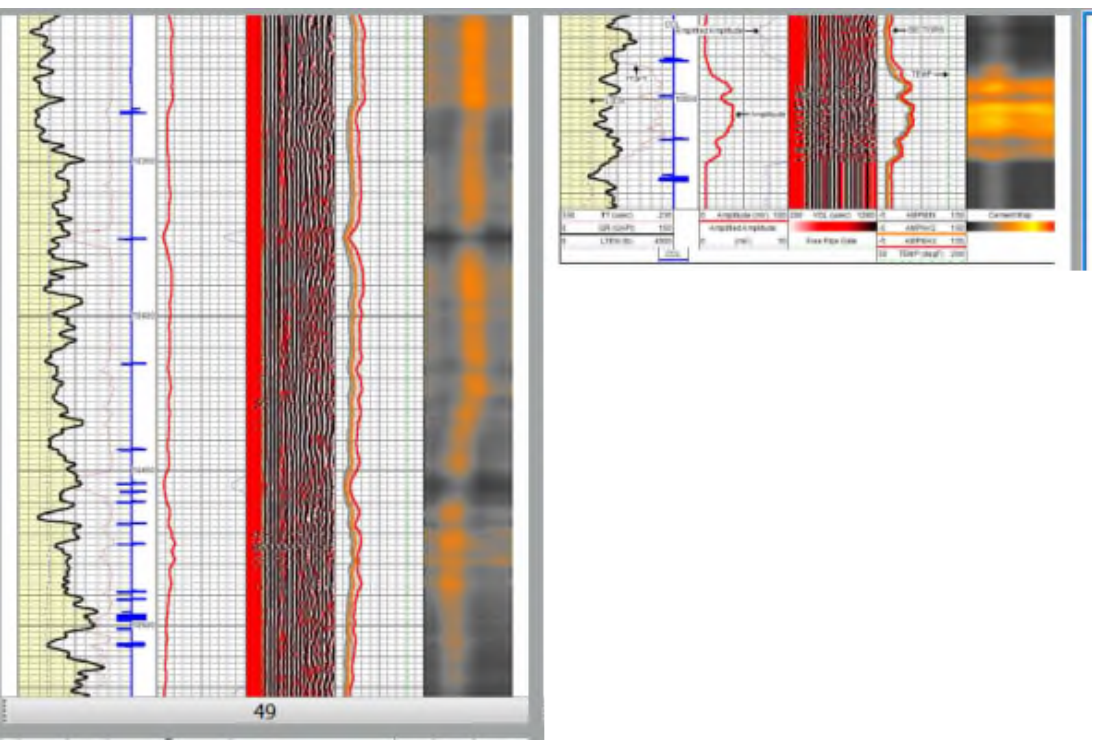

Max Allowable Surface Pressure (MASP) Table

	Column	1	2	3	4	5	6	7	8	9	10	11	12	13	14	15
	Calculation									$(1+6*7)/8$		$1/10$				$(1+12*13)/(12*14)$
API10	Well Name	Proposed Max Allowable Surface Pressure (MASP) (PSI)	Current Average Surface Pressure (PSI)	Max Achievable Surface Pressure, Current Infrastructure (PSI)	Proposed Average Injection Rate (MMSCFD)	Proposed Max Injection Rate (MMSCFD)	Burst Calculation Depth (FT TVD)	Brine Pressure Gradient (PSI/FT)	Casing or Liner Burst (PSI)	MASP + Reservoir Brine Hydrostatic as a percentage of Casing or Liner Burst Pressure (%)	Top Perforation Depth (FT TVD)	MASP Gradient (PSI/FT)	Top Perforation Depth (FT TVD)	Gas Pressure Gradient (PSI/FT)	Formation Parting Pressure Gradient (PSI/FT)	MASP + Gas Hydrostatic as a percentage of Formation Parting Pressure (%)
3002544101	MV-BS-1H-ST1	1,200	680	1,200	1.8	3.0	9,247	0.468	12,360	45%	9,247	0.130	9,247	0.200	0.650	51%
3002544196	MV-BS-2H	1,200	630	1,200	1.8	3.0	11,815	0.468	12,360	54%	11,815	0.102	11,815	0.200	0.650	46%
3002544183	MV-BS-3H	1,200	520	1,200	1.8	3.0	9,091	0.468	12,360	44%	9,091	0.132	9,091	0.200	0.650	51%
3002544064	MV-BS-4H	1,200	1100	1,200	1.8	3.0	10,359	0.468	12,360	49%	10,359	0.116	10,359	0.200	0.650	49%
3002544185	MV-BS-5H	1,200	1000	1,200	1.8	3.0	10,339	0.468	12,360	49%	10,339	0.116	10,339	0.200	0.650	49%
3002544042	MV-BS-6H	1,200	940	1,200	1.8	3.0	10,385	0.468	12,360	49%	10,385	0.116	10,385	0.200	0.650	49%

Wellhead Diagram

Tubing Flow, Casing Injection

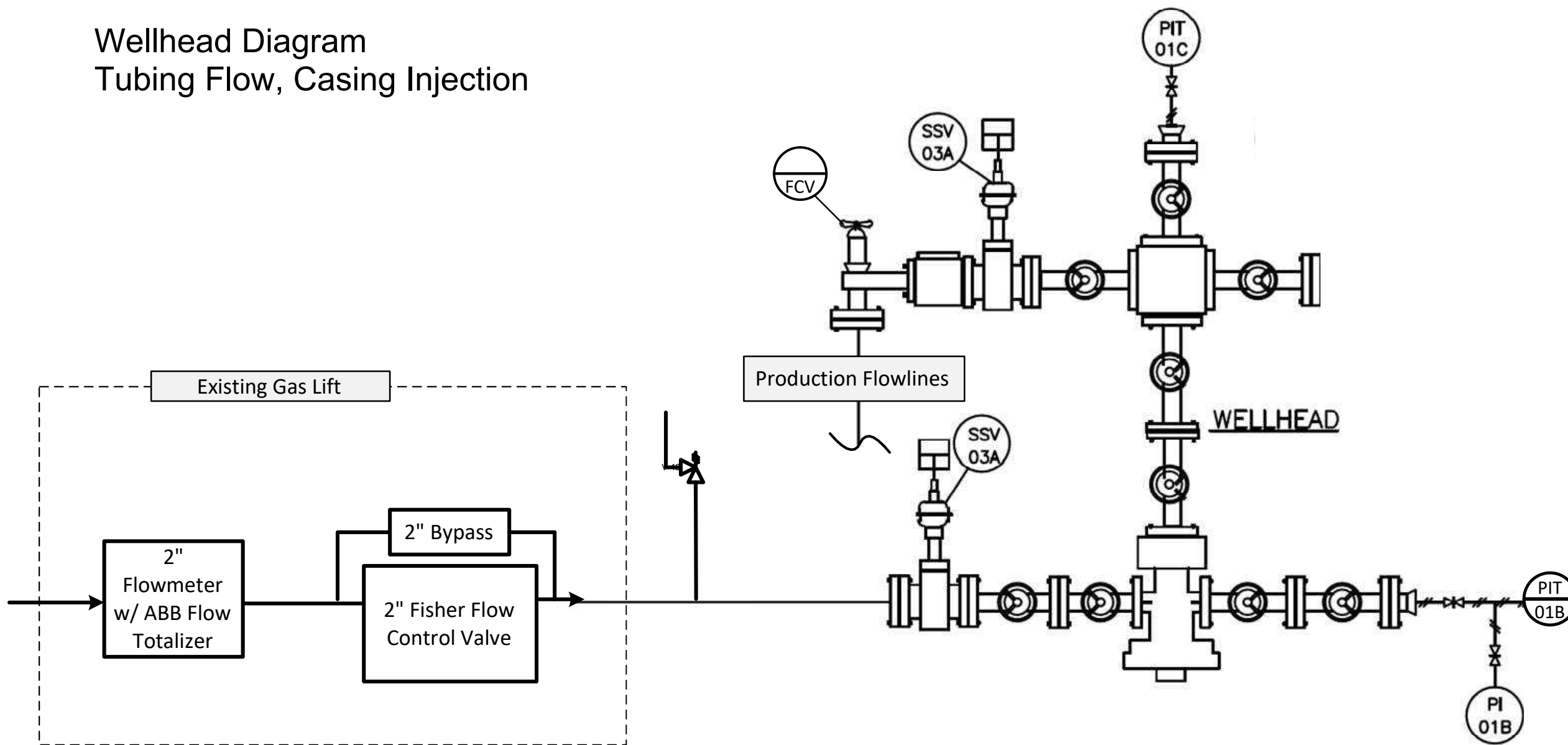

API 14	Well Name	Injection Down the...
30025441010100	MV-BS-1H-ST1	Casing
30025441830000	MV-BS-3H	Casing

KEY
SSV – Safety Shutdown Valve
PI – Pressure Indicator
PIT – Pressure Indicating Transmitter
FCV- Flow Control Valve

Wellhead Diagram

Casing Flow, Tubing Injection

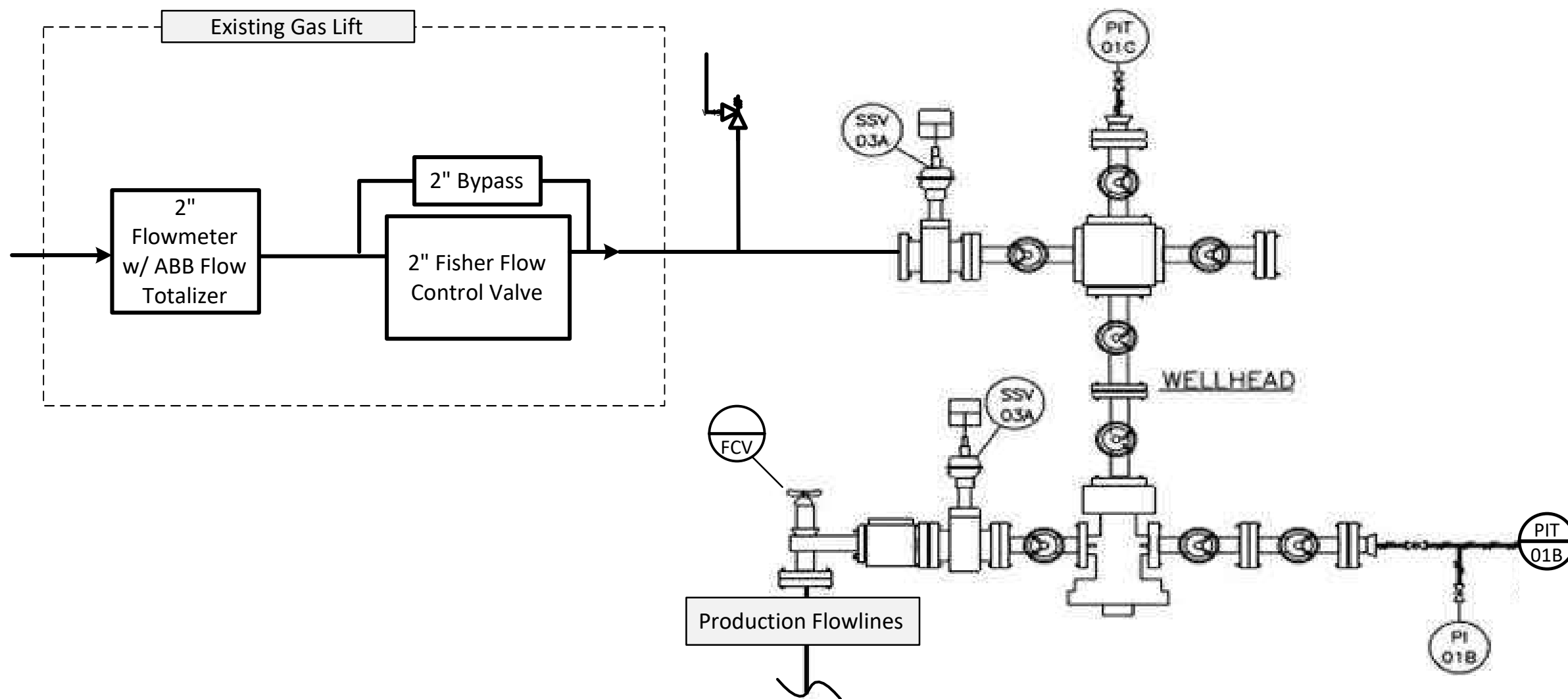

API 14	Well Name	Injection Down the...
30025441960000	MV-BS-2H	Tubing
30025440640000	Mesa Verde BS Unit 4H	Tubing
30025441850000	Mesa Verde BS Unit 5H	Tubing
30025440420000	Mesa Verde BS Unit 6H	Tubing

KEY
SSV – Safety Shutdown Valve
PI – Pressure Indicator
PIT – Pressure Indicating Transmitter
FCV- Flow Control Valve

Mechanical Integrity Test (MIT) Summary Table

API10	Well Name	MIT #1	
		Date	Details
3002544101	MV-BS-1H-ST1	5/26/2018	9800 psi for 30 mins
3002544196	MV-BS-2H	7/3/2018	9800 psi for 30 mins
3002544183	MV-BS-3H	7/2/2018	9800 psi for 30 mins
3002544064	MV-BS-4H	4/15/2018	9800 psi for 30 mins
3002544185	MV-BS-5H	4/15/2018	9800 psi for 30 mins
3002544042	MV-BS-6H	3/22/2018	9800 psi for 30 mins

Gas Analysis and Operations

Gas Source Well List

Name	Route Name	API 14
MESA VERDE BS UNIT 10H	SE_MESA VERDE ROUTE	30025441880000
MESA VERDE BS UNIT 11H	SE_MESA VERDE ROUTE	30025441870000
MESA VERDE BS UNIT 12H	SE_MESA VERDE ROUTE	30025441860000
MESA VERDE BS UNIT 13H	SE_MESA VERDE ROUTE	30025441920000
MESA VERDE BS UNIT 14H	SE_MESA VERDE ROUTE	30025441910000
MESA VERDE BS UNIT 15H	SE_MESA VERDE ROUTE	30025441900000
MESA VERDE BS UNIT 16H	SE_MESA VERDE ROUTE	30015445510000
MESA VERDE BS UNIT 17H	SE_MESA VERDE ROUTE	30015445500000
MESA VERDE BS UNIT 18H	SE_MESA VERDE ROUTE	30015445490000
MESA VERDE BS UNIT 19H	SE_MESA VERDE ROUTE	30015445480000
MESA VERDE BS UNIT 1H ST1	SE_MESA VERDE ROUTE	30025441010100
MESA VERDE BS UNIT 20H	SE_MESA VERDE ROUTE	30015445470000
MESA VERDE BS UNIT 21H	SE_MESA VERDE ROUTE	30015445460000
MESA VERDE BS UNIT 22H	SE_MESA VERDE ROUTE	30025445590000
MESA VERDE BS UNIT 23H	SE_MESA VERDE ROUTE	30025445600000
MESA VERDE BS UNIT 24H	SE_MESA VERDE ROUTE	30025445610000
MESA VERDE BS UNIT 2H	SE_MESA VERDE ROUTE	30025441960000
MESA VERDE BS UNIT 3H	SE_MESA VERDE ROUTE	30025441830000
MESA VERDE BS UNIT 4H	SE_MESA VERDE ROUTE	30025440640000
MESA VERDE BS UNIT 5H	SE_MESA VERDE ROUTE	30025441850000
MESA VERDE BS UNIT 6H	SE_MESA VERDE ROUTE	30025440420000
MESA VERDE BS UNIT 7H	SE_MESA VERDE ROUTE	30025440650000
MESA VERDE BS UNIT 8H	SE_MESA VERDE ROUTE	30025441840000
MESA VERDE BS UNIT 9H	SE_MESA VERDE ROUTE	30025441940000
MESA VERDE WC UNIT 10H	SE_MESA VERDE ROUTE	30025458720000
MESA VERDE WC UNIT 11H	SE_MESA VERDE ROUTE	30025458730000
MESA VERDE WC UNIT 1H ST1	SE_MESA VERDE ROUTE	30025441950100
MESA VERDE WC UNIT 2H	SE_MESA VERDE ROUTE	30025461100000
MESA VERDE WC UNIT 3H	SE_MESA VERDE ROUTE	30025461110000
MESA VERDE WC UNIT 4H	SE_MESA VERDE ROUTE	30025461120000
MESA VERDE WC UNIT 5H	SE_MESA VERDE ROUTE	30025458620000
MESA VERDE WC UNIT 6H	SE_MESA VERDE ROUTE	30025458630000
MESA VERDE WC UNIT 7H	SE_MESA VERDE ROUTE	30025459200000
MESA VERDE WC UNIT 8H	SE_MESA VERDE ROUTE	30025459210000
MESA VERDE WC UNIT 9H	SE_MESA VERDE ROUTE	30025458710000

Mesa Verde Gas Analysis Summary

- All producing wells go to 1 Central Tank Battery (CTB).
- There are 2 Compressor Gas Lift Stations (CGL's).
 - East CGL
 - West CGL
- The CGL's combine downstream in the same gas lift line to feed wells collectively.
- Gas analysis is provided for:
 1. East CGL injection
 2. West CGL injection
 3. Avalon production
 4. 2nd Bone Spring production
 5. 3rd Bone Spring production



Certificate of Analysis

Number: 6030-20110021-001A

Artesia Laboratory
 200 E Main St.
 Artesia, NM 88210
 Phone 575-746-3481

Chandler Montgomery
 Occidental Petroleum
 1502 W Commerce Dr.
 Carlsbad, NM 88220

Nov. 05, 2020

Field: Mesa Verde
 Station Name: Mesa Verde East CGL
 Station Number: N/A
 Sample Point: Inlet to Dehy
 Meter Number:
 County: Lea
 Type of Sample: Spot-Cylinder
 Heat Trace Used: N/A
 Sampling Method: Fill and Purge
 Sampling Company: OXY

Sampled By: Scott Beasley
 Sample Of: Gas Spot
 Sample Date: 10/30/2020 10:00
 Sample Conditions: 1290 psig, @ 60 °F Ambient: 45 °F
 Effective Date: 10/30/2020 10:00
 Method: GPA 2286
 Cylinder No: 1111-002316
 Instrument: 6030_GC2 (Agilent GC-7890B)
 Last Inst. Cal.: 08/25/2020 8:12 AM
 Analyzed: 11/05/2020 08:47:32 by PGS

Analytical Data

Components	Un-normalized Mol %	Mol. %	Wt. %	GPM at 14.65 psia		
Nitrogen	1.206	1.189	1.495		GPM TOTAL C2+	6.645
Methane	75.248	74.177	53.401		GPM TOTAL C3+	3.314
Carbon Dioxide	1.152	1.136	2.244		GPM TOTAL iC5+	0.562
Ethane	12.654	12.474	16.832	3.331		
Propane	6.662	6.567	12.995	1.806		
Iso-butane	0.889	0.876	2.285	0.286		
n-Butane	2.126	2.096	5.467	0.660		
Iso-pentane	0.443	0.437	1.415	0.159		
n-Pentane	0.488	0.481	1.557	0.174		
Hexanes Plus	0.575	0.567	2.309	0.229		
	101.443	100.000	100.000	6.645		

Calculated Physical Properties

	Total	C6+
Relative Density Real Gas	0.7722	3.1348
Calculated Molecular Weight	22.28	90.79
Compressibility Factor	0.9960	

GPA 2172 Calculation:

Calculated Gross BTU per ft³ @ 14.65 psia & 60°F

Real Gas Dry BTU	1298	4897
Water Sat. Gas Base BTU	1275	4811
Ideal, Gross HV - Dry at 14.65 psia	1292.6	4896.9
Ideal, Gross HV - Wet	1270.0	0.000
Net BTU Dry Gas - real gas	1179	
Net BTU Wet Gas - real gas	1158	

Comments: H2S Field Content 0 ppm

Hydrocarbon Laboratory Manager

Quality Assurance: The above analyses are performed in accordance with ASTM, UOP, GPA guidelines for quality assurance, unless otherwise stated.



Certificate of Analysis

Number: 6030-20110020-001A

Artesia Laboratory
 200 E Main St.
 Artesia, NM 88210
 Phone 575-746-3481

Chandler Montgomery
 Occidental Petroleum
 1502 W Commerce Dr.
 Carlsbad, NM 88220

Nov. 05, 2020

Field: Mesa Verde
 Station Name: Mesa Verde West CGL
 Station Number: N/A
 Sample Point: Inlet to Dehy
 Meter Number:
 County: Lea
 Type of Sample: Spot-Cylinder
 Heat Trace Used: N/A
 Sampling Method: Fill and Purge
 Sampling Company: OXY

Sampled By: Scott Beasley
 Sample Of: Gas Spot
 Sample Date: 10/30/2020 10:26
 Sample Conditions: 1298 psig, @ 60 °F Ambient: 50 °F
 Effective Date: 10/30/2020 10:26
 Method: GPA 2286
 Cylinder No: 1111-002622
 Instrument: 6030_GC2 (Agilent GC-7890B)
 Last Inst. Cal.: 08/25/2020 8:12 AM
 Analyzed: 11/05/2020 08:47:32 by PGS

Analytical Data

Components	Un-normalized Mol %	Mol. %	Wt. %	GPM at 14.65 psia		
Nitrogen	1.166	1.155	1.435		GPM TOTAL C2+	6.844
Methane	74.265	73.590	52.342		GPM TOTAL C3+	3.505
Carbon Dioxide	1.155	1.145	2.234		GPM TOTAL iC5+	0.642
Ethane	12.617	12.502	16.667	3.339		
Propane	6.809	6.747	13.190	1.856		
Iso-butane	0.931	0.923	2.378	0.302		
n-Butane	2.260	2.239	5.770	0.705		
Iso-pentane	0.483	0.479	1.532	0.174		
n-Pentane	0.540	0.535	1.711	0.193		
Hexanes Plus	0.691	0.685	2.741	0.275		
	100.917	100.000	100.000	6.844		

Calculated Physical Properties

	Total	C6+
Relative Density Real Gas	0.7816	3.1056
Calculated Molecular Weight	22.56	89.95
Compressibility Factor	0.9959	

GPA 2172 Calculation:

Calculated Gross BTU per ft³ @ 14.65 psia & 60°F

Real Gas Dry BTU	1313	4842
Water Sat. Gas Base BTU	1290	4757
Ideal, Gross HV - Dry at 14.65 psia	1307.1	4841.9
Ideal, Gross HV - Wet	1284.2	0.000
Net BTU Dry Gas - real gas	1193	
Net BTU Wet Gas - real gas	1172	

Comments: H2S Field Content 0 ppm

Hydrocarbon Laboratory Manager

Quality Assurance: The above analyses are performed in accordance with ASTM, UOP, GPA guidelines for quality assurance, unless otherwise stated.

Atchafalaya Measurement Inc
 416 East Main Street, Artesia NM 88210 575-746-3481

Sample Information

Sample Information	
Sample Name	OXY__Mesa Verde BS Unit 3H__GC2-82018-02
Station Number	Flowback
Lease Name	Mesa Verde BS Unit 3H
Analysis For	OXY USA
Producer	OXY USA
Field Name	Buck Jackson
County/State	Lea,NM
Frequency/Spot Sample	Spot
Sampling Method	Fill Empty
Sample Deg F	118
Atmos Deg F	85
Flow Rate	N/A
Line PSIG	319
Date Sampled/Time Sampled	8-17-18
Cylinder Number	N/A
Cylinder Clean Date	N/A
Sampled By	Jesus Escobedo
Analysis By	Pat Silvas
Verified/Calibrated Date	8-20-18
Report Date	2018-08-20 10:39:27

Component Results

Component Name	Ret. Time	Peak Area	Norm%	GPM (Dry) (Gal. / 1000 cu.ft.)
Nitrogen	22.800	24973.4	1.8396	0.000
H2S	0.000	0.0	0.0000	0.000
Methane	23.600	698935.5	68.1431	0.000
Carbon Dioxide	27.080	209818.6	13.2389	0.000
Ethane	37.160	163408.0	9.6436	2.574
Propane	77.960	106434.1	4.7467	1.305
i-Butane	29.820	45025.0	0.5476	0.179
n-Butane	32.140	91966.3	1.1101	0.349
i-Pentane	39.160	21654.3	0.2272	0.083
n-Pentane	41.980	20315.7	0.2075	0.075
C6's	50.750	14074.0	0.1264	0.052
C7's	67.000	12630.0	0.1092	0.050
C8's	84.000	5490.0	0.0506	0.026
C9's	102.000	2339.0	0.0078	0.004
C10 Plus	146.000	453.0	0.0017	0.001
Total:			100.0000	4.698

Results Summary

Result	Dry	Sat. (Base)
Total Raw Mole% (Dry)	101.7267	
Pressure Base (psia)	14.650	
Temperature Base	60.00	
Gross Heating Value (BTU / Ideal cu.ft.)	1062.3	1043.7
Gross Heating Value (BTU / Real cu.ft.)	1066.2	1048.0
Relative Density (G), Ideal	0.8228	0.8193
Relative Density (G), Real	0.8255	0.8223
Compressibility (Z) Factor	0.9963	0.9959

Atchafalaya Measurement, Inc.

416 East Main Street Artesia, NM 88210 575-746-3481

Sample Information

Sample Information	
Sample Name	OXY__Mesa Verde Bone Springs Unit 5__GC1-51518-01
Station Number	TestSkid
Lease Name	Mesa Verde Bone Springs Unit 5
Analysis For	OXY USA
Producer	OXY USA
Field Name	Buck Jackson
County	Lea
State	NM
Frequency	Spot
Sample Deg F	113.4
Atmos Deg F	21
Flow Rate	1042.8
Line PSIG	150
Date Sampled	5-14-18
Sampled By	Chris Myers
Analysis By	Pat Silvas
Report Date	2018-05-15 07:10:56

Component Results

Component Name	Ret. Time	Peak Area	Norm%	PPMV	GPM (Dry) (Gal. / 1000 cu.ft.)
Nitrogen	22.140	12765.6	2.46691	24669.100	0.271
H2S	46.000	0.0	0.00000	0.000	0.000
Methane	22.980	291616.0	72.46222	724622.200	12.262
Carbon Dioxide	26.760	1153.2	0.18673	1867.300	0.032
Ethane	37.000	95357.5	14.16976	141697.600	3.783
Propane	79.160	63791.5	7.06172	70617.200	1.942
i-butane	28.780	56723.6	0.81633	8163.300	0.267
n-Butane	30.360	140567.7	1.94913	19491.300	0.613
i-pentane	35.520	28166.3	0.33133	3313.300	0.121
n-Pentane	37.620	26425.6	0.30257	3025.700	0.109
Hexanes Plus	120.000	22572.0	0.25330	2533.000	0.110
Total:			100.00000	1000000.000	19.510

Results Summary

Result	Dry	Sat. (Base)
Total Raw Mole% (Dry)	101.85248	
Total Amount PPM (Mole/Vol.)	1000000.000	
Pressure Base (psia)	14.650	
Temperature Base	60.00	
Gross Heating Value (BTU / Ideal cu.ft.)	1284.8	1262.3

Atchafalaya Measurement Inc
 416 East Main Street, Artesia NM 88210 575-746-3481

Sample Information

Sample Information	
Sample Name	OXY__Mesa Verde 2H__GC2-41619-10
Station Number	15504T
Lease Name	Mesa Verde 2H
Analysis For	OXY USA
Producer	OXY USA
Field Name	Basin
County/State	Eddy,NM
Frequency/Spot Sample	Quarterly
Sampling Method	Fill Empty
Sample Deg F	86.5
Atmos Deg F	60
Flow Rate	1575.9771
Line PSIG	112.4
Date Sampled/Time Sampled	4-11-19
Cylinder Number	N/A
Cylinder Clean Date	N/A
Sampled By	Victor Urias
Analysis By	Pat Silvas
Verified/Calibrated Date	4-15-19
Report Date	2019-04-16 14:03:56

Component Results

Component Name	Ret. Time	Peak Area	Norm%	GPM (Dry) (Gal. / 1000 cu.ft.)
Nitrogen	22.960	21911.2	1.6270	0.000
H2S	0.000	0.0	0.0000	0.000
Methane	23.740	732471.0	71.9846	0.000
Carbon Dioxide	27.640	44300.2	2.8176	0.000
Ethane	36.960	211191.6	12.5633	3.354
Propane	77.160	149546.1	6.7228	1.849
i-Butane	29.820	71692.4	0.8789	0.287
n-Butane	32.080	168721.6	2.0529	0.646
i-Pentane	39.180	40565.8	0.4290	0.157
n-Pentane	41.980	44912.8	0.4623	0.167
C6's	50.750	26514.0	0.2401	0.099
C7's	67.000	19009.0	0.1657	0.076
C8's	84.000	5233.0	0.0486	0.025
C9's	102.000	1531.0	0.0051	0.003
C10 Plus	146.000	557.0	0.0021	0.001
Total:			100.0000	6.664

Results Summary

Result	Dry	Sat. (Base)
Total Raw Mole% (Dry)	100.9186	
Pressure Base (psia)	14.650	
Temperature Base	60.00	
Gross Heating Value (BTU / Ideal cu.ft.)	1269.9	1247.7
Gross Heating Value (BTU / Real cu.ft.)	1275.0	1253.2
Relative Density (G), Ideal	0.7862	0.7833
Relative Density (G), Real	0.7891	0.7865
Compressibility (Z) Factor	0.9960	0.9955

Corrosion Prevention Plan

Existing Corrosion Prevention Plan

- Produced gas is processed through a gas dehydration unit to remove water.
- Corrosion inhibitor is added to the system downstream of the gas dehydration unit.
- Fluid samples are taken regularly and checked for Fe, Mn, and residual corrosion inhibitor in produced fluids.
- Continuously monitor and adjust the chemical treatment over the life of the well.

Oxy will continue the existing corrosion prevention plan in place for the gas lift system due to the similar nature of gas storage operations.

- Fluid samples will be taken prior to injection to establish a baseline for analysis.
- After a storage event, fluid samples will be taken to check for Fe, Mn, and residual corrosion inhibitor in the produced fluids.
- Continuously monitor and adjust the chemical treatment over the life of the project.



NM GAS STORAGE OPERATIONAL PLAN

Operational Plan

WELLSITE CLGC

Oxy USA Inc. (Oxy) will monitor the following items on each Closed Loop Gas Capture (CLGC) well via SCADA system:

- Injection flow rate and volume
 - Instantaneous Rate
 - Total Injected by Day (volume)
- Tubing Pressure
- Casing Pressure
- Bradenhead Pressures
- Safety devices
 - Pressure kills have an automated kill sequence that is initiated by SCADA system readings.
 - Injection pressure kills on production stream for injection
 - Relief Valves for both production and gas storage/injection streams to prevent overpressure (not monitored via SCADA other than pressure trend)
 - Control of injection rate and pressures via control valve at each well injection stream
 - Control of production stream via automated choke valves to ensure controlled production and prevent over pressurization of flowline

CENTRAL TANK BATTERY (CTB)

Oxy will monitor the following items at each CTB via SCADA system:

- Production Rates
 - Oil
 - Gas
 - Water
- Safety devices
 - Flares at CTBs
 - Injection pressure kills on production/gas storage stream for injection
 - Emergency Shutdown (ESD) of wells that are local and remote for automatic shut downs to safe the system
 - Control of injection rate and pressures via control valve at each well injection stream

CENTRAL GAS LIFT (CGL) COMPRESSOR(S)

Oxy will monitor the following items on each Central Gas Lift (CGL) Compressor Station via SCADA system:

- Safety devices
 - Discharge/injection pressure kills of each compressor and for the station
 - Relief Valves on 3rd stage of compressors, to prevent over pressurization (not monitored via SCADA other than pressure trend)
 - Station recycle valves (that recycle discharge pressure back to suction) if the pressure is getting too high for the compressor or station. (not all control valves are capable of

remote monitoring of valve position; but still monitored in some sense of the pressure trend for the station)

SUPERVISORY CONTROL AND DATA ACQUISITION (SCADA)

Oxy SCADA system consists of PLCs at each CTB, Wellsite, and Central Gas Lift compressor or station.

- The Programmable Logic Controller (PLCs) will take action immediately (within seconds or minutes) as programmed to automatically safe the system as required; for the system and certain device shut down(s).
- The High Alarms and High-High Alarms will be logged and registered in the SCADA system. Also the call center will take the High Alarm and make the physical phone call notification to the production techs to acknowledge the alarm & take action.

ENVIRONMENTAL/SPILL RESPONSE

Oxy will report and track any spill recordable or non-recordable via our CDR system

- Any spill or gas release will be reported by operations calling in to our Call Center to make the report of spill/release. The fluid type and release amount will be disclosed along with location details; and if it's a recordable or non-recordable spill.
- Liquids will be contained and isolated and vacuum trucks will be called in to recover the liquid and will also report the amount of liquid recovered on the same CDR spill form.
 - Additional reclamation will be coordinated to ensure proper recovery of contaminated soil and liquid.

Area of Review

Mesa Verde 2 Mile Map

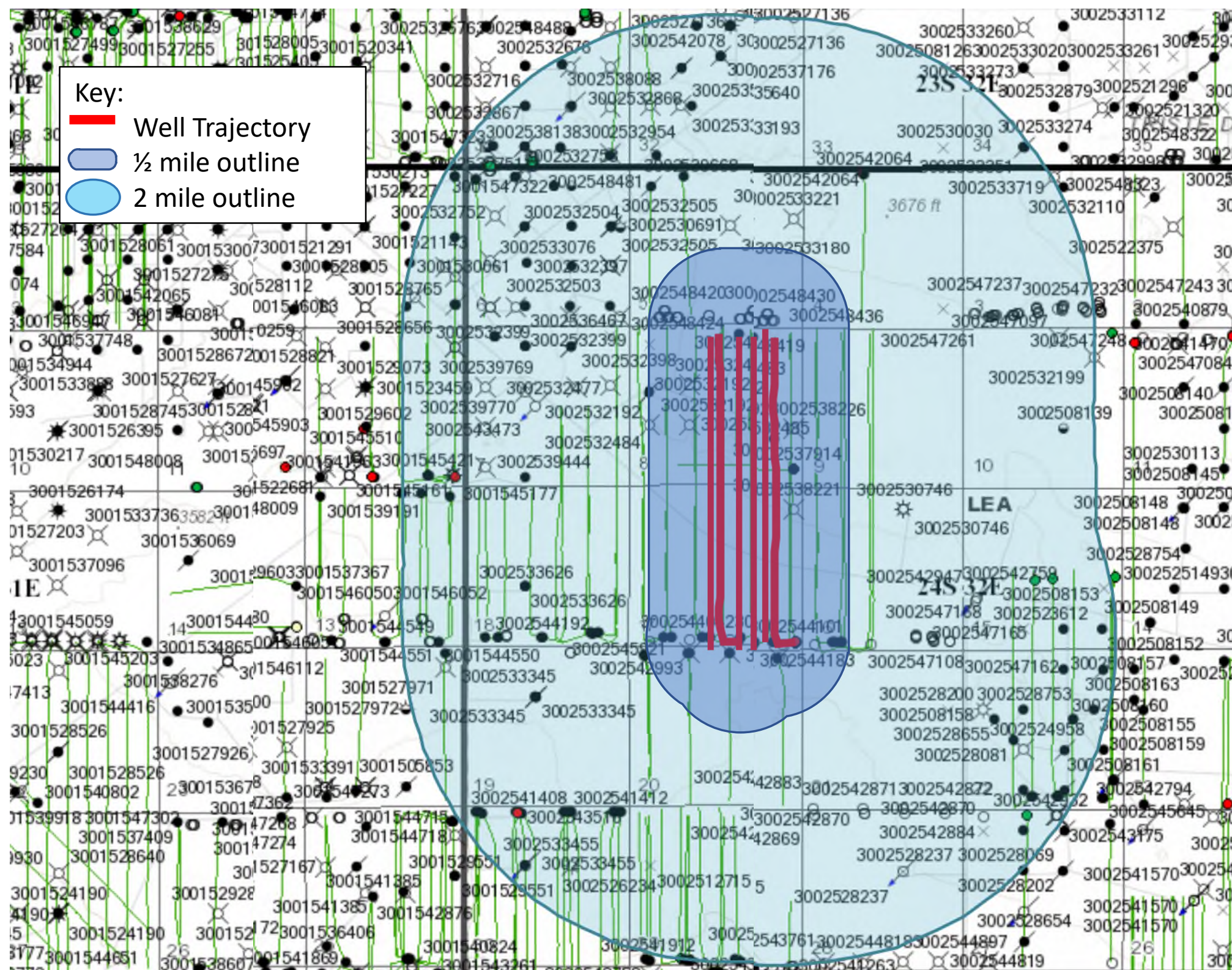



MESA VERDE NEW MEXICO

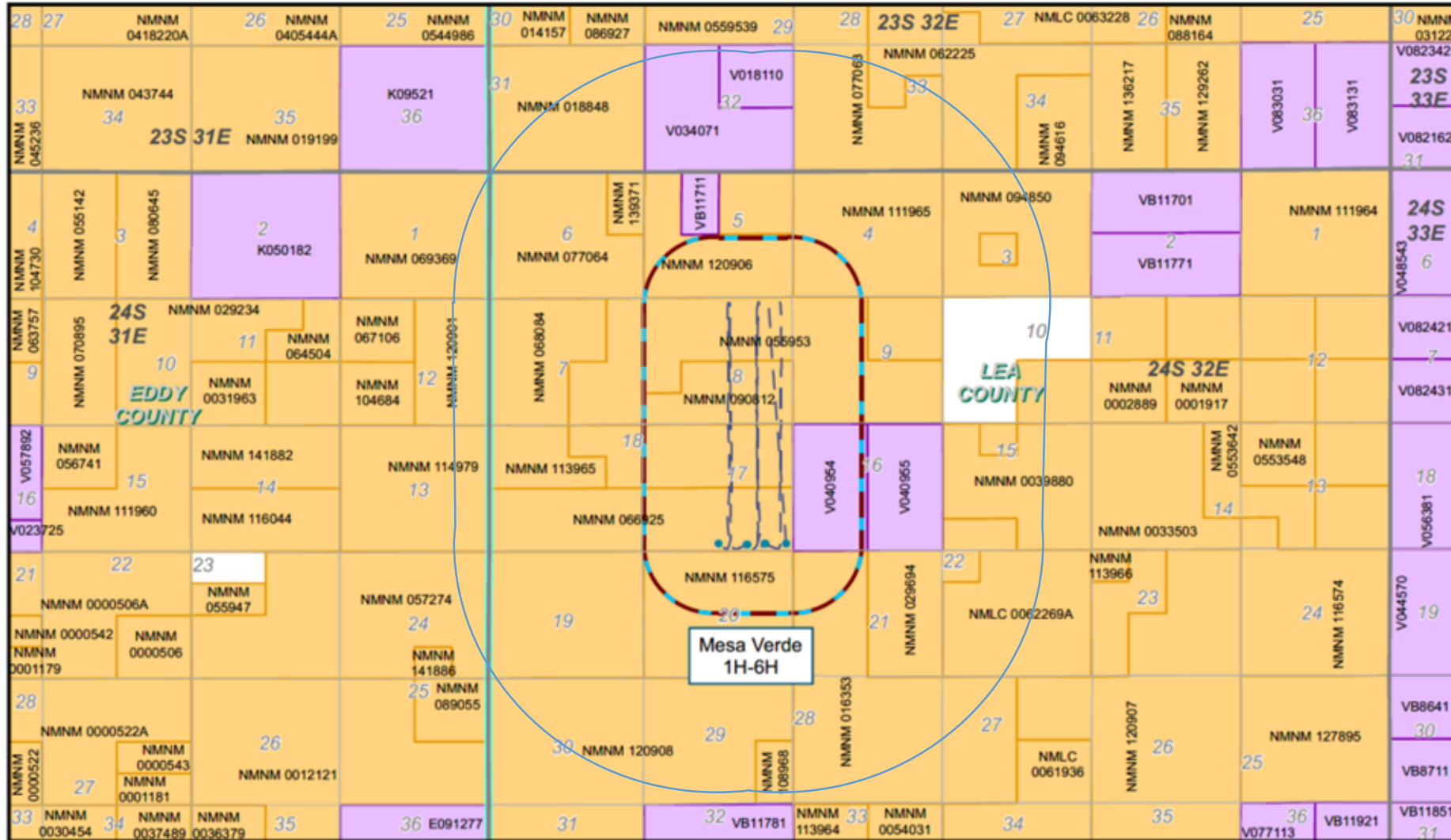

- County
- 1/2 mile AOR
- Surface Hole Location
- Wellbore Trajectory
- Lease Owner Type: Federal
- State
- 2-mile Outline

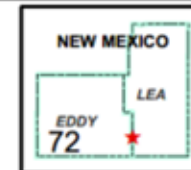
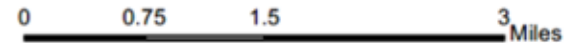

Mesa Verde AOR Map

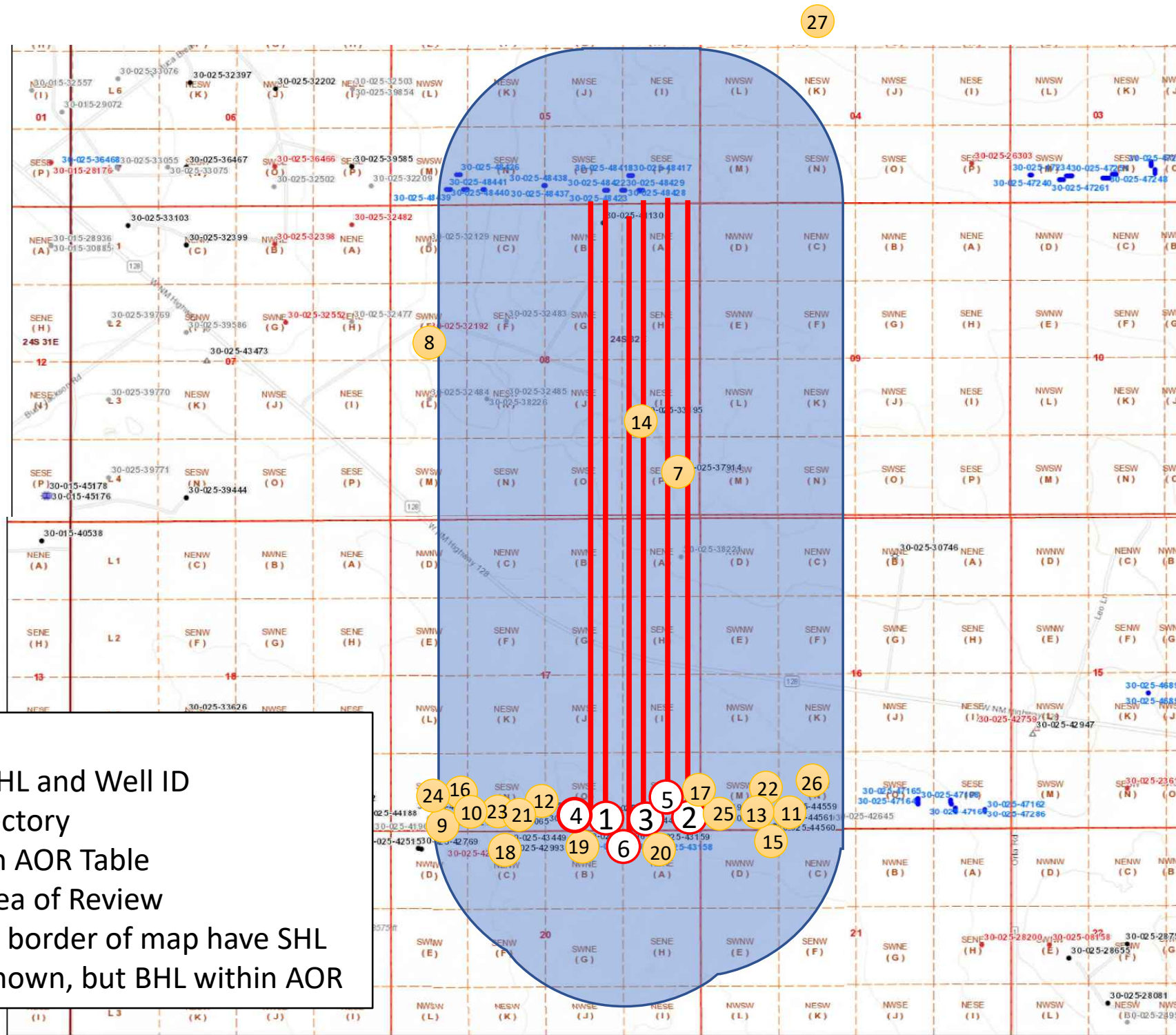

Key:

- Injector SHL and Well ID
- Well Trajectory
- Well ID on AOR Table
- ½ mile Area of Review

*Wells outside border of map have SHL outside map shown, but BHL within AOR

4/14/2021, 3:30:51 PM

Wells - Large Scale	Gas, Active	Injection, Plugged	Salt Water Injection, Cancelled	Water, Temporarily Abandoned
7 undefined	Gas, Cancelled	Injection, Temporarily Abandoned	Salt Water Injection, New	OCD District Offices
Miscellaneous	Gas, New	Oil, Active	Salt Water Injection, Plugged	PLSS First Division
CO2, Active	Gas, Plugged	Oil, Cancelled	Salt Water Injection, Temporarily Abandoned	PLSS Second Division
CO2, Cancelled	Gas, Temporarily Abandoned	Oil, New	Water, Active	PLSS Townships
CO2, New	Injection, Active	Oil, Plugged	Water, Cancelled	
CO2, Plugged	Injection, Cancelled	Oil, Temporarily Abandoned	Water, New	
CO2, Temporarily Abandoned	Injection, New	Salt Water Injection, Active	Water, Plugged	

1:18,056

0 0.17 0.35 0.7 mi

0 0.3 0.6 1.2 km

Oil Conservation Division of the New Mexico Energy, Minerals and Natural Resources Department, Bureau of Land Management, Texas Parks & Wildlife, Esri, HERE, Garmin, INCREMENT P, USGS, METI/NASA, EPA, USDA, OCD, BLM

New Mexico Oil Conservation Division

NM OCD Oil and Gas Map. <http://nm-emnrd.maps.arcgis.com/apps/webappviewer/index.html?id=4d0172306164de29fd2fb98f935ca75>; New Mexico Oil Conservation Division

Mesa Verde AOR Table

Well ID	API NUMBER	Current Operator	LEASE NAME	WELL NUMBER	Well Type:	Status:	Footages		Surface Location				Spud [date]	True		Measured Depth [ft]	HOLE SIZE		CSG SIZE		CMT TO		Current Completion [ft]	Comment	Current Producing Pool
							N/S	N/S	E/W	E/W	Unit	Section		TShip	Range		Depth [ft]	Depth [ft]	[in]	[in]	SET AT	SX CMT			
1	30-025-44183	OXY USA INC	MESA VERDE BONE SPRING UNIT	003H	Oil	Active	240 S	1644 E	O		17 24S	32E	2/5/2018	9125	19320	17.5	13.375	954	1220	Surf	Circ	9253-19155	[96229] MESA VERDE; BONE SPRING		
2	30-025-44101	OXY USA INC	MESA VERDE BONE SPRING UNIT	001H	Oil	Active	271 S	245 E	P		17 24S	32E	12/27/2017	9291	19366	17.5	13.375	918	1264	Surf	Circ	9451-19251	well is side tracked. Whipstock at 7013' in 9.625" casing. [96229] MESA VERDE; BONE SPRING		
3	30-025-44196	OXY USA INC	MESA VERDE BONE SPRING UNIT	002H	Oil	Active	240 S	1614 E	O		17 24S	32E	2/3/2018	11861	22095	17.5	13.375	938	1202	Surf	Circ	12165-21916	[96229] MESA VERDE; BONE SPRING		
4	30-025-44042	OXY USA INC	MESA VERDE BONE SPRING UNIT	006H	Oil	Active	280 S	2624 E	O		17 24S	32E	1/6/2018	10411	20454	17.5	13.375	939	1240	Surf	Circ	10739-20223	[96229] MESA VERDE; BONE SPRING		
5	30-025-44064	OXY USA INC	MESA VERDE BONE SPRING UNIT	004H	Oil	Active	280 S	965 E	P		17 24S	32E	1/25/2018	10447	20545	17.500	13.375	952	1712	Surf	Circ	10483-20385	[96229] MESA VERDE; BONE SPRING		
6	30-025-44185	OXY USA INC	MESA VERDE BONE SPRING UNIT	005H	Oil	Active	280 S	995 E	P		17 24S	32E	1/29/2018	10449	20505	17.500	13.375	974	1245	Surf	Circ	10441-20343	[96229] MESA VERDE; BONE SPRING		
7	30-025-37914	OXY USA INC	MESA VERDE 8 FEDERAL	002H	Oil	Active	660 S	330 E	P		8 24S	32E	8/1/2006	9764	12900	17.500	13.375	850	745	Surf	Circ	10152-12710	[96229] MESA VERDE; BONE SPRING		
8	30-025-32192	EOG RESOURCES INC	JACK TANK 8 FEDERAL	002	Oil	PA	2180 N	660 W	E		8 24S	32E	9/10/1993	15460	15460	12.250	9.625	4694	1290	Surf	Circ	NA	NA		
9	30-025-44194	OXY USA INC	MESA VERDE BONE SPRING UNIT	009H	Oil	Active	280 S	1116 W	M		17 24S	32E	1/22/2018	10392	20504	17.5	13.375	952	1230	Surf	Circ	10400-20277	[96229] MESA VERDE; BONE SPRING		
10	30-025-44184	OXY USA INC	MESA VERDE BONE SPRING UNIT	008H	Oil	Active	280 S	1146 W	M		17 24S	32E	1/20/2018	10403	20430	17.5	13.375	957	1235	Surf	Circ	10400-20277	[96229] MESA VERDE; BONE SPRING		
11	30-025-44561	OXY USA INC	MESA VERDE BONE SPRING UNIT	024H	Oil	Active	250 S	1225 W	M		16 24S	32E	6/10/2018	10426	20812	17.5	13.375	970	1254	Surf	Circ	10338-20691	[96229] MESA VERDE; BONE SPRING		
12	30-025-44065	OXY USA INC	MESA VERDE BONE SPRING UNIT	007H	Oil	Active	280 S	2626 W	N		17 24S	32E	1/3/2018	10429	20541	17.5	13.375	935	1240	Surf	Circ	10619-20370	[96229] MESA VERDE; BONE SPRING		
13	30-025-44559	OXY USA INC	MESA VERDE BONE SPRING UNIT	022H	Oil	Active	250 S	1285 W	M		16 24S	32E	6/6/2018	10522	20815	17.5	13.375	964	1254	Surf	Circ	10565-20668	[96229] MESA VERDE; BONE SPRING		
14	30-025-33195	OXY USA INC	NAFTA 8 FEDERAL	001	Oil	PA	1650 S	990 E	I		8 24S	32E	4/16/1997	10000	10000	17.5	13.375	650	725	Surf	Circ	NA	NA		
15	30-025-44560	OXY USA INC	MESA VERDE BONE SPRING UNIT	023H	Oil	Active	250 S	1255 W	M		16 24S	32E	6/8/2018	10812	21115	17.5	13.375	970	1254	Surf	Circ	10648-21001	[96229] MESA VERDE; BONE SPRING		
16	30-025-45921	OXY USA INC	MESA VERDE WOLFCAMP UNIT	008H	Oil	Active	280 S	1386 W	N		17 24S	32E	5/26/2019	12016	22337	14.75	10.750	950	970	Surf	Circ	12137-22239	[98252] MESA VERDE; WOLFCAMP		
17	30-025-44195	OXY USA INC	MESA VERDE WOLFCAMP UNIT	001H	Oil	Active	241 S	245 E	P		17 24S	32E	12/30/2017	12054	22281	17.5	13.375	922	1190	Surf	Circ	12240-22116	[98252] MESA VERDE; WOLFCAMP		
18	30-025-43449	DEVON ENERGY PRODUCTION COMPANY, LP	REBEL 20 FEDERAL	006Y	Oil	Active	250 N	1970 W	C		20 24S	32E	1/17/2018	10411	15347	17.5	13.375	920	1205	Surf	Circ	10656-14961	[96556] COTTON DRAW; BONE SPRING, EAST		
19	30-025-42996	DEVON ENERGY PRODUCTION COMPANY, LP	REBEL 20 FEDERAL	007H	Oil	Active	230 N	1980 E	B		20 24S	32E	5/15/2017	10799	15529	17.5	13.375	911	1040	Surf	Circ	10982-15328	[96556] COTTON DRAW; BONE SPRING, EAST		
20	30-025-43159	DEVON ENERGY PRODUCTION COMPANY, LP	REBEL 20 FEDERAL	008H	Oil	Active	250 N	870 E	A		20 24S	32E	6/9/2017	10787	15630	17.500	13.375	913	960	Surf	Circ	8536-15496	[96556] COTTON DRAW; BONE SPRING, EAST		
21	30-025-45863	OXY USA INC	MESA VERDE WOLFCAMP UNIT	006H	Oil	Active	280 S	2401 W	N		17 24S	32E	5/16/2019	12067	22341	14.750	10.750	942	908	Surf	Circ	12157-22218	[98252] MESA VERDE; WOLFCAMP		
22	30-025-46111	OXY USA INC	MESA VERDE WOLFCAMP UNIT	003H	Oil	Active	250 S	1000 W	M		16 24S	32E	11/29/2019	12087	22371	14.75	10.750	890	975	Surf	Circ	12270-22288	[98252] MESA VERDE; WOLFCAMP		
23	30-025-45862	OXY USA INC	MESA VERDE WOLFCAMP UNIT	005H	Oil	Active	280 S	2436 W	N		17 24S	32E	5/18/2019	12211	22505	14.75	10.750	942	908	Surf	Circ	12327-22387	[98252] MESA VERDE; WOLFCAMP		
24	30-025-45920	OXY USA INC	MESA VERDE WOLFCAMP UNIT	007H	Oil	Active	280 S	1421 W	N		17 24S	32E	5/25/2019	12211	22458	14.75	10.750	934	970	Surf	Circ	12047-22108	[98252] MESA VERDE; WOLFCAMP		
25	30-025-46112	OXY USA INC	MESA VERDE WOLFCAMP UNIT	004H	Oil	Active	250 S	965 W	M		16 24S	32E	8/31/2020	12225	22563	14.75	10.750	941	975	Surf	Circ	12668-22488	[98252] MESA VERDE; WOLFCAMP		
26	30-025-46110	OXY USA INC	MESA VERDE WOLFCAMP UNIT	002H	Oil	Active	250 S	1035 W	M		16 24S	32E	11/25/2019	12280	22607	14.75	10.750	959	975	Surf	Circ	12395-22413	[98252] MESA VERDE; WOLFCAMP		

Mesa Verde AOR Table

27 30-025-42064	COG OPERATING LLC	MASTIFF FEDERAL	003H	Oil	Active	190 N	1980 W	C	4 24S	32E	9/6/2015	10652	15020	9.875	7.625	11725	3015	190	Calc		
														6.75	5.500	22585	855	5618	Calc		
														17.500	13.375	1263	1000	Surf	Circ	10757-14920	[96229] MESA VERDE; BONE SPRING
														12.250	9.625	4850	1580	Surf	Circ		
														8.750	5.500	15020	2215	2140	CBL		

Well ID #8 in AOR

1/4/2021

Current Wellbore
Jack Tank 8 Federal #2
 30-025-32192-0000
 Lea

String 1
 OD 20 in
 TD 598 ft
 TOC 0 ft
 932 sx, circ

String 2
 OD 13.375 in
 TD 4521 ft
 TOC 0 ft
 4500 sx, circ

String 3
 OD 9.625 in
 TD 12108 ft
 TOC 4500 ft
 3625 sx, Temp Survey

String 4, liner
 OD 7 in
 11768'-14950'
 750 sxs

String 5, liner
 OD 4.5 in
 14656'-15452'
 200 sxs

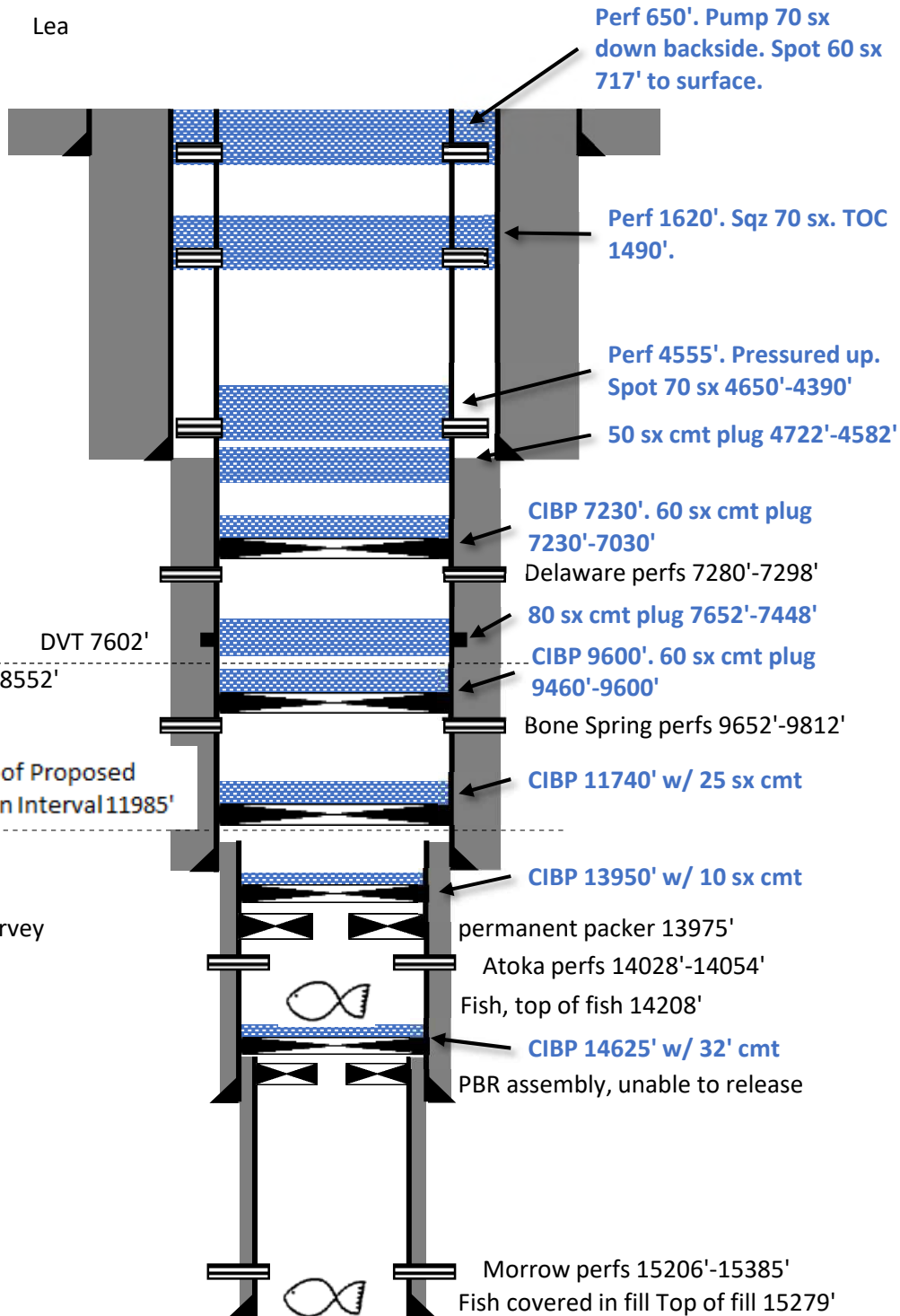

WELL ID #14 IN AOR

NAFTA 8 Federal 1

30-025-33195-0000

Lea

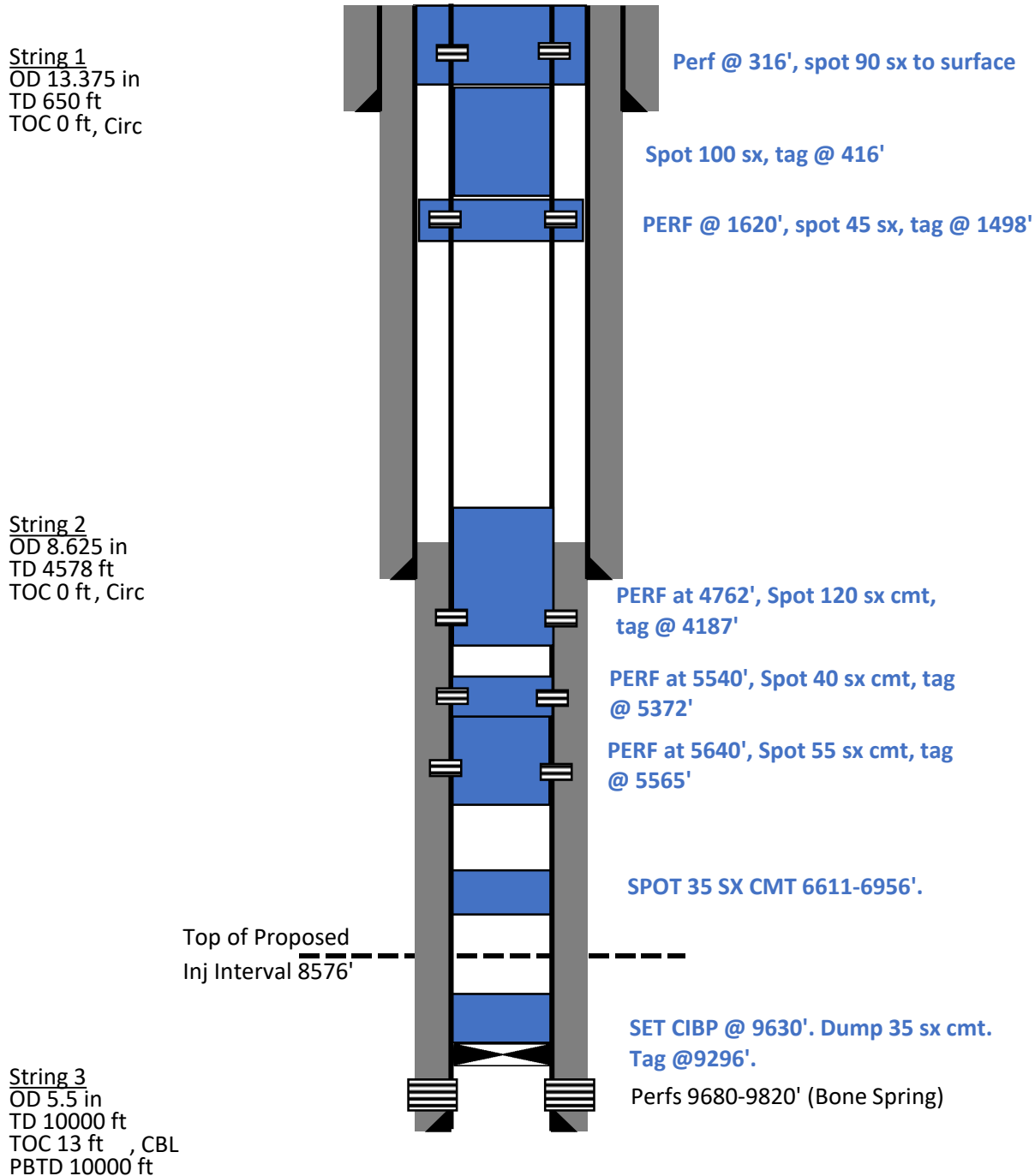

Geology

Mesa Verde Type Log

MESA VERDE WC/BS 1H Combined					
Operator: OXY USA INC					
Well datum value: 3585.7 ft TD (MD): 14150.0 ft					
XGR	TVD	MD	XRESO	XNPHIL	Lime
0.00 gAPI 150.00			0.0000 g/m3 2.0000000	0.3000 -0.1000	Sand
XCAL			XRESS	XPEF	Clay
6.0 in 16.0			0.0000 g/m3 2.0000000	0.00 0.00 20.00	
Gamma Ray				XRHOB	
				6.00 g/cm3 3.00	

MESA VERDE WC/BS UNIT 1H_PILOTcombined					
Operator: OXY USA INC					
Well datum value: 3585.7 ft TD (MD): 14150.0 ft					
XGR	TVD	XRESO	XNPHIL	Lime	
0.00 gAPI 150.00		0.0000 g/m3 2.0000000	0.3000 -0.1000	Sand	
XCAL		XRESS	XPEF	Clay	
6.0 in 16.0		0.0000 g/m3 2.0000000	0.00 0.00 20.00		
Gamma Ray			XRHOB		
			2.00 g/cm3 3.00		

Barriers protecting fresh water

- Rustler
- Salado Salt (~2,000ft thick)
- Castile Formation (~1,400ft thick)
 - > Low permeability anhydrite, gypsum, and calcite
- Delaware Mountain Group (~3,900ft thick)
 - > Low porosity/ low permeability sands

Bone Spring and Wolfcamp Reservoir Characteristics

- Composed of large-scale cycles of alternating carbonate and siliclastic-dominated successions
- Siliclastic members are low stand turbidite channel, fans & distal sheets
 - > Very fine-grained sandstones and silts, mudstones, and shales
 - > Porosity 4-9% Permeability 400-800nD
 - > Authigenic clays are present
- Carbonate members are high stand submarine debris flows & sheets and act as internal barriers to flow between the different sandstone members

Immediate barriers to flow outside of Bone Spring/ Wolfcamp

- Low permeability & porosity limes and siltstones at the top of the Avalon
- Low permeability & porosity siltstones and shales of the lower Wolfcamp

Surrounding Production

- Delaware Mountain Group
 - > Brushy Canyon oil production: Deepest production ~8,300' TVD
- Wolfcamp
 - > Oil production: Shallowest production ~12,100' TVD

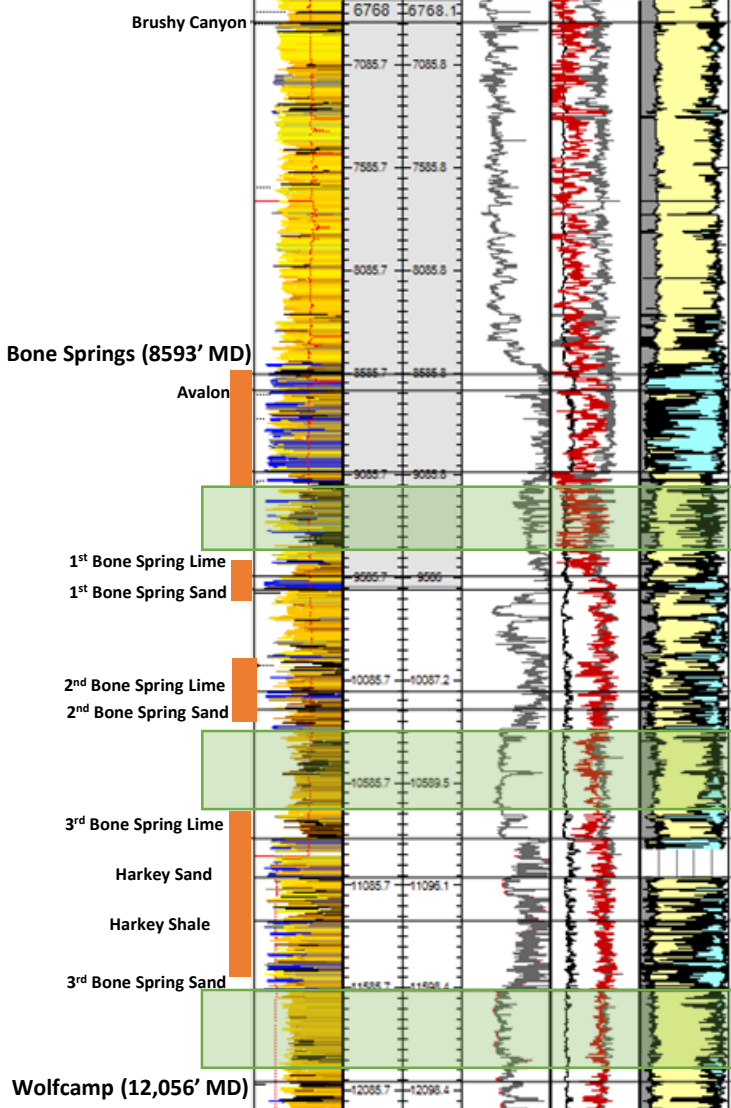

Lowest water near base of Rustler

Higher Oil Zone
Brushy Canyon
~8,300' TVD

Lower Oil Zone
Wolfcamp
~12,100' TVD

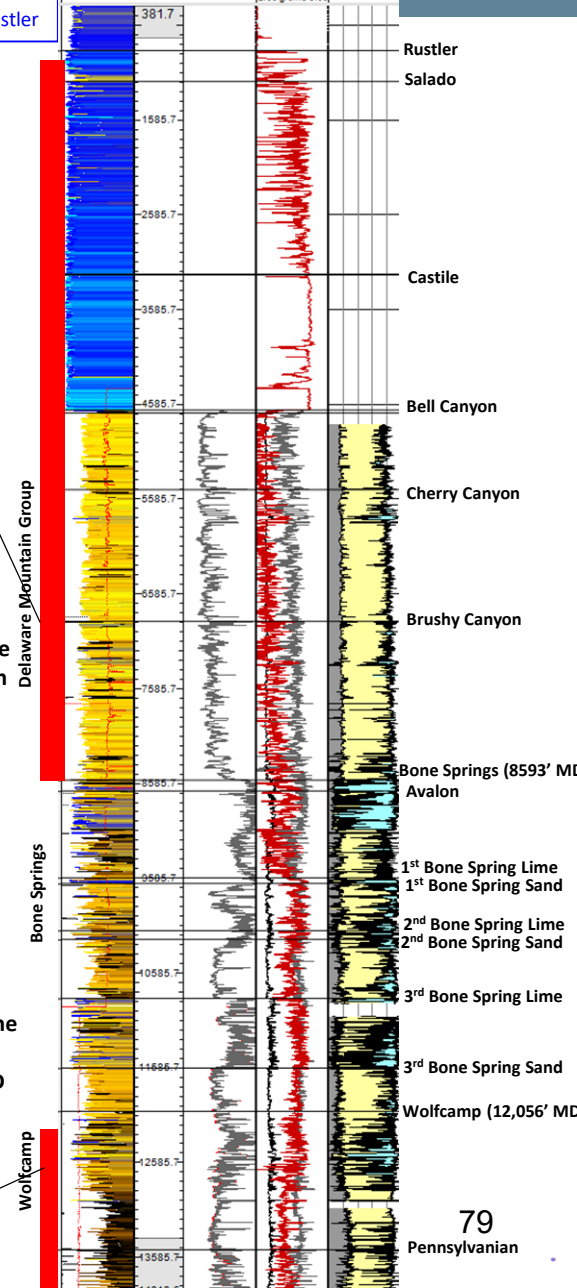

█ Barriers to migration from gas injected into the Bone Spring or Wolfcamp
█ Internal barriers to migration
█ Proposed Storage Formations

Mesa Verde Cross-section

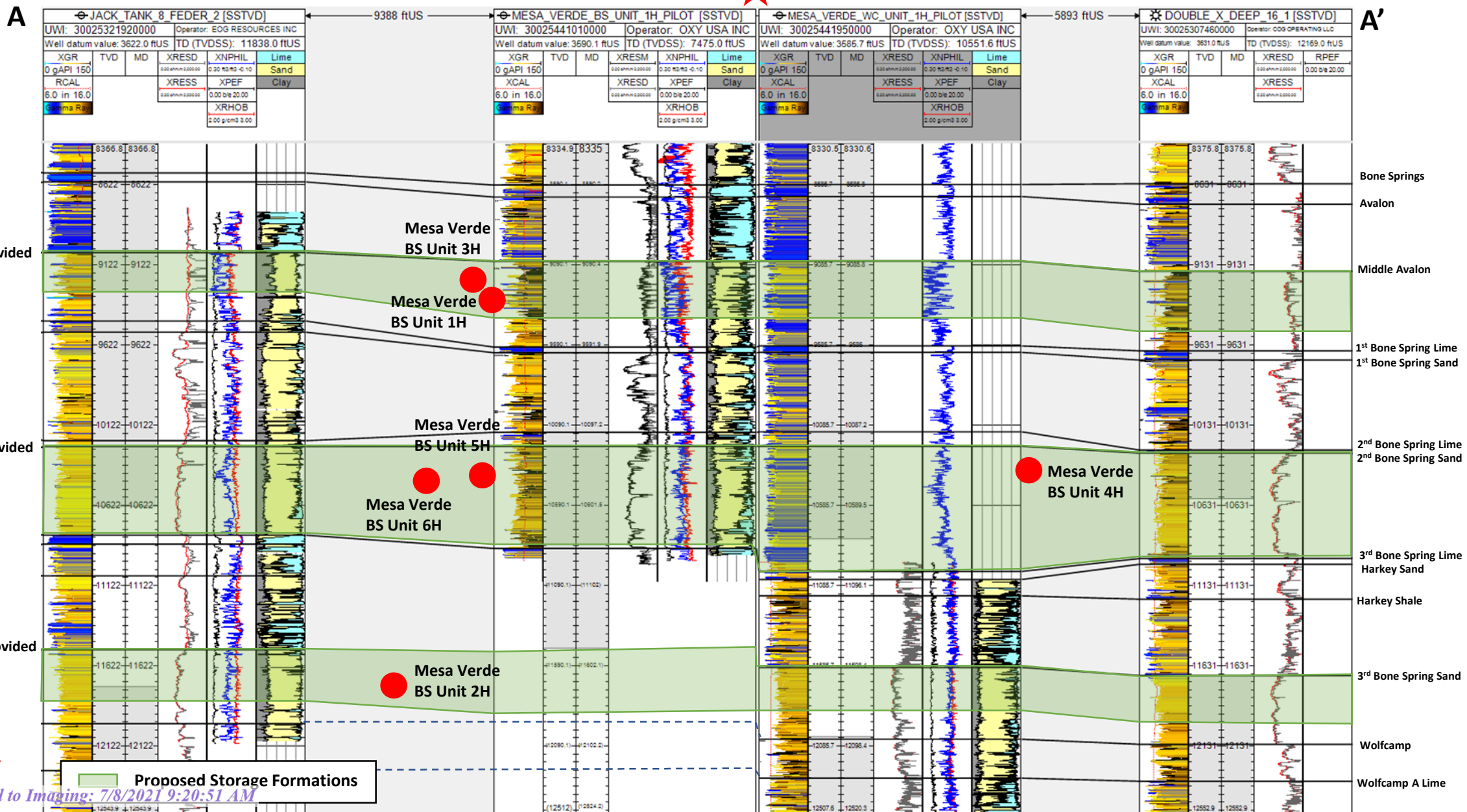

Mesa Verde Maps- Avalon

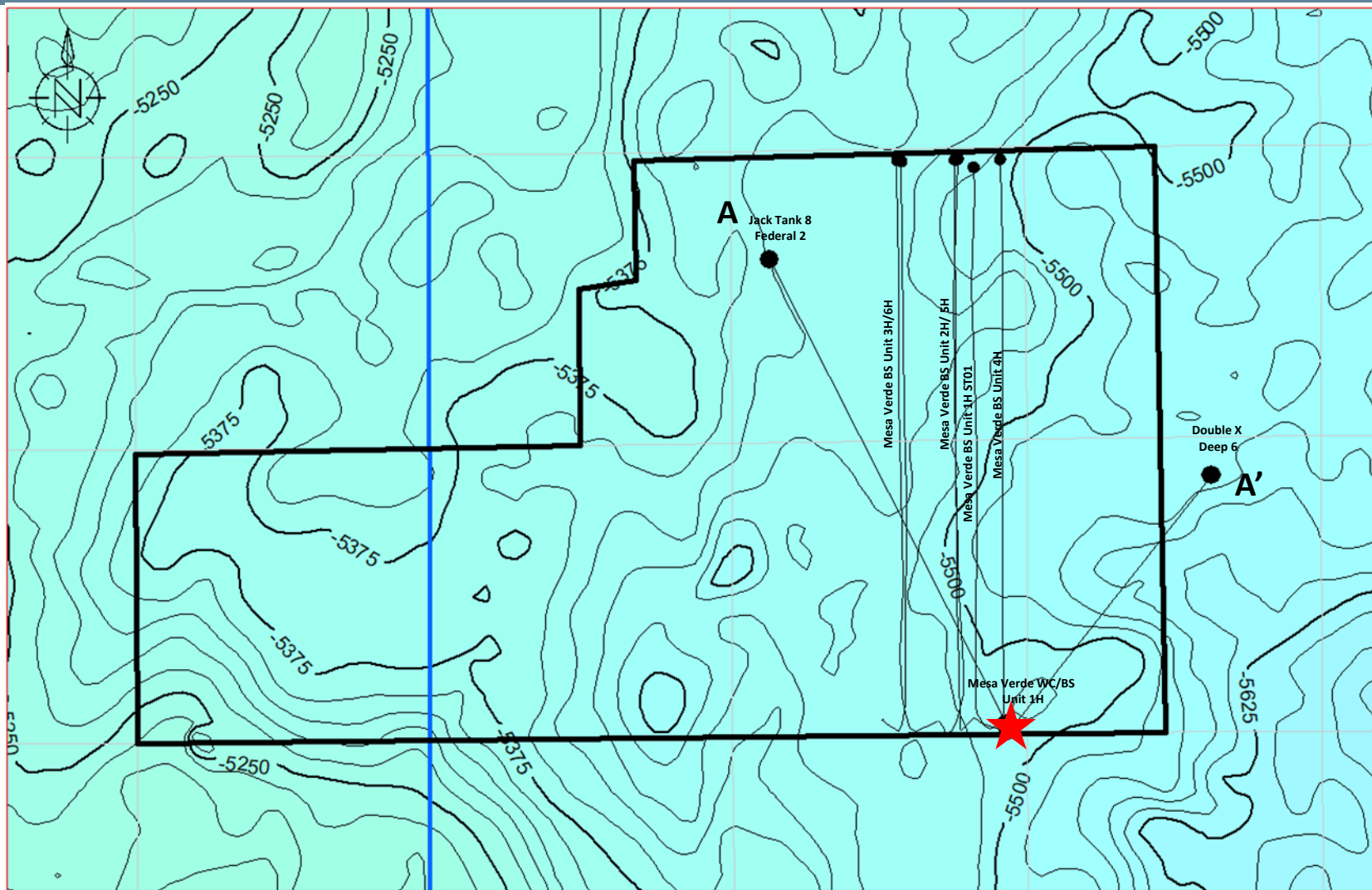

Middle Avalon Structure Map

Scale 1:31627	User name wiechmam
Date 05/10/2021	

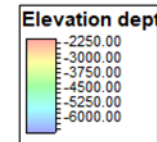
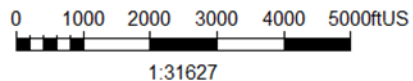

Geologic Information for Wells injecting into the Avalon member of the Bone Spring Formation

Two wells will be injecting into the lower portion of the Avalon member of the Bone Spring Formation. The wells have an average TVD of approximately 9,400 ft. (actual depth varies across the field) with lateral lengths of approximately 10,000ft. The Avalon is a very fine-grained quartz-rich and brittle siltstone with alternating cycles of carbonate rich mudstones deposited by gravity flows. Core data and petrophysical analysis indicates a tight reservoir with an average porosity of 8.4% and an average permeability of 0.000340mD. The reservoir has a clay content of 20–26% including illite and smectite. Cements include Fe-calcite, Fe-dolomite, with some quartz overgrowths. Minor amounts of pyrite (<1%) are present.

Low-permeability barriers within the upper Avalon and the 1st Bone Spring Lime act as barriers directly above and below the reservoir. The upper Avalon consist of fine-grained siltstones, carbonate mudstone and dolomudstone that have very low vertical permeabilities and an average thickness of 450 ft. Underlying is the 1st Bone Spring Lime, a ~ 200ft thick carbonate rich interval that acts as a flow barrier. Laterally the injection will be primarily contained by the reservoir volume that has been previously and partially depleted by the adjacent producing wells. The tight low-permeability reservoir and the production from the adjacent wells will be the primary constraints on the conformance of the injection to the project area and are expected to contain the injected gas.

The top of the Bone Spring Formation is at approximately 8,400 ft. TVD, with over 500 ft. of interbedded carbonate mudstones and shales acting as permeability barriers to upward migration of injected gas. Overlying the Bone Springs is the Delaware Mountain Group, which consists of connate-water bearing and hydrocarbon-bearing low permeability and porosity sands, with minor limestone and shale intervals and is approximately 3,700 ft. thick. Above that is the Castile Formation consisting of very low permeability anhydrite, gypsum, and calcite that acts as another 1,500 ft. thick barrier to upward movement of fluids. The Salado overlies the Castile and forms a 1,000 ft. thick barrier of salt. The top of the Salado is at 1,050 ft. TVD (depending on location within the field) and the deep aquifers found just above the Salado at the base of the Rustler are saline water. The top of Rustler Formation is at approximately 730 ft. The Rustler top is a continuous anhydrite layer that acts as another permeability barrier creating a perched aquifer above it that is the lowest level where fresh water is known in the area, water wells drilled in the area typically have not reached this depth. Due to the thickness of multiple impermeable rock layers above the injection reservoir there is little possibility for migration upward into freshwater aquifers where they exist.

Locate freshwater wells within two miles:

An investigation of existing shallow water wells has not found any freshwater wells within a two mile radius of this injector.

Well List:

- Mesa Verde BS Unit 3H
- Mesa Verde BS Unit 1H

I hereby certify that the information presented above is true and correct to the best of my knowledge and belief.

Michele Wiechman

Michele Wiechman, P.G
Geologist

6/11/2021

Date

Geologic Information for Wells injecting into the 3rd Bone Spring Sand Member, Bone Spring Formation

One well will be injecting into the 3rd Bone Sandstone of the Bone Spring Formation. The well has an TVD of approximately 11,800 ft. with lateral length of 10,000 ft. The well injects into a reservoir composed of amalgamated sands with high contents of silty shales. Core and petrophysical analysis indicate a tight reservoir with average porosities of 7.5% and permeabilities of 0.003mD. The reservoir has a clay content of 10-20% including illite and smectite. Cements include Fe-calcite, Fe-dolomite, with some quartz overgrowths. Minor amounts of pyrite ($\leq 1\%$) are present.

Low-permeability siltstones, carbonate mudstones, and dolomudstone barriers of the 3rd Bone Spring Lime and the deeper Wolfcamp shales act as flow barriers above and below the reservoir. Laterally the injection will be primarily contained by the reservoir volume that has been previously and partially depleted by the adjacent producing wells. The tight low-permeability reservoir and the production from the adjacent wells will be the primary constraints on the conformance of the injection to the project area and are expected to contain the low pressure injected gas.

The top of the Bone Spring Formation is at approximately 8,400 ft. TVD, with over 2,000 ft. of interbedded carbonate mudstones and shales acting as permeability barriers to upward migration of injected gas. Overlying the Bone Springs is the Delaware Mountain Group, which consists of connate-water bearing and hydrocarbon-bearing low permeability and porosity sands, with minor limestone and shale intervals and is approximately 3,700 ft. thick. Above that is the Castile Formation consisting of very low permeability anhydrite, gypsum, and calcite that acts as another 1,500 ft. thick barrier to upward movement of fluids. The Salado overlies the Castile and forms a 1,000 ft. thick barrier of salt. The top of the Salado is at 1,050 ft. TVD (depending on location within the field) and the deep aquifers found just above the Salado at the base of the Rustler are saline water. The top of Rustler Formation is at approximately 730 ft. The Rustler top is a continuous anhydrite layer that acts as another permeability barrier creating a perched aquifer above it that is the lowest level where fresh water is known in the area, water wells drilled in the area typically have not reached this depth. Due to the thickness of multiple impermeable rock layers above the injection reservoir there is little possibility for migration upward into freshwater aquifers where they exist.

Locate freshwater wells within two miles:

An investigation of existing shallow water wells has not found any freshwater wells within a two-mile radius of this injector.

Well List:

Mesa Verde BS Unit 2H

I hereby certify that the information presented above is true and correct to the best of my knowledge and belief.

Michele Wiechman

Michele Wiechman, P.G
Geologist

6/15/2021

Date

Geologic Information for Wells injecting into the 2nd Bone Spring Sand Member of the Bone Spring Formation

Three wells will be injecting into the 2nd Bone Spring Sandstone of the Bone Spring Formation. The wells have an average TVD of approximately 10,400 ft. with lateral lengths of approximately 10,000 ft. The wells inject into a reservoir composed of tight siltstone, laminated mudstone, and pelagic shales. Core data and petrophysical analysis indicates a tight reservoir with a 7% average porosity and an average permeability of 0.0016mD. The reservoir has a clay content of 20–26% including illite and smectite. Cements include Fe-calcite, Fe-dolomite, with some quartz overgrowths. Minor amounts of pyrite (<1%) are present.

Low-permeability carbonate mudstones and dolomudstone barriers of the 2nd Bone Spring Lime and 3rd Bone Spring Lime act as flow barriers directly above and below the reservoir. Laterally the injection will be primarily contained by the reservoir volume that has been previously and partially depleted by the adjacent producing wells. The tight low-permeability reservoir and the production from the adjacent wells will be the primary constraints on the conformance of the injection to the project area and are expected to contain the low pressure injected gas.

The top of the Bone Spring Formation is at approximately 8,400 ft. TVD, with over 2,000 ft. of interbedded carbonate mudstones and shales acting as permeability barriers to upward migration of injected gas. Overlying the Bone Springs is the Delaware Mountain Group, which consists of connate-water bearing and hydrocarbon-bearing low permeability and porosity sands, with minor limestone and shale intervals and is approximately 3,700 ft. thick. Above that is the Castile Formation consisting of very low permeability anhydrite, gypsum, and calcite that acts as another 1,500 ft. thick barrier to upward movement of fluids. The Salado overlies the Castile and forms a 1,000 ft. thick barrier of salt. The top of the Salado is at 1,050 ft. TVD (depending on location within the field) and the deep aquifers found just above the Salado at the base of the Rustler are saline water. The top of Rustler Formation is at approximately 730 ft. The Rustler top is a continuous anhydrite layer that acts as another permeability barrier creating a perched aquifer above it that is the lowest level where fresh water is known in the area, water wells drilled in the area typically have not reached this depth. Due to the thickness of multiple impermeable rock layers above the injection reservoir there is little possibility for migration upward into freshwater aquifers where they exist.

Locate freshwater wells within two miles:

An investigation of existing shallow water wells has not found any freshwater wells within a two-mile radius of this injector.

Well List:

- Mesa Verde BS Unit 4H
- Mesa Verde BS Unit 5H
- Mesa Verde BS Unit 6H

I hereby certify that the information presented above is true and correct to the best of my knowledge and belief.



Michele Wiechman, P.G
Geologist



Date

Closed Loop Gas Capture (CLGC) Project

Affirmative Statement 1

The operator examined the available geologic and engineering data and found no evidence of open faults or other hydrologic connections between the disposal zone and any underground source of drinking water.

Michele Wiechman
Michele Wiechman, Geologist

6/10/2021
Date

Xueying Xie
Xueying Xie, Reservoir Engineer

6/10/2021
Date

Reservoir Engineering

Project Overview - MV

- Closed loop gas capture project (CLGC) IN Oxy's NM assets
- Produced gas injection into productive formations in NM (Avalon, 2nd Bone Spring Sand, 3rd Bone Spring Sand)
- Gas injection into horizontal wells of 10,000 ft lateral length
- Purpose of Modeling
 - > Review potential effects on wells adjacent to the CLGC area
 - > Quantify movement of the injected gas
 - > Utilize data from Cedar Canyon Huff and Puff Projects

Model Set up

- Uses Cedar Canyon Sec 16 2nd BSS (as shown in layout below)
- Gas Injection pilot (EOR) was implemented in CC16-7H well in 2017
- Reservoir model is history matched for primary production and gas injection pilot
- Model is also tuned to capture injection gas breakthrough in offset wells that was observed during pilot period
- Gas injection pilot wells are 4 wells per section; model is adjusted to simulate the effect of closer wells (6 wps)

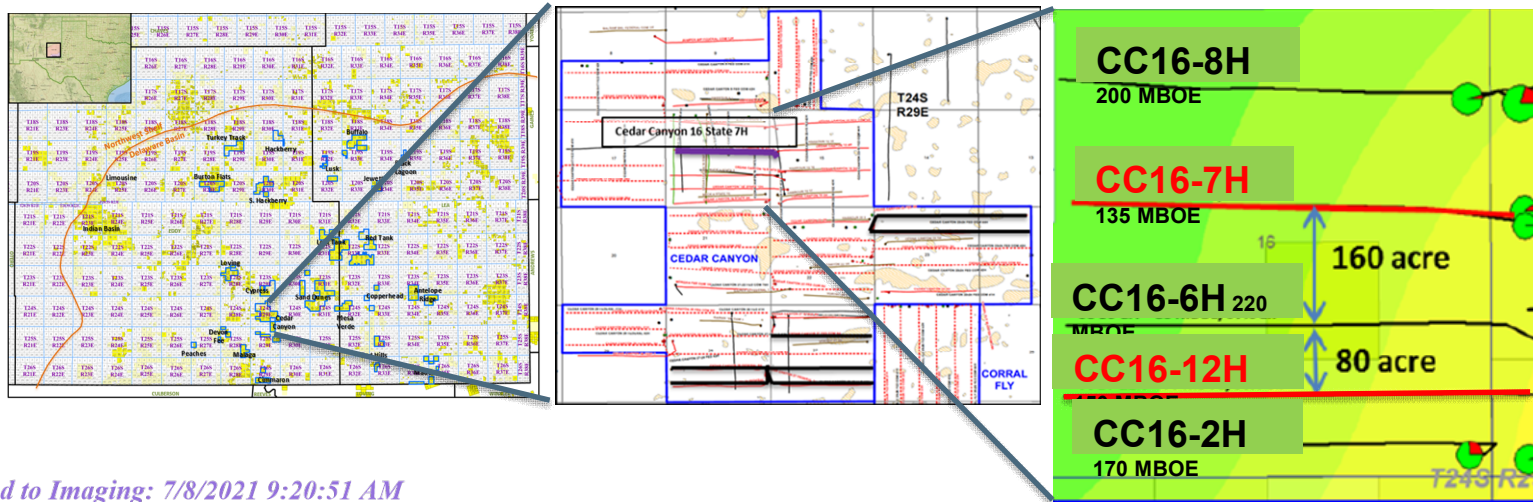

Cedar Canyon Section-16 Reservoir Model

Location: Lea County, NM
 Model Acreage: 640
 Pay Horizon: 2nd Bone Springs Sand
 Lithology: Sandstone interbedded with Limestone
 Trap Type: Stratigraphic
 Nominal Depth: 8400 ft
 Gas Cap (at discovery): No
 Primary Drive Mechanism: Solution Gas Drive

Structure & Permeability
 1,177,400 Grids
 56 Layers

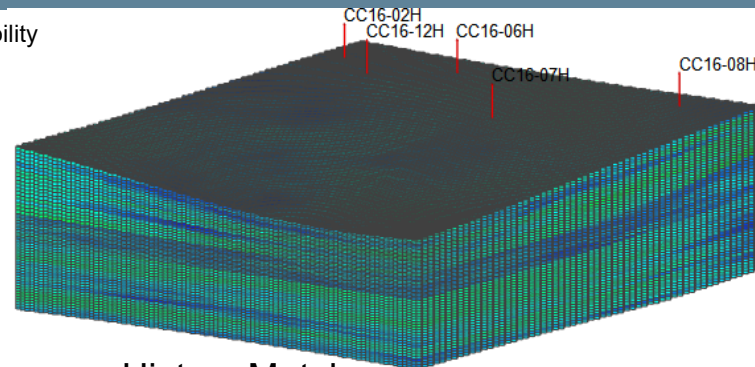

History Match

Gross Pay:	320 ft
Net Pay:	320 ft
Avg Porosity:	6.8%
Initial Sw:	50%
Permeability:	0.001md (matrix)
Initial Reservoir Pressure:	4500 psi
Reservoir Temperature:	150 F
Oil Gravity:	42 API
Boi:	1.63 RB/STB
Rsi:	1480 SCF/STB
Original Oil in Place:	28 MMSTB

Model Inputs

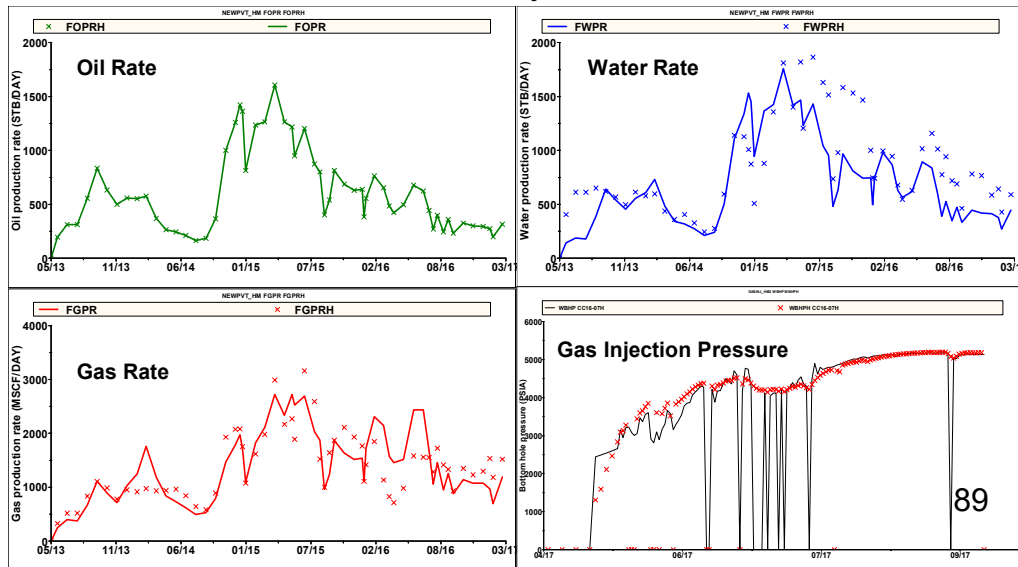

Gas Storage Simulation Process

- Run primary production for all wells for additional period (post history match) – Base Case
- Inject gas in injection well at 2MMSCFPD for 7 days
- Produce the injection well post injection – Injection Case
- Observe the effect on oil, gas rate/recovery in injection well and offset wells by comparing Base and Injection cases

Gas Injection rates

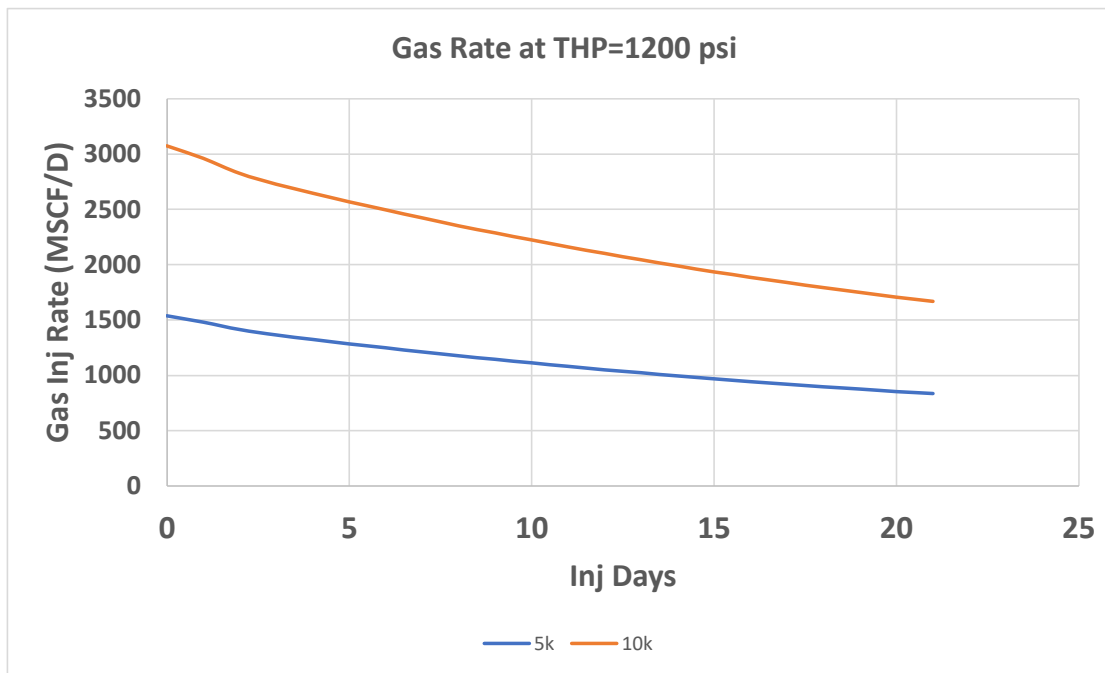

For a 10k well, 3 MMSCFPD is the max injection rate at THP of 1200 psi. Injection rate declines to about 50% of its initial value in 3 weeks. For long injection case a flat injection rate of 3MMSCFPD for 3 weeks is used as worst-case scenario.

Gas Injection Profile

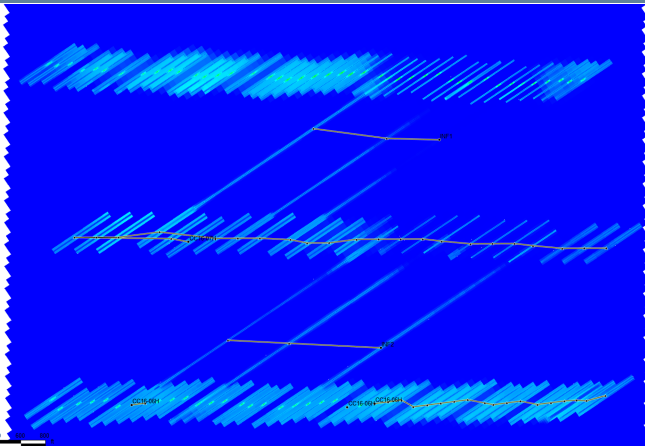

Before injection

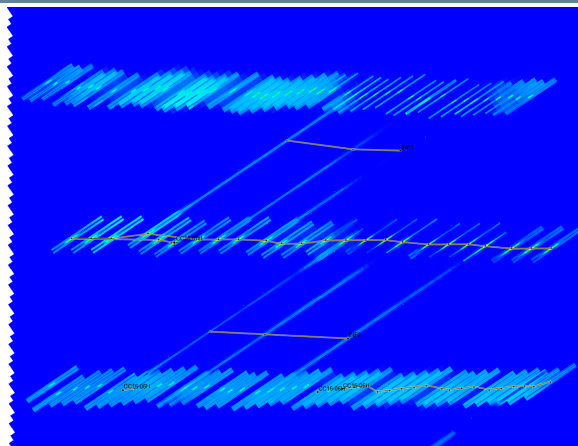

After 1 week of injection (3 MMSCFPD)

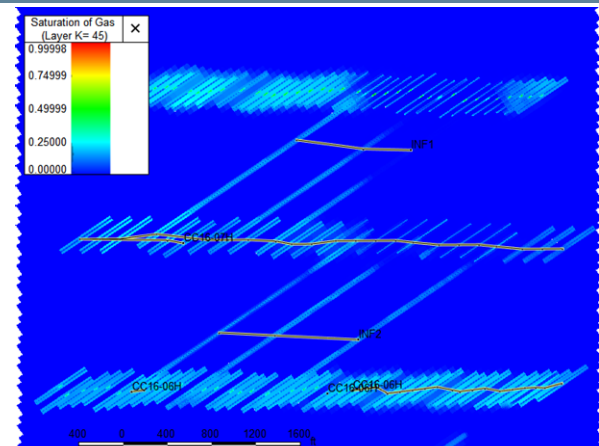

After 16 months production

Before Injection CC16-7H Blow-up

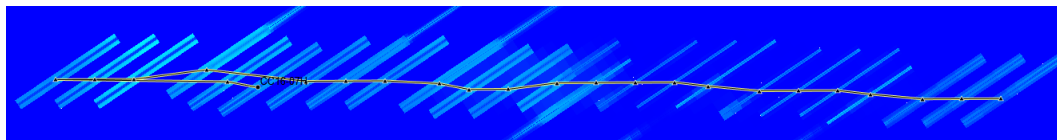

After Injection CC16-7H Blow-up

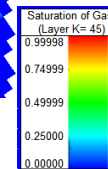
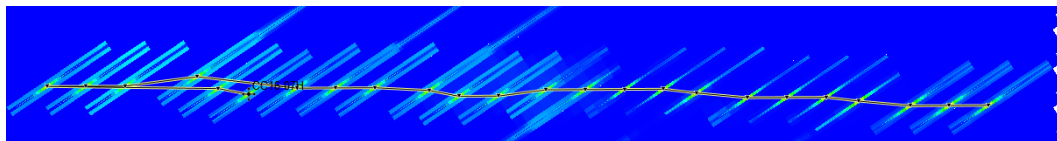

- Gas is stored within fractures.
- All injection cases indicate horizontal gas movement of 100 ft or less into the fractures.

Pressure Profile

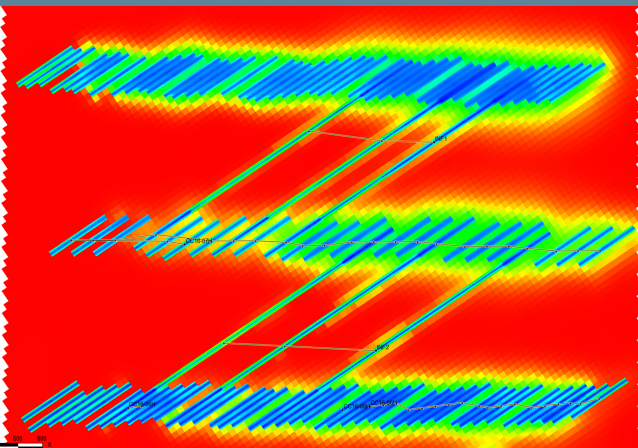

Before injection

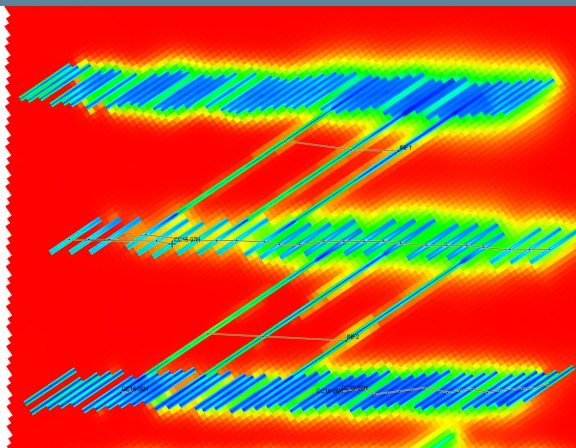

After 1 week of injection (3 MMSCFPD)

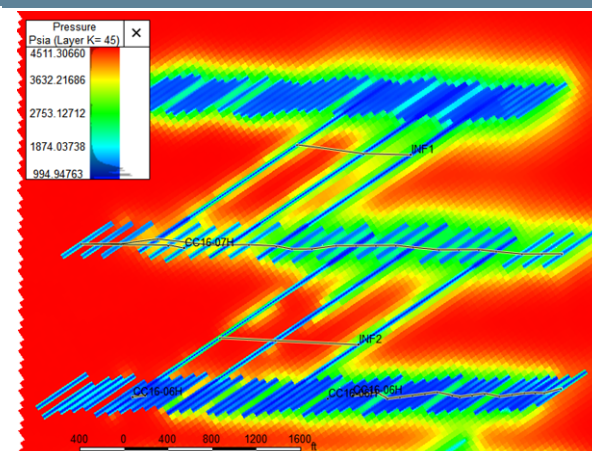

After 16 months production

Before Injection CC16-7H Blow-up

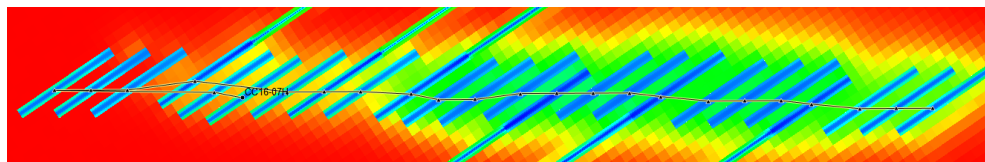

After Injection CC16-7H Blow-up

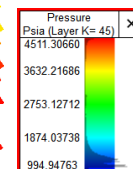
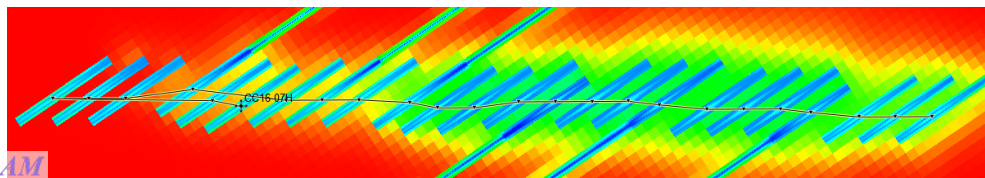

Summary of Cases

Case	Injection Description*	WPS	Oil recovery effect in injected well (MBO)	Oil recovery effect in offset wells (MBO)	Gas breakthrough in Offset well
1	Single Well	4	No change	No change	No
2	Single Well**	6	No change	No change	No
3	Single Well	8	No change	No change	No
4	Single Well (Multiple injection and production cycles)	6	No change	No change	No
5	Single well***	6	No change	No change	No
6	Multiple Adjacent Wells	4	No change	No change	No
7	Multiple Adjacent Wells	6	No change	No change	No
8	Multiple Adjacent Wells	8	No change	No change	No

*All injection at 2MMSCF/DAY for 7 days except cases 2 and 5

**Injection at 3MMSCF/DAY for 7 days

***Injection at constant surface pressure of 1200 psi for 21 days

Gas Storage Capacities - MV

API	Well Name	Gas Storage Capacity with 1200 psi WHP Injection	
		Fracture volume gas equivalent, mmscf	Total prod gas equivalent, mmscf
30025441010100	MESA VERDE BS UNIT 1H ST1	291	1799
30025441960000	MESA VERDE BS UNIT 2H	280	1326
30025441830000	MESA VERDE BS UNIT 3H	289	1463
30025440640000	MESA VERDE BS UNIT 4H	288	1818
30025441850000	MESA VERDE BS UNIT 5H	290	1682
30025440420000	MESA VERDE BS UNIT 6H	278	1633

- Gas storage capacity is high for each well
 - Even just stored gas in fractures, the capacity is over 200 mmscf
- The expected gas injection volume for each well during each event could be up to 60 mmscf, this is way below the storage capacity.

Frac Height and SRV

- **Frac height:**
 - **3BSS/XYA: Based on Calmon 171H,**
 - XH = 350'
 - Xf=400'
 - **2BSS: Based on Nimitz**
 - XH = 285',
 - Xf = 300-400'
 - **Avalon: Based on Tanks Avogato**
 - XH= 340'
 - Xf = 350'

- **SRV**
 - **SRV= 2*Xf*Xh*Well length**

API 14	Well Name	SRV, ft ³
30025441010100	MV-BS-1H-ST1	2,332,400,000
30025441960000	MV-BS-2H	2,730,280,000
30025441830000	MV-BS-3H	2,356,438,000
30025440640000	Mesa Verde BS Unit 4H	1,975,449,000
30025441850000	Mesa Verde BS Unit 5H	1,975,449,000
30025440420000	Mesa Verde BS Unit 6H	1,932,157,500

Closed Loop Gas Capture (CLGC) Project

Affirmative Statement 2

The operator examined the available geologic and engineering data and determined 1) the total recoverable volume of hydrocarbons from the reservoir will not be adversely affected by the project and 2) the gas composition will not damage the reservoir.

Xueying Xie

6/9/2021

Xueying Xie, Reservoir Engineer

Date





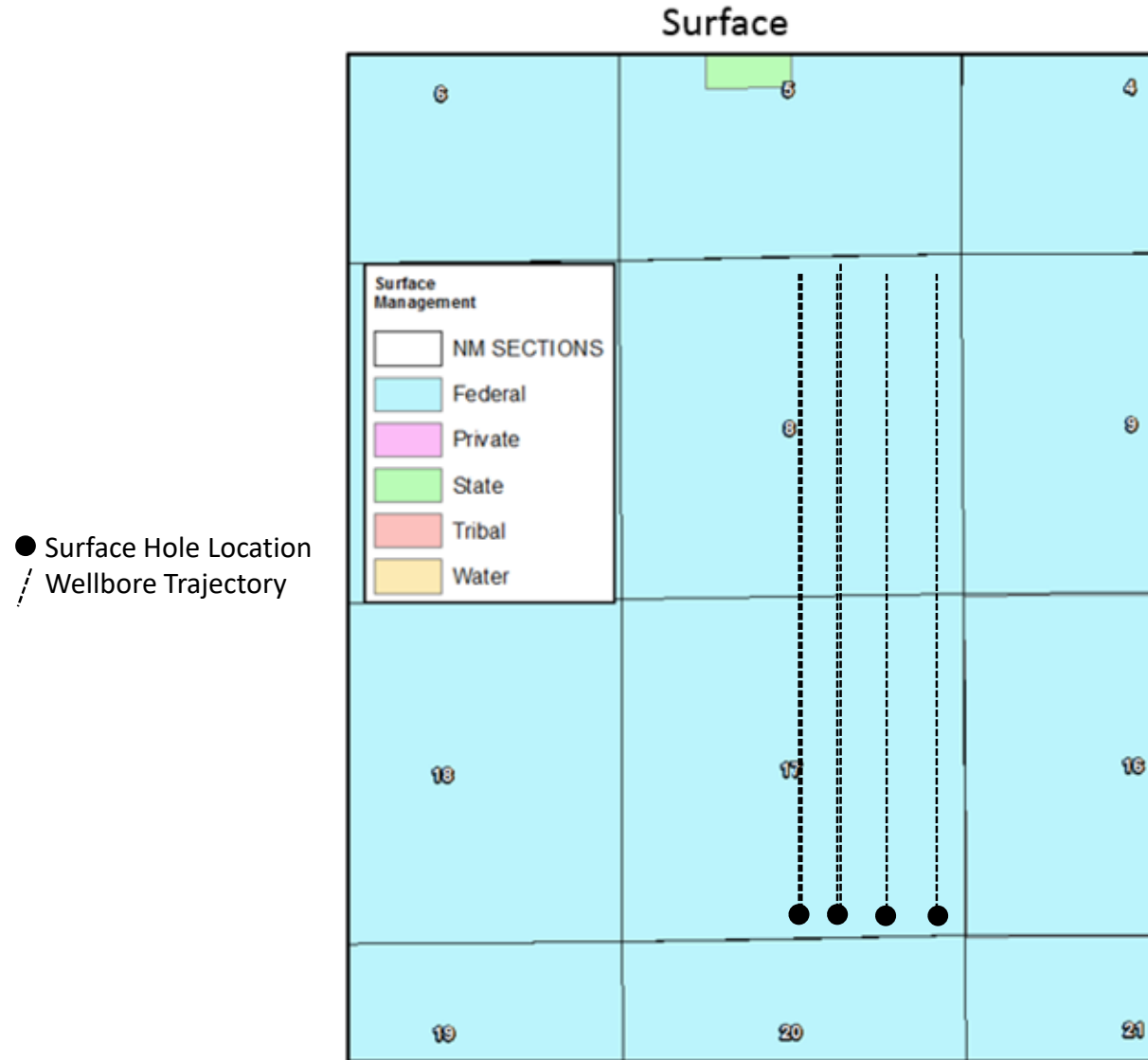

Notice

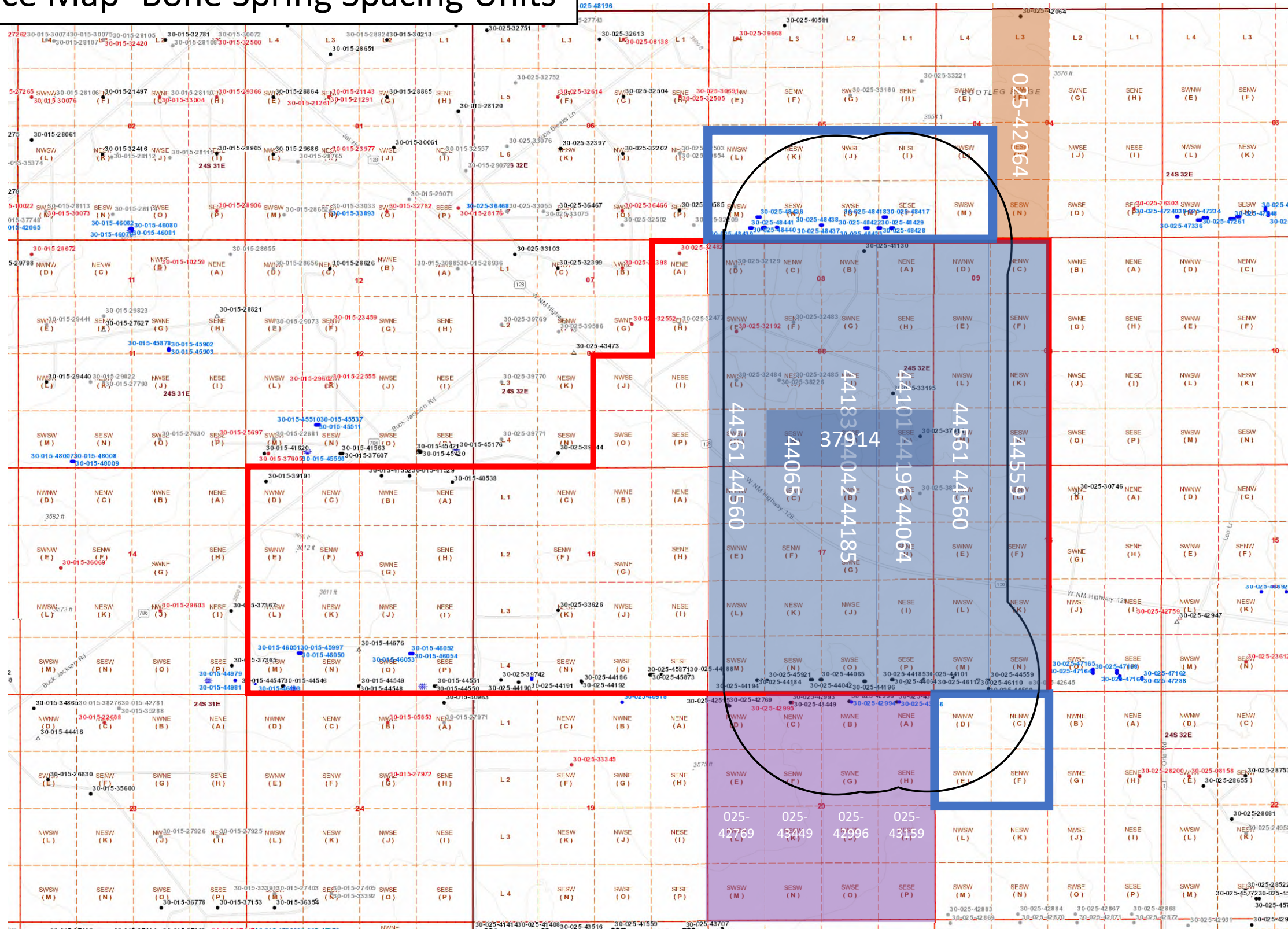
Surface Ownership Map



Notice Map- Bone Spring Spacing Units



- Key**
-  Mesa Verde Unit Outline
 -  1/2 mile AOR
 -  Oxy HSU
 -  EOG HSU
 -  Devon HSU
 -  Determined Lessee or Unleased MIO

Mesa Verde Notice List

Name	Street	City	State	Zip Code	Full Address
Surface Owner					
BLM	620 E. Greene St.	Carlsbad	NM	88220	BLM 620 E. Greene St. Carlsbad, NM 88220
Leasehold Operators					
DEVON ENERGY PRODUCTION COMPANY, LP	333 West Sheridan Avenue	Oklahoma City	OK	73102	DEVON ENERGY PRODUCTION COMPANY, LP 333 West Sheridan Avenue Oklahoma City, OK 73102
EOG Resources Inc.	P.O. Box 2267	Midland	TX	79702	EOG Resources Inc. P.O. Box 2267 Midland, TX 79702
Affected Persons					
28TwentyEight Energy LLC	5790 Saintsbury Dr	The Colony	TX	75056	28TwentyEight Energy LLC 5790 Saintsbury Dr The Colony, TX 75056
3 Knights Operating LLC	6404 County Road 1440	Lubbock	TX	79407	3 Knights Operating LLC 6404 County Road 1440 Lubbock, TX 79407
3XT Holdings LLC	5325 County Road 7560	Lubbock	TX	79424	3XT Holdings LLC 5325 County Road 7560 Lubbock, TX 79424
ABO Empire LLC	P.O. Box 900	Artesia	NM	88211	ABO Empire LLC P.O. Box 900 Artesia, NM 88211
Bettis Brothers Inc	500 W. Texas Ste #830	Midland	TX	79701	Bettis Brothers Inc 500 W. Texas Ste #830 Midland, TX 79701
Burlington Resources Oil and Gas Co LP	P.O. Box 22295	Chicago	IL	60673	Burlington Resources Oil and Gas Co LP P.O. Box 22295 Chicago, IL 60673
Chesapeake Exploration LLC	6100 N. Western	Oklahoma City	OK	73118	Chesapeake Exploration LLC 6100 N. Western Oklahoma City, OK 73118
CHEVRON USA INC	1400 Smith St.	Houston	TX	77002	CHEVRON USA INC 1400 Smith St. Houston, TX 77002
COG Operating LLC	600 W. Illinois Ave	Midland	TX	79701	COG Operating LLC 600 W. Illinois Ave Midland, TX 79701
COG PRODUCTION LLC	600 W. Illinois Ave	Midland	TX	79701	COG PRODUCTION LLC 600 W. Illinois Ave Midland, TX 79701
EOG Resources Inc.	P.O. Box 840321	Dallas	TX	75284	EOG Resources Inc. P.O. Box 840321 Dallas, TX 75284
EOG Y RESOURCES, INC.	P.O. Box 840321	Dallas	TX	75284	EOG Y RESOURCES, INC. P.O. Box 840321 Dallas, TX 75284
EP Energy E&P Company LP	P.O. Box 4660	Houston	TX	77210	EP Energy E&P Company LP P.O. Box 4660 Houston, TX 77210
Frank Pannell	P.O. Box 3721	Midland	TX	79702	Frank Pannell P.O. Box 3721 Midland, TX 79702
Hillcorp Energy	1000 Louisiana Ste #3760	Houston	TX	77002	Hillcorp Energy 1000 Louisiana Ste #3760 Houston, TX 77002
LMS Limited Liability Co	P.O. Box 621402	Littleton	CO	80162	LMS Limited Liability Co P.O. Box 621402 Littleton, CO 80162
Merit Energy Partners II LP	13727 Noel Rd. Ste 500	Dallas	TX	75240	Merit Energy Partners II LP 13727 Noel Rd. Ste 500 Dallas, TX 75240

Merit Energy Partners	13727 Noel Rd. Ste 500	Dallas	TX	75240	Merit Energy Partners 13727 Noel Rd. Ste 500 Dallas, TX 75240
Merit Energy Partners III LP	13727 Noel Rd. Ste 500	Dallas	TX	75240	Merit Energy Partners III LP 13727 Noel Rd. Ste 500 Dallas, TX 75240
Merit Energy Partners IV LP	13727 Noel Rd. Ste 500	Dallas	TX	75240	Merit Energy Partners IV LP 13727 Noel Rd. Ste 500 Dallas, TX 75240
Mersereau Enterprises LLC	132 Castillo Ave	San Antonio	TX	78210	Mersereau Enterprises LLC 132 Castillo Ave San Antonio, TX 78210
New Mexico State Land Office	P.O. Box 1148	Santa Fe	NM	87504	New Mexico State Land Office P.O. Box 1148 Santa Fe, NM 87504
NGL WATER SOLUTIONS PERMIAN, LLC	1509 W. Wall St Ste 306	Midland	TX	79701	NGL WATER SOLUTIONS PERMIAN, LLC 1509 W. Wall St Ste 306 Midland, TX 79701
Oil Conservation Division	1220 South St. Francis Dr	Santa Fe	NM	87505	Oil Conservation Division 1220 South St. Francis Dr Santa Fe, NM 87505
Panda Pipe and Equipment	P.O. Box 3721	Midland	TX	79702	Panda Pipe and Equipment P.O. Box 3721 Midland, TX 79702
PXP Producing Company LLC	717 Texas St Ste #2100	Houston	TX	77002	PXP Producing Company LLC 717 Texas St Ste #2100 Houston, TX 77002
Robert H. Forrest Jr.	609 Elora Dr.	Carlsbad	NM	88220	Robert H. Forrest Jr. 609 Elora Dr. Carlsbad, NM 88220
Sabine Oil and Gas Corporation	1415 Louisiana St Ste 1600	Houston	TX	77002	Sabine Oil and Gas Corporation 1415 Louisiana St Ste 1600 Houston, TX 77002
TEF Corp	P.O. Box 3721	Midland	TX	79702	TEF Corp P.O. Box 3721 Midland, TX 79702
Tempo Energy Inc.	P.O. Box 1034	Midland	TX	79702	Tempo Energy Inc. P.O. Box 1034 Midland, TX 79702
Thomas E. Jennings	P.O. Box 1797	Roswell	NM	88202	Thomas E. Jennings P.O. Box 1797 Roswell, NM 88202
Timothy Zeph Jennings	P.O. Box 1797	Roswell	NM	88202	Timothy Zeph Jennings P.O. Box 1797 Roswell, NM 88202
Vladin LLC	P.O. Box 4362	Houston	TX	77210	Vladin LLC P.O. Box 4362 Houston, TX 77210
Wilfred F. Garver	2800 Hanover	Dallas	TX	75225	Wilfred F. Garver 2800 Hanover Dallas, TX 75225
XTO ENERGY, INC.	6401 Holiday Hill Rd. Building #5	Midland	TX	79707	XTO ENERGY, INC. 6401 Holiday Hill Rd. Building #5 Midland, TX 79707
XTO Holdings LLC	22777 Springwoods Village Pkwy	Spring	TX	77389	XTO Holdings LLC 22777 Springwoods Village Pkwy Spring, TX 77389