

3R - 147

REPORTS

DATE:

July 1996

August 20, 1996

Mr. Bill Olson
New Mexico Oil Conservation Division
2040 South Pacheco Street
Santa Fe, New Mexico 87505

RECEIVED

AUG 20 1996

Environmental Bureau
Oil Conservation Division

RE: Production Pit Closure Submittal

Dear Mr. Olson:

Enclosed herein are data packages for work completed at El Paso Field Services (EPFS) production pit locations where shallow groundwater was encountered during closure operations. The data included within indicate that these sites merit closure per the New Mexico Oil Conservation Division's (NMOCD) Vulnerable Area Orders and EPFS's closure plan submitted to the NMOCD. In front of each data package is a site specific checklist that indicates the work completed at each location. Each checklist is followed by a short summary of the activities and results of data collected to support closure.

Sincerely,

El Paso Field Services

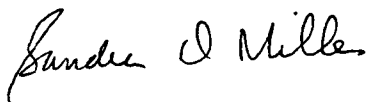

Sandra Miller
Senior Environmental Manager

j:\16297\sm

SAN JUAN BASIN PIT CLOSURES
San Juan Basin, New Mexico

Pit Closure Report

July 1996

Prepared For

El Paso Field Services
Farmington, New Mexico

Project 16297

PHILIP
ENVIRONMENTAL

OK

Closure Checklist

Meter Code 74316

Summary
Site Map
Site Assessment Sheet

Phase I Excavation YCS
closure form
soil analytical results
soil chain-of-custody
groundwater analytical results
groundwater chain-of-custody
bills of lading

Phase II Soil Boring No
boring log
soil analytical results
soil chain-of-custody
well installation form
development form
groundwater analytical
groundwater chain-of-custody

Phase III Excavation No
closure form
soil analytical results
soil chain-of-custody
groundwater analytical
groundwater chain of-custody
bills of lading

Recon performed No
groundwater analytical
soil-gas analytical

If item boxes are not checked they are not applicable



Environmental Services Group
Southern Region

Apache Federal #4
Meter Code 74316

Pit was excavated to 11 feet beneath ground surface. Headspace soil readings from excavation bottom were 3.3 parts per million. Soil analytical from composite sample was as follows; benzene - < .5 mg/kg, total BTEX - 3 mg/kg, TPH - 43.4 mg/kg. Analytical results collected from the groundwater in the bottom of the pit were as follows; benzene - <2.5 ug/L, toluene - < 2.5 ug/L, ethylbenzene - <2.5 ug/L, xylenes - <7.5 ug/l.



FIELD PIT SITE ASSESSMENT FORM

GENERAL

Meter: 74316 Location: APACHE FEDERAL #4
 Operator #: _____ Operator Name: FLOYD OIL CO. P/L District: BALLARD
 Coordinates: Letter: M Section 7 Township: 24 Range: S
 Or Latitude _____ Longitude _____
 Pit Type: Dehydrator _____ Location Drip: X Line Drip: _____ Other: _____
 Site Assessment Date: 1-24-95 Area: 07 Run: 61

SITE ASSESSMENT

NMOCD Zone: (From NMOCD Maps) Inside (1) Outside (2)

Land Type: BLM (1) State (2) Fee (3) Indian JICARILLA APACHE

Depth to Groundwater
 Less Than 50 Feet (20 points) (1)
 50 Ft to 99 Ft (10 points) (2)
 Greater Than 100 Ft (0 points) (3)

Wellhead Protection Area :
 Is it less than 1000 ft from wells, springs, or other sources of fresh water extraction? , or ; Is it less than 200 ft from a private domestic water source? (1) YES (20 points) (2) NO (0 points)

Horizontal Distance to Surface Water Body
 Less Than 200 Ft (20 points) (1)
 200 Ft to 1000 Ft (10 points) (2)
 Greater Than 1000 Ft (0 points) (3)

Name of Surface Water Body CANON LARGO
 (Surface Water Body : Perennial Rivers, Major Wash, Streams, Creeks, Irrigation Canals, Ditches, Lakes, Ponds)
 Distance to Nearest Ephemeral Stream (1) < 100' (Navajo Pits Only)
 (2) > 100'

TOTAL HAZARD RANKING SCORE: 40 POINTS

REMARKS:

Remarks : REDLINE & TOPO SHOW LOCATION INSIDE V.Z. ONLY PIT ON LOCATION. BELONGS TO EPNG. WILL CLOSE PIT.

74216

ORIGINAL PIT LOCATION

Original Pit : a) Degrees from North 113° Footage from Wellhead 118'
b) Length : 16' Width : 15' Depth : 2'

ORIGINAL PIT LOCATION

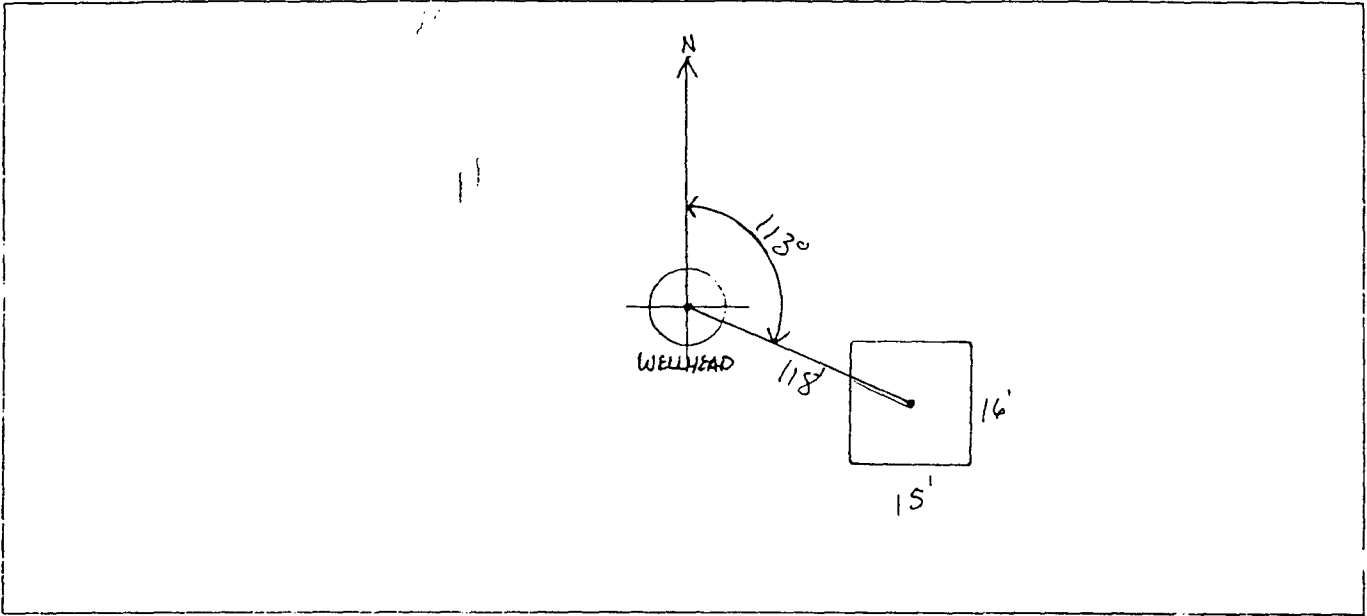

Remarks :

PHOTOS-1152

REMARKS

Completed By:

Robert Thompson

Signature

1.24.95

Date

Phase I Excavation

FIELD PIT REMEDIATION/CLOSURE FORM

GENERAL

Meter: 74316 Location: Apache Federal #4

Coordinates: Letter: M Section 7 Township: 24 Range: 5

Or Latitude _____ Longitude _____

Date Started : 9/14/95 Run: 07 61

FIELD OBSERVATIONS

Sample Number(s): JK29 JK85

Sample Depth: 11' Feet

Final PID Reading 3.3 PID Reading Depth 11' Feet

Groundwater Encountered Yes No 9/14/95
Approximate Depth 8' Feet

CLOSURE

Remediation Method :

Excavation Approx. Cubic Yards 270 9/25/95
Onsite Bioremediation DAVE FROM JICARILLA E.P.O.
Backfill Pit Without Excavation APPROVED BACKFILL 9-18-95
Phase II

Soil Disposition:

Envirotech Tierra

Other Facility Name: _____

Pit Closure Date: 9-20-95 Pit Closed By: Philip

MARKS

Remarks : Pit Pit Readings (W-1.2)(S-4.1)(E-0.8)(W-84.3)
Pit size 24x24x11 Hit ground water at 8'
Fence size 23x21x3 No Net. E.P.O. Take water sample
Less Than 100' From Ephemeral Stream

Signature of Specialist: [Signature]



**FIELD SERVICES LABORATORY
ANALYTICAL REPORT**

PIT CLOSURE PROJECT - Soil Samples Inside the GWV Zone

SAMPLE IDENTIFICATION

	Field ID	Lab ID
SAMPLE NUMBER:	JK79	947477
MTR CODE SITE NAME:	74316	Apache Federal #4
SAMPLE DATE TIME (Hrs):	09/15/95	1126
PROJECT:	Phase I - Jicarilla Pits	
DATE OF TPH EXT. ANAL.:	09/18/95	09/21/95
DATE OF BTEX EXT. ANAL.:	09/18/95	09/21/95
TYPE DESCRIPTION:	VG	Brown sand & clay

Field Remarks: (N-1.2) (S-4.1) (E-0.8) (W-84.3)

RESULTS

PARAMETER	RESULT	UNITS	QUALIFIERS			
			DF	Q	M(g)	V(ml)
BENZENE	<0.5	MG/KG				
TOLUENE	<0.5	MG/KG				
ETHYL BENZENE	<0.5	MG/KG				
TOTAL XYLENES	<1.5	MG/KG				
TOTAL BTEX	<3	MG/KG				
TPH (418.1)	43.4	MG/KG				28
HEADSPACE PID	3.3	PPM				
PERCENT SOLIDS	83.1	%				

- TPH is by EPA Method 418.1 and BTEX is by EPA Method 8020 -

The Surrogate Recovery was at 100 % for this sample All QA/QC was acceptable.
ative:

DF = Dilution Factor Used

Approved By: John Larkin

Date: 7/18/95



gicpits

CHAIN OF CUSTODY RECORD

PROJECT NUMBER	PROJECT NAME	CONTRACT LABORATORY P. O. NUMBER		REQUESTED ANALYSIS		REMARKS	
# 24324	Pit Closure Project			EPA 418.1	EPA 8020		TPH
SAMPLERS: (Signature) <i>[Signature]</i>		DATE	MATRIX	FIELD ID	TOTAL NUMBER OF CONTAINERS	SAMPLE TYPE	SEQUENCE #
947477	9/15/95	11:26	Soil	JK79	1	6	69
947478	9/15/95	13:29	Soil	JK80	1	6	70
Alache Federal #4 meter 74316 20-14 Line Drip L0069 meter 66918/75							
RELINQUISHED BY: (Signature)	DATE/TIME	RECEIVED BY: (Signature)	DATE/TIME	RELINQUISHED BY: (Signature)	DATE/TIME	RECEIVED BY: (Signature)	
<i>[Signature]</i>	3:55 9/15/95 12:00	<i>[Signature]</i>	9/18/95 10:35	<i>[Signature]</i>			
<i>[Signature]</i>		<i>[Signature]</i>		<i>[Signature]</i>			

REQUESTED TURNAROUND TIME:
 ROUTINE RUSH

CARRIER CO.

BILL NO.:

CHARGE CODE

505-599-2144

RESULTS & INVOICES TO:
FIELD SERVICES LABORATORY
EL PASO NATURAL GAS COMPANY
P. O. BOX 4990
FARMINGTON, NEW MEXICO 87499

RECEIVED OF LABORATORY BY: (Signature) *[Signature]*



**FIELD SERVICES LABORATORY
ANALYTICAL REPORT
PIT CLOSURE PROJECT - Water**

SAMPLE IDENTIFICATION

SAMPLE NUMBER:	947503
FIELD ID:	JK85
MTR CODE:	74316
SAMPLE DATE:	09/19/95
SAMPLE TYPE:	WG
SITE NAME:	Apache Federal #4
PROJECT:	Phase I - Jic Pits
DATE OF BTEX ANALYSIS:	09/22/95

FIELD COMMENTS: 2 VOA's for TPH & BTEX.

EPA Method 8020 (BTEX) RESULTS

PARAMETER	RESULT	QUALIFIER	WQCC LIMIT PPB
TDS - TOTAL DISSOLVED SOLIDS (PPM)	Not Required		None
BENZENE (PPB)	<2.5		10
TOLUENE (PPB)	<2.5		740
ETHYL BENZENE (PPB)	<2.5		750
TOTAL XYLENES (PPB)	<7.5		620
SURROGATE % RECOVERY	96%	Allowed Range 80 to 120 %	

NOTES:

Approved By:

John Stabel

7/18/96



CHAIN OF CUSTODY RECORD

PROJECT NUMBER # 24324		PROJECT NAME Pit Closure Project		CONTRACT LABORATORY P. O. NUMBER	
SAMPLERS: (Signature) <i>[Signature]</i>		DATE: 9/21/95		REMARKS	
LAB ID	DATE	TIME	MATRIX	FIELD ID	SEQUENCE #
	9/19/95	10:30	water	H85	75
TOTAL NUMBERS OF CONTAINERS		SAMPLE TYPE		REQUESTED ANALYSIS	
2		G		TPH EPA 418.1 BTX EPA 8020 LAB PID	
RECEIVED BY: (Signature) <i>[Signature]</i>		DATE/TIME 9/21/95 7:30		RECEIVED BY: (Signature)	
RELINQUISHED BY: (Signature) <i>[Signature]</i>		DATE/TIME 9/21/95 9:30		RECEIVED BY: (Signature) <i>[Signature]</i>	
REQUESTED TURNAROUND TIME: <input type="checkbox"/> ROUTINE <input type="checkbox"/> RUSH		SAMPLE RECEIPT REMARKS		RESULTS & INVOICES TO:	
CARRIER CO.		CHARGE CODE		FIELD SERVICES LABORATORY EL PASO NATURAL GAS COMPANY P. O. BOX 4990 FARMINGTON, NEW MEXICO 87499	
BILL NO.:		505-599-2144		FAX: 505-599-2261	

CONTAINS HAZARDOUS MATERIALS

STRAIGHT BILL OF LADING

ORIGINAL - NOT NEGOTIABLE

Shipper's No. _____

CARRIER: ENVIROTECH (14696-JIC) SCAC

Carrier's No. 5-20-85
Date

TO: ENVIROTECH
5796 US HIGHWAY 64
FARMINGTON, NM 87401
Street
Destination

FROM: EL PASO NATURAL GAS COMPANY
P.O. BOX 4990
Street FARMINGTON, NM 87499-4990
Origin

Zip 24324

Route: _____ Vehicle Number 4087

No. Shipping Units	HM	Kind of Packages, Description of Articles (If HAZARDOUS MATERIALS - PROPER SHIPPING NAME)	HAZARD CLASS	I.D. Number	WEIGHT (subject to correction)	RATE	LABELS REQUIRED (or exemption)
2915		Apache Fed #4 / EXEMPT SOIL	EXEMPT HYDROCARBON CONTAMINATED SOIL	10150 74316	10	YD.	N/A
2:00		Apache Fed #4 / EXEMPT SOIL	EXEMPT HYDROCARBON CONTAMINATED SOIL	74316	10	YD.	N/A
			EXEMPT HYDROCARBON CONTAMINATED SOIL			YD.	N/A
			EXEMPT HYDROCARBON CONTAMINATED SOIL			YD.	N/A
			EXEMPT HYDROCARBON CONTAMINATED SOIL			YD.	N/A

Remit C.O.D. to: _____
Address: _____
City: _____ State: _____ Zip: _____

C.O.D. FEE: Prepaid Collect
C.O.D. Amt: \$ _____

NOTE - Where the rate is dependent on value, shippers are required to state specifically in writing the agreed or declared value of the property. The agreed or declared value of the property is hereby specifically stated by the shipper to be not exceeding \$ _____ Per _____

RECEIVED - subject to the classifications and handling filed herein in effect on the date of issue of this Bill of Lading, the property described above in apparent good order, except as noted hereon and condition of contents under the contract agrees to carry to its usual place of delivery at said destination, if on its route, otherwise to deliver to another carrier on the route to said destination. It is mutually agreed as to each carrier of all or any of said property over all or any portion of said route to destination and as to each party at any time interested in all or any said property, that every service to be performed hereunder shall be subject to all the bill of lading terms and conditions on the governing classification on the date of shipment. Shipper hereby certifies that he is familiar with all the bill of lading terms and conditions in the governing classification and the said terms and conditions are hereby agreed to by the shipper and accepted for himself and his assigns.

This is to certify that the above named materials are properly classified, described, packaged, marked and labeled in accordance with the applicable regulations of the Department of Transportation. PLACARDS REQUIRED PLACARDS SUPPLIED YES NO - FURNISHED BY CARRIER DRIVER SIGNATURE: _____

SHIPPER: EL PASO NATURAL GAS COMPANY
CARRIER: ENVIROTECH
PER: [Signature] DATE: 5-20-85
EMERGENCY RESPONSE EL PASO NATURAL GAS (505) 599-2141
TELEPHONE NUMBER: (505) 326-2262 PHILIP ENVIRONMENTAL
MONITORED AT ALL TIMES THE HAZARDOUS MATERIAL IS IN TRANSPORTATION, INCLUDING STORAGE

CONTAINS HAZARDOUS MATERIALS

CONTAINS HAZARDOUS MATERIALS

CONTAINS HAZARDOUS MATERIALS

STRAIGHT BILL OF LADING

ORIGINAL - NOT NEGOTIABLE

Shipper's No. _____

Carrier's No. 9-20-95
Date

CARRIER: ENVIROTECH (14696-JIC) SCAC

TO: ENVIROTECH
5796 US HIGHWAY 64
FARMINGTON, NM 87401
Zip

FROM: EL PASO NATURAL GAS COMPANY 24324
Shipper P.O. BOX 4990
Street FARMINGTON, NM 87499-4990
Origin Zip

Route: _____ Vehicle Number 4087

No. Shipping Units	HM	Kind of Packages, Description of Articles (IF HAZARDOUS MATERIALS - PROPER SHIPPING NAME)	HAZARD CLASS	I.D. Number	WEIGHT (subject to correction)	RATE	LABELS REQUIRED (or exemption)
015		C2-23 DT / Apache Fed #4	BACKFILL	74314	10		N/A
13100		C2-23 DT / Apache Fed #4	BACKFILL	74316	10		N/A
			BACKFILL				N/A
			BACKFILL				N/A
			BACKFILL				N/A

Remit C.O.D. to: _____
Address: _____
City: _____ State: _____ Zip: _____

GOOD Amt: \$ _____

C.O.D. FEE: Prepaid Collect \$ _____

NOTE - Where the rate is dependent on value, shippers are required to state specifically in writing the agreed or declared value of the property. The agreed or declared value of the property is hereby specifically stated by the shipper to be not exceeding \$ _____

RECEIVED, subject to the classifications and liability listed herein in effect on the date of issue of this Bill of Lading, the property described above in separate good order, except as noted (contents and condition of contents under the contract agree hereto) to its usual place of delivery at said destination, if on the route, otherwise to the destination specified in the bill of lading, and as to each party at any time interested in, all or any said property, that every service to be performed hereunder shall be subject to all the bill of lading terms and conditions in the governing classification on the date of shipment. Shipper hereby certifies that he is familiar with all the bill of lading terms and conditions in the governing classification and the said terms and conditions are hereby agreed to by the shipper and accepted for himself and his assigns.

This is to certify that the above named materials are properly classified, described, packaged, marked and labeled and are in proper condition for transportation according to the applicable regulations of the Department of Transportation.

Per: Sandra Miller

PLACARDS REQUIRED

N/A

PLACARDS SUPPLIED

YES NO - FURNISHED BY CARRIER DRIVER SIGNATURE: _____

SHIPPER: EL PASO NATURAL GAS COMPANY
PER: Sandra Miller DATE: 9-20-95
CARRIER: ENVIROTECH

EMERGENCY RESPONSE: EL PASO NATURAL GAS (505) 599-2141
TELEPHONE NUMBER: (505) 328-2262 PHILIP ENVIRONMENTAL INCIDENTAL TO TRANSPORTATION (1172 804)

CONTAINS HAZARDOUS MATERIALS

CONTAINS HAZARDOUS MATERIALS

CONTAINS HAZARDOUS MATERIALS

STRAIGHT BILL OF LADING

ORIGINAL - NOT NEGOTIABLE

Shipper's No. _____

CARRIER: ENVIROTECH
(14696-JIC) SCAC

Carrier's No. _____
Date 9-20-95

TO: ENVIROTECH
5796 US HIGHWAY 64
FARMINGTON, NM 87401

FROM: EL PASO NATURAL GAS COMPANY 24324
Shipper P.O. BOX 4990
Street FARMINGTON, NM 87499-4990
Origin Zip

Route: _____ Vehicle Number L-337

No. Shipping Units	Kind of Packages - Description of Articles (IF HAZARDOUS MATERIALS - PROPER SHIPPING NAME)	HAZARD CLASS	I.D. Number	WEIGHT (subject to correction)	RATE	LABELS REQUIRED (or exemption)
28:45	Apache Fed # / Envirotech	EXEMPT HYDROCARBON CONTAMINATED SOIL	74316	10	YD.	N/A
12:10	Apache Fed # / Envirotech	EXEMPT HYDROCARBON CONTAMINATED SOIL	74316	10	YD.	N/A
23:35	22144 Dip / Envirotech	EXEMPT HYDROCARBON CONTAMINATED SOIL	5105	10	YD.	N/A
		EXEMPT HYDROCARBON CONTAMINATED SOIL	40008		YD.	N/A

Remit C.O.D. to: _____
Address: _____
City: _____ State: _____ Zip: _____

Amount: \$ **COD**

C.O.D. FEE: Prepaid Collect \$ _____

NOTE: - Where the rate is dependent on value, shippers are required to state specifically in writing the agreed or declared value of the property. The agreed or declared value of the property is hereby specifically stated by the shipper to be not exceeding \$ _____

RECEIVED: subject to the classification and liability filed tariffs in effect on the date of issue of this Bill of Lading, the property described above in apparent good order, except as noted hereon, is hereby accepted by the carrier for transportation under the terms and conditions of the bill of lading. The carrier shall not be liable for loss or damage to the property unless the loss or damage is caused by the negligence of the carrier. The carrier shall not be liable for loss or damage to the property unless the loss or damage is caused by the negligence of the carrier. The carrier shall not be liable for loss or damage to the property unless the loss or damage is caused by the negligence of the carrier.

SHIPPER: EL PASO NATURAL GAS COMPANY
PER: SANDRA MILLER
DATE: 9-20-95

CARRIER: ENVIROTECH
PER: _____
DATE: 9-20-95

EMERGENCY RESPONSE: EL PASO NATURAL GAS (505) 598-2141
TELEPHONE NUMBER: (505) 328-2262 PHILIP ENVIRONMENTAL
MONITORED AT ALL TIMES THE HAZARDOUS MATERIAL IS IN TRANSPORTATION, INCLUDING STORAGE

CONTAINS HAZARDOUS MATERIALS

CONTAINS HAZARDOUS MATERIALS

CONTAINS HAZARDOUS MATERIALS

STRAIGHT BILL OF LADING

ORIGINAL - NOT NEGOTIABLE

Shipper's No. _____

RFV

Carrier's No. 14696-JIC SCAC
Date 9-20-95

CARRIER: ENVIROTECH
TO: ENVIROTECH
Consignee: 5796 US HIGHWAY 64
Street: FARMINGTON, NM 87401
Destination: Zip

FROM: EL PASO NATURAL GAS COMPANY
Shipper: P.O. BOX 4990
Street: FARMINGTON, NM 87499-4990
Origin: Zip

Route: _____ Vehicle Number 2-37

No. Shipping Units	HM (IF HAZARDOUS MATERIALS - PROPER SHIPPING NAME)	Kind of Packages, Description of Articles	HAZARD CLASS	I.D. Number	WEIGHT (subject to correction)	RATE	LABELS REQUIRED (or exemption)
2845		C2-23 DT / Apache Fed #4	BACKFILL	74316	10	YD.	N/A
12:10		C2-23 DT / Apache Fed #4	BACKFILL	74316	10	YD.	N/A
1530		ACR3DI / 2014 Linc-Dip	BACKFILL	40008	10	YD.	N/A
			BACKFILL			YD.	N/A

Remit C.O.D. to: _____
Address: _____
City: _____ State: _____ Zip: _____

COD Amt: \$ _____

C.O.D. FEE: Prepaid Collect \$ _____

NOTE - Where the rate is dependent on value, shippers are required to state specifically in writing the agreed or declared value of the property. The agreed or declared value of the property is hereby specifically stated by the shipper to be not exceeding \$ _____

RECEIVED, subject to the classifications and lawfully filed tariffs in effect on the date of issue of this Bill of Lading, the property described above in apparent good order, except as noted hereon and condition of contents under the contract agrees to carry to its usual place of delivery at said destination, if on its route, otherwise to deliver to another carrier on the route to said destination. It is mutually agreed as to each carrier of all or any of said property over all or any portion of said route to destination and as to each party at any time interested in all or any said property, that every service to be performed hereunder shall be subject to all the bill of lading and other conditions in the governing classification and the said terms and conditions are hereby agreed to by the shipper and accepted for himself and his assigns.

This is to certify that the above named materials are properly packaged, described, packaged, marked and labeled and are in proper condition for transportation according to the applicable regulations of the Department of Transportation.

PLACARDS REQUIRED

N/A

PLACARDS SUPPLIED

YES NO - FURNISHED BY CARRIER
DRIVER SIGNATURE: _____

SHIPPER: EL PASO NATURAL GAS COMPANY
PER: SANDRA MILLER
DATE: 9-20-95
CARRIER: ENVIROTECH
EMERGENCY RESPONSE: EL PASO NATURAL GAS (505) 598-2141
TELEPHONE NUMBER: 505 378-2262 PHILIP ENVIRONMENTAL
MONITORED AT ALL TIMES THE HAZARDOUS MATERIAL IS IN TRANSPORTATION, INCLUDING STORAGE
INCIDENTAL TO TRANSPORTATION (172 604)

CONTAINS HAZARDOUS MATERIALS

CONTAINS HAZARDOUS MATERIALS

CONTAINS HAZARDOUS MATERIALS

STRAIGHT BILL OF LADING

ORIGINAL - NOT NEGOTIABLE

Shipper's No. _____

CARRIER: ENVIROTECH (14696-JIC) SCAC

Carrier's No. 9-20-95
Date

TO: ENVIROTECH
Consignee 6796 US HIGHWAY 64
Street FARMINGTON, NM 87401
Destination Zip

FROM: EL PASO NATURAL GAS COMPANY 24324
Shipper P.O. BOX 4990
Street FARMINGTON, NM 87499-4990
Origin Zip

Route: _____ Vehicle Number 1-64

No. Shipping Units	HM	Kind of Packages, Description of Articles (IF HAZARDOUS MATERIALS - PROPER SHIPPING NAME)	HAZARD CLASS	I.D. Number	WEIGHT (Subject to correction)	RATE	LABELS REQUIRED (or exemption)
09.00		Apache Fed #/ Envirotech	EXEMPT HYDROCARBON CONTAMINATED SOIL	10125	10	YD.	N/A
12.20		Apache Fed #/ Envirotech	EXEMPT HYDROCARBON CONTAMINATED SOIL	4330 4316 6105	10	YD.	N/A
1535		2014 Yellow Lip / Envirotech	EXEMPT HYDROCARBON CONTAMINATED SOIL	20008	10	YD.	N/A

Remit C.O.D. to: _____
Address: _____
City: _____ State: _____ Zip: _____

C.O.D. FEE: Prepaid Collect
C.O.D. Amt: \$ COD

NOTE - Where the rate is dependent on value, shippers are required to state specifically in writing the agreed or declared value of the property. The agreed or declared value of the property is hereby specifically stated by the shipper to be not exceeding \$ _____

RECEIVED, subject to the classifications and labeling, tied to the date of issue of this Bill of Lading, the property described above in apparent good order, except as noted (contents and condition of contents or other markings on the property) and in conformity with the applicable regulations of the Department of Transportation under the contract agrees to carry to its usual place of delivery at said destination, if on its route, otherwise to deliver to another carrier on the route to said destination, in all or any said property, that every service to be performed hereunder shall be subject to all the bill of lading terms and conditions in the governing classification on the date of shipment. Shipper hereby certifies that he is familiar with all the bill of lading terms and conditions in the governing classification and the said terms and conditions are hereby agreed to by the shipper and accepted for himself and his assigns.

This is to certify that the above named materials are properly classified, packaged, marked and labeled and are in proper condition for transportation according to the applicable regulations of the Department of Transportation.

PLACARDS REQUIRED

N/A

PLACARDS SUPPLIED

YES NO - FURNISHED BY CARRIER DRIVER SIGNATURE: _____

SHIPPER: EL PASO NATURAL GAS COMPANY
PER: SANDRA MILLER

CARRIER: ENVIROTECH

DATE: 9-20-95
EMERGENCY RESPONSE EL PASO NATURAL GAS (505) 598-2141
TELEPHONE NUMBER: (505) 329-2282 PHILIP ENVIRONMENTAL

MONITORED AT ALL TIMES FOR HAZARDOUS MATERIAL IS IN TRANSPORTATION, INCLUDING STORAGE
INCIDENTAL TO TRANSPORTATION (172 604)

EL PASO (907) 2750
CONTAINS HAZARDOUS MATERIALS

CONTAINS HAZARDOUS MATERIALS

CONTAINS HAZARDOUS MATERIALS

STRAIGHT BILL OF LADING

ORIGINAL - NOT NEGOTIABLE

Shipper's No. _____

Carrier's No. _____
Date: 9-20-95

CARRIER: ENVIROTECH (14696-JIC) SCAC

TO: ENVIROTECH
5796 US HIGHWAY 64
FARMINGTON, NM 87401
Zip

FROM: EL PASO NATURAL GAS COMPANY 2432A
Shipper P.O. BOX 4990
Street FARMINGTON, NM 87499-4990
Origin Zip

Route: _____
Vehicle Number 7-641

No. of Shipping Units	Kind of Packages, Description of Articles (If HAZARDOUS MATERIALS - PROPER SHIPPING NAME)	HAZARD CLASS	I.D. Number	WEIGHT (subject to correction)	RATE	LABELS REQUIRED (or exemption)
07.00	02-23 DT / Apache Fed #4	BACKFILL	74316	15	YD.	N/A
220	02-23 DT / Apache Fed #4	BACKFILL	74316	10	YD.	N/A
535	02-23 DT / Apache Fed #4	BACKFILL	10008	10	YD.	N/A
		BACKFILL			YD.	N/A

Remit C.O.D. to: _____
Address: _____
City: _____ State: _____ Zip: _____

C.O.D. FEE: Prepaid Collect \$ _____
FREIGHT CHARGES: PREPAID COLLECT

NOTE: Where the rate is dependent on value, shippers are required to state specifically in writing the agreed or declared value of the property. The agreed or declared value of the property is hereby specifically stated by the shipper to be not exceeding \$ _____

RECEIVED: subject to the classification and liability filed herein in effect on the date of issue of this Bill of Lading, the property described above in apparent good order, except as noted herein and conditions of contents of packages, weight, marks, measurements, and destination as indicated above, which carrier, the word carrier, under the contract agrees to carry to its usual place of delivery at said destination, it on its route, otherwise to deliver to another carrier, on the route to said destination, if it is mutually agreed as to each carrier in advance of loading terms and conditions in the governing classification on the date of shipment. Shipper hereby certifies that he is familiar with all the bill of lading terms and conditions in the governing classification and the said terms and conditions are hereby agreed to by the shipper and accepted for himself and his assigns.

This is to certify that the above-named materials are properly classified, described, packaged, marked and labeled and are in proper condition for transportation according to the applicable Regulations of the Department of Transportation. YES NO - FURNISHED BY CARRIER
DRIVER SIGNATURE: _____

SHIPPER: EL PASO NATURAL GAS COMPANY
PER: SANDRA MILLER DATE: 9-20-95

CARRIER: ENVIROTECH
PER: Sandra Miller DATE: 9-20-95

EMERGENCY RESPONSE: EL PASO NATURAL GAS (505) 588-2141
TELEPHONE NUMBER: (505) 328-2282 PHILIP ENVIRONMENTAL INCIDENTAL TO TRANSPORTATION (172 804)

MONITORED AT ALL TIMES THE HAZARDOUS MATERIAL IS IN TRANSPORTATION, INCLUDING STORAGE

CONTAINS HAZARDOUS MATERIALS

CONTAINS HAZARDOUS MATERIALS

CONTAINS HAZARDOUS MATERIALS

STRAIGHT BILL OF LADING

ORIGINAL - NOT NEGOTIABLE

Shipper's No. _____

Carrier's No. _____

Date _____

CARRIER: ENVIROTECH (14696-JIC) SCAC

TO: ENVIROTECH
 6796 US HIGHWAY 64
 FARMINGTON, NM 87401

FROM: EL PASO NATURAL GAS COMPANY 24324
 P.O. BOX 4990
 Shipper Street FARMINGTON, NM 87499-4990
 Origin

Route: _____

Destination: _____ Zip: 12 hrs.

Vehicle Number: D-5-7

No. Shipping Units	H.M.	Kind of Packages, Description of Articles (If Hazardous Materials - Proper Shipping Name)	HAZARD CLASS	I.D. Number	WEIGHT (subject to correction)	RATE	LABELS REQUIRED (or exemption)
0805		Apache Red #4 / Envirotech	EXEMPT HYDROCARBON CONTAMINATED SOIL	10:30	10	YD.	N/A
12:25		Apache Red #4 / Envirotech	EXEMPT HYDROCARBON CONTAMINATED SOIL	1:40	40	YD.	N/A
1535		Apache Red #4 / Envirotech	EXEMPT HYDROCARBON CONTAMINATED SOIL	5:05	10	YD.	N/A

Remit C.O.D. to: _____

Address: _____

City: _____ State: _____ Zip: _____

COD Amt: \$

C.O.D. FEE: Prepaid Collect \$ _____

PLACARDS REQUIRED **PLACARDS SUPPLIED**

YES NO - FURNISHED BY CARRIER

DRIVER SIGNATURE: _____

SHIPPER: EL PASO NATURAL GAS COMPANY

PER: SANDRA MILLER DATE: 9-20-95

CARRIER: ENVIROTECH

PER: Sandra Miller DATE: 9-20-95

EMERGENCY RESPONSE EL PASO NATURAL GAS (505) 509-2141

TELEPHONE NUMBER: 505-326-2282 PHILLIP ENVIRONMENTAL

MONITORED AT ALL TIMES THE HAZARDOUS MATERIAL IS IN TRANSPORTATION, INCLUDING STORAGE

INCIDENTAL TO TRANSPORTATION (172 604)

8-B.L.C. 03 (REV. 7/90)

CONTAINS HAZARDOUS MATERIALS

CONTAINS HAZARDOUS MATERIALS

CONTAINS HAZARDOUS MATERIALS

NOTE: - Where the rate is dependent on value, shippers are required to state specifically in writing the agreed or declared value of the property. The agreed or declared value of the property is hereby specifically stated by the shipper to be not exceeding \$ _____

RECEIVED: subject to the classification and lawfully filed tariffs in effect on the date of issue of this Bill of Lading, the property described above in apparent good order, except as noted (contents and condition of contents of packages, unbranded, marked, consigned, and destined as indicated above, which shall remain the sole property of the shipper, being understood throughout this contract as meaning any person or corporation in possession of the property at the time of issue of this Bill of Lading, is hereby agreed to be the carrier of all or any of, said property over all or any portion of said route to destination and as to each party at any time interested in all or any said property, that every service to be performed hereunder shall be subject to all the Bill of Lading terms and conditions in the governing classification on the date of shipment.

Shipper hereby certifies that he is familiar with all the bill of lading terms and conditions in the governing classification and the said terms and conditions are hereby agreed to by the shipper and accepted for himself and his assigns.

This is to certify that the above naming, describing, marking, packaging, marking and labeling and are in proper condition for transportation according to the applicable regulations of the Department of Transportation.

CONTAINS HAZARDOUS MATERIALS

STRAIGHT BILL OF LADING

ORIGINAL - NOT NEGOTIABLE

Shipper's No. _____

Carrier's No. 9-20-95

CPK

CARRIER: ENVIROTECH (14696-JIC) SCAC

TO: ENVIROTECH
5796 US HIGHWAY 64
FARMINGTON, NM 87401
Street
Destination Zip

FROM: EL PASO NATURAL GAS COMPANY 24324
Shipper P.O. BOX 4990
Street FARMINGTON, NM 87499-4990
Origin Zip

Route: _____ Vehicle Number D5-7

No. Shipping Units	H/M	Kind of Packages, Description of Articles (IF HAZARDOUS MATERIALS - PROPER SHIPPING NAME)	HAZARD CLASS	I.D. Number	WEIGHT (subject to correction)	RATE	LABELS REQUIRED (or exemption)
0805		C2-23 DT / Apache Fed #4	BACKFILL	74316	10	YD.	N/A
1225		C2-23 DT / Apache Fed #4	BACKFILL	74316	10	YD.	N/A
535		2C23DT / ac 14 line Dump	BACKFILL	008	10	YD.	N/A
			BACKFILL			YD.	N/A

Remit C.O.D. to: _____
Address: _____
City: _____ State: _____ Zip: _____

C.O.D. FEE: Prepaid Collect
FREIGHT CHARGES: PREPAID COLLECT
C.O.D. Amt: \$ 000

NOTE - Where the rate is dependent on value, shippers are required to state specifically in writing the agreed or declared value of the property. The agreed or declared value of the property is hereby specifically stated by the shipper to be not exceeding \$ _____

RECEIVED, subject to the classifications and lawfully filed tariffs in effect on the date of issue of this Bill of Lading, the property described above in apparent good order, except as noted hereon, and condition of contents of packages (unknown, marked, consigned, and destined as indicated above which said carrier, being understood throughout this contract as meaning any person or corporation in possession of the property under the contract agrees to carry to its usual place of delivery at said destination, if on its route, otherwise to deliver to another carrier on the route to said destination. It is mutually agreed as to each carrier of all or part of the property, and of any portion thereof, that the carrier to whom the property is consigned shall be liable to the shipper for the date of shipment to each party at any time interested in all or any said property, that every service to be performed hereunder shall be subject to all the bill of lading conditions, and that the shipper hereby certifies that he is familiar with all the bill of lading terms and conditions in the governing classification and the said terms and conditions are hereby agreed to by the shipper and accepted for himself and his assigns.

This is to certify that the above-named materials are properly classified, described, packaged, marked and labeled and are in proper condition for transportation according to the applicable regulations of the Department of Transportation.

PLACARDS REQUIRED

N/A

PLACARDS SUPPLIED

YES NO - FURNISHED BY CARRIER DRIVER SIGNATURE: _____

SHIPPER: EL PASO NATURAL GAS COMPANY
PER: SANDRA MILLER
DATE: 9-20-95

CARRIER: ENVIROTECH
PER: [Signature]
DATE: 9-20-95

CONTAINS HAZARDOUS MATERIALS

CONTAINS HAZARDOUS MATERIALS

CONTAINS HAZARDOUS MATERIALS