

ATS-11-558

OCD-ARTESIA

Form 3160-3
(April 2004)

UNITED STATES
DEPARTMENT OF THE INTERIOR
BUREAU OF LAND MANAGEMENT

FORM APPROVED
OMB No. 1004-0137
Expires March 31, 2007

APPLICATION FOR PERMIT TO DRILL OR REENTER

5a. Type of work: <input checked="" type="checkbox"/> DRILL <input type="checkbox"/> REENTER		5. Lease Serial No. NMNM-83591
1b. Type of Well: <input checked="" type="checkbox"/> Oil Well <input type="checkbox"/> Gas Well <input type="checkbox"/> Other <input type="checkbox"/> Single Zone <input type="checkbox"/> Multiple Zone		6. If Indian, Allottee or Tribe Name N/A
2. Name of Operator COG Operating LLC		7. If Unit or CA Agreement, Name and No N/A
3a. Address 550 W. Texas, Suite 1300 Midland TX 79701	3b. Phone No. (include area code) 229137 (432) 685-4384	8. Lease Name and Well No. GISSLER FEDERAL #42 302499
4. Location of Well (Report location clearly and in accordance with any State requirements*) At surface: 2310' FNL & 990' FWL, UL E At proposed prod zone		9. API Well No. 30-015-39689
14. Distance in miles and direction from nearest town or post office* 2.5 miles Northeast of Loco Hills, NM		10. Field and Pool, or Exploratory Mar Loco Hills; Glorieta Yeso 97866 KOC
15. Distance from proposed* location to nearest property or lease line, ft (Also to nearest drig unit line, if any) 990'	16. No. of acres in lease 1602	11. Sec, T R M or Blk and Survey or Area Sec 5, T17S, R30E
17. Spacing Unit dedicated to this well 40	18. Distance from proposed location* to nearest well, drilling, completed, applied for, on this lease, ft 676'	12. County or Parish Eddy
19. Proposed Depth 5900'	20. BLM/BIA Bond No on file NMB000215 & NMB000740	13. State NM
21. Elevations (Show whether DF, KDB, RT, GL, etc) 3693' GL	22. Approximate date work will start* 08/31/2011	23. Estimated duration 10 days

24. Attachments

The following, completed in accordance with the requirements of Onshore Oil and Gas Order No 1, shall be attached to this form.

- | | |
|--|---|
| 1. Well plat certified by a registered surveyor | 4. Bond to cover the operations unless covered by an existing bond on file (see Item 20 above) |
| 2. A Drilling Plan | 5. Operator certification |
| 3. A Surface Use Plan (if the location is on National Forest System Lands, the SUPO shall be filed with the appropriate Forest Service Office) | 6. Such other site specific information and/or plans as may be required by the authorized officer |

25. Signature 	Name (Printed/Typed) Kelly J. Holly	Date 07/27/2011
-------------------	--	--------------------

Title
Permitting Tech

Approved by (Signature) /s/ W. W. Ingram	Name (Printed/Typed) W. W. Ingram	Date NOV 15 2011
---	--------------------------------------	---------------------

Title
FIELD MANAGER
Office
CARLSBAD FIELD OFFICE

Application approval does not warrant or certify that the applicant holds legal or equitable title to those rights in the subject lease which would entitle the applicant to conduct operations thereon.
Conditions of approval, if any, are attached

APPROVAL FOR TWO YEARS

Title 18 USC Section 1001 and Title 43 USC Section 1212, make it a crime for any person knowingly and willfully to make to any department or agency of the United States any false, fictitious or fraudulent statements or representations as to any matter within its jurisdiction

*(Instructions on page 2)

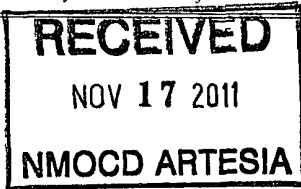

Roswell Controlled Water Basin

SEE ATTACHED FOR
CONDITIONS OF APPROVAL

Approval Subject to General Requirements
& Special Stipulations Attached

COA

MASTER DRILLING PROGRAM

1. Geologic Name of Surface Formation

Quaternary

2. Estimated Tops of Important Geologic Markers:

Quaternary	Surface
Rustler	300'
Top of Salt	500'
Base of Salt	1000'
Yates	1200'
Seven Rivers	1490'
Queen	2100'
Grayburg	2510'
San Andres	2820'
Glorietta	4250'
Paddock	4330'
Blinebry	4760'
Tubb	5750'

3. Estimated Depths of Anticipated Fresh Water, Oil and Gas

Water Sand	150'	Fresh Water
Grayburg	2510'	Oil/Gas
San Andres	2820'	Oil/Gas
Glorietta	4250'	Oil/Gas
Paddock	4330'	Oil/Gas
Blinebry	4760'	Oil/Gas
Tubb	5750'	Oil/Gas

see
COA

No other formations are expected to give up oil, gas or fresh water in measurable quantities. Setting 13 3/8" casing to ~~425'~~ and circulating cement back to the surface will protect the surface fresh water sand. The Salt Section will be protected by setting 8 5/8" casing to 1300' and circulating cement, in a single or multi-stage job and/or with an ECP, back to the surface. Any shallower zones above TD, which contain commercial quantities of oil and/or gas, will have cement circulated across them. This will be achieved by cementing, with a single or multi-stage job, the 5 1/2" production casing back 200' into the intermediate casing, (but calculated to surface) to be run at TD. If wellbore conditions arise that require immediate action and/or a change to this program, COG Operating LLC personnel will always react to protect the wellbore and/or the environment.

} See
COA

4. Casing Program

See
COA

Hole Size	Interval	OD Casing	Weight	Grade	Jt., Condition	Jt.	brst/clps/ten
17 1/2" 440	0-425'	13 3/8"	48#	H-40orJ-55	ST&C/New	ST&C	9.22/3.943/15.8
11" 1330	0-1300'	8 5/8"	24or32#	J-55	ST&C/New	ST&C	3.03/2.029/7.82
7 7/8"	0-TD	5 1/2"	15.5or17#	J-55orL-80	LT&C/New	LT&C	1.88/1.731/2.42

5. Cement Program

13 3/8" Surface Casing:

450 Class C w/ 2% Cacl2 + 0.25 pps CF, yield 1.32, back to surface. 101% excess

8 5/8" Intermediate Casing:

11" Hole:

Single Stage: LEAD: 300 sx 50:50:10 C:Poz:Gel w/ 5% Salt +0.25% CF, yield-2.45 + TAIL: 200 sx Class C w/2% CaCl2, yield-1.32, back to surface. 202% excess

Multi-Stage: Stage 1: 200 Class C w/2% CaCl2, yield - 1.32; 26% excess. Stage 2: 300 sx 50:50:10 C:Poz:Gel w/ 5% Salt +0.25% CF, yield - 2.45, back to surface, 509% excess; assumption for tool is lost circulation. Multi stage tool to be set at approximately, depending on hole conditions, 475' (50' below the surface casing). Cement volumes will be adjusted proportionately for depth changes of multi stage tool.

See
COA

5 1/2" Production Casing:

Single Stage: LEAD 500 sx 35:65:6 C:Poz:Gel w/ 5% Salt + 5 pps LCM + 0.2% SMS + 0.3% FL-52A + 0.125 pps CF, yield-2.05; + TAIL 400 sx 50:50:2 C:Poz:Gel w/ 5% Salt + 3 pps LCM + 0.6% SMS + 1% FL-25 + 1% BA-58 + 0.3% FL-52A + 0.125 pps CF, yield-1.37, 62.4% open hole excess, cement calculated back to surface.

Multi-Stage: Stage 1: (Assumed TD of 6000') 500 sx 50:50:2 C:Poz:Gel w/ 5% Salt + 3 pps LCM + 0.6% SMS + 1% FL-25 + 1% BA-58 + 0.3% FL-52A + 0.125 pps CF, yield - 1.37, 31.8% excess; Stage 2: LEAD

450 sx 50:50:2 C:Poz:Gel w/ 5% Salt + 3 pps LCM + 0.6% SMS + 1% FL-25 + 1% BA-58 + 0.3% FL-52A + 0.125 pps CF, yield - 1.37, + TAIL 250 sx Class C w/ 0.3% R-3 + 1.5% CD-32, yield - 1.02 110.8% open hole excess, cement calculated back to surface. Multi stage tool to be set at approximately, depending on hole conditions, 3000'. Cement volumes will be adjusted proportionately for depth changes of multi stage tool, assumption for tool is water flow.

6. Minimum Specifications for Pressure Control

The blowout preventer equipment (BOP) shown in Exhibit #9 will consist of a double ram-type (2000 psi WP) preventer, and in some cases possibly a 2000 psi Hydril type annular preventer as provided for in Onshore Order #2. This unit will be hydraulically operated and the ram type preventer will be equipped with blind rams on top of 4 1/2" drill pipe rams on the bottom. A 13-5/8" or 11" BOP will be used, depending on the rig selected, during the drilling of the well. The BOP will be nipped up on the 13 3/8" surface casing with BOP equipment and tested to 2000 psi. When 11" BOP is used the special drilling flange will be utilized on the 13-3/8" head to allow testing the BOP with a retrievable test plug. After setting 8-5/8" the BOP will then be nipped up on the 8 5/8" intermediate casing and tested by a third party to 2000 psi and used continuously until total depth is reached. Pipe rams will be operationally checked each 24-hour period. Blind rams will be operationally checked on each trip out of the hole. These checks will be noted on the daily tour sheets. Other accessories to the BOP equipment (Exhibit #10) will include a Kelly cock and floor safety valve, choke lines and a choke manifold (Exhibit #11) with a 2000 psi WP rating.

The majority of the rigs currently in use have a 13-5/8" BOP, so no special provision is needed for most wells in the area for conventionally testing the BOP with a test plug. However, due to the vagaries of rig scheduling, it might be that one of the few rigs with 11" BOP's might be called upon to drill any specific well in the area. Note that intermediate hole size is always 11". Therefore, COG Operating LLC respectfully requests a variance to the requirement of 13-5/8" BOP on 13-3/8" casing. When that circumstance is encountered the special flange will be utilized to allow testing the entire BOP with a test plug, without subjecting the casing to test pressure. The special flange also allows the return to full-open capability if desired.

See COA

7. Types and Characteristics of the Proposed Mud System

The well will be drilled to TD with a combination of brine, cut brine and polymer mud system. The applicable depths and properties of this system are as follows:

DEPTH	TYPE	WEIGHT	VISCOSITY	WATERLOSS
0-425' <i>440</i>	Fresh Water	8.5	28	N.C.
425-1300' <i>1330</i>	Brine	10	30	N.C.
1300'-TD	Cut Brine	8.7-9.1	29	N.C.

Sufficient mud materials will be kept at the well site to maintain mud properties and meet minimum lost circulation and weight increase requirements at all times.

8. Auxiliary Well Control and Monitoring Equipment

- A. Kelly cock will be kept in the drill string at all times.
- B. A full opening drill pipe-stabbing valve with proper drill pipe connections will be on the rig floor at all times.

9. Logging, Testing and Coring Program *See COA*

- A. The electric logging program will consist of GR-Dual Laterolog, Spectral Density, Dual Spaced Neutron, CSNG Log and will be run from TD to 8 5/8" casing shoe.
- B. Drill Stem test is not anticipated.
- C. No conventional coring is anticipated.
- D. Further testing procedures will be determined after the 5 1/2" production casing has been cemented at TD, based on drill shows and log evaluation.

10. Abnormal Conditions, Pressure, Temperatures and Potential Hazards

No abnormal pressures or temperatures are anticipated. The estimated bottom hole at TD is 110 degrees and the estimated maximum bottom hold pressure is 2300 psig. Measurable gas volumes or Hydrogen Sulfide levels have not been encountered during drilling operations in this area, although a Hydrogen Sulfide Drilling Operation Plan is attached to this program. No major loss of circulation zones has been reported in offsetting wells.

11. Anticipated Starting Date and Duration of Operations

Road and location work will not begin until approval has been received from the BLM. As this is a Master Drilling plan, please refer to the Form 3160-3 for the anticipated start date. Once commenced, drilling operations should be finished in approximately 12 days. If the well is productive, an additional 30 days will be required for completion and testing before a decision is made to install permanent facilities.

COG Operating LLC

Exhibit #9

BOPE and Choke Schematic

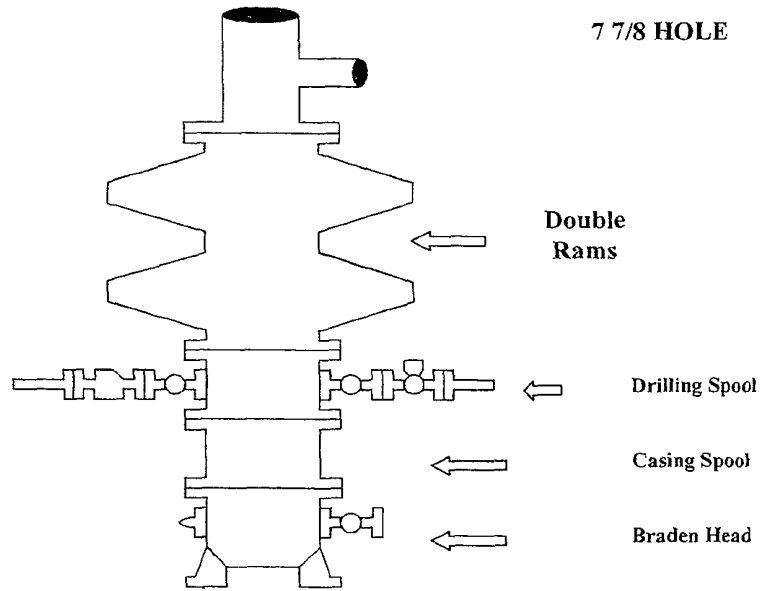

Minimum 4" Nominal choke and kill lines

Choke Manifold Requirement (2000 psi WP)
No Annular Required

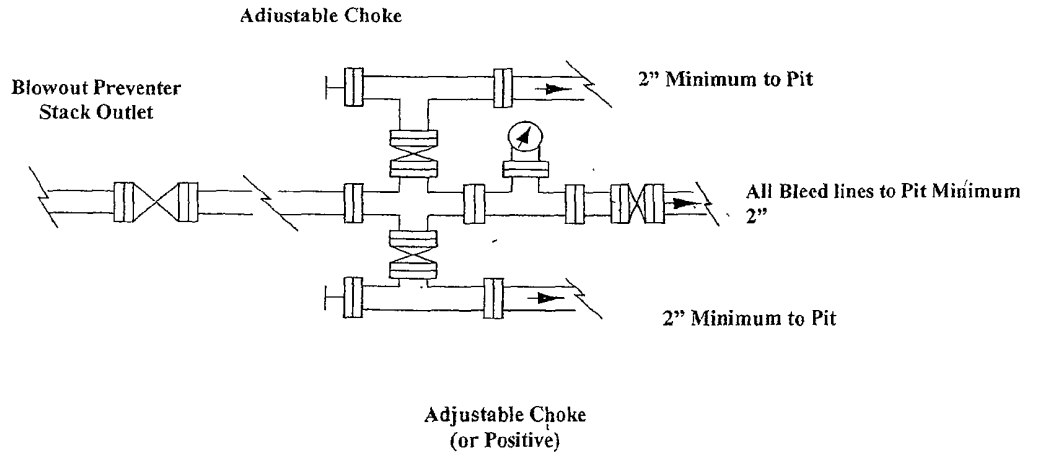

NOTES REGARDING THE BLOWOUT PREVENTERS
Master Drilling Plan
Eddy County, New Mexico

1. Drilling nipple to be so constructed that it can be removed without use of a welder through rotary table opening, with minimum I.D. equal to preventer bore.
2. Wear ring to be properly installed in head.
3. Blow out preventer and all fittings must be in good condition, 2000 psi WP minimum.
4. All fittings to be flanged.
5. Safety valve must be available on rig floor at all times with proper connections, valve to be full 2000 psi WP minimum.
6. All choke and fill lines to be securely anchored especially ends of choke lines.
7. Equipment through which bit must pass shall be at least as large as the diameter of the casing being drilled through.
8. Kelly cock on Kelly.
9. Extension wrenches and hands wheels to be properly installed.
10. Blow out preventer control to be located as close to driller's position as feasible.
11. Blow out preventer closing equipment to include minimum 40-gallon accumulator, two independent sources of pump power on each closing unit installation all API specifications.

COG Operating LLC
 Closed Loop Equipment Diagram

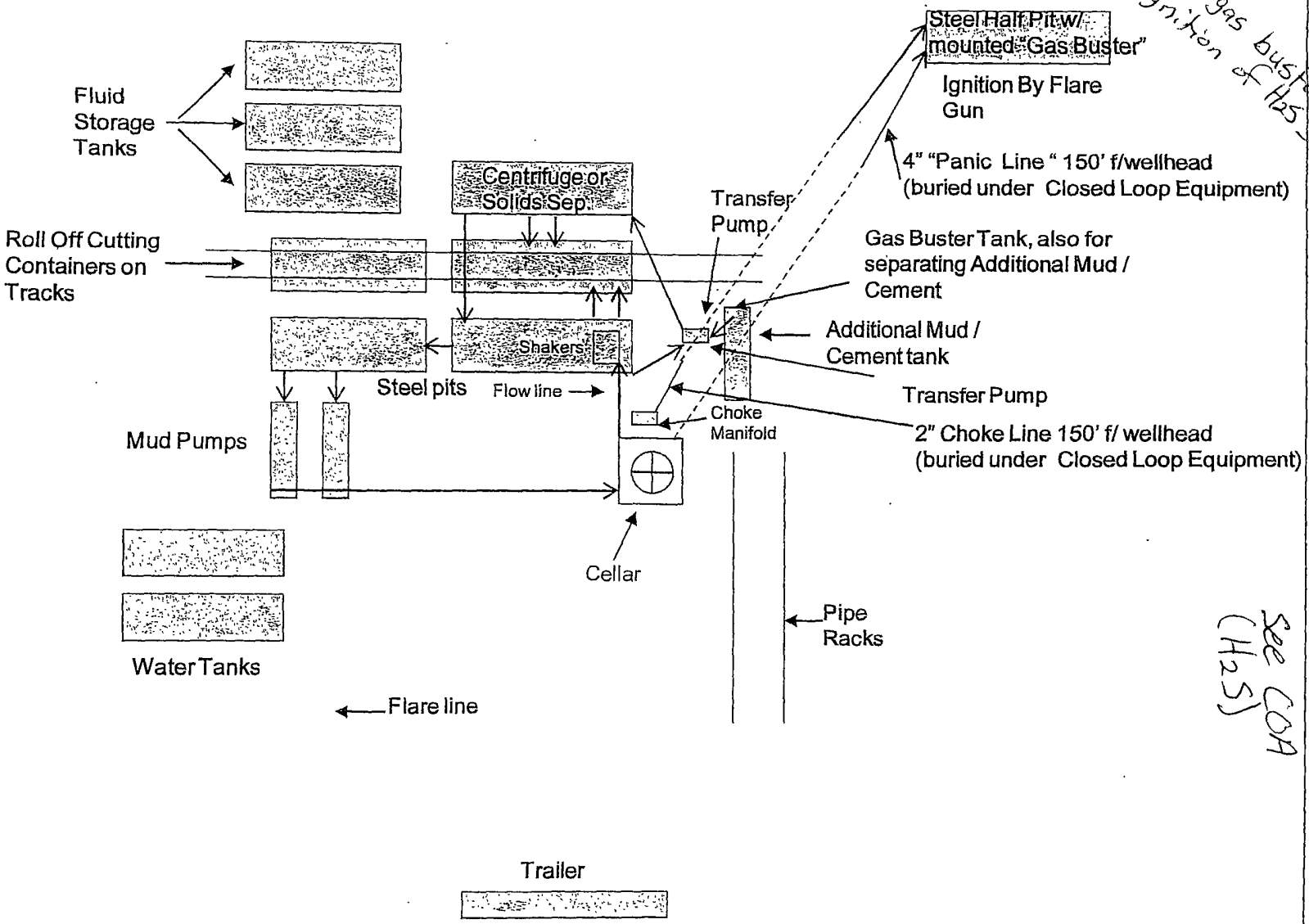

*Open bottom gas buster
 won't allow ignition of H2S gas.*

*See COA
 (H2S)*

Closed Loop Operation & Maintenance Procedure

All drilling fluid circulated over shaker(s) with cuttings discharged into roll off container.

Fluid and fines below shaker(s) are circulated with transfer pump through centrifuge(s) or solids separator with cuttings and fines discharged into roll off container.

Fluid is continuously re-circulated through equipment with polymer added to aid separation of cutting fines.

Roll off containers are lined and de-watered with fluids re-circulated into system.

Additional tank is used to capture unused drilling fluid or cement returns from casing jobs.

This equipment will be maintained 24 hrs./day by solids control personnel and or rig crews that stay on location.

Cuttings will be hauled to either:

CRI (permit number R9166)

or

GMI (permit number 711-019-001)

dependent upon which rig is available to drill this well.

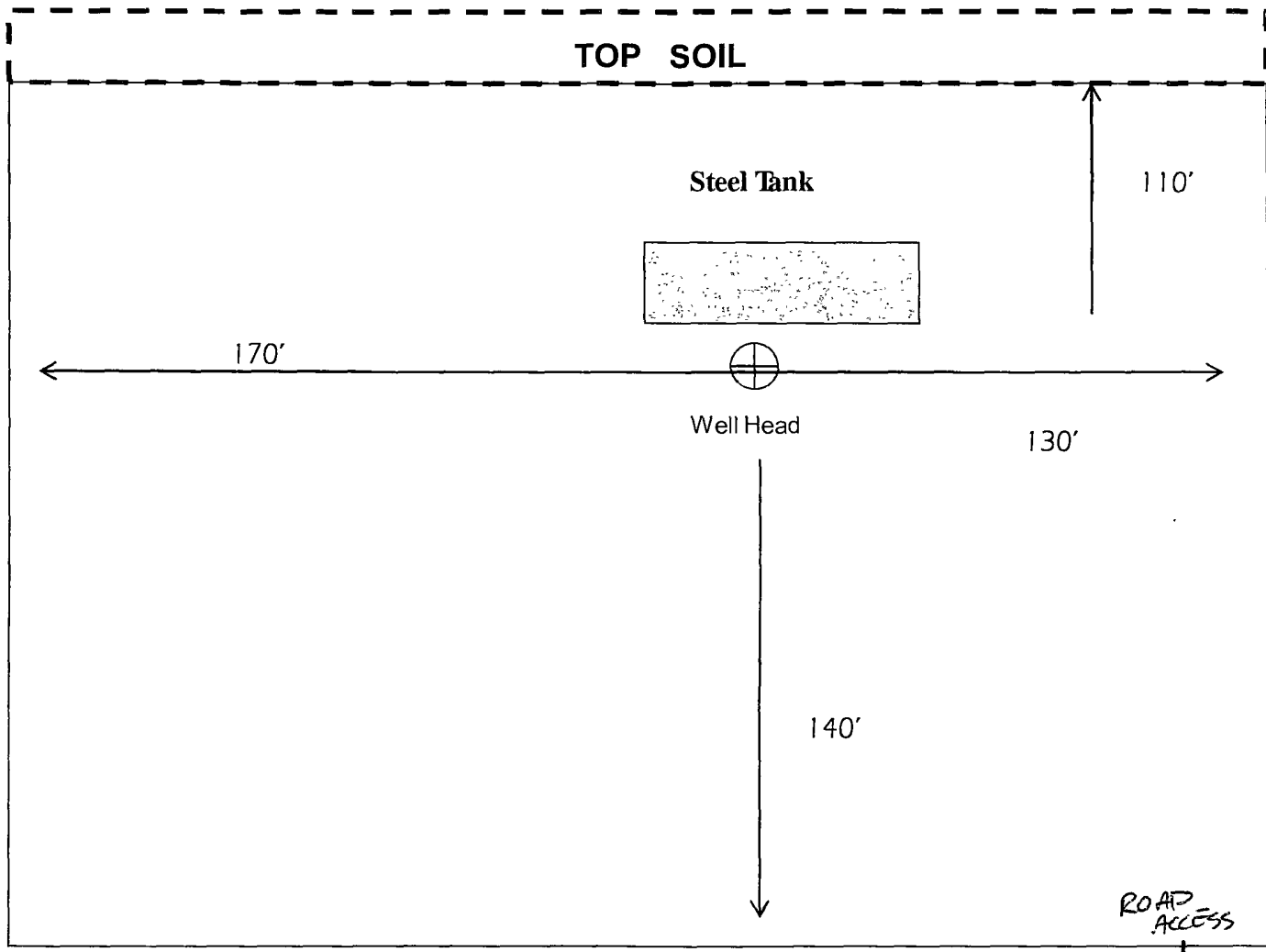

N
↓

Exhibit #6

Not To Scale

COG OPERATING LLC
Rig: Layout-Closed Loop
System: Gissler Fed #42

DISTRICT 2 CHECKLIST FOR INTENTS TO DRILL

302499

Operator COG Ope OGRID # 229134
Well Name & # GISSIE FEDERAL #42 Surface Type (F) (S) (P)
Location: UL E Sect 5, Township 17 s, RNG 30 e, Sub-surface Type (F) (S) (P)

A. Date C101 rec'd 11/15/2011 C101 reviewed 11/23/2011

- B. 1. Check mark, Information is OK on Forms:
 OGRID , BONDING , PROP CODE , WELL # , SIGNATURE
 2. Inactive Well list as of: 11/23/2011 # wells 3078 # Inactive wells 08
 a. District Grant APD but see number of inactive wells:
 No letter required ; Sent Letter to Operator , to Santa Fe
 3. Additional Bonding as of: 11/23/2011
 a. District Denial because operator needs addition bonding:
 No Letter required ; Sent Letter to Operator , To Santa Fe
 b. District Denial because of Inactive well list and Financial Assurance:
 No Letter required ; Sent Letter to Operator , To Santa Fe

C. C102 YES , NO , Signature

1. Pool La Loco Hills: GLADITA-YOSO, Code 9678 97866
 a. Dedicated acreage 40, What Units E
 b. SUR. Location Standard ; Non-Standard Location
 c. Well shares acres: Yes , No , # of wells plus this well #
 2. 2nd. Operator in same acreage, Yes , No
 Agreement Letter , Disagreement letter
 3. Intent to Directional Drill Yes , No
 a. Dedicated acreage , What Units
 b. Bottomhole Location Standard , Non-Standard Bottomhole
 4. Downhole Commingle: Yes , No
 a. Pool #2 , Code , Acres
 Pool #3 , Code , Acres
 Pool #4 , Code , Acres

5. POTASH Area Yes , No
 D. Blowout Preventer Yes , No
 E. H2S Yes , No
 F. C144 Pit Registration Yes , No

- G. Does APD require Santa Fe Approval:
 1. Non-Standard Location: Yes , No , NSL #
 2. Non-Standard Proration: Yes , No , NSP #
 3. Simultaneous Dedication: Yes , No , SD #
 Number of wells Plus #
 4. Injection order Yes , No ; PMX # or WFX #
 5. SWD order Yes , NO ; SWD #
 6. DHC from SF ; DHC-HOB ; Holding

7. OCD Approval Date 11/23/2011 API #30-015 -- 39689

8. Reviewers TS