

A-11

5. LEASE DESIGNATION AND SERIAL NO.
NMNM67980

6. IF INDIAN, ALLOTTEE OR TRIBE NAME

7. UNIT AGREEMENT NAME

8. FARM OR LEASE NAME, WELL NO.
SANTA FE FEDERAL # 9

9. API WELL NO.
30-015-~~3000~~ 32524

10. FIELD AND POOL, OR WILDCAT

11. HERRADURA BEND DELEWARE

11. SEC., T., R., OR BLK
AND SURVEY OR AREA
SEC. 35, T22S, R-28E

12. COUNTY OR PARRISH
EDDY

13. STATE
NM

dst

APPLICATION FOR PERMIT TO DRILL OR DEEPEN

1a. TYPE OF WORK **0142**
DRILL DEEPEN

b. TYPE OF WELL
OIL WELL GAS WELL OTHER

2. NAME OF OPERATOR
RAY WESTALL 18862

3. ADDRESS AND TELEPHONE NO.
P.O. BOX 4, LOCO HILLS, NEW MEXICO 88255

4. LOCATION OF WELL (REPORT LOCATION CLEARLY AND IN ACCORDANCE WITH ANY STATE REQUIREMENTS)
AT SURFACE **2310' FNL & 640' FEL**
UNIT H **ut H**

14. DISTANCE IN MILES AND DIRECTION FROM NEAREST TOWN OR POST OFFICE
12 MILES SE OF CARLSBAD

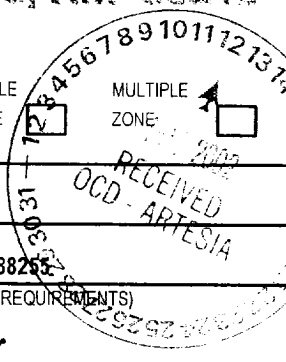

15. DISTANCE FROM PROPOSED LOCATION TO NEAREST PROPERTY OR LEASE LINE, FT. (Also to nearest drlg. unit line, if any) **840'**

16. NO. OF ACRES IN LEASE **360**

17. NO. OF ACRES ASSIGNED TO THIS WELL **40**

18. DISTANCE FROM PROPOSED LOCATION TO NEAREST WELL DRILLING, COMPLETED, OR APPLIED FOR, ON THIS LEASE, FT. **450'**

19. PROPOSED DEPTH **6400'**

20. ROTARY OR CABLE TOOLS **ROTARY**

21. ELEVATIONS (Show whether DF, RT, GR, ect.) **3049' GR**

22. APPROX. DATE WORK WILL START **ASAP**

23. PROPOSED CASING AND CEMENTING PROGRAM **Carlsbad Controlled Water Basin**

SIZE OF HOLE	GRADE, SIZE OF CASING	WT PER FT	SETTING DEPTH	QUANTITY OF CEMENT
12 1/4"	8 5/8" J-55 T&C	24	450'	400 SXS CIRC
7 7/8"	5 1/2" J-55 T&C	15.5	6400'	1500 SXS CIRC

ALL CASING WILL BE NEW, OR USED MEETING BLM SPECS.
CEMENT WILL BE CIRCULATED ON 13 3/8" AND 8 5/8" CASING.
CEMENT QUANTITIES AND ADDITIVES ARE SUBJECT TO CHANGE DUE TO HOLE CONDITIONS.

**APPROVAL SUBJECT TO
GENERAL REQUIREMENTS AND
SPECIAL STIPULATIONS
ATTACHED**

PROPOSED MUD PROGRAM

0' - 450'	FRESH WATER AND SPUD MUD
450' - TD	BRINE WATER 9.6-10#

MUD PROGRAM SUBJECT TO CHANGE DUE TO HOLE CONDITIONS

IN ABOVE SPACE DESCRIBE PROPOSED PROGRAM: If proposal is to deepen, give data on present productive zone and proposed new productive zone. If proposal is to drill or deepen directionally, give pertinent data on susurface locations and measured and true vertical depths. Give blowout preventer program, if any.

24. SIGNED *Gene Mathews* TITLE PRODUCTION SECRETARY DATE 10/04/02

(THIS SPACE FOR FEDERAL OR STATE OFFICE USE ONLY)

PERMIT NO. _____ APPROVAL DATE _____

APPLICATION APPROVAL DOES NOT WARRANT OR CERTIFY THAT THE APPLICANT HOLDS LEGAL OR EQUITABLE TITLE TO THOSE RIGHTS IN THE SUBJECT LEASE WHICH WOULD ENTITLE THE APPLICANT TO CONDUCT OPERATIONS THEREON
CONDITIONS OF APPROVAL, IF ANY:

APPROVED BY /s/ Mary J. Rugweli TITLE FIELD MANAGER DATE NOV 08 2002

TITLE 18 U.S.C. SECTION 1001, MAKES IT A CRIME FOR ANY PERSONS KNOWINGLY AND WILLFULLY TO MAKE TO ANY DEPARTMENT OR AGENCY OF THE UNITED STATES ANY FALSE, FICTICIOUS OR FRAUDULENT STATEMENTS OR REPRESENTATIONS AS TO ANY MATTER WITHIN ITS JURISDICTION

APPROVAL FOR 1 YEAR

**UNITED STATES
DEPARTMENT OF THE INTERIOR
BUREAU OF LAND MANAGEMENT**

APPLICATION FOR PERMIT TO DRILL OR DEEPEN

1a. TYPE OF WORK
 DRILL DEEPEN

b. TYPE OF WELL
 OIL WELL GAS WELL OTHER SINGLE ZONE MULTIPLE ZONE

2. NAME OF OPERATOR
RAY WESTALL

3. ADDRESS AND TELEPHONE NO.
P.O. BOX 4 LOCO HILLS, NM 88255 505.677.2370

4. LOCATION OF WELL (REPORT LOCATION CLEARLY AND IN ACCORDANCE WITH ANY STATE REQUIREMENTS)
 AT SURFACE **2237' FNL & 840' FEL**
2310 640
 AT PROPOSED PROD. ZONE **SAME**

5. LEASE DESIGNATION AND SERIAL NO.
NM 67980

6. IF INDIAN, ALLOTTEE OR TRIBE NAME

7. UNIT AGREEMENT NAME
0

8. FARM OR LEASE NAME, WELL NO.
SANTA FE FEDERAL #9

9. API WELL NO.

10. FIELD AND POOL, OR WILDCAT
E. HERRADURA BEND DELAWARE

11. SEC., T., R., M., OR BLK AND SURVEY OR AREA
SEC. 35 T-22-S R-28-E

12. COUNTY OR PARISH
EDDY

13. STATE
NEW MEXICO

14. DISTANCE IN MILES AND DIRECTION FROM NEAREST TOWN OR POST OFFICE
12 MILES SE OF CARLSBAD NM

15. DISTANCE FROM PROPOSED LOCATION TO NEAREST PROPERTY OR LEASE LINE, FT. (Also to nearest drlg. unit line, if any)	840'	16. NO. OF ACRES IN LEASE	360	17. NO. OF ACRES ASSIGNED TO THIS WELL	40
18. DISTANCE FROM PROPOSED LOCATION TO NEAREST WELL DRILLING, COMPLETED, OR APPLIED FOR, ON THIS LEASE, FT.	450	19. PROPOSED DEPTH	6400'	20. ROTARY OR CABLE TOOLS	RT

21. ELEVATIONS (Show whether DF, RT, GR, etc.)
3094 GR

APPROX. DATE WORK WILL START
01-Jan-01

23. **PROPOSED CASING AND CEMENTING PROGRAM**

SIZE OF HOLE	GRADE, SIZE OF CASING	WT PER FT	SETTING DEPTH	QUANTITY OF CEMENT
12 1/4	8 5/8" J-55 LT&C	24#	450'	400 SXS CIRCULATED
7 7/8	5 1/2" J-55 LT&C	15.5#	6400'	1500 SXS CIRCULATED

ALL CASING WILL BE NEW, OR USED MEETING BLM SPECS.

CEMENT QUANTITIES AND ADDITIVES ARE SUBJECT TO CHANGE DUE TO HOLE CONDITIONS.
 A SERIES 900 BOP WILL BE INSTALLED ON THE 8 5/8" CASING AND TESTED PRIOR TO DRILLING OUT

CARLSBAD CONTROLLED WATER BASIN

PROPOSED MUD PROGRAM

0-450'	FRESH WATER & SPUD MUD	APPROVAL SUBJECT TO GENERAL REQUIREMENTS AND SPECIAL STIPULATIONS
450-TD	BRINE WATER 9.6-10#	

MUD PROGRAM SUBJECT TO CHANGE DUE TO HOLE CONDITIONS

IN ABOVE SPACE DESCRIBE PROPOSED PROGRAM: If proposal is to deepen, give data on present productive zone and proposed new productive zone. If proposal is to drill or deepen directionally, give pertinent data on subsurface locations and measured and true vertical depths. Give blowout preventer program, if any.

24. SIGNED *[Signature]* TITLE GEOLOGIST DATE 10/10/2000

(THIS SPACE FOR FEDERAL OR STATE OFFICE USE)

PERMIT NO. _____ APPROVAL DATE _____

APPLICATION APPROVAL DOES NOT WARRANT OR CERTIFY THAT THE APPLICANT HOLDS LEGAL OR EQUITABLE TITLE TO THOSE RIGHTS IN THE SUBJECT LEASE WHICH WOULD ENTITLE THE APPLICANT TO CONDUCT OPERATIONS THEREON.
 CONDITIONS OF APPROVAL IF ANY:

APPROVED BY *[Signature]* TITLE _____ DATE _____

TITLE 18 U.S.C. SECTION 1001, MAKES IT A CRIME FOR ANY PERSONS KNOWINGLY AND WILLFULLY TO MAKE TO ANY DEPARTMENT OR AGENCY OF THE UNITED STATES ANY FALSE, FICTITIOUS OR FRAUDULENT STATEMENTS OR REPRESENTATIONS AS TO ANY MATTER WITHIN ITS JURISDICTION

RECEIVED
 OCT 16 12:12
 BUREAU OF LAND MGMT.
 CARLSBAD RESOURCE AREA

District I
 PO Box 1980, Hobbs, NM 88241-1980
 District II
 PO Drawer DD, Artesia, NM 88211-0719
 District III
 1000 Rio Brazos Rd., Aztec, NM 87410
 District IV
 PO Box 2088, Santa Fe, NM 87504-2088

State of New Mexico
 Energy, Minerals & Natural Resources Department

OIL CONSERVATION DIVISION
 PO Box 2088
 Santa Fe, NM 87504-2088

Form C-102
 Revised February 10, 1994
 Instructions on back
 Submit to Appropriate District Office
 State Lease - 4 Copies
 Fee Lease - 3 Copies

AMENDED REPORT

WELL LOCATION AND ACREAGE DEDICATION PLAT

API Number		Pool Code		Pool Name	
Property Code		Property Name			Well Number
		Santa Fe Federal			9
OGRID No.		Operator Name			Elevation
		Ray Westall Operator			3101

10 Surface Location

UL or lot no.	Section	Township	Range	Lot Idn	Feet from the	North/South line	Feet from the	East/West line	County
H	35	22s	28e		2310	North	640	East	Eddy

11 Bottom Hole Location If Different From Surface

UL or lot no.	Section	Township	Range	Lot Idn	Feet from the	North/South line	Feet from the	East/West line	County

Dedicated Acres		Joint or Infill		Consolidation Code		Order No.	

NO ALLOWABLE WILL BE ASSIGNED TO THIS COMPLETION UNTIL ALL INTERESTS HAVE BEEN CONSOLIDATED OR A NON-STANDARD UNIT HAS BEEN APPROVED BY THE DIVISION

<p>16</p>	<p>17 OPERATOR CERTIFICATION</p> <p>I hereby certify that the information contained herein is true and complete to the best of my knowledge and belief.</p> <p>Signature: <i>[Signature]</i></p> <p>Printed Name: RANDALL HARRIS</p> <p>Title: GEOLOGIST</p> <p>Date: 11/8/00</p>	
	<p>18 SURVEYOR CERTIFICATION</p> <p>I hereby certify that the well location shown on this plat was plotted from field notes of actual surveys made by me or under my supervision, and that the same is true and correct to the best of my belief.</p> <p>Date of Survey: November 27, 2000</p> <p>Signature and Seal of Professional Surveyor: P. R. PATTERSON</p> <p>8 NOV 2000</p> <p>Certificate Number: 15312</p>	
	<p>RECEIVED NOV 12 2000 DIVISION OF LAND AND MINERAL RESOURCES</p>	
	<p>NO ALLOWABLE WILL BE ASSIGNED TO THIS COMPLETION UNTIL ALL INTERESTS HAVE BEEN CONSOLIDATED OR A NON-STANDARD UNIT HAS BEEN APPROVED BY THE DIVISION</p>	

RECEIVED
2000 NOV -9 1 P 2:13
BUREAU OF LAND MGMT.
OFFICE OF RESOURCE AREA

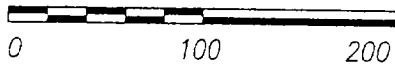
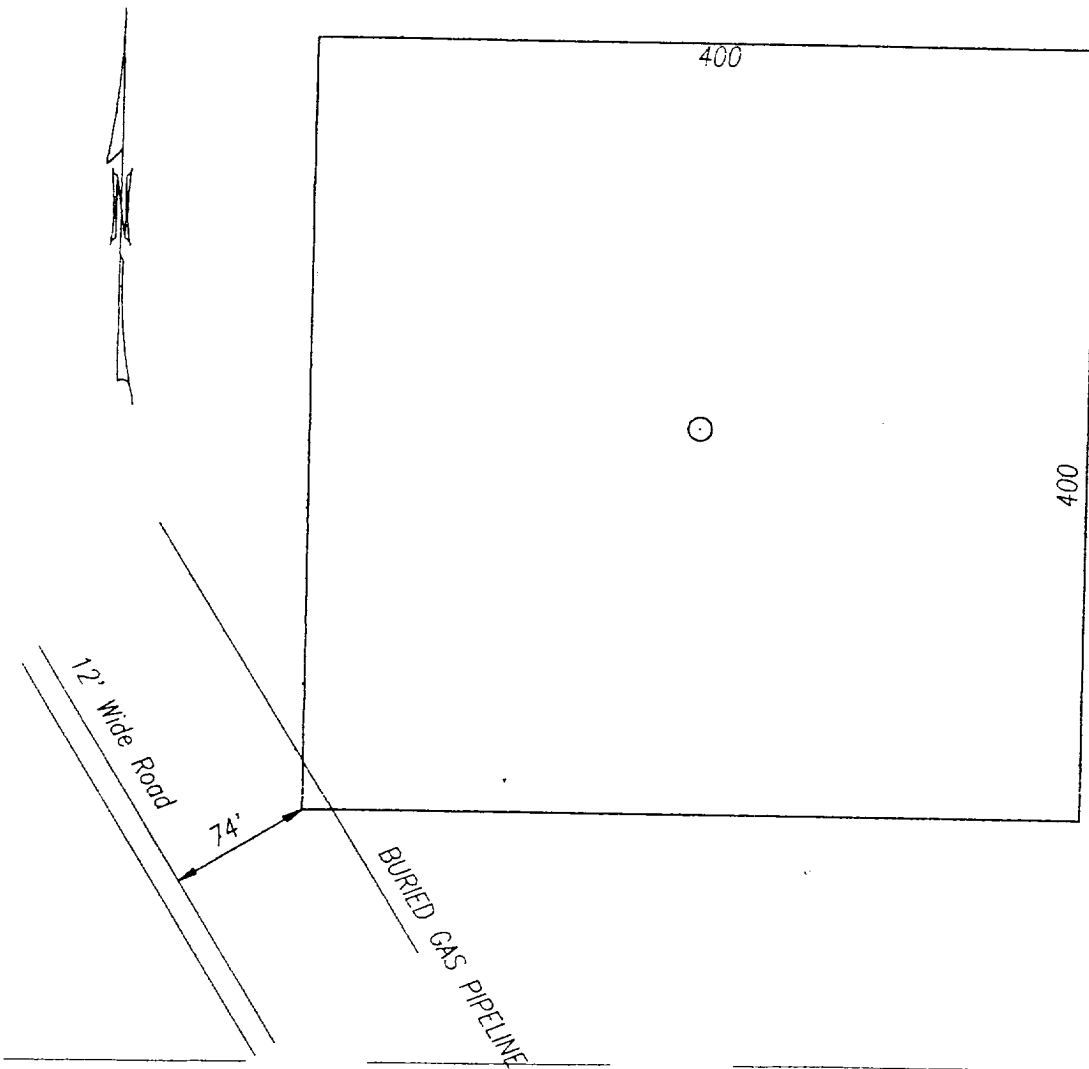

SITE PLAN
RAY WESTALL OPERATING
SANTA FE FEDERAL WELL No. 9
2310 FNL 640 FEL
SEC. 35, T22S, R28E
EDDY Co., NM

U.S.

U.S.

U.S.

Union Pacific
Barnes
4 3 78

Santa Fe
V.C.W.
10/23/80
10/23/80
10/23/80
10/23/80

Superior et al
due forms

BK Exo
(H.E. Yates et al)
6 7 2 7 8

Fortson
Red Arrow
TO 6330

26

MIDLAND MAP

RML Fed
U.S.

(Richardson C.)
B I G C
069159

Bass Ent

25

DR Bass
Sig Eddy
TO 6200
04/3-8-78

46

43 DR Bass
Big Eddy
TO 6300
04/5-8-78

117
● P4

Richardson C.
B I G C
069159

30

Iron Engr et al
1610.
Living Fed

Roy Westall

Hanley Pet
(Matador)
(Concho Res.)
960

(P78)
(WO)
(H 4 M) P31

(Hanley Pet.)
to 13,050'

35

Santa Fe Fed

Union Refed.

(Collins B. Ware, Y3)
Louis Dreyfus
Nat Gas

9

3479

36

H B Morrison
Gulf St
TO 2853
04/10 6-80

"Pinnacle St"

State

Louis Dreyfus
Nat Gas

61349

31

Quahada
Ridge-Fed U.S.

213972
296
113476
1346
119341

H.E. Yates et al

Bird Crk
Res

1-GO Lamoco
state
disc
del disc
P29

SWD

Bird
Creek
Res et al

(Pogo)
Pardue Morris
W.F. Morris
Pardue Farms

Worthog
St

Living St

Yates et al
1611 95
1611 95
3882
YB 487
3882

3951 4134 65 3134 3133 93

1

Chevron
18038

17

SWD

16

11

P52

Central Fed
U.S.

3645 420 24 3140 40

Louis Dreyfus Nat Gas

7 1 95
61349

3652 5

3657 6

6

Quahada Ridge-Fed
U.S.

Oryx
4
P16

BTA

Ram Ener
(Altura)

(Delta Dring)
Amoco-Fed
(S. San Disc)
(813)

Pardue
Farms

F175 10asures
Carrasco

32636

Chevron
18038

(Amoco) Southwestern
Energy

245

2

HIWAY 31

3638

To 2825
04/13/59

Santa Fe Ener
9
62 98

3728 3

Santa Fe Ener
Santa Fe Ener
(P78)
(85 disc)
(P78)
4 40

3742 4

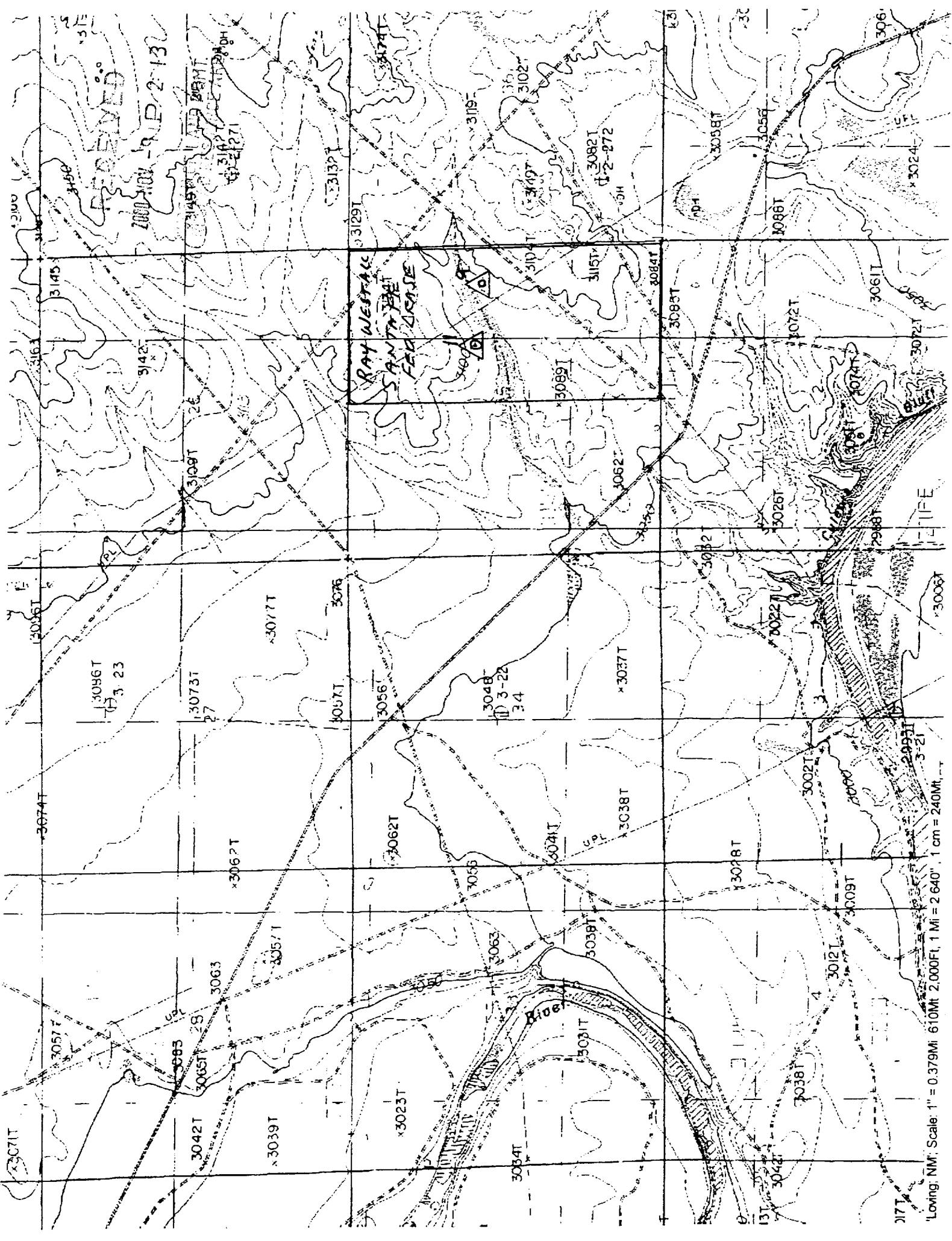

Loving, NM. Scale: 1" = 0.379Mi. 610Mtr. 2,000Ft. 1 Mi = 2,640". 1 cm = 240Mtr.

APPLICATION FOR DRILLING

Ray Westall
Santa Fe Federal No. 9
2237' FNL & 840' FEL
Section 35
Township 22 South, Range 28 East
Eddy County, New Mexico

In conjunction with Form 3160-3, Application for Permit to Drill, Ray Westall submits the following ten items of pertinent information in accordance with BLM requirements:

1. The geological surface formation is Quaternary.
2. The estimated tops of geologic markers are as follows:
 - Bell Canyon 2800'
 - Cherry Canyon 3750'
 - Brushy Canyon 4800'
 - Bone Springs 6325
3. The estimated depths at which anticipated water, oil & gas formations are expected to be encountered:
 - Water 0-180'
 - Oil & Gas Zones 2800-6325
4. Proposed casing program: See 3160-3
5. Pressure Control Equipment:
 - A 900s BOP will be installed on the 8 5/8" casing and tested prior to drill out.
6. Mud Program:
 - Fresh water in surface hole.
 - Brine in production hole.
7. Auxiliary Equipment: None
8. Logging Program: CNL/FDC/GR, DLL.
9. No abnormal pressures or temperatures are anticipated. Estimated BHP is 3100#, Estimated BHT is 125 F.
10. Anticipated Starting date: 01/01/01
 - Duration: 12 Days drilling
 - 5 Days completion

MULTI-POINT SURFACE USE AND OPERATIONS PLAN

RAY WESTALL SANTA FE FEDERAL NO. 9

This plan is submitted with form 3160-3, Application for Permit to Drill, covering the above described well. The purpose of this plan is to describe the location of the proposed well, the proposed construction activities and operations plan, the magnitude of surface disturbance involved, and the procedures to be followed in rehabilitating the surface after completion of the operations, so that a complete appraisal can be made of the environmental effect associated with the operation.

1. Existing Roads.
Exhibit A is a portion of a USGS topographic map showing the wells and roads in the vicinity of the proposed location.
2. Planned Access Road.
Approximately 300' of road will be constructed west from the main road.
3. Location of Existing Wells.
Exhibit B is a topo map showing the existing wells.
4. Location of existing/or proposed facilities:
If productive a 3" SDR 7 poly line will be laid along existing ROW to the battery located on the Santa Fe Federal #1 location. A 4 phase power line and poles will be routed along the existing ROW paralleling the road.
5. Location and Type of Water Supply.
It is planned to drill the proposed well with fresh and brine water system. The water will be obtained from commercial sources and will be hauled to the location by truck.
6. Source of Construction Materials.
The location and road will be from pit excavation and or will be hauled in from an approved caliche pit.
7. Methods of Handling Waste Disposal.
 - A. Drill cuttings will be disposed of in the reserve pit.
 - B. Drilling fluids will be allowed to evaporate in the reserve pits until the pits are dry.
 - C. Produced water during operations will be stored in reserve pits until dry.
 - D. Oil produced during operations will be stored in tanks until sold.
 - E. Current laws and regulations pertaining to the disposal of human waste will be complied with.

- F. Trash, waste paper, garbage and junk will be stored in a wire cage preventing blowing or scattering by the wind. After drilling and completion all waste will be removed to an approved site.

8. Ancillary Facilities

None required.

9. Wellsite Layout.

Exhibit C shows the relative location and dimensions of the well pad, the reserve pit, a 400' X 400' area has been staked and flagged.

10. Plans For Restoration of The Surface.

- A. After finishing drilling and completion operations all equipment and other material not needed for further operations will be removed. The location will be cleaned of all trash and junk to leave the Wellsite in as aesthetically pleasing a condition as possible.
- B. Unguarded pits, if any containing fluids will be fenced until they have been filled.
- C. If the proposed well is non-productive, all rehabilitation and or vegetation requirements of the BLM and USGS will be complied with and will be accomplished as expeditiously as possible. All pits will be filled and leveled within 90 days after abandonment.

11. Other Information:

- A. Topography: The land surface in the vicinity of the Wellsite is sandy loam with caliche hills and outcrops.
- B. Flora and Fauna: the vegetation cover consists of prairie grass, greasewood and miscellaneous desert growth. No wildlife was observed, but wildlife in the area probably includes those typical of semi-arid desert land. The area is used for cattle grazing.
- C. There are no ponds, lakes or rivers in the area.
- D. There are no inhabited dwellings in the vicinity of the proposed well.
- E. Surface ownership is federal.
- F. Evidence of archeological sites has been reported and previously filed by Archaeological Survey Consultants.

12. Operator's Representative:

Ray Westall
P.O. Box 4
Loco Hills, NM 88255
(505) 677-2370

13. Certification:

I hereby certify that I, or persons under my direct supervision, have inspected the proposed drillsite and access route, that I am familiar with the conditions which presently exist; that the statements made in this plan are to the best of my knowledge true and correct; and that the work associated with the operation proposed herein will be performed by the operator and its' subcontractors in conformity with this plan and the terms and conditions under witch is approved

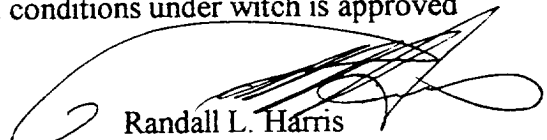

Randall L. Harris
Geologist

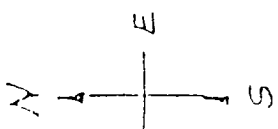

WEA DRILLING CO., INC.
RIG #1
LOCATION & MHD PIT SPECS

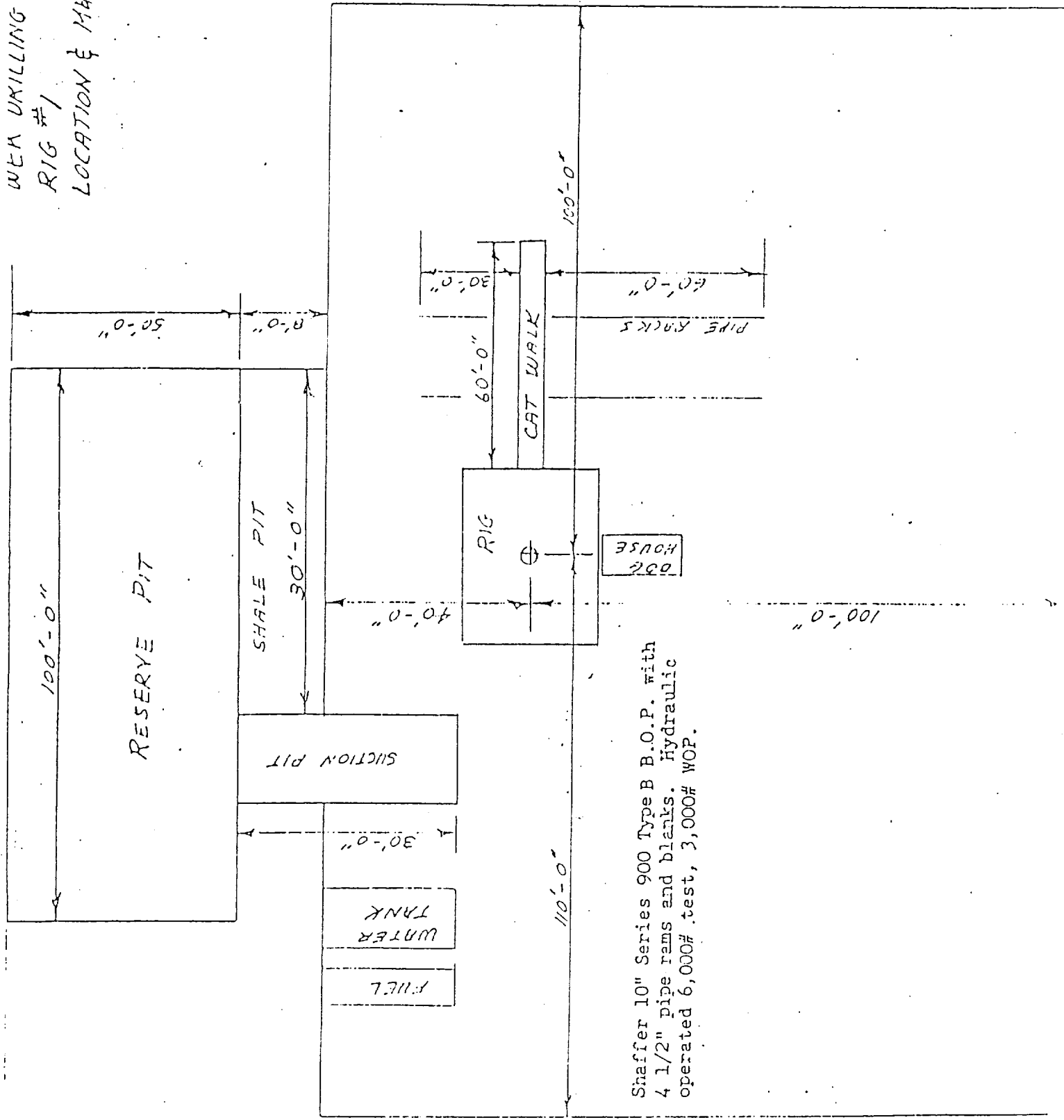

Shaffer 10" Series 900 Type B B.O.P. with
4 1/2" pipe rams and blanks. Hydraulic
operated 6,000# test, 3,000# WOP.

CRATING NO. 3
Revised April, 1971

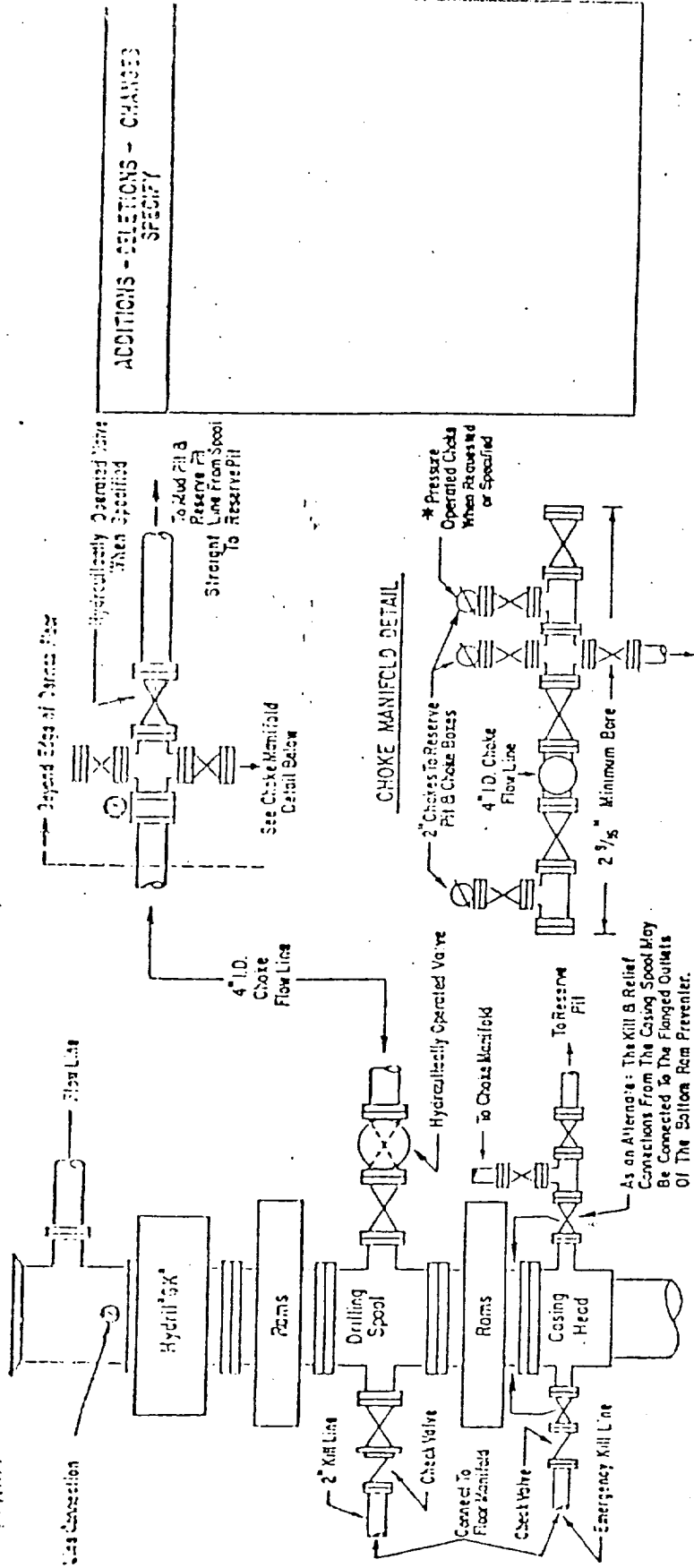

ADDITIONS - SELECTIONS - CHANGES
SPECIFY

3000 PSI WORKING PRESSURE
BLOWOUT PREVENTER HOOK-UP

The blowout preventer assembly shall consist of one blind ram preventer and one pipe ram preventer, both hydraulically operated, a Hydril 5K ram preventer, valves, chokes and connections as illustrated. If a tapered drill string is used, a ram preventer must be provided for each size of drill pipe. Casing and tubing rams to fit the preventer are to be available as needed. If correct in size, the flanged outlets of the ram preventer may be used for connecting to the 4-inch I.D. choke flow line and kill line, except when air or gas drilling. The substructure height shall be sufficient to install a rotating blowout preventer.

Minimum operating equipment for the preventers and hydraulically operated valves shall be as follows: (1) Multiple pumps, driven by a continuous source of power, capable of fluid charging the test accumulator volume from the nitrogen precharge pressure to its rated pressure within 10 minutes. Also, the pumps are to be connected to the hydraulic operating system which is to be a closed system. (2) Accumulators with a precharge of nitrogen of not less than 750 PSI and connected so as to receive the aforementioned fluid charge. With the charging pumps shut down, the pressurized fluid volume stored in the accumulators must be sufficient to close all the pressure-operated devices simultaneously within 10 percent of the original. (3) When required, an additional source of power, remote and equivalent, is to be available to operate the above pumps; or there shall be additional pumps operated by separate power and equal in performance capabilities.

The closing manifold and remote closing manifold shall have a separate control for each pressure-operated device. Controls are to be located, with control handles indicating open and closed positions. A pressure reducer and regulator must be provided for operating the Hydril 5K ram preventer. When requested, a second pressure reducer shall be available to limit operating fluid pressures to ram preventer. Gulf Legion No. 28 hydraulic oil, an equivalent or better, is to be used as the fluid to operate the hydraulic equipment.

The choke manifold, choke flow line, and choke lines are to be supported by metal stands and adequately anchored. The choke flow line and choke lines shall be constructed as straight as possible and without sharp bends. Easy and safe access is to be maintained to the choke manifold. All valves are to be selected for operation in the presence of oil, gas, and drilling fluids. The choke flow line valves connected to the drilling spool and all ram type preventers must be equipped with stem extensions, universal joints if needed, and hand wheels which are to extend beyond the edge of the derrick substructure. All other valves are to be equipped with handles.

* To include derrick floor mounted control.

RAY WESTALL OPERATING

HYDROGEN SULFIDE DRILLING PLAN

1. HYDROGEN SULFIDE TRAINING

All personnel that are connected with the drilling or completion of a well within a known H₂S area will receive training from a qualified instructor in the following areas prior to commencing drilling operations on this well:

- A. The hazards and characteristics of hydrogen sulfide.
- B. The proper use of personal protective equipment and life support systems.
- C. The proper use of H₂S detectors, alarms, warning systems, briefing areas, evacuation procedures, and prevailing winds.

There will be an initial training session just prior to encountering a known or probable H₂S zone (within 3 days) and weekly H₂S and well control drills for all personnel in each crew. The initial training session shall include a review of the site specific H₂S Drilling Plan. This plan shall be available at the well site. All personnel will be required to carry documentation that they have received the proper training.

2. H₂S SAFETY EQUIPMENT AND SYSTEMS

All H₂S safety equipment and systems will be installed, tested, and operational when drilling reaches a depth of 500 feet above, or three days prior to penetrating the first zone containing or reasonably expected to contain H₂S.

A. Well Control Equipment:

- a. Choke manifold with a minimum of one remote choke.
- b. Blind rams and pipe rams to accommodate all pipe sizes with properly sized closing unit.

- B. Protective equipment for essential personnel:
 - a. Mark II Surviveair 30 minute units located in the dog house and at briefing areas, as indicated on well site diagram.
- C. H₂S detection and monitoring equipment:
 - a. Two portable monitors positioned on location for best coverage and response. These units have warning lights and sirens when high levels of H₂S is detected.
- D. Visual warning systems:
 - a. Wind direction indicators as shown on well site diagram.
 - b. Caution/Danger signs shall be posted on roads providing direct access to location.
- E. Mud program:
 - a. There is no known high pressure in this drilling area or known high concentrations of H₂S that would necessitate any special drilling fluids.
- F. Metallurgy:
 - a. All drill stings, casings, tubing, wellhead, blowout preventers, drilling spool, kill lines, choke manifold and lines and valves shall be suitable for H₂S service.
- G. Communication:
 - a. Radio communications in company vehicles including cellular telephone and 2-way radio.
- H. Well testing:
 - a. There will be no DST's on this well.

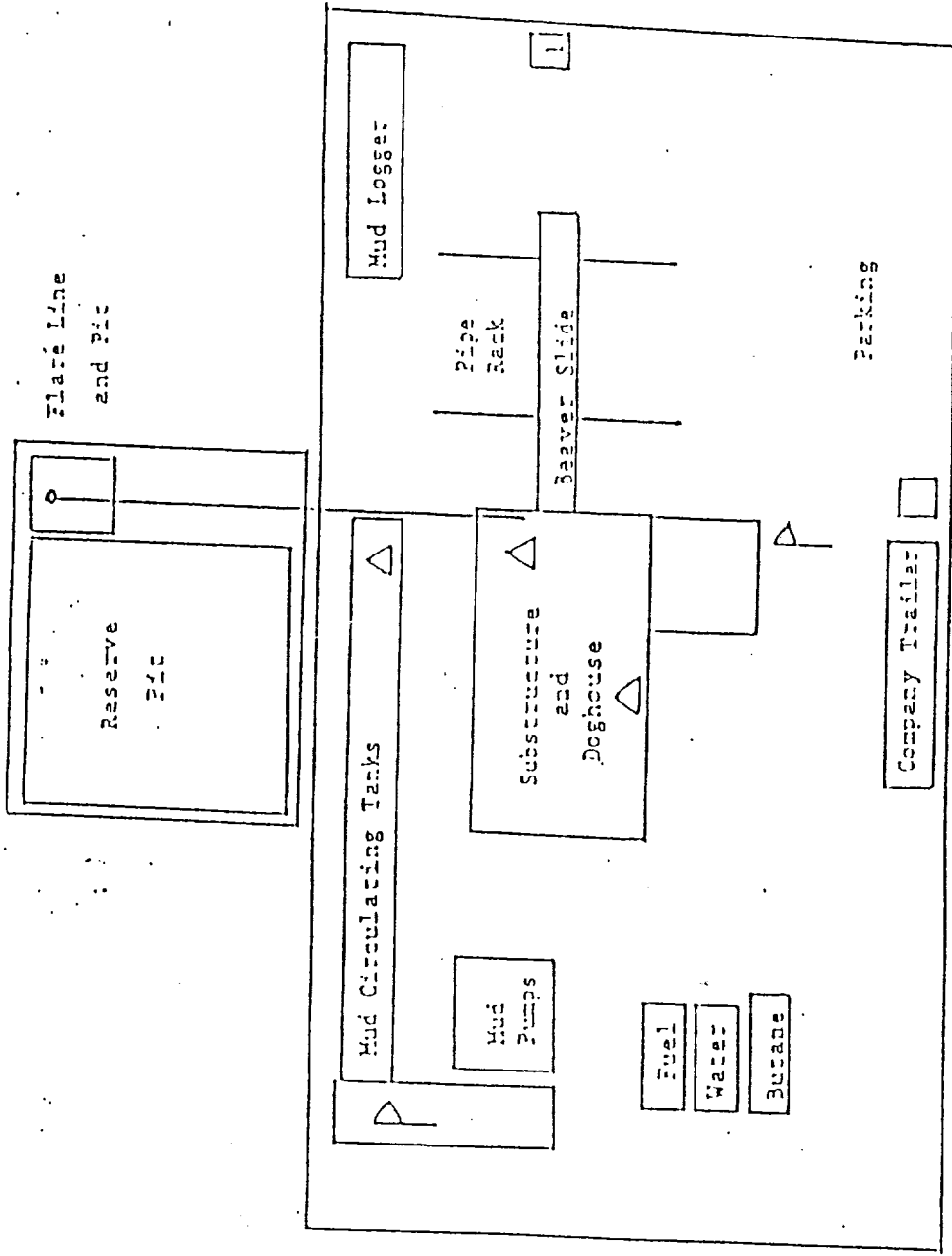

- △ - H2S Monitors with alarms at the bell nipple and shale shaker
- - Mud Direction Indicators
- - Safe zones with caution signs and protective bracing equipment. 150 feet from wellhead. 1 designates primary area