

submitted in lieu of Form 3160-5

UNITED STATES
DEPARTMENT OF THE INTERIOR
BUREAU OF LAND MANAGEMENT

Sundry Notices and Reports on Wells

1. Type of Well
GAS

2. Name of Operator
BURLINGTON RESOURCES OIL & GAS COMPANY

3. Address & Phone No. of Operator
PO Box 4289, Farmington, NM 87499 (505) 326-9700

4. Location of Well, Footage, Sec., T, R, M
1450' FSL, 1450' FWL, Sec.24, T-30-N, R-7-W, NMPM

5. Lease Number
SF-079382
If Indian, All. or Tribe Name
Unit Agreement Name

8. Well Name & Number
San Juan 30-6 Unit
San Juan 30-6 U #416

9. API Well No.
30-039-24183

10. Field and Pool
Basin Fruitland Coal

11. County and State
Rio Arriba Co, NM

RECEIVED
AUG 18 1999

OIL CON. DIV.
DIST. 3

12. CHECK APPROPRIATE BOX TO INDICATE NATURE OF NOTICE, REPORT, OTHER DATA

Type of Submission	Type of Action	
<input checked="" type="checkbox"/> Notice of Intent	<input type="checkbox"/> Abandonment	<input type="checkbox"/> Change of Plans
<input type="checkbox"/> Subsequent Report	<input type="checkbox"/> Recompletion	<input type="checkbox"/> New Construction
<input type="checkbox"/> Final Abandonment	<input type="checkbox"/> Plugging Back	<input type="checkbox"/> Non-Routine Fracturing
	<input type="checkbox"/> Casing Repair	<input type="checkbox"/> Water Shut off
	<input type="checkbox"/> Altering Casing	<input type="checkbox"/> Conversion to Injection
	<input checked="" type="checkbox"/> Other - liner cleanout	

13. Describe Proposed or Completed Operations

It is intended to clean out the liner of the subject well according to the attached procedure and wellbore diagram.

RECEIVED
RLM
99 AUG 12 PM 1:41
070 FARMINGTON, NM

14. I hereby certify that the foregoing is true and correct.

Signed Nancy Altmanns - for (DMFTC) Title Regulatory Administrator Date 8/11/99
no _____

(This space for Federal or State Office use) for
APPROVED BY [Signature] Title Lead Date 8/16/99
CONDITION OF APPROVAL, if any:

Title 18 U.S.C. Section 1001, makes it a crime for any person knowingly and willfully to make any department or agency of the United States any false, fictitious or fraudulent statements or representations as to any matter within its jurisdiction.

San Juan 30-6 #416
WORKOVER PROCEDURE
8/11/99

Unit K, Section 24, T30N-R7W, Rio Arriba County, New Mexico
Lat. 36.794739 / 36° 47.68'
Long. 107.525558 / 107° 31.53'

1. MIRU daylight recavitation rig.
2. RU flow lines to casing, record casing & tubing pressures, flow test casing and pitot test while rigging up.
3. NDWH / NU BOP. Kill if necessary with produced Fruitland coal water. Pressure test BOP's to 200 psi for 10 mins and 1500 psi for 30 mins using a pup joint screwed into the tubing hanger and the pipe rams.
4. RU blooie lines. RU pressure recorder on air injection line.
5. Pick up on and remove tubing hanger. TOOH and lay down the 2-7/8" x 3-1/2" tubing string.
6. TIH with a 4-3/4" bit, bit sub and 2-7/8" workstring. CO fill to PBSD @ 3122'. TOOH.
7. TIH with a mill or liner retrieving tool as required and perform one of the two following operations:

TIH with a mill. DCs and 2-7/8" workstring. Cut slips on top of liner hanger (see attached WB sketch and tally). TOOH. TIH with spear, bumper jars and jar liner until free or jars quit, whichever comes first. TOOH.

OR

TIH with liner retrieving tool and bumper sub w/ DP and collars as required. Screw into liner hanger and attempt to free. If not free, screw out of liner and TOOH. PU DCs and fishing tools (jars, accel., bumper sub., etc.) w/ liner retrieving tool & TIH. Screw into liner and jar until free or jars quit, which ever comes first. TOOH. Send the liner hanger in. If liner does not come free, contact office for sidetrack considerations.

If liner does not come free, run freepoint through bored out spear, determine stuck point and contact office for fishing or sidetrack decision based on freepoint information.

8. Pull liner a safe distance from surface (dependent upon flowing pressures, kill well with produced Fruitland coal water, check for flow, continue pumping into casing at a slow pump rate while laying down liner (record total volume of fluid pumped during laying down of liner). Send casing to BR yard. A redressed 15.5#, K-55 liner will be run in the well.
9. PU 6-1/4" mill, DC's and 2-7/8" workstring. TIH and clean out open hole with air/mist and water sweeps as hole dictates. Monitor pressure recorder for pressure increases as signs of hole bridging. Do not attempt to "force" the workstring to bottom. If the well is returning heavy amounts of coal, keep pipe above the coal zone and allow the well to flow and clean up on its own. Obtain an initial gas gauge and estimate water production when possible.

10. Rotate and reciprocate the pipe at all times during clean out. When the clean out process is complete (coal production is at a minimum or pitot has stabilized), begin circulating w/ air while rotating and reciprocating (R&R) until hole is stabilized. TOO H and prepare to run 5-1/2" liner. Obtain a gas gauge and estimate water production.

11. LINER RUNNING PROCEDURE:

DO NOT TAKE RISKS
EXTINGUISH ALL OPEN FLAMES
OPEN WELL THRU 2" LINES AND MANIFOLD LINES

Safe stripping pressure = Wt of liner/area of pipe

This pressure should be greater than the back pressure seen when flowing the well out the blooie lines. If back pressure is greater than the safe stripping pressure, snubbing should be done.

STRIPPING:

Rig up casing crew and change out stripping rubber to 5-1/2". Change out lower rams in upper BOP to 5-1/2". Run 5-1/2" liner through the 5-1/2" stripping rubber.

Pick up the liner hanger (steel sleeve), string float, and (1) one joint of drill pipe. Make up to 5-1/2" casing.

When liner hanger clears the upper BOP, close the top set of pipe rams. Change out stripping rubber to match DP and run remaining drill pipe.

Wash to TD with air/mist using water if necessary, set the liner hanger and release the setting tool. DO NOT ROLL THE HOLE WITH WATER. Trip out of the hole, laying down 2-7/8" workstring.

12. Pick up 2-7/8" tubing and a 4-3/4" mill and TIH. Mill plugs to PBTD. TOO H.

13. TIH w/ 2-3/8" tubing string configured for tubing insert pump and land 5' above PBTD @ 3117'. Purge valve will be on bottom, followed by pup joint, perforated sub, and seating nipple. Space out as needed with pup joints.

14. Hang tubing in donut. ND BOP / NUWH.

15. RDMO.

COMPLY WITH ALL FEDERAL, STATE AND LOCAL RULES AND REGULATIONS RELATING TO OIL AND GAS OPERATIONS.



Prepared: D.W. Mussett



Approved: Drilling Supt.

AIR CARE 1 INSTRUCTIONS

In Case of a Major Emergency Requiring Air Care 1:

1 Call 911

2 Give Location to Operator

Well Name: San Juan 30-6 #416

Latitude: 36 deg. 47.68 min.

Longitude: 107 deg. 31.53 min.

**3 Locate and prepare location for a helicopter
to land**

San Juan 30-6 #416
 August 11, 1999
 Undes. Fruitland Coal
 Unit K, Section 24, T30N, R7W, Rio Arriba County, New Mexico

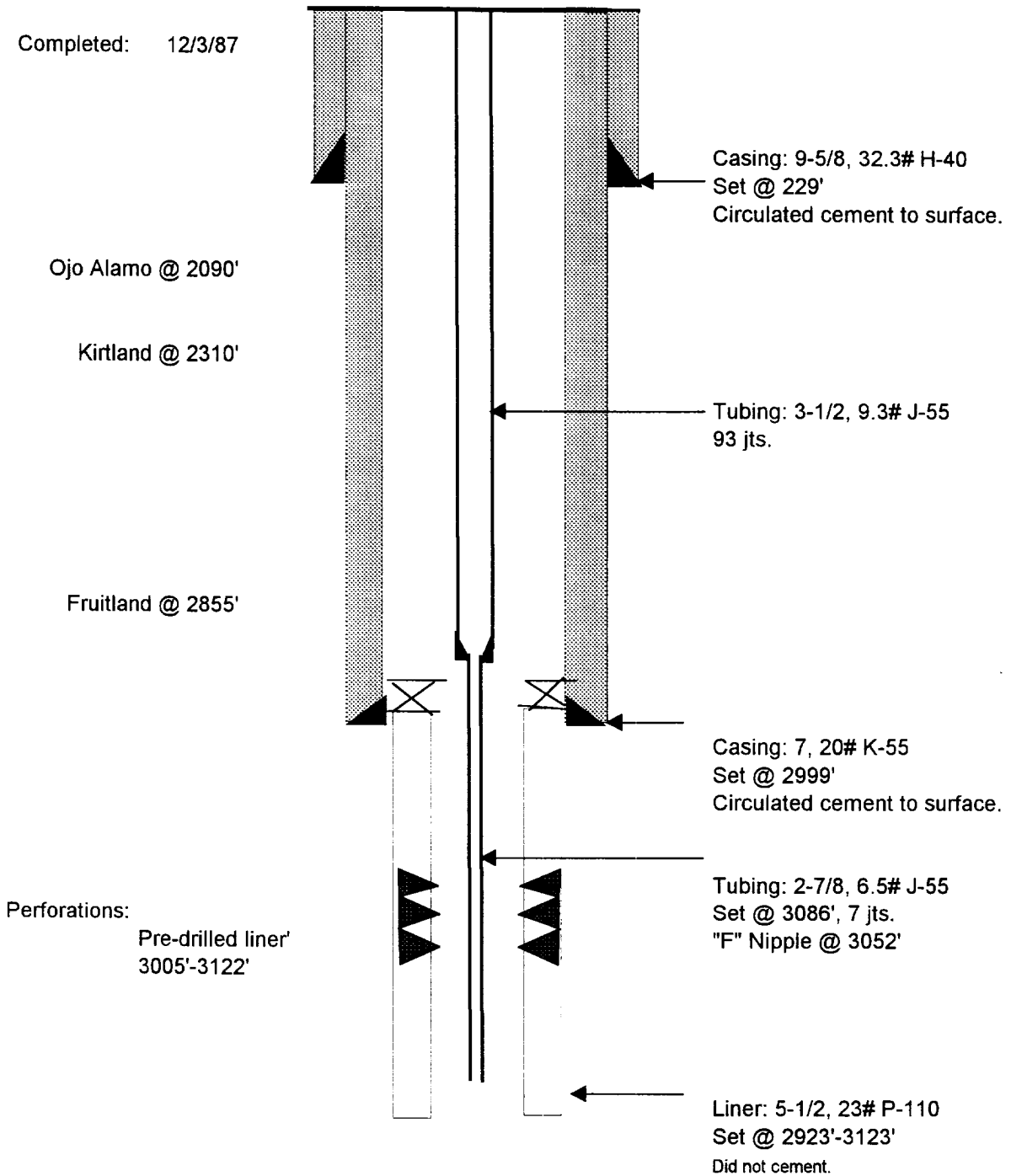

Workover History:
 6/99 Lower tubing 1 joint
 6/97 Replaced tbg.

PBTD 3122'
 TD 3123'