

RECEIVED:	REVIEWER:	TYPE:	APP NO:
-----------	-----------	-------	---------

ABOVE THIS TABLE FOR OCD DIVISION USE ONLY

NEW MEXICO OIL CONSERVATION DIVISION
 - Geological & Engineering Bureau -
 1220 South St. Francis Drive, Santa Fe, NM 87505



ADMINISTRATIVE APPLICATION CHECKLIST

THIS CHECKLIST IS MANDATORY FOR ALL ADMINISTRATIVE APPLICATIONS FOR EXCEPTIONS TO DIVISION RULES AND REGULATIONS WHICH REQUIRE PROCESSING AT THE DIVISION LEVEL IN SANTA FE

Applicant: XTO Permian Operating, LLC **OGRID Number:** 373075
Well Name: Multiple **API:** Multiple
Pool: Multiple **Pool Code:** Multiple

SUBMIT ACCURATE AND COMPLETE INFORMATION REQUIRED TO PROCESS THE TYPE OF APPLICATION INDICATED BELOW

- 1) **TYPE OF APPLICATION:** Check those which apply for [A]
 A. Location – Spacing Unit – Simultaneous Dedication
 NSL NSP (PROJECT AREA) NSP (PRORATION UNIT) SD
- B. Check one only for [I] or [II]
 [I] Commingling – Storage – Measurement
 DHC CTB PLC PC OLS OLM
 [II] Injection – Disposal – Pressure Increase – Enhanced Oil Recovery
 WFX PMX SWD IPI EOR PPR

- 2) **NOTIFICATION REQUIRED TO:** Check those which apply.
 A. Offset operators or lease holders
 B. Royalty, overriding royalty owners, revenue owners
 C. Application requires published notice
 D. Notification and/or concurrent approval by SLO
 E. Notification and/or concurrent approval by BLM
 F. Surface owner
 G. For all of the above, proof of notification or publication is attached, and/or,
 H. No notice required

<u>FOR OCD ONLY</u>	
<input type="checkbox"/>	Notice Complete
<input type="checkbox"/>	Application Content Complete

3) **CERTIFICATION:** I hereby certify that the information submitted with this application for administrative approval is **accurate** and **complete** to the best of my knowledge. I also understand that **no action** will be taken on this application until the required information and notifications are submitted to the Division.

Note: Statement must be completed by an individual with managerial and/or supervisory capacity.

Russell Young
 Print or Type Name

2/25/2026
 Date

Print or Type Name

832-302-5430
 Phone Number

Russell Young
 Signature

russell.young@exxonmobil.com
 e-mail Address



February 27, 2026

VIA ONLINE FILING

Albert C.S. Chang, Division Director
Oil Conservation Division
New Mexico Department of Energy, Minerals and Natural Resources
1220 South Saint Francis Drive
Santa Fe, NM 87505

Re: Application of XTO Permian Operating, LLC for administrative approval to surface commingle (pool and lease) oil and gas production from participating area comprised of Section 13 Township 22 South, Range 29 East and Sections 15, 16, 17 and 18 Township 22 South, Range 30 East, NMPM, Eddy County, New Mexico.

Dear Mr. Chang:

XTO Permian Operating, LLC (OGRID No. 373075) (“XTO”), pursuant to 19.15.12.10 NMAC, seeks administrative approval to surface commingle (on lease) diversely owned oil and gas production at the James Ranch Unit DI 11 Central Tank Battery (CTB) *insofar as all existing and future wells drilled in the following spacing units:*

- (a) The **10,613.77 acres**, of Participating Area **NMNM 0709650** comprised of N/2 S/2 Section 13 of Township 22S Range 29E; S/2 SW/4 Section 14; All Section 15; All Section 16; SW/4, E/2 Section 17; Lot 3-4, E/2 SW/4, SE/4 (ada: S/2) Section 18; Lots 1-4, E/2 W/2, E/2 (ada: All) Section 19; All Section 20; All Section 21; All Section 22; W/2, S/2, SE/4 Section 23; S/2 S/2 Section 24; All Section 26; All Section 27; E/2 Section 28; N/2 NE/4, NE/4 NW/4, Section 35; N/2 NW/4, SE/4 NW/4, N/2 SW/4, SE/4 SW/4, E/2 Section 36; of Township 22S Range 30E; Lots 1-4, E/2 W/2, E/2 (ada;All) Section 31 of Township 22S Range 31E; Lot 4, SW/4 NW/4, W/2 SW/4 (ada; W/2 W/2) Section 5; Lot 1-7, SE/4 NW/4, E/2 SW/4, S/2 NE/4, SE/4 (ada: All) Section 6; Lot 1-4, E/2 W/2, E/2 (ada: ALL) Section 7; W/2 Section 8; NW/4 Section 17; Lot 1-2, E/2 NW/4, NE/4 (ada: N/2) Section 18 of Township 23S Range 31E; in the **[97905] WILDCAT G-07 S223021G; BONE SPRING**– currently dedicated to the following wells:

3001546283	JAMES RANCH UNIT DI 11 WHITLASH	515H
3001549038	JAMES RANCH UNIT DI 11 EKALAKA	821H
3001549037	JAMES RANCH UNIT DI 11 EKALAKA U	822H

XTO Permian Operating, LLC.
Russell Young
3617 North Big Spring Street
Midland, TX 79707
832-302-5430
Russell.young@exxonmobil.com

3001549036	JAMES RANCH UNIT DI 11 EKALAKA	823H
3001549033	JAMES RANCH UNIT DI 11 EKALAKA	824H
3001549032	JAMES RANCH UNIT DI 11 EKALAKA	923H
3001549039	JAMES RANCH UNIT DI 11 EKALAKA	921H
3001549035	JAMES RANCH UNIT DI 11 EKALAKA	922H
3001557276	JAMES RANCH UNIT DI 11 EKALAKA	701H
3001557277	JAMES RANCH UNIT DI 11 EKALAKA	702H
3001557280	JAMES RANCH UNIT DI 11 EKALAKA	703H
3001546284	JAMES RANCH UNIT DI 11 WHITLASH A	715H

- (b) The **10,373.77 acres**, of Participating Area **NMNM 070965L** comprised of N/2 S/2 Section 13 of Township 22S Range 29E; All Section 15; All Section 16; SW/4, E/2 Section 17; Lot 3-4, E/2 SW/4, SE/4 (ada: S/2) Section 18; Lots 1-4, E/2 W/2, E/2 (ada: All) Section 19; All Section 20; All Section 21; All Section 22; W/2 Section 23; All Section 26; All Section 27; E/2 Section 28; N/2 NE/4, NE/4 NW/4, S/2 SE/4 Section 35; N/2 NW/4, SE/4 NW/4, NE/4 SW/4, S/2 SW/4, E/2 Section 36; of Township 22S Range 30E; Lots 1-4, E/2 W/2, E/2 (ada:All) Section 31 of Township 22S Range 31E; Lot 4, SW/4 NW/4, W/2 SW/4 (ada: W/2 W/2) Section 5; Lot 1-7, SE/4 NW/4, E/2 SW/4, S/2 NE/4, SE/4 (ada: All) Section 6; Lot 1-4, E/2 W/2, E/2 (ada: ALL) Section 7; W/2 Section 8; NW/4 Section 17; Lot 1-2, E/2 NW/4, NE/4 (ada: N/2) Section 18 of Township 23S Range 31E; in the **[96336] LOS MEDANOS; WOLFCAMP, SOUTH; AND [98344] WC 015 G08 S223017 K WOLFCAMP** – currently dedicated to the following wells:

3001549040	JAMES RANCH UNIT DI 11 EKALAKA	121H
3001549034	JAMES RANCH UNIT DI 11 EKALAKA	122H
3001549124	JAMES RANCH UNIT DI 11 EKALAKA	123H
3001546377	JAMES RANCH UNIT DI 11 WHITLASH	251H

Pursuant to 19.15.12.10.C(4)(g), *from all future additions of pools, leases or leases and pools to the James Ranch Unit DI 11 Central Tank Battery (CTB)* with notice provided only to the owners of interests to be added.

Oil and gas production from these spacing units will be commingled and sold at the Battery, located in the NESE of Section 17, T22S, R30E. XTO plans to use the well test method for allocation of production and measurement purposes. Production will flow from the wellbore to either a test separator or bulk (common) production separator. The test separator will separate the gas, oil, and water. Gas production from the test separator will be metered with a calibrated orifice meter that is manufactured to AGA specifications. Oil production from the test separator will be metered using a Coriolis meter. Gas and oil production will then be allocated daily based on the most recent individual well tests of oil, gas and water.

Exhibit 1 is a land plat showing XTO's current development plan, well pads, and the central Tank battery ("CVB Site") in the subject area. The plat also identifies the wellbores and lease/spacing unit boundaries.

Exhibit 2 is a completed Application for Surface Commingling (Diverse Ownership) Form C-107-B, that includes a statement from Steven D. Wolfe, Senior Facilities Engineer with XTO, explaining how XTO plans to utilize the well test method and the measurement devices to be utilized, along with a detailed schematic of the surface facilities (Attachment A to the statement).

Ownership is diverse between the above-described spacing units, each of which are either subject to a pooling agreement or a pooling order and are therefore considered "leases" as defined by 19.15.12.7(C) NMAC. **Exhibit 3**

XTO Permian Operating, LLC.
 Russell Young
 3617 North Big Spring Street
 Midland, TX 79707
 832-302-5430
 Russell.young@exxonmobil.com

is a list of the interest owners (including any owners of royalty or overriding royalty interest) affected by this application, an example of the letters sent by certified mail advising the interest owners that any objections must be filed in writing with the Division within 20 days from the date the Division receives this application, and proof of mailing. A copy of this application has been provided to the Bureau of Land Management since federal lands are involved.

Thank you for your consideration of this application. For questions concerning this application, please contact Marie Florez at marie.florez@exxonmobil.com or (505) 419-8420.

Sincerely,

Russell Young

Russell Young
New Mexico Commingle Manager
Permian Business Unit

XTO Permian Operating, LLC.
Russell Young
3617 North Big Spring Street
Midland, TX 79707
832-302-5430
Russell.young@exxonmobil.com



James Ranch Unit DI 11 Central Tank Battery (CTB) Lease Map

EDDY COUNTY, NM

- Legend**
- OIL FMP/SALES METER (3)
 - GAS FMP/SALES METER (2)
 - CTB SITE
 - WELL PADS
 - (NMNM105728035/NMNM 070965L)
 - (NMNM105721670/NMNM 070965O)
 - STATE SURFACE & MINERAL LEASE
 - FEDERAL SURFACE & MINERAL LEASE
 - JAMES RANCH UNIT

New Wells

API	WELL NAME	Well #	Pad Name
3001549040000	JAMES RANCH UNIT DI 11 EKALAKA	121H	A
30015490340000	JAMES RANCH UNIT DI 11 EKALAKA	122H	A
30015491240000	JAMES RANCH UNIT DI 11 EKALAKA	123H	A
30015572760000	JAMES RANCH UNIT DI 11 EKALAKA	701H	A
30015572770000	JAMES RANCH UNIT DI 11 EKALAKA	702H	A
30015572800000	JAMES RANCH UNIT DI 11 EKALAKA	703H	A
30015490380000	JAMES RANCH UNIT DI 11 EKALAKA	821H	A
30015490360000	JAMES RANCH UNIT DI 11 EKALAKA	823H	A
30015490330000	JAMES RANCH UNIT DI 11 EKALAKA	824H	A
30015490390000	JAMES RANCH UNIT DI 11 EKALAKA	921H	A
30015490350000	JAMES RANCH UNIT DI 11 EKALAKA	922H	A
30015490320000	JAMES RANCH UNIT DI 11 EKALAKA	923H	A
30015490370000	JAMES RANCH UNIT DI 11 EKALAKA U	822H	A
30015463770000	JAMES RANCH UNIT DI 11 WHITLASH	251H	A
30015462830000	JAMES RANCH UNIT DI 11 WHITLASH	515H	A
30015462840000	JAMES RANCH UNIT DI 11 WHITLASH A	715H	A

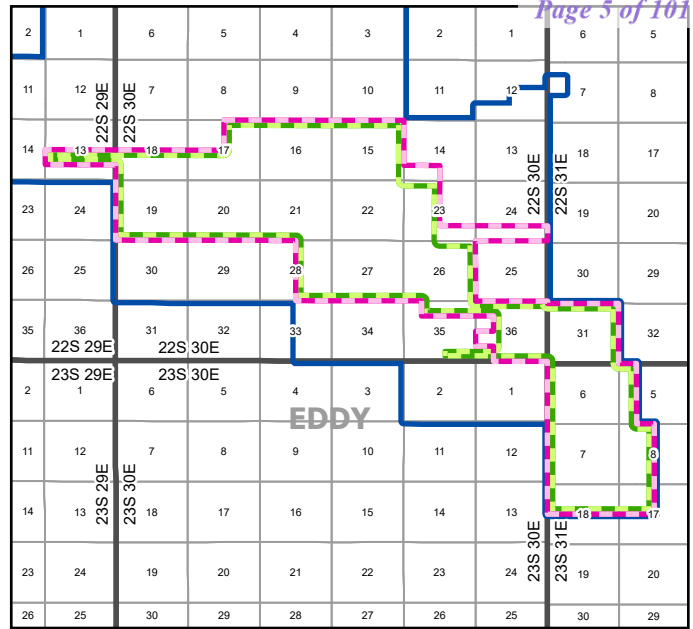
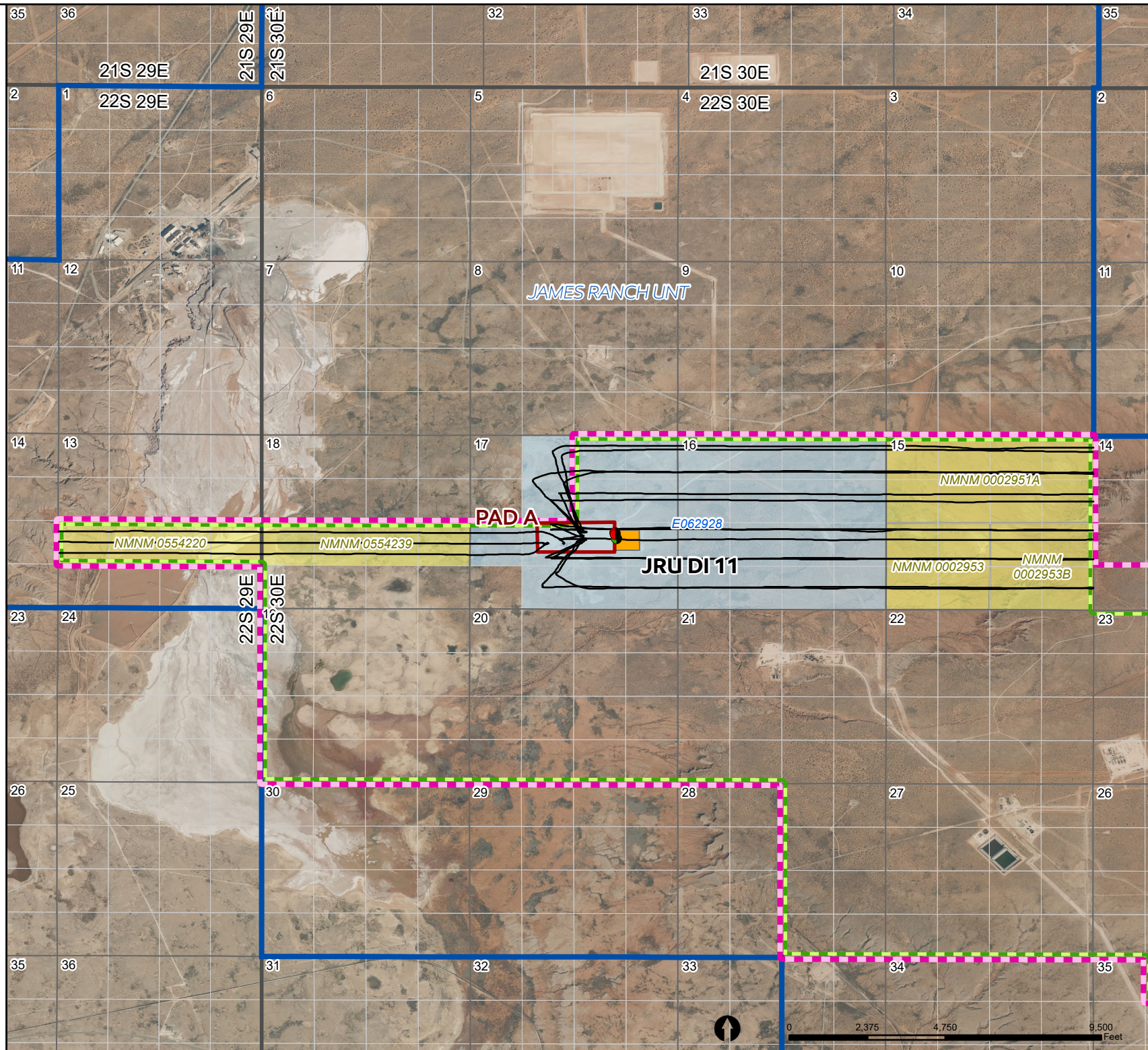

- (NMNM105728035/NMNM 070965L)
- (NMNM105721670/NMNM 070965O)

Santa Fe Main Office
 Phone: (505) 476-3441
 General Information
 Phone: (505) 629-6116

State of New Mexico
 Energy, Minerals and Natural Resources Department

Form C-107-B
 Revised August 1, 2011

OIL CONSERVATION DIVISION
 1220 S. St Francis Drive
 Santa Fe, New Mexico 87505

Submit the original application to the Santa Fe office with one copy to the appropriate District Office.

Online Phone Directory Visit:
<https://www.emnrd.nm.gov/oed/contact-us/>

APPLICATION FOR SURFACE COMMINGLING (DIVERSE OWNERSHIP)

OPERATOR NAME: XTO Permian Operating, LLC
 OPERATOR ADDRESS: 3617 North Big Spring Street, Midland TX 79707
 APPLICATION TYPE:
 Pool Commingling Lease Commingling Pool and Lease Commingling Off-Lease Storage and Measurement (Only if not Surface Commingled)
 LEASE TYPE: Fee State Federal

Is this an Amendment to existing Order? Yes No If "Yes", please include the appropriate Order No. _____
 Have the Bureau of Land Management (BLM) and State Land office (SLO) been notified in writing of the proposed commingling
 Yes No

(A) POOL COMMINGLING
 Please attach sheets with the following information

(1) Pool Names and Codes	Gravities / BTU of Non-Commingled Production	Calculated Gravities / BTU of Commingled Production		Calculated Value of Commingled Production	Volumes
Los Medanos; Wolfcamp, South [96336]	45/1159	45/1275		\$66.68	
WC 015 G08 S223017 K Wolfcamp [98344]	45/1159			\$2.84	
Wildcat G-07 S223021G; Bone Spring [97905]	50/1295				

(2) Are any wells producing at top allowables? Yes No
 (3) Has all interest owners been notified by certified mail of the proposed commingling? Yes No.
 (4) Measurement type: Metering Other (Specify) Well Testing
 (5) Will commingling decrease the value of production? Yes No If "yes", describe why commingling should be approved

(B) LEASE COMMINGLING
 Please attach sheets with the following information

(1) Pool Name and Code.
 (2) Is all production from same source of supply? Yes No
 (3) Has all interest owners been notified by certified mail of the proposed commingling? Yes No
 (4) Measurement type: Metering Other (Specify)

(C) POOL and LEASE COMMINGLING
 Please attach sheets with the following information

(1) Complete Sections A and E.

(D) OFF-LEASE STORAGE and MEASUREMENT
 Please attached sheets with the following information

(1) Is all production from same source of supply? Yes No
 (2) Include proof of notice to all interest owners.

(E) ADDITIONAL INFORMATION (for all application types)
 Please attach sheets with the following information

(1) A schematic diagram of facility, including legal location.
 (2) A plat with lease boundaries showing all well and facility locations. Include lease numbers if Federal or State lands are involved.
 (3) Lease Names, Lease and Well Numbers, and API Numbers.

I hereby certify that the information above is true and complete to the best of my knowledge and belief.

SIGNATURE: Russell Young TITLE: New Mexico Commingle Manager DATE: 2/25/2026
 TYPE OR PRINT NAME Russell Young TELEPHONE NO.: 832-302-5430
 E-MAIL ADDRESS: russell.young@exxonmobil.com

APPLICATION FOR COMMINGLING AND ALLOCATION APPROVAL

James Ranch Unit DI 11

List of Leases to be included in CAA:

Lease Type	Lease Number	Formation	Land Description	Type of Product	Proportional Interest	Federal Royalty Rate %	Dedicated Acreage
PA	PA NMNM105728035; Legacy NMNM 070965L	Wolfcamp	T22S, R29E, N.M.P.M. Sec. 13: N/2 S/2 T22S, R30E, N.M.P.M. Sec. 15: All; Sec. 16: All; Sec. 17: SW/4, E/2; Sec. 18: L3-L4, E/2 SW/4, SE/4 (ada: S/2); Sec. 19: L1-L4, E/2 W/2, E/2 (ada: All); Sec. 20: All; Sec. 21: All; Sec. 22: All; Sec. 23: W/2; Sec. 26: All; Sec. 27: All; Sec. 28: E/2; Sec. 35: N/2 NE/4, NE/4 NW/4, S/2 SE/4; Sec. 36: N/2 NW/4, SE/4 NW/4, NE/4 SW/4, S/2 SW/4, E/2 T22S, R31E, N.M.P.M. Sec. 31: L1-L4, E/2 W/2, E/2 (ada: All) T23S, R31E, N.M.P.M. Section 5: Lot 4; SW/4 NW/4, W/2 SW/4 (ada: W/2 W/2); Sec. 6: L1-L7, SE/4 NW/4, E/2 SW/4, S/2 NE/4, SE/4 (ada: All); Sec. 7: L1-L4, E/2 W/2, E/2 (ada: All); Sec. 8: W/2; Sec. 17: NW/4; Sec. 18: L1-L2, E/2 NW/4, NE/4 (ada: N/2)	Oil & Gas	Federal - 83.4197% State - 16.1947% Fee - 0.3856%	Federal - 12.5%	10,373.77
					100%		
PA	PA NMNM105721670; Legacy NMNM 070965O	Bone Spring	T22S, R29E, N.M.P.M. Sec. 13: N/2 S/2 T22S, R30E, N.M.P.M. Sec. 14: S/2 SW/4; Sec. 15: All; Sec. 16: All; Sec. 17: SW/4, E/2; Sec. 18: L3-L4, E/2 SW/4, SE/4 (ada: S/2); Sec. 19: L1-L4, E/2 W/2, E/2 (ada: All); Sec. 20: All; Sec. 21: All; Sec. 22: All; Sec. 23: W/2, S/2 SE/4; Sec. 24: S/2 S/2; Sec. 26: All; Sec. 27: All; Sec. 28: E/2; Sec. 35: N/2 NE/4, NE/4 NW/4; Sec. 36: N/2 NW/4, SE/4 NW/4, N/2 SW/4, SE/4 SW/4, E/2 T22S, R31E, N.M.P.M. Sec. 31: L1-L4, E/2 W/2, E/2 (ada: All) T23S, R31E, N.M.P.M. Section 5: Lot 4; SW/4 NW/4, W/2 SW/4 (ada: W/2 W/2); Sec. 6: L1-L7, SE/4 NW/4, E/2 SW/4, S/2 NE/4, SE/4 (ada: All); Sec. 7: L1-L4, E/2 W/2, E/2 (ada: All); Sec. 8: W/2; Sec. 17: NW/4; Sec. 18: L1-L2, E/2 NW/4, NE/4 (ada: N/2)	Oil & Gas	Federal - 83.7946% State 15.8285% Fee - 0.3769	Federal - 12.5%	10,613.77

List of Wells to be included in CAA with Production Volumes

JAMES RANCH UNIT DI 11 BATTERY							
API	Well Name	Well Number	Pool Name	Pool Code	BPD	MCFD	ACTUAL/PROJECTED
3001549040	JAMES RANCH UNIT DI 11 EKALAKA	121H	LOS MEDANOS; WOLFCAMP, SOUTH	96336	385.97	1109.37	Actual
3001549034	JAMES RANCH UNIT DI 11 EKALAKA	122H	WC 015 G08 S223017 K WOLFCAMP	98344	343.7	889.79	Actual
3001549124	JAMES RANCH UNIT DI 11 EKALAKA	123H	WC 015 G08 S223017 K WOLFCAMP	98344	453.32	1284.49	Actual
3001546377	JAMES RANCH UNIT DI 11 WHITLASH	251H	WC 015 G08 S223017 K WOLFCAMP	98344	387.68	998.83	Actual
3001549038	JAMES RANCH UNIT DI 11 EKALAKA	821H	WILDCAT G-07 S223021G; BONE SPRING	97905	443.7	1158.94	Actual
3001549037	JAMES RANCH UNIT DI 11 EKALAKA U	822H	WILDCAT G-07 S223021G; BONE SPRING	97905	1028	1542	Projected
3001549036	JAMES RANCH UNIT DI 11 EKALAKA	823H	WILDCAT G-07 S223021G; BONE SPRING	97905	1361	2041	Projected
3001549033	JAMES RANCH UNIT DI 11 EKALAKA	824H	WILDCAT G-07 S223021G; BONE SPRING	97905	1361	2041	Projected
3001549032	JAMES RANCH UNIT DI 11 EKALAKA	923H	WILDCAT G-07 S223021G; BONE SPRING	97905	294.55	744.08	Actual
3001549039	JAMES RANCH UNIT DI 11 EKALAKA	921H	WILDCAT G-07 S223021G; BONE SPRING	97905	392.05	774.23	Actual
3001549035	JAMES RANCH UNIT DI 11 EKALAKA	922H	WILDCAT G-07 S223021G; BONE SPRING	97905	187.63	914.69	Actual
3001557276	JAMES RANCH UNIT DI 11 EKALAKA	701H	WILDCAT G-07 S223021G; BONE SPRING	97905	454.96	1100.87	Actual
3001557277	JAMES RANCH UNIT DI 11 EKALAKA	702H	WILDCAT G-07 S223021G; BONE SPRING	97905	548.04	1312.62	Actual
3001557280	JAMES RANCH UNIT DI 11 EKALAKA	703H	WILDCAT G-07 S223021G; BONE SPRING	97905	357.87	824.98	Actual
3001546283	JAMES RANCH UNIT DI 11 WHITLASH	515H	WILDCAT G-07 S223021G; BONE SPRING	97905	494.68	1314.91	Actual
3001546284	JAMES RANCH UNIT DI 11 WHITLASH A	715H	WILDCAT G-07 S223021G; BONE SPRING	97905	359.44	854.66	Actual

Facility Process Flow and Measurement

The production from each well will flow from its respective surface hole location through a flowline to an inlet header at the facility. The inlet header directs the well production into either a test separator or bulk (common) production separator. If a well is not directed to the test separator, the flow is directed into the bulk production separator.

The test separator is a horizontal vessel where the gas, oil, and water are separated and measured. The gas flow is measured using an orifice meter following API Standard MPMS14.3.2 and the flow is calculated using an electronic flow meter (EFM). The oil flow is measured using a meter following the API Standard MPMS 5.6. The water flow is measured using a meter. Well test by separating and metering the oil production from the well for either (a) a minimum of twenty-four (24) consecutive hours; or (b) a combination of nonconsecutive periods that meet the following conditions: (i) each period shall be a minimum of six (6) hours; and (ii) the total duration of the nonconsecutive periods shall be a minimum of eighteen (18) hours. The Well Test Method used follows the API Standard MPMS 20.1 and meets state and federal regulations.

At the facility production is separated into oil, gas and water. The oil then flows into a heater treater. From the heater treater the oil is routed to a Vapor Recovery Tower (VRT) and then transferred into the oil pipeline using a LACT unit used as an FMP/sales meter.

The facility design has common ancillary equipment that includes—vapor recovery units, flares, and a water system. The flash gas is metered and then will enter the primary gas line after all FMPs / sales meter.

Reservoir Forecasted Declines

These wells may produce high volumes for a short three-month period and are then expected to decline for the remaining life of each well. After the initial period of hyperbolic decline, production stabilizes at a more predictable exponential decline rate.

Production and Allocation

Based on the decline rates, the wells will be tested at differing frequencies for optimum accuracy. Well tests will be for either (a) a minimum of twenty-four (24) consecutive hours; or (b) a combination of nonconsecutive periods that meet the following conditions: (i) each period shall be a minimum of six (6) hours; and (ii) the total duration of the nonconsecutive periods shall be a minimum of eighteen (18) hours. Based on the production decline, the following three periods will be used to determine well test frequency:

- Range 1 – Initial Production Period – from the first production until the earlier of either the peak production rate or thirty (30) days after the first production; minimum 10 well tests/per month
- Range 2 – Plateau Period – the end of the initial production period to the peak decline rate; minimum 3 well tests/per month
- Range 3 – Decline Period – the end of plateau period until well is plugged and abandoned; minimum 3 well tests/per month when the decline rate is >22% per month, 2 well tests/per month when the decline rate is between 22%-10% per month, and 1 well test/per month when the decline rate is <10% per month

Methodology

Gas and oil production will then be allocated daily based on the most recent individual well tests of oil, gas and water. The time increment for reported sales through the sales meters is monthly. Allocation methods are explained in the white and blue rows above the table and the data within the table can be identified as such: all calculated data is in green text and statement/meter data is in blue text.

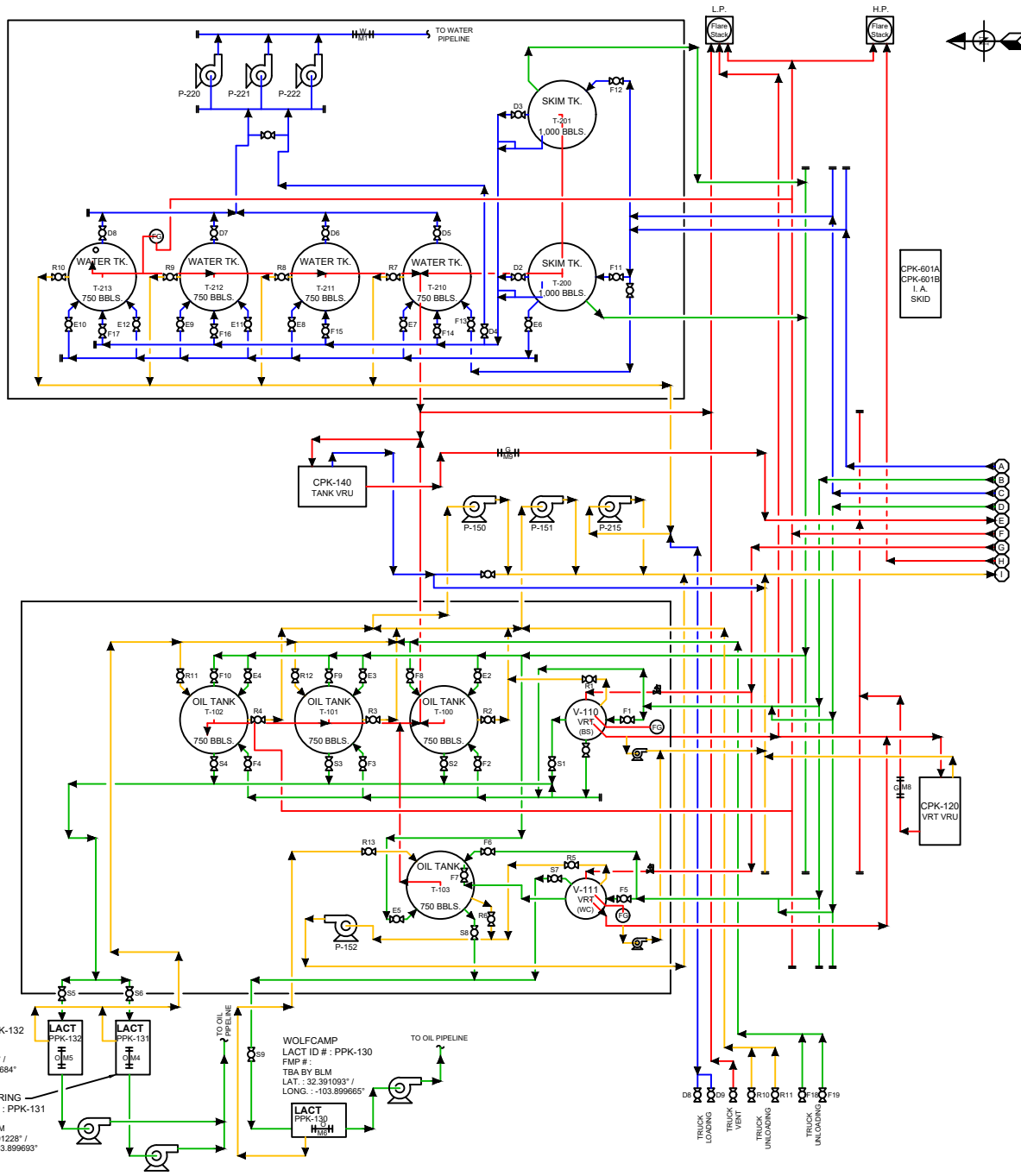

LACT Valve Phase Details			
Valve ID	Fill	Recycle	Sales/Drain
F1-10, 18, 19	O/C	S/C	S/C
F11-17	O/C	S/C	S/C
E2-12	O/C	O/C	O/C
R1-13	S/C	O/C	S/C
D2-8	S/C	S/C	O/C
S1-9	S/C	S/C	O/C

O=Open, S/O=Sealed Open, C=Closed, S/C=Sealed Closed, O/C=Opened or Closed

DRAWING ID	METER DESCRIPTION	TYPE	METER ID #	PURPOSE
GM8	VRT VRU CPK-120 (SICK)	ULTRASONIC	DBJR0165G	PRODUCTION
GM9	TANK VRU CPK-140 (SICK)	ULTRASONIC	DBJR0166G	PRODUCTION
OM1	TEST SEPARATOR V-80000 (O.O.S.)	CORIOLIS	DBJR01600	ALLOCATION
OM2	TEST SEPARATOR V-80001 (O.O.S.)	CORIOLIS	DBJR01610	ALLOCATION
OM4	BONE SPRING LACT UNIT PPK-131 - FMP	CORIOLIS	DBJR02530L	SALES
OM5	BONE SPRING LACT UNIT PPK-132 - FMP	CORIOLIS	DBJR02540L	SALES
OM6	WOLFPCAMP LACT UNIT PPK-130 - FMP	CORIOLIS	DBJR01880L	SALES
WM1	BATTERY WATER TRANSFER	TURBINE	--	PRODUCTION

FACILITY GAS USAGE	
ROYALTY FREE EQUIPMENT	USAGE
V-500 HEAT_TREAT.	11.8 MCFD
V-501 HEAT_TREAT.	11.8 MCFD
HP & LP FLARE PILOTS	1.2 MCFD

NOTES:
 1. HEATER TREATER USAGE BASED ON MANUFACTURERS RECOMMENDED SPECIFICATIONS.
 2. FLARE PILOTS USAGE BASED ON MANUFACTURERS RECOMMENDED SPECIFICATIONS.

EMULSION
 WATER
 OIL
 GAS

Revision	Description of Change	Date	By	ENG APPD. By
0	AS-BUILT	10/26/2022	TDM	
1	ADDED GAS METERS	8/21/2023	TDM	
2	ADDED LG. DUMP / REVISED	7/18/2025	TDM/SB	
3	ISSUED FOR REF.	2/4/2026	JLF	

JAMES RANCH UNIT DI 11
 CENTRAL TANK BATTERY - TANKS
 EDDY COUNTY, NEW MEXICO

LAT. : 32.390937° / LONG. : -103.89929°
 NMNM105418673 / SEC. 17-1225-30E, NESE

SITE FACILITY DIAGRAM - SHEET 1 OF 2

FILE NO. JAMES RANCH UNIT DI 11 REV. No. 3

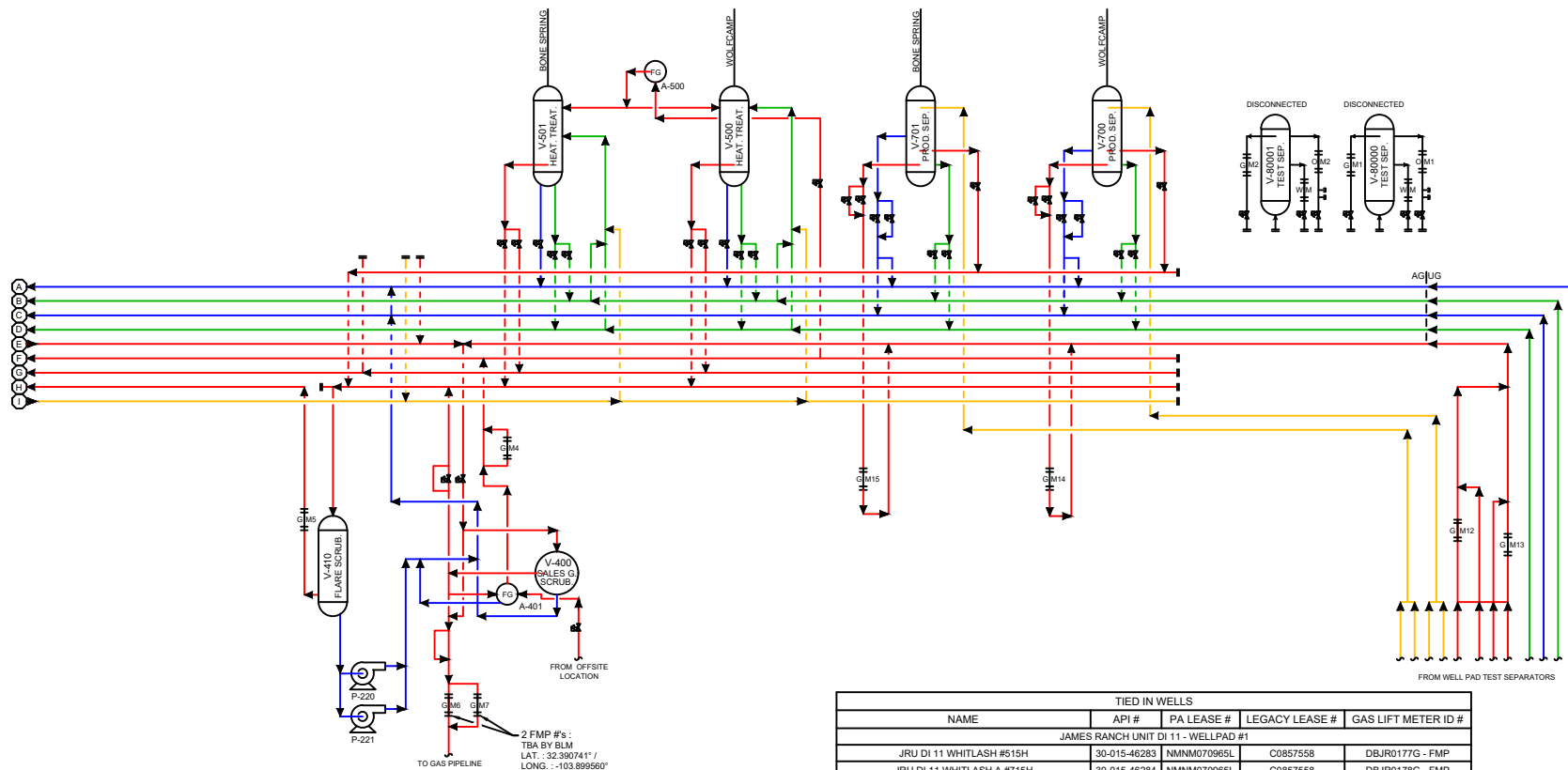
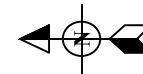

2 FMP #'s :
TBA BY GLM
LAT. : 32.390741° /
LONG. : -103.899560°

DRAWING ID	METER DESCRIPTION	TYPE	METER ID #	PURPOSE
GM1	TEST SEPARATOR V-80000 (O.O.S.)	ORIFICE	DBJR0160G	ALLOCATION
GM2	TEST SEPARATOR V-80001 (O.O.S.)	ORIFICE	DBJR0161G	ALLOCATION
GM4	FUEL GAS METER	ORIFICE	DBJR0214G	ALLOCATION
GM5	HP FLARE METER (SICK)	ULTRASONIC	DBJR0167G	PRODUCTION
GM6	10" SALES TO MSO - FMP	ORIFICE	DBJR0163G	SALES
GM7	6" SALES TO MSO - FMP	ORIFICE	DBJR0164G	SALES
GM12	10" BONE SPRING TO MSO FROM WELL PAD	ORIFICE	DBJR0249G	ALLOCATION
GM13	8" WOLFCAMP TO MSO FROM WELL PAD	ORIFICE	DBJR0250G	ALLOCATION
GM14	PRODUCTION SEPARATOR V-700	ORIFICE	DBJR0251G	PRODUCTION
GM15	PRODUCTION SEPARATOR V-701	ORIFICE	DBJR0252G	PRODUCTION

TIED IN WELLS				
NAME	API #	PA LEASE #	LEGACY LEASE #	GAS LIFT METER ID #
JAMES RANCH UNIT DI 11 - WELLPAD #1				
JRU DI 11 WHITLASH #515H	30-015-46283	NMNM070965L	C0857558	DBJR0177G - FMP
JRU DI 11 WHITLASH A #715H	30-015-46284	NMNM070965L	C0857558	DBJR0178G - FMP
JAMES RANCH UNIT DI 11 - WELLPAD #3				
JAMES RANCH UNIT DI 11 WHITLASH #251H	30-015-46377	NMNM070965L	C0857558	DBJR0193G - FMP
JAMES RANCH UNIT DI 11 - WELLPAD #7				
JAMES RANCH UNIT DI 11 EKALAKA #121H	30-015-49040	NMNM070965L	C0857558	DBJR0261G - FMP
JAMES RANCH UNIT DI 11 EKALAKA #821H	30-015-49038	NMNM070965L	C0857558	DBJR0256G - FMP
JAMES RANCH UNIT DI 11 EKALAKA U #822H	30-015-49037	NMNM070965L	C0857558	DBJR0262G - FMP
JAMES RANCH UNIT DI 11 EKALAKA #823H	30-015-49036	NMNM070965L	C0857558	DBJR0265G - FMP
JAMES RANCH UNIT DI 11 EKALAKA #921H	30-015-49039	NMNM070965L	C0857558	DBJR0257G - FMP
JAMES RANCH UNIT DI 11 - WELLPAD #8				
JAMES RANCH UNIT DI 11 EKALAKA #122H	30-015-49034	NMNM070965L	C0857558	DBJR0263G - FMP
JAMES RANCH UNIT DI 11 EKALAKA #123H	30-015-49124	NMNM070965L	C0857558	DBJR0259G - FMP
JAMES RANCH UNIT DI 11 EKALAKA #824H	30-015-49033	NMNM070965L	C0857558	DBJR0258G - FMP
JAMES RANCH UNIT DI 11 EKALAKA #922H	30-015-49035	NMNM070965L	C0857558	DBJR0260G - FMP
JAMES RANCH UNIT DI 11 EKALAKA #905H	30-015-49032	NMNM070965L	C0857558	DBJR0264G - FMP
JAMES RANCH UNIT DI 11 EKALAKA #701H	30-015-57276	--	--	-- FMP
JAMES RANCH UNIT DI 11 EKALAKA #702H	30-015-57277	--	--	-- FMP
JAMES RANCH UNIT DI 11 EKALAKA #703H	30-015-57280	--	--	-- FMP

FACILITY GAS USAGE	
ROYALTY FREE EQUIPMENT	USAGE
V-500 HEAT_TREAT.	11.8 MCFD
V-501 HEAT_TREAT.	11.8 MCFD
HP & LP FLARE PILOTS	1.2 MCFD

NOTES:
1. HEATER USAGE BASED ON MANUFACTURER'S RECOMMENDED SPECIFICATIONS.
2. FLARE PILOTS USAGE BASED ON MANUFACTURER'S RECOMMENDED SPECIFICATIONS.

EMULSION —
WATER —
OIL —
GAS —

Revision	Description of Change	Date	By	ENG APPD. By
0	AS BUILT	9/29/2022	JLF	
1	ADDED GAS METERS	8/21/2023	TDM	
2	ADDED LG. DUMP / REVISED	7/18/2025	TDM/SB	
3	ADD. NEW WELLS	2/4/2026	JLF	

JAMES RANCH UNIT DI 11
CENTRAL TANK BATTERY - VESSELS
EDDY COUNTY, NEW MEXICO

LAT. : 32.390937° , LONG. : -103.89929°
NMNM105418673 / SEC. 17-T2S-30E, NESE

SITE FACILITY DIAGRAM - SHEET 2 OF 2

FILE NO. JAMES RANCH UNIT DI 11 REV. No. 3

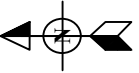

TIED IN WELLS				
METER DESCRIPTION	API #	PA LEASE #	LEGACY LEASE #	GAS LIFT METER ID #
JRU DI 11 WHITLASH #515H	30-015-46283	NMNM070965L	C0857558	DBJR0177G - FMP
JRU DI 11 WHITLASH A #715H	30-015-46284	NMNM070965L	C0857558	DBJR0178G - FMP

DRAWING ID	METER DESCRIPTION	TYPE	METER ID #	PURPOSE
GM1	WP #1 TEST SEPARATOR V-80105	ORIFICE	DBJR0236G	ALLOCATION
GM2	WP #1 TEST SEPARATOR V-80106	ORIFICE	DBJR0237G	ALLOCATION
OM1	WP #1 TEST SEPARATOR V-80105	CORIOLIS	DBJR0236O	ALLOCATION
OM2	WP #1 TEST SEPARATOR V-80106	CORIOLIS	DBJR0237O	ALLOCATION

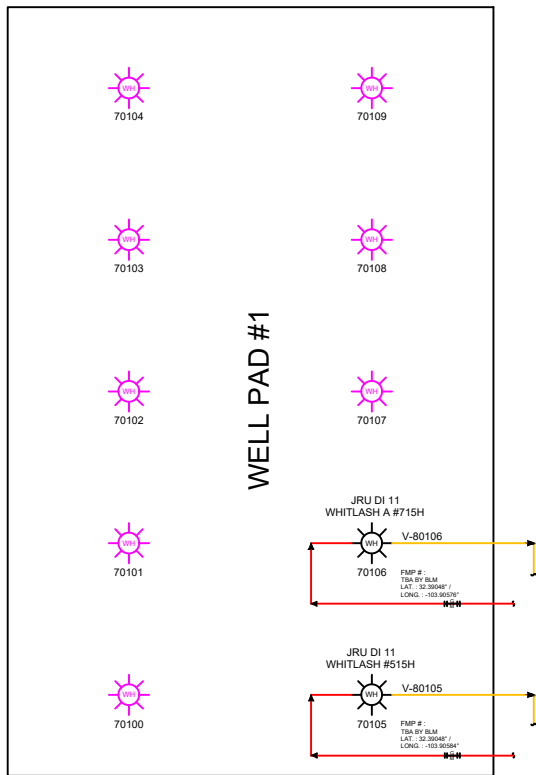

WELL PAD #1 TESTERS

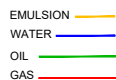
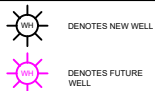
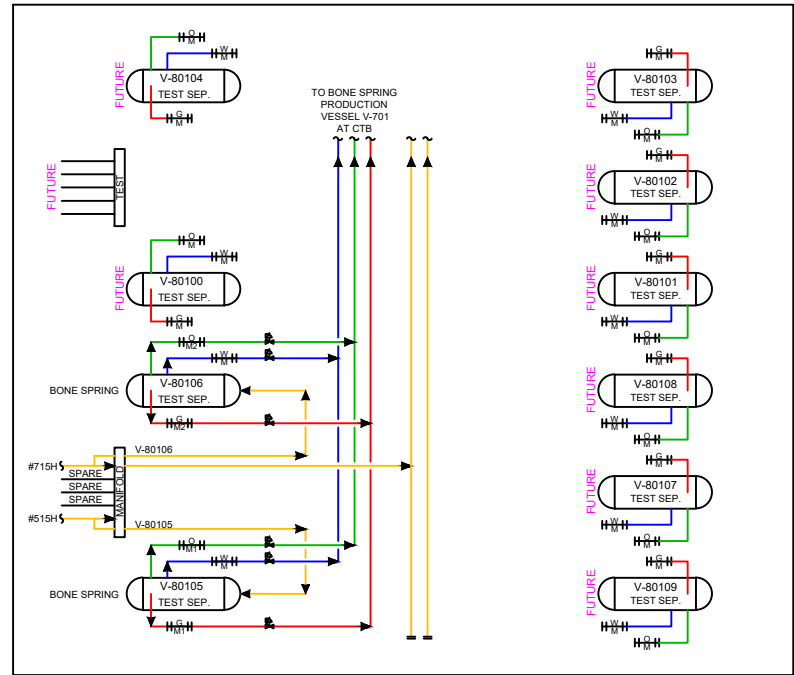

Revision	Description of Change	Date	By	ENG APPD. By
0	AS BUILT	9/29/2022	JLF	
1	ADDED GAS METERS	8/21/2023	TDM	
2	ADDED LIQ. DUMP	1/17/2024	TDM	
3	ADD. Q/L LINES & LEASE INFO	7/18/2025	SB	
4	ISSUED FOR REF.	24/2026	JLF	

JAMES RANCH UNIT DI 11 - WP #1
CENTRAL TANK BATTERY - WELL PAD LAYOUT
EDDY COUNTY, NEW MEXICO

LAT. : 32.390694°, LONG. : -103.905505°
NMNM105418673 / SEC. 17-T22S-30E, NESW
SITE FACILITY DIAGRAM - SHEET 1 OF 5

FILE NO. JAMES RANCH UNIT DI 11 REV. No. 4

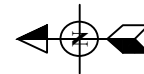

TIED IN WELLS				
METER DESCRIPTION	API #	PA LEASE #	LEGACY LEASE #	GAS LIFT METER ID #
JAMES RANCH UNIT DI 11 WHITLASH #251H	30-015-46377	NMNM070965L	C0857558	DBJR0193G - FMP

DRAWING ID	METER DESCRIPTION	TYPE	METER ID #	PURPOSE
GM1	WP #3 TEST SEPARATOR V-80309	ORIFICE	DBJR0238G	ALLOCATION
OM1	WP #3 TEST SEPARATOR V-80309	CORIOLIS	DBJR0238O	ALLOCATION

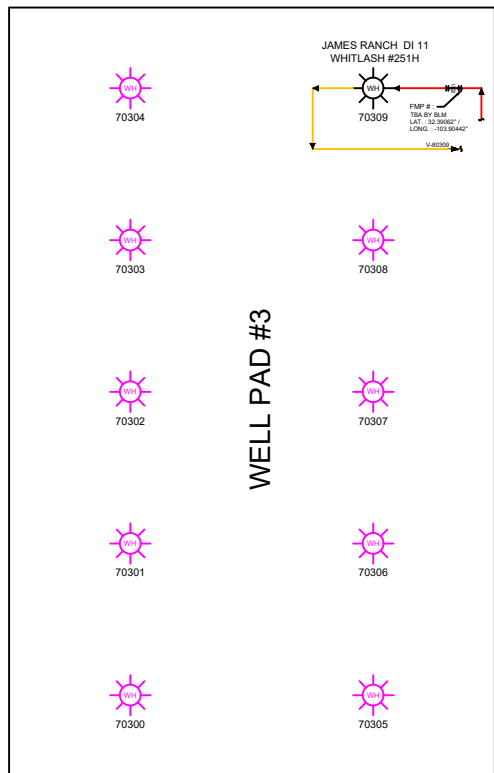

WELL PAD #3 TESTERS

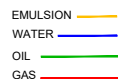
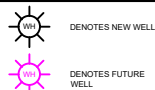
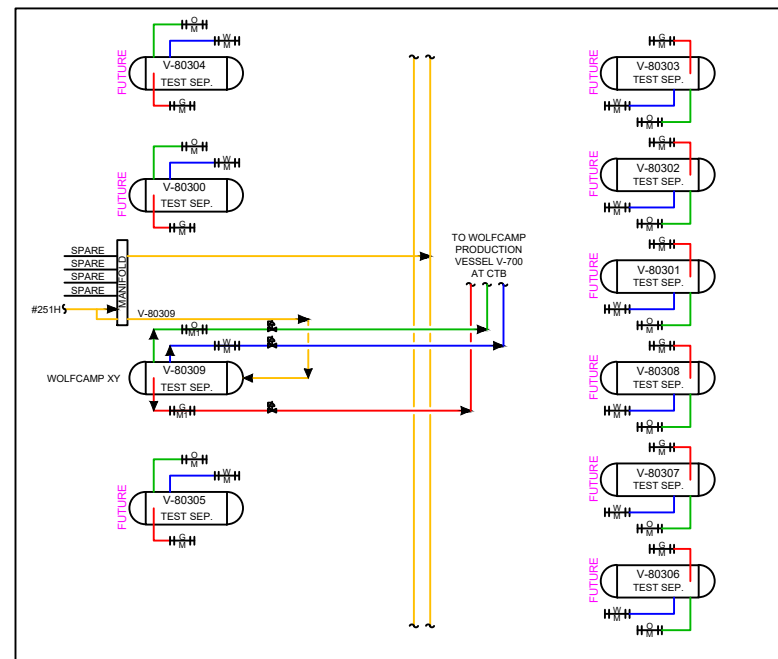

Revision	Description of Change	Date	By	ENG APPD. By
0	AS BUILT	9/28/2022	JLF	ExxonMobil
1	ADDED GAS METERS	8/21/2023	TDM	
2	ADDED LIQUID DUMP	1/17/2024	TDM	
3	ADD. GL LINES / LEASE INFO	7/18/2025	SB	
4	ISSUED FOR REF.	24/2026	JLF	

JAMES RANCH UNIT DI 11 - WP #3
CENTRAL TANK BATTERY - WELL PAD LAYOUT
EDDY COUNTY, NEW MEXICO

LAT. : 32.390686°, LONG. : -103.904237°
NMNM105418673 / SEC. 17-T22S-30E, NESW

SITE FACILITY DIAGRAM - SHEET 2 OF 5

FILE NO. JAMES RANCH UNIT DI 11 REV. No. 4

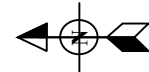

TIED IN WELLS				
METER DESCRIPTION	API #	PA LEASE #	LEGACY LEASE #	GAS LIFT METER ID #
JAMES RANCH UNIT DI 11 EKALAKA #823H	30-015-49036	NMNM070965L	C0857558	DBJR0265G - FMP
JAMES RANCH UNIT DI 11 EKALAKA U #822H	30-015-49037	NMNM070965L	C0857558	DBJR0262G - FMP
JAMES RANCH UNIT DI 11 EKALAKA #921H	30-015-49039	NMNM070965L	C0857558	DBJR0257G - FMP
JAMES RANCH UNIT DI 11 EKALAKA #821H	30-015-49038	NMNM070965L	C0857558	DBJR0256G - FMP
JAMES RANCH UNIT DI 11 EKALAKA #121H	30-015-49040	NMNM070965L	C0857558	DBJR0261G - FMP

DRAWING ID	METER DESCRIPTION	TYPE	METER ID #	PURPOSE
GM1	WP #7 TEST SEPARATOR V-80700	ORIFICE	DBJR0239G	ALLOCATION
GM2	WP #7 TEST SEPARATOR V-80701	ORIFICE	DBJR0240G	ALLOCATION
GM3	WP #7 TEST SEPARATOR V-80702	ORIFICE	DBJR0241G	ALLOCATION
GM4	WP #7 TEST SEPARATOR V-80703	ORIFICE	DBJR0242G	ALLOCATION
GM5	WP #7 TEST SEPARATOR V-80704	ORIFICE	DBJR0243G	ALLOCATION
OM1	WP #7 TEST SEPARATOR V-80700	CORIOLIS	DBJR0239O	ALLOCATION
OM2	WP #7 TEST SEPARATOR V-80701	CORIOLIS	DBJR0240O	ALLOCATION
OM3	WP #7 TEST SEPARATOR V-80702	CORIOLIS	DBJR0241O	ALLOCATION
OM4	WP #7 TEST SEPARATOR V-80703	CORIOLIS	DBJR0242O	ALLOCATION
OM5	WP #7 TEST SEPARATOR V-80704	CORIOLIS	DBJR0243O	ALLOCATION

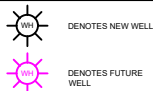
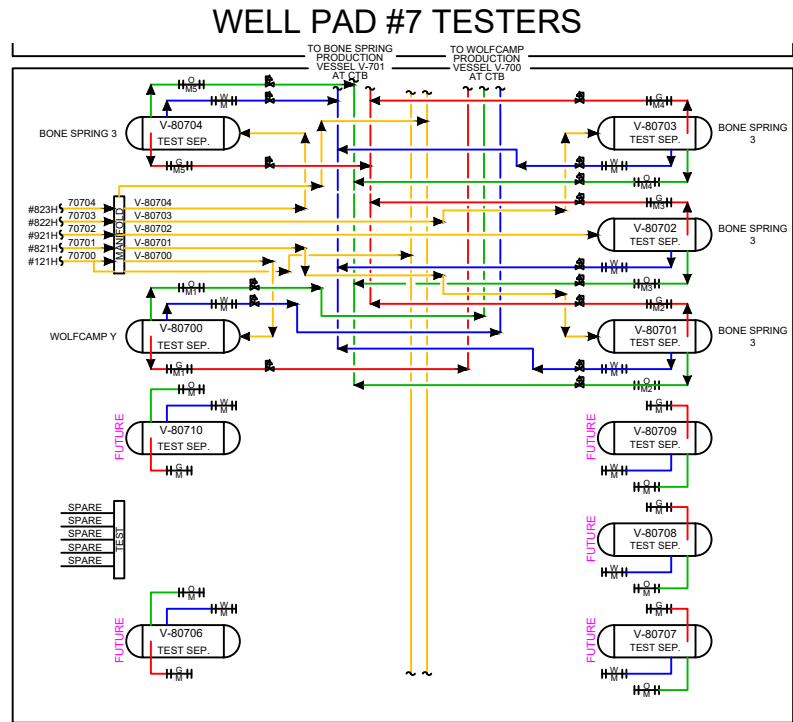
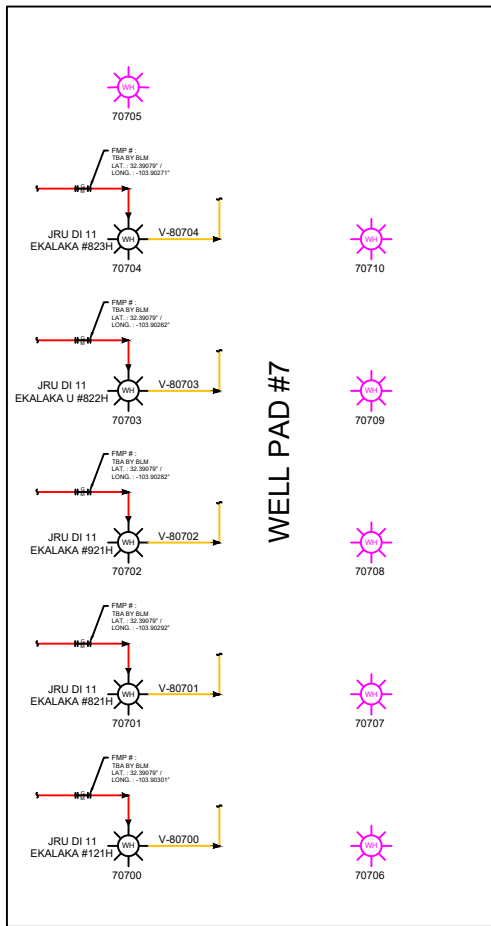

Revision	Description of Change	Date	By	ENG APPD. By	ExxonMobil
0	AS BUILT	9/28/2022	JLF		
1	ADDED GAS METERS	8/21/2023	TDM		
2	ADDED LIQUID DUMP	1/17/2024	TDM		
3	ADD. OIL LINES / LEASE INFO	7/18/2025	SB		
4	ISSUED FOR REF.	24/2026	JLF		

JAMES RANCH UNIT DI 11 - WP #7
CENTRAL TANK BATTERY - WELL PAD LAYOUT
EDDY COUNTY, NEW MEXICO

LAT. : 32.390721°, LONG. : -103.902751°
NMNM105418673 / SEC. 17-T22S-30E, NWSE
SITE FACILITY DIAGRAM - SHEET 3 OF 5

FILE NO. JAMES RANCH UNIT DI 11 REV. No. 4

DRAWING ID	METER DESCRIPTION	TYPE	METER ID #	PURPOSE
GM1	WP #8 TEST SEPARATOR V-80805	ORIFICE	DBJR0244G	ALLOCATION
GM2	WP #8 TEST SEPARATOR V-80806	ORIFICE	DBJR0245G	ALLOCATION
GM3	WP #8 TEST SEPARATOR V-80807	ORIFICE	DBJR0246G	ALLOCATION
GM4	WP #8 TEST SEPARATOR V-80808	ORIFICE	DBJR0247G	ALLOCATION
GM5	WP #8 TEST SEPARATOR V-80809	ORIFICE	DBJR0248G	ALLOCATION
GM6	WP #8 TEST SEPARATOR V-80810	ORIFICE	--	ALLOCATION
GM7	WP #8 TEST SEPARATOR V-80811	ORIFICE	--	ALLOCATION
GM8	WP #8 TEST SEPARATOR V-80812	ORIFICE	--	ALLOCATION
OM1	WP #8 TEST SEPARATOR V-80805	CORIOLIS	DBJR0244O	ALLOCATION
OM2	WP #8 TEST SEPARATOR V-80806	CORIOLIS	DBJR0245O	ALLOCATION
OM3	WP #8 TEST SEPARATOR V-80807	CORIOLIS	DBJR0246O	ALLOCATION
OM4	WP #8 TEST SEPARATOR V-80808	CORIOLIS	DBJR0247O	ALLOCATION
OM5	WP #8 TEST SEPARATOR V-80809	CORIOLIS	DBJR0248O	ALLOCATION

TIED IN WELLS				
METER DESCRIPTION	API #	PA LEASE #	LEGACY LEASE #	GAS LIFT METER ID #
JAMES RANCH UNIT DI 11 EKALAKA #122H	30-015-49034	NMNM070965L	C0857558	DBJR0263G - FMP
JAMES RANCH UNIT DI 11 EKALAKA #922H	30-015-49035	NMNM070965L	C0857558	DBJR0260G - FMP
JAMES RANCH UNIT DI 11 EKALAKA #824H	30-015-49033	NMNM070965L	C0857558	DBJR0258G - FMP
JAMES RANCH UNIT DI 11 EKALAKA #123H	30-015-49124	NMNM070965L	C0857558	DBJR0259G - FMP
JAMES RANCH UNIT DI 11 EKALAKA #905H (#923)	30-015-49032	NMNM070965L	C0857558	DBJR0264G - FMP
JAMES RANCH UNIT DI 11 EKALAKA #701H	30-015-57276	--	--	-- FMP
JAMES RANCH UNIT DI 11 EKALAKA #702H	30-015-57277	--	--	-- FMP
JAMES RANCH UNIT DI 11 EKALAKA #703H	30-015-57280	--	--	-- FMP



WELL PAD #8 TESTERS

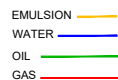
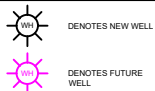
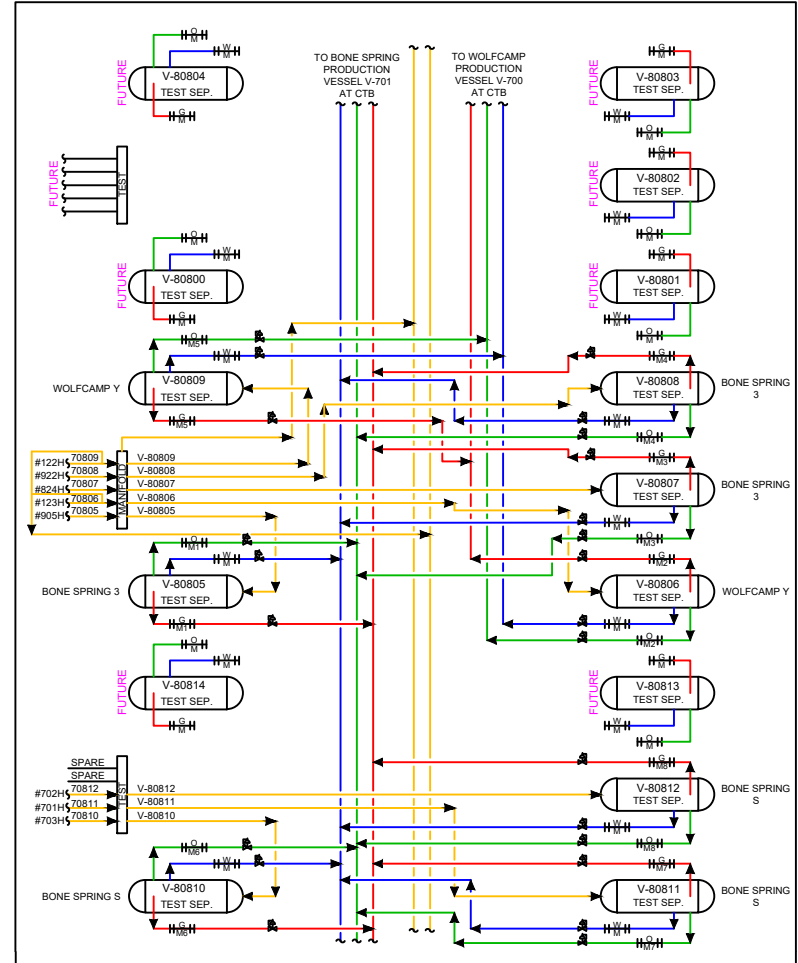
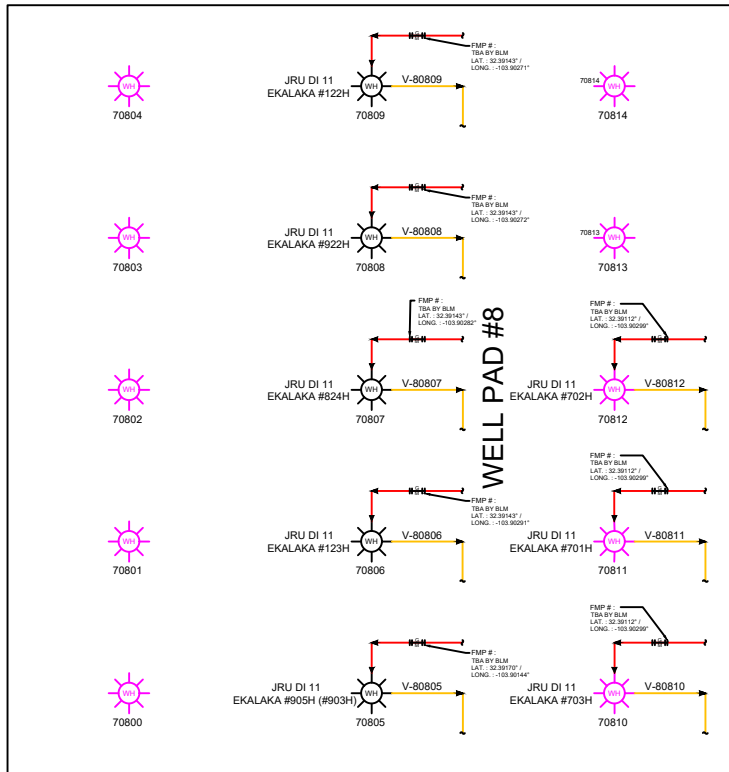

Revision	Description of Change	Date	By	ENG APPD. By
0	AS BUILT	9/29/2022	JLF	
1	ADDED GAS METERS	8/21/2023	TDM	
2	ADDED LIQUID DUMP	1/17/2024	TDM	
3	ADD GL LINES / LEASE INFO	7/18/2025	SB	
4	ADD NEW WELLS	24/2026	JLF	

JAMES RANCH UNIT DI 11 - WP #8
 CENTRAL TANK BATTERY - WELL PAD LAYOUT
 EDDY COUNTY, NEW MEXICO

LAT. : 32.391469°, LONG. : -103.902658°
 NMNM105418673 / SEC. 17-T22S-30E, NWSE

SITE FACILITY DIAGRAM - SHEET 4 OF 5

FILE NO. JAMES RANCH UNIT DI 11 REV. No. 4

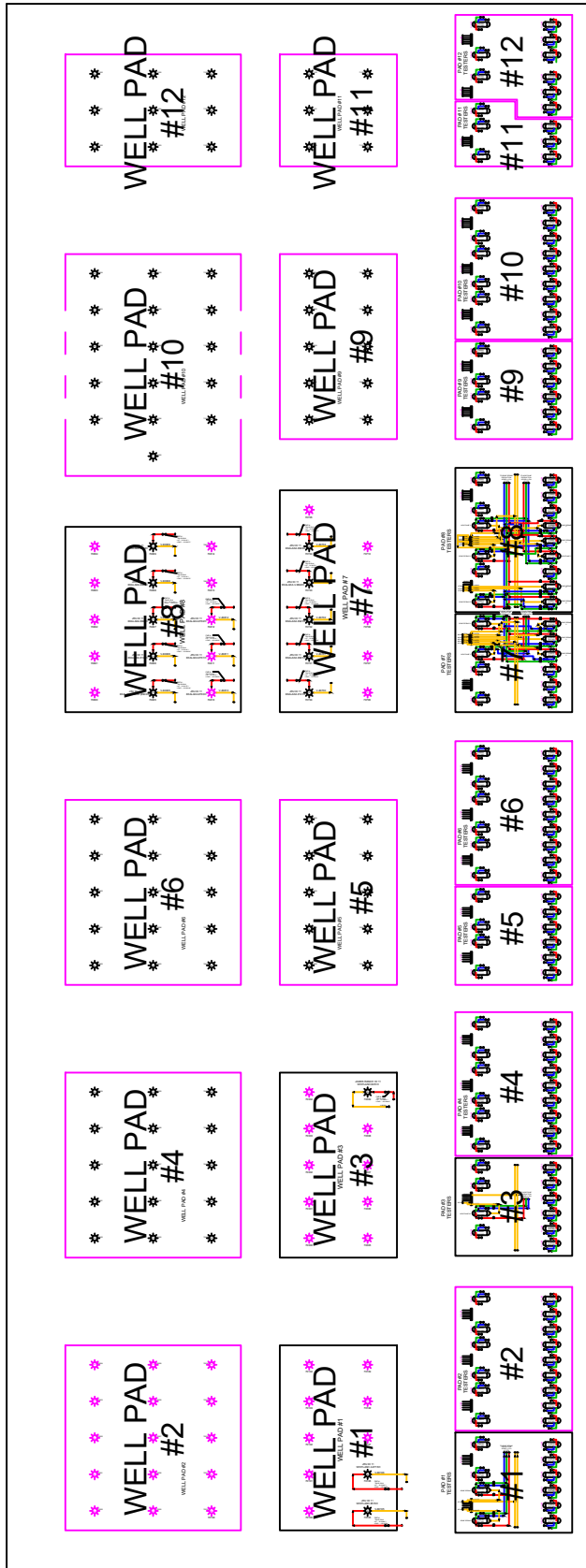
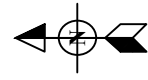

WELL PAD & TESTERS INDEX
 WELL PAD #1 & WELL PAD TESTERS - SEE SHEET 1 OF 5
 WELL PAD #3 & WELL PAD TESTERS - SEE SHEET 2 OF 5
 WELL PAD #7 & WELL PAD TESTERS - SEE SHEET 3 OF 5
 WELL PAD #8 & WELL PAD TESTERS - SEE SHEET 4 OF 5

DENOTES FUTURE WELLS

EMULSION
 WATER
 OIL
 GAS

Revision	Description of Change	Date	By	ENG. APPD. By	ExxonMobil
0	AS-BUILT	5/1/2022	JLF		
1	ADDED GAS METERS	8/21/2023	TDM		
2	ADDED LIQUID DUMP	11/17/2024	TDM		
3	ADDED GAS LIFT LINES	7/18/2025	SB		
4	ISSUED FOR REF.	2/4/2026	JLF		

JAMES RANCH UNIT DI 11 - INDEX	
CENTRAL TANK BATTERY - WELLPAD INDEX EDDY COUNTY, NEW MEXICO	
LAT.: 32.390694°, LONG.: -103.905505°	
NMNM105416673 / SEC. 17-T2S-30E, NESW	
SITE FACILITY DIAGRAM - SHEET 5 OF 5	
FILE NO.	REV. No.
JAMES RANCH UNIT DI 11	4

DRAWING REVISION LOG				
REVISION	DATE	REVISION DESCRIPTION	BY	REQUESTED BY
4	2/4/2026	ADDED NEW WELLS TO WP #8	JLF	--

32.103889, -103.802222

EMULSION ———
 WATER ———
 OIL ———
 GAS ———

Revision	Description of Change	Date	By	ENG. APPD. By	ExxonMobil
0	AS-BUILT	9/1/2022	JLF		
1	ADDED GAS METERS	8/21/2023	TDM		
2	ADDED LIQUID DUMP	11/17/2024	TDM		
3	ADDED GAS LIFT LINES	7/18/2025	SB		
4	ISSUED FOR REF.	2/4/2026	JLF		

JAMES RANCH UNIT DI 11
 CENTRAL TANK BATTERY - DRAWING LOG
 EDDY COUNTY, NEW MEXICO
 LAT.: 32.390694°, LONG.: -103.905505°
 NMNM105416673 / SEC. 17-T2S-30E, NESW
 SITE FACILITY DIAGRAM - SHEET 5 OF 5

FILE NO. **JAMES RANCH UNIT DI 11** REV. No. **0**



February 27, 2026

CERTIFIED MAIL
RETURN RECEIPT REQUESTED

TO: ALL AFFECTED PARTIES

Re: Application of XTO Permian Operating, LLC for administrative approval to surface commingle (pool and lease) oil and gas production from participating area comprised of Section 13 Township 22 South, Range 29 East and Sections 15, 16, 17 and 18 Township 22 South, Range 30 East, NMPM, Eddy County, New Mexico.

To Whom It May Concern:

Enclosed is a copy of the above-referenced application, which was filed with the New Mexico Oil Conservation Division on this date. Any objection to this application must be filed in writing within twenty (20) days from the date this application is received by the Division's Santa Fe office located at 1220 South St. Francis Drive, Santa Fe, New Mexico, 87505. If no objection is received within this twenty-day period, this application may be approved administratively by the Division.

If you have any questions about this application, please contact the following:

Russell Young
XTO Permian Operating, LLC
(832)302-5430
russell.young@exxonmobil.com

Sincerely,

Russell Young

Russell Young
New Mexico Commingle Manager
Permian Business Unit

XTO Permian Operating, LLC.
Russell Young
3617 North Big Spring Street
Midland, TX 79707
832-302-5430
Russell.young@exxonmobil.com

JRU DI 11 - POSTAL DELIVERY LIST						
RECEIPT #	NAME	ADDRESS	ADDRESS 2	STATE	ZIP	DATE SENT
94148149023689579354 43	BRODERICK JOINT REVOCABLE TRUST	1029 SW 8TH CIRCLC	LEES SUMMIT	MO	64081	3.2.26
94148149023689579354 50	CROFT LIVING TRUST KATIE ELIZABETH CROFT CO TTEE	11700 PRESTON RD STE 660 PMB 390	DALLAS	TX	75230	3.2.26
94148149023689579354 67	WEST BEND ENERGY PARTNERS LLC	1320 S UNIVERSITY DR SUITE 701	FORT WORTH	TX	76107-0000	3.2.26
94148149023689579354 74	THERESA ANN BRODERICK	1371 SW HEARTWOOD DR	LEES SUMMIT	MO	64081-0000	3.2.26
94148149023689579354 81	ROBERT E LEE HALL JR	1397 WINTER CAMP TRL	HEDGESVILLE	WV	25427-0000	3.2.26
94148149023689579354 98	SITIO PERMIAN LP	1401 LAWRENCE STREET STE 1750	DENVER	CO	80202	3.2.26
94148149023689579355 04	ROBERT CHARLES ABBOTT	14606 PAUL REVERE LN	PLAINFIELD	IL	60544	3.2.26
94148149023689579355 11	LAURA AND JOHN ARNOLD FOUNDATION	1717 WEST LOOP SOUTH SUITE 180	HOUSTON	TX	77027	3.2.26
94148149023689579355 28	JEMISON ANN MAGUIRE	1916 TUFTON CT	VIRGINIA BEACH	VA	23454	3.2.26
94148149023689579355 35	ROY G BARTON JR AND	1919 N TURNER ST	HOBBS	NM	88240-2712	3.2.26
94148149023689579355 42	KATHLEEN L GEORGE	1920 NE RICE RD	LEES SUMMIT	MO	64064	3.2.26
94148149023689579355 59	RICHARD DONALD JONES JR	200 N GAINES ROAD	CEDAR CREEK	TX	78612-0000	3.2.26
94148149023689579355 66	BRETT EVERETT LONGLEY TRUST	2002 OXFORD AVE	LUBBOCK	TX	79410-0000	3.2.26
94148149023689579355 73	WILLIAM JOSEPH LONGLEY TRUST	2002 OXFORD AVE	LUBBOCK	TX	79410-0000	3.2.26
94148149023689579355 80	2016 SAMANTHA BASS FAM TR	201 MAIN ST STE 2700	FORT WORTH	TX	76102-0000	3.2.26
94148149023689579355 97	PIVOTAL ROYALTIES PARTNERS LP	2021 MCKINNEY AVE SUITE 1250	DALLAS	TX	75201	3.2.26
94148149023689579356 03	DIANNE MARY TRUITT	20230 ATASCOCITA LAKE DR	HUMBLE	TX	77346-1659	3.2.26
94148149023689579356 10	JAMES E KAUCHER	20602 LAVERTON DR	KATY	TX	77450-0000	3.2.26
94148149023689579356 27	LINDYS LIV TR	215 W BANDERA RD STE 114 620	BOERNE	TX	78006-0000	3.2.26
94148149023689579356 34	DENICE LANELL BRODERICK	2204 NE CHIPMAN RD	LEES SUMMIT	MO	64086-1727	3.2.26
94148149023689579356 41	BUREAU OF LAND MANAGEMENT	301 DINOSAUR TRAIL	SANTA FE	NM	87501	3.2.26
94148149023689579356 58	NEW MEXICO COMMISSIONER OF NEW MEXICO STATE LAND OFFICE	310 OLD SANTA FE TRAIL	SANTA FE	NM	87501	3.2.26
94148149023689579356 65	WOODLANDS VENTURE CAPITAL COMPANY	333 W SHERIDAN AVE	OKLAHOMA CITY	OK	73102	3.2.26
94148149023689579356 72	ROBERT PETER KAUCHER	3425 FOXRIDGE DR	COLORADO SPRINGS	CO	80916-0000	3.2.26
94148149023689579356 89	RICHARD LEE HALL	3519 GLEN LOCH CT	ROCKINGHAM	VA	22801	3.2.26
94148149023689579356 96	VATEX HOLDINGS LLC	3537 W 7TH ST STE 8	FORT WORTH	TX	76107	3.2.26
94148149023689579357 02	VATEX MINERAL FUND I LP	3537 W 7TH ST STE 8	FORT WORTH	TX	76107	3.2.26
94148149023689579357 19	THE ALLEN FAMILY REV TRUST	3623 OVERBROOK DR	DALLAS	TX	75205-0000	3.2.26
94148149023689579357 26	ALLEN FAM REV TRUST DTD 05/19/00 NANCY EDGE JENNINGS ALLEN TTEE	3623 OVERBROOK DRIVE	DALLAS	TX	75205	3.2.26
94148149023689579357 33	PUMA MINERAL PARTNERS LLC	3811 TURTLE CREEK BLVD SUITE 1	DALLAS	TX	75219	3.2.26
94148149023689579357 40	SMP TITAN FLEX LP	4143 MAPLE AVE SUITE 500	DALLAS	TX	75219	3.2.26
94148149023689579357 57	MSH FAM REAL EST PRNTNSP II LLC	4143 MAPLE AVE SUITE 500	DALLAS	TX	75219	3.2.26
94148149023689579357 64	SMP PATRIOT MINERAL HOLDINGS LLC	4143 MAPLE AVE SUITE 500	DALLAS	TX	75219	3.2.26
94148149023689579357 71	SMP SIDECAR TITAN	4143 MAPLE AVENUE STE 500	DALLAS	TX	75219	3.2.26
94148149023689579357 88	SMP TITAN MINERAL	4143 MAPLE AVENUE STE 500	DALLAS	TX	75219	3.2.26
94148149023689579357 95	ROSS BRODERICK	4285 SE 1147 RD	OSCEOLA	MO	64776-6259	3.2.26
94148149023689579358 01	WRS ENTERPRISES INC	5214 YOLANDA LANE	DALLAS	TX	75229	3.2.26
94148149023689579358 18	CONOCOPHILLIPS COMPANY	600 W ILLINOIS AVE	MIDLAND	TX	79701	3.2.26
94148149023689579358 25	JAVELINA PRTRNS	616 TEXAS ST	FORT WORTH	TX	76102-0000	3.2.26
94148149023689579358 32	ZORRO PARTNERS LTD	616 TEXAS ST	FORT WORTH	TX	76102-0000	3.2.26
94148149023689579358 49	ADRIAN LYNN DAWE	710 CHRISTOPHER	PLEASANT HILL	MO	64080-0000	3.2.26
94148149023689579358 56	PATSY MILLS BAKER GST TRUST	901 W 8TH ST	IDALOU	TX	79329-0000	3.2.26
94148149023689579358 63	PATSY MILLS BAKER 2005 GST TR	901 W 8TH ST	IDALOU	TX	79329-0000	3.2.26
94148149023689579358 70	JIMMY MILLS GST TRUST	9210 YORK PLACE	LUBBOCK	TX	79424	3.2.26
94148149023689579358 87	JIMMY MILLS 2005 GST TRUST	9210 YORK PLACE	LUBBOCK	TX	79424	3.2.26
94148149023689579358 94	RICHARD WARD KAUCHER	9597 JONES RD PMB 302	HOUSTON	TX	77065-0000	3.2.26
94148149023689579359 00	ARD OIL LTD	PO BOX 101027	FORT WORTH	TX	76185-0000	3.2.26
94148149023689579359 17	PATRICIA BOYLE YOUNG MGMT TRST ATTN BRANDON LONG	PO BOX 1037	OKMULGEE	OK	74447-0000	3.2.26
94148149023689579359 24	ELLIOTT INDUSTRIES LP	PO BOX 1328	SANTA FE	NM	87504-0000	3.2.26
94148149023689579359 31	ELLIOTT HALL COMPANY	PO BOX 1328	SANTA FE	NM	87504	3.2.26
94148149023689579359 48	NICHOLAS CLAY ANDERSON	PO BOX 1342	SABINAL	TX	78881-0000	3.2.26
94148149023689579359 55	BALONEY FEATHERS LTD	PO BOX 1586	LUBBOCK	TX	79408-0000	3.2.26
94148149023689579359 62	JOSEPHINE T HUDSON TEST TR	PO BOX 1600	SAN ANTONIO	TX	78296-0000	3.2.26
94148149023689579359 79	JENNINGS LEE TRUST	PO BOX 20204	HOT SPRINGS	AR	71903-0204	3.2.26
94148149023689579359 86	SLAYTON INVESTMENT LLC	PO BOX 2035	ROSWELL	NM	88202-2035	3.2.26
94148149023689579359 93	ROLLA R HINKLE III	PO BOX 2292	ROSWELL	NM	88202-2292	3.2.26
94148149023689579360 06	PENASCO PETROLEUM LLC	PO BOX 2292	ROSWELL	NM	88202-2292	3.2.26
94148149023689579360 13	MCMULLEN MINERALS LLC	PO BOX 470857	FORT WORTH	TX	76147-0000	3.2.26
94148149023689579360 20	JOHN & THERESA HILLMAN FAMILY	PO BOX 50187	MIDLAND	TX	79710-0187	3.2.26
94148149023689579360 37	MARSHALL AND WINSTON INC	PO BOX 50880	MIDLAND	TX	79710-0880	3.2.26
94148149023689579360 44	HORTON ROYALTY LP	PO BOX 50938	MIDLAND	TX	79710	3.2.26
94148149023689579360 51	DUNCAN MANAGEMENT LLC AGENT	PO BOX 671099	DALLAS	TX	75367-1099	3.2.26
94148149023689579360 68	PEGASUS RESOURCES II LLC	PO BOX 731077	DALLAS	TX	75373-1077	3.2.26
94148149023689579360 75	PEGASUS RESOURCES LLC	PO BOX 733980	DALLAS	TX	75373-3980	3.2.26
94148149023689579360 82	DELMAR HUDSON LEWIS LIV TRUST	PO BOX 840738	DALLAS	TX	75284-0738	3.2.26
94148149023689579360 99	CTAM O&G LLC	PO BOX 99084	FORT WORTH	TX	76199	3.2.26
94148149023689579361 05	GC O&G LLC	PO BOX 99084	FORT WORTH	TX	76199	3.2.26
UNKNOWN	DEBLOIS REV TR DTD 07/16/2008	UNKNOWN	DELAWARE	DE	19801-0000	UNKNOWN

Affidavit of Publication

Copy of Publication:

No. 87060

State of New Mexico

County of Eddy:

Adrian Hedden

being duly sworn, says that he is the Publisher

of the Carlsbad Current Argus, a weekly newspaper of general circulation, published in English at Carlsbad, said county and state, and that the hereto attached

Legal Ad

was published in a regular and entire issue of the said Carlsbad Current Argus, a weekly newspaper duly qualified for that purpose within the meaning of Chapter 167 of the 1937 Session Laws of the state of New Mexico for 1 Consecutive weeks/day on the same

day as follows:

- First Publication March 5, 2026
- Second Publication _____
- Third Publication _____
- Fourth Publication _____
- Fifth Publication _____
- Sixth Publication _____
- Seventh Publication _____
- Eighth Publication _____

Subscribed and sworn before me this

5th day of March 2026

LATISHA ROMINE
 Notary Public, State of New Mexico
 Commission No. 1076338
 My Commission Expires
 05-12-2027

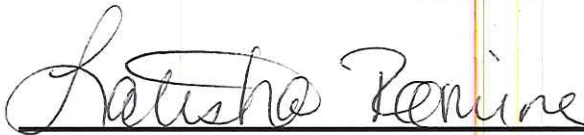

Latisha Romine
Notary Public, Eddy County, New Mexico

TO: ALL AFFECTED PARTIES, INCLUDING: BRODERICK JOINT REVOCABLE TRUST CROFT LIVING TRUST KATIE ELIZABETH CROFT CO TTEE WEST BEND ENERGY PARTNERS LLC THERESA ANN BRODERICK ROBERT E LEE HALL JR SITE PERMIAN LP ROBERT CHARLES ABBOTT LAURA AND JOHN ARNOLD FOUNDATION JEMISON ANN MAGUIRE ROY G BARTON JR AND KATHLEEN L GEORGE RICHARD DONALD JONES JR BRETT EVERETT LONGLEY TRUST WILLIAM JOSEPH LONGLEY TRUST 2016 SAMANTHA BASS FAM TR PIVOTAL ROYALTIES PARTNERS LP DIANNE MARY TRUITT JAMES E KAUCHER LINDYS LIV TR DENICE LANELL BRODERICK BUREAU OF LAND MANAGEMENT NEW MEXICO COMMISSIONER OF NEW MEXICO STATE LAND OFFICE WOODLANDS VENTURE CAPITAL COMPANY ROBERT PETER KAUCHER RICHARD LEE HALL VATEX HOLDINGS LLC VATEX MINERAL FUND I LP THE ALLEN FAMILY REV TRUST ALLEN FAM REV TRUST DTD 05/19/00 NANCY EDGE JENNINGS ALLEN TTEE PUMA MINERAL PARTNERS LLC SMP TITAN FLEX LP MSH FAM REAL EST PRINSP II LLC SMP PATRIOT MINERAL HOLDINGS LLC SMP SIDECAR TITAN SMP TITAN MINERAL ROSS BRODERICK WRS ENTERPRISES INC CONOCOPHILLIPS COMPANY JAVELINA PRTRNSZORRO PARTNERS LTD ADRIAN LYNN DAWEPATSY MILLS BAKER GST TRUST PATSY MILLS BAKER 2005 GST TR JIMMY MILLS GST TRUST JIMMY MILLS 2005 GST TRUST RICHARD WARD KAUCHER ARD OIL LTD PATRICIA BOYLE YOUNG MGMT TRST ATTN: BRANDON LONG ELLIOTT INDUSTRIES LP ELLIOTT HALL COMPANY NICHOLAS CLAY ANDERSON BALONEY FEATHERS LTD JOSEPHINE T HUDSON TEST TR JENNINGS LEE TRUST SLAYTON INVESTMENT LLC ROLLA R HINKLE III PENASCO PETROLEUM LLC MCMULLEN MINERALS LLC JOHN & THERESA HILLMAN FAMILY MARSHALL AND WINSTON INC HORTON ROYALTY LP DUNCAN MANAGEMENT LLC AGENT PEGASUS RESOURCES II LLC PEGASUS RESOURCES LLC DELMAR HUDSON LEWIS LIV TRUST CTAM O&G LLC GC O&G LLC

Application of XTO Permian Operating, LLC for administrative approval to surface commingle (pool and lease) oil and gas production from participating area comprised of Section 13 Township 22 South, Range 29 East and Sections 15, 16, 17 and 18 Township 22 South, Range 30 East, NMPM, Eddy County, New Mexico.

XTO Permian Operating, LLC (OGRID No. 373075) (XTO), pursuant to 19.15.12.10 NMAC, seeks administrative approval to surface commingle (on lease) diversely owned oil and gas production at the James Ranch Unit DI 11 Central Tank Battery (CTB) insofar as all existing and future wells drilled in the following spacing units:

(a) The 10,613.77 acres, of Participating Area NMNM 070965O comprised of N/2 S/2 Section 13 of Township 22S Range 29E; S/2 SW/4 Section 14; All Section 15; All Section 16; SW/4, E/2 Section 17; Lot 3-4, E/2 SW/4, SE/4 (ada: S/2) Section 18; Lots 1-4, E/2 W/2, E/2 (ada: All) Section 19; All Section 20; All Section 21; All Section 22; W/2, S/2, SE/4 Section 23; S/2 S/2 Section 24; All Section 26; All Section 27; E/2 Section 28; N/2 NE/4, NE/4 NW/4, Section 35; N/2 NW/4, SE/4 NW/4, N/2 SW/4, SE/4 SW/4, E/2 Section 36; of Township 22S Range 30E; Lots 1-4, E/2 W/2, E/2 (ada:All) Section 31 of Township 22S Range 31E; Lot 4, SW/4 NW/4, W/2 SW/4 (ada: W/2 W/2) Section 5; Lot 1-7, SE/4 NW/4, E/2 SW/4, S/2 NE/4, SE/4 (ada: All) Section 6; Lot 1-4, E/2 W/2, E/2 (ada: ALL) Section 7; W/2 Section 8; NW/4 Section 17; Lot 1-2, E/2 NW/4, NE/4 (ada: N/2) Section 18 of Township 23S Range 31E; in the [97905] WILDCAT G-07 S223021G; BONE SPRING currently dedicated to the following wells:

- 3001549038 JAMES RANCH UNIT DI 11 EKALAKA 821H
- 3001549037 JAMES RANCH UNIT DI 11 EKALAKA
- U 823001549036 JAMES RANCH UNIT DI 11 EKALAKA 823H
- 3001549033 JAMES RANCH UNIT DI 11 EKALAKA 824H
- 3001549032 JAMES RANCH UNIT DI 11 EKALAKA 923H
- 3001549039 JAMES RANCH UNIT DI 11 EKALAKA 921H
- 3001549035 JAMES RANCH UNIT DI 11 EKALAKA 922H
- 3001557276 JAMES RANCH UNIT DI 11 EKALAKA 701H
- 3001557277 JAMES RANCH UNIT DI 11 EKALAKA 702H
- 3001557280 JAMES RANCH UNIT DI 11 EKALAKA 703H
- 3001546284 JAMES RANCH UNIT DI 11 WHITLASHA 715H

(b) The 10,373.77 acres, of Participating Area NMNM 070965L comprised of N/2 S/2 Section 13 of Township 22S Range 29E; All Section 15; All Section 16; SW/4, E/2 Section 17; Lot 3-4, E/2 SW/4, SE/4 (ada: S/2) Section 18; Lots 1-4, E/2 W/2, E/2 (ada: All) Section 19; All Section 20; All Section 21; All Section 22; W/2 Section 23; All Section 26; All Section 27; E/2 Section 28;

N/2 NE/4, NE/4 NW/4, S/2 SE/4 Section 35; N/2 NW/4, SE/4 NW/4, NE/4 SW/4, S/2 SW/4, E/2 Section 36; of Township 22S Range 30E; Lots 1-4, E/2 W/2, E/2 (ada:All) Section 31 of Township 22S Range 31E; Lot 4, SW/4 NW/4, W/2 SW/4 (ada: W/2 W/2) Section 5; Lot 1-7, SE/4 NW/4, E/2 SW/4, S/2 NE/4, SE/4 (ada: All) Section 6; Lot 1-4, E/2 W/2, E/2 (ada: ALL) Section 7; W/2 Section 8; NW/4 Section 17; Lot 1-2, E/2 NW/4, NE/4 (ada: N/2) Section 18 of Township 23S Range 31E; in the [96336] LOS MEDANOS; WOLFCAMP, SOUTH; [96597] LOS MEDANOS; WOLFCAMP (GAS); AND [98344] WC 015 G08 S223017 K WOLFCAMP currently dedicated to the following wells:

- 3001549040 JAMES RANCH UNIT DI 11 EKALAKA 121H
- 3001546283 JAMES RANCH UNIT DI 11 WHITLASH 515H
- 3001549034 JAMES RANCH UNIT DI 11 EKALAKA 122H
- 3001549124 JAMES RANCH UNIT DI 11 EKALAKA 123H
- 3001546377 JAMES RANCH UNIT DI 11 WHITLASH 251H

Pursuant to 19.15.12.10.C(4)(g), from all future additions of pools, leases or leases and pools to the James Ranch Unit DI 11 Central Tank Battery (CTB) with notice provided only to the owners of interests to be added

Any objection to this application must be filed in writing within twenty (20) days from the date of publication with the New Mexico Oil Conservation Division, 1220 South St. Francis Drive, Santa Fe, New Mexico, 87505. If no objection is received within this twenty-day period, this application may be approved administratively by the Division. If you have any questions about this application, please contact Russell Young, XTO Energy, Inc., (832)-454-2857 or Russell.young@exxonmobil.com. 87060-Published in Carlsbad Current Argus March 5, 2026.

Help



Product Tracking & Reporting

Home

Search

Reports

Manual Entry

Rates/
Commitments

PTR / EDW

Customer
Information

April 09, 2026

USPS Tracking Intranet

Delivery Signature and Address



1. Do not share information from this site outside of USPS. It is intended for USPS employee use only.
2. Employees may see some items with only event MT in the tracking record. This is an indication that the tracking number was part of problem where the USPS Label Creation API created the same label number multiple times. This led to a confusing tracking experience, so tracking has been suppressed. Reference this ticket for more info: INC000010539853.

Tracking Number: 9414 8149 0236 8957 9354 43

This item was delivered on 03/11/2026 at 13:07:00

[< Return to Tracking Number View](#)

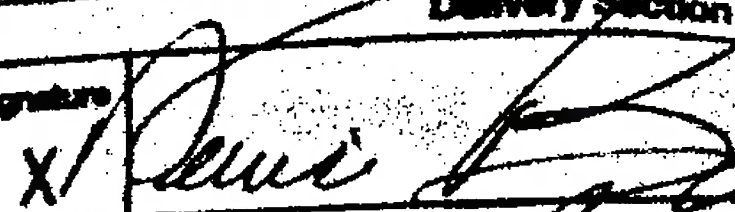
Delivery Section	
Signature	<p>Signature</p> 
Printed Name	<p>Printed Name</p> <p>DENISE BRADEN</p>
Address	<p>Delivery Address</p> <p>1029 SW 8th Circle</p>

Enter up to 35 items separated by commas.

Select Search Type:

Quick Search ▼

Submit

Product Tracking & Reporting, All Rights Reserved

Version: 26.2.1-9f61da1e

Help



Product Tracking & Reporting

Home

Search

Reports

Manual Entry

Rates/
Commitments

PTR / EDW

Customer
Information

April 09 2026

USPS Tracking Intranet

Delivery Signature and Address



- 1. Do not share information from this site outside of USPS. It is intended for USPS employee use only.
- 2. Employees may see some items with only event MT in the tracking record. This is an indication that the tracking number was part of problem where the USPS Label Creation API created the same label number multiple times. This led to a confusing tracking experience, so tracking has been suppressed. Reference this ticket for more info: INC000010539853.

Tracking Number: 9414 8149 0236 8957 9354 50

This item was delivered on 03/12/2026 at 16:45:00

[Return to Tracking Number View](#)

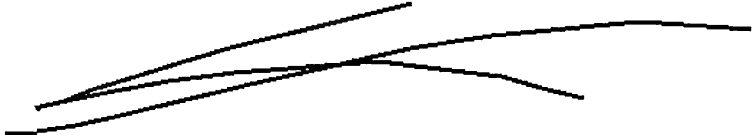
Signature	
Address	

Enter up to 35 items separated by commas.

Select Search Type:

Quick Search



Submit

Product Tracking & Reporting, All Rights Reserved
Version: 26.2.1-9f61da1e

[Help](#)



Product Tracking & Reporting

[Home](#)

[Search](#)

[Reports](#)

[Manual Entry](#)

[Rates/
Commitments](#)

[PTR / EDW](#)

[Customer
Information](#)

April 09, 2026

USPS Tracking Intranet

Delivery Signature and Address



- 1. Do not share information from this site outside of USPS. It is intended for USPS employee use only.
- 2. Employees may see some items with only event MT in the tracking record. This is an indication that the tracking number was part of problem where the USPS Label Creation API created the same label number multiple times. This led to a confusing tracking experience, so tracking has been suppressed. Reference this ticket for more info: INC000010539853.

Tracking Number: 9414 8149 0236 8957 9354 67

This item was delivered on 03/09/2026 at 15:51:00

[< Return to Tracking Number View](#)

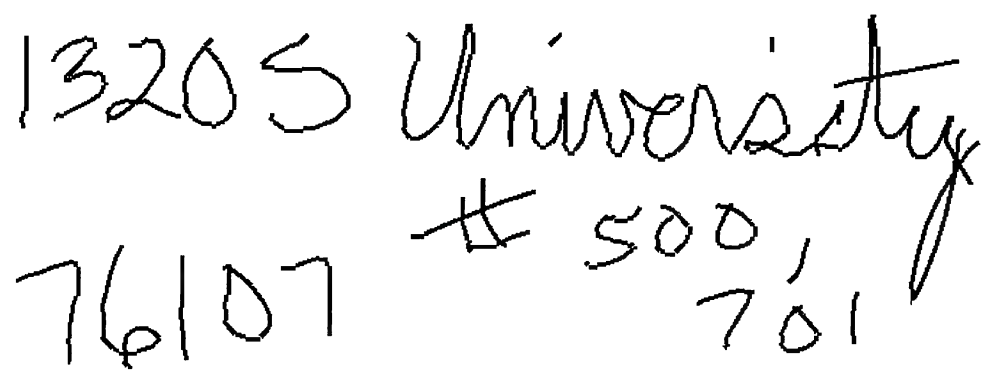
Signature	
Address	

Enter up to 35 items separated by commas.

Select Search Type:

Quick Search

Product Tracking & Reporting, All Rights Reserved
Version: 26.2.1-9f61da1e

[Help](#)



Product Tracking & Reporting

[Home](#)

[Search](#)

[Reports](#)

[Manual Entry](#)

[Rates/
Commitments](#)

[PTR / EDW](#)

[Customer
Information](#)

April 09, 2026

USPS Tracking Intranet

Delivery Signature and Address



1. Do not share information from this site outside of USPS. It is intended for USPS employee use only.
2. Employees may see some items with only event MT in the tracking record. This is an indication that the tracking number was part of problem where the USPS Label Creation API created the same label number multiple times. This led to a confusing tracking experience, so tracking has been suppressed. Reference this ticket for more info: INC000010539853.

Tracking Number: 9414 8149 0236 8957 9354 74

This item was delivered on 03/09/2026 at 18:46:00

[< Return to Tracking Number View](#)

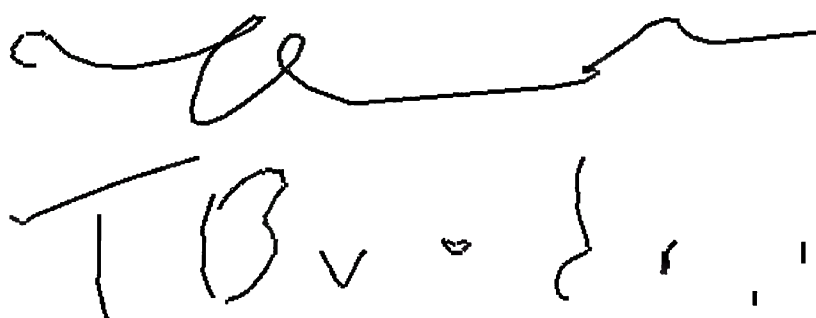
Signature	
Address	<p>1371 SW HEARTWOOD DR, LEES SUMMIT, MO 64081</p>

Enter up to 35 items separated by commas.

Select Search Type:

Quick Search



Submit

Product Tracking & Reporting, All Rights Reserved
Version: 26.2.1-9f61da1e

[Help](#)



Product Tracking & Reporting

[Home](#)

[Search](#)

[Reports](#)

[Manual Entry](#)

[Rates/
Commitments](#)

[PTR / EDW](#)

[Customer
Information](#)

April 09 2026

USPS Tracking Intranet

Delivery Signature and Address



1. Do not share information from this site outside of USPS. It is intended for USPS employee use only.
2. Employees may see some items with only event MT in the tracking record. This is an indication that the tracking number was part of problem where the USPS Label Creation API created the same label number multiple times. This led to a confusing tracking experience, so tracking has been suppressed. Reference this ticket for more info: INC000010539853.

Tracking Number: 9414 8149 0236 8957 9354 81

This item was delivered on 03/09/2026 at 13:41:00

[< Return to Tracking Number View](#)

Signature	
Address	<p>1397 WINTER CAMP TRL</p> <p>HEDGESVILLE, WV 25427-5361</p>

Enter up to 35 items separated by commas.

Select Search Type:

Quick Search



Submit

Product Tracking & Reporting, All Rights Reserved

Version: 26.2.1-9f61da1e

[Help](#)



Product Tracking & Reporting

[Home](#)

[Search](#)

[Reports](#)

[Manual Entry](#)

[Rates/
Commitments](#)

[PTR / EDW](#)

[Customer
Information](#)

April 09 2026

USPS Tracking Intranet

Delivery Signature and Address



1. Do not share information from this site outside of USPS. It is intended for USPS employee use only.
2. Employees may see some items with only event MT in the tracking record. This is an indication that the tracking number was part of problem where the USPS Label Creation API created the same label number multiple times. This led to a confusing tracking experience, so tracking has been suppressed. Reference this ticket for more info: INC000010539853.

Tracking Number: 9414 8149 0236 8957 9354 81

This item was delivered on 03/09/2026 at 13:41:00

[< Return to Tracking Number View](#)

Signature	
Address	<p>1397 WINTER CAMP TRL</p> <p>HEDGESVILLE, WV 25427-5361</p>

Enter up to 35 items separated by commas.

Select Search Type:

Quick Search



Submit

Product Tracking & Reporting, All Rights Reserved
Version: 26.2.1-9f61da1e

[Help](#)



Product Tracking & Reporting

[Home](#)

[Search](#)

[Reports](#)

[Manual Entry](#)

[Rates/
Commitments](#)

[PTR / EDW](#)

[Customer
Information](#)

April 09, 2026

USPS Tracking Intranet

Delivery Signature and Address



- 1. Do not share information from this site outside of USPS. It is intended for USPS employee use only.
- 2. Employees may see some items with only event MT in the tracking record. This is an indication that the tracking number was part of problem where the USPS Label Creation API created the same label number multiple times. This led to a confusing tracking experience, so tracking has been suppressed. Reference this ticket for more info: INC000010539853.

Tracking Number: 9414 8149 0236 8957 9354 98

This item was delivered on 03/24/2026 at 08:28:00

[< Return to Tracking Number View](#)

Delivery Section					
Signature	<table border="1"> <tr> <td>Signature</td> <td>X</td> </tr> <tr> <td>Printed Name</td> <td>W. Berry</td> </tr> </table>	Signature	X	Printed Name	W. Berry
Signature	X				
Printed Name	W. Berry				
Address	<table border="1"> <tr> <td>Delivery Address</td> <td>5505 Alameda St *</td> </tr> </table>	Delivery Address	5505 Alameda St *		
Delivery Address	5505 Alameda St *				

Enter up to 35 items separated by commas.

Select Search Type:

Quick Search

Product Tracking & Reporting, All Rights Reserved

Version: 26.2.1-9f61da1e

[Help](#)



Product Tracking & Reporting

[Home](#)

[Search](#)

[Reports](#)

[Manual Entry](#)

[Rates/
Commitments](#)

[PTR / EDW](#)

[Customer
Information](#)

Apr 09 2026

USPS Tracking Intranet

Delivery Signature and Address



1. Do not share information from this site outside of USPS. It is intended for USPS employee use only.
2. Employees may see some items with only event MT in the tracking record. This is an indication that the tracking number was part of problem where the USPS Label Creation API created the same label number multiple times. This led to a confusing tracking experience, so tracking has been suppressed. Reference this ticket for more info: INC000010539853.

Tracking Number: 9414 8149 0236 8957 9355 04

This item was delivered on 03/10/2026 at 14:45:00

[< Return to Tracking Number View](#)

Signature	Signature X	
	Printed Name	
Address	Delivery Address	

Enter up to 35 items separated by commas.

Select Search Type:

Quick Search



Submit

Product Tracking & Reporting, All Rights Reserved

Version: 26.2.1-9f61da1e

[Help](#)



Product Tracking & Reporting

[Home](#)

[Search](#)

[Reports](#)

[Manual Entry](#)

[Rates/
Commitments](#)

[PTR / EDW](#)

[Customer
Information](#)

April 09, 2026

USPS Tracking Intranet

Delivery Signature and Address



1. Do not share information from this site outside of USPS. It is intended for USPS employee use only.

2. Employees may see some items with only event MT in the tracking record. This is an indication that the tracking number was part of problem where the USPS Label Creation API created the same label number multiple times. This led to a confusing tracking experience, so tracking has been suppressed. Reference this ticket for more info: INC000010539853.

Tracking Number: 9414 8149 0236 8957 9355 11

This item was delivered on 03/09/2026 at 15:32:00

[< Return to Tracking Number View](#)

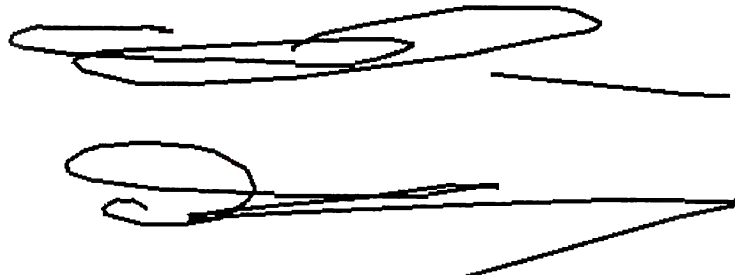
Signature	
Address	<p>771 7th Loop, A1800</p>

Enter up to 35 items separated by commas.

Select Search Type:

Quick Search



Submit

Product Tracking & Reporting, All Rights Reserved

Version: 26.2.1-9f61da1e

[Help](#)



Product Tracking & Reporting

[Home](#)

[Search](#)

[Reports](#)

[Manual Entry](#)

[Rates/
Commitments](#)

[PTR / EDW](#)

[Customer
Information](#)

April 03, 2026

USPS Tracking Intranet

Delivery Signature and Address



1. Do not share information from this site outside of USPS. It is intended for USPS employee use only.
2. Employees may see some items with only event MT in the tracking record. This is an indication that the tracking number was part of problem where the USPS Label Creation API created the same label number multiple times. This led to a confusing tracking experience, so tracking has been suppressed. Reference this ticket for more info: INC000010539853.

Tracking Number: 9414 8149 0236 8957 9355 28

This item was delivered on 03/07/2026 at 11:33:00

[< Return to Tracking Number View](#)

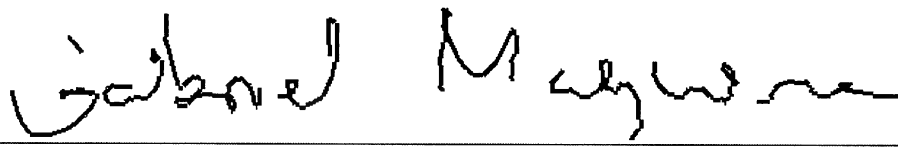
Signature	 
Address	<p>1916 TUFTON CT, VIRGINIA BEACH, VA 23454</p>

Enter up to 35 items separated by commas.

Select Search Type:

Quick Search

Product Tracking & Reporting, All Rights Reserved
Version: 26.2.1-9f61da1e

[Help](#)



Product Tracking & Reporting

[Home](#)

[Search](#)

[Reports](#)

[Manual Entry](#)

[Rates/
Commitments](#)

[PTR / EDW](#)

[Customer
Information](#)

April 09, 2026

USPS Tracking Intranet

Delivery Signature and Address





1. Do not share information from this site outside of USPS. It is intended for USPS employee use only.
2. Employees may see some items with only event MT in the tracking record. This is an indication that the tracking number was part of problem where the USPS Label Creation API created the same label number multiple times. This led to a confusing tracking experience, so tracking has been suppressed. Reference this ticket for more info: INC000010539853.

Tracking Number: 9414 8149 0236 8957 9355 35

This item was delivered on 03/06/2026 at 11:00:00

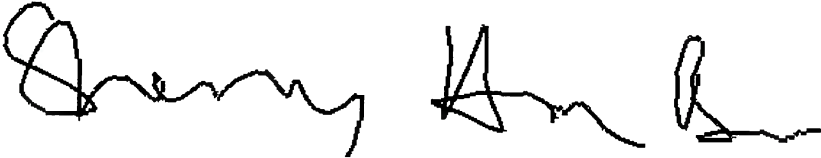
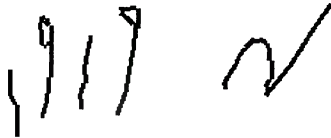
[< Return to Tracking Number View](#)

Signature	 
Address	 

Enter up to 35 items separated by commas.

Select Search Type:

Quick Search

Product Tracking & Reporting, All Rights Reserved
Version: 26.2.1-9f61da1e

[Help](#)



Product Tracking & Reporting

[Home](#)

[Search](#)

[Reports](#)

[Manual Entry](#)

[Rates/
Commitments](#)

[PTR / EDW](#)

[Customer
Information](#)

April 09, 2026

USPS Tracking Intranet Tracking Number Result



1. Do not share information from this site outside of USPS. It is intended for USPS employee use only.
2. Employees may see some items with only event MT in the tracking record. This is an indication that the tracking number was part of problem where the USPS Label Creation API created the same label number multiple times. This led to a confusing tracking experience, so tracking has been suppressed. Reference this ticket for more info: INC000010539853.

Result for Domestic Tracking Number 9414 8149 0236 8957 9355 42

Tracking Expires On
March 3, 2028

Destination and Origin

Destination

ZIP Code	City	State
64064	LEES SUMMIT	MO

Origin

City	State

Tracking Number Classification

Class/Service

Class/Service: First-Class Mail®
Class of Mail Code/Description: FC / First Class

Destination Address Information

Address: 1920 NE RICE RD
City: LEES SUMMIT
State: MO
5-Digit ZIP Code: 64064
4-Digit ZIP Code add on: 2123
Delivery Point Code: 20
Record Type Code: Street Record
Delivery Type: Business, Sidewalk

Service Delivery Information

PO Box: N

Other Information

Fraud Status: 12 - External tracking is suppressed because USPS has not received a payment record.

[Agent Information](#)

[Request Internal USPS Tracking Plus Statement](#)

Extra Services

Extra Services Details

Description	Amount
Certified Mail	
Return Receipt Electronic	

Events

[Help](#)



Product Tracking & Reporting

[Home](#)

[Search](#)

[Reports](#)

[Manual Entry](#)

[Rates/
Commitments](#)

[PTR / EDW](#)

[Customer
Information](#)

April 09, 2026

USPS Tracking Intranet

Delivery Signature and Address



1. Do not share information from this site outside of USPS. It is intended for USPS employee use only.
2. Employees may see some items with only event MT in the tracking record. This is an indication that the tracking number was part of problem where the USPS Label Creation API created the same label number multiple times. This led to a confusing tracking experience, so tracking has been suppressed. Reference this ticket for more info: INC000010539853.

Tracking Number: 9414 8149 0236 8957 9355 59

This item was delivered on 03/11/2026 at 11:31:00

[< Return to Tracking Number View](#)

Signature	 Patrick Higgins
Address	<p style="text-align: center;">200 N GAINES RD</p> <p style="text-align: center;">CEDAR CREEK, TX 78612-3167</p>

Enter up to 35 items separated by commas.

Select Search Type:

Quick Search



Submit

Product Tracking & Reporting, All Rights Reserved

Version: 26.2.1-9f61da1e

Product Tracking & Reporting



Home | About | Contact | Mailbox | Mailbox | Mailbox | Mailbox | Mailbox | Mailbox | Mailbox | Mailbox

USPS Tracking Intranet

Delivery Signature and Address

- 1. Do not share information from this site outside of USPS. It is intended for USPS employee use only.
- 2. Employees may see some items with only avon: MT in the tracking record. This is an indication that the tracking number was part of problem where the USPS Label Creation API created the same label number multiple times. This led to a confusing tracking experience, so tracking has been suppressed. Reference this ticket for more info: INC000010539853.

Tracking Number: 9414 8149 0238 8957 9355 68

This item was delivered on 03/05/2026 at 14:28:00

[Return to Tracking Number View](#)

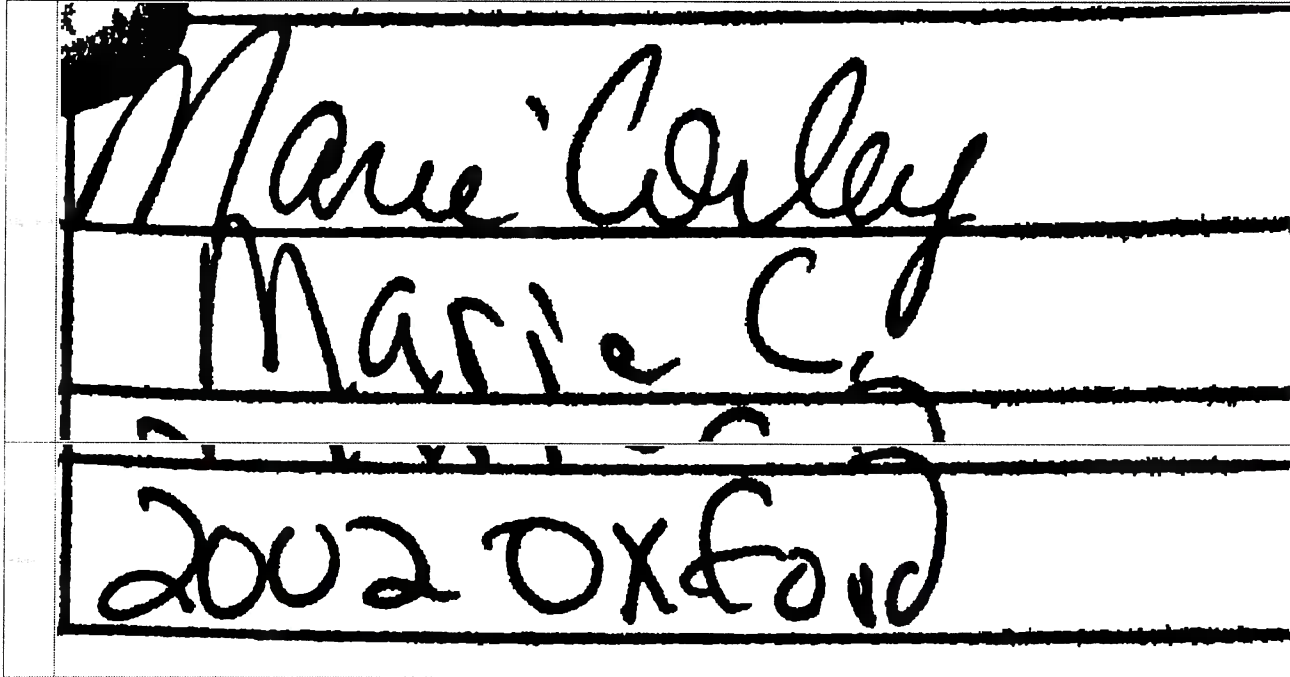

Enter up to 35 items separated by commas.

Select Search Type Quick Search

Product Tracking & Reporting. All Rights Reserved
Version: 26.2.1-8f61date

Product Tracking & Reporting



Home Search Reports Manual Entry Return Documents Site Setup Customer Information Customize

USPS Tracking Intranet

Delivery Signature and Address

1. Do not share information from this site outside of USPS. It is intended for USPS employee use only.
2. Employees may see some items with only event MT in the tracking record. This is an indication that the tracking number was part of a problem where the USPS Label Creation API created the same label number multiple times. This led to a confusing tracking experience, so tracking has been suppressed. Reference this ticket for more info: INC000010539853.

Tracking Number: 9414 8149 0238 8957 9355 73

This item was delivered on 03/08/2026 at 14:30:00

< Return to Tracking Number View

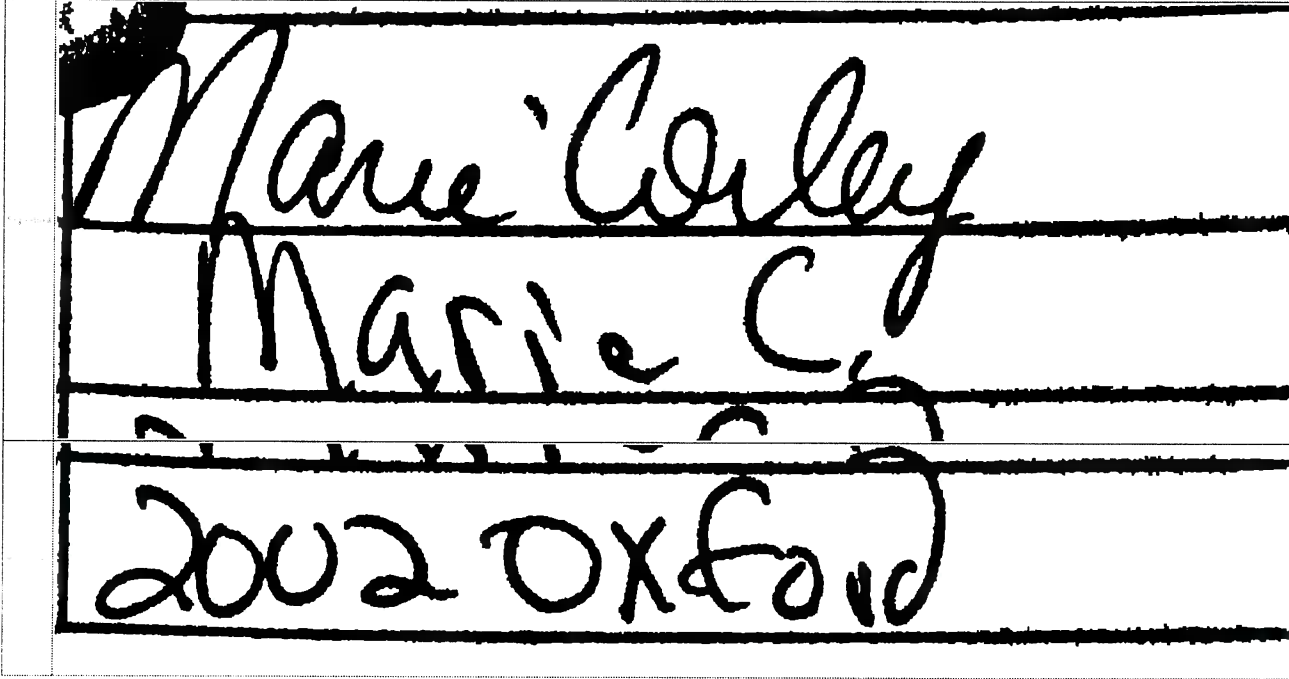

Enter up to 35 items separated by commas.

Select Search Type Quick Search Submit

Product Tracking & Reporting, All Rights Reserved
Version: 26.2.1-91510a1e

Product Tracking & Reporting



Home | Search | Refresh | Manual Entry | Public | Web-based | Customer Information | Help

USPS Tracking Intranet

Delivery Signature and Address

1. Do not share information from this site outside of USPS. It is intended for USPS employee use only.

2. Employees may see some items with only event MT in the tracking record. This is an indication that the tracking number was part of a problem where the USPS Label Creation API created the same label number multiple times. This led to a confusing tracking experience, so tracking has been suppressed. Reference this ticket for more info. INCC00010539853.

Tracking Number: 9414 8149 0236 8957 9355 80

This item was delivered on 03/09/2026 at 11:34:00

[Return to Tracking Number View](#)

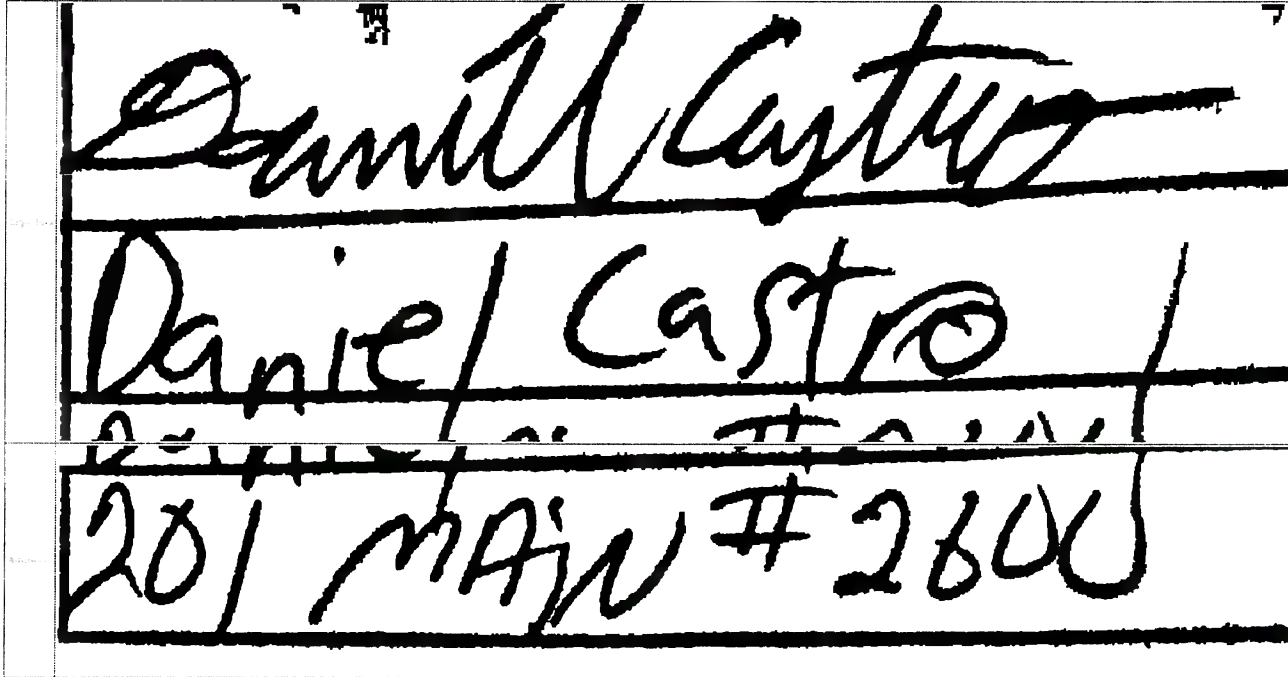

Enter up to 35 items separated by commas.

Select Search Type: Quick Search

Product Tracking & Reporting, All Rights Reserved
Version: 26.2.1-9101date

[Help](#)



Product Tracking & Reporting

[Home](#)

[Search](#)

[Reports](#)

[Manual Entry](#)

[Rates/
Commitments](#)

[PTR / EDW](#)

[Customer
Information](#)

April 09, 2026

USPS Tracking Intranet Tracking Number Result



1. Do not share information from this site outside of USPS. It is intended for USPS employee use only.
2. Employees may see some items with only event MT in the tracking record. This is an indication that the tracking number was part of problem where the USPS Label Creation API created the same label number multiple times. This led to a confusing tracking experience, so tracking has been suppressed. Reference this ticket for more info: INC000010539853.

Result for Domestic Tracking Number 9414 8149 0236 8957 9355 97

Tracking Expires On
March 3, 2028

Destination and Origin

Destination

ZIP Code	City	State
75201	DALLAS	TX

Origin

City	State

Tracking Number Classification

Class/Service

Class/Service: First-Class Mail®
Class of Mail Code/Description: FC / First Class

Destination Address Information

Address: 2021 MCKINNEY AVE STE 1250
City: DALLAS
State: TX
5-Digit ZIP Code: 75201
4-Digit ZIP Code add on: 7625
Delivery Point Code: 00
Record Type Code: Building/Apartment
Delivery Type: Business, CBU

Service Delivery Information

PO Box: N

Other Information

Fraud Status: 12 - External tracking is suppressed because USPS has not received a payment record.

[Agent Information](#)

[Request Internal USPS Tracking Plus Statement](#)

Extra Services

Extra Services Details

Description	Amount
Certified Mail	
Return Receipt Electronic	

Events

[Help](#)



Product Tracking & Reporting

[Home](#)

[Search](#)

[Reports](#)

[Manual Entry](#)

[Rates/
Commitments](#)

[PTR / EDW](#)

[Customer
Information](#)

Apr 10, 2026

USPS Tracking Intranet

Delivery Signature and Address



1. Do not share information from this site outside of USPS. It is intended for USPS employee use only.
2. Employees may see some items with only event MT in the tracking record. This is an indication that the tracking number was part of problem where the USPS Label Creation API created the same label number multiple times. This led to a confusing tracking experience, so tracking has been suppressed. Reference this ticket for more info: INC000010539853.

Tracking Number: 9414 8149 0236 8957 9356 03

This item was delivered on 03/07/2026 at 12:20:00

[< Return to Tracking Number View](#)

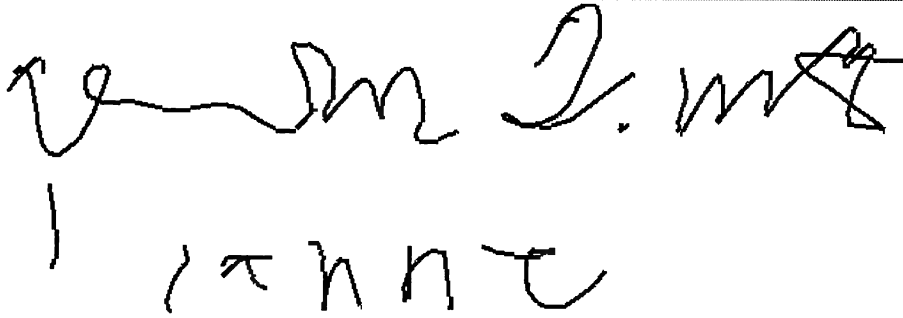
Signature	
Address	<p>20230 ATASCOCITA LAKE DR, HUMBLE, TX 77346</p>

Enter up to 35 items separated by commas.

Select Search Type:

Quick Search



Submit

Product Tracking & Reporting, All Rights Reserved

Version: 26.2.1-9f61da1e

[Help](#)



Product Tracking & Reporting

[Home](#)

[Search](#)

[Reports](#)

[Manual Entry](#)

[Rates/
Commitments](#)

[PTR / EDW](#)

[Customer
Information](#)

April 09, 2026

USPS Tracking Intranet

Delivery Signature and Address



1. Do not share information from this site outside of USPS. It is intended for USPS employee use only.
2. Employees may see some items with only event MT in the tracking record. This is an indication that the tracking number was part of problem where the USPS Label Creation API created the same label number multiple times. This led to a confusing tracking experience, so tracking has been suppressed. Reference this ticket for more info: INC000010539853.

Tracking Number: 9414 8149 0236 8957 9356 10

This item was delivered on 03/09/2026 at 12:51:00

[< Return to Tracking Number View](#)

Signature	 Kaulcher
Address	20602 Laverfon

Enter up to 35 items separated by commas.

Select Search Type:

Quick Search



Submit

Product Tracking & Reporting, All Rights Reserved

Version: 26.2.1-9f61da1e

[Help](#)



Product Tracking & Reporting

[Home](#)

[Search](#)

[Reports](#)

[Manual Entry](#)

[Rates/
Commitments](#)

[PTR / EDW](#)

[Customer
Information](#)

April 09, 2026

USPS Tracking Intranet

Delivery Signature and Address



1. Do not share information from this site outside of USPS. It is intended for USPS employee use only.
2. Employees may see some items with only event MT in the tracking record. This is an indication that the tracking number was part of problem where the USPS Label Creation API created the same label number multiple times. This led to a confusing tracking experience, so tracking has been suppressed. Reference this ticket for more info: INC000010539853.

Tracking Number: 9414 8149 0236 8957 9356 27

This item was delivered on 03/07/2026 at 12:46:00

[< Return to Tracking Number View](#)

Delivery Section	
Signature	<p>X</p> <p>215 [Signature]</p>
Printed Name	215 [Signature]
Address	[Redacted]

Enter up to 35 items separated by commas.

Select Search Type:

Quick Search



Submit

Product Tracking & Reporting, All Rights Reserved

Version: 26.2.1-9f61da1e

Help



Product Tracking & Reporting

Home

Search

Reports

Manual Entry

Rates/
Commitments

PTR / EDW

Customer
Information

April 09, 2026

USPS Tracking Intranet

Delivery Signature and Address



- 1. Do not share information from this site outside of USPS. It is intended for USPS employee use only.
- 2. Employees may see some items with only event MT in the tracking record. This is an indication that the tracking number was part of problem where the USPS Label Creation API created the same label number multiple times. This led to a confusing tracking experience, so tracking has been suppressed. Reference this ticket for more info: INC000010539853.

Tracking Number: 9414 8149 0236 8957 9356 34

This item was delivered on 03/25/2026 at 09:46:00

[< Return to Tracking Number View](#)

Signature	Signature X	Sarah Leyva
	Printed Name	Sarah Leyva
Address	Delivery Address	3617 N Big Spring

Enter up to 35 items separated by commas.

Select Search Type:

Quick Search



Submit

Product Tracking & Reporting, All Rights Reserved
Version: 26.2.1-9f61da1e



Product Tracking & Reporting

Home

Search

Reports

Manual Entry

Rates/
Commitments

PTR / EDW

Customer
Information

April 09, 2026

USPS Tracking Intranet

Delivery Signature and Address





1. Do not share information from this site outside of USPS. It is intended for USPS employee use only.
2. Employees may see some items with only event MT in the tracking record. This is an indication that the tracking number was part of problem where the USPS Label Creation API created the same label number multiple times. This led to a confusing tracking experience, so tracking has been suppressed. Reference this ticket for more info: INC000010539853.

Tracking Number: 9414 8149 0236 8957 9356 41

This item was delivered on 03/06/2026 at 12:10:00

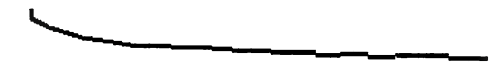
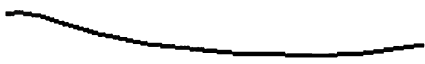
[< Return to Tracking Number View](#)

Signature	 
Address	

Enter up to 35 items separated by commas.

Select Search Type:

Quick Search



Submit

Product Tracking & Reporting, All Rights Reserved
Version: 26.2.1-9f61da1e

[Help](#)



Product Tracking & Reporting

[Home](#)

[Search](#)

[Reports](#)

[Manual Entry](#)

[Rates/
Commitments](#)

[PTR / EDW](#)

[Customer
Information](#)

April 09, 2026

USPS Tracking Intranet

Delivery Signature and Address



1. Do not share information from this site outside of USPS. It is intended for USPS employee use only.
2. Employees may see some items with only event MT in the tracking record. This is an indication that the tracking number was part of problem where the USPS Label Creation API created the same label number multiple times. This led to a confusing tracking experience, so tracking has been suppressed. Reference this ticket for more info: INC000010539853.

Tracking Number: 9414 8149 0236 8957 9356 58

This item was delivered on 03/09/2026 at 07:59:00

[< Return to Tracking Number View](#)

Delivery Signature	
Signature X	
Printed Name	Marcus A. Bavela
Address	1148

Enter up to 35 items separated by commas.

Select Search Type:

Quick Search

Product Tracking & Reporting, All Rights Reserved
Version: 26.2.1-9f61da1e

[Help](#)



Product Tracking & Reporting

[Home](#)

[Search](#)

[Reports](#)

[Manual Entry](#)

[Rates/
Commitments](#)

[PTR / EDW](#)

[Customer
Information](#)

April 09, 2026

USPS Tracking Intranet

Delivery Signature and Address



1. Do not share information from this site outside of USPS. It is intended for USPS employee use only.
2. Employees may see some items with only event MT in the tracking record. This is an indication that the tracking number was part of problem where the USPS Label Creation API created the same label number multiple times. This led to a confusing tracking experience, so tracking has been suppressed. Reference this ticket for more info: INC000010539853.

Tracking Number: 9414 8149 0236 8957 9356 65

This item was delivered on 03/09/2026 at 07:28:00

[< Return to Tracking Number View](#)

Signature	<p style="text-align: center;">Delivery Section</p> <p>Signature</p> <p>X <i>[Handwritten Signature]</i></p>
	<p>Printed Name</p> <p><i>[Handwritten Name]</i></p>
Address	<p>Delivery Address</p> <p><i>[Handwritten Address]</i></p>

Enter up to 35 items separated by commas.

Select Search Type:

Quick Search

Product Tracking & Reporting, All Rights Reserved
Version: 26.2.1-9f61da1e

[Help](#)



Product Tracking & Reporting

[Home](#)

[Search](#)

[Reports](#)

[Manual Entry](#)

[Rates/
Commitments](#)

[PTR / EDW](#)

[Customer
Information](#)

April 09, 2026

USPS Tracking Intranet

Delivery Signature and Address



- 1. Do not share information from this site outside of USPS. It is intended for USPS employee use only.
- 2. Employees may see some items with only event MT in the tracking record. This is an indication that the tracking number was part of problem where the USPS Label Creation API created the same label number multiple times. This led to a confusing tracking experience, so tracking has been suppressed. Reference this ticket for more info: INC000010539853.

Tracking Number: 9414 8149 0236 8957 9356 72

This item was delivered on 03/06/2026 at 13:48:00

[< Return to Tracking Number View](#)

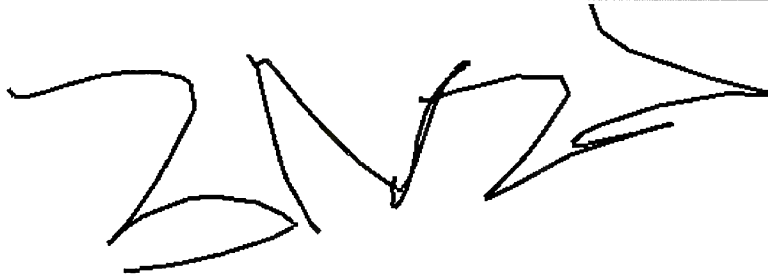
Signature	
Address	

Enter up to 35 items separated by commas.

Select Search Type:

Quick Search



Submit

Product Tracking & Reporting, All Rights Reserved
Version: 26.2.1-9f61da1e

[Help](#)



Product Tracking & Reporting

[Home](#)

[Search](#)

[Reports](#)

[Manual Entry](#)

[Rates/
Commitments](#)

[PTR / EDW](#)

[Customer
Information](#)

April 09, 2026

USPS Tracking Intranet

Delivery Signature and Address



1. Do not share information from this site outside of USPS. It is intended for USPS employee use only.
2. Employees may see some items with only event MT in the tracking record. This is an indication that the tracking number was part of problem where the USPS Label Creation API created the same label number multiple times. This led to a confusing tracking experience, so tracking has been suppressed. Reference this ticket for more info: INC000010539853.

Tracking Number: 9414 8149 0236 8957 9356 89

This item was delivered on 03/07/2026 at 13:42:00

[< Return to Tracking Number View](#)

Signature	
Address	<p>3519 GLEN LOCH CT, ROCKINGHAM, VA 22801</p>

Enter up to 35 items separated by commas.

Select Search Type:

Quick Search

Product Tracking & Reporting, All Rights Reserved
Version: 26.2.1-9f61da1e

Help



Product Tracking & Reporting

Home

Search

Reports

Manual Entry

Rates/
Commitments

PTR / EDW

Customer
Information

April 09, 2026

USPS Tracking Intranet

Delivery Signature and Address





1. Do not share information from this site outside of USPS. It is intended for USPS employee use only.
2. Employees may see some items with only event MT in the tracking record. This is an indication that the tracking number was part of problem where the USPS Label Creation API created the same label number multiple times. This led to a confusing tracking experience, so tracking has been suppressed. Reference this ticket for more info: INC000010539853.

Tracking Number: 9414 8149 0236 8957 9357 19

This item was delivered on 03/07/2026 at 17:04:00

[< Return to Tracking Number View](#)

Signature	
Address	

Enter up to 35 items separated by commas.

Select Search Type:

Quick Search



Submit

Product Tracking & Reporting, All Rights Reserved

Version: 26.2.1-9f61da1e

[Help](#)



Product Tracking & Reporting

[Home](#)

[Search](#)

[Reports](#)

[Manual Entry](#)

[Rates/
Commitments](#)

[PTR / EDW](#)

[Customer
Information](#)

April 09, 2026

USPS Tracking Intranet

Delivery Signature and Address





1. Do not share information from this site outside of USPS. It is intended for USPS employee use only.
2. Employees may see some items with only event MT in the tracking record. This is an indication that the tracking number was part of problem where the USPS Label Creation API created the same label number multiple times. This led to a confusing tracking experience, so tracking has been suppressed. Reference this ticket for more info: INC000010539853.

Tracking Number: 9414 8149 0236 8957 9357 26

This item was delivered on 03/07/2026 at 17:03:00

[< Return to Tracking Number View](#)

Signature	
Address	

Enter up to 35 items separated by commas.

Select Search Type:

Quick Search

Product Tracking & Reporting, All Rights Reserved
Version: 26.2.1-9f61da1e

[Help](#)



Product Tracking & Reporting

[Home](#)

[Search](#)

[Reports](#)

[Manual Entry](#)

[Rates/
Commitments](#)

[PTR / EDW](#)

[Customer
Information](#)

April 09, 2026

USPS Tracking Intranet

Delivery Signature and Address



- 1. Do not share information from this site outside of USPS. It is intended for USPS employee use only.
- 2. Employees may see some items with only event MT in the tracking record. This is an indication that the tracking number was part of problem where the USPS Label Creation API created the same label number multiple times. This led to a confusing tracking experience, so tracking has been suppressed. Reference this ticket for more info: INC000010539853.

Tracking Number: 9414 8149 0236 8957 9357 33

This item was delivered on 03/09/2026 at 13:34:00

[< Return to Tracking Number View](#)

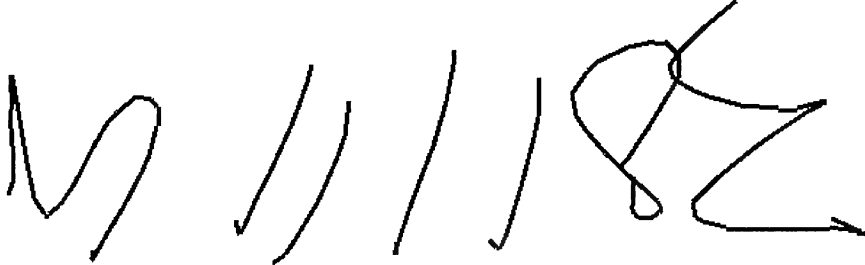
Signature	
Address	

Enter up to 35 items separated by commas.

Select Search Type:

Quick Search



Submit

Product Tracking & Reporting, All Rights Reserved
Version: 26.2.1-9f61da1e

Product Tracking & Reporting



Home Search Reports Manual Entry P&R My Dashboard P&R FEED Customer Information Settings

USPS Tracking Intranet

Delivery Signature and Address



- 1. Do not share information from this site outside of USPS. It is intended for USPS employee use only.
- 2. Employees may see some items with only event MT in the tracking record. This is an indication that the tracking number was part of a problem where the USPS Label Creation API created the same label number multiple times. This led to a confusing tracking experience, so tracking has been suppressed. Reference this ticket for more info: INC000010539853.

Tracking Number: 9414 8149 0238 8957 9357 40

This item was delivered on 03/09/2026 at 13:17:00

[Return to Tracking Number View](#)

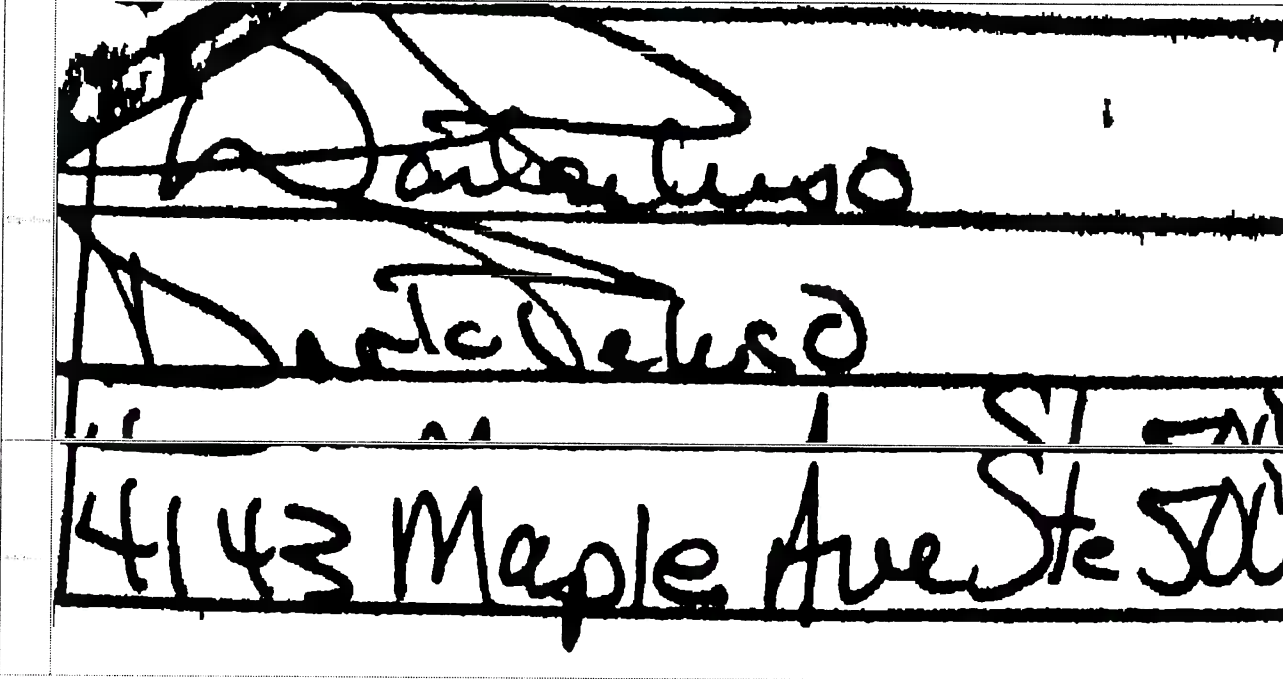

Enter up to 35 items separated by commas.

Select Search Type Quick Search

Product Tracking & Reporting, All Rights Reserved
Version: 26.2.1-0151date

Product Tracking & Reporting



Home | Search | Results | Manual Entry | Filter | Print | Help | Customer | Feedback

USPS Tracking Intranet

Delivery Signature and Address

1. Do not share information from this site outside of USPS. It is intended for USPS employee use only.

2. Employees may see some items with only event MT in the tracking record. This is an indication that the tracking number was part of a problem where the USPS Label Creation API created the same label number multiple times. This led to a confusing tracking experience, so tracking has been suppressed. Reference this ticket for more info: INC000010539953.

Tracking Number: 9414 8149 0236 8857 9357 57

This item was delivered on 03/09/2026 at 13:18:00

[Return to Tracking Number View](#)

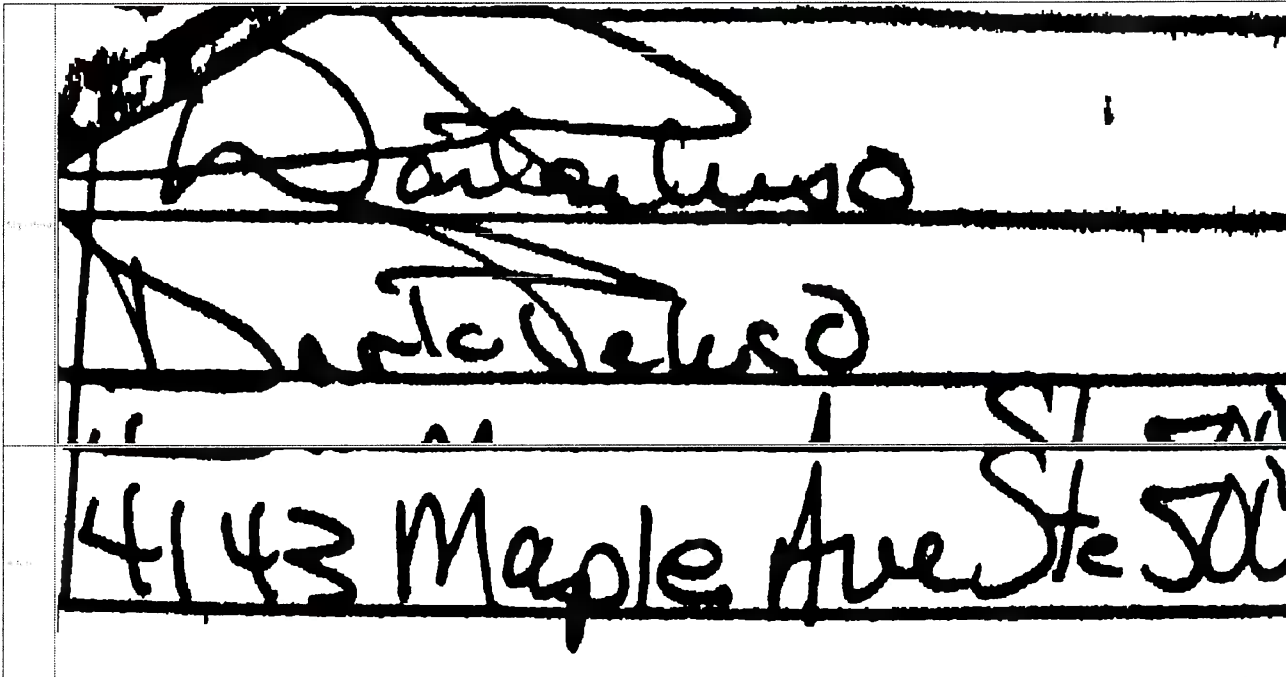

Enter up to 35 items separated by commas.

Select Search Type Quick Search

Product Tracking & Reporting. All Rights Reserved
Version: 26.2.1-961d4e

Product Tracking & Reporting



Home Search Reports Manual Entry My Mail Query Address PTP ZEDW Customer Information Contact Us

USPS Tracking Intranet

Delivery Signature and Address

- 1. Do not share information from this site outside of USPS. It is intended for USPS employee use only.
- 2. Employees may see some items with only event MT in the tracking record. This is an indication that the tracking number was part of a problem where the USPS Label Creation API created the same label number multiple times. This led to a confusing tracking experience, so tracking has been suppressed. Reference this ticket for more info: INC000010539853.

Tracking Number: 9414 8149 0236 8957 9357 64

This item was delivered on 03/09/2026 at 13:18:00

[Return to Tracking Number View](#)

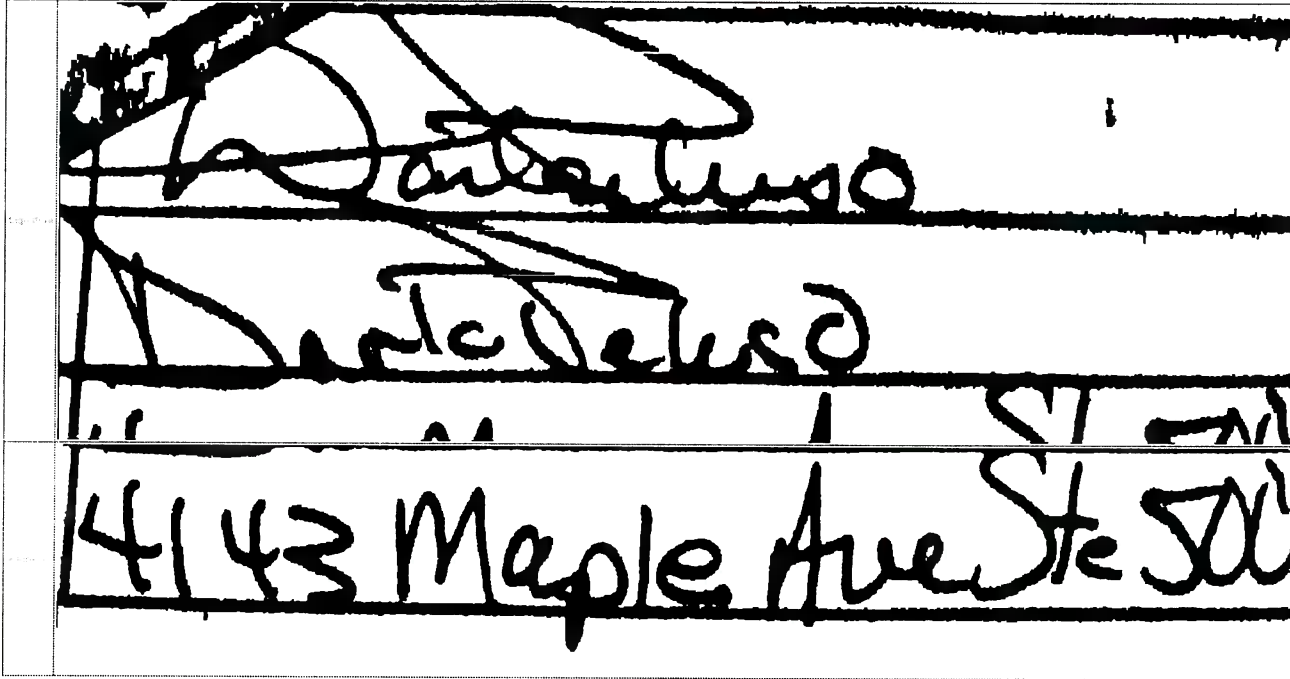

Enter up to 35 items separated by commas.

Select Search Type: Quick Search

Product Tracking & Reporting, All Rights Reserved
Version: 28.2.1-981646

Product Tracking & Reporting



Home Search Alerts Manual Entry Print Document APPS/CSV Customer Information Audit Log

USPS Tracking Intranet

Delivery Signature and Address

1. Do not share information from this site outside of USPS. It is intended for USPS employee use only.

2. Employees may see some items with only event MT in the tracking record. This is an indication that the tracking number was part of problem where the USPS Label Creation API created the same label number multiple times. This led to a confusing tracking experience, so tracking has been suppressed. Reference this ticket for more info. INC000010538653.

Tracking Number: 9414 8149 0236 8957 9357 71

This item was delivered on 03/09/2026 at 13:17:00

[Return to Tracking Number View](#)

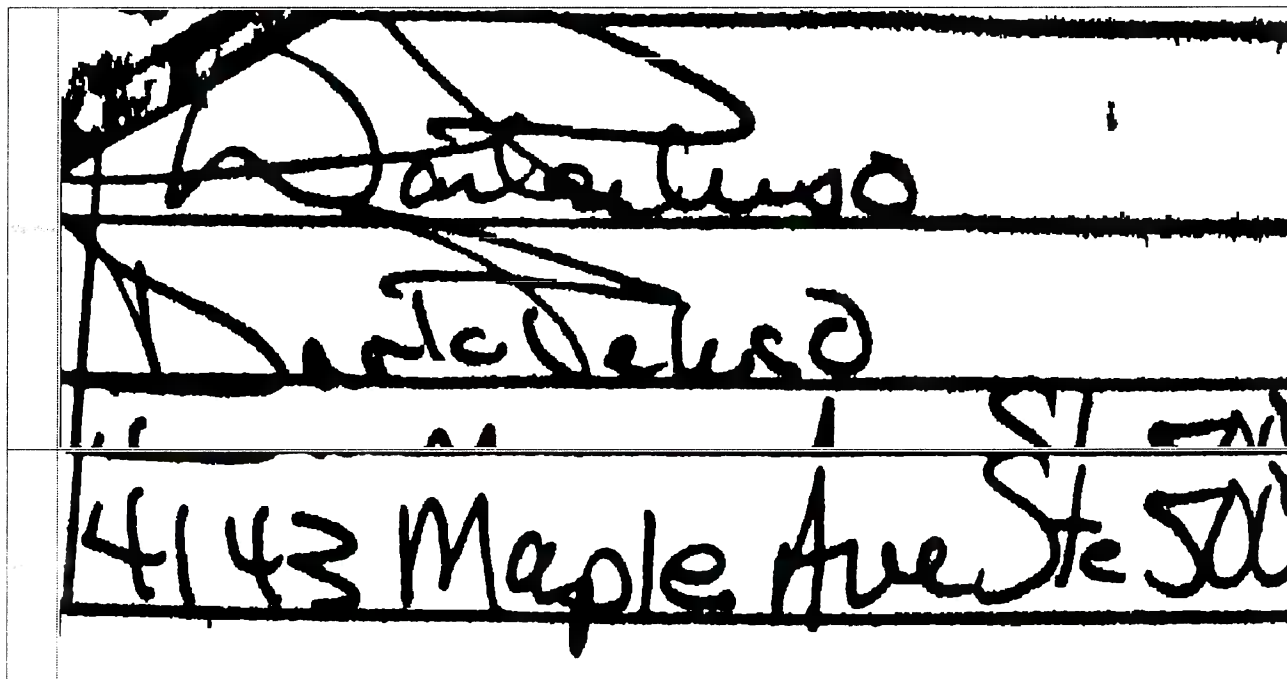

Enter up to 35 items separated by commas.

Select Search Type: Quick Search

Product Tracking & Reporting, All Rights Reserved
Version: 28.2.1-981da1e

Product Tracking & Reporting



Home Search Results Manual Entry Print Labels Print EDW Customer Information Contact Us

USPS Tracking Intranet

Delivery Signature and Address

- 1. Do not share information from this site outside of USPS. It is intended for USPS employee use only.
- 2. Employees may see some items with only event MT in the tracking record. This is an indication that the tracking number was part of problem where the USPS Label Creation API created the same label number multiple times. This led to a confusing tracking experience, so tracking has been suppressed. Reference this ticket for more info: INC000010539853.

Tracking Number: 9414 8149 0236 8957 9357 88

This item was delivered on 03/09/2026 at 13:18:00

[Return to Tracking Number View](#)

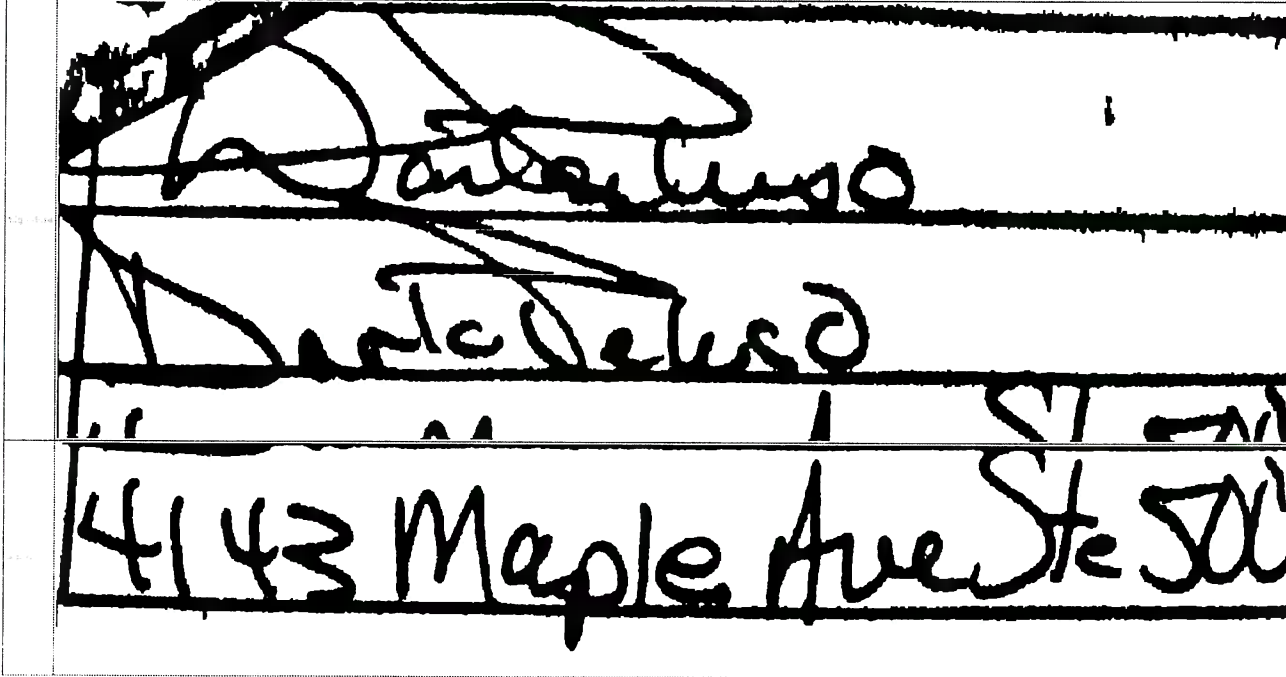

Enter up to 35 items separated by commas.

Select Search Type Quick Search

Product Tracking & Reporting, All Rights Reserved
Version: 26.2.1-9161date

[Help](#)



Product Tracking & Reporting

[Home](#)

[Search](#)

[Reports](#)

[Manual Entry](#)

[Rates/
Commitments](#)

[PTR / EDW](#)

[Customer
Information](#)

April 09, 2026

USPS Tracking Intranet

Delivery Signature and Address



1. Do not share information from this site outside of USPS. It is intended for USPS employee use only.
2. Employees may see some items with only event MT in the tracking record. This is an indication that the tracking number was part of problem where the USPS Label Creation API created the same label number multiple times. This led to a confusing tracking experience, so tracking has been suppressed. Reference this ticket for more info: INC000010539853.

Tracking Number: 9414 8149 0236 8957 9357 95

This item was delivered on 03/24/2026 at 09:21:00

[< Return to Tracking Number View](#)

Delivery Section					
Signature	<table border="1"> <tr> <td>Signature X</td> <td><i>Sarah Lynn</i></td> </tr> <tr> <td>Printed Name</td> <td>Sarah Lynn</td> </tr> </table>	Signature X	<i>Sarah Lynn</i>	Printed Name	Sarah Lynn
Signature X	<i>Sarah Lynn</i>				
Printed Name	Sarah Lynn				
Address	<table border="1"> <tr> <td>Delivery Address</td> <td>3617 N Big Spring</td> </tr> </table>	Delivery Address	3617 N Big Spring		
Delivery Address	3617 N Big Spring				

Enter up to 35 items separated by commas.

Select Search Type:

Quick Search



Submit

Product Tracking & Reporting, All Rights Reserved

Version: 26.2.1-9f61da1e

Product Tracking & Reporting



Home | General | Reports | Manual Entry | Error Management | Data Entry | Customer Information | Tools

USPS Tracking Intranet

Delivery Signature and Address

1. Do not share information from this site outside of USPS. It is intended for USPS employee use only.

2. Employees may see some items with only event MT in the tracking record. This is an indication that the tracking number was part of a problem where the USPS Label Creation API created the same label number multiple times. This led to a confusing tracking experience, so tracking has been suppressed. Reference this ticket for more info: INC00010539953.

Tracking Number: 9414 8149 0234 8957 9358 01

This item was delivered on 03/07/2026 at 13:38:00

[Return to Tracking Number View](#)

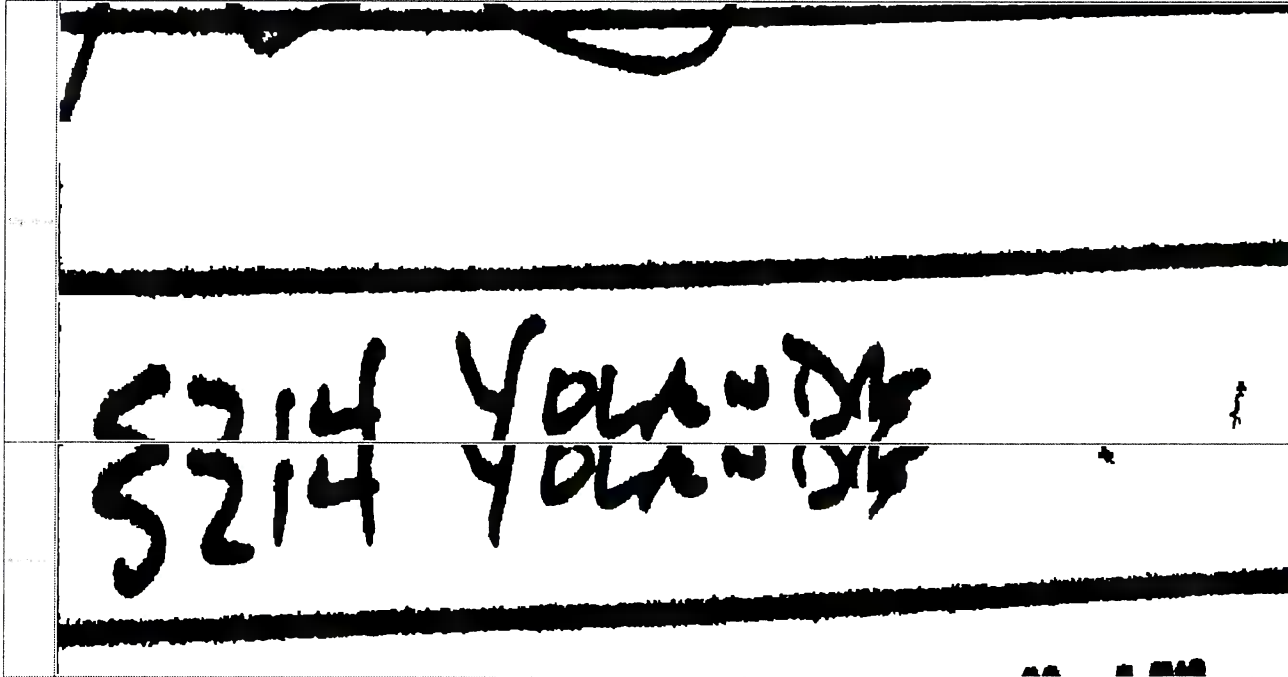

Enter up to 35 items separated by commas.

Select Search Type Quick Search

Product Tracking & Reporting, All Rights Reserved
Version: 28.2.1-9161date

[Help](#)



Product Tracking & Reporting

[Home](#)

[Search](#)

[Reports](#)

[Manual Entry](#)

[Rates/
Commitments](#)

[PTR / EDW](#)

[Customer
Information](#)

April 09, 2026

USPS Tracking Intranet

Delivery Signature and Address



1. Do not share information from this site outside of USPS. It is intended for USPS employee use only.
2. Employees may see some items with only event MT in the tracking record. This is an indication that the tracking number was part of problem where the USPS Label Creation API created the same label number multiple times. This led to a confusing tracking experience, so tracking has been suppressed. Reference this ticket for more info: INC000010539853.

Tracking Number: 9414 8149 0236 8957 9358 18

This item was delivered on 03/05/2026 at 08:05:00

[< Return to Tracking Number View](#)

Signature	Delivery Section	
Address	600 W Illinois	
	Delivery Address	

Enter up to 35 items separated by commas.

Select Search Type:

Quick Search



Submit

Product Tracking & Reporting, All Rights Reserved

Version: 26.2.1-9f61da1e

[Help](#)



Product Tracking & Reporting

[Home](#)

[Search](#)

[Reports](#)

[Manual Entry](#)

[Rates/
Commitments](#)

[PTR / EDW](#)

[Customer
Information](#)

April 09, 2026

USPS Tracking Intranet

Delivery Signature and Address



1. Do not share information from this site outside of USPS. It is intended for USPS employee use only.
2. Employees may see some items with only event MT in the tracking record. This is an indication that the tracking number was part of problem where the USPS Label Creation API created the same label number multiple times. This led to a confusing tracking experience, so tracking has been suppressed. Reference this ticket for more info: INC000010539853.

Tracking Number: 9414 8149 0236 8957 9358 25

This item was delivered on 03/09/2026 at 14:25:00

[< Return to Tracking Number View](#)

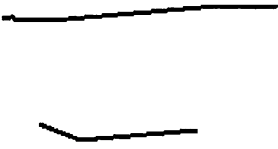
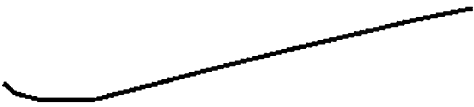
Signature	
Address	

Enter up to 35 items separated by commas.

Select Search Type:

Quick Search

Product Tracking & Reporting, All Rights Reserved
Version: 26.2.1-9f61da1e

[Help](#)



Product Tracking & Reporting

[Home](#)

[Search](#)

[Reports](#)

[Manual Entry](#)

[Rates/
Commitments](#)

[PTR / EDW](#)

[Customer
Information](#)

April 09, 2026

USPS Tracking Intranet

Delivery Signature and Address





1. Do not share information from this site outside of USPS. It is intended for USPS employee use only.
2. Employees may see some items with only event MT in the tracking record. This is an indication that the tracking number was part of problem where the USPS Label Creation API created the same label number multiple times. This led to a confusing tracking experience, so tracking has been suppressed. Reference this ticket for more info: INC000010539853.

Tracking Number: 9414 8149 0236 8957 9358 32

This item was delivered on 03/09/2026 at 14:25:00

[< Return to Tracking Number View](#)

Signature	
Address	

Enter up to 35 items separated by commas.

Select Search Type:

Quick Search ▼

Product Tracking & Reporting, All Rights Reserved
Version: 26.2.1-9f61da1e

[Help](#)



Product Tracking & Reporting

[Home](#)

[Search](#)

[Reports](#)

[Manual Entry](#)

[Rates/
Commitments](#)

[PTR / EDW](#)

[Customer
Information](#)

Apr 09 2026

USPS Tracking Intranet

Delivery Signature and Address



1. Do not share information from this site outside of USPS. It is intended for USPS employee use only.
2. Employees may see some items with only event MT in the tracking record. This is an indication that the tracking number was part of problem where the USPS Label Creation API created the same label number multiple times. This led to a confusing tracking experience, so tracking has been suppressed. Reference this ticket for more info: INC000010539853.

Tracking Number: 9414 8149 0236 8957 9358 49

This item was delivered on 03/13/2026 at 11:48:00

[< Return to Tracking Number View](#)

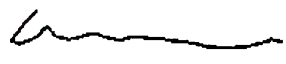
Signature	 Davian Daw
Address	710 Christopher Dr

Enter up to 35 items separated by commas.

Select Search Type:

Quick Search



Submit

Product Tracking & Reporting, All Rights Reserved
Version: 26.2.1-9f61da1e

[Help](#)



Product Tracking & Reporting

[Home](#)

[Search](#)

[Reports](#)

[Manual Entry](#)

[Rates/
Commitments](#)

[PTR / EDW](#)

[Customer
Information](#)

April 09, 2026

USPS Tracking Intranet

Delivery Signature and Address



1. Do not share information from this site outside of USPS. It is intended for USPS employee use only.
2. Employees may see some items with only event MT in the tracking record. This is an indication that the tracking number was part of problem where the USPS Label Creation API created the same label number multiple times. This led to a confusing tracking experience, so tracking has been suppressed. Reference this ticket for more info: INC000010539853.

Tracking Number: 9414 8149 0236 8957 9358 56

This item was delivered on 03/10/2026 at 15:07:00

[< Return to Tracking Number View](#)

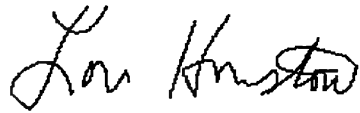
Signature	 Lori Howston
Address	901 W 8TH ST IDALOU, TX 79329-9058

Enter up to 35 items separated by commas.

Select Search Type:

Quick Search



Submit

Product Tracking & Reporting, All Rights Reserved

Version: 26.2.1-9f61da1e

[Help](#)



Product Tracking & Reporting

[Home](#)

[Search](#)

[Reports](#)

[Manual Entry](#)

[Rates/
Commitments](#)

[PTR / EDW](#)

[Customer
Information](#)

April 09, 2026

USPS Tracking Intranet

Delivery Signature and Address



1. Do not share information from this site outside of USPS. It is intended for USPS employee use only.
2. Employees may see some items with only event MT in the tracking record. This is an indication that the tracking number was part of problem where the USPS Label Creation API created the same label number multiple times. This led to a confusing tracking experience, so tracking has been suppressed. Reference this ticket for more info: INC000010539853.

Tracking Number: 9414 8149 0236 8957 9358 63

This item was delivered on 03/10/2026 at 15:07:00

[< Return to Tracking Number View](#)

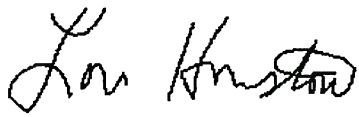
Signature	 Lori Houston
Address	901 W 8TH ST IDALOU, TX 79329-9058

Enter up to 35 items separated by commas.

Select Search Type:

Quick Search



Submit

Product Tracking & Reporting, All Rights Reserved
Version: 26.2.1-9f61da1e

Product Tracking & Reporting



Home | Search | Reports | Manual Entry | Help | Community | FEEDBACK | Customer Information | Settings

USPS Tracking Intranet
Delivery Signature and Address

1. Do not share information from this site outside of USPS. It is intended for USPS employee use only.
2. Employees may see some items with only event MT in the tracking record. This is an indication that the tracking number was part of a problem where the USPS Label Creation API created the same label number multiple times. This led to a confusing tracking experience, so tracking has been suppressed. Reference this ticket for more info. INC000010539653

Tracking Number: 9414 8149 0238 8957 9358 70

This item was delivered on 03/06/2026 at 09:53:00

[Return to Tracking Number View](#)

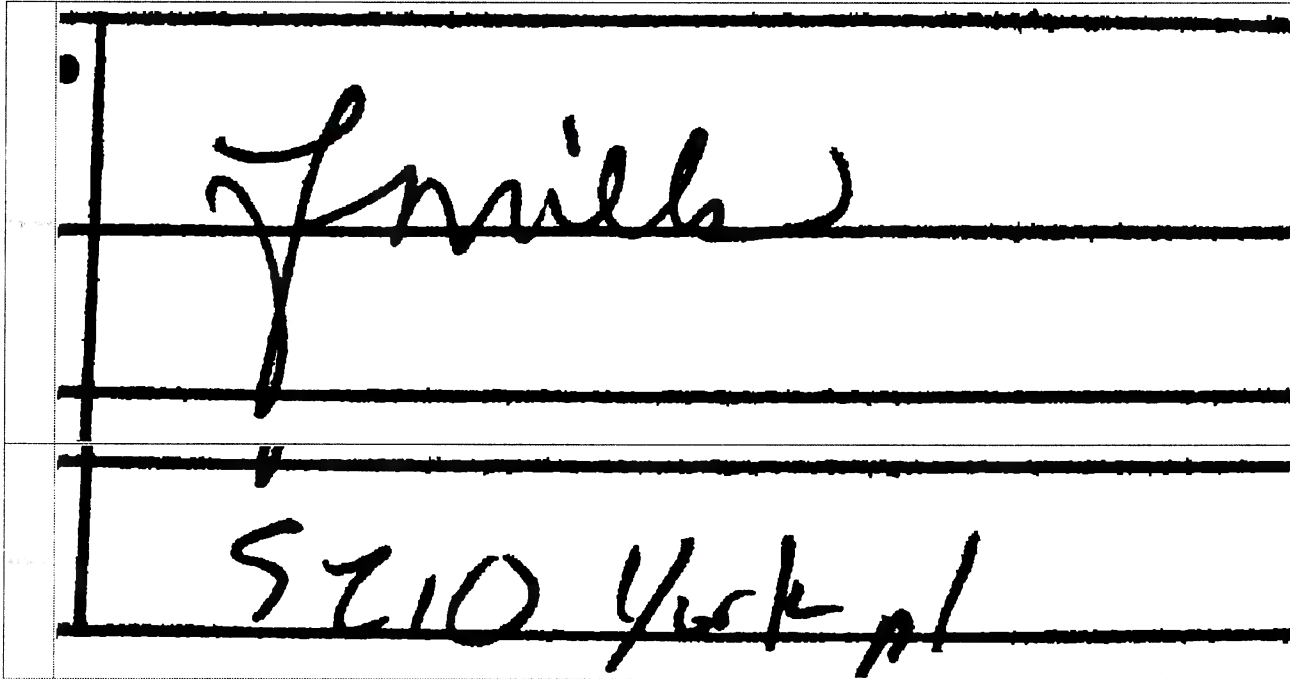

Enter up to 35 items separated by commas.

Select Search Type: Quick Search

Product Tracking & Reporting, All Rights Reserved
Version: 26.2.1-981date

Product Tracking & Reporting



Home Search Alerts Mailbox My Mailbox My Mailbox My Mailbox My Mailbox My Mailbox My Mailbox My Mailbox My Mailbox My Mailbox

USPS Tracking Intranet

Delivery Signature and Address

1. Do not share information from this site outside of USPS. It is intended for USPS employee use only.
2. Employees may see some items with only event MT in the tracking record. This is an indication that the tracking number was part of problem where the USPS Label Creation API created the same label number multiple times. This led to a confusing tracking experience, so tracking has been suppressed. Reference this ticket for more info. IHC000010538653.

Tracking Number: 9414 8149 0236 8957 9358 87

This item was delivered on 03/06/2026 at 09:53:00

[Return to Tracking Number View](#)

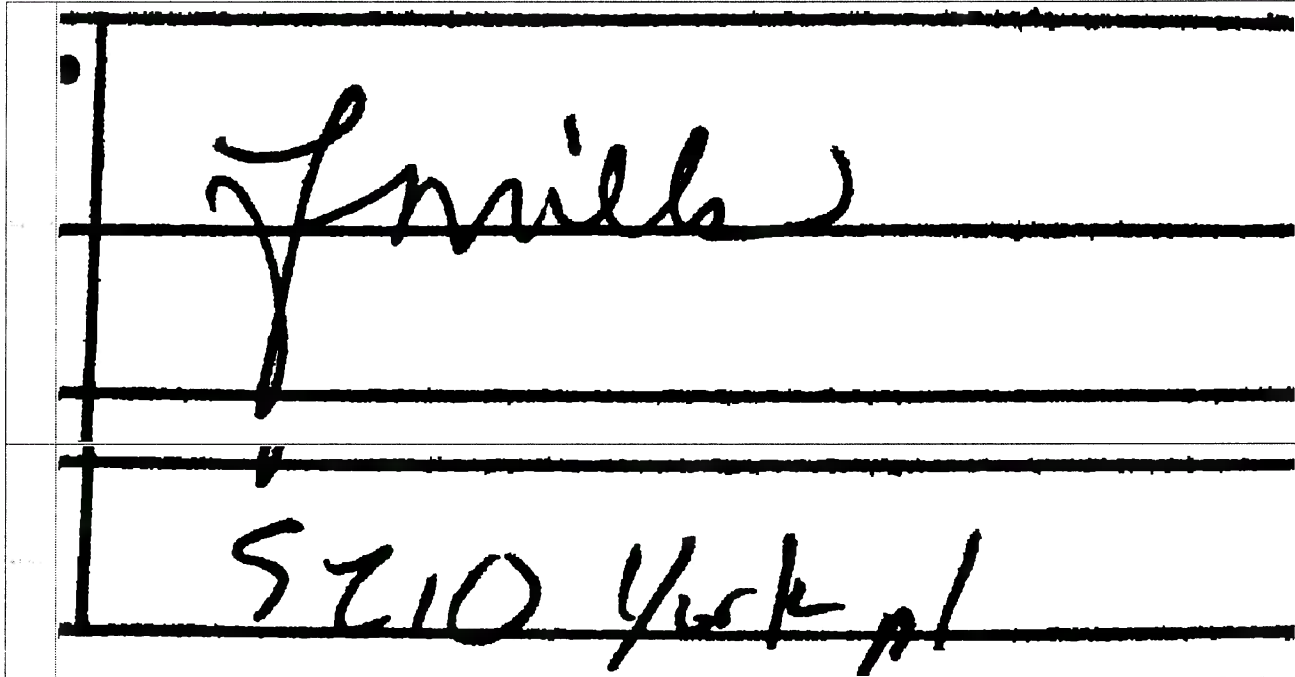

Enter up to 35 items separated by commas.

Select Search Type Quick Search

Product Tracking & Reporting. All Rights Reserved
Version: 28.2.1-861da1e

Product Tracking & Reporting



Home | About | Reports | Mailbox | Product Information | Support | Customer Information | About Us

USPS Tracking Intranet

Delivery Signature and Address

1. Do not share information from this site outside of USPS. It is intended for USPS employee use only.

2. Employees may see some items with only event MT in the tracking record. This is an indication that the tracking number was part of problem where the USPS Label Creation API created the same label number multiple times. This led to a confusing tracking experience, so tracking has been suppressed. Reference this ticket for more info. INC000010539853.

Tracking Number: 9414 8149 0238 8957 9358 94

This item was delivered on 03/07/2026 at 12:53:00

[Return to Tracking Number View](#)

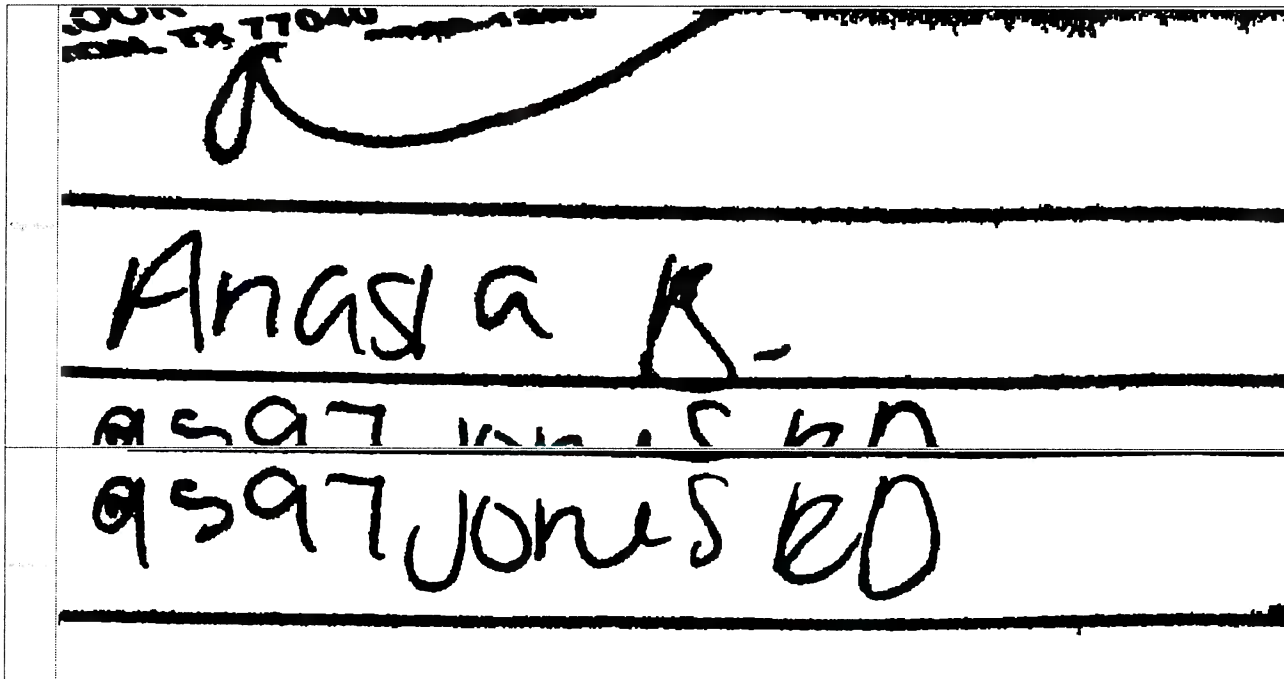

Enter up to 35 items separated by commas.

Select Search Type Quick Search

Product Tracking & Reporting. All Rights Reserved
Version: 28.2.1-981da1e

Help



Product Tracking & Reporting

Home

Search

Reports

Manual Entry

Rates/
Commitments

PTR / EDW

Customer
Information

April 09, 2026

USPS Tracking Intranet

Delivery Signature and Address



- 1. Do not share information from this site outside of USPS. It is intended for USPS employee use only.
- 2. Employees may see some items with only event MT in the tracking record. This is an indication that the tracking number was part of problem where the USPS Label Creation API created the same label number multiple times. This led to a confusing tracking experience, so tracking has been suppressed. Reference this ticket for more info: INC000010539853.

Tracking Number: 9414 8149 0236 8957 9359 00

This item was delivered on 03/07/2026 at 10:28:00

[< Return to Tracking Number View](#)

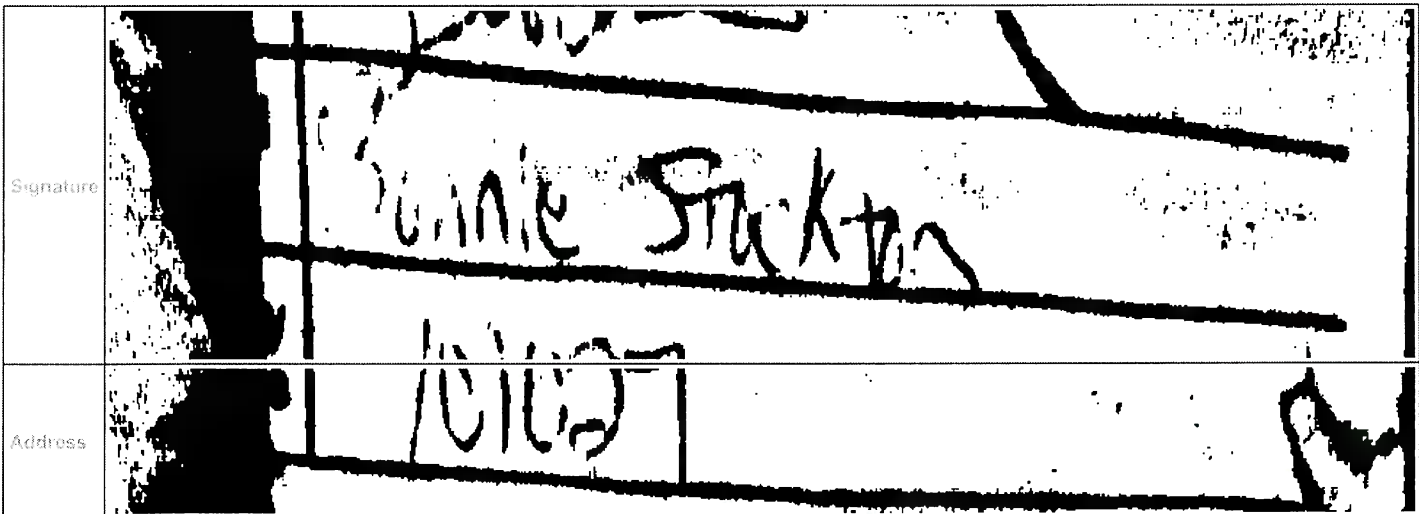

Enter up to 35 items separated by commas.

Select Search Type:

Quick Search



Submit

Product Tracking & Reporting, All Rights Reserved

Version: 26.2.1-9f61da1e

[Help](#)



Product Tracking & Reporting

[Home](#)

[Search](#)

[Reports](#)

[Manual Entry](#)

[Rates/
Commitments](#)

[PTR / EDW](#)

[Customer
Information](#)

April 09, 2026

USPS Tracking Intranet

Delivery Signature and Address



1. Do not share information from this site outside of USPS. It is intended for USPS employee use only.
2. Employees may see some items with only event MT in the tracking record. This is an indication that the tracking number was part of problem where the USPS Label Creation API created the same label number multiple times. This led to a confusing tracking experience, so tracking has been suppressed. Reference this ticket for more info: INC000010539853.

Tracking Number: 9414 8149 0236 8957 9359 17

This item was delivered on 03/06/2026 at 09:09:00

[< Return to Tracking Number View](#)

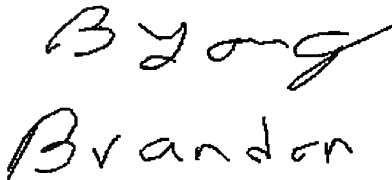
Signature	
Address	<p>PO BOX 1037</p> <p>OKMULGEE, OK 74447-1037</p>

Enter up to 35 items separated by commas.

Select Search Type:

Quick Search



Submit

Product Tracking & Reporting, All Rights Reserved
Version: 26.2.1-9f61da1e

[Help](#)



Product Tracking & Reporting

[Home](#)

[Search](#)

[Reports](#)

[Manual Entry](#)

[Rates/
Commitments](#)

[PTR / EDW](#)

[Customer
Information](#)

April 09, 2026

USPS Tracking Intranet

Delivery Signature and Address





1. Do not share information from this site outside of USPS. It is intended for USPS employee use only.
2. Employees may see some items with only event MT in the tracking record. This is an indication that the tracking number was part of problem where the USPS Label Creation API created the same label number multiple times. This led to a confusing tracking experience, so tracking has been suppressed. Reference this ticket for more info: INC000010539853.

Tracking Number: 9414 8149 0236 8957 9359 24

This item was delivered on 03/16/2026 at 10:05:00

[< Return to Tracking Number View](#)

Signature	 
Address	1713

Enter up to 35 items separated by commas.

Select Search Type:

Quick Search



Submit

Product Tracking & Reporting, All Rights Reserved
Version: 26.2.1-9f61da1e

[Help](#)



Product Tracking & Reporting

[Home](#)

[Search](#)

[Reports](#)

[Manual Entry](#)

[Rates/
Commitments](#)

[PTR / EDW](#)

[Customer
Information](#)

April 09, 2026

USPS Tracking Intranet

Delivery Signature and Address





1. Do not share information from this site outside of USPS. It is intended for USPS employee use only.
2. Employees may see some items with only event MT in the tracking record. This is an indication that the tracking number was part of problem where the USPS Label Creation API created the same label number multiple times. This led to a confusing tracking experience, so tracking has been suppressed. Reference this ticket for more info: INC000010539853.

Tracking Number: 9414 8149 0236 8957 9359 31

This item was delivered on 03/16/2026 at 10:05:00

[< Return to Tracking Number View](#)

Signature	 
Address	1313

Enter up to 35 items separated by commas.

Select Search Type:

Quick Search



Submit

Product Tracking & Reporting, All Rights Reserved
Version: 26.2.1-9f61da1e

Help



Product Tracking & Reporting

Home

Search

Reports

Manual Entry

Rates/
Commitments

PTR / EDW

Customer
Information

April 09, 2026

USPS Tracking Intranet

Delivery Signature and Address



- 1. Do not share information from this site outside of USPS. It is intended for USPS employee use only.
- 2. Employees may see some items with only event MT in the tracking record. This is an indication that the tracking number was part of problem where the USPS Label Creation API created the same label number multiple times. This led to a confusing tracking experience, so tracking has been suppressed. Reference this ticket for more info: INC000010539853.

Tracking Number: 9414 8149 0236 8957 9359 48

This item was delivered on 03/12/2026 at 10:35:00

[< Return to Tracking Number View](#)

Signature	 NICK ANTONSO
Address	PO Box 1342 Sabinal, TX 78881

Enter up to 35 items separated by commas.

Select Search Type:

Quick Search



Submit

Product Tracking & Reporting, All Rights Reserved
Version: 26.2.1-9f61da1e

Product Tracking & Reporting



Home Search Alerts Manual Entry Data Management Reports Information Help

USPS Tracking Intranet

Delivery Signature and Address

1. Do not share information from this site outside of USPS. It is intended for USPS employee use only.

2. Employees may see some items with only event MT in the tracking record. This is an indication that the tracking number was part of a problem where the USPS Label Creation API created the same label number multiple times. This led to a confusing tracking experience, so tracking has been suppressed. Reference this ticket for more info: INCO00010538853.

Tracking Number: 9414 8149 0236 8957 9359 55

This item was delivered on 03/06/2026 at 06:52:00

[Return to Tracking Number View](#)

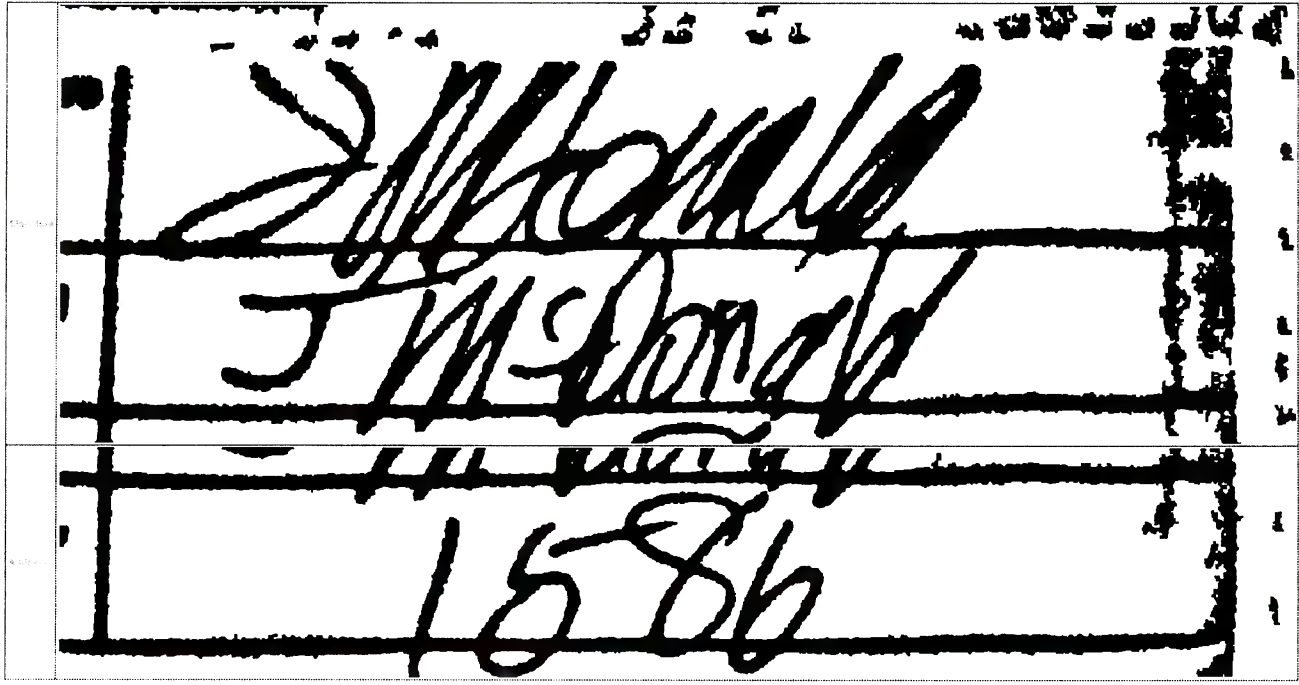

Enter up to 35 items separated by commas.

Select Search Type Quick Search

Product Tracking & Reporting, All Rights Reserved
Version: 26.2.1-9/6/1da1e

[Help](#)



Product Tracking & Reporting

[Home](#)

[Search](#)

[Reports](#)

[Manual Entry](#)

[Rates/
Commitments](#)

[PTR / EDW](#)

[Customer
Information](#)

April 09, 2026

USPS Tracking Intranet

Delivery Signature and Address



1. Do not share information from this site outside of USPS. It is intended for USPS employee use only.
2. Employees may see some items with only event MT in the tracking record. This is an indication that the tracking number was part of problem where the USPS Label Creation API created the same label number multiple times. This led to a confusing tracking experience, so tracking has been suppressed. Reference this ticket for more info: INC000010539853.

Tracking Number: 9414 8149 0236 8957 9359 62

This item was delivered on 03/09/2026 at 07:58:00

[< Return to Tracking Number View](#)

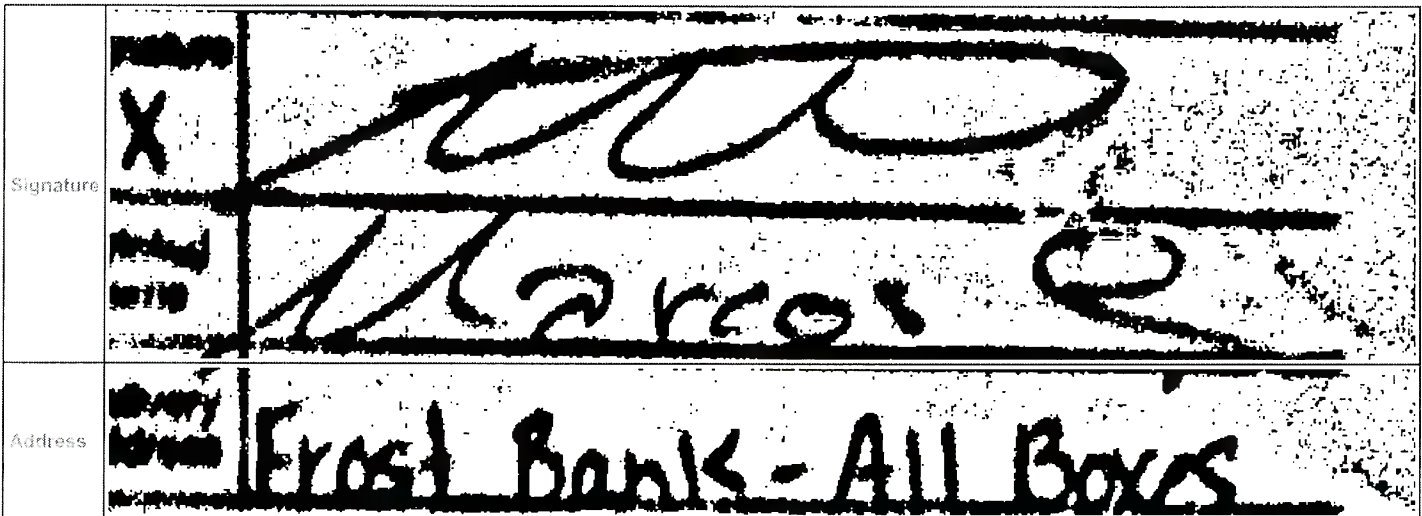

Enter up to 35 items separated by commas.

Select Search Type:

Quick Search



Submit

Product Tracking & Reporting, All Rights Reserved

Version: 26.2.1-9f61da1e

[Help](#)



Product Tracking & Reporting

[Home](#)

[Search](#)

[Reports](#)

[Manual Entry](#)

[Rates/
Commitments](#)

[PTR / EDW](#)

[Customer
Information](#)

Apr 10 2026

USPS Tracking Intranet

Delivery Signature and Address





1. Do not share information from this site outside of USPS. It is intended for USPS employee use only.
2. Employees may see some items with only event MT in the tracking record. This is an indication that the tracking number was part of problem where the USPS Label Creation API created the same label number multiple times. This led to a confusing tracking experience, so tracking has been suppressed. Reference this ticket for more info: INC000010539853.

Tracking Number: 9414 8149 0236 8957 9359 79

This item was delivered on 03/10/2026 at 12:33:00

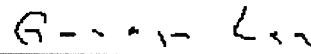
[< Return to Tracking Number View](#)

Signature	 
Address	

Enter up to 35 items separated by commas.

Select Search Type:

Quick Search



Submit

Product Tracking & Reporting, All Rights Reserved
Version: 26.2.1-9f61da1e

[Help](#)



Product Tracking & Reporting

[Home](#)

[Search](#)

[Reports](#)

[Manual Entry](#)

[Rates/
Commitments](#)

[PTR / EDW](#)

[Customer
Information](#)

April 09, 2026

USPS Tracking Intranet

Delivery Signature and Address



1. Do not share information from this site outside of USPS. It is intended for USPS employee use only.
2. Employees may see some items with only event MT in the tracking record. This is an indication that the tracking number was part of problem where the USPS Label Creation API created the same label number multiple times. This led to a confusing tracking experience, so tracking has been suppressed. Reference this ticket for more info: INC000010539853.

Tracking Number: 9414 8149 0236 8957 9359 86

This item was delivered on 03/12/2026 at 14:29:00

[< Return to Tracking Number View](#)

Signature	
Address	<p>PO BOX 2035</p> <p>ROSWELL, NM 88202-2035</p>

Enter up to 35 items separated by commas.

Select Search Type:

Quick Search



Submit

Product Tracking & Reporting, All Rights Reserved

Version: 26.2.1-9f61da1e

[Help](#)



Product Tracking & Reporting

[Home](#)

[Search](#)

[Reports](#)

[Manual Entry](#)

[Rates/
Commitments](#)

[PTR / EDW](#)

[Customer
Information](#)

April 09, 2026

USPS Tracking Intranet

Delivery Signature and Address



1. Do not share information from this site outside of USPS. It is intended for USPS employee use only.
2. Employees may see some items with only event MT in the tracking record. This is an indication that the tracking number was part of problem where the USPS Label Creation API created the same label number multiple times. This led to a confusing tracking experience, so tracking has been suppressed. Reference this ticket for more info: INC000010539853.

Tracking Number: 9414 8149 0236 8957 9359 93

This item was delivered on 03/06/2026 at 10:08:00

[< Return to Tracking Number View](#)

Signature	
Address	

Enter up to 35 items separated by commas.

Select Search Type:

Quick Search



Submit

Product Tracking & Reporting, All Rights Reserved

Version: 26.2.1-9f61da1e

[Help](#)



Product Tracking & Reporting

[Home](#)

[Search](#)

[Reports](#)

[Manual Entry](#)

[Rates/
Commitments](#)

[PTR / EDW](#)

[Customer
Information](#)

April 09, 2026

USPS Tracking Intranet

Delivery Signature and Address



- 1. Do not share information from this site outside of USPS. It is intended for USPS employee use only.
- 2. Employees may see some items with only event MT in the tracking record. This is an indication that the tracking number was part of problem where the USPS Label Creation API created the same label number multiple times. This led to a confusing tracking experience, so tracking has been suppressed. Reference this ticket for more info: INC000010539853.

Tracking Number: 9414 8149 0236 8957 9360 06

This item was delivered on 03/06/2026 at 10:08:00

[< Return to Tracking Number View](#)

Signature	
Address	7292

Enter up to 35 items separated by commas.

Select Search Type:

Quick Search



Submit

Product Tracking & Reporting, All Rights Reserved

Version: 26.2.1-9f61da1e

[Help](#)



Product Tracking & Reporting

[Home](#)

[Search](#)

[Reports](#)

[Manual Entry](#)

[Rates/
Commitments](#)

[PTR / EDW](#)

[Customer
Information](#)

April 09, 2026

USPS Tracking Intranet

Delivery Signature and Address



1. Do not share information from this site outside of USPS. It is intended for USPS employee use only.
2. Employees may see some items with only event MT in the tracking record. This is an indication that the tracking number was part of problem where the USPS Label Creation API created the same label number multiple times. This led to a confusing tracking experience, so tracking has been suppressed. Reference this ticket for more info: INC000010539853.

Tracking Number: 9414 8149 0236 8957 9360 13

This item was delivered on 03/07/2026 at 07:58:00

[< Return to Tracking Number View](#)

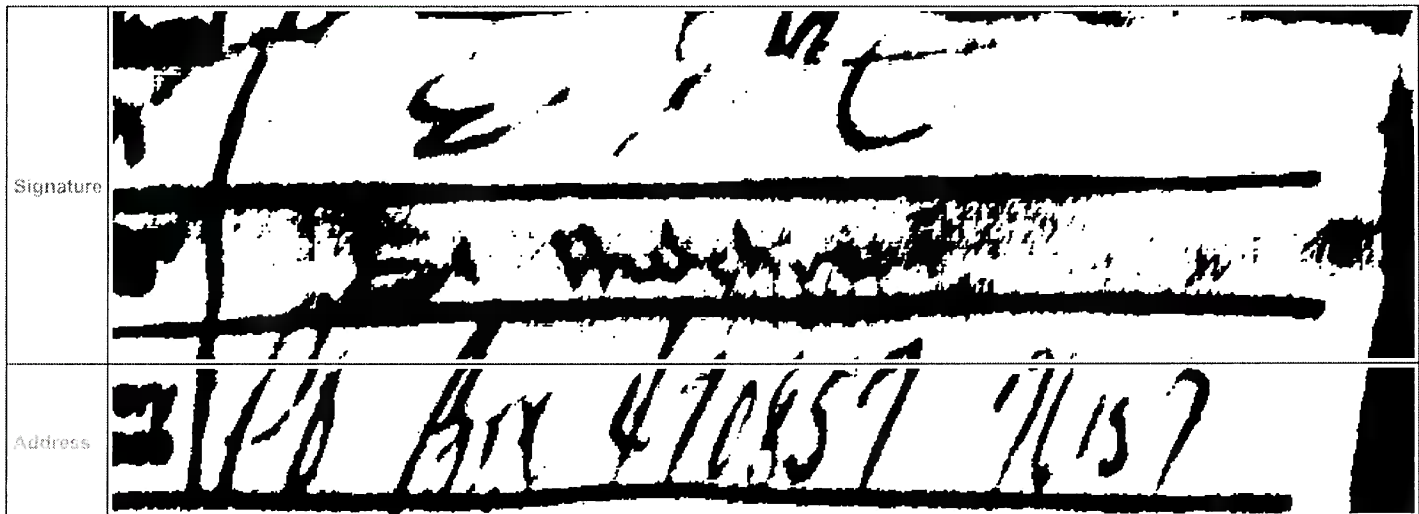

Enter up to 35 items separated by commas.

Select Search Type:

Quick Search



Submit

Product Tracking & Reporting, All Rights Reserved

Version: 26.2.1-9f61da1e

[Help](#)



Product Tracking & Reporting

[Home](#)

[Search](#)

[Reports](#)

[Manual Entry](#)

[Rates/
Commitments](#)

[PTR / EDW](#)

[Customer
Information](#)

April 09, 2026

USPS Tracking Intranet

Delivery Signature and Address



1. Do not share information from this site outside of USPS. It is intended for USPS employee use only.
2. Employees may see some items with only event MT in the tracking record. This is an indication that the tracking number was part of problem where the USPS Label Creation API created the same label number multiple times. This led to a confusing tracking experience, so tracking has been suppressed. Reference this ticket for more info: INC000010539853.

Tracking Number: 9414 8149 0236 8957 9360 20

This item was delivered on 03/11/2026 at 10:01:00

[< Return to Tracking Number View](#)

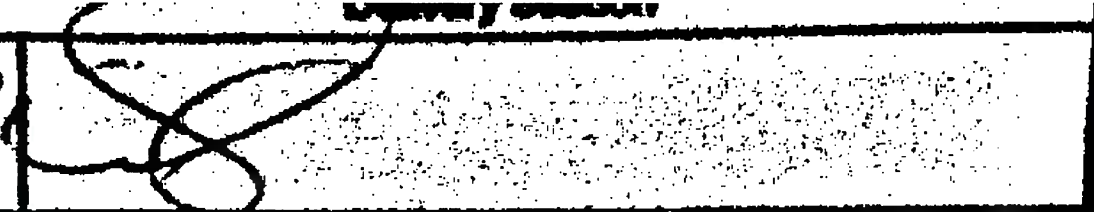
Signature	
	Printed Name Candy Copeland
Address	Delivery Address 50187

Enter up to 35 items separated by commas.

Select Search Type:

Quick Search

Product Tracking & Reporting, All Rights Reserved

Version: 26.2.1-9f61da1e

Help



Product Tracking & Reporting

Home

Search

Reports

Manual Entry

Rates/
Commitments

PTR / EDW

Customer
Information

April 09, 2026

USPS Tracking Intranet

Delivery Signature and Address



1. Do not share information from this site outside of USPS. It is intended for USPS employee use only.
2. Employees may see some items with only event MT in the tracking record. This is an indication that the tracking number was part of problem where the USPS Label Creation API created the same label number multiple times. This led to a confusing tracking experience, so tracking has been suppressed. Reference this ticket for more info: INC000010539853.

Tracking Number: 9414 8149 0236 8957 9360 37

This item was delivered on 03/04/2026 at 10:37:00

[< Return to Tracking Number View](#)

Signature	Signature X	B Rimerca
	Printed Name	B RIMERCA
Address	Delivery Address	50880

Enter up to 35 items separated by commas.

Select Search Type:

Quick Search



Submit

Product Tracking & Reporting, All Rights Reserved

Version: 26.2.1-9f61da1e

[Help](#)



Product Tracking & Reporting

[Home](#)

[Search](#)

[Reports](#)

[Manual Entry](#)

[Rates/
Commitments](#)

[PTR / EDW](#)

[Customer
Information](#)

April 09 2026

USPS Tracking Intranet

Delivery Signature and Address



1. Do not share information from this site outside of USPS. It is intended for USPS employee use only.
2. Employees may see some items with only event MT in the tracking record. This is an indication that the tracking number was part of problem where the USPS Label Creation API created the same label number multiple times. This led to a confusing tracking experience, so tracking has been suppressed. Reference this ticket for more info: INC000010539853.

Tracking Number: 9414 8149 0236 8957 9360 44

This item was delivered on 03/05/2026 at 11:43:00

[< Return to Tracking Number View](#)

Delivery Section					
Signature	<table border="1"> <tr> <td>Signature X</td> <td></td> </tr> <tr> <td>Printed Name</td> <td>Robert Hortera</td> </tr> </table>	Signature X		Printed Name	Robert Hortera
Signature X					
Printed Name	Robert Hortera				
Address	Delivery Address				

Enter up to 35 items separated by commas.

Select Search Type:

Quick Search

Product Tracking & Reporting, All Rights Reserved
Version: 26.2.1-9f61da1e

[Help](#)



Product Tracking & Reporting

[Home](#)

[Search](#)

[Reports](#)

[Manual Entry](#)

[Rates/
Commitments](#)

[PTR / EDW](#)

[Customer
Information](#)

April 09, 2026

USPS Tracking Intranet

Delivery Signature and Address





1. Do not share information from this site outside of USPS. It is intended for USPS employee use only.
2. Employees may see some items with only event MT in the tracking record. This is an indication that the tracking number was part of problem where the USPS Label Creation API created the same label number multiple times. This led to a confusing tracking experience, so tracking has been suppressed. Reference this ticket for more info: INC000010539853.

Tracking Number: 9414 8149 0236 8957 9360 51

This item was delivered on 03/14/2026 at 16:15:00

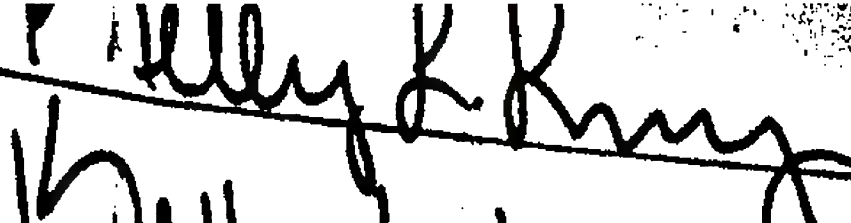
[< Return to Tracking Number View](#)

Signature	
Delivery Address	
Address	

Enter up to 35 items separated by commas.

Select Search Type:

Quick Search

Product Tracking & Reporting, All Rights Reserved

Version: 26.2.1-9f61da1e

[Help](#)



Product Tracking & Reporting

[Home](#)

[Search](#)

[Reports](#)

[Manual Entry](#)

[Rates/
Commitments](#)

[PTR / EDW](#)

[Customer
Information](#)

Apr 1 09, 2026

USPS Tracking Intranet

Delivery Signature and Address



1. Do not share information from this site outside of USPS. It is intended for USPS employee use only.
2. Employees may see some items with only event MT in the tracking record. This is an indication that the tracking number was part of problem where the USPS Label Creation API created the same label number multiple times. This led to a confusing tracking experience, so tracking has been suppressed. Reference this ticket for more info: INC000010539853.

Tracking Number: 9414 8149 0236 8957 9360 68

This item was delivered on 03/08/2026 at 06:47:00

[< Return to Tracking Number View](#)

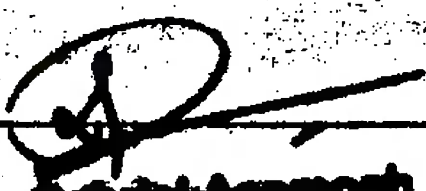
Signature	Signature X	Delivery Section 
	Printed Name [Illegible]	
Address	Delivery Address	

Enter up to 35 items separated by commas.

Select Search Type:

Product Tracking & Reporting, All Rights Reserved
Version: 26.2.1-9f61da1e

Help



Product Tracking & Reporting

Home

Search

Reports

Manual Entry

Rates/
Commitments

PTR / EDW

Customer
Information

April 09, 2026

USPS Tracking Intranet

Delivery Signature and Address



1. Do not share information from this site outside of USPS. It is intended for USPS employee use only.
2. Employees may see some items with only event MT in the tracking record. This is an indication that the tracking number was part of problem where the USPS Label Creation API created the same label number multiple times. This led to a confusing tracking experience, so tracking has been suppressed. Reference this ticket for more info: INC000010539853.

Tracking Number: 9414 8149 0236 8957 9360 75

This item was delivered on 03/08/2026 at 06:47:00

[< Return to Tracking Number View](#)

Delivery Section					
Signature	<table border="1"> <tr> <td>Signature</td> <td>X</td> </tr> <tr> <td>Printed Name</td> <td><i>[Handwritten Signature]</i></td> </tr> </table>	Signature	X	Printed Name	<i>[Handwritten Signature]</i>
Signature	X				
Printed Name	<i>[Handwritten Signature]</i>				
Address	<table border="1"> <tr> <td>Delivery Address</td> <td></td> </tr> </table>	Delivery Address			
Delivery Address					

Enter up to 35 items separated by commas.

Select Search Type:

Quick Search

Product Tracking & Reporting, All Rights Reserved
Version: 26.2.1-9f61da1e

[Help](#)



Product Tracking & Reporting

Home Search Reports Manual Entry Rates/Commitments PTR / EDW Customer information April 09, 2026

USPS Tracking Intranet

Delivery Signature and Address



- 1. Do not share information from this site outside of USPS. It is intended for USPS employee use only.
- 2. Employees may see some items with only event MT in the tracking record. This is an indication that the tracking number was part of problem where the USPS Label Creation API created the same label number multiple times. This led to a confusing tracking experience, so tracking has been suppressed. Reference this ticket for more info: INC000010539853.

Tracking Number: 9414 8149 0236 8957 9360 82

This item was delivered on 03/08/2026 at 06:42:00

[< Return to Tracking Number View](#)

Delivery Section	
Signature	<p>Signature</p> <p>X </p>
Printed Name	<p>Printed Name</p> <p>KISSER BAKER</p>
Address	<p>Delivery Address</p> <p>K. BAKER</p>

Enter up to 35 items separated by commas.

Select Search Type:

Quick Search

Product Tracking & Reporting, All Rights Reserved
Version: 26.2.1-9f61da1e

Help



Product Tracking & Reporting

Home

Search

Reports

Manual Entry

Rates/
Commitments

PTR / EDW

Customer
Information

April 09, 2026

USPS Tracking Intranet

Delivery Signature and Address



1. Do not share information from this site outside of USPS. It is intended for USPS employee use only.
2. Employees may see some items with only event MT in the tracking record. This is an indication that the tracking number was part of problem where the USPS Label Creation API created the same label number multiple times. This led to a confusing tracking experience, so tracking has been suppressed. Reference this ticket for more info: INC000010539853.

Tracking Number: 9414 8149 0236 8957 9360 99

This item was delivered on 03/09/2026 at 04:34:00

[< Return to Tracking Number View](#)

	Delivery Section	
Signature	Signature	
	Printed Name	Isaac Anjo-ech
Address	Delivery Address	74191 - 74199 - 74198

Enter up to 35 items separated by commas.

Select Search Type:

Quick Search

Product Tracking & Reporting, All Rights Reserved
Version: 26.2.1-9f61da1e

Help



Product Tracking & Reporting

Home

Search

Reports

Manual Entry

Rates/
Commitments

PTR / EDW

Customer
Information

April 09, 2026

USPS Tracking Intranet

Delivery Signature and Address



- 1. Do not share information from this site outside of USPS. It is intended for USPS employee use only.
- 2. Employees may see some items with only event MT in the tracking record. This is an indication that the tracking number was part of problem where the USPS Label Creation API created the same label number multiple times. This led to a confusing tracking experience, so tracking has been suppressed. Reference this ticket for more info: INC000010539853.

Tracking Number: 9414 8149 0236 8957 9361 05

This item was delivered on 03/09/2026 at 04:34:00

[< Return to Tracking Number View](#)

	Delivery Section	
Signature	Signature	
	Printed Name	Heidi Anderson
Address	Delivery Address	74191 - 74199 - 74198

Enter up to 35 items separated by commas.

Select Search Type:

Quick Search



Submit

Product Tracking & Reporting, All Rights Reserved

Version: 26.2.1-9f61da1e

From: [Florez, Marie E](#)
To: [Clelland, Sarah, EMNRD](#)
Subject: RE: [EXTERNAL] RE: Action ID 560258 PLC-649-B
Date: Thursday, April 9, 2026 3:18:25 PM
Attachments: [James Ranch Unit DI 11 NMOCD commingle application 20260409.pdf](#)

See attached: corrected pool

Marie E. Florez

Regulatory Analyst
Permian Basin – Delaware Operations

ExxonMobil Upstream Company
A division of Exxon Mobil Corporation
3617 North Big Spring Street
Midland, TX 79707

505-419-8420 cell
432-894-4949 cell
Marie.florez@exxonmobil.com

From: Clelland, Sarah, EMNRD <Sarah.Clelland@emnrd.nm.gov>
Sent: Thursday, April 9, 2026 1:22 PM
To: Florez, Marie E <marie.florez@exxonmobil.com>
Subject: RE: [EXTERNAL] RE: Action ID 560258 PLC-649-B

Try to get this into me today before 4. If you can do that I can get it in for signature and you will have the order early next week.

Thanks,

Sarah Clelland

Petroleum Specialist
State of New Mexico
Energy, Minerals, and Natural Resources Department
Oil Conservation Division
Cell: (505) 537-0627
Sarah.Clelland@emnrd.nm.gov

From: Florez, Marie E <marie.florez@exxonmobil.com>
Sent: Thursday, April 9, 2026 11:59 AM

To: Clelland, Sarah, EMNRD <Sarah.Clelland@emnrd.nm.gov>

Subject: [EXTERNAL] RE: Action ID 560258 PLC-649-B

CAUTION: This email originated outside of our organization. Exercise caution prior to clicking on links or opening attachments.

Hi Sarah,

I fixed the pool code to 97905.

I'm waiting for the corrected receipt numbers from USPS. An error occurred on USPS side.

Thanks

Marie E. Florez

Regulatory Analyst

Permian Basin – Delaware Operations

ExxonMobil Upstream Company

A division of Exxon Mobil Corporation

3617 North Big Spring Street

Midland, TX 79707

505-419-8420 cell

432-894-4949 cell

Marie.florez@exxonmobil.com

From: Clelland, Sarah, EMNRD <Sarah.Clelland@emnrd.nm.gov>

Sent: Tuesday, April 7, 2026 12:30 PM

To: Florez, Marie E <marie.florez@exxonmobil.com>

Subject: Action ID 560258 PLC-649-B

To whom it may concern (c/o Marie Florez for XTO Permian Operating, LLC),

The Division is reviewing the following application:

Action ID	560258
Admin No.	PLC-649-B
Applicant	XTO Permian Operating, LLC
Title	James Ranch Unit DI 11 Battery
Sub. Date	03/05/2026

Please provide the following additional supplemental documents:

- API 30-015-46283 on application shows Pool Code 96597. In all completion sundries and well details it has Pool Code 97905. Please verify which is accurate, If 97905 is accurate please change application accordingly and resubmit entire application as PDF attached to this returned email.
- Please verify all certified mailing receipt numbers. They all show as invalid.

Please provide additional information regarding the following:

-

Additional notes:

-

All additional supplemental documents and information may be provided via email and should be done by replying to this email. The produced email chain will be uploaded to the file for this application.

Please note that failure to take steps to address each of the requests made in this email within 10 business days of receipt of this email may result in the Division rejecting the application requiring the submittal of a new application by the applicant once it is prepared to address each of the topics raised.

COMMENT

Approval from Division is required prior to conducting work which modifies the well design.

Please contact the Environmental Bureau at OCD.Enviro@emnrd.nm.gov for instructions regarding the submittal process for applications of this type.

Thanks,

Sarah Clelland

Petroleum Specialist

State of New Mexico

Energy, Minerals, and Natural Resources Department

Oil Conservation Division

Cell: (505) 537-0627

Sarah.Clelland@emnrd.nm.gov

**STATE OF NEW MEXICO
ENERGY, MINERALS AND NATURAL RESOURCES DEPARTMENT
OIL CONSERVATION DIVISION**

**APPLICATION FOR SURFACE COMMINGLING
SUBMITTED BY XTO PERMIAN OPERATING, LLC**

ORDER NO. PLC-649-B

ORDER

The Director of the New Mexico Oil Conservation Division (“OCD”), having considered the application and the recommendation of the OCD Engineering Bureau, issues the following Order.

FINDINGS OF FACT

1. XTO Permian Operating, LLC (“Applicant”) submitted a complete application to surface commingle the oil and gas production from the pools and leases described in Exhibit A (“Application”).
2. Applicant included a complete list of the wells currently dedicated to each pool and lease.
3. Applicant proposed a method to allocate the oil and gas production to the pools, leases, and wells to be commingled.
4. Applicant stated that it intends to keep the oil and gas production from one or more group(s) of wells identified in Exhibit B segregated from the oil and gas production from all other wells prior to measuring that production with an allocation meter.
5. Applicant certified the commingling of oil and gas production from the pools, leases, and wells will not in reasonable probability reduce the value of the oil and gas production to less than if it had remained segregated.
6. Applicant in the notice for the Application stated that it sought authorization to prospectively include additional pools and leases in accordance with 19.15.12.10(C)(4)(g) NMAC.
7. Applicant stated that it sought authorization to surface commingle and off-lease measure, as applicable, oil and gas production from wells which have not yet been approved to be drilled, but will produce from a pool and lease as described in Exhibit A.
8. Applicant provided notice of the Application to all persons owning an interest in the oil and gas production to be commingled, including the owners of royalty and overriding royalty interests, regardless of whether they have a right or option to take their interests in kind, and those persons either submitted a written waiver or did not file an objection to the Application.
9. Applicant provided notice of the Application to the Bureau of Land Management (“BLM”) or New Mexico State Land Office (“NMSLO”), as applicable.

CONCLUSIONS OF LAW

10. OCD has jurisdiction to issue this Order pursuant to the Oil and Gas Act, NMSA 1978, §§ 70-2-6, 70-2-11, 70-2-12, 70-2-16, and 70-2-17, 19.15.12. NMAC, and 19.15.23. NMAC.
11. Applicant satisfied the notice requirements for the Application in accordance with 19.15.12.10(A)(2) NMAC, 19.15.12.10(C)(4)(c) NMAC, and 19.15.12.10(C)(4)(e) NMAC, as applicable.
12. Applicant satisfied the notice requirements for the Application in accordance with 19.15.23.9(A)(5) NMAC and 19.15.23.9(A)(6) NMAC, as applicable.
13. Applicant's proposed method of allocation, as modified herein, complies with 19.15.12.10(B)(1) NMAC or 19.15.12.10(C)(1) NMAC, as applicable.
14. Commingling of oil and gas production from state, federal, or tribal leases shall not commence until approved by the BLM or NMSLO, as applicable, in accordance with 19.15.12.10(B)(3) NMAC and 19.15.12.10(C)(4)(h) NMAC.
15. Applicant satisfied the notice requirements for the subsequent addition of pools, leases, and wells in the notice for the Application, in accordance with 19.15.12.10(C)(4)(g) NMAC. Subsequent additions of pools, leases, and wells within Applicant's defined parameters, as modified herein, will not, in reasonable probability, reduce the commingled production's value or otherwise adversely affect the interest owners in the production to be added.
16. By granting the Application with the conditions specified below, this Order prevents waste and protects correlative rights, public health, and the environment.

ORDER

1. Applicant is authorized to surface commingle oil and gas production from the pools and leases as described in Exhibit A.

Applicant is authorized to surface commingle oil and gas production from the wells included in Exhibit A provided that they produce from a pool and lease described in Exhibit A.

Applicant is authorized to store and measure oil and gas production off-lease, as applicable, from the pools and leases as described in Exhibit A at a central tank battery or gas title transfer meter described in Exhibit A.

Applicant is authorized to surface commingle oil and gas production from wells not included in Exhibit A but that produce from a pool and lease as described in Exhibit A.

Applicant is authorized to store and measure oil and gas production off-lease, as applicable, from wells not included in Exhibit A but that produce from a pool and lease as described in Exhibit A at a central tank battery or gas title transfer meter described in Exhibit A.

2. This Order supersedes Order PLC-649-A.

3. The allocation of oil and gas production to wells not included in Exhibit A but that produce from a pool and lease as described in Exhibit A shall be determined in the same manner as to wells identified in Exhibit A that produce from that pool and lease, provided that if more than one allocation method is being used or if there are no wells identified in Exhibit A that produce from the pool and lease, then allocation of oil and gas production to each well not included in Exhibit A shall be determined by OCD prior to commingling production from it with the production from another well.
4. The allocation of oil and gas production to each group of wells identified in Exhibit B shall be determined by separating and metering the production from each group as described by Train in Exhibit B prior to commingling that production with production from any other well.
5. The allocation of oil and gas production shall be based on the production life of each well as measured for three periods:

- a. The initial production period shall be measured from the first production until the earlier of either the peak production rate or thirty (30) days after the first production.

During the initial production period, the oil and gas production for each well identified in Exhibit A shall be allocated using a production curve calculated from a minimum of ten (10) well tests per month, except that any day in which a well test cannot achieve an accurate result due to a temporary change in oil and gas production shall not be included in the computation of time determining the well test schedule. The production curve shall be calculated by interpolating daily production for each day using the known daily production obtained by well tests and shall use a method of interpolation that is at minimum as accurate as maintaining a constant rate of change for each day's production between the known daily production values.

- b. The plateau period shall be measured from the end of the initial production period to the peak decline rate.

During the plateau period, the oil and gas production for each well identified in Exhibit A shall be allocated using a minimum of three (3) well tests per month.

- c. The decline period shall be measured from the end of the plateau period until the well is plugged and abandoned.

During the decline period, the oil and gas production for each well identified in Exhibit A shall be allocated as follows:

- i. a minimum of three (3) well tests per month when the decline rate is greater than twenty-two percent (22%) per month;
- ii. a minimum of two (2) well tests per month when the decline rate is between twenty-two percent (22%) and ten percent (10%) per month; and

- iii. a minimum of one (1) well test per month when the decline rate is less than ten percent (10%) per month.

Upon OCD's request, Applicant shall submit a Form C-103 to the OCD Engineering Bureau that contains the decline rate curve and other relevant information demonstrating the production life of a well.

Applicant shall conduct a well test by separating and metering the oil and gas production from that well for either:

- a. a minimum of twenty-four (24) consecutive hours; or
- b. a combination of nonconsecutive periods that meet the following conditions:
 - i. Each period shall be a minimum of six (6) hours.
 - ii. The total duration of the nonconsecutive periods shall be a minimum of eighteen (18) hours.
 - iii. A vessel shall be allowed to reach equilibrium and a sufficient liquid retention time for accurate measurement achieved prior to beginning the well test.

The well test requirements of this Order shall be suspended for any well shut-in for a period that continues for more than fifteen (15) days until the well commences production.

6. If Applicant recovers oil or gas production from produced water prior to Applicant injecting it or transferring custody of it, then that production shall be allocated to each well in the proportion that it contributed to the total produced water.
7. If Applicant recovers gas production using a vapor recovery unit (VRU), then that gas production shall be allocated to each well in the proportion that it contributed to the total oil production.
8. Applicant shall measure and market the commingled oil at a central tank battery described in Exhibit A in accordance with this Order and 19.15.18.15 NMAC or 19.15.23.8 NMAC.
9. Applicant shall measure and market the commingled gas at a well pad, central delivery point, central tank battery, or gas title transfer meter described in Exhibit A in accordance with this Order and 19.15.19.9 NMAC, provided however that if the gas is vented or flared, and regardless of the reason or authorization pursuant to 19.15.28.8(B) NMAC for such venting or flaring, Applicant shall measure or estimate the gas in accordance with 19.15.28.8(E) NMAC.
10. Applicant shall calibrate the meters used to measure or allocate oil and gas production in accordance with 19.15.12.10(C)(2) NMAC.
11. Applicant shall install and utilize vessels that are appropriately designed to ensure sufficient separation of the fluids and to accurately measure oil and gas production.

- 12. If the commingling of oil and gas production from any pool, lease, or well reduces the value of the commingled oil and gas production to less than if it had remained segregated, no later than sixty (60) days after the decrease in value has occurred Applicant shall submit a new surface commingling application to OCD to amend this Order to remove the pool, lease, or well whose oil and gas production caused the decrease in value. If Applicant fails to submit a new application, this Order shall terminate on the following day, and if OCD denies the application, this Order shall terminate on the date of such action.
- 13. Applicant may submit an application to amend this Order to add pools, leases, and subsequently drilled wells with spacing units adjacent to or within the tracts commingled by this Order by submitting a Form C-107-B in accordance with 19.15.12.10(C)(4)(g) NMAC, provided the pools, leases, and subsequently drilled wells are within the identified parameters included in the Application.
- 14. If a well is not included in Exhibit A but produces from a pool and lease as described in Exhibit A, then Applicant shall submit Forms C-102 and C-103 to the OCD Engineering Bureau after the well has been approved to be drilled and prior to off-lease measuring or commingling oil or gas production from it with the production from another well. The Form C-103 shall reference this Order and identify the well, proposed method to determine the allocation of oil and gas production to it, and the location(s) that commingling of its production will occur.
- 15. Applicant shall not commence commingling oil or gas production from state, federal, or tribal leases until approved by the BLM or NMSLO, as applicable.
- 16. If OCD determines that Applicant has failed to comply with any provision of this Order, OCD may take any action authorized by the Oil and Gas Act or the New Mexico Administrative Code (NMAC).
- 17. OCD retains jurisdiction of this matter and reserves the right to modify or revoke this Order as it deems necessary.

**STATE OF NEW MEXICO
OIL CONSERVATION DIVISION**

Albert Chang

**ALBERT C. S. CHANG
DIRECTOR**

DATE: 04/10/2026

State of New Mexico
Energy, Minerals and Natural Resources Department

Exhibit A

Order: PLC-649-B

Operator: XTO Permian Operating, LLC (373075)

Central Tank Battery: James Ranch Unit DI 11 Battery MAIN
 Central Tank Battery Location: UL I and J, Section 17, Township 22 South, Range 30 East x3
 Central Tank Battery: James Ranch Unit DI 11 Well Pad #1 Train A
 Central Tank Battery Location: UL K, Section 17, Township 22 South, Range 30 East
 Central Tank Battery: James Ranch Unit DI 11 Well Pad #3 Train B
 Central Tank Battery Location: UL K, Section 17, Township 22 South, Range 30 East
 Central Tank Battery: James Ranch Unit DI 11 Well Pad #7 Train C
 Central Tank Battery Location: UL J, Section 17, Township 22 South, Range 30 East
 Central Tank Battery: James Ranch Unit DI 11 Well Pad #8 Train D
 Central Tank Battery Location: UL J, Section 17, Township 22 South, Range 30 East
 Gas Title Transfer Meter Location: UL I and J, Section 17, Township 22 South, Range 30 East x2

Pools

Pool Name	Pool Code
LOS MEDANOS; WOLFCAMP, SOUTH	96336
LOS MEDANOS; WOLFCAMP (GAS)	96597
WILDCAT G-07 S223021G;BONE SPRING	97905
WC 015 G08 S223017 K WOLFCAMP	98344

Leases as defined in 19.15.12.7(C) NMAC

Lease	UL or Q/Q	S-T-R
PA Bone Spring NMNM 070965O	N2S2	13-22S-29E
	S2SW	14-22S-30E
	ALL	15-22S-30E
	ALL	16-22S-30E
	E2, SW4	17-22S-30E
	S2	18-22S-30E
	ALL	19-22S-30E
	ALL	20-22S-30E
	ALL	21-22S-30E
	ALL	22-22S-30E
	W2, S2SE	23-22S-30E
	S2S2	24-22S-30E
	ALL	26-22S-30E
	ALL	27-22S-30E
	E2	28-22S-30E
	N2NE, NENW	35-22S-30E
	ALL Minus UL E, M	36-22S-30E
	ALL	31-22S-31E
	W2W2	05-23S-31E
	ALL	06-23S-31E
	ALL	07-23S-31E
	W2	08-23S-31E
	NW4	17-23S-31E
	N2	18-23S-31E
PA Wolfcamp NMNM 070965L	N2S2	13-22S-29E
	ALL	15-22S-30E
	ALL	16-22S-30E
	E2, SW4	17-22S-30E
	S2	18-22S-30E
	ALL	19-22S-30E
	ALL	20-22S-30E
	ALL	21-22S-30E
	ALL	22-22S-30E
	W2	23-22S-30E
	ALL	26-22S-30E
	ALL	27-22S-30E
	E2	28-22S-30E
	N2NE, NENW, S2SE	35-22S-30E
	ALL Minus UL E, L	36-22S-30E
	ALL	31-22S-31E
	W2W2	05-23S-31E
	ALL	06-23S-31E
	ALL	07-23S-31E
	W2	08-23S-31E
	NW4	17-23S-31E
	N2	18-23S-31E

Wells					
Well API	Well Name	UL or Q/Q	S-T-R	Pool	
30-015-49038	JAMES RANCH UNIT DI 11 EKALAKA #821H	S2S2	15-22S-30E	97905	
		S2S2	16-22S-30E		
		S2SE	17-22S-30E		
30-015-49037	JAMES RANCH UNIT DI 11 EKALAKA U #822H	S2	15-22S-30E	97905	
		S2	16-22S-30E		
		SE4	17-22S-30E		
30-015-49036	JAMES RANCH UNIT DI 11 EKALAKA #823H	S2	15-22S-30E	97905	
		S2	16-22S-30E		
		SE4	17-22S-30E		
30-015-49033	JAMES RANCH UNIT DI 11 EKALAKA #824H	N2	15-22S-30E	97905	
		N2	16-22S-30E		
		NE4	17-22S-30E		
30-015-49032	JAMES RANCH UNIT DI 11 EKALAKA #923H	N2	15-22S-30E	97905	
		N2	16-22S-30E		
		NE4	17-22S-30E		
30-015-49039	JAMES RANCH UNIT DI 11 EKALAKA #921H	S2	15-22S-30E	97905	
		S2	16-22S-30E		
		SE4	17-22S-30E		
30-015-49035	JAMES RANCH UNIT DI 11 EKALAKA #922H	N2	15-22S-30E	97905	
		N2	16-22S-30E		
		NE4	17-22S-30E		
30-015-57276	JAMES RANCH UNIT DI 11 EKALAKA #701H	S2	15-22S-30E	97905	
		S2	16-22S-30E		
		SE4	17-22S-30E		
30-015-57277	JAMES RANCH UNIT DI 11 EKALAKA #702H	N2	15-22S-30E	97905	
		N2	16-22S-30E		
		NE4	17-22S-30E		
30-015-57280	JAMES RANCH UNIT DI 11 EKALAKA #703H	N2	15-22S-30E	97905	
		N2	16-22S-30E		
		NE4	17-22S-30E		
30-015-46284	JAMES RANCH UNIT DI 11 WHITLASH A #715H	N2S2	13-22S-29E	97905	
		N2SW	17-22S-30E		
		N2S2	18-22S-30E		
30-015-49040	JAMES RANCH UNIT DI 11 EKALAKA #121H	S2S2	15-22S-30E	96336	
		S2S2	16-22S-30E		
		S2SE	17-22S-30E		
30-015-46283	JRU DI 11 WHITLASH #515H	N2S2	13-22S-29E	97905	
		N2SW	17-22S-30E		
		N2S2	18-22S-30E		
30-015-49034	JAMES RANCH UNIT DI 11 EKALAKA #122H	S2	15-22S-30E	98344	
		S2	16-22S-30E		
		SE4	17-22S-30E		

30-015-49124	JAMES RANCH UNIT DI 11 EKALAKA #123H	N2	15-22S-30E	98344
		N2	16-22S-30E	
		NE4	17-22S-30E	
<hr/>				
30-015-46377	JAMES RANCH UNIT DI 11 WHITLASH #251H	N2S2	13-22S-29E	98344
		NWSW	17-22S-30E	
		N2S2	18-22S-30E	

State of New Mexico
Energy, Minerals and Natural Resources Department

Exhibit B

Order: PLC-649-B
Operator: XTO Permian Operating, LLC (373075)

Wells				
Well API	Well Name	UL or Q/Q	S-T-R	Train
30-015-46283	JRU DI 11 WHITLASH #515H	N2S2	13-22S-29E	A1
		N2SW	17-22S-30E	
		N2S2	18-22S-30E	
30-015-46284	JAMES RANCH UNIT DI 11 WHITLASH A #715H	N2S2	13-22S-29E	A1
		N2SW	17-22S-30E	
		N2S2	18-22S-30E	
30-015-46377	JAMES RANCH UNIT DI 11 WHITLASH #251H	N2S2	13-22S-29E	B1
		NWSW	17-22S-30E	
		N2S2	18-22S-30E	
30-015-49036	JAMES RANCH UNIT DI 11 EKALAKA #823H	S2	15-22S-30E	C1
		S2	16-22S-30E	
		SE4	17-22S-30E	
30-015-49037	JAMES RANCH UNIT DI 11 EKALAKA U #822H	S2	15-22S-30E	C1
		S2	16-22S-30E	
		SE4	17-22S-30E	
30-015-49038	JAMES RANCH UNIT DI 11 EKALAKA #821H	S2S2	15-22S-30E	C1
		S2S2	16-22S-30E	
		S2SE	17-22S-30E	
30-015-49039	JAMES RANCH UNIT DI 11 EKALAKA #921H	S2	15-22S-30E	C1
		S2	16-22S-30E	
		SE4	17-22S-30E	
30-015-49040	JAMES RANCH UNIT DI 11 EKALAKA #121H	S2S2	15-22S-30E	C1
		S2S2	16-22S-30E	
		S2SE	17-22S-30E	
30-015-49034	JAMES RANCH UNIT DI 11 EKALAKA #122H	S2	15-22S-30E	D1
		S2	16-22S-30E	
		SE4	17-22S-30E	
30-015-49035	JAMES RANCH UNIT DI 11 EKALAKA #922H	N2	15-22S-30E	D1
		N2	16-22S-30E	
		NE4	17-22S-30E	
30-015-49033	JAMES RANCH UNIT DI 11 EKALAKA #824H	N2	15-22S-30E	D1
		N2	16-22S-30E	
		NE4	17-22S-30E	
30-015-49124	JAMES RANCH UNIT DI 11 EKALAKA #123H	N2	15-22S-30E	D1
		N2	16-22S-30E	
		NE4	17-22S-30E	
30-015-49032	JAMES RANCH UNIT DI 11 EKALAKA #923H	N2	15-22S-30E	D1
		N2	16-22S-30E	
		NE4	17-22S-30E	

30-015-57276	JAMES RANCH UNIT DI 11 EKALAKA #701H	S2	15-22S-30E	D1
		S2	16-22S-30E	
		SE4	17-22S-30E	
30-015-57277	JAMES RANCH UNIT DI 11 EKALAKA #702H	N2	15-22S-30E	D1
		N2	16-22S-30E	
		NE4	17-22S-30E	
30-015-57280	JAMES RANCH UNIT DI 11 EKALAKA #703H	N2	15-22S-30E	D1
		N2	16-22S-30E	
		NE4	17-22S-30E	

Sante Fe Main Office
Phone: (505) 476-3441

General Information
Phone: (505) 629-6116

Online Phone Directory
<https://www.emnrd.nm.gov/ocd/contact-us>

State of New Mexico
Energy, Minerals and Natural Resources
Oil Conservation Division
1220 S. St Francis Dr.
Santa Fe, NM 87505

CONDITIONS

Action 560258

CONDITIONS

Operator: XTO PERMIAN OPERATING LLC. 3617 Big Spring St. MIDLAND, TX 79705	OGRID: 373075
	Action Number: 560258
	Action Type: [C-107] Surface Commingle or Off-Lease (C-107B)

CONDITIONS

Created By	Condition	Condition Date
sarah.clelland	Please review the content of the order to ensure you are familiar with the authorities granted and any conditions of approval. If you have any questions regarding this matter, please email us at OCD.Engineer@emnrd.nm.gov .	4/14/2026