

RECEIVED:	REVIEWER:	TYPE:	APP NO:
-----------	-----------	-------	---------

ABOVE THIS TABLE FOR OCD DIVISION USE ONLY

**NEW MEXICO OIL CONSERVATION DIVISION**  
 - Geological & Engineering Bureau -  
 1220 South St. Francis Drive, Santa Fe, NM 87505



**ADMINISTRATIVE APPLICATION CHECKLIST**

THIS CHECKLIST IS MANDATORY FOR ALL ADMINISTRATIVE APPLICATIONS FOR EXCEPTIONS TO DIVISION RULES AND REGULATIONS WHICH REQUIRE PROCESSING AT THE DIVISION LEVEL IN SANTA FE

**Applicant:** XTO Energy, Inc **OGRID Number:** 5380  
**Well Name:** Nash Unit - Multiple **API:** 30-015-Multiple  
**Pool:** Purple Sage; Wolfcamp (Gas) & Nash Draw; Delaware/BS (Avalon Sand) **Pool Code:** 98220 / 47545

**SUBMIT ACCURATE AND COMPLETE INFORMATION REQUIRED TO PROCESS THE TYPE OF APPLICATION INDICATED BELOW**

- 1) **TYPE OF APPLICATION:** Check those which apply for [A]  
 A. Location – Spacing Unit – Simultaneous Dedication  
 NSL       NSP (PROJECT AREA)       NSP (PRORATION UNIT)       SD
- B. Check one only for [ I ] or [ II ]  
 [ I ] Commingling – Storage – Measurement  
 DHC    CTB    PLC    PC    OLS    OLM  
 [ II ] Injection – Disposal – Pressure Increase – Enhanced Oil Recovery  
 WFX    PMX    SWD    IPI    EOR    PPR

- 2) **NOTIFICATION REQUIRED TO:** Check those which apply.  
 A.  Offset operators or lease holders  
 B.  Royalty, overriding royalty owners, revenue owners  
 C.  Application requires published notice  
 D.  Notification and/or concurrent approval by SLO  
 E.  Notification and/or concurrent approval by BLM  
 F.  Surface owner  
 G.  For all of the above, proof of notification or publication is attached, and/or,  
 H.  No notice required

<u>FOR OCD ONLY</u>	
<input type="checkbox"/>	Notice Complete
<input type="checkbox"/>	Application Content Complete

3) **CERTIFICATION:** I hereby certify that the information submitted with this application for administrative approval is **accurate** and **complete** to the best of my knowledge. I also understand that **no action** will be taken on this application until the required information and notifications are submitted to the Division.

**Note: Statement must be completed by an individual with managerial and/or supervisory capacity.**

Russell Young

Print or Type Name

2/25/2026  
Date

832-302-5430  
Phone Number

*Russell Young*

Signature

russell.young@exxonmobil.com  
e-mail Address



February 25, 2026

**VIA ONLINE FILING**

Albert C.S. Chang, Division Director  
Oil Conservation Division  
New Mexico Department of Energy, Minerals and Natural Resources  
1220 South Saint Francis Drive  
Santa Fe, NM 87505

**Re: Application of XTO Energy, Inc. for administrative approval to surface commingle two (2) participating areas (PA) of oil and gas production comprised of Sections 1, and 11 through 14; Township 23 South, Range 29 East, NMPM; Sections 6, 7 and 18; Township 23 South, Range 30 East, NMPM; Eddy County, New Mexico.**

Dear Mr. Chang:

XTO Energy, Inc (OGRID No. 5380) (“XTO”), pursuant to 19.15.12.10 NMAC, seeks administrative approval to **surface commingle** (on lease) diversely owned oil and gas production at the Nash Draw Unit 39H Central Tank Battery (“Facility”) *insofar as all existing and future wells drilled in the following:*

- (a) The **479.09-acre** of Participating Area (PA) **NMNM 070992D / NMNM 105670174** comprised of Section 1: L2, L4, S/2 NW/4, SW/4 (ada W/2); Section 12: NW/4; Township 22 South, Range 29 East, in the **[98220] PURPLE SAGE; WOLFCAMP (GAS)** currently dedicated to the following well:

30-015-21781	NASH UNIT	003H
--------------	-----------	------

- (b) The **5,122.86-acre** of Participating Area (PA) **NMNM 070992C / NMNM 105451826** comprised of Section 1: Lot 1 – Lot 4, S/2 N/2, S/2 (ada All); Section 11: All; Section 12: All; Section 13: All; Section 14: All; Township 22 South, Range 29 East and Section 6: Lot 1-Lot 7, SE/4 NW/4, S/2 NE/4, E/2 SW/4, SE/4 (ada All), Section 7: Lot 1 – Lot 14; Township 22 South, Range 30 East, in the **[47545] NASH DRAW; DELAWARE/BS (AVAOLON SAND)** currently dedicated to the following well:

30-015-21800	NASH UNIT	005
30-015-33991	NASH UNIT	034H
30-015-30176	NASH UNIT	036H
30-015-36951	NASH UNIT	039H
30-015-37166	NASH UNIT	040H

XTO Permian Operating, LLC.  
Russell Young  
3617 North Big Spring Street  
Midland, TX 79707  
832-302-5430  
Russell.young@exxonmobil.com

30-015-37165	NASH UNIT	041H
30-015-42206	NASH UNIT	043H

(c) Pursuant to 19.15.12.10.C(4)(g), *from all future additions of pools, leases or leases and pools to the Nash Draw Unit 39H Central Tank Battery* with notice provided only to the owners of interests to be added.

Oil and gas production from these spacing units will be commingled and sold at the Facility, located in the NESW of Section 12, T23S, R29E. XTO plans to use the well test method for allocation of production and measurement purposes. Production will flow from the wellbore to either a test separator or bulk (common) production separator. The test separator will separate the gas, oil, and water. Gas production from the test separator will be metered with a calibrated orifice meter that is manufactured to AGA specifications. Oil production from the test separator will be metered using a Coriolis meter. Gas and oil production will then be allocated daily based on the most recent individual well tests of oil, gas and water.

**Exhibit 1** is a land plat showing XTO's current development plan, well pads, and the Facility in the subject area. The plat also identifies the wellbores and lease/spacing unit boundaries.

**Exhibit 2** is a completed Application for Surface Commingling (Diverse Ownership) Form C-107-B, that includes a statement from Steven D. Wolfe, Senior Facilities Engineer with XTO, explaining how XTO plans to utilize the well test method and the measurement devices to be utilized, along with a detailed schematic of the surface facilities (Attachment A to the statement).

Ownership is diverse between the above-described spacing units, each of which are either subject to a pooling agreement or a pooling order and are therefore considered "leases" as defined by 19.15.12.7(C) NMAC. **Exhibit 3** is a list of the interest owners (including any owners of royalty or overriding royalty interest) affected by this application, an example of the letters sent by certified mail advising the interest owners that any objections must be filed in writing with the Division within 20 days from the date the Division receives this application, and proof of mailing. A copy of this application has been provided to the Bureau of Land Management since federal lands are involved.

Thank you for your consideration of this application. For questions concerning this application, please contact Crystal Walker at [crystal.l.walker@exxonmobil.com](mailto:crystal.l.walker@exxonmobil.com) or (505) 793-2398.

Sincerely,

*Russell Young*

Russell Young  
New Mexico Commingle Manager  
Permian Business Unit

XTO Permian Operating, LLC.  
Russell Young  
3617 North Big Spring Street  
Midland, TX 79707  
832-302-5430  
[Russell.young@exxonmobil.com](mailto:Russell.young@exxonmobil.com)

# Nash Draw Unit 39H Facility Lease Map

EDDY COUNTY, NM

### Legend

- Gas FMP/Sales Meter
- Oil FMP/Sales Meter
- CTB SITE
- PAD
- STATE SURFACE & MINERAL LEASE
- FEDERAL SURFACE & MINERAL LEASE
- PRIVATE SURFACE LEASE
- NMNM070992C
- NMNM070992D
- NASH UNIT

### Wells

- PAD A  
3001521800 NASH UNIT 5
- PAD B  
3001530176 NASH UNIT 036H
- PAD C  
3001533991 NASH UNIT 034H  
3001542206 NASH UNIT 043H
- NASH DRAW UNIT 39H FACILITY  
3001536951 NASH UNIT 039H  
3001537165 NASH UNIT 041H  
3001537166 NASH UNIT 040H

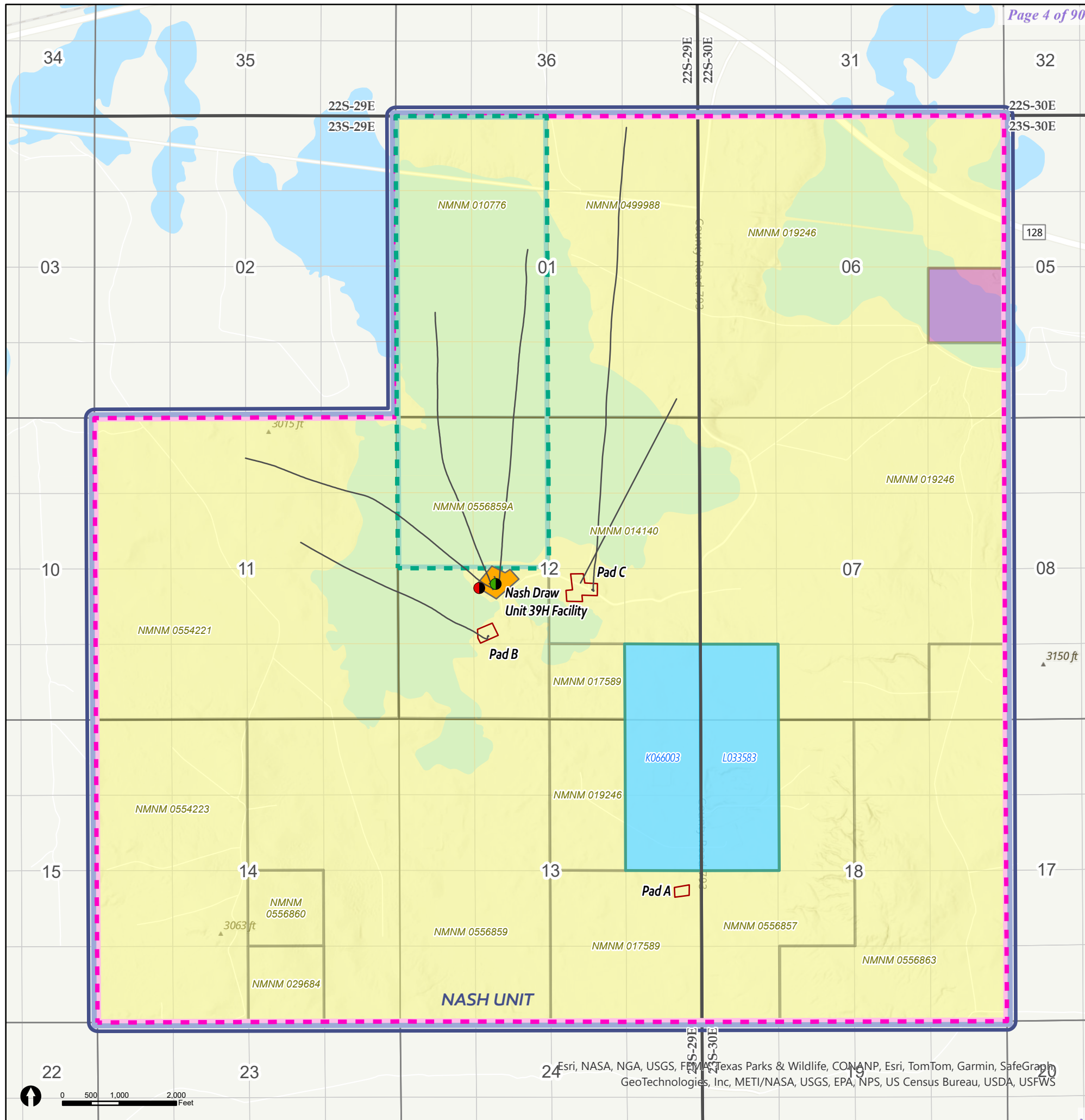

Santa Fe Main Office  
 Phone: (505) 476-3441  
 General Information  
 Phone: (505) 629-6116

State of New Mexico  
 Energy, Minerals and Natural Resources Department

Form C-107-B  
 Revised August 1, 2011

**OIL CONSERVATION DIVISION**  
 1220 S. St Francis Drive  
 Santa Fe, New Mexico 87505

Submit the original application to the Santa Fe office with one copy to the appropriate District Office.

Online Phone Directory Visit:  
<https://www.emnrd.nm.gov/ocd/contact-us/>

**APPLICATION FOR SURFACE COMMINGLING (DIVERSE OWNERSHIP)**

OPERATOR NAME: XTO Energy, Inc  
 OPERATOR ADDRESS: 3617 North Big Spring Street, Midland, TX 79705  
 APPLICATION TYPE:

Pool Commingling  Lease Commingling  Pool and Lease Commingling  Off-Lease Storage and Measurement (Only if not Surface Commingled)

LEASE TYPE:  Fee  State  Federal

Is this an Amendment to existing Order?  Yes  No If "Yes", please include the appropriate Order No. \_\_\_\_\_  
 Have the Bureau of Land Management (BLM) and State Land office (SLO) been notified in writing of the proposed commingling  
 Yes  No

**(A) POOL COMMINGLING**  
 Please attach sheets with the following information

(1) Pool Names and Codes	Gravities / BTU of Non-Commingled Production	Calculated Gravities / BTU of Commingled Production		Calculated Value of Commingled Production	Volumes
Purple Sage; Wolfcamp (Gas) - 98220	47.4 / 1223	47.15 / 1241		Gas \$7.72 Oil \$62.07	
Nash Draw; Delaware/BS (Avalon Sand) - 47545	46.9 / 1258				

(2) Are any wells producing at top allowables?  Yes  No  
 (3) Has all interest owners been notified by certified mail of the proposed commingling?  Yes  No.  
 (4) Measurement type:  Metering  Other (Specify) Well Testing  
 (5) Will commingling decrease the value of production?  Yes  No If "yes", describe why commingling should be approved

**(B) LEASE COMMINGLING**  
 Please attach sheets with the following information

(1) Pool Name and Code.  
 (2) Is all production from same source of supply?  Yes  No  
 (3) Has all interest owners been notified by certified mail of the proposed commingling?  Yes  No  
 (4) Measurement type:  Metering  Other (Specify)

**(C) POOL and LEASE COMMINGLING**  
 Please attach sheets with the following information

(1) Complete Sections A and E.

**(D) OFF-LEASE STORAGE and MEASUREMENT**  
 Please attached sheets with the following information

(1) Is all production from same source of supply?  Yes  No  
 (2) Include proof of notice to all interest owners.

**(E) ADDITIONAL INFORMATION (for all application types)**  
 Please attach sheets with the following information

(1) A schematic diagram of facility, including legal location.  
 (2) A plat with lease boundaries showing all well and facility locations. Include lease numbers if Federal or State lands are involved.  
 (3) Lease Names, Lease and Well Numbers, and API Numbers.

I hereby certify that the information above is true and complete to the best of my knowledge and belief.

SIGNATURE: Russell Young TITLE: Russell Young DATE: 2/25/2026

TYPE OR PRINT NAME Russell Young TELEPHONE NO.: 832-302-5430

E-MAIL ADDRESS: russell.young@exxonmobil.com

**APPLICATION FOR COMMINGLING AND ALLOCATION APPROVAL**  
**NASH DRAW UNIT 39H FACILITY**

XTO Energy, Inc. requests approval, pursuant to 43 CFR § 3173.14(b)(5), H.R. 1 (OBBBA) and IM 2025-034, and 43CFR 3173.15 to commingle surface production at the NASH DRAW UNIT 39H FACILITY. XTO requests for a CAA to combine production from two Participating Areas (PA) with different proportional interest before production is measured at an approved Facility Measurement Point (FMP). FMPs are located on Federal Lands within at least one of the approved leases which grants BLM access of 43 CFR 3173.23(e) and are “on lease” (See attached Lease Map). The federal leases have the same royalty rate percentage. All wells are expected to produce in paying quantities (see table below). XTO is the designated operator; therefore, no operator agreement is required. Since the application is being made under 43 CFR § 3173.14(b)(5), a gas analysis is required (see tables below). No new surface disturbance is needed.

**List of Leases and CAs to be included:**

Lease Type	Lease Number	Formation	Land Description	Type of Product	Proportional Interest	Royalty Percentage	Dedicated Acreage	BTU	Oil Gravity
Participating Area (PA)	NMNM070992D / NMNM105670174	Wolfcamp	T22S, R29E, Sec. 1: L3, L4, S/2 NW/4, SW/4 (ada W/2); Sec. 12: NW/4	Oil & Gas	Federal - 100%	Federal - 12.5%	479.09	1223	47.4
Participating Area (PA)	NMNM070992C / NMNM105451826	Delaware	T22S, R29E, SEC. 1: L1-L4, S/2 N/2, S/2 (ada All); Sec. 11: All; Sec. 12: All; Sec. 13: All; Sec. 14: All; T22S, R30E, Sec. 6: L1-L7, SE/4 NW/4, S/2 NE/4, E/2 SW/4, SE/4 (ada All); Sec. 7: L1-L4, E/2 W/2, E/2 (ada All), Sec. 18: L1-L4, E/2 W/2, E/2 (ada All)	Oil & Gas	Federal - 95.2692% State - 4.7308%	Federal - 12.5%	5,122.86	1258	46.9

**Facility Process Flow and Measurement**

The production from each well will flow from its respective surface hole location through a flowline to an inlet header at the facility. The inlet header directs the well production into either a test separator or bulk (common) production separator. If a well is not directed to the test separator, the flow is directed into the bulk production separator.

The test separator is a horizontal vessel where the gas, oil, and water are separated and measured. The gas flow is measured using an orifice meter following API Standard MPMS14.3.2 and the flow is calculated using an electronic flow meter (EFM). The oil flow is measured using a meter following the API Standard MPMS 5.6. The water flow is measured using a meter. Well test by separating and metering the oil production from the well for either (a) a minimum of twenty-four (24) consecutive hours; or (b) a combination of nonconsecutive periods that meet the following conditions: (i) each period shall be a minimum of six (6) hours; and (ii) the total duration of the nonconsecutive periods shall be a minimum of eighteen (18) hours. The Well Test Method used follows the API Standard MPMS 20.1 and meets state and federal regulations.

At the facility production is separated into oil, gas and water. The oil then flows into a heater treater. From the heater treater the oil is routed to a Vapor Recovery Tower (VRT) and then transferred into the oil pipeline using a LACT unit used as an FMP/sales meter.

The facility design has common ancillary equipment that includes—vapor recovery units, flares, and a water system. The flash gas is metered and then will enter the primary gas line after all FMPs / sales meter.

**Reservoir Forecasted Declines**

These wells may produce high volumes for a short three-month period and are then expected to decline for the remaining life of each well. After the initial period of hyperbolic decline, production stabilizes at a more predictable exponential decline rate.

**Production and Allocation**

Based on the decline rates, the wells will be tested at differing frequencies for optimum accuracy. Well tests will be for either (a) a minimum of twenty-four (24) consecutive hours; or (b) a combination of nonconsecutive periods

that meet the following conditions: (i) each period shall be a minimum of six (6) hours; and (ii) the total duration of the nonconsecutive periods shall be a minimum of eighteen (18) hours. Based on the production decline, the following three periods will be used to determine well test frequency:

- Range 1 – Initial Production Period – from the first production until the earlier of either the peak production rate or thirty (30) days after the first production; minimum 10 well tests/per month
- Range 2 – Plateau Period – the end of the initial production period to the peak decline rate; minimum 3 well tests/per month
- Range 3 – Decline Period – the end of plateau period until well is plugged and abandoned; minimum 3 well tests/ per month when the decline rate is >22% per month, 2 well tests/per month when the decline rate is between 22%-10% per month, and 1 well test/per month when the decline rate is <10% per month

**Methodology**

Gas and oil production will then be allocated daily based on the most recent individual well tests of oil, gas and water. The time increment for reported sales through the sales meters is monthly. Allocation methods are explained in the white and blue rows above the table and the data within the table can be identified as such: all calculated data is in green text and statement/meter data is in blue text.

Pursuant to Statewide rule 19.15.12.10(C)(4)(g) XTO requests the option to include all future wells drilled in these pools and leases to this commingle order.

**Commingle approval will allow XTO to efficiently and effectively market production from the subject acreage.**

**List of Wells to be included in CAA with Production Volumes**

API	Well Name	Well Number	Pool	Pool CODE	BPD	MCFD	Projected or Actual
30-015-21781	NASH UNIT	#003H	Purple Sage; Wolfcamp (Gas)	98220	48.29	1127.18	Actual
30-015-21800	NASH UNIT	#005	Nash Draw; Delaware/BS (Avaolon Sand)	47545	10.11	53.39	Actual
30-015-33991	NASH UNIT	#034H	Nash Draw; Delaware/BS (Avaolon Sand)	47545	36.96	289.31	Actual
30-015-30176	NASH UNIT	#036H	Nash Draw; Delaware/BS (Avaolon Sand)	47545	52.46	302.39	Actual
30-015-36951	NASH UNIT	#039H	Nash Draw; Delaware/BS (Avaolon Sand)	47545	49.78	319.48	Actual
30-015-37166	NASH UNIT	#040H	Nash Draw; Delaware/BS (Avaolon Sand)	47545	49.67	315.33	Actual
30-015-37165	NASH UNIT	#041H	Nash Draw; Delaware/BS (Avaolon Sand)	47545	48.44	358.44	Actual
30-015-42206	NASH UNIT	#043H	Nash Draw; Delaware/BS (Avaolon Sand)	47545	70.74	431.47	Actual

**Exhibits:**

1. Lease Map
2. Allocation Methodology
3. Serial Register Pages

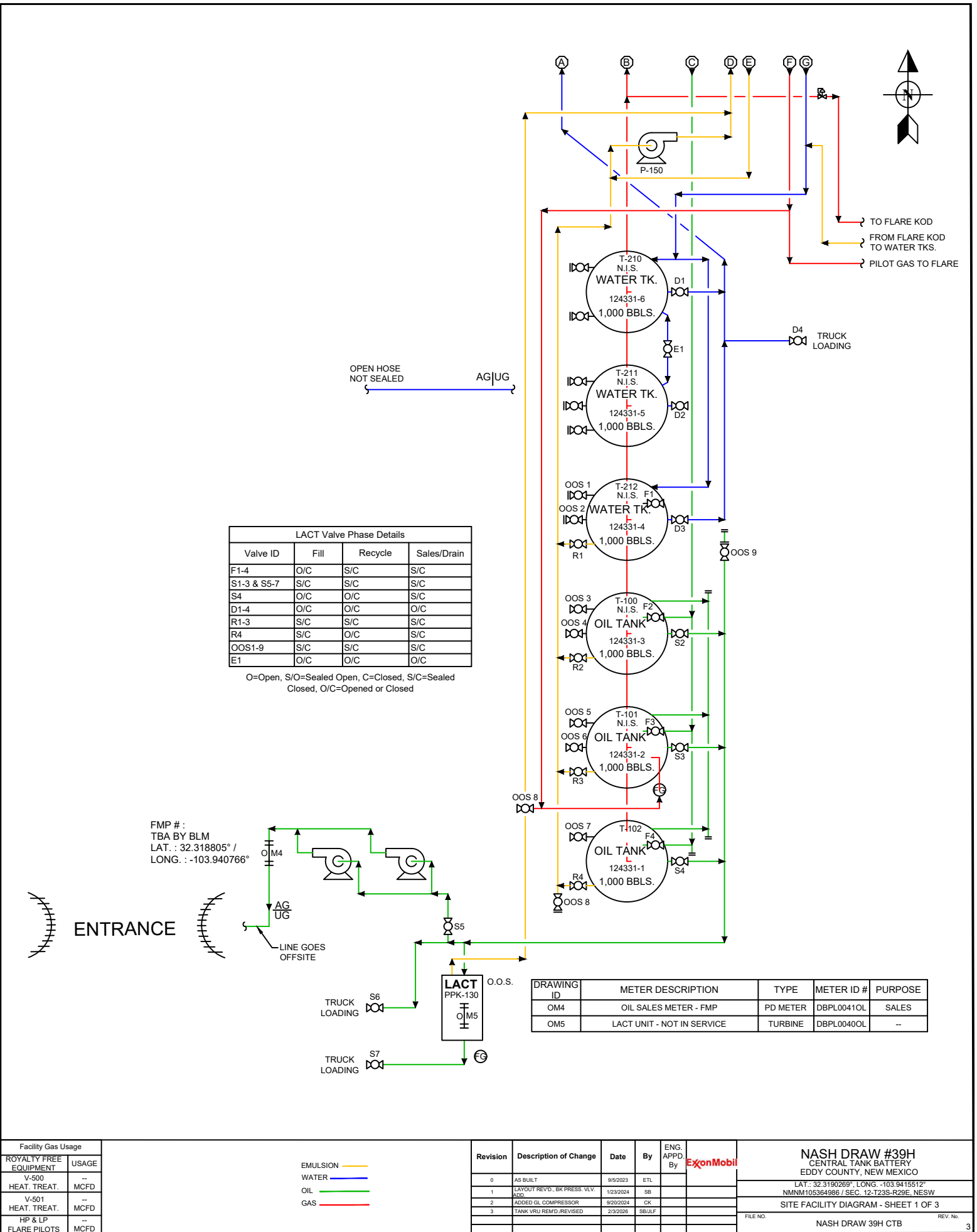

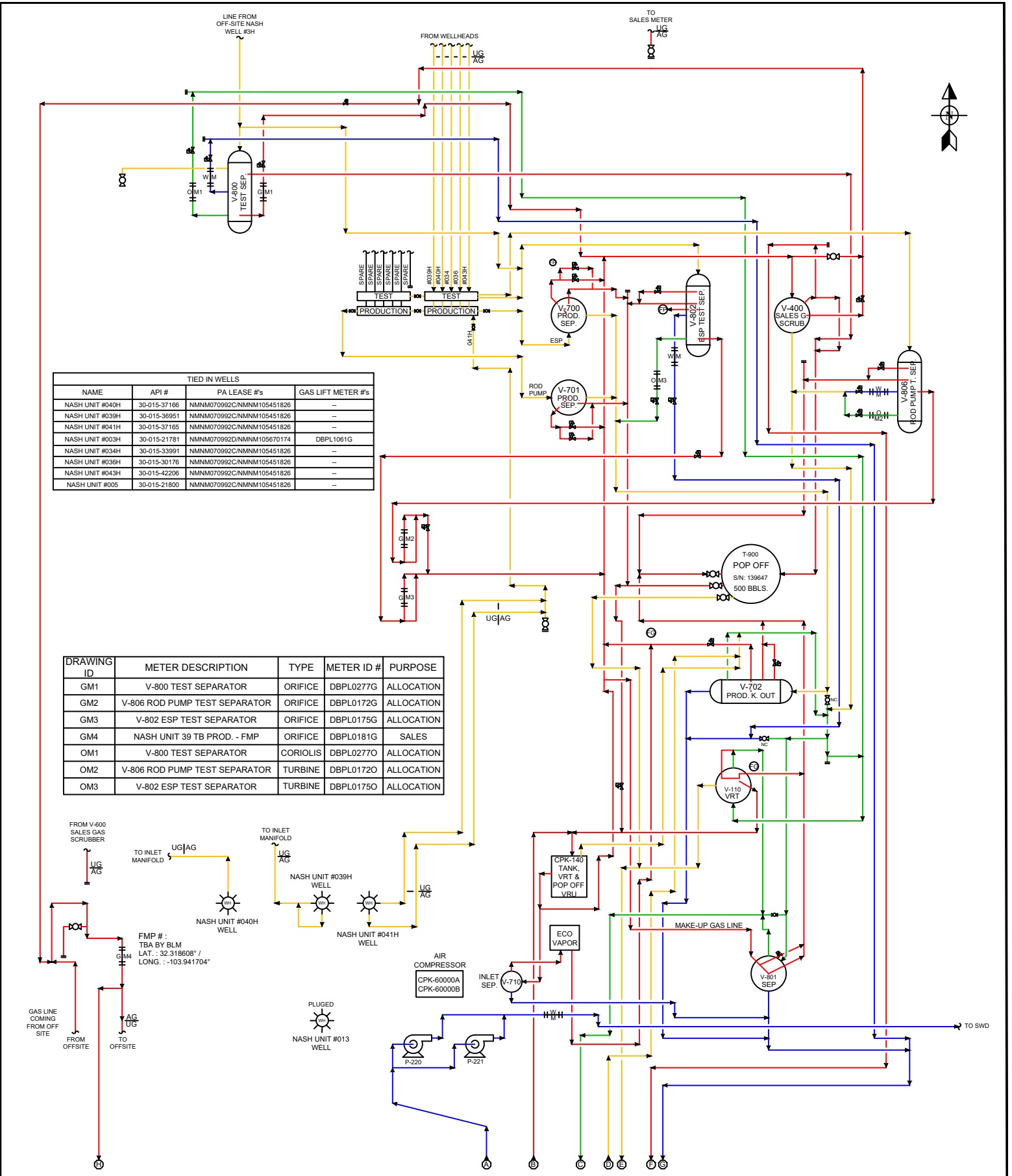

TIED IN WELLS			
NAME	API #	PA LEASE #'s	GAS LIFT METER #'s
NASH UNIT #040H	30-015-37166	NMNM070992C/NMNM105451826	--
NASH UNIT #039H	30-015-36951	NMNM070992C/NMNM105451826	--
NASH UNIT #041H	30-015-37165	NMNM070992C/NMNM105451826	--
NASH UNIT #003H	30-015-21781	NMNM070992D/NMNM105670174	DBPL1061G
NASH UNIT #034H	30-015-33991	NMNM070992C/NMNM105451826	--
NASH UNIT #036H	30-015-30176	NMNM070992C/NMNM105451826	--
NASH UNIT #043H	30-015-42206	NMNM070992C/NMNM105451826	--
NASH UNIT #005	30-015-21800	NMNM070992C/NMNM105451826	--

DRAWING ID	METER DESCRIPTION	TYPE	METER ID #	PURPOSE
GM1	V-800 TEST SEPARATOR	ORIFICE	DBPL0277G	ALLOCATION
GM2	V-806 ROD PUMP TEST SEPARATOR	ORIFICE	DBPL0172G	ALLOCATION
GM3	V-802 ESP TEST SEPARATOR	ORIFICE	DBPL0175G	ALLOCATION
GM4	NASH UNIT 39 TB PROD. - FMP	ORIFICE	DBPL0181G	SALES
OM1	V-800 TEST SEPARATOR	CORIOLIS	DBPL0277O	ALLOCATION
OM2	V-806 ROD PUMP TEST SEPARATOR	TURBINE	DBPL0172O	ALLOCATION
OM3	V-802 ESP TEST SEPARATOR	TURBINE	DBPL0175O	ALLOCATION

<table border="1"> <thead> <tr> <th>Facility Gas Usage</th> <th>USAGE</th> </tr> </thead> <tbody> <tr> <td>ROYALTY FREE EQUIPMENT</td> <td>--</td> </tr> <tr> <td>V-500 HEAT. TREAT.</td> <td>MCFD</td> </tr> <tr> <td>V-501 HEAT. TREAT.</td> <td>MCFD</td> </tr> <tr> <td>HP &amp; LP FLARE PILOTS</td> <td>MCFD</td> </tr> </tbody> </table>		Facility Gas Usage	USAGE	ROYALTY FREE EQUIPMENT	--	V-500 HEAT. TREAT.	MCFD	V-501 HEAT. TREAT.	MCFD	HP & LP FLARE PILOTS	MCFD	<p>EMULSION —</p> <p>WATER —</p> <p>OIL —</p> <p>GAS —</p>	<table border="1"> <thead> <tr> <th>Revision</th> <th>Description of Change</th> <th>Date</th> <th>By</th> <th>ENG. APPD. By</th> </tr> </thead> <tbody> <tr> <td>0</td> <td>AS BUILT</td> <td>9/5/2023</td> <td>ETL</td> <td></td> </tr> <tr> <td>1</td> <td>LAYOUT REV'D &amp; BK PRESS. VLV. ADD.</td> <td>1/23/2024</td> <td>SB</td> <td></td> </tr> <tr> <td>2</td> <td>ADDED GL COMPRESSOR</td> <td>8/20/2024</td> <td>CK</td> <td></td> </tr> <tr> <td>3</td> <td>TANK VRTU REMD./REVISED</td> <td>2/3/2026</td> <td>SB/JLF</td> <td></td> </tr> </tbody> </table>	Revision	Description of Change	Date	By	ENG. APPD. By	0	AS BUILT	9/5/2023	ETL		1	LAYOUT REV'D & BK PRESS. VLV. ADD.	1/23/2024	SB		2	ADDED GL COMPRESSOR	8/20/2024	CK		3	TANK VRTU REMD./REVISED	2/3/2026	SB/JLF		<p><b>NASH DRAW #39H</b> CENTRAL TANK BATTERY EDDY COUNTY, NEW MEXICO</p> <p>LAT.: 32.3190269°, LONG. -103.9415512° NMNM105364986 / SEC. 12-T23S-R29E, NESW</p> <p>SITE FACILITY DIAGRAM - SHEET 2 OF 3</p> <p>FILE NO. _____ REV. No. _____</p> <p>NASH DRAW 39H CTB</p>
Facility Gas Usage	USAGE																																						
ROYALTY FREE EQUIPMENT	--																																						
V-500 HEAT. TREAT.	MCFD																																						
V-501 HEAT. TREAT.	MCFD																																						
HP & LP FLARE PILOTS	MCFD																																						
Revision	Description of Change	Date	By	ENG. APPD. By																																			
0	AS BUILT	9/5/2023	ETL																																				
1	LAYOUT REV'D & BK PRESS. VLV. ADD.	1/23/2024	SB																																				
2	ADDED GL COMPRESSOR	8/20/2024	CK																																				
3	TANK VRTU REMD./REVISED	2/3/2026	SB/JLF																																				

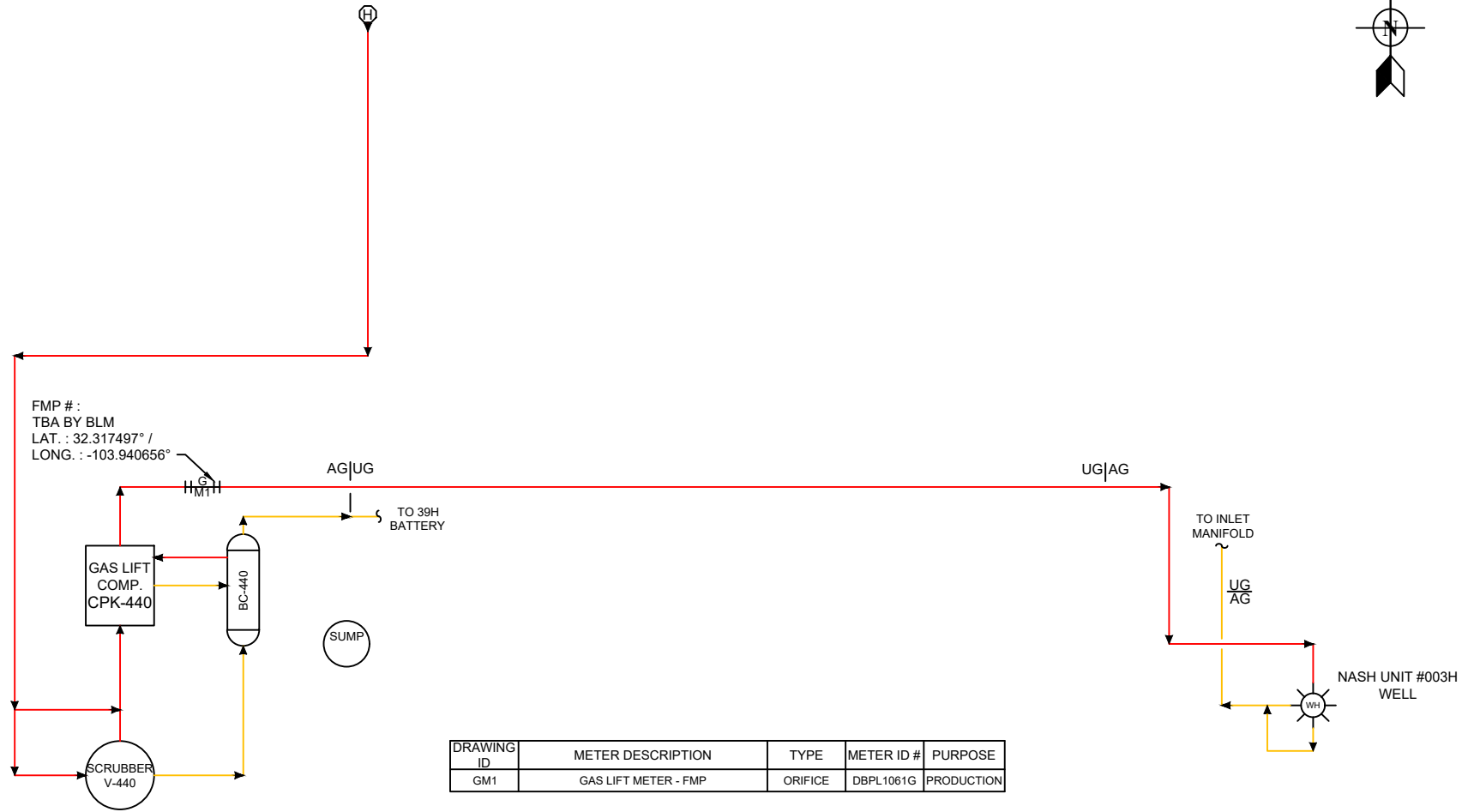

FMP # :  
TBA BY BLM  
LAT. : 32.317497° /  
LONG. : -103.940656°

DRAWING ID	METER DESCRIPTION	TYPE	METER ID #	PURPOSE
GM1	GAS LIFT METER - FMP	ORIFICE	DBPL1061G	PRODUCTION

Facility Gas Usage	
ROYALTY FREE EQUIPMENT	USAGE
V-500	--
HEAT. TREAT.	MCFD
V-501	--
HEAT. TREAT.	MCFD
HP & LP	--
FLARE PILOTS	MCFD

EMULSION ———  
WATER ———  
OIL ———  
GAS ———

Revision	Description of Change	Date	By	ENG. APPD. By
0	AS BUILT	9/5/2023	ETL	
1	LAYOUT REVISED AND BACK PRESSURE VALVE ADDED	1/23/2024	SB	
2	ADDED GL COMPRESSOR	9/20/2024	CK	
3	TANK VRU REM'D /REVISED	2/9/2026	SB/JLF	

**NASH DRAW #39H**  
CENTRAL TANK BATTERY  
EDDY COUNTY, NEW MEXICO

API #30-015-31690 / LAT.: 32.317463, LONG.: -103.94054)

SITE FACILITY DIAGRAM - SHEET 3 OF 3

FILE NO. REV. No.

NASH DRAW 39H CTB 3



February 25, 2026

**CERTIFIED MAIL**  
**RETURN RECEIPT REQUESTED**

TO: ALL AFFECTED PARTIES

**Re: Application of XTO Energy, Inc. for administrative approval to surface commingle two (2) participating areas (PA) of oil and gas production comprised of Sections 1, and 11 through 14; Township 23 South, Range 29 East, NMPM; Sections 6, 7 and 18; Township 23 South, Range 30 East, NMPM; Eddy County, New Mexico.**

To Whom It May Concern:

Enclosed is a copy of the above-referenced application, which was filed with the New Mexico Oil Conservation Division on this date. Any objection to this application must be filed in writing within twenty (20) days from the date this application is received by the Division's Santa Fe office located at 1220 South St. Francis Drive, Santa Fe, New Mexico, 87505. If no objection is received within this twenty-day period, this application may be approved administratively by the Division.

If you have any questions about this application, please contact the following:

Russell Young  
XTO Permian Operating, LLC  
(832) 302-5430  
[russell.young@exxonmobil.com](mailto:russell.young@exxonmobil.com)

Sincerely,

*Russell Young*

Russell Young  
New Mexico Commingle Manager  
Permian Business Unit

XTO Permian Operating, LLC.  
Russell Young  
3617 North Big Spring Street  
Midland, TX 79705  
832-302-5430  
[Russell.young@exxonmobil.com](mailto:Russell.young@exxonmobil.com)

## NASH DRAW UNIT 39H - POSTAL DELIVERY LIST

RECEIPT #	NAME	ADDRESS	ADDRESS 2	STATE	ZIP	DATE SENT
94148149023689579335 24	WALKERLAND LLC	10315 RD 4	SIDNEY	NE	69162-0000	2.26.26
94148149023689579335 31	MILTON R FRY	11014 HIDDEN BEND DR	HOUSTON	TX	77064-0000	2.26.26
94148149023689579335 48	ELIZABETH T OVERLY	11410 SHADOW WAY STREET	HOUSTON	TX	77024-5215	2.26.26
94148149023689579335 55	MATTHEW DAVID OAKES	116 N JOHNSON AVE	SAN MARCOS	TX	78666-4127	2.26.26
94148149023689579335 62	KANDI KAE WILKINSON	1280 RD 109	SIDNEY	NE	69162-0000	2.26.26
94148149023689579335 79	ROBIN L MORGAN	135 WEST COTTONWOOD RD	ARTESIA	NM	88210-0000	2.26.26
94148149023689579335 86	DAVID TRENT DALTON	1385 HOMESTEAD	KEMPNER	TX	76539-5056	2.26.26
94148149023689579335 93	BRIAN W HIETT	1400 ELM STREET	SIDNEY	NE	69162	2.26.26
94148149023689579336 09	SITIO PERMIAN LP	1401 LAWRENCE STREET STE 1750	DENVER	CO	80202	2.26.26
94148149023689579336 16	ELIZABETH ANN CLINE	15400 WHISTLING STRAITS DR	AUSTIN	TX	78717-3838	2.26.26
94148149023689579336 23	BARBARA SHELBY BAETZ	1626 MILFORD ST	HOUSTON	TX	77006	2.26.26
94148149023689579336 30	LAURA AND JOHN ARNOLD FOUNDATION	1717 WEST LOOP SOUTH SUITE 180	HOUSTON	TX	77027	2.26.26
94148149023689579336 47	SHOGOIL AND GAS CO II LLC	1751 HOVER ST STE B4 206	LONGMONT	CO	80501-7181	2.26.26
94148149023689579336 54	THOMAS J DEPKE DTD 11/19/2004	2027 COUNTRY FIELD DR	CHESTERFIELD	MO	63017	2.26.26
94148149023689579336 61	RIDGE RUNNER RESOURCES II LLC	20405 STATE HIGHWAY 249 SUITE	HOUSTON	TX	77070	2.26.26
94148149023689579336 78	WING RESOURCES IV LLC	2100 MCKINNEY AVE STE 1540	DALLAS	TX	75201	2.26.26
94148149023689579336 85	WING RESOURCES VII LLC	2100 MCKINNEY AVE SUITE 1540	DALLAS	TX	75201	2.26.26
94148149023689579336 92	PERMIAN BASIN INVESTMENT CORP	2108 QUAIL HOLLOW RUN	CARLSBAD	NM	88220-0000	2.26.26
94148149023689579337 08	MILLIS JEFFREY OAKES	21302 CASTLEMONT LN	SPRING	TX	77388-0000	2.26.26
94148149023689579337 15	BERTRAND O BAETZ III	217 BOBWHITE DR	KERRVILLE	TX	78028	2.26.26
94148149023689579337 22	ANNAMARIE FALVO	22 BRISTOL GREEN	SAN ANTONIO	TX	78209	2.26.26
94148149023689579337 39	CONCHO RESOURCES INC	22295 NETWORK PL	CHICAGO	IL	60673-1222	2.26.26
94148149023689579337 46	XTO HOLDINGS LLC-RU5737	22777 SPRINGWOODS VILLAGE PKWA	SPRING	TX	77389	2.26.26
94148149023689579337 53	XTO ROYALTY HOLDINGS LP RU4093	22777 SPRINGWOODS VILLAGE PKWY	SPRING	TX	77389	2.26.26
94148149023689579337 60	CLARY NEWTON AULER	2306 WOODLAWN BLVD	AUSTIN	TX	78703	2.26.26
94148149023689579337 77	MARGARET SHELBY NEWTON	2414 DORMARION LN	AUSTIN	TX	78703	2.26.26
94148149023689579337 84	WAMBAUGH EXPLORATION LLC	29 KENNEBEC DR	DURANGO	CO	81301-9490	2.26.26
94148149023689579337 91	OLIN BRENT DALTON	335 GRANITE ROW	MEADOWLAKES	TX	78654-6411	2.26.26
94148149023689579338 07	THOMAS D GUNDERSEN	3405 LUNS福德 CT	RENO	NV	89511-7628	2.26.26
94148149023689579338 14	JACK J. GRYNBERG	3600 SOUTH YOSEMITE ST	DENVER	CO	80237-0000	2.26.26
94148149023689579338 21	MONTICELLO MINERALS LLC	4128 BRYN MAWR DR	DALLAS	TX	75225-6736	2.26.26
94148149023689579338 38	SMP TITAN FLEX LP	4143 MAPLE AVE SUITE 500	DALLAS	TX	75219	2.26.26
94148149023689579338 45	MSH FAM REAL EST PRNTNSP II LLC	4143 MAPLE AVE SUITE 500	DALLAS	TX	75219	2.26.26
94148149023689579338 52	SMP SIDECAR TITAN	4143 MAPLE AVENUE STE 500	DALLAS	TX	75219	2.26.26
94148149023689579338 69	SMP TITAN MINERAL	4143 MAPLE AVENUE STE 500	DALLAS	TX	75219	2.26.26
94148149023689579338 76	PREVAIL ENERGY LLC	4254 E 8TH PL	DENVER	CO	80220	2.26.26
94148149023689579338 83	FRANKLIN MOUNTAIN ROYALTY	44 COOK STREET SUITE 1000	DENVER	CO	80206-0000	2.26.26
94148149023689579338 90	GRYNBERG PETROLEUM COMPANY LLC	4582 S ULSTER STREET SUITE 720	DENVER	CO	80237	2.26.26
94148149023689579339 06	STEPHEN WILLIAM OAKES	4700 SPANISH MOSS	MCKINNEY	TX	75070-0000	2.26.26
94148149023689579339 13	GARRY L BROWN	5328 CR 73	FLEMING	CO	80728-0000	2.26.26
94148149023689579339 20	MITCHELL EXPLORATION INC	6902 HOMESTEAD BLVD	MIDLAND	TX	79707	2.26.26
94148149023689579339 37	MICHELLE R SANDOVAL	6965 CORTE LANGOSTA	CARLSBAD	CA	92009	2.26.26
94148149023689579339 44	TD MINERALS LLC	8111 WESTCHESTER STE 900	DALLAS	TX	75225-0000	2.26.26
94148149023689579339 51	CHRISTIAN RELIEF SERVICES	8301 RICHMOND HWY	ALEXANDRIA	VA	22309-0000	2.26.26
94148149023689579339 68	S AND E ROYALTY LLC	8470 WEST 4TH AVE	LAKEWOOD	CO	80226-0000	2.26.26
94148149023689579339 75	HUTCHINGS OIL CO	8500 MENAUL BLVD NE STE B580	ALBUQUERQUE	NM	87112-1273	2.26.26
94148149023689579339 82	LORI ANN GUNDERSEN LIVING TRUST	900 GREENSBURG CIR	RENO	NV	89509	2.26.26
94148149023689579339 99	BUREAU OF LAND MANAGEMENT	301 DINOSAUR TRAIL	SANTA FE	NM	87508	2.26.26
94148149023689579340 02	NEW MEXICO STATE LAND OFFICE	310 OLD SANTA FE TRAIL	SANTA FE	NM	87504	2.26.26
94148149023689579340 19	MEC PETROLEUM CORPORATION	PO BOX 11265	MIDLAND	TX	79702-8265	2.26.26
94148149023689579340 26	NEWKUMET INVESTMENTS LLC	PO BOX 11330	MIDLAND	TX	79702	2.26.26
94148149023689579340 33	FRANCES ANNE HANNIFIN	PO BOX 13128	LAS CRUCES	NM	88013	2.26.26
94148149023689579340 40	MW OIL INVESTMENT COMPANY INC	PO BOX 13128	LAS CRUCES	NM	88013	2.26.26
94148149023689579340 57	MOTOWI LLC	PO BOX 13128	LAS CRUCES	NM	88013	2.26.26
94148149023689579340 64	FRANNIFIN MINERALS LLC	PO BOX 13128	LAS CRUCES	NM	88013	2.26.26
94148149023689579340 71	WORRALL INVESTMENT CORP	PO BOX 1834	ROSWELL	NM	88202-1834	2.26.26
94148149023689579340 88	ALAN R HANNIFIN	PO BOX 20129	SARASOTA	FL	34276-3129	2.26.26
94148149023689579340 95	FFF INC	PO BOX 20129	SARASOTA	FL	34276	2.26.26
94148149023689579341 01	MARK B MURPHY IRREV TR	PO BOX 2484	ROSWELL	NM	88202-2484	2.26.26
94148149023689579341 18	SUSAN S MURPHY MARITAL TR	PO BOX 2484	ROSWELL	NM	88202-2484	2.26.26
94148149023689579341 25	MAP98B NET	PO BOX 269100	OKLAHOMA CITY	OK	73126-9100	2.26.26
94148149023689579341 32	MAP 98A OK	PO BOX 269100	OKLAHOMA CITY	OK	73126-9100	2.26.26
94148149023689579341 49	RUTTER & WILBANKS	PO BOX 3186	MIDLAND	TX	79702-0000	2.26.26
94148149023689579341 56	BETH E FIEGENSCHUH	PO BOX 386	SIDNEY	NE	69162	2.26.26
94148149023689579341 63	INNOVENTIONS INC	PO BOX 40	CEDAR CREST	NM	87008-0000	2.26.26
94148149023689579341 70	FRANKLIN J BRADSHAW FAM TR	PO BOX 40909	AUSTIN	TX	78704-0000	2.26.26
94148149023689579341 87	LAWRENCE J BRADSHAW SPECIAL	PO BOX 40909	AUSTIN	TX	78704-0000	2.26.26
94148149023689579341 94	BERNICE J BRADSHAW CHARITABLE	PO BOX 40909	AUSTIN	TX	78704-0000	2.26.26
94148149023689579342 00	LAVINIA SCHREUDER TR	PO BOX 41779	AUSTIN	TX	78704-0000	2.26.26
94148149023689579342 17	MCMULLEN MINERALS II LP	PO BOX 470857	FORT WORTH	TX	76147	2.26.26
94148149023689579342 24	SOUTHWEST ROYALTIES INC	PO BOX 53570	MIDLAND	TX	79710-3570	2.26.26

94148149023689579342 31  
94148149023689579342 48  
94148149023689579342 55  
94148149023689579342 62  
94148149023689579342 79  
94148149023689579342 86  
94148149023689579342 93

CAYUGA ROYALTIES LLC	PO BOX 540711	HOUSTON	TX	77254	2.26.26
PEGASUS RESOURCES LLC	PO BOX 733980	DALLAS	TX	75373-3980	2.26.26
AG ANDRIKOPOULOS RESOURCES INC	PO BOX 788	CHEYENNE	WY	82003-0788	2.26.26
BENJAMIN JACOB OAKES	PO BOX 841151	PEARLAND	TX	77584-0000	2.26.26
BPL FISH POND LLC	PO BOX 92032	SOUTHLAKE	TX	76092	2.26.26
SYDHAN LP	PO BOX 92349	AUSTIN	TX	78709-0000	2.26.26
BR2 HOLDINGS LLC	PO BOX 980552	HOUSTON	TX	77098	2.26.26

# Affidavit of Publication

## Copy of Publication:

No. 87800

State of New Mexico

County of Eddy:

**Adrian Hedden**

being duly sworn, says that he is the Publisher

of the Carlsbad Current Argus, a weekly newspaper of general circulation, published in English at Carlsbad, said county and state, and that the hereto attached

### Legal Ad

was published in a regular and entire issue of the said Carlsbad Current Argus, a weekly newspaper duly qualified for that purpose within the meaning of Chapter 167 of the 1937 Session Laws of the state of New Mexico for 1 Consecutive weeks/day on the same

day as follows:

First Publication March 7, 2026

Second Publication \_\_\_\_\_

Third Publication \_\_\_\_\_

Fourth Publication \_\_\_\_\_

Fifth Publication \_\_\_\_\_

Sixth Publication \_\_\_\_\_

Seventh Publication \_\_\_\_\_

Eighth Publication \_\_\_\_\_

Subscribed and sworn before me this

7th day of March 2026

LATISHA ROMINE  
Notary Public, State of New Mexico  
Commission No. 1076338  
My Commission Expires  
05-12-2027

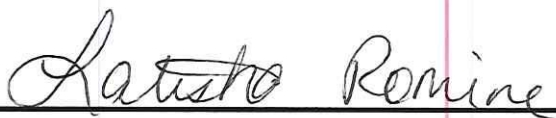

Latisha Romine

Notary Public, Eddy County, New Mexico

TO: ALL AFFECTED PARTIES, INCLUDING: WALKERLAND LLC MILTON R FRY ELIZABETH T OVERLY MATTHEW DAVID OAKES KANDI KAE WILKINSON ROBIN L MORGAN DAVID TRENT DALTON BRIAN W HIETT SITIO PERMIAN LP ELIZABETH ANN CLINE BARBARA SHELBY BAETZ LAURA AND JOHN ARNOLD FOUNDATION SHOGOIL AND GAS CO II LLC THOMAS J DEPKE DTD 11/19/2004 RIDGE RUNNER RESOURCES II LLC WING RESOURCES IV LLC WING RESOURCES VII LLC PERMIAN BASIN INVESTMENT CORP MILLIS JEFFREY OAKES BERTRAND O BAETZ III ANNAMARIE FALVO CONCHO RESOURCES INC XTO HOLDINGS LLC-RU5737 XTO ROYALTY HOLDINGS LP RU4093 CLARY NEWTON AULER MARGARET SHELBY NEWTON WAMBAUGH EXPLORATION LLC OLIN BRENT DALTON THOMAS D GUNDERSEN JACK J. GRYNBERG MONTICELLO MINERALS LLC SMP TITAN FLEX LP MSH FAM REAL EST PRNTSP II LLC SMP SIDECAR TITAN SMP TITAN MINERAL PREVAIL ENERGY LLC FRANKLIN MOUNTAIN ROYALTY GRYNBERG PETROLEUM COMPANY LLC STEPHEN WILLIAM OAKES GARRY L BROWN MITCHELL EXPLORATION INC MICHELLE R SANDOVAL TD MINERALS LLC CHRISTIAN RELIEF SERVICES S AND E ROYALTY LLC HUTCHINGS OIL CO LORI ANN GUNDERSEN LIVING TRUST BUREAU OF LAND MANAGEMENT NEW MEXICO STATE LAND OFFICE MEC PETROLEUM CORPORATION NEWKUMET INVESTMENTS LLC FRANCES ANNE HANNIFIN MW OIL INVESTMENT COMPANY INC MOTOWI LLC FRANNIFIN MINERALS LLC WORRALL INVESTMENT CORP ALAN R HANNIFIN FFF INC MARK B MURPHY IRREV TR SUSAN S MURPHY MARITAL TR MARK B MURPHY IRREV TR SUSAN S MURPHY MARITAL TR MAP98B NET MAP 98A OK RUTTER & WILBANKS BETH E FIEGENSCHUH INNOVENTIONS INC FRANKLIN J BRADSHAW FAM TR LAWRENCE J BRADSHAW SPECIAL BERNICE J BRADSHAW CHARITABLE FRANKLIN J BRADSHAW FAM TR LAWRENCE J BRADSHAW SPECIAL BERNICE J BRADSHAW CHARITABLE LAVINIA SCHREUDER TR MCMULLEN MINERALS II LP SOUTHWEST ROYALTIES INC CAYUGA ROYALTIES LLC PEGASUS RESOURCES LLC AG ANDRIKOPOULOS RESOURCES INC BENJAMIN JACOB OAKES BPL FISH POND LLC SYDHAN LP BR2 HOLDINGS LLC

separate the gas, oil, and water. Gas production from the test separator will be metered with a calibrated orifice meter that is manufactured to AGA specifications. Oil production from the test separator will be metered using a Coriolis meter. Gas and oil production will then be allocated daily based on the most recent individual well tests of oil, gas and water

Any objection to this application must be filed in writing within twenty (20) days from the date of publication with the New Mexico Oil Conservation Division, 1220 South St. Francis Drive, Santa Fe, New Mexico, 87505. If no objection is received within this twenty-day period, this application may be approved administratively by the Division. If you have any questions about this application, please contact Russell Young, XTO Energy, Inc., (832)-454-2857 or Russell.young@exxonmobil.com.

87800-Published in Carlsbad Current Argus March 7, 2026.

Application of XTO Energy, Inc. for administrative approval to surface commingle two (2) participating areas (PA) of oil and gas production comprised of Sections 1, and 11 through 14; Township 23 South, Range 29 East, NMPM; Sections 6, 7 and 18; Township 23 South, Range 30 East, NMPM; Eddy County, New Mexico.

XTO Energy, Inc (OGRID No. 5380) (XTO), pursuant to 19.15.12.10 NMAC, seeks administrative approval to surface commingle (on lease) diversely owned oil and gas production at the Nash Draw Unit 39H Central Tank Battery (Facility) insofar as all existing and future wells drilled in the following:

(a) The 479.09-acre of Participating Area (PA) NMNM 070992D / NMNM 105670174 comprised of Section 1: L2, L4, S/2 NW/4, SW/4 (ada) W/2; Section 12: NW/4; Township 22 South, Range 29 East, in the [98220] PURPLE SAGE; WOLFCAMP (GAS) currently dedicated to the following well:

30-015-21781 NASH UNIT 003H

(b) The 5,122.86-acre of Participating Area (PA) NMNM 070992C / NMNM 105451826 comprised of Section 1: Lot 1 Lot 4, S/2 N/2, S/2 (ada All); Section 11: All; Section 12: All; Section 13: All; Section 14: All; Township 22 South, Range 29 East and Section 6: Lot 1-Lot 7, SE/4 NW/4, S/2 NE/4, E/2 SW/4, SE/4 (ada All). Section 7: Lot 1 Lot 14; Township 22 South, Range 30 East, in the [47545] NASH DRAW; DELAWARE/BS (AVAOLON SAND) currently dedicated to the following well:

30-015-21800 NASH UNIT 005  
 30-015-33991 NASH UNIT 034H  
 30-015-30176 NASH UNIT 036H  
 30-015-36951 NASH UNIT 039H  
 30-015-37166 NASH UNIT 040H  
 30-015-37165 NASH UNIT 041H  
 30-015-42206 NASH UNIT 043H

(c) Pursuant to 19.15.12.10.C(4)(g), from all future additions of pools, leases or leases and pools to the Nash Draw Unit 39H Central Tank Battery with notice provided only to the owners of interests to be added.

Oil and gas production from these spacing units will be commingled and sold at the Facility, located in the NESW of Section 12, T23S, R29E. XTO plans to use the well test method for allocation of production and measurement purposes. Production will flow from the wellbore to either a test separator or bulk (common) production separator. The test separator will

Help



# Product Tracking & Reporting

Home

Search

Reports

Manual Entry

Rates/  
Commitments

PTR / EDW

Customer  
Information

June 01, 2026

## USPS Tracking Intranet

### Delivery Signature and Address



- 1. Do not share information from this site outside of USPS. It is intended for USPS employee use only.
- 2. Employees may see some items with only event MT in the tracking record. This is an indication that the tracking number was part of problem where the USPS Label Creation API created the same label number multiple times. This led to a confusing tracking experience, so tracking has been suppressed. Reference this ticket for more info: INC000010676253, INC000010539853.

Tracking Number: 9414 8149 0236 8957 9358 18

CONDICO PHILIPS COMPANY

This item was delivered on 03/05/2026 at 08:05:00

[< Return to Tracking Number View](#)

Signature	Delivery Section	
Address	LAVIER SALAS	
	Delivery Address	600 W ILLINOIS

Enter up to 35 items separated by commas.

Submit

Product Tracking & Reporting, All Rights Reserved  
Version: 26.3.2-864812dc

[Help](#)



# Product Tracking & Reporting

[Home](#)

[Search](#)

[Reports](#)

[Manual Entry](#)

[Rates/  
Commitments](#)

[PTR / EDW](#)

[Customer  
Information](#)

June 01, 2026

## USPS Tracking Intranet

### Delivery Signature and Address





1. Do not share information from this site outside of USPS. It is intended for USPS employee use only.
2. Employees may see some items with only event MT in the tracking record. This is an indication that the tracking number was part of problem where the USPS Label Creation API created the same label number multiple times. This led to a confusing tracking experience, so tracking has been suppressed. Reference this ticket for more info: INC000010676253, INC000010539853.

Tracking Number: 9414 8149 0236 8957 9358 25

JAVUENA PARTNERS

This item was delivered on 03/09/2026 at 14:25:00

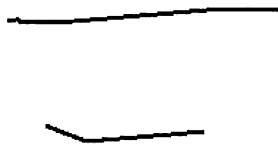
[< Return to Tracking Number View](#)

Signature	
Address	

Enter up to 35 items separated by commas.

Submit

Product Tracking & Reporting, All Rights Reserved  
Version: 26.3.2-864812dc



# Product Tracking & Reporting

Home

Search

Reports

Manual Entry

Rates/  
Commitments

PTR / EDW

Customer  
Information

June 01, 2026

## USPS Tracking Intranet

### Delivery Signature and Address



1. Do not share information from this site outside of USPS. It is intended for USPS employee use only.
2. Employees may see some items with only event MT in the tracking record. This is an indication that the tracking number was part of problem where the USPS Label Creation API created the same label number multiple times. This led to a confusing tracking experience, so tracking has been suppressed. Reference this ticket for more info: INC000010676253, INC000010539853.

Tracking Number: 9414 8149 0236 8957 9358 32

ZORRO PARTNERS LTD

This item was delivered on 03/09/2026 at 14:25:00

[< Return to Tracking Number View](#)

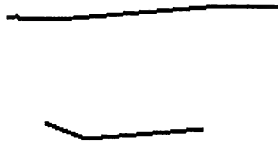
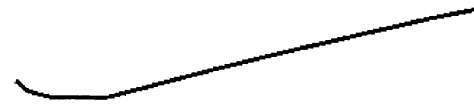
Signature	
Address	

Enter up to 35 items separated by commas.

Submit

[Help](#)



# Product Tracking & Reporting

[Home](#)

[Search](#)

[Reports](#)

[Manual Entry](#)

[Rates/  
Commitments](#)

[PTR / EDW](#)

[Customer  
Information](#)

June 01, 2026

## USPS Tracking Intranet

### Delivery Signature and Address



1. Do not share information from this site outside of USPS. It is intended for USPS employee use only.
2. Employees may see some items with only event MT in the tracking record. This is an indication that the tracking number was part of problem where the USPS Label Creation API created the same label number multiple times. This led to a confusing tracking experience, so tracking has been suppressed. Reference this ticket for more info: INC000010676253, INC000010539853.

Tracking Number: 9414 8149 0236 8957 9358 49

ADRIAN WYND DAVE

This item was delivered on 03/13/2026 at 11:48:00

[< Return to Tracking Number View](#)

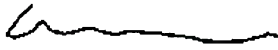
Signature	 ADRIAN WYND
Address	710 CL... ...

Enter up to 35 items separated by commas.

Submit

Product Tracking & Reporting, All Rights Reserved  
Version: 26.3.2-864812dc

[Help](#)



# Product Tracking & Reporting

[Home](#)  
 [Search](#)  
 [Reports](#)  
 [Manual Entry](#)  
 [Rates/Commitments](#)  
 [PTR / EDW](#)  
 [Customer Information](#)  
 June 01 2026

## USPS Tracking Intranet

### Delivery Signature and Address

 1. Do not share information from this site outside of USPS. It is intended for USPS employee use only.

2. Employees may see some items with only event MT in the tracking record. This is an indication that the tracking number was part of problem where the USPS Label Creation API created the same label number multiple times. This led to a confusing tracking experience, so tracking has been suppressed. Reference this ticket for more info: INC000010676253, INC000010539853.

Tracking Number: 9414 8149 0236 8957 9358 56

*PATSY MILLS BAKER EST TRUST*

This item was delivered on 03/10/2026 at 15:07:00

[< Return to Tracking Number View](#)

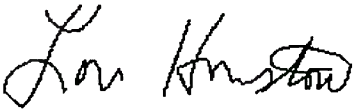
Signature	 Lori Howston
Address	<b>901 W 8TH ST</b>  <b>IDALOU, TX 79329-9058</b>

Enter up to 35 items separated by commas.

Submit

Product Tracking & Reporting, All Rights Reserved  
Version: 26.3.2-864812dc



# Product Tracking & Reporting

[Home](#)

[Search](#)

[Reports](#)

[Manual Entry](#)

[Rates/  
Commitments](#)

[PTR / EDW](#)

[Customer  
Information](#)

June 01, 2026

## USPS Tracking Intranet

### Delivery Signature and Address



1. Do not share information from this site outside of USPS. It is intended for USPS employee use only.
2. Employees may see some items with only event MT in the tracking record. This is an indication that the tracking number was part of problem where the USPS Label Creation API created the same label number multiple times. This led to a confusing tracking experience, so tracking has been suppressed. Reference this ticket for more info: INC000010676253, INC000010539853.

Tracking Number: 9414 8149 0236 8957 9358 63

PATSY MILLS BAKER 2005 CIST TRUST

This item was delivered on 03/10/2026 at 15:07:00

[< Return to Tracking Number View](#)

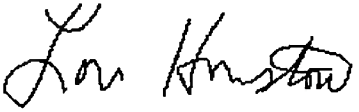
Signature	 Lori Howston
Address	<b>901 W 8TH ST</b>  <b>IDALOU, TX 79329-9058</b>

Enter up to 35 items separated by commas.

Submit





Product Tracking & Reporting



Home | Search | Reports | Manual Entry | System Administration | PER - EDW | Customer Information | Help

USPS Tracking Intranet

Delivery Signature and Address

1. Do not share information from this site outside of USPS. It is intended for USPS employee use only.

2. Employees may see some items with only event MT in the tracking record. This is an indication that the tracking number was part of a problem where the USPS Label Creation API created the same label number multiple times. This led to a confusing tracking experience, so tracking has been suppressed. Reference the ticket for more info: INC000010676253, INC000010539853.

RICHARD WARD  
KADUCHER

Tracking Number: 9414 8148 8236 8957 8358 84

This item was delivered on 03/07/2026 at 12:03:00

[Return to Tracking Number View](#)

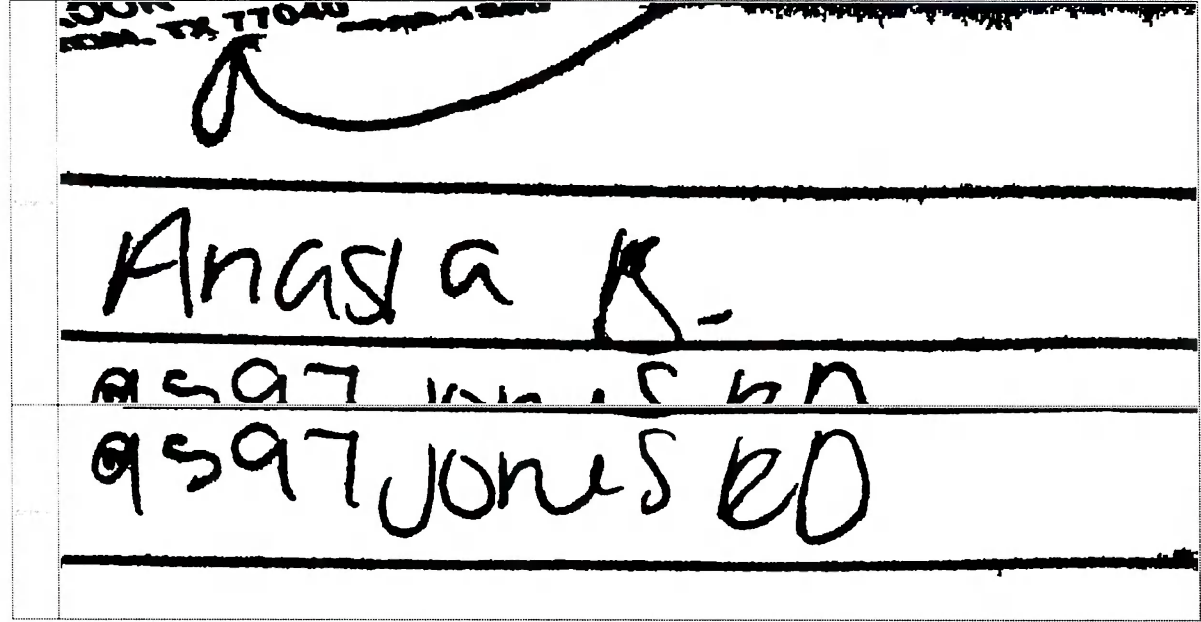

Enter up to 35 items separated by commas

Submit

Product Tracking & Reporting, All Rights Reserved  
Version: 26.3.2-864812dc

[Help](#)



# Product Tracking & Reporting

[Home](#)

[Search](#)

[Reports](#)

[Manual Entry](#)

[Rates/  
Commitments](#)

[PTR / EDW](#)

[Customer  
Information](#)

June 01, 2026

## USPS Tracking Intranet

### Delivery Signature and Address



1. Do not share information from this site outside of USPS. It is intended for USPS employee use only.

2. Employees may see some items with only event MT in the tracking record. This is an indication that the tracking number was part of problem where the USPS Label Creation API created the same label number multiple times. This led to a confusing tracking experience, so tracking has been suppressed. Reference this ticket for more info: INC000010676253, INC000010539853.

Tracking Number: 9414 8149 0236 8957 9359 00

ARD OIL LTD

This item was delivered on 03/07/2026 at 10:28:00

[< Return to Tracking Number View](#)

Signature	
Address	

Enter up to 35 items separated by commas.

Submit

Product Tracking & Reporting, All Rights Reserved  
Version: 26.3.2-864812dc

[Help](#)



# Product Tracking & Reporting

[Home](#)

[Search](#)

[Reports](#)

[Manual Entry](#)

[Rates/  
Commitments](#)

[PTR / EDW](#)

[Customer  
Information](#)

June 01, 2026

## USPS Tracking Intranet

### Delivery Signature and Address



1. Do not share information from this site outside of USPS. It is intended for USPS employee use only.
2. Employees may see some items with only event MT in the tracking record. This is an indication that the tracking number was part of problem where the USPS Label Creation API created the same label number multiple times. This led to a confusing tracking experience, so tracking has been suppressed. Reference this ticket for more info: INC000010676253, INC000010539853.

Tracking Number: 9414 8149 0236 8957 9359 17

PATRICIA BOYLE YOUNG TRUST  
ATTN BRANDON LONER

This item was delivered on 03/06/2026 at 09:09:00

[Return to Tracking Number View](#)

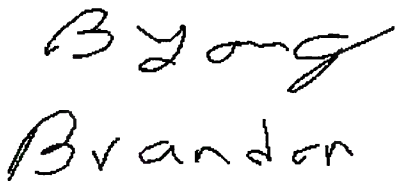
Signature	
Address	<p><b>PO BOX 1037</b></p> <p><b>OKMULGEE, OK 74447-1037</b></p>

Enter up to 35 items separated by commas.

Submit

Product Tracking & Reporting, All Rights Reserved  
Version: 26.3.2-864812dc

[Help](#)



# Product Tracking & Reporting

[Home](#)

[Search](#)

[Reports](#)

[Manual Entry](#)

[Rates/  
Commitments](#)

[PTR / EDW](#)

[Customer  
Information](#)

June 01, 2026

## USPS Tracking Intranet

### Delivery Signature and Address



1. Do not share information from this site outside of USPS. It is intended for USPS employee use only.
2. Employees may see some items with only event MT in the tracking record. This is an indication that the tracking number was part of problem where the USPS Label Creation API created the same label number multiple times. This led to a confusing tracking experience, so tracking has been suppressed. Reference this ticket for more info: INC000010676253, INC000010539853.

Tracking Number: 9414 8149 0236 8957 9359 24

ELLIOTT INDUSTRIES LP

This item was delivered on 03/16/2026 at 10:05:00

[Return to Tracking Number View](#)

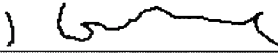
Signature	 
Address	1325

Enter up to 35 items separated by commas.

Submit

Product Tracking & Reporting, All Rights Reserved  
Version: 26.3.2-864812dc

[Help](#)



# Product Tracking & Reporting

[Home](#)

[Search](#)

[Reports](#)

[Manual Entry](#)

[Rates/  
Commitments](#)

[PTR / EDW](#)

[Customer  
Information](#)

June 01, 2026

## USPS Tracking Intranet

### Delivery Signature and Address





1. Do not share information from this site outside of USPS. It is intended for USPS employee use only.
2. Employees may see some items with only event MT in the tracking record. This is an indication that the tracking number was part of problem where the USPS Label Creation API created the same label number multiple times. This led to a confusing tracking experience, so tracking has been suppressed. Reference this ticket for more info: INC000010676253, INC000010539853.

Tracking Number: 9414 8149 0236 8957 9359 31

ELLIOTT HALL COMPANY

This item was delivered on 03/16/2026 at 10:05:00

[< Return to Tracking Number View](#)

Signature	 
Address	1723

Enter up to 35 items separated by commas.

Submit

Product Tracking & Reporting, All Rights Reserved  
Version: 26.3.2-864812dc

[Help](#)



# Product Tracking & Reporting

[Home](#)   
 [Search](#)   
 [Reports](#)   
 [Manual Entry](#)   
 [Rates/Commitments](#)   
 [PTR / EDW](#)   
 [Customer Information](#)   
 June 01, 2026

## USPS Tracking Intranet

### Delivery Signature and Address



1. Do not share information from this site outside of USPS. It is intended for USPS employee use only.

2. Employees may see some items with only event MT in the tracking record. This is an indication that the tracking number was part of problem where the USPS Label Creation API created the same label number multiple times. This led to a confusing tracking experience, so tracking has been suppressed. Reference this ticket for more info: INC000010676253, INC000010539853.

Tracking Number: 9414 8149 0236 8957 9359 48

NICHOLAS CLAY ANDERSON

This item was delivered on 03/12/2026 at 10:35:00

[< Return to Tracking Number View](#)

Signature	 NICK ANDERSON
Address	PO Box 1342 Sabinal, TX 78801

Enter up to 35 items separated by commas.

Submit

Product Tracking & Reporting, All Rights Reserved  
Version: 26.3.2-864812dc

Product Tracking & Reporting



Home | Search | Reports | Manual Entry | Data | Agreements | PIR | EDV | Claims | Information | Help

USPS Tracking Intranet

Delivery Signature and Address

1. Do not share information from this site outside of USPS. It is intended for USPS employee use only.  
2. Employees may see some items with only event MT in the tracking record. This is an indication that the tracking number was part of a problem where the USPS Label Creation API created the same label number multiple times. This led to a confusing tracking experience, so tracking has been suppressed. Reference the ticket for more info: INC000010676253, INC000010539853.

*[Handwritten signature]*  
*[Handwritten signature]*

BALONEY FEATHERS LTD

Tracking Number: 9414 8149 0238 8957 9359 55

This item was delivered on 03/06/2026 at 08:52:00

[Return to Tracking Number View](#)

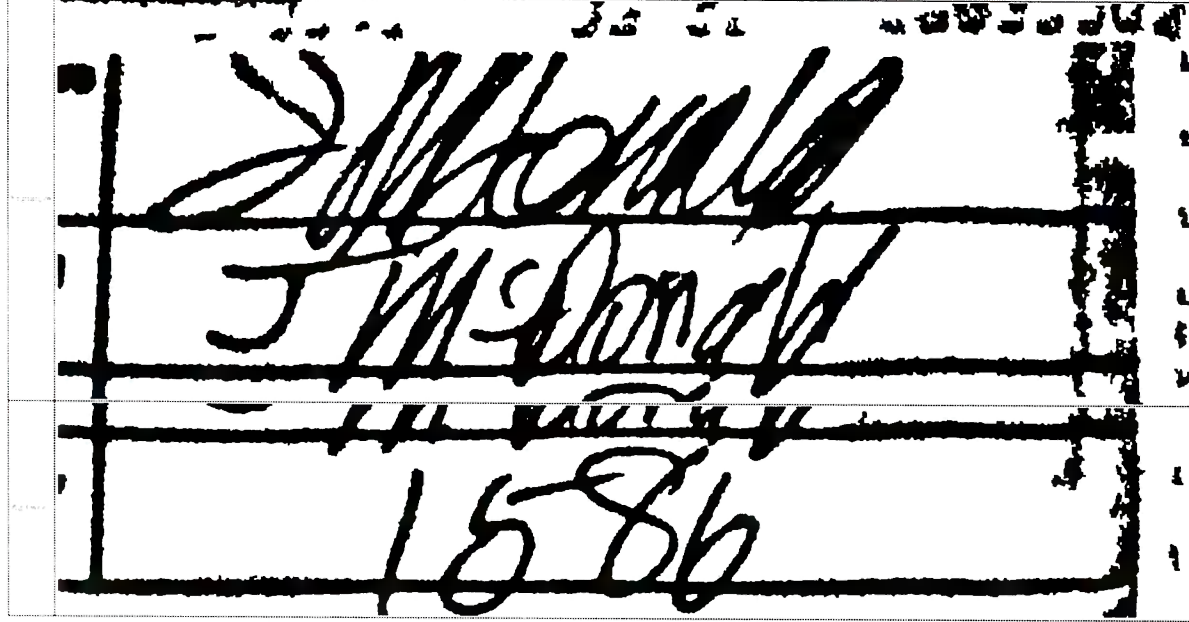

Enter up to 35 items separated by commas.

Submit

Product Tracking & Reporting. All Rights Reserved  
Version: 26.3.2-664812dc



# Product Tracking & Reporting

Home

Search

Reports

Manual Entry

Rates/  
Commitments

PTR / EDW

Customer  
Information

June 01, 2026

## USPS Tracking Intranet

### Delivery Signature and Address





- 1. Do not share information from this site outside of USPS. It is intended for USPS employee use only.
- 2. Employees may see some items with only event MT in the tracking record. This is an indication that the tracking number was part of problem where the USPS Label Creation API created the same label number multiple times. This led to a confusing tracking experience, so tracking has been suppressed. Reference this ticket for more info: INC000010676253, INC000010539853.

Tracking Number: 9414 8149 0236 8957 9359 62

JOSEPHINE T HUDSON TEST TR

This item was delivered on 03/09/2026 at 07:58:00

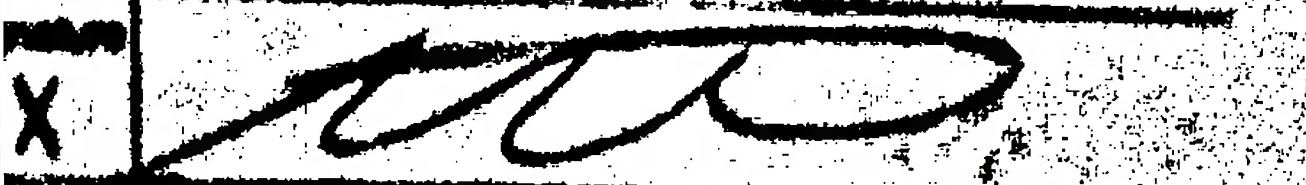
[Return to Tracking Number View](#)

Signature	
Address	

Enter up to 35 items separated by commas.

Submit

[Help](#)



# Product Tracking & Reporting

[Home](#)

[Search](#)

[Reports](#)

[Manual Entry](#)

[Rates/  
Commitments](#)

[PTR / EDW](#)

[Customer  
Information](#)

June 01, 2026

## USPS Tracking Intranet

### Delivery Signature and Address





1. Do not share information from this site outside of USPS. It is intended for USPS employee use only.
2. Employees may see some items with only event MT in the tracking record. This is an indication that the tracking number was part of problem where the USPS Label Creation API created the same label number multiple times. This led to a confusing tracking experience, so tracking has been suppressed. Reference this ticket for more info: INC000010676253, INC000010539853.

Tracking Number: 9414 8149 0236 8957 9359 79

JEWELLERS LEE TRUST

This item was delivered on 03/10/2026 at 12:33:00

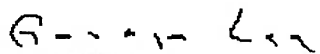
[< Return to Tracking Number View](#)

Signature	 
Address	

Enter up to 35 items separated by commas.

Submit

Product Tracking & Reporting, All Rights Reserved  
Version: 26.3.2-864812dc

Help



# Product Tracking & Reporting

Home

Search

Reports

Manual Entry

Rates/  
Commitments

PTR / EDW

Customer  
Information

June 01, 2026

## USPS Tracking Intranet

### Delivery Signature and Address



- 1. Do not share information from this site outside of USPS. It is intended for USPS employee use only.
- 2. Employees may see some items with only event MT in the tracking record. This is an indication that the tracking number was part of problem where the USPS Label Creation API created the same label number multiple times. This led to a confusing tracking experience, so tracking has been suppressed. Reference this ticket for more info: INC000010676253, INC000010539853.

Tracking Number: 9414 8149 0236 8957 9359 86

SLAYTON INVESTMENT LLC

This item was delivered on 03/12/2026 at 14:29:00

[Return to Tracking Number View](#)

Signature	
Address	<p><b>PO BOX 2035</b></p> <p><b>ROSWELL, NM 88202-2035</b></p>

Enter up to 35 items separated by commas.

Submit

Product Tracking & Reporting, All Rights Reserved  
Version: 26.3.2-864812dc

[Help](#)



# Product Tracking & Reporting

[Home](#)

[Search](#)

[Reports](#)

[Manual Entry](#)

[Rates/  
Commitments](#)

[PTR / EDW](#)

[Customer  
Information](#)

June 01 2026

## USPS Tracking Intranet

### Delivery Signature and Address



1. Do not share information from this site outside of USPS. It is intended for USPS employee use only.

2. Employees may see some items with only event MT in the tracking record. This is an indication that the tracking number was part of problem where the USPS Label Creation API created the same label number multiple times. This led to a confusing tracking experience, so tracking has been suppressed. Reference this ticket for more info: INC000010676253, INC000010539853.

Tracking Number: 9414 8149 0236 8957 9359 93

ROWA R HINKLE III

This item was delivered on 03/06/2026 at 10:08:00

[< Return to Tracking Number View](#)

Signature	
Address	

Enter up to 35 items separated by commas.

Submit

Product Tracking & Reporting, All Rights Reserved  
Version: 26.3.2-864812dc

Help



# Product Tracking & Reporting

Home

Search

Reports

Manual Entry

Rates/  
Commitments

PTR / EDW

Customer  
Information

June 01, 2026

## USPS Tracking Intranet

### Delivery Signature and Address



1. Do not share information from this site outside of USPS. It is intended for USPS employee use only.
2. Employees may see some items with only event MT in the tracking record. This is an indication that the tracking number was part of problem where the USPS Label Creation API created the same label number multiple times. This led to a confusing tracking experience, so tracking has been suppressed. Reference this ticket for more info: INC000010676253, INC000010539853.

Tracking Number: 9414 8149 0236 8957 9360 06

PENASCO PETROLEUM LLC

This item was delivered on 03/06/2026 at 10:08:00

[< Return to Tracking Number View](#)

Signature	A Moody
Address	7292

Enter up to 35 items separated by commas.

Submit

Product Tracking & Reporting, All Rights Reserved  
Version: 26.3.2-864812dc

Help



# Product Tracking & Reporting

Home

Search

Reports

Manual Entry

Rates/  
Commitments

PTR / EDW

Customer  
Information

June 01 2026

## USPS Tracking Intranet

### Delivery Signature and Address



1. Do not share information from this site outside of USPS. It is intended for USPS employee use only.
2. Employees may see some items with only event MT in the tracking record. This is an indication that the tracking number was part of problem where the USPS Label Creation API created the same label number multiple times. This led to a confusing tracking experience, so tracking has been suppressed. Reference this ticket for more info: INC000010676253, INC000010539853.

Tracking Number: 9414 8149 0236 8957 9360 13

MCMULLEN MINERALS LLC

This item was delivered on 03/07/2026 at 07:58:00

[< Return to Tracking Number View](#)

Signature	
Address	

Enter up to 35 items separated by commas.

Submit

Product Tracking & Reporting, All Rights Reserved  
Version: 26.3.2-864812dc



# Product Tracking & Reporting

[Home](#)

[Search](#)

[Reports](#)

[Manual Entry](#)

[Rates/  
Commitments](#)

[PTR / EDW](#)

[Customer  
Information](#)

June 01, 2026

## USPS Tracking Intranet

### Delivery Signature and Address

 1. Do not share information from this site outside of USPS. It is intended for USPS employee use only.

2. Employees may see some items with only event MT in the tracking record. This is an indication that the tracking number was part of problem where the USPS Label Creation API created the same label number multiple times. This led to a confusing tracking experience, so tracking has been suppressed. Reference this ticket for more info: INC000010676253, INC000010539853.

Tracking Number: 9414 8149 0236 8957 9360 20

JOHN & THERESA HUMAN  
FAMILY

This item was delivered on 03/11/2026 at 10:01:00

[Return to Tracking Number View](#)

Signature	
	Printed Name Candy Copeland
Address	Delivery Address 50187

Enter up to 35 items separated by commas.

Submit

Help



# Product Tracking & Reporting

Home

Search

Reports

Manual Entry

Rates/  
Commitments

PTR / EDW

Customer  
Information

June 01, 2026

## USPS Tracking Intranet

### Delivery Signature and Address



- 1. Do not share information from this site outside of USPS. It is intended for USPS employee use only.
- 2. Employees may see some items with only event MT in the tracking record. This is an indication that the tracking number was part of problem where the USPS Label Creation API created the same label number multiple times. This led to a confusing tracking experience, so tracking has been suppressed. Reference this ticket for more info: INC000010676253, INC000010539853.

Tracking Number: 9414 8149 0236 8957 9360 37

MARSHALL & WINSTON INC

This item was delivered on 03/04/2026 at 10:37:00

[< Return to Tracking Number View](#)

Signature	Signature <b>X</b>	B Rimerca
	Printed Name	B RIMERCA
Address	Delivery Address	50880

Enter up to 35 items separated by commas.

Submit

Product Tracking & Reporting, All Rights Reserved  
Version: 26.3.2-864812dc

Help



# Product Tracking & Reporting

Home

Search

Reports

Manual Entry

Rates/  
Commitments

PTR / EDW

Customer  
Information

June 01, 2026

## USPS Tracking Intranet

### Delivery Signature and Address



1. Do not share information from this site outside of USPS. It is intended for USPS employee use only.
2. Employees may see some items with only event MT in the tracking record. This is an indication that the tracking number was part of problem where the USPS Label Creation API created the same label number multiple times. This led to a confusing tracking experience, so tracking has been suppressed. Reference this ticket for more info: INC000010676253, INC000010539853.

Tracking Number: 9414 8149 0236 8957 9360 44

HORTON ROYALTY LP

This item was delivered on 03/05/2026 at 11:43:00

[< Return to Tracking Number View](#)

Delivery Section					
Signature	<table border="1"> <tr> <td>Signature X</td> <td></td> </tr> <tr> <td>Printed Name</td> <td>Robert Horton</td> </tr> </table>	Signature X		Printed Name	Robert Horton
Signature X					
Printed Name	Robert Horton				
Address	<table border="1"> <tr> <td>Delivery Address</td> <td></td> </tr> </table>	Delivery Address			
Delivery Address					

Enter up to 35 items separated by commas.

Submit

Product Tracking & Reporting, All Rights Reserved  
Version: 26.3.2-864812dc

Help



# Product Tracking & Reporting

Home

Search

Reports

Manual Entry

Rates/  
Commitments

PTR / EDW

Customer  
Information

June 01 2026

## USPS Tracking Intranet

### Delivery Signature and Address



- 1. Do not share information from this site outside of USPS. It is intended for USPS employee use only.
- 2. Employees may see some items with only event MT in the tracking record. This is an indication that the tracking number was part of problem where the USPS Label Creation API created the same label number multiple times. This led to a confusing tracking experience, so tracking has been suppressed. Reference this ticket for more info: INC000010676253, INC000010539853.

Tracking Number: 9414 8149 0236 8957 9360 51

DUNCAN MANAGEMENT LLC AGENT

This item was delivered on 03/14/2026 at 16:15:00

[< Return to Tracking Number View](#)

Signature	Printed Name	Kelly L. King
	Delivery Address	Kelly L. Lawry
Address	P.O. Box 671099, Dallas, TX	

Enter up to 35 items separated by commas.

Submit

Product Tracking & Reporting, All Rights Reserved  
Version: 26.3.2-864812dc

Help



# Product Tracking & Reporting

Home

Search

Reports

Manual Entry

Rates/  
Commitments

PTR / EDW

Customer  
Information

June 01, 2026

## USPS Tracking Intranet

### Delivery Signature and Address



1. Do not share information from this site outside of USPS. It is intended for USPS employee use only.

2. Employees may see some items with only event MT in the tracking record. This is an indication that the tracking number was part of problem where the USPS Label Creation API created the same label number multiple times. This led to a confusing tracking experience, so tracking has been suppressed. Reference this ticket for more info: INC000010676253, INC000010539853.

Tracking Number: 9414 8149 0236 8957 9360 68

PECTUSUS RESOURCES II LLC

This item was delivered on 03/08/2026 at 06:47:00

[< Return to Tracking Number View](#)

<b>Delivery Section</b>					
Signature	<table border="1"> <tr> <td style="width: 150px;"><b>Signature</b> X</td> <td></td> </tr> <tr> <td><b>Printed Name</b></td> <td>DAVID ANASTAS</td> </tr> </table>	<b>Signature</b> X		<b>Printed Name</b>	DAVID ANASTAS
<b>Signature</b> X					
<b>Printed Name</b>	DAVID ANASTAS				
Address	<b>Delivery Address</b>				

Enter up to 35 items separated by commas.

Submit

Product Tracking & Reporting, All Rights Reserved  
Version: 26.3.2-864812dc

[Help](#)



# Product Tracking & Reporting

[Home](#)

[Search](#)

[Reports](#)

[Manual Entry](#)

[Rates/  
Commitments](#)

[PTR / EDW](#)

[Customer  
Information](#)

June 01, 2026

## USPS Tracking Intranet

### Delivery Signature and Address



1. Do not share information from this site outside of USPS. It is intended for USPS employee use only.
2. Employees may see some items with only event MT in the tracking record. This is an indication that the tracking number was part of problem where the USPS Label Creation API created the same label number multiple times. This led to a confusing tracking experience, so tracking has been suppressed. Reference this ticket for more info: INC000010676253, INC000010539853.

Tracking Number: 9414 8149 0236 8957 9360 75

PEGIUSUS RESOURCES LLC

This item was delivered on 03/08/2026 at 06:47:00

[< Return to Tracking Number View](#)

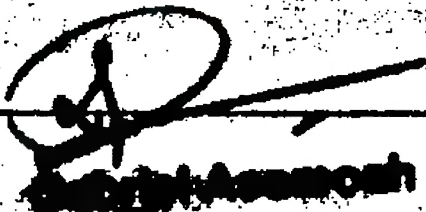
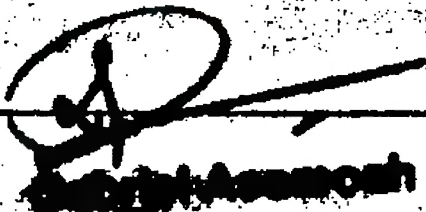
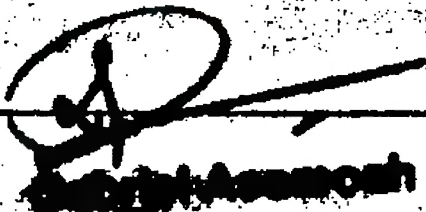
<b>Delivery Section</b>				
Signature	<table border="1"> <tr> <td style="width: 150px;"><b>Signature</b> X</td> <td rowspan="2" style="text-align: center; vertical-align: middle;">  </td> </tr> <tr> <td><b>Printed Name</b></td> </tr> </table>	<b>Signature</b> X		<b>Printed Name</b>
<b>Signature</b> X				
<b>Printed Name</b>				
Address	<table border="1"> <tr> <td style="width: 150px;"><b>Delivery Address</b></td> <td></td> </tr> </table>	<b>Delivery Address</b>		
<b>Delivery Address</b>				

Enter up to 35 items separated by commas.

Submit

Product Tracking & Reporting, All Rights Reserved  
Version: 26.3.2-864812dc



# Product Tracking & Reporting

Home

Search

Reports

Manual Entry

Rates/  
Commitments

PTR / EDW

Customer  
Information

June 01, 2026

## USPS Tracking Intranet

### Delivery Signature and Address



- 1. Do not share information from this site outside of USPS. It is intended for USPS employee use only.
- 2. Employees may see some items with only event MT in the tracking record. This is an indication that the tracking number was part of problem where the USPS Label Creation API created the same label number multiple times. This led to a confusing tracking experience, so tracking has been suppressed. Reference this ticket for more info: INC000010676253, INC000010539853.

Tracking Number: 9414 8149 0236 8957 9360 82

DELMAR HUDSON LEWIS LUV TRUST

This item was delivered on 03/08/2026 at 06:42:00

[< Return to Tracking Number View](#)

Delivery Section	
Signature	<div style="border: 1px solid black; padding: 5px;"> <p><b>Signature</b></p> <p>X </p> </div>
Printed Name	<div style="border: 1px solid black; padding: 5px;"> <p><b>Printed Name</b></p> <p>KISSA BAKER</p> </div>
Address	<div style="border: 1px solid black; padding: 5px;"> <p><b>Delivery Address</b></p> <p>K. BAKER</p> </div>

Enter up to 35 items separated by commas.

Submit



# Product Tracking & Reporting

Home

Search

Reports

Manual Entry

Rates/  
Commitments

PTR / EDW

Customer  
Information

June 01, 2026

## USPS Tracking Intranet

### Delivery Signature and Address



1. Do not share information from this site outside of USPS. It is intended for USPS employee use only.
2. Employees may see some items with only event MT in the tracking record. This is an indication that the tracking number was part of problem where the USPS Label Creation API created the same label number multiple times. This led to a confusing tracking experience, so tracking has been suppressed. Reference this ticket for more info: INC000010676253, INC000010539853.

Tracking Number: 9414 8149 0236 8957 9360 99

CTAM 0911 LLC

This item was delivered on 03/09/2026 at 04:34:00

[< Return to Tracking Number View](#)

	Delivery Section	
Signature	Signature	
	Printed Name	John Amodeo
Address	Delivery Address	76191 - 76199 - 76198

Enter up to 35 items separated by commas.

Submit

Help



# Product Tracking & Reporting

Home

Search

Reports

Manual Entry

Rates/  
Commitments

PTR / EDW

Customer  
Information

June 01, 2026

## USPS Tracking Intranet

### Delivery Signature and Address



1. Do not share information from this site outside of USPS. It is intended for USPS employee use only.
2. Employees may see some items with only event MT in the tracking record. This is an indication that the tracking number was part of problem where the USPS Label Creation API created the same label number multiple times. This led to a confusing tracking experience, so tracking has been suppressed. Reference this ticket for more info: INC000010676253, INC000010539853.

Tracking Number: 9414 8149 0236 8957 9361 05

GC 09/01/26

This item was delivered on 03/09/2026 at 04:34:00

[< Return to Tracking Number View](#)

Delivery Section					
Signature	<table border="1"> <tr> <td style="width: 150px;">Signature</td> <td>X</td> </tr> <tr> <td>Printed Name</td> <td>Greg Amos</td> </tr> </table>	Signature	X	Printed Name	Greg Amos
Signature	X				
Printed Name	Greg Amos				
Address	<table border="1"> <tr> <td style="width: 150px;">Delivery Address</td> <td>76191 - 76199 - 76198</td> </tr> </table>	Delivery Address	76191 - 76199 - 76198		
Delivery Address	76191 - 76199 - 76198				

Enter up to 35 items separated by commas.

Submit

Product Tracking & Reporting, All Rights Reserved  
Version: 26.3.2-864812dc

Help



# Product Tracking & Reporting

Home

Search

Reports

Manual Entry

Rates/  
Commitments

PTR / EDW

Customer  
Information

June 01, 2026

## USPS Tracking Intranet

### Delivery Signature and Address



1. Do not share information from this site outside of USPS. It is intended for USPS employee use only.

2. Employees may see some items with only event MT in the tracking record. This is an indication that the tracking number was part of problem where the USPS Label Creation API created the same label number multiple times. This led to a confusing tracking experience, so tracking has been suppressed. Reference this ticket for more info: INC000010676253, INC000010539853.

Tracking Number: 9414 8149 0236 8957 9354 43

BRODERICK JOINT REVOCABLE TRUST

This item was delivered on 03/11/2026 at 13:07:00

[Return to Tracking Number View](#)

	<b>Delivery Section</b>	
Signature	<b>Signature</b>	<i>[Handwritten Signature]</i>
	<b>Printed Name</b>	<i>DENISE BRODERICK</i>
Address	<b>Delivery Address</b>	<i>1029 SW 8th Circle</i>

Enter up to 35 items separated by commas.

Submit

Product Tracking & Reporting, All Rights Reserved  
Version: 26.3.2-864812dc

[Help](#)



# Product Tracking & Reporting

[Home](#)   
 [Search](#)   
 [Reports](#)   
 [Manual Entry](#)   
 [Rates/Commitments](#)   
 [PTR / EDW](#)   
 [Customer Information](#)   
 June 01, 2026

## USPS Tracking Intranet

### Delivery Signature and Address



1. Do not share information from this site outside of USPS. It is intended for USPS employee use only.
2. Employees may see some items with only event MT in the tracking record. This is an indication that the tracking number was part of a problem where the USPS Label Creation API created the same label number multiple times. This led to a confusing tracking experience, so tracking has been suppressed. Reference this ticket for more info: INC000010676253, INC000010539853.

Tracking Number: 9414 8149 0236 8957 9354 43

BRODERICK JOINT REVOCABLE TRUST

This item was delivered on 03/11/2026 at 13:07:00

[Return to Tracking Number View](#)

<b>Delivery Section</b>	
Signature	<p><b>Signature</b></p> 
Address	<p><b>Printed Name</b></p> <p>Denise Broderick</p> <p><b>Delivery Address</b></p> <p>1029 SW 8th Circle</p>

Enter up to 35 items separated by commas.

Submit

Product Tracking & Reporting, All Rights Reserved  
Version: 26.3.2-864812dc



# Product Tracking & Reporting

Home

Search

Reports

Manual Entry

Rates/  
Commitments

PTR / EDW

Customer  
Information

June 01, 2026

## USPS Tracking Intranet

### Delivery Signature and Address



1. Do not share information from this site outside of USPS. It is intended for USPS employee use only.
2. Employees may see some items with only event MT in the tracking record. This is an indication that the tracking number was part of problem where the USPS Label Creation API created the same label number multiple times. This led to a confusing tracking experience, so tracking has been suppressed. Reference this ticket for more info: INC000010676253, INC000010539853.

Tracking Number: 9414 8149 0236 8957 9354 50

CROFT LIVING TRUST

This item was delivered on 03/12/2026 at 16:45:00

KATIE ELIZABETH CROFT CO TTEE

[Return to Tracking Number View](#)

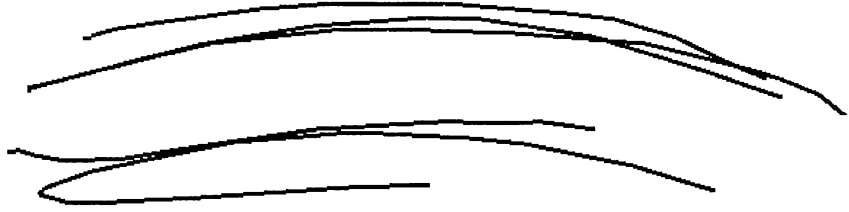
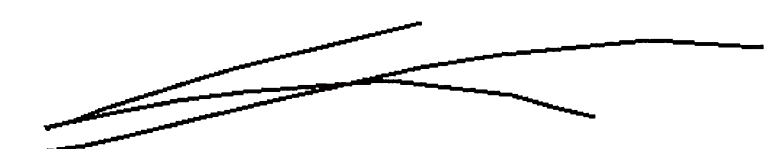
Signature	
Address	

Enter up to 35 items separated by commas.

Submit



# Product Tracking & Reporting

Home

Search

Reports

Manual Entry

Rates/  
Commitments

PTR / EDW

Customer  
Information

June 01 2026

## USPS Tracking Intranet

### Delivery Signature and Address







1. Do not share information from this site outside of USPS. It is intended for USPS employee use only.
2. Employees may see some items with only event MT in the tracking record. This is an indication that the tracking number was part of problem where the USPS Label Creation API created the same label number multiple times. This led to a confusing tracking experience, so tracking has been suppressed. Reference this ticket for more info: INC000010676253, INC000010539853.

Tracking Number: 9414 8149 0236 8957 9354 67

WEST BEND ENERGY PARTNERS LLC

This item was delivered on 03/09/2026 at 15:51:00

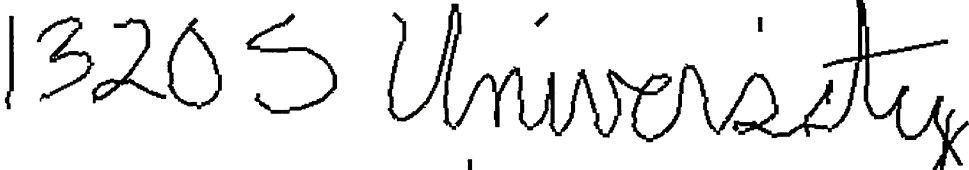
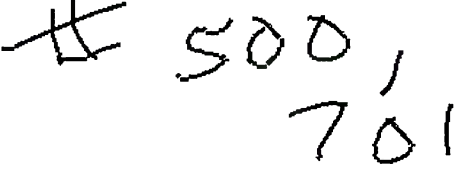
[Return to Tracking Number View](#)

Signature	 
Address	  

Enter up to 35 items separated by commas.

Submit

[Help](#)



# Product Tracking & Reporting

[Home](#)

[Search](#)

[Reports](#)

[Manual Entry](#)

[Rates/  
Commitments](#)

[PTR / EDW](#)

[Customer  
Information](#)

June 01, 2026

## USPS Tracking Intranet

### Delivery Signature and Address



1. Do not share information from this site outside of USPS. It is intended for USPS employee use only.
2. Employees may see some items with only event MT in the tracking record. This is an indication that the tracking number was part of problem where the USPS Label Creation API created the same label number multiple times. This led to a confusing tracking experience, so tracking has been suppressed. Reference this ticket for more info: INC000010676253, INC000010539853.

Tracking Number: 9414 8149 0236 8957 9354 74

THERESIA ANN BRODERICK

This item was delivered on 03/09/2026 at 18:46:00

[< Return to Tracking Number View](#)

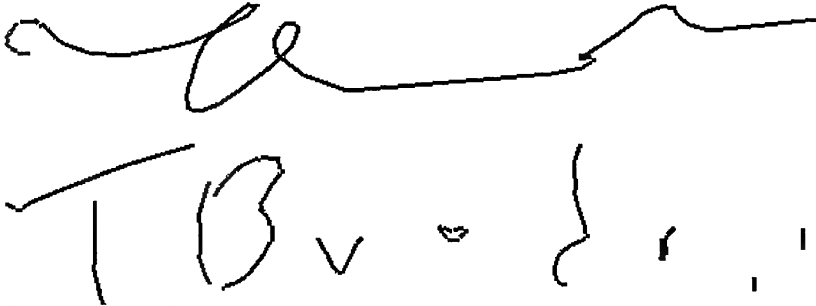
Signature	
Address	<p><b>1371 SW HEARTWOOD DR, LEES SUMMIT, MO 64081</b></p>

Enter up to 35 items separated by commas.

Submit

Product Tracking & Reporting, All Rights Reserved  
Version: 26.3.2-864812dc



# Product Tracking & Reporting

Home

Search

Reports

Manual Entry

Rates/  
Commitments

PTR / EDW

Customer  
Information

June 01 2026

## USPS Tracking Intranet

### Delivery Signature and Address



1. Do not share information from this site outside of USPS. It is intended for USPS employee use only.
2. Employees may see some items with only event MT in the tracking record. This is an indication that the tracking number was part of problem where the USPS Label Creation API created the same label number multiple times. This led to a confusing tracking experience, so tracking has been suppressed. Reference this ticket for more info: INC000010676253, INC000010539853.

Tracking Number: 9414 8149 0236 8957 9354 81

ROBERT E LEE HALL JR

This item was delivered on 03/09/2026 at 13:41:00

[< Return to Tracking Number View](#)

Signature	<i>Robert Hall Jr</i>
Address	<p><b>1397 WINTER CAMP TRL</b></p> <p><b>HEDGESVILLE, WV 25427-5361</b></p>

Enter up to 35 items separated by commas.

Submit

[Help](#)



# Product Tracking & Reporting

[Home](#)

[Search](#)

[Reports](#)

[Manual Entry](#)

[Rates/  
Commitments](#)

[PTR / EDW](#)

[Customer  
Information](#)

June 03 2026

## USPS Tracking Intranet

### Delivery Signature and Address



1. Do not share information from this site outside of USPS. It is intended for USPS employee use only.
2. Employees may see some items with only event MT in the tracking record. This is an indication that the tracking number was part of problem where the USPS Label Creation API created the same label number multiple times. This led to a confusing tracking experience, so tracking has been suppressed. Reference this ticket for more info: INC000010676253, INC000010539853.

Tracking Number: 9414 8149 0236 8957 9354 98

SITIOI PERMIAN LP

This item was delivered on 03/24/2026 at 08:28:00

[< Return to Tracking Number View](#)

Delivery Section					
Signature	<table border="1"> <tr> <td>Signature X</td> <td><i>[Handwritten Signature]</i></td> </tr> <tr> <td>Printed Name</td> <td><i>M. Berry</i></td> </tr> </table>	Signature X	<i>[Handwritten Signature]</i>	Printed Name	<i>M. Berry</i>
Signature X	<i>[Handwritten Signature]</i>				
Printed Name	<i>M. Berry</i>				
Address	<table border="1"> <tr> <td>Delivery Address</td> <td><i>5505 <del>Alameda</del> St *</i></td> </tr> </table>	Delivery Address	<i>5505 <del>Alameda</del> St *</i>		
Delivery Address	<i>5505 <del>Alameda</del> St *</i>				

Enter up to 35 items separated by commas.

Submit

Product Tracking & Reporting, All Rights Reserved  
Version: 26.3.2-864812dc

[Help](#)



# Product Tracking & Reporting

[Home](#)

[Search](#)

[Reports](#)

[Manual Entry](#)

[Rates/  
Commitments](#)

[PTR / EDW](#)

[Customer  
Information](#)

June 01 2026

## USPS Tracking Intranet

### Delivery Signature and Address



1. Do not share information from this site outside of USPS. It is intended for USPS employee use only.
2. Employees may see some items with only event MT in the tracking record. This is an indication that the tracking number was part of problem where the USPS Label Creation API created the same label number multiple times. This led to a confusing tracking experience, so tracking has been suppressed. Reference this ticket for more info: INC000010676253, INC000010539853.

Tracking Number: 9414 8149 0236 8957 9355 04

**ROBERT CHARLES ABBOTT**

This item was delivered on 03/10/2026 at 14:45:00

[< Return to Tracking Number View](#)

Signature	<b>Signature</b> X	
	<b>Printed Name</b>	
Address	<b>Delivery Address</b>	

Enter up to 35 items separated by commas.

Submit

Product Tracking & Reporting, All Rights Reserved  
Version: 26.3.2-864812dc



# Product Tracking & Reporting

Home

Search

Reports

Manual Entry

Rates/  
Commitments

PTR / EDW

Customer  
Information

June 01 2026

## USPS Tracking Intranet

### Delivery Signature and Address



- 1. Do not share information from this site outside of USPS. It is intended for USPS employee use only.
- 2. Employees may see some items with only event MT in the tracking record. This is an indication that the tracking number was part of problem where the USPS Label Creation API created the same label number multiple times. This led to a confusing tracking experience, so tracking has been suppressed. Reference this ticket for more info: INC000010676253, INC000010539853.

Tracking Number: 9414 8149 0236 8957 9355 11

LAURA AND JOHN ARNOLD  
FOUNDATION

This item was delivered on 03/09/2026 at 15:32:00

[Return to Tracking Number View](#)

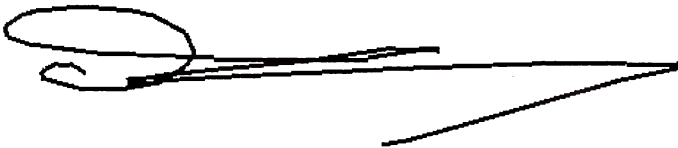
Signature	 
Address	<p>1717 W. LOOP, A1800</p>

Enter up to 35 items separated by commas.

Submit

[Help](#)



# Product Tracking & Reporting

[Home](#)

[Search](#)

[Reports](#)

[Manual Entry](#)

[Rates/  
Commitments](#)

[PTR / EDW](#)

[Customer  
Information](#)

June 01, 2026

## USPS Tracking Intranet

### Delivery Signature and Address



1. Do not share information from this site outside of USPS. It is intended for USPS employee use only.

2. Employees may see some items with only event MT in the tracking record. This is an indication that the tracking number was part of problem where the USPS Label Creation API created the same label number multiple times. This led to a confusing tracking experience, so tracking has been suppressed. Reference this ticket for more info: INC000010676253, INC000010539853.

Tracking Number: 9414 8149 0236 8957 9355 28

JEMISON ANN MAGUIRE

This item was delivered on 03/07/2026 at 11:33:00

[< Return to Tracking Number View](#)

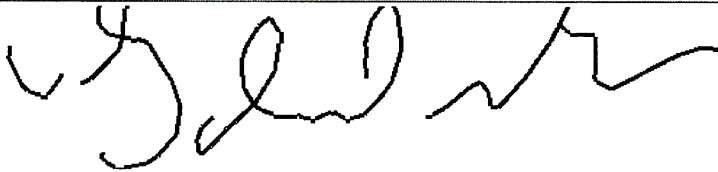
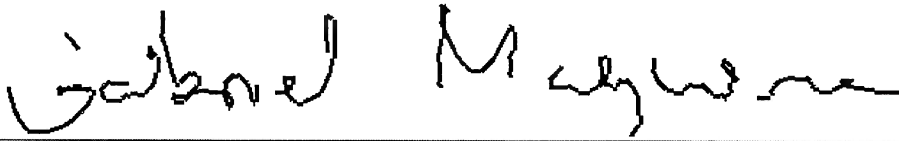
Signature	 
Address	<p><b>1916 TUFTON CT, VIRGINIA BEACH, VA 23454</b></p>

Enter up to 35 items separated by commas.

Submit

Product Tracking & Reporting, All Rights Reserved  
Version: 26.3.2-864812dc

[Help](#)



# Product Tracking & Reporting

[Home](#)

[Search](#)

[Reports](#)

[Manual Entry](#)

[Rates/  
Commitments](#)

[PTR / EDW](#)

[Customer  
Information](#)

June 01, 2026

## USPS Tracking Intranet

### Delivery Signature and Address



1. Do not share information from this site outside of USPS. It is intended for USPS employee use only.



2. Employees may see some items with only event MT in the tracking record. This is an indication that the tracking number was part of problem where the USPS Label Creation API created the same label number multiple times. This led to a confusing tracking experience, so tracking has been suppressed. Reference this ticket for more info: INC000010676253, INC000010539853.

Tracking Number: 9414 8149 0236 8957 9355 35

ROY G BARTON JR

This item was delivered on 03/06/2026 at 11:00:00

[Return to Tracking Number View](#)

Signature	 
Address	

Enter up to 35 items separated by commas.

Submit

Product Tracking & Reporting, All Rights Reserved  
Version: 26.3.2-864812dc

[Help](#)



# Product Tracking & Reporting

[Home](#)

[Search](#)

[Reports](#)

[Manual Entry](#)

[Rates/  
Commitments](#)

[PTR / EDW](#)

[Customer  
Information](#)

June 01, 2026

## USPS Tracking Intranet

### Delivery Signature and Address



- 1. Do not share information from this site outside of USPS. It is intended for USPS employee use only.
- 2. Employees may see some items with only event MT in the tracking record. This is an indication that the tracking number was part of problem where the USPS Label Creation API created the same label number multiple times. This led to a confusing tracking experience, so tracking has been suppressed. Reference this ticket for more info: INC000010676253, INC000010539853.

Tracking Number: 9414 8149 0236 8957 9355 42

KATHLEEN L GEORGE

This item was delivered on 05/04/2026 at 09:37:00

RETURNED TO MCO

[Return to Tracking Number View](#)

<b>Delivery Section</b>					
Signature	<table border="1"> <tr> <td>Signature</td> <td><i>Sarah Lynn</i></td> </tr> <tr> <td>Printed Name</td> <td>Sarah Lynn</td> </tr> </table>	Signature	<i>Sarah Lynn</i>	Printed Name	Sarah Lynn
	Signature	<i>Sarah Lynn</i>			
Printed Name	Sarah Lynn				
Address	<table border="1"> <tr> <td>Delivery Address</td> <td>3617 N Big Spring</td> </tr> </table>	Delivery Address	3617 N Big Spring		
Delivery Address	3617 N Big Spring				

Enter up to 35 items separated by commas.

Submit

Product Tracking & Reporting, All Rights Reserved  
Version: 26.3.2-864812dc

[Help](#)



# Product Tracking & Reporting

[Home](#)

[Search](#)

[Reports](#)

[Manual Entry](#)

[Rates/  
Commitments](#)

[PTR / EDW](#)

[Customer  
Information](#)

June 01, 2026

## USPS Tracking Intranet

### Delivery Signature and Address



1. Do not share information from this site outside of USPS. It is intended for USPS employee use only.
2. Employees may see some items with only event MT in the tracking record. This is an indication that the tracking number was part of problem where the USPS Label Creation API created the same label number multiple times. This led to a confusing tracking experience, so tracking has been suppressed. Reference this ticket for more info: INC000010676253, INC000010539853.

Tracking Number: 9414 8149 0236 8957 9355 59

RICHARD DONALD JONES JR

This item was delivered on 03/11/2026 at 11:31:00

[< Return to Tracking Number View](#)

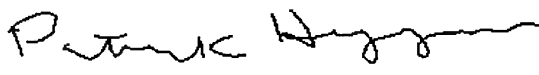
Signature	 Patrick Higgins
Address	<p style="text-align: center;"><b>200 N GAINES RD</b></p> <p style="text-align: center;">CEDAR CREEK, TX 78612-3167</p>

Enter up to 35 items separated by commas.

Submit

Product Tracking & Reporting, All Rights Reserved  
Version: 26.3.2-864812dc

Product Tracking & Reporting



Home Search Reports Manual Entry Tools Governmental PERFORM Chatbot Information Help

USPS Tracking Intranet  
Delivery Signature and Address

1. Do not share information from this site outside of USPS. It is intended for USPS employee use only.  
2. Employees may see some items with only event MT in the tracking record. This is an indication that the tracking number was part of problem where the USPS Label Creation API created the same label number multiple times. This led to a confusing tracking experience, so tracking has been suppressed. Reference this ticket for more info. INC000010676253, INC000010539853.

BRETT EVERETT  
LONGMEY TRUST

Tracking Number: 9414 8149 8238 8957 9355 86

This item was delivered on 03/08/2026 at 14:29:00

[Return to Tracking Number View](#)

Marie Conley
Marie C
2002 Oxford

Enter up to 35 items separated by commas

Submit

Product Tracking & Reporting. All Rights Reserved  
Version: 26.12-664812dc

Product Tracking & Reporting



Home Search Reports Manual Entry Rate of Performance Metrics Information

USPS Tracking Intranet

Delivery Signature and Address

1. Do not share information from this site outside of USPS. It is intended for USPS employee use only.
2. Employees may see some items with only event MT in the tracking record. This is an indication that the tracking number was part of a problem where the USPS Label Creation API created the same label number multiple times. This led to a confusing tracking experience, so tracking has been suppressed. Reference this ticket for more info: INC000010676253, INC000010539853.

WILLIAM JOSEPH LONGHEM TRUST

Tracking Number: 9414 8148 8238 8957 8355 73

This item was delivered on 03/09/2026 at 14:38:00

Return to Tracking Number View

Handwritten signature and address: Marie Conley, Marie Co, 2002 Oxford

Enter up to 35 items separated by commas

Submit

Product Tracking & Reporting, All Rights Reserved
Version: 26 3 2-864812dc

Product Tracking & Reporting



USPS Tracking Intranet  
Delivery Signature and Address

2016 SAMANTHA BASS  
PAM TR

1. Do not share information from this site outside of USPS. It is intended for USPS employee use only.  
2. Employees may see some items with only event MT in the tracking record. This is an indication that the tracking number was part of a problem where the USPS Label Creation API created the same label number multiple times. This led to a confusing tracking experience, so tracking has been suppressed. Reference this ticket for more info. INC000010676253, INC000010539853.

Tracking Number: 9414 8148 0238 8957 8355 80

This item was delivered on 03/09/2026 at 11:34:08

[Return to Tracking Number View](#)

Enter up to 35 items separated by commas

Submit

Product Tracking & Reporting. All Rights Reserved  
Version: 26.3.2-864812dc



# Product Tracking & Reporting

[Home](#)

[Search](#)

[Reports](#)

[Manual Entry](#)

[Rates/  
Commitments](#)

[PTR / EDW](#)

[Customer  
Information](#)

June 01, 2026

## USPS Tracking Intranet

### Delivery Signature and Address



1. Do not share information from this site outside of USPS. It is intended for USPS employee use only.
2. Employees may see some items with only event MT in the tracking record. This is an indication that the tracking number was part of problem where the USPS Label Creation API created the same label number multiple times. This led to a confusing tracking experience, so tracking has been suppressed. Reference this ticket for more info: INC000010676253, INC000010539853.

Tracking Number: 9414 8149 0236 8957 9355 97

PIVOTAL ROYALTIES PARTNERS LP

This item was delivered on 05/04/2026 at 12:12:00

[< Return to Tracking Number View](#)

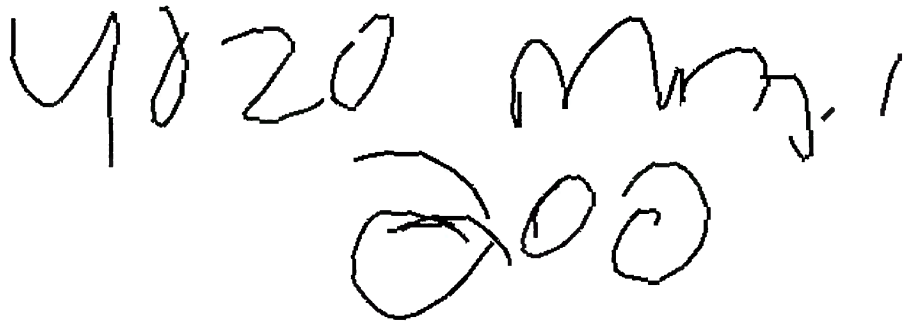
Signature	
Address	

Enter up to 35 items separated by commas.

Submit

[Help](#)



# Product Tracking & Reporting

[Home](#)

[Search](#)

[Reports](#)

[Manual Entry](#)

[Rates/  
Commitments](#)

[PTR / EDW](#)

[Customer  
Information](#)

June 01, 2026

## USPS Tracking Intranet

### Delivery Signature and Address



1. Do not share information from this site outside of USPS. It is intended for USPS employee use only.
2. Employees may see some items with only event MT in the tracking record. This is an indication that the tracking number was part of problem where the USPS Label Creation API created the same label number multiple times. This led to a confusing tracking experience, so tracking has been suppressed. Reference this ticket for more info: INC000010676253, INC000010539853.

Tracking Number: 9414 8149 0236 8957 9356 03

DIANE MARY TRUITT

This item was delivered on 03/07/2026 at 12:20:00

[< Return to Tracking Number View](#)

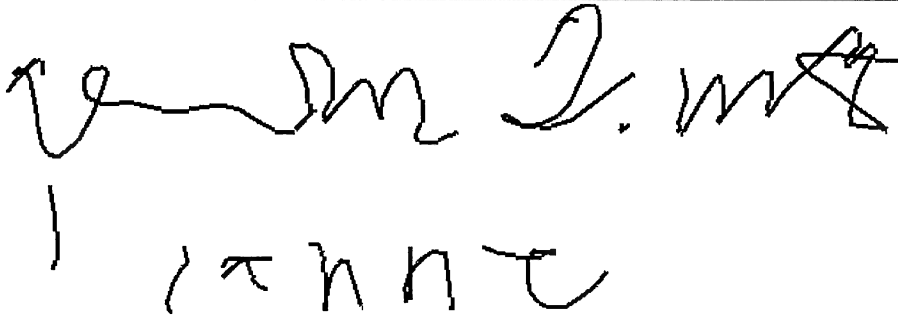
Signature	
Address	<p><b>20230 ATASCOCITA LAKE DR, HUMBLE, TX 77346</b></p>

Enter up to 35 items separated by commas.

Submit

Product Tracking & Reporting, All Rights Reserved  
Version: 26.3.2-864812dc

Help



# Product Tracking & Reporting

Home

Search

Reports

Manual Entry

Rates/  
Commitments

PTR / EDW

Customer  
Information

June 01, 2026

## USPS Tracking Intranet

### Delivery Signature and Address



1. Do not share information from this site outside of USPS. It is intended for USPS employee use only.

2. Employees may see some items with only event MT in the tracking record. This is an indication that the tracking number was part of problem where the USPS Label Creation API created the same label number multiple times. This led to a confusing tracking experience, so tracking has been suppressed. Reference this ticket for more info: INC000010676253, INC000010539853.

Tracking Number: 9414 8149 0236 8957 9356 10

JAMES E KAUCHER

This item was delivered on 03/09/2026 at 12:51:00

[< Return to Tracking Number View](#)

Signature	 Kaucher
Address	20602 Laverfon

Enter up to 35 items separated by commas.

Submit

Product Tracking & Reporting, All Rights Reserved  
Version: 26.3.2-864812dc

[Help](#)



# Product Tracking & Reporting

[Home](#)

[Search](#)

[Reports](#)

[Manual Entry](#)

[Rates/  
Commitments](#)

[PTR / EDW](#)

[Customer  
Information](#)

June 01 2026

## USPS Tracking Intranet

### Delivery Signature and Address



1. Do not share information from this site outside of USPS. It is intended for USPS employee use only.

2. Employees may see some items with only event MT in the tracking record. This is an indication that the tracking number was part of problem where the USPS Label Creation API created the same label number multiple times. This led to a confusing tracking experience, so tracking has been suppressed. Reference this ticket for more info: INC000010676253, INC000010539853.

Tracking Number: 9414 8149 0236 8957 9356 27

LINDYS LIU TR

This item was delivered on 03/07/2026 at 12:46:00

[< Return to Tracking Number View](#)

Delivery Section	
Signature	<p><b>X</b></p> <p>215 [Signature]</p>
Printed Name	215 L
Address	[Redacted]

Enter up to 35 items separated by commas.

Submit

Product Tracking & Reporting, All Rights Reserved  
Version: 26.3.2-864812dc

Help



# Product Tracking & Reporting

Home

Search

Reports

Manual Entry

Rates/  
Commitments

PTR / EDW

Customer  
Information

June 01, 2026

## USPS Tracking Intranet

### Delivery Signature and Address



1. Do not share information from this site outside of USPS. It is intended for USPS employee use only.

2. Employees may see some items with only event MT in the tracking record. This is an indication that the tracking number was part of problem where the USPS Label Creation API created the same label number multiple times. This led to a confusing tracking experience, so tracking has been suppressed. Reference this ticket for more info: INC000010676253, INC000010539853.

Tracking Number: 9414 8149 0236 8957 9356 34

DEVICE CANELL BROWERICK

This item was delivered on 03/25/2026 at 09:46:00

RETURNED TO MCO

FWD EXPIRED

[Return to Tracking Number View](#)

Signature	<input checked="" type="checkbox"/> Signature	Surah Leyva
	<input type="checkbox"/> Print Name	Surah Leyva
Address	<input type="checkbox"/> Delivery Address	3617 N Big Spring

Enter up to 35 items separated by commas.

Submit

Product Tracking & Reporting, All Rights Reserved  
Version: 26.3.2-864812dc

[Help](#)



# Product Tracking & Reporting

[Home](#)

[Search](#)

[Reports](#)

[Manual Entry](#)

[Rates/  
Commitments](#)

[PTR / EDW](#)

[Customer  
Information](#)

June 01, 2026

## USPS Tracking Intranet

### Delivery Signature and Address



1. Do not share information from this site outside of USPS. It is intended for USPS employee use only.
2. Employees may see some items with only event MT in the tracking record. This is an indication that the tracking number was part of problem where the USPS Label Creation API created the same label number multiple times. This led to a confusing tracking experience, so tracking has been suppressed. Reference this ticket for more info: INC000010676253, INC000010539853.



Tracking Number: 9414 8149 0236 8957 9356 41



BUREAU OF LAND  
MANAGEMENT

This item was delivered on 03/06/2026 at 12:10:00

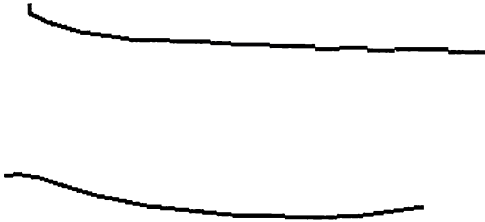
[< Return to Tracking Number View](#)

Signature	
Address	

Enter up to 35 items separated by commas.

Submit

Product Tracking & Reporting, All Rights Reserved  
Version: 26.3.2-864812dc

[Help](#)



# Product Tracking & Reporting

[Home](#)

[Search](#)

[Reports](#)

[Manual Entry](#)

[Rates/  
Commitments](#)

[PTR / EDW](#)

[Customer  
Information](#)

June 01, 2026

## USPS Tracking Intranet

### Delivery Signature and Address



1. Do not share information from this site outside of USPS. It is intended for USPS employee use only.
2. Employees may see some items with only event MT in the tracking record. This is an indication that the tracking number was part of problem where the USPS Label Creation API created the same label number multiple times. This led to a confusing tracking experience, so tracking has been suppressed. Reference this ticket for more info: INC000010676253, INC000010539853.

Tracking Number: 9414 8149 0236 8957 9356 58

NEW MEXICO COMMISSIONER  
OF NEW MEXICO STATE LAND OFFICE

This item was delivered on 03/09/2026 at 07:59:00

[Return to Tracking Number View](#)

Signature	<b>Signature</b> X	
	<b>Printed Name</b>	Marcus A. Bavela
Address	<b>Delivery Address</b>	1148

94148149023689579356

Submit

Product Tracking & Reporting, All Rights Reserved  
Version: 26.3.2-864812dc

Help



# Product Tracking & Reporting

Home

Search

Reports

Manual Entry

Rates/  
Commitments

PTR / EDW

Customer  
Information

June 01 2026

## USPS Tracking Intranet

### Delivery Signature and Address



1. Do not share information from this site outside of USPS. It is intended for USPS employee use only.
2. Employees may see some items with only event MT in the tracking record. This is an indication that the tracking number was part of problem where the USPS Label Creation API created the same label number multiple times. This led to a confusing tracking experience, so tracking has been suppressed. Reference this ticket for more info: INC000010676253, INC000010539853.

Tracking Number: 9414 8149 0236 8957 9356 65

WOODLANDS VENTURE CAPITAL COMPANY

This item was delivered on 03/09/2026 at 07:28:00

[< Return to Tracking Number View](#)

Signature	<p><b>Delivery Section</b></p> <p>Signature X <i>[Handwritten Signature]</i></p> <p>Printed Name <i>[Handwritten Name]</i></p>
	<p>Address</p> <p>Delivery Address <i>[Handwritten Address]</i></p>

Enter up to 35 items separated by commas.

Submit

Product Tracking & Reporting, All Rights Reserved  
Version: 26.3.2-864812dc

[Help](#)



# Product Tracking & Reporting

[Home](#)

[Search](#)

[Reports](#)

[Manual Entry](#)

[Rates/  
Commitments](#)

[PTR / EDW](#)

[Customer  
Information](#)

June 01, 2026

## USPS Tracking Intranet

### Delivery Signature and Address



1. Do not share information from this site outside of USPS. It is intended for USPS employee use only.

2. Employees may see some items with only event MT in the tracking record. This is an indication that the tracking number was part of problem where the USPS Label Creation API created the same label number multiple times. This led to a confusing tracking experience, so tracking has been suppressed. Reference this ticket for more info: INC000010676253, INC000010539853.

Tracking Number: 9414 8149 0236 8957 9356 72

ROBERT PETER KAUCHER

This item was delivered on 03/06/2026 at 13:48:00

[Return to Tracking Number View](#)

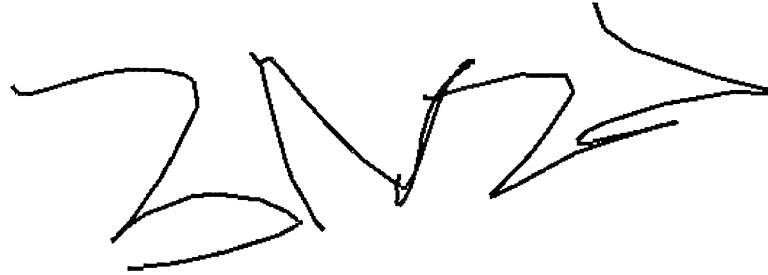
Signature	
Address	

Enter up to 35 items separated by commas.

Submit

Product Tracking & Reporting, All Rights Reserved  
Version: 26.3.2-864812dc

[Help](#)



# Product Tracking & Reporting

[Home](#)

[Search](#)

[Reports](#)

[Manual Entry](#)

[Rates/  
Commitments](#)

[PTR / EDW](#)

[Customer  
Information](#)

June 01, 2026

## USPS Tracking Intranet

### Delivery Signature and Address



1. Do not share information from this site outside of USPS. It is intended for USPS employee use only.
2. Employees may see some items with only event MT in the tracking record. This is an indication that the tracking number was part of problem where the USPS Label Creation API created the same label number multiple times. This led to a confusing tracking experience, so tracking has been suppressed. Reference this ticket for more info: INC000010676253, INC000010539853.

Tracking Number: 9414 8149 0236 8957 9356 89

RICHARD LEE HALL

This item was delivered on 03/07/2026 at 13:42:00

[< Return to Tracking Number View](#)

Signature	
Address	<p><b>3519 GLEN LOCH CT, ROCKINGHAM, VA 22801</b></p>

Enter up to 35 items separated by commas.

Submit

Product Tracking & Reporting, All Rights Reserved  
Version: 26.3.2-864812dc



# Product Tracking & Reporting

[Home](#)

[Search](#)

[Reports](#)

[Manual Entry](#)

[Rates/  
Commitments](#)

[PTR / EDW](#)

[Customer  
Information](#)

June 01, 2026

## USPS Tracking Intranet

### Delivery Signature and Address





1. Do not share information from this site outside of USPS. It is intended for USPS employee use only.
2. Employees may see some items with only event MT in the tracking record. This is an indication that the tracking number was part of problem where the USPS Label Creation API created the same label number multiple times. This led to a confusing tracking experience, so tracking has been suppressed. Reference this ticket for more info: INC000010676253, INC000010539853.

Tracking Number: 9414 8149 0236 8957 9357 19

THE ALLEN FAMILY REV TRUST

This item was delivered on 03/07/2026 at 17:04:00

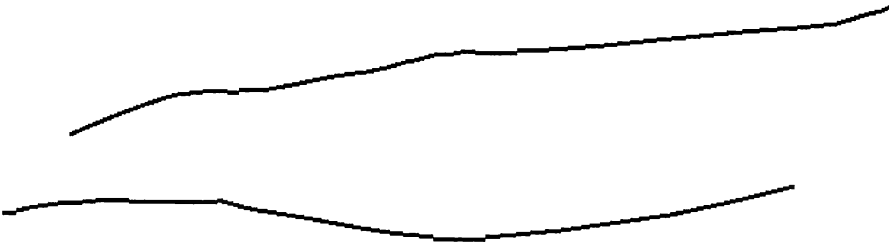
[< Return to Tracking Number View](#)

Signature	
Address	

Enter up to 35 items separated by commas.

Submit



# Product Tracking & Reporting

[Home](#)

[Search](#)

[Reports](#)

[Manual Entry](#)

[Rates/  
Commitments](#)

[PTR / EDW](#)

[Customer  
Information](#)

June 01, 2026

## USPS Tracking Intranet

### Delivery Signature and Address





1. Do not share information from this site outside of USPS. It is intended for USPS employee use only.
2. Employees may see some items with only event MT in the tracking record. This is an indication that the tracking number was part of problem where the USPS Label Creation API created the same label number multiple times. This led to a confusing tracking experience, so tracking has been suppressed. Reference this ticket for more info: INC000010676253, INC000010539853.

Tracking Number: 9414 8149 0236 8957 9357 26

ALLEN FPM REV TRUST DTD  
05/19/00 NANLY EDGUE

This item was delivered on 03/07/2026 at 17:03:00

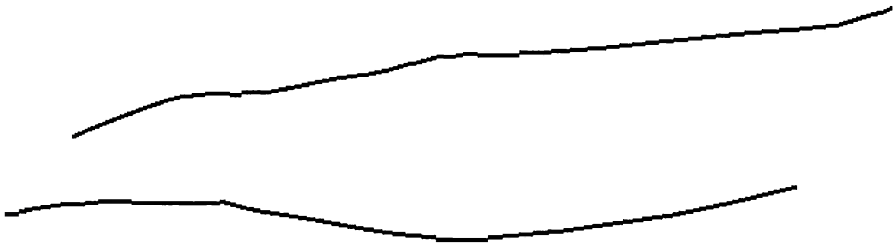
[Return to Tracking Number View](#)

Signature	
Address	

Enter up to 35 items separated by commas.

Submit



# Product Tracking & Reporting

Home

Search

Reports

Manual Entry

Rates/  
Commitments

PTR / EDW

Customer  
Information

June 01, 2026

## USPS Tracking Intranet

### Delivery Signature and Address



1. Do not share information from this site outside of USPS. It is intended for USPS employee use only.
2. Employees may see some items with only event MT in the tracking record. This is an indication that the tracking number was part of problem where the USPS Label Creation API created the same label number multiple times. This led to a confusing tracking experience, so tracking has been suppressed. Reference this ticket for more info: INC000010676253, INC000010539853.

Tracking Number: 9414 8149 0236 8957 9357 33

PUMA MINERAL PARTNERS LLC

This item was delivered on 03/09/2026 at 13:34:00

[Return to Tracking Number View](#)

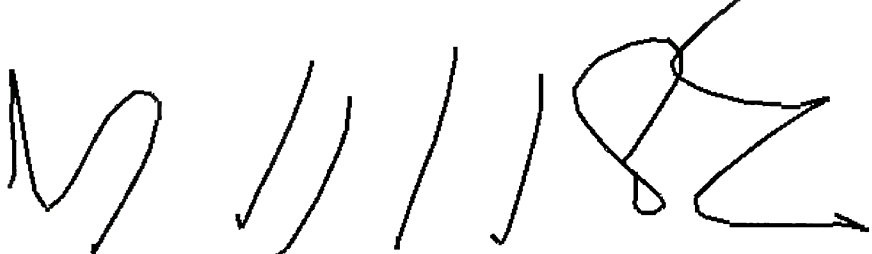
Signature	
Address	

Enter up to 35 items separated by commas.

Submit

Product Tracking & Reporting



Home | Sign In | Reporting | Manual Entry | Data | Customer Information | Settings

USPS Tracking Intranet

Delivery Signature and Address

SMP TITAN FLEX LP

- 1. Do not share information from this site outside of USPS. It is intended for USPS employee use only.
- 2. Employees may see some items with only event MT in the tracking record. This is an indication that the tracking number was part of a problem where the USPS Label Creation API created the same label number multiple times. This led to a confusing tracking experience, so tracking has been suppressed. Reference to a ticket for more info: INC000010676253, INC000010539853.

Tracking Number: 9414 8146 8236 8957 8357 40

This item was delivered on 03/09/2026 at 13:17:00

[Return to Tracking Number View](#)

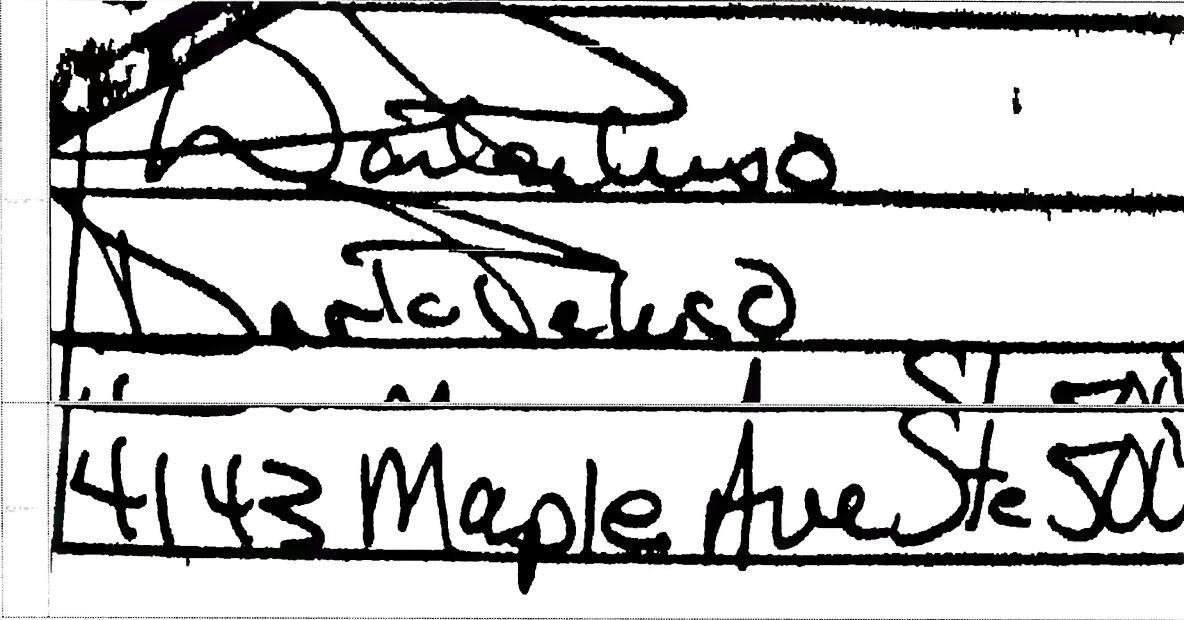

Enter up to 35 items separated by commas

Submit

Product Tracking & Reporting. All Rights Reserved  
Version: 26.3.2-864812dc

Product Tracking & Reporting



Home | Reports | Manual Entry | Tools | Data | Other | Data | Customer Information | Settings

USPS Tracking Intranet

Delivery Signature and Address

1. Do not share information from this site outside of USPS. It is intended for USPS employee use only.

2. Employees may see some items with only event MT in the tracking record. This is an indication that the tracking number was part of a problem where the USPS Label Creation API created the same label number multiple times. This led to a confusing tracking experience, so tracking has been suppressed. Reference this ticket for more info. INC000010676253 INC000010539853

MSH FAM REAL EST  
PRTNSP II LLC

Tracking Number: 9414 8149 8236 8957 9357 97

This item was delivered on 03/09/2026 at 13:18:00

[Return to Tracking Number View](#)

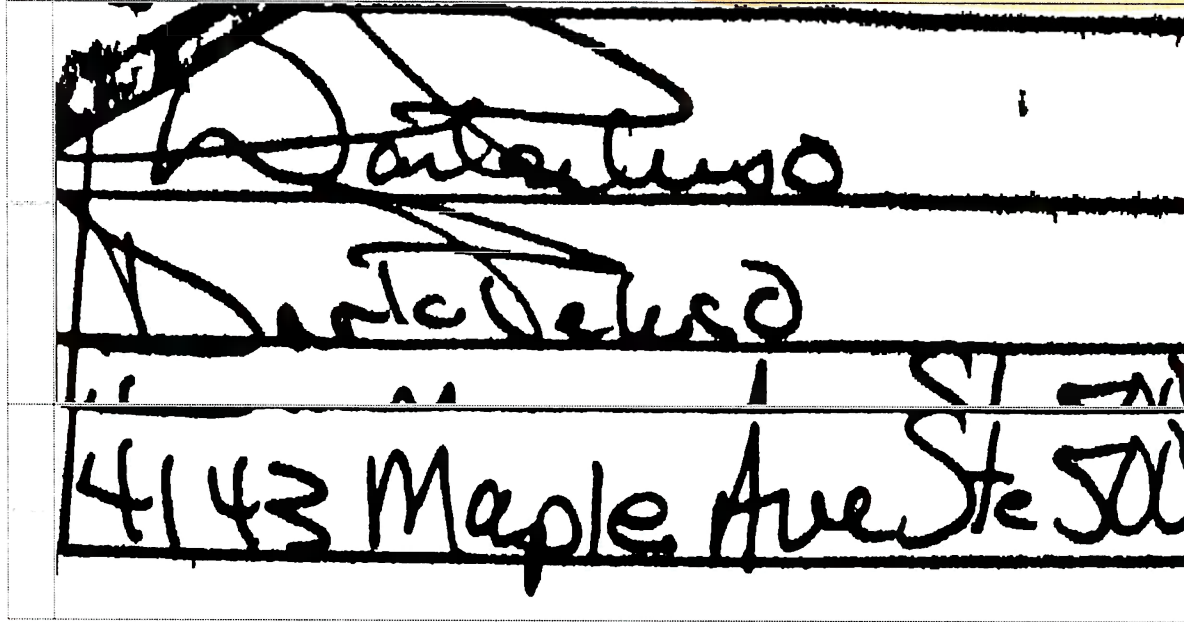

Enter up to 35 items separated by commas.

Submit

Product Tracking & Reporting. All Rights Reserved  
Version: 26.32-864812dc

Product Tracking & Reporting



USPS Tracking Intranet

Delivery Signature and Address

SMP PATRIOT MINERAL HOLDINGS LLC

- 1. Do not share information from this site outside of USPS. It is intended for USPS employee use only.
- 2. Employees may see some items with only event MT in the tracking record. This is an indication that the tracking number was part of a problem where the USPS Label Creation API created the same label number multiple times. This led to a confusing tracking experience, so tracking has been suppressed. Reference this ticket for more info. INC000010676253, INC000010539853.

Tracking Number: 9414 8149 0238 8957 8357 64

This item was delivered on 03/09/2026 at 13:18:00

[Return to Tracking Number View](#)

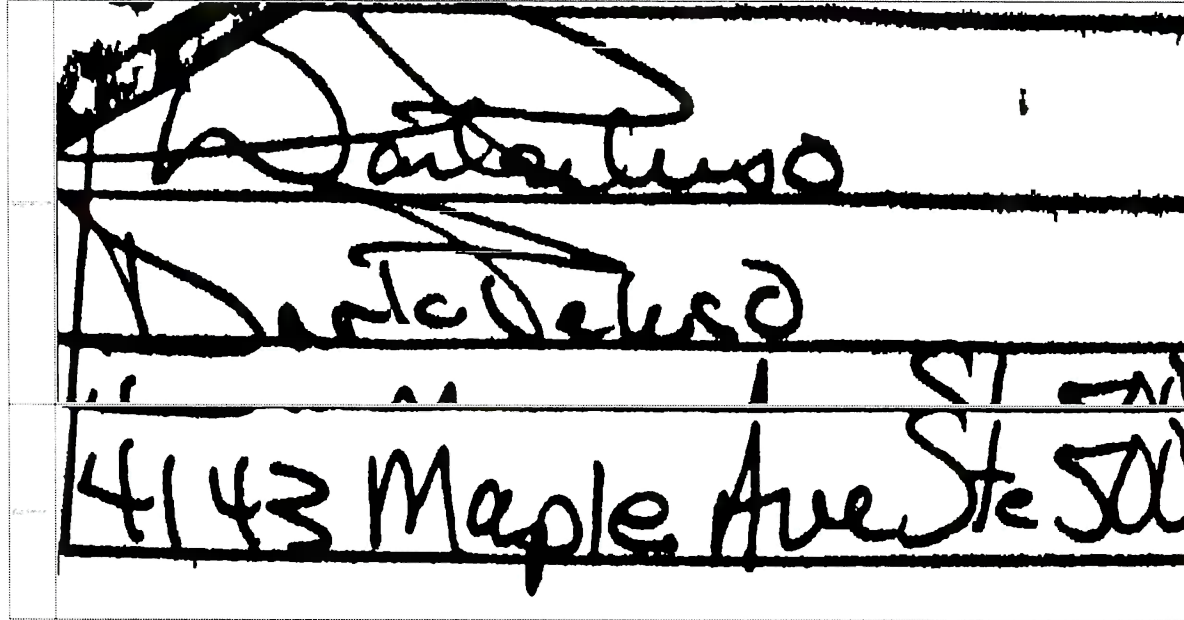

Enter up to 35 items separated by commas

Submit

Product Tracking & Reporting, All Rights Reserved  
Version: 26.32-864812dc

Product Tracking & Reporting



Home | My Profile | My Mail Items | My Packages | My Shipments | My Labels | My Tracking | My Reports

USPS Tracking Intranet

Delivery Signature and Address

1. Do not share information from this site outside of USPS. It is intended for USPS employee use only.  
2. Employees may see some items with only event MT in the tracking record. This is an indication that the tracking number was part of a problem where the USPS Label Creation API created the same label number multiple times. This led to a confusing tracking experience, so tracking has been suppressed. Reference this ticket for more info: INC000010676253, INC000010539853.

SMP SIDECAR  
TITAN

Tracking Number: 9414 8148 8238 8957 8337 71

This item was delivered on 03/09/2026 at 13:17:00

[Return to Tracking Number View](#)

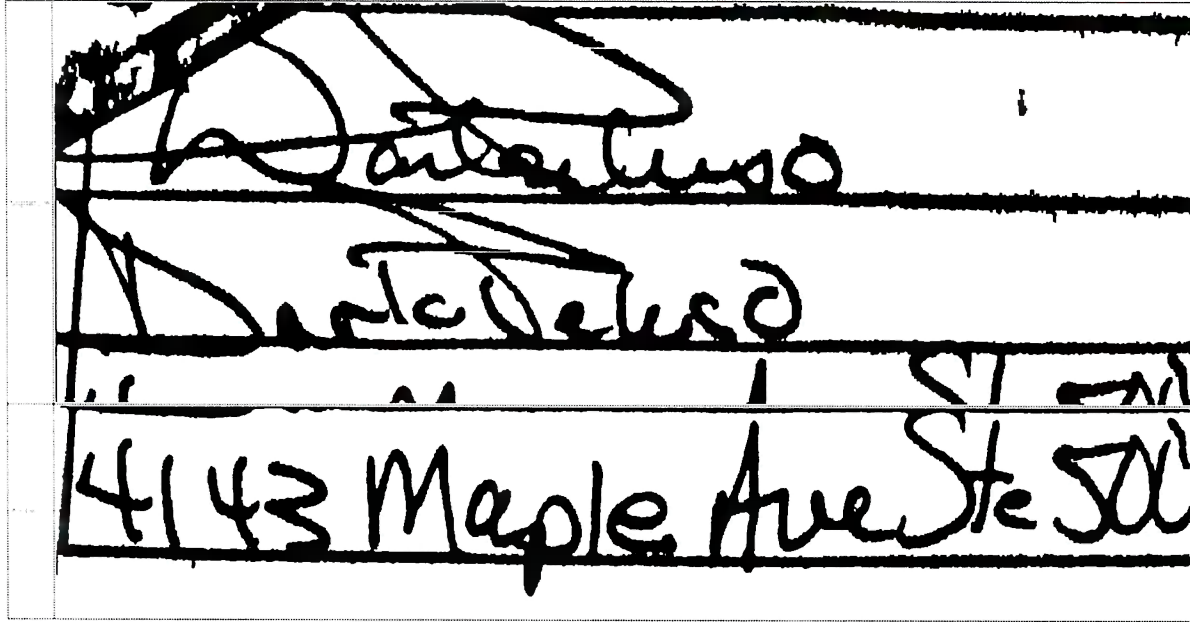

Enter up to 35 items separated by commas.

Submit

Product Tracking & Reporting, All Rights Reserved  
Version: 26.3.2-864812dc

Product Tracking & Reporting



Home Search Metrics Manual Entry **PERF** Government PIR / EDW Customer Information

USPS Tracking Intranet

Delivery Signature and Address

- 1. Do not share information from this site outside of USPS. It is intended for USPS employee use only.
- 2. Employees may see some items with only event MT in the tracking record. This is an indication that the tracking number was part of a problem where the USPS Label Creation API created the same label number multiple times. This led to a confusing tracking experience, so tracking has been suppressed. Reference this ticket for more info. INC000010676253, INC000010539853.

SMP TITAN MINERAL

Tracking Number: 9414 8149 8236 8957 8357 88

This item was delivered on 03/09/2026 at 13:18:06

[Return to Tracking Number View](#)

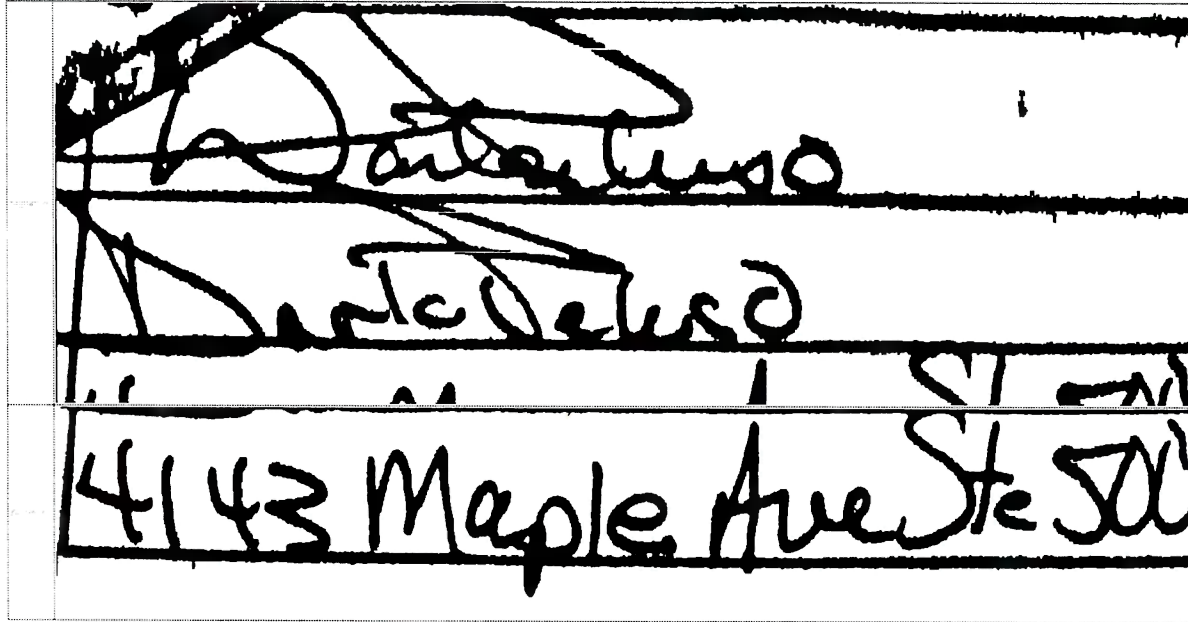

Enter up to 35 items separated by commas.

Submit

Product Tracking & Reporting. All Rights Reserved  
Version: 26.3.2-864812dc



# Product Tracking & Reporting

[Home](#)

[Search](#)

[Reports](#)

[Manual Entry](#)

[Rates/  
Commitments](#)

[PTR / EDW](#)

[Customer  
Information](#)

June 01, 2026

## USPS Tracking Intranet

### Delivery Signature and Address

 1. Do not share information from this site outside of USPS. It is intended for USPS employee use only.

2. Employees may see some items with only event MT in the tracking record. This is an indication that the tracking number was part of problem where the USPS Label Creation API created the same label number multiple times. This led to a confusing tracking experience, so tracking has been suppressed. Reference this ticket for more info: INC000010676253, INC000010539853.

Tracking Number: 9414 8149 0236 8957 9357 95

ROSS BRODERICK

This item was delivered on 03/24/2026 at 09:21:00

RETURNED TO MCO

[Return to Tracking Number View](#)

Delivery Section	
Signature	<b>Signature</b> X Sarah Leyva
	<b>Printed Name</b> Sarah Leyva
Address	<b>Delivery Address</b> 3617 N Big Spring

Enter up to 35 items separated by commas.

Submit

Product Tracking & Reporting



USPS Tracking Intranet  
Delivery Signature and Address

- 1. Do not share information from this site outside of USPS. It is intended for USPS employee use only.
- 2. Employees may see some items with only event NT in the tracking record. This is an indication that the tracking number was part of a problem where the USPS Label Creation API created the same label number multiple times. This led to a confusing tracking experience, so tracking has been suppressed. Reference this ticket for more info: INC000010676253, INC000010538853.

WRS ENTERPRISES INC

Tracking Number: 9414 8149 9238 8997 9358 01

This item was delivered on 03/07/2026 at 13:38:00

[Return to Tracking Number View](#)

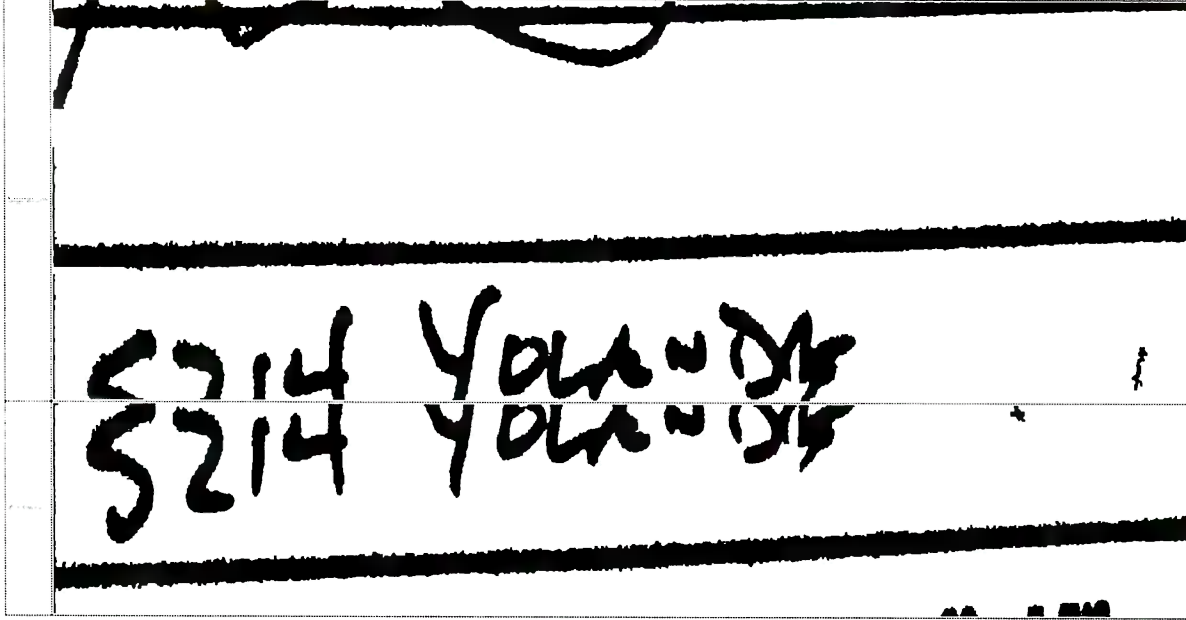

Enter up to 35 items separated by commas.

Submit

Product Tracking & Reporting. All Rights Reserved  
Version: 26.3.2-864812dc

**From:** [Granillo, Lacey /C](#)  
**To:** [Clelland, Sarah, EMNRD](#)  
**Cc:** [Walker, Crystal L /C](#)  
**Subject:** [EXTERNAL] RE: Action ID 562358 PLC-1130  
**Date:** Tuesday, June 2, 2026 11:01:02 AM

**CAUTION:** This email originated outside of our organization. Exercise caution prior to clicking on links or opening attachments.

Good morning, Sarah-

I have sent the tracking numbers to the engineering email for OCD and copied you on it. I had to send it in two separate emails due to the size. Please let me know if you need anything further.

Thank you-  
Lacey

---

**From:** Walker, Crystal L /C <crystal.l.walker@exxonmobil.com>  
**Sent:** Monday, June 1, 2026 7:09 AM  
**To:** Granillo, Lacey /C <lacey.granillo@exxonmobil.com>  
**Cc:** Walker, Crystal L /C <crystal.l.walker@exxonmobil.com>  
**Subject:** FW: Action ID 562358 PLC-1130

Good morning Lacey,

Can you please contact the mail room for these tracking numbers?

Thank you,  
Crystal

---

**From:** Clelland, Sarah, EMNRD <[Sarah.Clelland@emnrn.dnm.gov](mailto:Sarah.Clelland@emnrn.dnm.gov)>  
**Sent:** Friday, May 29, 2026 4:47 PM  
**To:** Walker, Crystal L /C <[crystal.l.walker@exxonmobil.com](mailto:crystal.l.walker@exxonmobil.com)>  
**Subject:** Action ID 562358 PLC-1130

To whom it may concern (c/o Crystal Walker for XTO Energy, Inc),

The Division is reviewing the following application:

<b>Action ID</b>	<b>562358</b>
<b>Admin No.</b>	PLC-1130
<b>Applicant</b>	XTO Energy, Inc
<b>Title</b>	Nash Draw Unit 39H CTB
<b>Sub. Date</b>	03/12/2026

Please provide the following additional supplemental documents:



All tracking numbers for notice to interest owners are showing as invalid. Please provide proof of notification.

Please provide additional information regarding the following:

- 

Additional notes:

- 

All additional supplemental documents and information may be provided via email and should be done by replying to this email. The produced email chain will be uploaded to the file for this application.

Please note that failure to take steps to address each of the requests made in this email within 10 business days of receipt of this email may result in the Division rejecting the application requiring the submittal of a new application by the applicant once it is prepared to address each of the topics raised.

### **COMMENT**

Approval from Division is required prior to conducting work which modifies the well design.

Please contact the Environmental Bureau at [OCD.Enviro@emnrd.nm.gov](mailto:OCD.Enviro@emnrd.nm.gov) for instructions regarding the submittal process for applications of this type.

Thanks,

*Sarah Clelland*

**Petroleum Specialist**

State of New Mexico

Energy, Minerals, and Natural Resources Department

Oil Conservation Division

Cell: (505) 537-0627

[Sarah.Clelland@emnrd.nm.gov](mailto:Sarah.Clelland@emnrd.nm.gov)

**STATE OF NEW MEXICO  
ENERGY, MINERALS AND NATURAL RESOURCES DEPARTMENT  
OIL CONSERVATION DIVISION**

**APPLICATION FOR SURFACE COMMINGLING  
SUBMITTED BY XTO ENERGY, INC**

**ORDER NO. PLC-1130**

**ORDER**

The Director of the New Mexico Oil Conservation Division (“OCD”), having considered the application and the recommendation of the OCD Engineering Bureau, issues the following Order.

**FINDINGS OF FACT**

1. XTO Energy, Inc (“Applicant”) submitted a complete application to surface commingle the oil and gas production from the pools and leases described in Exhibit A (“Application”).
2. Applicant included a complete list of the wells currently dedicated to each pool and lease.
3. Applicant proposed a method to allocate the oil and gas production to the pools, leases, and wells to be commingled.
4. Applicant certified the commingling of oil and gas production from the pools, leases, and wells will not in reasonable probability reduce the value of the oil and gas production to less than if it had remained segregated.
5. Applicant in the notice for the Application stated that it sought authorization to prospectively include additional pools and leases in accordance with 19.15.12.10(C)(4)(g) NMAC.
6. Applicant stated that it sought authorization to surface commingle and off-lease measure, as applicable, oil and gas production from wells which have not yet been approved to be drilled, but will produce from a pool and lease as described in Exhibit A.
7. Applicant provided notice of the Application to all persons owning an interest in the oil and gas production to be commingled, including the owners of royalty and overriding royalty interests, regardless of whether they have a right or option to take their interests in kind, and those persons either submitted a written waiver or did not file an objection to the Application.
8. Applicant provided notice of the Application to the Bureau of Land Management (“BLM”) or New Mexico State Land Office (“NMSLO”), as applicable.

**CONCLUSIONS OF LAW**

9. OCD has jurisdiction to issue this Order pursuant to the Oil and Gas Act, NMSA 1978, §§ 70-2-6, 70-2-11, 70-2-12, 70-2-16, and 70-2-17, 19.15.12. NMAC, and 19.15.23. NMAC.

10. Applicant satisfied the notice requirements for the Application in accordance with 19.15.12.10(A)(2) NMAC, 19.15.12.10(C)(4)(c) NMAC, and 19.15.12.10(C)(4)(e) NMAC, as applicable.
11. Applicant satisfied the notice requirements for the Application in accordance with 19.15.23.9(A)(5) NMAC and 19.15.23.9(A)(6) NMAC, as applicable.
12. Applicant's proposed method of allocation, as modified herein, complies with 19.15.12.10(B)(1) NMAC or 19.15.12.10(C)(1) NMAC, as applicable.
13. Commingling of oil and gas production from state, federal, or tribal leases shall not commence until approved by the BLM or NMSLO, as applicable, in accordance with 19.15.12.10(B)(3) NMAC and 19.15.12.10(C)(4)(h) NMAC.
14. Applicant satisfied the notice requirements for the subsequent addition of pools, leases, and wells in the notice for the Application, in accordance with 19.15.12.10(C)(4)(g) NMAC. Subsequent additions of pools, leases, and wells within Applicant's defined parameters, as modified herein, will not, in reasonable probability, reduce the commingled production's value or otherwise adversely affect the interest owners in the production to be added.
15. By granting the Application with the conditions specified below, this Order prevents waste and protects correlative rights, public health, and the environment.

### **ORDER**

1. Applicant is authorized to surface commingle oil and gas production from the pools and leases as described in Exhibit A.

Applicant is authorized to surface commingle oil and gas production from the wells included in Exhibit A provided that they produce from a pool and lease described in Exhibit A.

Applicant is authorized to store and measure oil and gas production off-lease, as applicable, from the pools and leases as described in Exhibit A at a central tank battery or gas title transfer meter described in Exhibit A.

Applicant is authorized to surface commingle oil and gas production from wells not included in Exhibit A but that produce from a pool and lease as described in Exhibit A.

Applicant is authorized to store and measure oil and gas production off-lease, as applicable, from wells not included in Exhibit A but that produce from a pool and lease as described in Exhibit A at a central tank battery or gas title transfer meter described in Exhibit A.

2. The allocation of oil and gas production to wells not included in Exhibit A but that produce from a pool and lease as described in Exhibit A shall be determined in the same manner as to wells identified in Exhibit A that produce from that pool and lease, provided that if more than one allocation method is being used or if there are no wells identified in Exhibit A that produce from the pool and lease, then allocation of oil and gas production to each well not

included in Exhibit A shall be determined by OCD prior to commingling production from it with the production from another well.

3. The allocation of oil and gas production shall be based on the production life of each well as measured for three periods:

- a. The initial production period shall be measured from the first production until the earlier of either the peak production rate or thirty (30) days after the first production.

During the initial production period, the oil and gas production for each well identified in Exhibit A shall be allocated using a production curve calculated from a minimum of ten (10) well tests per month, except that any day in which a well test cannot achieve an accurate result due to a temporary change in oil and gas production shall not be included in the computation of time determining the well test schedule. The production curve shall be calculated by interpolating daily production for each day using the known daily production obtained by well tests and shall use a method of interpolation that is at minimum as accurate as maintaining a constant rate of change for each day's production between the known daily production values.

- b. The plateau period shall be measured from the end of the initial production period to the peak decline rate.

During the plateau period, the oil and gas production for each well identified in Exhibit A shall be allocated using a minimum of three (3) well tests per month.

- c. The decline period shall be measured from the end of the plateau period until the well is plugged and abandoned.

During the decline period, the oil and gas production for each well identified in Exhibit A shall be allocated as follows:

- i. a minimum of three (3) well tests per month when the decline rate is greater than twenty-two percent (22%) per month;
- ii. a minimum of two (2) well tests per month when the decline rate is between twenty-two percent (22%) and ten percent (10%) per month; and
- iii. a minimum of one (1) well test per month when the decline rate is less than ten percent (10%) per month.

Upon OCD's request, Applicant shall submit a Form C-103 to the OCD Engineering Bureau that contains the decline rate curve and other relevant information demonstrating the production life of a well.

Applicant shall conduct a well test by separating and metering the oil and gas production from that well for either:

- a. a minimum of twenty-four (24) consecutive hours; or

- b. a combination of nonconsecutive periods that meet the following conditions:
  - i. Each period shall be a minimum of six (6) hours.
  - ii. The total duration of the nonconsecutive periods shall be a minimum of eighteen (18) hours.
  - iii. A vessel shall be allowed to reach equilibrium and a sufficient liquid retention time for accurate measurement achieved prior to beginning the well test.

The well test requirements of this Order shall be suspended for any well shut-in for a period that continues for more than fifteen (15) days until the well commences production.

4. If Applicant recovers oil or gas production from produced water prior to Applicant injecting it or transferring custody of it, then that production shall be allocated to each well in the proportion that it contributed to the total produced water.
5. If Applicant recovers gas production using a vapor recovery unit (VRU), then that gas production shall be allocated to each well in the proportion that it contributed to the total oil production.
6. Applicant shall measure and market the commingled oil at a central tank battery described in Exhibit A in accordance with this Order and 19.15.18.15 NMAC or 19.15.23.8 NMAC.
7. Applicant shall measure and market the commingled gas at a well pad, central delivery point, central tank battery, or gas title transfer meter described in Exhibit A in accordance with this Order and 19.15.19.9 NMAC, provided however that if the gas is vented or flared, and regardless of the reason or authorization pursuant to 19.15.28.8(B) NMAC for such venting or flaring, Applicant shall measure or estimate the gas in accordance with 19.15.28.8(E) NMAC.
8. Applicant shall calibrate the meters used to measure or allocate oil and gas production in accordance with 19.15.12.10(C)(2) NMAC.
9. Applicant shall install and utilize vessels that are appropriately designed to ensure sufficient separation of the fluids and to accurately measure oil and gas production.
10. If the commingling of oil and gas production from any pool, lease, or well reduces the value of the commingled oil and gas production to less than if it had remained segregated, no later than sixty (60) days after the decrease in value has occurred Applicant shall submit a new surface commingling application to OCD to amend this Order to remove the pool, lease, or well whose oil and gas production caused the decrease in value. If Applicant fails to submit a new application, this Order shall terminate on the following day, and if OCD denies the application, this Order shall terminate on the date of such action.
11. Applicant may submit an application to amend this Order to add pools, leases, and subsequently drilled wells with spacing units adjacent to or within the tracts commingled by

this Order by submitting a Form C-107-B in accordance with 19.15.12.10(C)(4)(g) NMAC, provided the pools, leases, and subsequently drilled wells are within the identified parameters included in the Application.

12. If a well is not included in Exhibit A but produces from a pool and lease as described in Exhibit A, then Applicant shall submit Forms C-102 and C-103 to the OCD Engineering Bureau after the well has been approved to be drilled and prior to off-lease measuring or commingling oil or gas production from it with the production from another well. The Form C-103 shall reference this Order and identify the well, proposed method to determine the allocation of oil and gas production to it, and the location(s) that commingling of its production will occur.
13. Applicant shall not commence commingling oil or gas production from state, federal, or tribal leases until approved by the BLM or NMSLO, as applicable.
14. If OCD determines that Applicant has failed to comply with any provision of this Order, OCD may take any action authorized by the Oil and Gas Act or the New Mexico Administrative Code (NMAC).
15. OCD retains jurisdiction of this matter and reserves the right to modify or revoke this Order as it deems necessary.

**STATE OF NEW MEXICO  
OIL CONSERVATION DIVISION**



**ALBERT C. S. CHANG  
DIRECTOR**

**DATE: 06/05/2026**

State of New Mexico  
Energy, Minerals and Natural Resources Department

## Exhibit A

**Order: PLC-1130**  
**Operator: XTO Energy, Inc (5380)**  
**Central Tank Battery: Nash Draw Unit 39H Central Tank Battery**  
**Central Tank Battery Location: UL K, Section 12, Township 23 South, Range 29 East**  
**Gas Title Transfer Meter Location: UL K, Section 12, Township 23 South, Range 29 East**

### Pools

Pool Name	Pool Code
NASH DRAW;DELAWARE/BS (AVALON SAND)	47545
PURPLE SAGE;WOLFCAMP (GAS)	98220

### Leases as defined in 19.15.12.7(C) NMAC

Lease	UL or Q/Q	S-T-R
PA Delaware NMNM 105451826 (070992C)	ALL	01-23S-29E
	ALL	11-23S-29E
	ALL	12-23S-29E
	ALL	13-23S-29E
	ALL	14-23S-29E
	ALL	06-23S-30E
	ALL	07-23S-30E
	ALL	18-23S-30E
PA Wolfcamp NMNM 105670174 (070992D)	N2NE, S2NW, SW4	01-23S-29E
	NW4	12-23S-29E

### Wells

Well API	Well Name	UL or Q/Q	S-T-R	Pool
30-015-21781	NASH UNIT #003H	W2	01-23S-29E	98220
		NW4	12-23S-29E	
30-015-21800	NASH UNIT #005	NESE	13-23S-29E	47545
30-015-33991	NASH UNIT #034H	SESE	01-23S-29E	47545
30-015-30176	NASH UNIT #036H	NESE	11-23S-29E	47545
30-015-36951	NASH UNIT #039H	N2NE, SENE	11-23S-29E	47545
		SWNW	12-23S-29E	
30-015-37166	NASH UNIT #040H	W2SW	01-23S-29E	47545
		W2NW, SENW	12-23S-29E	
30-015-37165	NASH UNIT #041H	E2W2	01-23S-29E	47545
		E2NW	12-23S-29E	
30-015-42206	NASH UNIT #043H	NE4, N2SE, SWSE	01-23S-29E	47545
		W2NE	12-23S-29E	

Sante Fe Main Office  
Phone: (505) 476-3441

General Information  
Phone: (505) 629-6116

Online Phone Directory  
<https://www.emnrd.nm.gov/ocd/contact-us>

**State of New Mexico**  
**Energy, Minerals and Natural Resources**  
**Oil Conservation Division**  
**1220 S. St Francis Dr.**  
**Santa Fe, NM 87505**

CONDITIONS

Action 562358

**CONDITIONS**

Operator: XTO ENERGY, INC 3617 North Big Spring Street Midland, TX 79705	OGRID: 5380
	Action Number: 562358
	Action Type: [C-107] Surface Commingle or Off-Lease (C-107B)

**CONDITIONS**

Created By	Condition	Condition Date
sarah.clelland	Please review the content of the order to ensure you are familiar with the authorities granted and any conditions of approval. If you have any questions regarding this matter, please email us at <a href="mailto:OCD.Engineer@emnrd.nm.gov">OCD.Engineer@emnrd.nm.gov</a> .	6/9/2026