

District I - (575) 393-6161
1625 N. French Dr., Hobbs, NM 88240
District II - (575) 748-1283
811 S. First St., Artesia, NM 88210
District III - (505) 334-6178
1000 Rio Brazos Rd., Aztec, NM 87410
District IV - (505) 476-3460
1220 S. St. Francis Dr., Santa Fe, NM 87505

OIL CONSERVATION DIVISION
1220 South St. Francis Dr.
Santa Fe, NM 87505

WELL API NO. 30-015-34816
5. Indicate Type of Lease STATE <input type="checkbox"/> FEE <input type="checkbox"/>
6. State Oil & Gas Lease No. Federal
7. Lease Name or Unit Agreement Name Benson Delaware Unit
8. Well Number 008
9. OGRID Number 4378
10. Pool name or Wildcat Benson Delaware
11. Elevation (Show whether DR, RKB, RT, GR, etc.) 3423'

SUNDRY NOTICES AND REPORTS ON WELLS
(DO NOT USE THIS FORM FOR PROPOSALS TO DRILL OR TO DEEPEN OR PLUG BACK TO A DIFFERENT RESERVOIR. USE "APPLICATION FOR PERMIT" (FORM C-101) FOR SUCH PROPOSALS.)

1. Type of Well: Oil Well Gas Well Other: Injection

2. Name of Operator
Chi Operating Inc.

3. Address of Operator
P.O. Box 1799; Midland, TX 79702

4. Well Location
Unit Letter E : 2500 feet from the North line and 660 feet from the West line
Section 12 Township 19S Range 30E NMPM Eddy County

12. Check Appropriate Box to Indicate Nature of Notice, Report or Other Data

NOTICE OF INTENTION TO:

- PERFORM REMEDIAL WORK
- TEMPORARILY ABANDON
- PULL OR ALTER CASING
- DOWNHOLE COMMINGLE
- CLOSED-LOOP SYSTEM
- OTHER:
- PLUG AND ABANDON
- CHANGE PLANS
- MULTIPLE COMPL

SUBSEQUENT REPORT OF:

- REMEDIAL WORK
- COMMENCE DRILLING OPNS.
- CASING/CEMENT JOB
- ALTERING CASING
- P AND A
- OTHER:

13. Describe proposed or completed operations. (Clearly state all pertinent details, and give pertinent dates, including estimated date of starting any proposed work). SEE RULE 19.15.7.14 NMAC. For Multiple Completions: Attach wellbore diagram of proposed completion or recompletion.

Chi Energy Inc. respectfully submits this subsequent report of tubing repair. A successful MIT was performed per OCD procedures. The operations report, current wellbore diagram and MIT chart are attached.

Spud Date:

Rig Release Date:

I hereby certify that the information above is true and complete to the best of my knowledge and belief.

SIGNATURE: Susan B. Maunder TITLE Regulatory Consultant DATE 08/31/23

Type or print name Susan B. Maunder E-mail address: SMaunder@protonmail.com PHONE: 432-556-6501
For State Use Only

APPROVED BY: _____ TITLE _____ DATE _____
Conditions of Approval (if any): _____

**Benson Delaware Unit #008
API 30-015-34816
Operations Report**

Date	Operation Description
8/8/23	Move in and rig up pulling unit. ND wellhead, NU BOP. Unset packer, TOH with 147 joints 2-7/8 tubing. Shut in and shut down.
8/9/23	RU tubing testers, test in hole below slips to 5000#. Found 2 bad collars, replaced. Shut in and shut down.
8/10/23	RU pump truck, load annulus, problems with packer on/off tool. Unset backer and TOH, send packer in for rework and test. Shut in and shut down.
8/11/23	Load and test casing to 600 psi for 15 min, all good. TIH with rebuilt packer and 146 joints 2-7/8 IPC tubing and 2 2-7/8" x 8' IPC subs. Set packer at 4747' (top perf 4830'). Shut in and shut down.
8/14/23	"J" off of packer, load casing, circulate hole w/ 80 barrels 2% KCL water with corrosion inhibitor and oxygen dispersant. Latch back onto packer, test to 500#, all good.
8/15/23	RD pulling unit and wait for MIT and OCD/BLM witness approval.
8/23/23	MIT successfully performed per OCD procedures and Barbara Lydick.

CURRENT/PROPOSED WELLBORE SCHEMATIC	LEASE:	BENSON DELAWARE UNIT	WELL NO. 008
DATE: 8/29/2023	OPERATOR:	CHI OPERATING	API # 30-015-34816
	LOCATION:	2500' FNL, 660' FWL, 12-19S-30E	
	BHL:	1980' FNL, 660' FWL, 12-19S-30E	

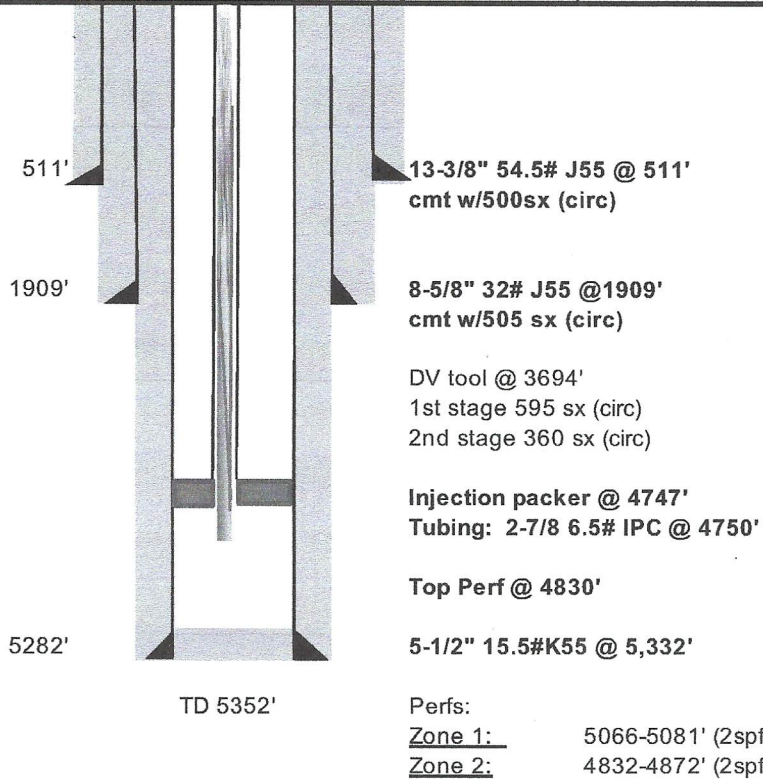

District I
 1625 N. French Dr., Hobbs, NM 88240
 Phone:(575) 393-6161 Fax:(575) 393-0720

District II
 811 S. First St., Artesia, NM 88210
 Phone:(575) 748-1283 Fax:(575) 748-9720

District III
 1000 Rio Brazos Rd., Aztec, NM 87410
 Phone:(505) 334-6178 Fax:(505) 334-6170

District IV
 1220 S. St Francis Dr., Santa Fe, NM 87505
 Phone:(505) 476-3470 Fax:(505) 476-3462

State of New Mexico
Energy, Minerals and Natural Resources
Oil Conservation Division
1220 S. St Francis Dr.
Santa Fe, NM 87505

COMMENTS

Action 260710

COMMENTS

Operator: CHI OPERATING INC P.O. Box 1799 Midland, TX 79702	OGRID: 4378
	Action Number: 260710
	Action Type: [C-103] Sub. Workover (C-103R)

COMMENTS

Created By	Comment	Comment Date
dmclure	Associated with Action ID: 239781	9/5/2023

District I
 1625 N. French Dr., Hobbs, NM 88240
 Phone:(575) 393-6161 Fax:(575) 393-0720

District II
 811 S. First St., Artesia, NM 88210
 Phone:(575) 748-1283 Fax:(575) 748-9720

District III
 1000 Rio Brazos Rd., Aztec, NM 87410
 Phone:(505) 334-6178 Fax:(505) 334-6170

District IV
 1220 S. St Francis Dr., Santa Fe, NM 87505
 Phone:(505) 476-3470 Fax:(505) 476-3462

State of New Mexico
Energy, Minerals and Natural Resources
Oil Conservation Division
1220 S. St Francis Dr.
Santa Fe, NM 87505

CONDITIONS

Action 260710

CONDITIONS

Operator: CHI OPERATING INC P.O. Box 1799 Midland, TX 79702	OGRID: 4378
	Action Number: 260710
	Action Type: [C-103] Sub. Workover (C-103R)

CONDITIONS

Created By	Condition	Condition Date
dmcclore	MITs shall be submitted separately as a C-103Z	9/5/2023