

Form 3160-5
(June 2019)

UNITED STATES
DEPARTMENT OF THE INTERIOR
BUREAU OF LAND MANAGEMENT

FORM APPROVED
OMB No. 1004-0137
Expires: October 31, 2021

SUNDRY NOTICES AND REPORTS ON WELLS
Do not use this form for proposals to drill or to re-enter an abandoned well. Use Form 3160-3 (APD) for such proposals.

SUBMIT IN TRIPLICATE - Other instructions on page 2		5. Lease Serial No.
1. Type of Well <input type="checkbox"/> Oil Well <input type="checkbox"/> Gas Well <input type="checkbox"/> Other		6. If Indian, Allottee or Tribe Name
2. Name of Operator		7. If Unit of CA/Agreement, Name and/or No.
3a. Address	3b. Phone No. (include area code)	8. Well Name and No.
4. Location of Well (Footage, Sec., T.,R.,M., or Survey Description)		9. API Well No.
		10. Field and Pool or Exploratory Area
		11. Country or Parish, State

12. CHECK THE APPROPRIATE BOX(ES) TO INDICATE NATURE OF NOTICE, REPORT OR OTHER DATA

TYPE OF SUBMISSION	TYPE OF ACTION			
<input type="checkbox"/> Notice of Intent	<input type="checkbox"/> Acidize	<input type="checkbox"/> Deepen	<input type="checkbox"/> Production (Start/Resume)	<input type="checkbox"/> Water Shut-Off
<input type="checkbox"/> Subsequent Report	<input type="checkbox"/> Alter Casing	<input type="checkbox"/> Hydraulic Fracturing	<input type="checkbox"/> Reclamation	<input type="checkbox"/> Well Integrity
<input type="checkbox"/> Final Abandonment Notice	<input type="checkbox"/> Casing Repair	<input type="checkbox"/> New Construction	<input type="checkbox"/> Recomplete	<input type="checkbox"/> Other
	<input type="checkbox"/> Change Plans	<input type="checkbox"/> Plug and Abandon	<input type="checkbox"/> Temporarily Abandon	
	<input type="checkbox"/> Convert to Injection	<input type="checkbox"/> Plug Back	<input type="checkbox"/> Water Disposal	

13. Describe Proposed or Completed Operation: Clearly state all pertinent details, including estimated starting date of any proposed work and approximate duration thereof. If the proposal is to deepen directionally or recomplete horizontally, give subsurface locations and measured and true vertical depths of all pertinent markers and zones. Attach the Bond under which the work will be performed or provide the Bond No. on file with BLM/BIA. Required subsequent reports must be filed within 30 days following completion of the involved operations. If the operation results in a multiple completion or recompletion in a new interval, a Form 3160-4 must be filed once testing has been completed. Final Abandonment Notices must be filed only after all requirements, including reclamation, have been completed and the operator has determined that the site is ready for final inspection.)

14. I hereby certify that the foregoing is true and correct. Name (Printed/Typed)	
	Title
Signature	Date

THE SPACE FOR FEDERAL OR STATE OFFICE USE

Approved by		
	Title	Date
Conditions of approval, if any, are attached. Approval of this notice does not warrant or certify that the applicant holds legal or equitable title to those rights in the subject lease which would entitle the applicant to conduct operations thereon.		
	Office	

Title 18 U.S.C Section 1001 and Title 43 U.S.C Section 1212, make it a crime for any person knowingly and willfully to make to any department or agency of the United States any false, fictitious or fraudulent statements or representations as to any matter within its jurisdiction.

(Instructions on page 2)

GENERAL INSTRUCTIONS

This form is designed for submitting proposals to perform certain well operations and reports of such operations when completed as indicated on Federal and Indian lands pursuant to applicable Federal law and regulations. Any necessary special instructions concerning the use of this form and the number of copies to be submitted, particularly with regard to local area or regional procedures and practices, are either shown below, will be issued by or may be obtained from the local Federal office.

SPECIFIC INSTRUCTIONS

Item 4 - Locations on Federal or Indian land should be described in accordance with Federal requirements. Consult the local Federal office for specific instructions.

Item 13: Proposals to abandon a well and subsequent reports of abandonment should include such special information as is required by the local Federal office. In addition, such proposals and reports should include reasons for the abandonment; data on any former or present productive zones or other zones with present significant fluid contents not sealed off by cement or otherwise; depths (top and bottom) and method of placement of cement plugs; mud or other material placed below, between and above plugs; amount, size, method of parting of any casing, liner or tubing pulled and the depth to the top of any tubing left in the hole; method of closing top of well and date well site conditioned for final inspection looking for approval of the abandonment. If the proposal will involve **hydraulic fracturing operations**, you must comply with 43 CFR 3162.3-3, including providing information about the protection of usable water. Operators should provide the best available information about all formations containing water and their depths. This information could include data and interpretation of resistivity logs run on nearby wells. Information may also be obtained from state or tribal regulatory agencies and from local BLM offices.

NOTICES

The privacy Act of 1974 and the regulation in 43 CFR 2.48(d) provide that you be furnished the following information in connection with information required by this application.

AUTHORITY: 30 U.S.C. 181 et seq., 351 et seq., 25 U.S.C. 396; 43 CFR 3160.

PRINCIPAL PURPOSE: The information is used to: (1) Evaluate, when appropriate, approve applications, and report completion of subsequent well operations, on a Federal or Indian lease; and (2) document for administrative use, information for the management, disposal and use of National Resource lands and resources, such as: (a) evaluating the equipment and procedures to be used during a proposed subsequent well operation and reviewing the completed well operations for compliance with the approved plan; (b) requesting and granting approval to perform those actions covered by 43 CFR 3162.3-2, 3162.3-3, and 3162.3-4; (c) reporting the beginning or resumption of production, as required by 43 CFR 3162.4-1(c) and (d) analyzing future applications to drill or modify operations in light of data obtained and methods used.

ROUTINE USES: Information from the record and/or the record will be transferred to appropriate Federal, State, local or foreign agencies, when relevant to civil, criminal or regulatory investigations or prosecutions in connection with congressional inquiries or to consumer reporting agencies to facilitate collection of debts owed the Government.

EFFECT OF NOT PROVIDING THE INFORMATION: Filing of this notice and report and disclosure of the information is mandatory for those subsequent well operations specified in 43 CFR 3162.3-2, 3162.3-3, 3162.3-4.

The Paperwork Reduction Act of 1995 requires us to inform you that:

The BLM collects this information to evaluate proposed and/or completed subsequent well operations on Federal or Indian oil and gas leases.

Response to this request is mandatory.

The BLM would like you to know that you do not have to respond to this or any other Federal agency-sponsored information collection unless it displays a currently valid OMB control number.

BURDEN HOURS STATEMENT: Public reporting burden for this form is estimated to average 8 hours per response, including the time for reviewing instructions, gathering and maintaining data, and completing and reviewing the form. Direct comments regarding the burden estimate or any other aspect of this form to U.S. Department of the Interior, Bureau of Land Management (1004-0137), Bureau Information Collection Clearance Officer (WO-630), 1849 C St., N.W., Mail Stop 401 LS, Washington, D.C. 20240

Additional Information

Location of Well

0. SHL: TR M / 1009 FSL / 1162 FWL / TWSP: 24S / RANGE: 32E / SECTION: 3 / LAT: 32.242096 / LONG: -103.6672851 (TVD: 0 feet, MD: 0 feet)

PPP: TR M / 100 FSL / 1254 FWL / TWSP: 24S / RANGE: 32E / SECTION: 3 / LAT: 32.2395995 / LONG: -103.6669875 (TVD: 9330 feet, MD: 9426 feet)

BHL: TR D / 100 FNL / 1870 FWL / TWSP: 23S / RANGE: 32E / SECTION: 34 / LAT: 32.2680669 / LONG: -103.6669958 (TVD: 9595 feet, MD: 19884 feet)

Form 3160-3
(August 2007)

FORM APPROVED
OMB No. 1004-0137
Expires July 31, 2010

UNITED STATES
DEPARTMENT OF THE INTERIOR
BUREAU OF LAND MANAGEMENT

APPLICATION FOR PERMIT TO DRILL OR REENTER

5. Lease Serial No. NMNM94850	
6. If Indian, Allottee or Tribe Name	
7. If Unit or CA Agreement, Name and No. NMNM144087	
8. Lease Name and Well No. PEGASUS 3 FED COM 324H	
9. API Well No.	
1a. Type of work: <input checked="" type="checkbox"/> DRILL <input type="checkbox"/> REENTER	10. Field and Pool, or Exploratory TRISTE DRAW;BONE SPRING
1b. Type of Well: <input checked="" type="checkbox"/> Oil Well <input type="checkbox"/> Gas Well <input type="checkbox"/> Other <input checked="" type="checkbox"/> Single Zone <input type="checkbox"/> Multiple Zone	11. Sec., T. R. M. or Blk. and Survey or Area SEC 3/T24S/R32E/NMP
2. Name of Operator EOG RESOURCES INCORPORATED	
3a. Address 1111 BAGBY SKY LOBBY 2, HOUSTON, TX 77002	3b. Phone No. (include area code) 713-651-7000
4. Location of Well (Report location clearly and in accordance with any State requirements.)* At surface TR M / 1009 FSL / 1117 FWL / LAT 32.2420956 / LONG -103.6674298 At proposed prod. zone TR C / 100 FNL / 1870 FWL / LAT 32.2680730 / LONG -103.6650028	
14. Distance in miles and direction from nearest town or post office*	
12. County or Parish LEA	
13. State NM	
15. Distance from proposed* 100 location to nearest property or lease line, ft. (Also to nearest drig. unit line, if any)	16. No. of acres in lease
17. Spacing Unit dedicated to this well 640	18. Distance from proposed location* 15 to nearest well, drilling, completed, applied for, on this lease, ft.
19. Proposed Depth 9580 FEET / 20258 FEET	20. BLM/BIA Bond No. on file FED: NM2308
21. Elevations (Show whether DF, KDB, RT, GL, etc.) 3655 FEET	22. Approximate date work will start* 07/29/2025
23. Estimated duration 25 DAYS	

24. Attachments

The following, completed in accordance with the requirements of Onshore Oil and Gas Order No.1, must be attached to this form:

- | | |
|--|---|
| 1. Well plat certified by a registered surveyor. | 4. Bond to cover the operations unless covered by an existing bond on file (see Item 20 above). |
| 2. A Drilling Plan. | 5. Operator certification |
| 3. A Surface Use Plan (if the location is on National Forest System Lands, the SUPO must be filed with the appropriate Forest Service Office). | 6. Such other site specific information and/or plans as may be required by the BLM. |

25. Signature <i>Kayla McConnell</i>	Name (Printed/Typed) KAYLA MCCONNELL	Date 07/28/2025
Title REGULATORY SPECIALIST		
Approved by (Signature)	Name (Printed/Typed)	Date 7/28/2025
Title Sup. PE	Office CFO	

Application approval does not warrant or certify that the applicant holds legal or equitable title to those rights in the subject lease which would entitle the applicant to conduct operations thereon.
Conditions of approval, if any, are attached.

Title 18 U.S.C. Section 1001 and Title 43 U.S.C. Section 1212, make it a crime for any person knowingly and willfully to make to any department or agency of the United States any false, fictitious or fraudulent statements or representations as to any matter within its jurisdiction.

(Continued on page 2)

*(Instructions on page 2)

INSTRUCTIONS

GENERAL: This form is designed for submitting proposals to perform certain well operations, as indicated on Federal and Indian lands and leases for action by appropriate Federal agencies, pursuant to applicable Federal laws and regulations. Any necessary special instructions concerning the use of this form and the number of copies to be submitted, particularly with regard to local, area, or regional procedures and practices, either are shown below or will be issued by, or may be obtained from local Federal offices.

ITEM 1: If the proposal is to redrill to the same reservoir at a different subsurface location or to a new reservoir, use this form with appropriate notations. Consult applicable Federal regulations concerning subsequent work proposals or reports on the well.

ITEM 4: Locations on Federal or Indian land should be described in accordance with Federal requirements. Consult local Federal offices for specific instructions.

ITEM 14: Needed only when location of well cannot readily be found by road from the land or lease description. A plat, or plats, separate or on the reverse side, showing the roads to, and the surveyed location of, the well, and any other required information, should be furnished when required by Federal agency offices.

ITEMS 15 AND 18: If well is to be, or has been directionally drilled, give distances for subsurface location of hole in any present or objective productive zone.

ITEM 22: Consult applicable Federal regulations, or appropriate officials, concerning approval of the proposal before operations are started.

NOTICES

The Privacy Act of 1974 and regulation in 43 CFR 2.48(d) provide that you be furnished the following information in connection with information required by this application.

AUTHORITY: 30 U.S.C. 181 et seq., 25 U.S.C. 396; 43 CFR 3160

PRINCIPAL PURPOSES: The information will be used to: (1) process and evaluate your application for a permit to drill a new oil, gas, or service well or to reenter a plugged and abandoned well; and (2) document, for administrative use, information for the management, disposal and use of National Resource Lands and resources including (a) analyzing your proposal to discover and extract the Federal or Indian resources encountered; (b) reviewing procedures and equipment and the projected impact on the land involved; and (c) evaluating the effects of the proposed operation on the surface and subsurface water and other environmental impacts.

ROUTINE USE: Information from the record and/or the record will be transferred to appropriate Federal, State, and local or foreign agencies, when relevant to civil, criminal or regulatory investigations or prosecution, in connection with congressional inquiries and for regulatory responsibilities.

EFFECT OF NOT PROVIDING INFORMATION: Filing of this application and disclosure of the information is mandatory only if you elect to initiate a drilling or reentry operation on an oil and gas lease.

The Paperwork Reduction Act of 1995 requires us to inform you that:

The BLM collects this information to allow evaluation of the technical, safety, and environmental factors involved with drilling for oil and/or gas on Federal and Indian oil and gas leases. This information will be used to analyze and approve applications.

Response to this request is mandatory only if the operator elects to initiate drilling or reentry operations on an oil and gas lease.

The BLM would like you to know that you do not have to respond to this or any other Federal agency-sponsored information collection unless it displays a currently valid OMB control number.

BURDEN HOURS STATEMENT: Public reporting burden for this form is estimated to average 8 hours per response, including the time for reviewing instructions, gathering and maintaining data, and completing and reviewing the form. Direct comments regarding the burden estimate or any other aspect of this form to U.S. Department of the Interior, Bureau of Land Management (1004-0137), Bureau Information Collection Clearance Officer (WO-630), 1849 C Street, N.W., Mail Stop 401 LS, Washington, D.C. 20240.

C-102 Submit Electronically Via OCD Permitting	State of New Mexico Energy, Minerals & Natural Resources Department OIL CONSERVATION DIVISION	Revised July 9, 2024 Submittal Type: <input type="checkbox"/> Initial Submittal <input checked="" type="checkbox"/> Amended Report <input type="checkbox"/> As Drilled
---	--	--

WELL LOCATION AND ACREAGE DEDICATION PLAT

API Number 30-025-	Pool Code 96603	Pool Name TRISTE DRAW; BONE SPRING
Property Code 328120	Property Name PEGASUS 3 FED COM	Well Number 324H
OGRID No. 7377	Operator Name EOG RESOURCES, INC.	Ground Level Elevation 3655'
Surface Owner: <input type="checkbox"/> State <input type="checkbox"/> Fee <input type="checkbox"/> Tribal <input checked="" type="checkbox"/> Federal		Mineral Owner: <input type="checkbox"/> State <input type="checkbox"/> Fee <input type="checkbox"/> Tribal <input checked="" type="checkbox"/> Federal

Surface Location

UL or lot no.	Section	Township	Range	Lot Idn	Feet from the N/S	Feet from the E/W	Latitude	Longitude	County
M	3	24-S	32-E	-	1009' S	1117' W	N 32.2420956	W 103.6674298	LEA

Bottom Hole Location

UL or lot no.	Section	Township	Range	Lot Idn	Feet from the N/S	Feet from the E/W	Latitude	Longitude	County
C	34	23-S	32-E	-	100' N	1870' W	N 32.2680730	W 103.6650028	LEA

Dedicated Acres 639.61	Infill or Defining Well INFILL	Defining Well API 30-025-47250	Overlapping Spacing Unit (Y/N) N	Consolidated Code C
Order Numbers NMNM 144087			Well Setbacks are under Common Ownership: <input type="checkbox"/> Yes <input type="checkbox"/> No	

Kick Off Point (KOP)

UL or lot no.	Section	Township	Range	Lot Idn	Feet from the N/S	Feet from the E/W	Latitude	Longitude	County
N	3	24-S	32-E	-	50' S	1870' W	N 32.2394709	W 103.6649951	LEA

First Take Point (FTP)

UL or lot no.	Section	Township	Range	Lot Idn	Feet from the N/S	Feet from the E/W	Latitude	Longitude	County
N	3	24-S	32-E	-	100' S	1870' W	N 32.2396083	W 103.6649951	LEA

Last Take Point (LTP)

UL or lot no.	Section	Township	Range	Lot Idn	Feet from the N/S	Feet from the E/W	Latitude	Longitude	County
C	34	23-S	32-E	-	100' N	1870' W	N 32.2680730	W 103.6650028	LEA

Unitized Area or Area of Uniform Interest COMM AGREEMENT	Spacing Unity Type <input checked="" type="checkbox"/> Horizontal <input type="checkbox"/> Vertical	Ground Floor Elevation 3680'
--	--	--

<h4>OPERATOR CERTIFICATION</h4> <p><i>I hereby certify that the information contained herein is true and complete to the best of my knowledge and belief; and, if the well is a vertical or directional well, that this organization either owns a working interest or unleased mineral interest in the land including the proposed bottom hole location or has a right to drill this well at this location pursuant to a contract with an owner of a working interest or unleased mineral interest, or to a voluntary pooling agreement or a compulsory pooling order heretofore entered by the division.</i></p> <p><i>If this well is a horizontal well, I further certify that this organization has received The consent of at least one lessee or owner of a working interest or unleased mineral interest in each tract (in the target pool or formation) in which any part of the well's completed interval will be located or obtained a compulsory pooling order from the division.</i></p> <p style="font-size: 1.2em; font-family: cursive;">Kayla McConnell</p> <p style="text-align: right;">07/28/2025</p>	<h4>SURVEYORS CERTIFICATION</h4> <p><i>I hereby certify that the well location shown on this plat was plotted from field notes of actual surveys made by me or under my supervision, and that the same is true and correct to the best of my belief.</i></p> <div style="text-align: center;"> <p>7/25/2025 2:55:06 PM</p> </div>
Signature Date KAYLA MCCONNELL	Signature and Seal of Professional Surveyor Date
Print Name KAYLA_MCCONNELL@EOGRESOURCES.COM	Certificate Number Date of Survey 04/30/2025
E-mail Address	

<p>C-102</p> <p>Submit Electronically Via OCD Permitting</p>	<p>State of New Mexico Energy, Minerals & Natural Resources Department OIL CONSERVATION DIVISION</p>	<p>Revised July 9, 2024</p>
		<p>Submittal Type:</p> <p><input type="checkbox"/> Initial Submittal</p> <p><input checked="" type="checkbox"/> Amended Report</p> <p><input type="checkbox"/> As Drilled</p>
<p>Property Name and Well Number</p> <p style="text-align: center;">PEGASUS 3 FED COM 324H</p>		

<p>SURFACE LOCATION (SHL)</p> <p>NEW MEXICO EAST NAD 1983 X=747217 Y=452446 LAT.: N 32.2420956 LONG.: W 103.6674298</p> <p style="color: red;">NAD 1927 X=706034 Y=452387 LAT.: N 32.2419724 LONG.: W 103.6669483</p> <p>1009' FSL 1117' FWL</p> <p>KICK OFF POINT (KOP)</p> <p>NEW MEXICO EAST NAD 1983 X=747976 Y=451496 LAT.: N 32.2394709 LONG.: W 103.6649951</p> <p style="color: red;">NAD 1927 X=706792 Y=451437 LAT.: N 32.2393476 LONG.: W 103.6645139</p> <p>50' FSL 1870' FWL</p> <p>UPPER MOST PERF. (UMP)</p> <p>NEW MEXICO EAST NAD 1983 X=747976 Y=451546 LAT.: N 32.2396083 LONG.: W 103.6649951</p> <p style="color: red;">NAD 1927 X=706792 Y=451487 LAT.: N 32.2394851 LONG.: W 103.6645139</p> <p>100' FSL 1870' FWL</p> <p>PROPOSED PERF. POINT (PPP1)</p> <p>NEW MEXICO EAST NAD 1983 X=747968 Y=452766 LAT.: N 32.2429609 LONG.: W 103.6649961</p> <p style="color: red;">NAD 1927 X=706784 Y=452707 LAT.: N 32.2428378 LONG.: W 103.6645146</p> <p>1320' FSL 1869' FWL</p>		<p>PROPOSED PERF. POINT (PPP2)</p> <p>NEW MEXICO EAST NAD 1983 X=747959 Y=454085 LAT.: N 32.2465885 LONG.: W 103.6649970</p> <p style="color: red;">NAD 1927 X=706776 Y=454026 LAT.: N 32.2464653 LONG.: W 103.6645155</p> <p>2629' FNL 1869' FWL</p> <p>PROPOSED PERF. POINT (PPP3)</p> <p>NEW MEXICO EAST NAD 1983 X=747942 Y=456714 LAT.: N 32.2538130 LONG.: W 103.6649990</p> <p style="color: red;">NAD 1927 X=706759 Y=456655 LAT.: N 32.2536899 LONG.: W 103.6645171</p> <p>0' FNL 1871' FWL</p> <p>LOWER MOST PERF. (LMP) BOTTOM HOLE LOCATION (BHL)</p> <p>NEW MEXICO EAST NAD 1983 X=747909 Y=461901 LAT.: N 32.2680730 LONG.: W 103.6650028</p> <p style="color: red;">NAD 1927 X=706725 Y=461842 LAT.: N 32.2679501 LONG.: W 103.6645203</p> <p>100' FNL 1870' FWL</p>
<div style="border: 1px solid black; padding: 5px; width: fit-content;"> <p>T-24-S, R-32-E SECTION 3 LOT 1 - 39.67 ACRES LOT 2 - 39.72 ACRES LOT 3 - 39.78 ACRES LOT 4 - 39.83 ACRES</p> </div>	<p>SURVEYORS CERTIFICATION</p> <p><i>I hereby certify that the well location shown on this plat was plotted from field notes of actual surveys made by me or under my supervision, and that the same is true and correct to the best of my belief.</i></p> <p>04/30/2025</p> <p>Date of Survey Signature and Seal of Professional Surveyor:</p>	

EXHIBIT 2B



LEGEND

SECTION LINE

SECTION 3, TOWNSHIP 24-S, RANGE 32-E, N.M.P.M.
LEA COUNTY, NEW MEXICO

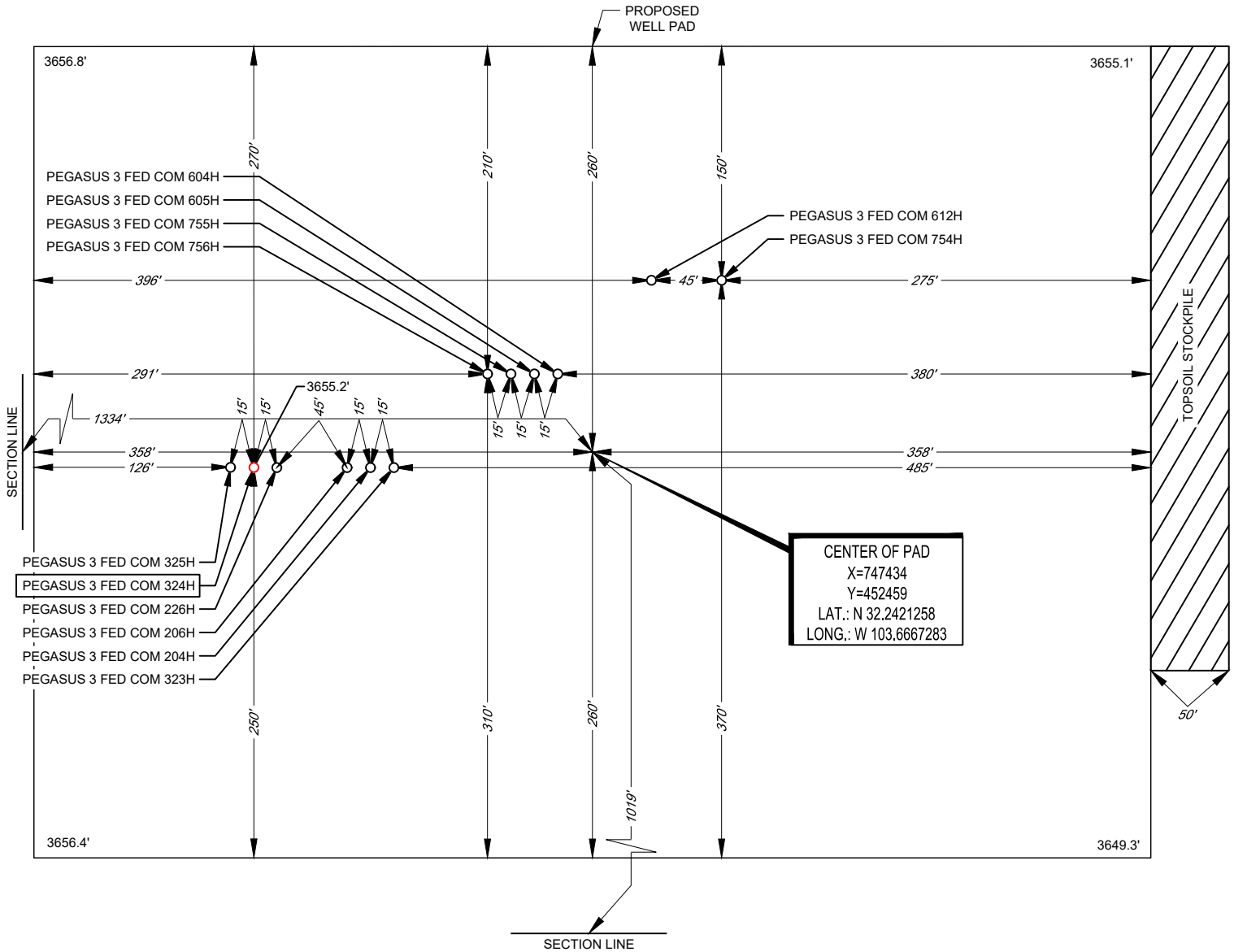

7/25/2025 2:55:09 PM

Ramon A. Dominguez, P.S. No. 24508

LEASE NAME & WELL NO.: PEGASUS 3 FED COM 324H
 324H LATITUDE N 32.2420956 324H LONGITUDE W 103.6674298

CENTER OF PAD IS 1019' FSL & 1334' FWL

ALL BEARINGS, DISTANCES, AND COORDINATE VALUES CONTAINED HEREON ARE GRID BASED UPON THE NEW MEXICO COORDINATE SYSTEM OF 1983, EAST ZONE, U.S. SURVEY FEET. ELEVATIONS USED ARE NAVD88, OBTAINED THROUGH AN OPUS SOLUTION.

THIS PROPOSED PAD SITE LOCATION SHOWN HEREON HAS BEEN SURVEYED ON THE GROUND UNDER MY SUPERVISION AND PREPARED ACCORDING TO THE EVIDENCE FOUND AT THE TIME OF SURVEY, AND DATA PROVIDED BY EOG RESOURCES, INC. ONLY THE DATA SHOWN ABOVE IS BEING CERTIFIED TO. ALL OTHER INFORMATION WAS INTENTIONALLY OMITTED. THIS PLAT IS ONLY INTENDED TO BE USED FOR A PERMIT AND IS NOT A BOUNDARY SURVEY. THIS CERTIFICATION IS MADE AND LIMITED TO THOSE PERSONS OR ENTITIES SHOWN ON THE FACE OF THIS PLAT AND IS NON-TRANSFERABLE. THIS SURVEY IS CERTIFIED FOR THIS TRANSACTION ONLY.

ORIGINAL DOCUMENT SIZE: 8.5" X 11"

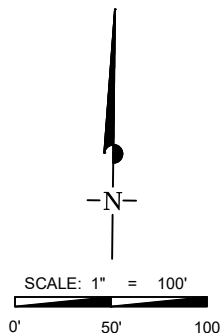

481 WINSOTT ROAD, Ste. 200 • BENBROOK, TEXAS 76126
 TELEPHONE: (817) 744-7512 • FAX (817) 744-7554
 2903 NORTH BIG SPRING • MIDLAND, TEXAS 79705
 TELEPHONE: (432) 682-1653 OR (800) 767-1653 • FAX (432) 682-1743
 WWW.TOPOGRAPHIC.COM

Form 3160-3
(August 2007)

FORM APPROVED
OMB No. 1004-0137
Expires July 31, 2010

UNITED STATES
DEPARTMENT OF THE INTERIOR
BUREAU OF LAND MANAGEMENT

APPLICATION FOR PERMIT TO DRILL OR REENTER

5. Lease Serial No. NMNM94850	
6. If Indian, Allottee or Tribe Name	
7. If Unit or CA Agreement, Name and No. NMNM144087	
8. Lease Name and Well No. PEGASUS 3 FED COM 324H	
9. API Well No.	
1a. Type of work: <input checked="" type="checkbox"/> DRILL <input type="checkbox"/> REENTER	10. Field and Pool, or Exploratory TRISTE DRAW;BONE SPRING
1b. Type of Well: <input checked="" type="checkbox"/> Oil Well <input type="checkbox"/> Gas Well <input type="checkbox"/> Other <input checked="" type="checkbox"/> Single Zone <input type="checkbox"/> Multiple Zone	11. Sec., T. R. M. or Blk. and Survey or Area SEC 3/T24S/R32E/NMP
2. Name of Operator EOG RESOURCES INCORPORATED	
3a. Address 1111 BAGBY SKY LOBBY 2, HOUSTON, TX 77002	3b. Phone No. (include area code) 713-651-7000
4. Location of Well (Report location clearly and in accordance with any State requirements.)* At surface TR M / 1009 FSL / 1117 FWL / LAT 32.2420956 / LONG -103.6674298 At proposed prod. zone TR C / 100 FNL / 1870 FWL / LAT 32.2680730 / LONG -103.6650028	
14. Distance in miles and direction from nearest town or post office*	
12. County or Parish LEA	
13. State NM	
15. Distance from proposed* 100 location to nearest property or lease line, ft. (Also to nearest drig. unit line, if any)	16. No. of acres in lease
17. Spacing Unit dedicated to this well 640	18. Distance from proposed location* 15 to nearest well, drilling, completed, applied for, on this lease, ft.
19. Proposed Depth 9580 FEET / 20258 FEET	20. BLM/BIA Bond No. on file FED: NM2308
21. Elevations (Show whether DF, KDB, RT, GL, etc.) 3655 FEET	22. Approximate date work will start* 07/29/2025
23. Estimated duration 25 DAYS	

24. Attachments

The following, completed in accordance with the requirements of Onshore Oil and Gas Order No.1, must be attached to this form:

- | | |
|--|---|
| 1. Well plat certified by a registered surveyor. | 4. Bond to cover the operations unless covered by an existing bond on file (see Item 20 above). |
| 2. A Drilling Plan. | 5. Operator certification |
| 3. A Surface Use Plan (if the location is on National Forest System Lands, the SUPO must be filed with the appropriate Forest Service Office). | 6. Such other site specific information and/or plans as may be required by the BLM. |

25. Signature <i>Kayla McConnell</i>	Name (Printed/Typed) KAYLA MCCONNELL	Date 07/28/2025
Title REGULATORY SPECIALIST		
Approved by (Signature)	Name (Printed/Typed)	Date
Title	Office	

Application approval does not warrant or certify that the applicant holds legal or equitable title to those rights in the subject lease which would entitle the applicant to conduct operations thereon.
Conditions of approval, if any, are attached.

Title 18 U.S.C. Section 1001 and Title 43 U.S.C. Section 1212, make it a crime for any person knowingly and willfully to make to any department or agency of the United States any false, fictitious or fraudulent statements or representations as to any matter within its jurisdiction.

(Continued on page 2)

*(Instructions on page 2)

INSTRUCTIONS

GENERAL: This form is designed for submitting proposals to perform certain well operations, as indicated on Federal and Indian lands and leases for action by appropriate Federal agencies, pursuant to applicable Federal laws and regulations. Any necessary special instructions concerning the use of this form and the number of copies to be submitted, particularly with regard to local, area, or regional procedures and practices, either are shown below or will be issued by, or may be obtained from local Federal offices.

ITEM 1: If the proposal is to redrill to the same reservoir at a different subsurface location or to a new reservoir, use this form with appropriate notations. Consult applicable Federal regulations concerning subsequent work proposals or reports on the well.

ITEM 4: Locations on Federal or Indian land should be described in accordance with Federal requirements. Consult local Federal offices for specific instructions.

ITEM 14: Needed only when location of well cannot readily be found by road from the land or lease description. A plat, or plats, separate or on the reverse side, showing the roads to, and the surveyed location of, the well, and any other required information, should be furnished when required by Federal agency offices.

ITEMS 15 AND 18: If well is to be, or has been directionally drilled, give distances for subsurface location of hole in any present or objective productive zone.

ITEM 22: Consult applicable Federal regulations, or appropriate officials, concerning approval of the proposal before operations are started.

NOTICES

The Privacy Act of 1974 and regulation in 43 CFR 2.48(d) provide that you be furnished the following information in connection with information required by this application.

AUTHORITY: 30 U.S.C. 181 et seq., 25 U.S.C. 396; 43 CFR 3160

PRINCIPAL PURPOSES: The information will be used to: (1) process and evaluate your application for a permit to drill a new oil, gas, or service well or to reenter a plugged and abandoned well; and (2) document, for administrative use, information for the management, disposal and use of National Resource Lands and resources including (a) analyzing your proposal to discover and extract the Federal or Indian resources encountered; (b) reviewing procedures and equipment and the projected impact on the land involved; and (c) evaluating the effects of the proposed operation on the surface and subsurface water and other environmental impacts.

ROUTINE USE: Information from the record and/or the record will be transferred to appropriate Federal, State, and local or foreign agencies, when relevant to civil, criminal or regulatory investigations or prosecution, in connection with congressional inquiries and for regulatory responsibilities.

EFFECT OF NOT PROVIDING INFORMATION: Filing of this application and disclosure of the information is mandatory only if you elect to initiate a drilling or reentry operation on an oil and gas lease.

The Paperwork Reduction Act of 1995 requires us to inform you that:

The BLM collects this information to allow evaluation of the technical, safety, and environmental factors involved with drilling for oil and/or gas on Federal and Indian oil and gas leases. This information will be used to analyze and approve applications.

Response to this request is mandatory only if the operator elects to initiate drilling or reentry operations on an oil and gas lease.

The BLM would like you to know that you do not have to respond to this or any other Federal agency-sponsored information collection unless it displays a currently valid OMB control number.

BURDEN HOURS STATEMENT: Public reporting burden for this form is estimated to average 8 hours per response, including the time for reviewing instructions, gathering and maintaining data, and completing and reviewing the form. Direct comments regarding the burden estimate or any other aspect of this form to U.S. Department of the Interior, Bureau of Land Management (1004-0137), Bureau Information Collection Clearance Officer (WO-630), 1849 C Street, N.W., Mail Stop 401 LS, Washington, D.C. 20240.



Midland

Lea County, NM (NAD 83 NME)

Pegasus 3 Fed Com

#324H

OH

Plan: Plan #0.1

Standard Planning Report

28 July, 2025



Planning Report

Database:	PEDMB	Local Co-ordinate Reference:	Well #324H
Company:	Midland	TVD Reference:	KB = 32' @ 3687.0usft
Project:	Lea County, NM (NAD 83 NME)	MD Reference:	KB = 32' @ 3687.0usft
Site:	Pegasus 3 Fed Com	North Reference:	Grid
Well:	#324H	Survey Calculation Method:	Minimum Curvature
Wellbore:	OH		
Design:	Plan #0.1		

Project	Lea County, NM (NAD 83 NME)		
Map System:	US State Plane 1983	System Datum:	Mean Sea Level
Geo Datum:	North American Datum 1983		
Map Zone:	New Mexico Eastern Zone		

Site	Pegasus 3 Fed Com				
Site Position:		Northing:	451,857.00 usft	Latitude:	32° 14' 25.685 N
From:	Map	Easting:	747,693.00 usft	Longitude:	103° 39' 57.253 W
Position Uncertainty:	0.0 usft	Slot Radius:	13-3/16 "		

Well	#324H					
Well Position	+N/-S	0.0 usft	Northing:	452,446.00 usft	Latitude:	32° 14' 31.543 N
	+E/-W	0.0 usft	Easting:	747,217.00 usft	Longitude:	103° 40' 2.752 W
Position Uncertainty	0.0 usft		Wellhead Elevation:	usft	Ground Level:	3,655.0 usft
Grid Convergence:	0.36 °					

Wellbore	OH				
Magnetics	Model Name	Sample Date	Declination (°)	Dip Angle (°)	Field Strength (nT)
	IGRF2025	7/28/2025	6.29	59.76	47,010.21111210

Design	Plan #0.1			
Audit Notes:				
Version:	Phase:	PLAN	Tie On Depth:	0.0
Vertical Section:	Depth From (TVD) (usft)	+N/-S (usft)	+E/-W (usft)	Direction (°)
	0.0	0.0	0.0	359.63

Plan Survey Tool Program	Date	7/28/2025		
Depth From (usft)	Depth To (usft)	Survey (Wellbore)	Tool Name	Remarks
1	0.0	20,257.6 Plan #0.1 (OH)	EOG MWD+IFR1 MWD + IFR1	



Planning Report

Database:	PEDMB	Local Co-ordinate Reference:	Well #324H
Company:	Midland	TVD Reference:	KB = 32' @ 3687.0usft
Project:	Lea County, NM (NAD 83 NME)	MD Reference:	KB = 32' @ 3687.0usft
Site:	Pegasus 3 Fed Com	North Reference:	Grid
Well:	#324H	Survey Calculation Method:	Minimum Curvature
Wellbore:	OH		
Design:	Plan #0.1		

Plan Sections										
Measured Depth (usft)	Inclination (°)	Azimuth (°)	Vertical Depth (usft)	+N/-S (usft)	+E/-W (usft)	Dogleg Rate (°/100usft)	Build Rate (°/100usft)	Turn Rate (°/100usft)	TFO (°)	Target
0.0	0.00	0.00	0.0	0.0	0.0	0.00	0.00	0.00	0.00	
1,400.0	0.00	0.00	1,400.0	0.0	0.0	0.00	0.00	0.00	0.00	
2,079.0	13.58	141.38	2,072.7	-62.6	50.0	2.00	2.00	0.00	141.38	
6,575.4	13.58	141.38	6,443.3	-887.4	709.0	0.00	0.00	0.00	0.00	
7,254.4	0.00	0.00	7,116.0	-950.0	759.0	2.00	-2.00	0.00	180.00	
9,579.9	0.00	0.00	9,441.5	-950.0	759.0	0.00	0.00	0.00	0.00	KOP(Pegasus 3 Fed C
9,800.3	26.46	0.00	9,654.2	-900.0	759.0	12.00	12.00	0.00	0.00	FTP(Pegasus 3 Fed C
10,329.8	90.00	359.58	9,918.9	-472.6	756.8	12.00	12.00	-0.08	-0.47	
11,122.4	90.00	359.58	9,919.0	320.0	751.0	0.00	0.00	0.00	0.00	Fed Perf #1(Pegasus
12,441.5	90.00	359.64	9,919.0	1,639.0	742.0	0.00	0.00	0.00	82.60	Fed Perf #2(Pegasus
15,070.5	90.00	359.62	9,919.0	4,268.0	725.0	0.00	0.00	0.00	-111.87	Fed Perf #3(Pegasus
20,257.6	90.00	359.65	9,919.0	9,455.0	692.0	0.00	0.00	0.00	76.01	PBHL(Pegasus 3 Fed



Planning Report

Database:	PEDMB	Local Co-ordinate Reference:	Well #324H
Company:	Midland	TVD Reference:	KB = 32' @ 3687.0usft
Project:	Lea County, NM (NAD 83 NME)	MD Reference:	KB = 32' @ 3687.0usft
Site:	Pegasus 3 Fed Com	North Reference:	Grid
Well:	#324H	Survey Calculation Method:	Minimum Curvature
Wellbore:	OH		
Design:	Plan #0.1		

Planned Survey									
Measured Depth (usft)	Inclination (°)	Azimuth (°)	Vertical Depth (usft)	+N/-S (usft)	+E/-W (usft)	Vertical Section (usft)	Dogleg Rate (°/100usft)	Build Rate (°/100usft)	Turn Rate (°/100usft)
0.0	0.00	0.00	0.0	0.0	0.0	0.0	0.00	0.00	0.00
100.0	0.00	0.00	100.0	0.0	0.0	0.0	0.00	0.00	0.00
200.0	0.00	0.00	200.0	0.0	0.0	0.0	0.00	0.00	0.00
300.0	0.00	0.00	300.0	0.0	0.0	0.0	0.00	0.00	0.00
400.0	0.00	0.00	400.0	0.0	0.0	0.0	0.00	0.00	0.00
500.0	0.00	0.00	500.0	0.0	0.0	0.0	0.00	0.00	0.00
600.0	0.00	0.00	600.0	0.0	0.0	0.0	0.00	0.00	0.00
700.0	0.00	0.00	700.0	0.0	0.0	0.0	0.00	0.00	0.00
800.0	0.00	0.00	800.0	0.0	0.0	0.0	0.00	0.00	0.00
900.0	0.00	0.00	900.0	0.0	0.0	0.0	0.00	0.00	0.00
1,000.0	0.00	0.00	1,000.0	0.0	0.0	0.0	0.00	0.00	0.00
1,100.0	0.00	0.00	1,100.0	0.0	0.0	0.0	0.00	0.00	0.00
1,200.0	0.00	0.00	1,200.0	0.0	0.0	0.0	0.00	0.00	0.00
1,300.0	0.00	0.00	1,300.0	0.0	0.0	0.0	0.00	0.00	0.00
1,400.0	0.00	0.00	1,400.0	0.0	0.0	0.0	0.00	0.00	0.00
1,500.0	2.00	141.38	1,500.0	-1.4	1.1	-1.4	2.00	2.00	0.00
1,600.0	4.00	141.38	1,599.8	-5.5	4.4	-5.5	2.00	2.00	0.00
1,700.0	6.00	141.38	1,699.5	-12.3	9.8	-12.3	2.00	2.00	0.00
1,800.0	8.00	141.38	1,798.7	-21.8	17.4	-21.9	2.00	2.00	0.00
1,900.0	10.00	141.38	1,897.5	-34.0	27.2	-34.2	2.00	2.00	0.00
2,000.0	12.00	141.38	1,995.6	-48.9	39.1	-49.2	2.00	2.00	0.00
2,079.0	13.58	141.38	2,072.7	-62.6	50.0	-62.9	2.00	2.00	0.00
2,100.0	13.58	141.38	2,093.1	-66.4	53.1	-66.8	0.00	0.00	0.00
2,200.0	13.58	141.38	2,190.3	-84.8	67.7	-85.2	0.00	0.00	0.00
2,300.0	13.58	141.38	2,287.5	-103.1	82.4	-103.6	0.00	0.00	0.00
2,400.0	13.58	141.38	2,384.7	-121.5	97.0	-122.1	0.00	0.00	0.00
2,500.0	13.58	141.38	2,481.9	-139.8	111.7	-140.5	0.00	0.00	0.00
2,600.0	13.58	141.38	2,579.1	-158.1	126.4	-159.0	0.00	0.00	0.00
2,700.0	13.58	141.38	2,676.3	-176.5	141.0	-177.4	0.00	0.00	0.00
2,800.0	13.58	141.38	2,773.5	-194.8	155.7	-195.8	0.00	0.00	0.00
2,900.0	13.58	141.38	2,870.7	-213.2	170.3	-214.3	0.00	0.00	0.00
3,000.0	13.58	141.38	2,967.9	-231.5	185.0	-232.7	0.00	0.00	0.00
3,100.0	13.58	141.38	3,065.1	-249.9	199.6	-251.2	0.00	0.00	0.00
3,200.0	13.58	141.38	3,162.3	-268.2	214.3	-269.6	0.00	0.00	0.00
3,300.0	13.58	141.38	3,259.5	-286.6	228.9	-288.0	0.00	0.00	0.00
3,400.0	13.58	141.38	3,356.7	-304.9	243.6	-306.5	0.00	0.00	0.00
3,500.0	13.58	141.38	3,453.9	-323.3	258.3	-324.9	0.00	0.00	0.00
3,600.0	13.58	141.38	3,551.1	-341.6	272.9	-343.4	0.00	0.00	0.00
3,700.0	13.58	141.38	3,648.3	-359.9	287.6	-361.8	0.00	0.00	0.00
3,800.0	13.58	141.38	3,745.5	-378.3	302.2	-380.2	0.00	0.00	0.00
3,900.0	13.58	141.38	3,842.7	-396.6	316.9	-398.7	0.00	0.00	0.00
4,000.0	13.58	141.38	3,940.0	-415.0	331.5	-417.1	0.00	0.00	0.00
4,100.0	13.58	141.38	4,037.2	-433.3	346.2	-435.5	0.00	0.00	0.00
4,200.0	13.58	141.38	4,134.4	-451.7	360.9	-454.0	0.00	0.00	0.00
4,300.0	13.58	141.38	4,231.6	-470.0	375.5	-472.4	0.00	0.00	0.00
4,400.0	13.58	141.38	4,328.8	-488.4	390.2	-490.9	0.00	0.00	0.00
4,500.0	13.58	141.38	4,426.0	-506.7	404.8	-509.3	0.00	0.00	0.00
4,600.0	13.58	141.38	4,523.2	-525.0	419.5	-527.7	0.00	0.00	0.00
4,700.0	13.58	141.38	4,620.4	-543.4	434.1	-546.2	0.00	0.00	0.00
4,800.0	13.58	141.38	4,717.6	-561.7	448.8	-564.6	0.00	0.00	0.00
4,900.0	13.58	141.38	4,814.8	-580.1	463.5	-583.1	0.00	0.00	0.00
5,000.0	13.58	141.38	4,912.0	-598.4	478.1	-601.5	0.00	0.00	0.00
5,100.0	13.58	141.38	5,009.2	-616.8	492.8	-619.9	0.00	0.00	0.00
5,200.0	13.58	141.38	5,106.4	-635.1	507.4	-638.4	0.00	0.00	0.00



Planning Report

Database:	PEDMB	Local Co-ordinate Reference:	Well #324H
Company:	Midland	TVD Reference:	KB = 32' @ 3687.0usft
Project:	Lea County, NM (NAD 83 NME)	MD Reference:	KB = 32' @ 3687.0usft
Site:	Pegasus 3 Fed Com	North Reference:	Grid
Well:	#324H	Survey Calculation Method:	Minimum Curvature
Wellbore:	OH		
Design:	Plan #0.1		

Planned Survey										
Measured Depth (usft)	Inclination (°)	Azimuth (°)	Vertical Depth (usft)	+N/-S (usft)	+E/-W (usft)	Vertical Section (usft)	Dogleg Rate (°/100usft)	Build Rate (°/100usft)	Turn Rate (°/100usft)	
5,300.0	13.58	141.38	5,203.6	-653.5	522.1	-656.8	0.00	0.00	0.00	
5,400.0	13.58	141.38	5,300.8	-671.8	536.7	-675.3	0.00	0.00	0.00	
5,500.0	13.58	141.38	5,398.0	-690.1	551.4	-693.7	0.00	0.00	0.00	
5,600.0	13.58	141.38	5,495.2	-708.5	566.0	-712.1	0.00	0.00	0.00	
5,700.0	13.58	141.38	5,592.4	-726.8	580.7	-730.6	0.00	0.00	0.00	
5,800.0	13.58	141.38	5,689.6	-745.2	595.4	-749.0	0.00	0.00	0.00	
5,900.0	13.58	141.38	5,786.8	-763.5	610.0	-767.5	0.00	0.00	0.00	
6,000.0	13.58	141.38	5,884.0	-781.9	624.7	-785.9	0.00	0.00	0.00	
6,100.0	13.58	141.38	5,981.2	-800.2	639.3	-804.3	0.00	0.00	0.00	
6,200.0	13.58	141.38	6,078.4	-818.6	654.0	-822.8	0.00	0.00	0.00	
6,300.0	13.58	141.38	6,175.6	-836.9	668.6	-841.2	0.00	0.00	0.00	
6,400.0	13.58	141.38	6,272.9	-855.3	683.3	-859.6	0.00	0.00	0.00	
6,500.0	13.58	141.38	6,370.1	-873.6	698.0	-878.1	0.00	0.00	0.00	
6,575.4	13.58	141.38	6,443.3	-887.4	709.0	-892.0	0.00	0.00	0.00	
6,600.0	13.09	141.38	6,467.3	-891.9	712.6	-896.4	2.00	-2.00	0.00	
6,700.0	11.09	141.38	6,565.1	-908.2	725.6	-912.9	2.00	-2.00	0.00	
6,800.0	9.09	141.38	6,663.5	-921.9	736.6	-926.6	2.00	-2.00	0.00	
6,900.0	7.09	141.38	6,762.5	-932.9	745.3	-937.7	2.00	-2.00	0.00	
7,000.0	5.09	141.38	6,861.9	-941.2	752.0	-946.0	2.00	-2.00	0.00	
7,100.0	3.09	141.38	6,961.7	-946.8	756.4	-951.6	2.00	-2.00	0.00	
7,200.0	1.09	141.38	7,061.6	-949.6	758.7	-954.5	2.00	-2.00	0.00	
7,254.4	0.00	0.00	7,116.0	-950.0	759.0	-954.9	2.00	-2.00	0.00	
7,300.0	0.00	0.00	7,161.6	-950.0	759.0	-954.9	0.00	0.00	0.00	
7,400.0	0.00	0.00	7,261.6	-950.0	759.0	-954.9	0.00	0.00	0.00	
7,500.0	0.00	0.00	7,361.6	-950.0	759.0	-954.9	0.00	0.00	0.00	
7,600.0	0.00	0.00	7,461.6	-950.0	759.0	-954.9	0.00	0.00	0.00	
7,700.0	0.00	0.00	7,561.6	-950.0	759.0	-954.9	0.00	0.00	0.00	
7,800.0	0.00	0.00	7,661.6	-950.0	759.0	-954.9	0.00	0.00	0.00	
7,900.0	0.00	0.00	7,761.6	-950.0	759.0	-954.9	0.00	0.00	0.00	
8,000.0	0.00	0.00	7,861.6	-950.0	759.0	-954.9	0.00	0.00	0.00	
8,100.0	0.00	0.00	7,961.6	-950.0	759.0	-954.9	0.00	0.00	0.00	
8,200.0	0.00	0.00	8,061.6	-950.0	759.0	-954.9	0.00	0.00	0.00	
8,300.0	0.00	0.00	8,161.6	-950.0	759.0	-954.9	0.00	0.00	0.00	
8,400.0	0.00	0.00	8,261.6	-950.0	759.0	-954.9	0.00	0.00	0.00	
8,500.0	0.00	0.00	8,361.6	-950.0	759.0	-954.9	0.00	0.00	0.00	
8,600.0	0.00	0.00	8,461.6	-950.0	759.0	-954.9	0.00	0.00	0.00	
8,700.0	0.00	0.00	8,561.6	-950.0	759.0	-954.9	0.00	0.00	0.00	
8,800.0	0.00	0.00	8,661.6	-950.0	759.0	-954.9	0.00	0.00	0.00	
8,900.0	0.00	0.00	8,761.6	-950.0	759.0	-954.9	0.00	0.00	0.00	
9,000.0	0.00	0.00	8,861.6	-950.0	759.0	-954.9	0.00	0.00	0.00	
9,100.0	0.00	0.00	8,961.6	-950.0	759.0	-954.9	0.00	0.00	0.00	
9,200.0	0.00	0.00	9,061.6	-950.0	759.0	-954.9	0.00	0.00	0.00	
9,300.0	0.00	0.00	9,161.6	-950.0	759.0	-954.9	0.00	0.00	0.00	
9,400.0	0.00	0.00	9,261.6	-950.0	759.0	-954.9	0.00	0.00	0.00	
9,500.0	0.00	0.00	9,361.6	-950.0	759.0	-954.9	0.00	0.00	0.00	
9,579.9	0.00	0.00	9,441.5	-950.0	759.0	-954.9	0.00	0.00	0.00	
9,600.0	2.41	0.00	9,461.6	-949.6	759.0	-954.5	12.00	12.00	0.00	
9,625.0	5.41	0.00	9,486.5	-947.9	759.0	-952.8	12.00	12.00	0.00	
9,650.0	8.41	0.00	9,511.4	-944.9	759.0	-949.7	12.00	12.00	0.00	
9,675.0	11.41	0.00	9,536.0	-940.6	759.0	-945.4	12.00	12.00	0.00	
9,700.0	14.41	0.00	9,560.3	-935.0	759.0	-939.9	12.00	12.00	0.00	
9,725.0	17.42	0.00	9,584.4	-928.1	759.0	-933.0	12.00	12.00	0.00	
9,750.0	20.42	0.00	9,608.0	-920.0	759.0	-924.9	12.00	12.00	0.00	
9,775.0	23.42	0.00	9,631.2	-910.7	759.0	-915.6	12.00	12.00	0.00	



Planning Report

Database:	PEDMB	Local Co-ordinate Reference:	Well #324H
Company:	Midland	TVD Reference:	KB = 32' @ 3687.0usft
Project:	Lea County, NM (NAD 83 NME)	MD Reference:	KB = 32' @ 3687.0usft
Site:	Pegasus 3 Fed Com	North Reference:	Grid
Well:	#324H	Survey Calculation Method:	Minimum Curvature
Wellbore:	OH		
Design:	Plan #0.1		

Planned Survey										
Measured Depth (usft)	Inclination (°)	Azimuth (°)	Vertical Depth (usft)	+N/-S (usft)	+E/-W (usft)	Vertical Section (usft)	Dogleg Rate (°/100usft)	Build Rate (°/100usft)	Turn Rate (°/100usft)	
9,800.3	26.46	0.00	9,654.2	-900.0	759.0	-904.9	12.00	12.00	0.00	
9,825.0	29.42	359.95	9,676.0	-888.4	759.0	-893.3	12.00	12.00	-0.20	
9,850.0	32.42	359.91	9,697.4	-875.6	759.0	-880.5	12.00	12.00	-0.17	
9,875.0	35.42	359.87	9,718.2	-861.7	759.0	-866.5	12.00	12.00	-0.14	
9,900.0	38.42	359.84	9,738.2	-846.6	758.9	-851.5	12.00	12.00	-0.12	
9,925.0	41.42	359.82	9,757.3	-830.6	758.9	-835.5	12.00	12.00	-0.11	
9,950.0	44.42	359.79	9,775.6	-813.6	758.8	-818.5	12.00	12.00	-0.09	
9,975.0	47.42	359.77	9,793.0	-795.6	758.7	-800.5	12.00	12.00	-0.09	
10,000.0	50.42	359.75	9,809.5	-776.8	758.7	-781.7	12.00	12.00	-0.08	
10,025.0	53.42	359.73	9,824.9	-757.1	758.6	-762.0	12.00	12.00	-0.07	
10,050.0	56.42	359.72	9,839.2	-736.7	758.5	-741.5	12.00	12.00	-0.07	
10,075.0	59.42	359.70	9,852.5	-715.5	758.4	-720.4	12.00	12.00	-0.06	
10,100.0	62.42	359.69	9,864.7	-693.6	758.3	-698.5	12.00	12.00	-0.06	
10,125.0	65.42	359.67	9,875.7	-671.2	758.1	-676.1	12.00	12.00	-0.05	
10,150.0	68.42	359.66	9,885.5	-648.2	758.0	-653.1	12.00	12.00	-0.05	
10,175.0	71.42	359.65	9,894.0	-624.7	757.9	-629.6	12.00	12.00	-0.05	
10,200.0	74.42	359.64	9,901.4	-600.8	757.7	-605.7	12.00	12.00	-0.05	
10,225.0	77.42	359.63	9,907.5	-576.6	757.5	-581.5	12.00	12.00	-0.05	
10,250.0	80.42	359.61	9,912.3	-552.0	757.4	-556.9	12.00	12.00	-0.05	
10,275.0	83.42	359.60	9,915.8	-527.3	757.2	-532.2	12.00	12.00	-0.04	
10,300.0	86.42	359.59	9,918.0	-502.4	757.0	-507.3	12.00	12.00	-0.04	
10,325.0	89.42	359.58	9,918.9	-477.4	756.9	-482.3	12.00	12.00	-0.04	
10,329.8	90.00	359.58	9,918.9	-472.6	756.8	-477.5	12.00	12.00	-0.04	
10,400.0	90.00	359.58	9,919.0	-402.4	756.3	-407.3	0.00	0.00	0.00	
10,500.0	90.00	359.58	9,919.0	-302.4	755.6	-307.3	0.00	0.00	0.00	
10,600.0	90.00	359.58	9,919.0	-202.4	754.8	-207.3	0.00	0.00	0.00	
10,700.0	90.00	359.58	9,919.0	-102.4	754.1	-107.3	0.00	0.00	0.00	
10,800.0	90.00	359.58	9,919.0	-2.4	753.4	-7.3	0.00	0.00	0.00	
10,900.0	90.00	359.58	9,919.0	97.6	752.6	92.7	0.00	0.00	0.00	
11,000.0	90.00	359.58	9,919.0	197.6	751.9	192.7	0.00	0.00	0.00	
11,100.0	90.00	359.58	9,919.0	297.6	751.2	292.7	0.00	0.00	0.00	
11,122.4	90.00	359.58	9,919.0	320.0	751.0	315.1	0.00	0.00	0.00	
11,200.0	90.00	359.58	9,919.0	397.6	750.4	392.7	0.00	0.00	0.00	
11,300.0	90.00	359.59	9,919.0	497.6	749.7	492.7	0.00	0.00	0.00	
11,400.0	90.00	359.59	9,919.0	597.6	749.0	592.7	0.00	0.00	0.00	
11,500.0	90.00	359.60	9,919.0	697.6	748.3	692.7	0.00	0.00	0.00	
11,600.0	90.00	359.60	9,919.0	797.6	747.6	792.7	0.00	0.00	0.00	
11,700.0	90.00	359.61	9,919.0	897.5	746.9	892.7	0.00	0.00	0.00	
11,800.0	90.00	359.61	9,919.0	997.5	746.2	992.7	0.00	0.00	0.00	
11,900.0	90.00	359.61	9,919.0	1,097.5	745.5	1,092.7	0.00	0.00	0.00	
12,000.0	90.00	359.62	9,919.0	1,197.5	744.9	1,192.7	0.00	0.00	0.00	
12,100.0	90.00	359.62	9,919.0	1,297.5	744.2	1,292.7	0.00	0.00	0.00	
12,200.0	90.00	359.63	9,919.0	1,397.5	743.5	1,392.7	0.00	0.00	0.00	
12,300.0	90.00	359.63	9,919.0	1,497.5	742.9	1,492.7	0.00	0.00	0.00	
12,400.0	90.00	359.64	9,919.0	1,597.5	742.3	1,592.7	0.00	0.00	0.00	
12,441.5	90.00	359.64	9,919.0	1,639.0	742.0	1,634.2	0.00	0.00	0.00	
12,500.0	90.00	359.64	9,919.0	1,697.5	741.6	1,692.7	0.00	0.00	0.00	
12,600.0	90.00	359.64	9,919.0	1,797.5	741.0	1,792.7	0.00	0.00	0.00	
12,700.0	90.00	359.64	9,919.0	1,897.5	740.4	1,892.7	0.00	0.00	0.00	
12,800.0	90.00	359.64	9,919.0	1,997.5	739.7	1,992.7	0.00	0.00	0.00	
12,900.0	90.00	359.64	9,919.0	2,097.5	739.1	2,092.7	0.00	0.00	0.00	
13,000.0	90.00	359.64	9,919.0	2,197.5	738.5	2,192.7	0.00	0.00	0.00	
13,100.0	90.00	359.63	9,919.0	2,297.5	737.8	2,292.7	0.00	0.00	0.00	
13,200.0	90.00	359.63	9,919.0	2,397.5	737.2	2,392.7	0.00	0.00	0.00	



Planning Report

Database:	PEDMB	Local Co-ordinate Reference:	Well #324H
Company:	Midland	TVD Reference:	KB = 32' @ 3687.0usft
Project:	Lea County, NM (NAD 83 NME)	MD Reference:	KB = 32' @ 3687.0usft
Site:	Pegasus 3 Fed Com	North Reference:	Grid
Well:	#324H	Survey Calculation Method:	Minimum Curvature
Wellbore:	OH		
Design:	Plan #0.1		

Planned Survey										
Measured Depth (usft)	Inclination (°)	Azimuth (°)	Vertical Depth (usft)	+N/-S (usft)	+E/-W (usft)	Vertical Section (usft)	Dogleg Rate (°/100usft)	Build Rate (°/100usft)	Turn Rate (°/100usft)	
13,300.0	90.00	359.63	9,919.0	2,497.5	736.5	2,492.7	0.00	0.00	0.00	
13,400.0	90.00	359.63	9,919.0	2,597.5	735.9	2,592.7	0.00	0.00	0.00	
13,500.0	90.00	359.63	9,919.0	2,697.5	735.3	2,692.7	0.00	0.00	0.00	
13,600.0	90.00	359.63	9,919.0	2,797.5	734.6	2,792.7	0.00	0.00	0.00	
13,700.0	90.00	359.63	9,919.0	2,897.5	734.0	2,892.7	0.00	0.00	0.00	
13,800.0	90.00	359.63	9,919.0	2,997.5	733.3	2,992.7	0.00	0.00	0.00	
13,900.0	90.00	359.63	9,919.0	3,097.5	732.7	3,092.7	0.00	0.00	0.00	
14,000.0	90.00	359.63	9,919.0	3,197.5	732.0	3,192.7	0.00	0.00	0.00	
14,100.0	90.00	359.63	9,919.0	3,297.5	731.4	3,292.7	0.00	0.00	0.00	
14,200.0	90.00	359.63	9,919.0	3,397.5	730.7	3,392.7	0.00	0.00	0.00	
14,300.0	90.00	359.63	9,919.0	3,497.5	730.1	3,492.7	0.00	0.00	0.00	
14,400.0	90.00	359.62	9,919.0	3,597.5	729.4	3,592.7	0.00	0.00	0.00	
14,500.0	90.00	359.62	9,919.0	3,697.5	728.8	3,692.7	0.00	0.00	0.00	
14,600.0	90.00	359.62	9,919.0	3,797.5	728.1	3,792.7	0.00	0.00	0.00	
14,700.0	90.00	359.62	9,919.0	3,897.5	727.5	3,892.7	0.00	0.00	0.00	
14,800.0	90.00	359.62	9,919.0	3,997.5	726.8	3,992.7	0.00	0.00	0.00	
14,900.0	90.00	359.62	9,919.0	4,097.5	726.1	4,092.7	0.00	0.00	0.00	
15,000.0	90.00	359.62	9,919.0	4,197.5	725.5	4,192.7	0.00	0.00	0.00	
15,070.5	90.00	359.62	9,919.0	4,268.0	725.0	4,263.2	0.00	0.00	0.00	
15,100.0	90.00	359.62	9,919.0	4,297.5	724.8	4,292.7	0.00	0.00	0.00	
15,200.0	90.00	359.62	9,919.0	4,397.5	724.1	4,392.7	0.00	0.00	0.00	
15,300.0	90.00	359.62	9,919.0	4,497.5	723.5	4,492.7	0.00	0.00	0.00	
15,400.0	90.00	359.62	9,919.0	4,597.5	722.8	4,592.7	0.00	0.00	0.00	
15,500.0	90.00	359.62	9,919.0	4,697.5	722.2	4,692.7	0.00	0.00	0.00	
15,600.0	90.00	359.62	9,919.0	4,797.5	721.5	4,792.7	0.00	0.00	0.00	
15,700.0	90.00	359.62	9,919.0	4,897.5	720.8	4,892.7	0.00	0.00	0.00	
15,800.0	90.00	359.62	9,919.0	4,997.5	720.2	4,992.7	0.00	0.00	0.00	
15,900.0	90.00	359.62	9,919.0	5,097.5	719.5	5,092.7	0.00	0.00	0.00	
16,000.0	90.00	359.63	9,919.1	5,197.5	718.9	5,192.7	0.00	0.00	0.00	
16,100.0	90.00	359.63	9,919.1	5,297.5	718.2	5,292.7	0.00	0.00	0.00	
16,200.0	90.00	359.63	9,919.1	5,397.5	717.6	5,392.7	0.00	0.00	0.00	
16,300.0	90.00	359.63	9,919.1	5,497.5	716.9	5,492.7	0.00	0.00	0.00	
16,400.0	90.00	359.63	9,919.1	5,597.4	716.3	5,592.7	0.00	0.00	0.00	
16,500.0	90.00	359.63	9,919.1	5,697.4	715.6	5,692.7	0.00	0.00	0.00	
16,600.0	90.00	359.63	9,919.1	5,797.4	715.0	5,792.7	0.00	0.00	0.00	
16,700.0	90.00	359.63	9,919.1	5,897.4	714.3	5,892.7	0.00	0.00	0.00	
16,800.0	90.00	359.63	9,919.1	5,997.4	713.7	5,992.7	0.00	0.00	0.00	
16,900.0	90.00	359.63	9,919.1	6,097.4	713.0	6,092.7	0.00	0.00	0.00	
17,000.0	90.00	359.63	9,919.1	6,197.4	712.4	6,192.7	0.00	0.00	0.00	
17,100.0	90.00	359.63	9,919.1	6,297.4	711.7	6,292.7	0.00	0.00	0.00	
17,200.0	90.00	359.63	9,919.1	6,397.4	711.1	6,392.7	0.00	0.00	0.00	
17,300.0	90.00	359.63	9,919.1	6,497.4	710.5	6,492.7	0.00	0.00	0.00	
17,400.0	90.00	359.63	9,919.1	6,597.4	709.8	6,592.7	0.00	0.00	0.00	
17,500.0	90.00	359.63	9,919.1	6,697.4	709.2	6,692.7	0.00	0.00	0.00	
17,600.0	90.00	359.64	9,919.1	6,797.4	708.6	6,792.7	0.00	0.00	0.00	
17,700.0	90.00	359.64	9,919.1	6,897.4	707.9	6,892.7	0.00	0.00	0.00	
17,800.0	90.00	359.64	9,919.1	6,997.4	707.3	6,992.7	0.00	0.00	0.00	
17,900.0	90.00	359.64	9,919.1	7,097.4	706.6	7,092.7	0.00	0.00	0.00	
18,000.0	90.00	359.64	9,919.1	7,197.4	706.0	7,192.7	0.00	0.00	0.00	
18,100.0	90.00	359.64	9,919.1	7,297.4	705.4	7,292.7	0.00	0.00	0.00	
18,200.0	90.00	359.64	9,919.1	7,397.4	704.7	7,392.7	0.00	0.00	0.00	
18,300.0	90.00	359.64	9,919.1	7,497.4	704.1	7,492.7	0.00	0.00	0.00	
18,400.0	90.00	359.64	9,919.1	7,597.4	703.5	7,592.7	0.00	0.00	0.00	
18,500.0	90.00	359.64	9,919.1	7,697.4	702.9	7,692.7	0.00	0.00	0.00	



Planning Report

Database:	PEDMB	Local Co-ordinate Reference:	Well #324H
Company:	Midland	TVD Reference:	KB = 32' @ 3687.0usft
Project:	Lea County, NM (NAD 83 NME)	MD Reference:	KB = 32' @ 3687.0usft
Site:	Pegasus 3 Fed Com	North Reference:	Grid
Well:	#324H	Survey Calculation Method:	Minimum Curvature
Wellbore:	OH		
Design:	Plan #0.1		

Planned Survey										
Measured Depth (usft)	Inclination (°)	Azimuth (°)	Vertical Depth (usft)	+N/-S (usft)	+E/-W (usft)	Vertical Section (usft)	Dogleg Rate (°/100usft)	Build Rate (°/100usft)	Turn Rate (°/100usft)	
18,600.0	90.00	359.64	9,919.1	7,797.4	702.2	7,792.7	0.00	0.00	0.00	
18,700.0	90.00	359.64	9,919.1	7,897.4	701.6	7,892.7	0.00	0.00	0.00	
18,800.0	90.00	359.64	9,919.1	7,997.4	701.0	7,992.7	0.00	0.00	0.00	
18,900.0	90.00	359.64	9,919.1	8,097.4	700.4	8,092.7	0.00	0.00	0.00	
19,000.0	90.00	359.64	9,919.1	8,197.4	699.7	8,192.7	0.00	0.00	0.00	
19,100.0	90.00	359.64	9,919.1	8,297.4	699.1	8,292.7	0.00	0.00	0.00	
19,200.0	90.00	359.64	9,919.1	8,397.4	698.5	8,392.7	0.00	0.00	0.00	
19,300.0	90.00	359.65	9,919.1	8,497.4	697.9	8,492.7	0.00	0.00	0.00	
19,400.0	90.00	359.65	9,919.0	8,597.4	697.3	8,592.7	0.00	0.00	0.00	
19,500.0	90.00	359.65	9,919.0	8,697.4	696.6	8,692.7	0.00	0.00	0.00	
19,600.0	90.00	359.65	9,919.0	8,797.4	696.0	8,792.7	0.00	0.00	0.00	
19,700.0	90.00	359.65	9,919.0	8,897.4	695.4	8,892.7	0.00	0.00	0.00	
19,800.0	90.00	359.65	9,919.0	8,997.4	694.8	8,992.7	0.00	0.00	0.00	
19,900.0	90.00	359.65	9,919.0	9,097.4	694.2	9,092.7	0.00	0.00	0.00	
20,000.0	90.00	359.65	9,919.0	9,197.4	693.6	9,192.7	0.00	0.00	0.00	
20,100.0	90.00	359.65	9,919.0	9,297.4	693.0	9,292.7	0.00	0.00	0.00	
20,200.0	90.00	359.65	9,919.0	9,397.4	692.4	9,392.7	0.00	0.00	0.00	
20,257.6	90.00	359.65	9,919.0	9,455.0	692.0	9,450.3	0.00	0.00	0.00	

Design Targets									
Target Name - hit/miss target - Shape	Dip Angle (°)	Dip Dir. (°)	TVD (usft)	+N/-S (usft)	+E/-W (usft)	Northing (usft)	Easting (usft)	Latitude	Longitude
KOP(Pegasus 3 Fed Co - plan hits target center - Point	0.00	0.00	9,441.5	-950.0	759.0	451,496.00	747,976.00	32° 14' 22.095 N	103° 39' 53.984 W
FTP(Pegasus 3 Fed Cor - plan hits target center - Point	0.00	0.00	9,654.2	-900.0	759.0	451,546.00	747,976.00	32° 14' 22.590 N	103° 39' 53.980 W
Fed Perf #2(Pegasus 3 I - plan hits target center - Point	0.00	0.00	9,919.0	1,639.0	742.0	454,085.00	747,959.00	32° 14' 47.716 N	103° 39' 53.994 W
Fed Perf #1(Pegasus 3 I - plan hits target center - Point	0.00	0.00	9,919.0	320.0	751.0	452,766.00	747,968.00	32° 14' 34.663 N	103° 39' 53.985 W
PBHL(Pegasus 3 Fed C - plan hits target center - Point	0.00	0.00	9,919.0	9,455.0	692.0	461,901.00	747,909.00	32° 16' 5.061 N	103° 39' 54.010 W
Fed Perf #3(Pegasus 3 I - plan hits target center - Point	0.00	0.00	9,919.0	4,268.0	725.0	456,714.00	747,942.00	32° 15' 13.731 N	103° 39' 54.002 W

Lea County, NM (NAD 83 NME)

Pegasus 3 Fed Com #324H

Plan #0.1

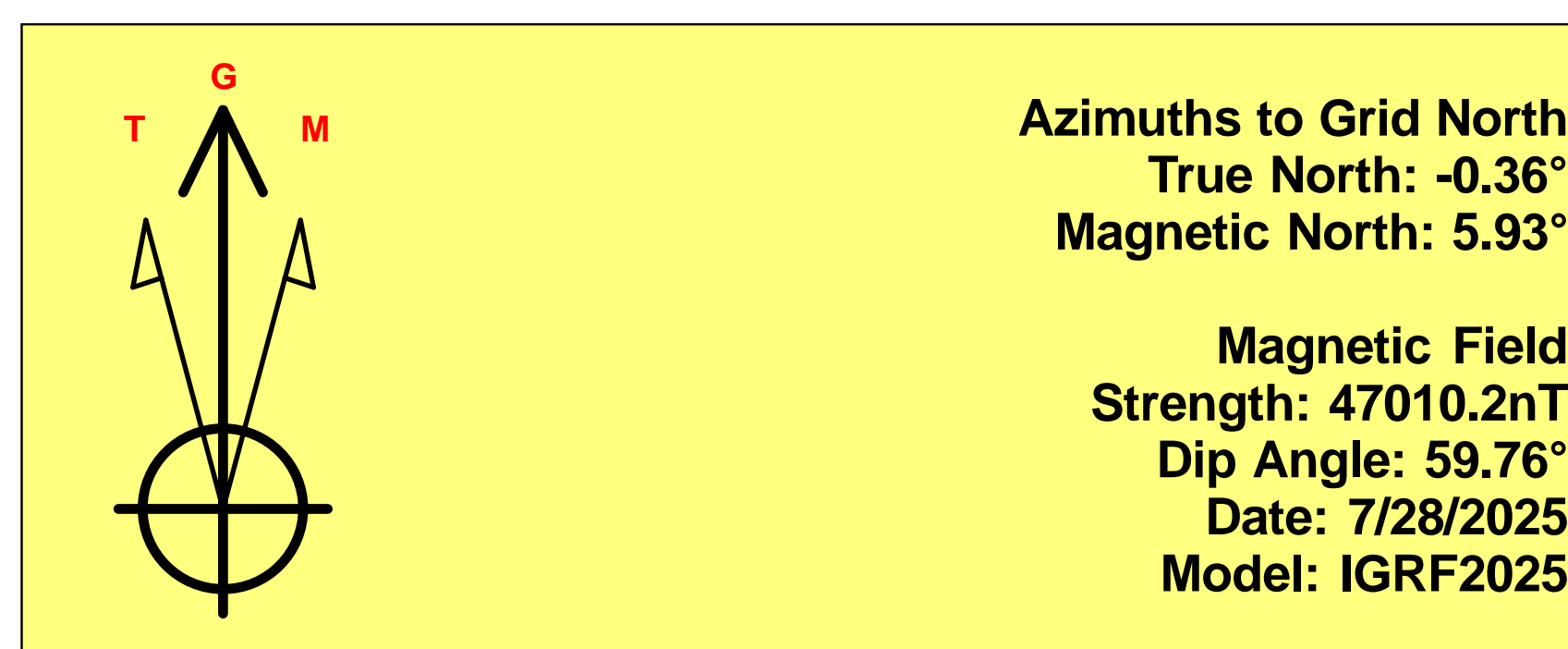

Azimuths to Grid North
True North: -0.36°
Magnetic North: 5.93°

Magnetic Field
Strength: 47010.2nT
Dip Angle: 59.76°
Date: 7/28/2025
Model: IGRF2025

To convert a Magnetic Direction to a Grid Direction, Add 5.93°
To convert a Magnetic Direction to a True Direction, Add 6.29° East
To convert a True Direction to a Grid Direction, Subtract 0.36°

PROJECT DETAILS: Lea County, NM (NAD 83 NME)

Geodetic System: US State Plane 1983
Datum: North American Datum 1983
Ellipsoid: GRS 1980
Zone: New Mexico Eastern Zone
System Datum: Mean Sea Level

WELL DETAILS: #324H

KB = 32' @ 3687.0usft 3655.0
Northing 452446.00 Easting 747217.00 Latitude 32° 14' 31.543 N Longitude 103° 40' 2.752 W

SECTION DETAILS

Sec	MD	Inc	Azi	TVD	+N/-S	+E/-W	Dleg	TFace	VSect	Target
1	0.0	0.00	0.00	0.0	0.0	0.0	0.00	0.00	0.0	
2	1400.0	0.00	0.00	1400.0	0.0	0.0	0.00	0.00	0.0	
3	2079.0	13.58	141.38	2072.7	-62.6	50.0	2.00	141.38	-62.9	
4	6575.4	13.58	141.38	6443.3	-887.4	709.0	0.00	0.00	-892.0	
5	7254.4	0.00	0.00	7116.0	-950.0	759.0	2.00	180.00	-954.9	
6	9579.9	0.00	0.00	9441.5	-950.0	759.0	0.00	0.00	-954.9	KOP(Pegasus 3 Fed Com 324H)
7	9800.3	26.46	0.00	9654.2	-900.0	759.0	12.00	0.00	-904.9	FTP(Pegasus 3 Fed Com 324H)
8	10329.8	90.00	359.58	9918.9	-472.6	756.8	12.00	-0.47	-477.5	
9	11122.4	90.00	359.58	9919.0	320.0	751.0	0.00	0.00	315.1	Fed Perf #1(Pegasus 3 Fed Com 324H)
10	12441.5	90.00	359.64	9919.0	1639.0	742.0	0.00	82.60	1634.2	Fed Perf #2(Pegasus 3 Fed Com 324H)
11	15070.5	90.00	359.62	9919.0	4268.0	725.0	0.00	-111.87	4263.2	Fed Perf #3(Pegasus 3 Fed Com 324H)
12	20257.6	90.00	359.65	9919.0	9455.0	692.0	0.00	76.01	9450.3	PBHL(Pegasus 3 Fed Com 324H)

WELBORE TARGET DETAILS (MAP CO-ORDINATES)

Name	TVD	+N/-S	+E/-W	Northing	Easting
KOP(Pegasus 3 Fed Com 324H)	9441.5	-950.0	759.0	451496.00	747976.00
FTP(Pegasus 3 Fed Com 324H)	9654.2	-900.0	759.0	451546.00	747976.00
Fed Perf #1(Pegasus 3 Fed Com 324H)	9919.0	320.0	751.0	452766.00	747968.00
Fed Perf #2(Pegasus 3 Fed Com 324H)	9919.0	1639.0	742.0	454085.00	747959.00
Fed Perf #3(Pegasus 3 Fed Com 324H)	9919.0	4268.0	725.0	456714.00	747942.00
PBHL(Pegasus 3 Fed Com 324H)	9919.0	9455.0	692.0	461901.00	747909.00

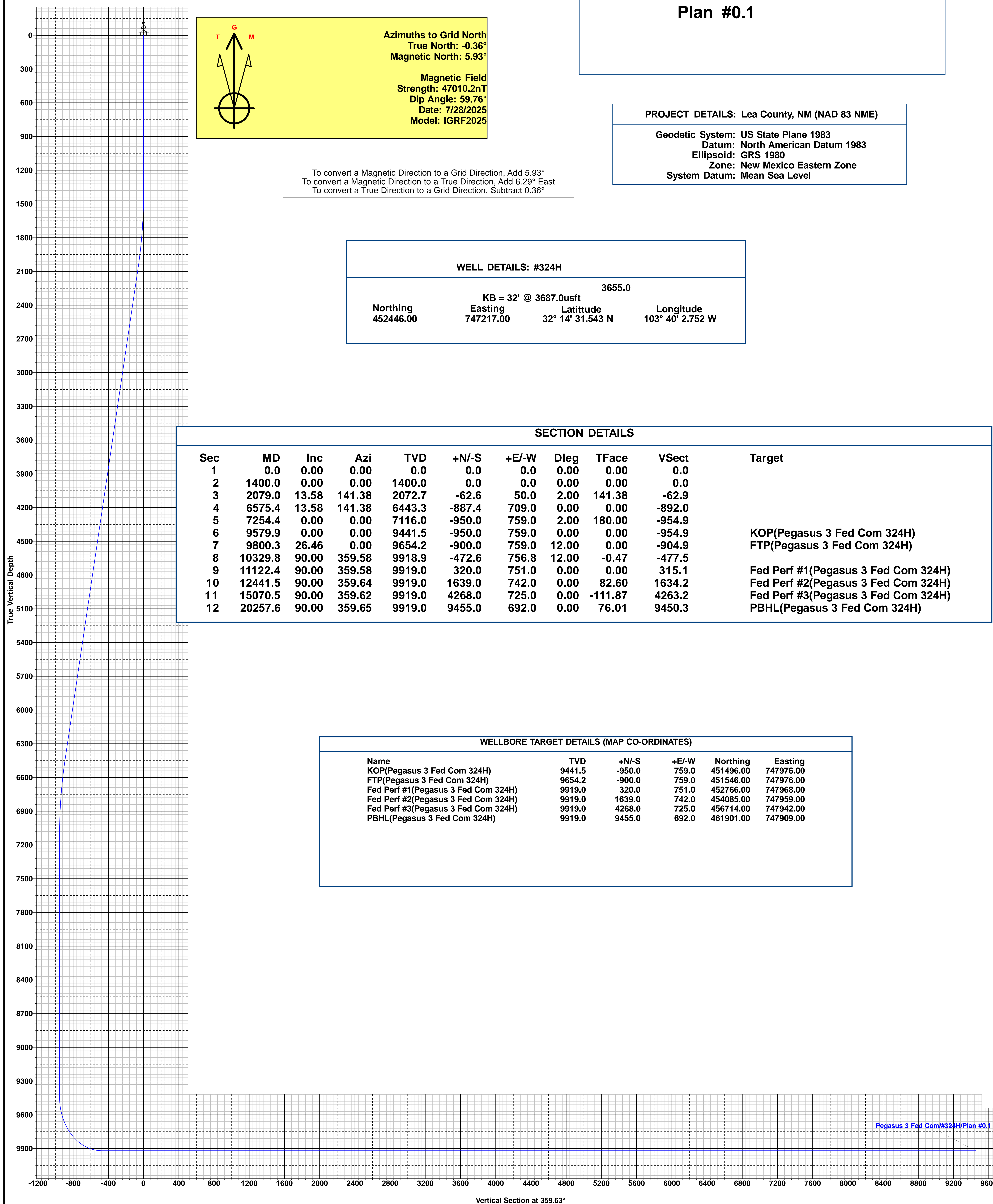

Vertical Section at 359.63°

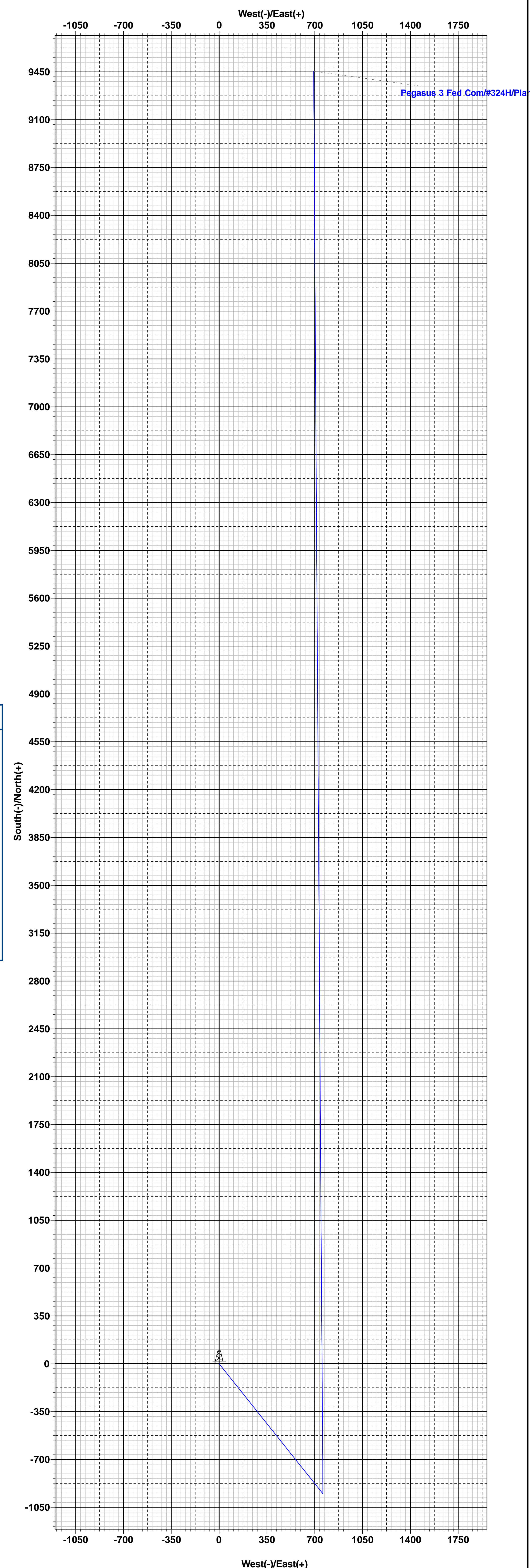



EOG BLANKET CASING DESIGN VARIANCE

EOG respectfully requests the drill plans in the attached document 'EOG BLM Variance 5a - Alternate Shallow Casing Designs' be added to the COA's for this well. These designs have been approved by the BLM down to the TVDs listed below and will allow EOG to run alternate casing designs for this well if necessary.

The designs and associated details listed are the "worst case scenario" boundaries for design safety factors. Location and lithology have NOT been accounted for in these designs. The specific well details will be based on the APD/Sundry package and the information listed in the COA.

The mud program will not change from the original design for this well. Summary of the mud programs for both shallow and deep targets are listed at the end of this document. If the target is changing, a sundry will be filed to update the casing design and mud/cement programs.

Cement volumes listed in this document are for reference only. The cement volumes for the specific well will be adjusted to ensure cement tops meet BLM requirements as listed in the COA and to allow bradenhead cementing when applicable.

This blanket document only applies to wells with three string designs outside of Potash and Capitan Reef boundaries.

Shallow Design Boundary Conditions				
	Deepest MD (ft)	Deepest TVD (ft)	Max Inc (deg)	Max DLS (°/100usft)
Surface	2030	2030	0	0
Intermediate	7793	5650	40	8
Production	28578	12000	90	25



Shallow Design A

4. CASING PROGRAM

Hole Size	Interval MD		Interval TVD		Csg OD	Weight	Grade	Conn
	From (ft)	To (ft)	From (ft)	To (ft)				
16"	0	2,161	0	2,030	13-3/8"	54.5#	J-55	STC
11"	0	7,951	0	5,650	9-5/8"	40#	J-55	LTC
6-3/4"	0	29,353	0	12,000	5-1/2"	20#	P110-EC	DWC/C IS MS

Hole will be full during casing run for well control and tensile SF factor. Casing will be kept at least half full during run for this design to meet BLM collapse SF requirement. External pressure will be reviewed prior to conducting casing pressure tests to ensure that 70% of the yield is not exceeded.

Variance is requested to waive the centralizer requirements for the 9-5/8" casing in the 11" hole size. An expansion additive will be utilized, in the cement slurry, for the entire length of the 11" hole interval to maximize cement bond and zonal isolation.

Variance is also requested to waive any centralizer requirements for the 5-1/2" casing in the 6-3/4" hole size. An expansion additive will be utilized, in the cement slurry, for the entire length of the 6-3/4" hole interval to maximize cement bond and zonal isolation.

EOG requests permission to allow deviation from the 0.422" annulus clearance requirement for the intermediate (salt) section from Title 43 CFR Part 3170 under the following conditions:

- The variance is not applicable within the Potash Boundaries or Capitan Reef areas.
- Operator takes responsibility to get casing to set point in the event that the clearance causes stuck pipe issues.

5. CEMENTING PROGRAM:

Depth	No. Sacks	Wt. ppg	Yld Ft3/sk	Slurry Description
2,030' 13-3/8"	570	13.5	1.73	Lead: Class C/H + 4.0% Bentonite Gel + 0.5% CaCl ₂ + 0.25 lb/sk Cello-Flake (TOC @ Surface)
	160	14.8	1.34	Tail: Class C/H + 0.6% FL-62 + 0.25 lb/sk Cello-Flake + 0.2% Sodium Metasilicate (TOC @ 1830')
8,050' 9-5/8"	760	12.7	2.22	Lead: Class C/H + 10% NaCl + 6% Bentonite Gel + 3% MagOx (TOC @ Surface)
	250	14.8	1.32	Tail: Class C/H + 10% NaCl + 3% MagOx (TOC @ 6360')
29,353' 5-1/2"	1000	14.8	1.32	Bradenhead squeeze: Class C/H + 3% Salt + 1% PreMag-M + 6% Bentonite Gel (TOC @ surface)
	1480	13.2	1.52	Tail: Class C/H + 5% NEX-020 + 0.2% NAC-102 + 0.15% NAS-725 + 0.5% NFL-549 + 0.2% NFP-703 + 1% NBE-737 + 0.3% NRT-241 (TOC @ Top of Brushy)



Shallow Design A

Proposed Wellbore

KB: 3558'

GL: 3533'

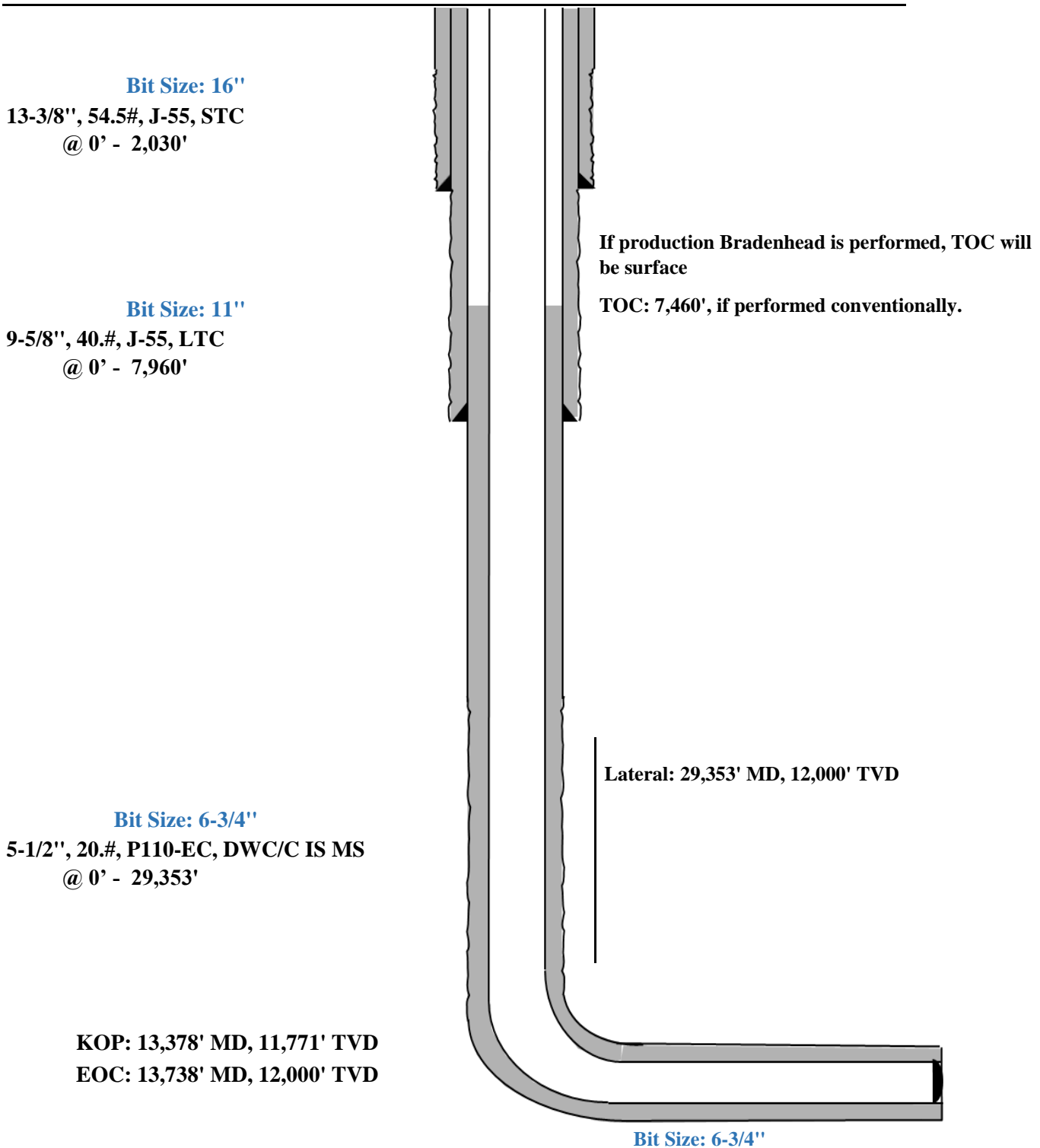

Triaxial Results	Depth (MD) (usft)	Axial Force (lbf)		Equivalent Axial Load (lbf)	Bending Stress at OD (psi)	Absolute Safety Factor				Temperature (°F)	Pressure (psi)		Add'l Pickup To Prevent Buck. (lbf)	Buckled Length (usft)
		Apparent (w/Bending)	Actual (w/o Bending)			Triaxial	Burst	Collapse (V)	Axial		Internal	External		
1	0	252987	228954	253140	2098.2	1.69	1.58	N/A	2.82 F	70.00	2500.00	0.00	N/A	N/A
2	100	247735	223702	248466	2098.2	1.69	1.58	N/A	2.88 F	71.10	2543.63	43.63		
3	100	234996	223701	235716	986.2	1.71	1.58	N/A	3.04 F	71.10	2543.64	43.64		
4	1700	341565	139667	352253	17627.2	1.53	1.57	N/A	2.09 F	88.70	3241.64	741.64		
5	1700	312979	139666	323488	15131.5	1.58	1.57	N/A	2.28 F	88.70	3241.65	741.65		
6	1850	336881	132027	348440	17885.2	1.51	1.57	N/A	2.12 F	90.29	3305.05	805.05		
7	1850	318549	132027	329984	16284.8	1.54	1.57	N/A	2.24 F	90.29	3305.06	805.06		
8	1950	320468	127243	332475	16869.9	1.52	1.57	N/A	2.23 F	91.30	3344.87	844.87		
9	1950	312802	127243	324756	16200.7	1.53	1.57	N/A	2.28 F	91.30	3344.87	844.87		
10	2050	307858	122773	320295	16159.3	1.52	1.57	N/A	2.32 F	92.23	3381.89	881.89		
11	2050	303560	122772	315965	15784.1	1.53	1.57	N/A	2.35 F	92.23	3381.89	881.89		
12	2300	151294	112633	163658	3375.4	1.71	1.57	N/A	4.72 F	94.35	3466.13	966.13		
13	2300	132741	112633	144956	1755.6	1.72	1.57	N/A	5.38 F	94.35	3466.14	966.14		
14	2370	129966	109858	142452	1755.6	1.72	1.57	N/A	5.49 F	94.94	3489.28	989.28		
15	2370	127909	107800	140922	1755.6	1.75	1.60	N/A	5.58 F	94.94	3489.29	1036.40		
16	2700	105515	94232	119785	985.1	1.75	1.60	N/A	6.77 F	97.73	3599.97	1152.35		
17	2700	111680	94231	126006	1523.4	1.75	1.60	N/A	6.39 F	97.73	3599.97	1152.35		
18	3100	110766	77783	126839	2879.6	1.71	1.60	N/A	6.44 F	101.11	3734.23	1293.00		
19	3100	97392	77783	113331	1712.1	1.73	1.60	N/A	7.33 F	101.11	3734.23	1293.01		
20	3700	71565	53303	89806	1594.4	1.70	1.61	N/A	9.97 F	106.15	3934.24	1502.54		
21	3700	60887	53302	79004	662.3	1.71	1.61	N/A	11.72 F	106.16	3934.25	1502.55		
22	4650	34671	14219	56495	1785.6	1.64	1.61	N/A	20.59 F	114.20	4253.37	1836.86		
23	4900	44595	4828	67626	3472.0	1.59	1.61	N/A	16.01 F	116.32	4337.37	1924.87		
24	4900	28975	4828	51775	2108.2	1.62	1.61	N/A	24.64 F	116.32	4337.38	1924.87		
25	5029	22103	34	45340	1926.8	1.61	1.61	N/A	32.30 F	117.40	4380.40	1969.94		
26	5029	22102	33	45339	1926.8	1.61	1.61	N/A	32.30 F	117.40	4380.41	1969.95		
27	5600	-45329	-21341	-20805	2094.3	1.57	1.62	N/A	(13.67)	122.23	4572.11	2170.78		
28	5650	-40465	-23210	-15657	1506.5	1.58	1.62	N/A	(15.31)	122.66	4588.87	2188.34		
29														
30		F	Conn Fracture											
31		()	Compression											
32		(V)	Vector Collapse Safety Factor											
33														

9-5/8" Intermediate Casing Pressure Test:
 Internal Profile based off Surface Pressure + Hydrostatic: 4589 psi
 External Profile based off Pore Pressure: 2188 psi

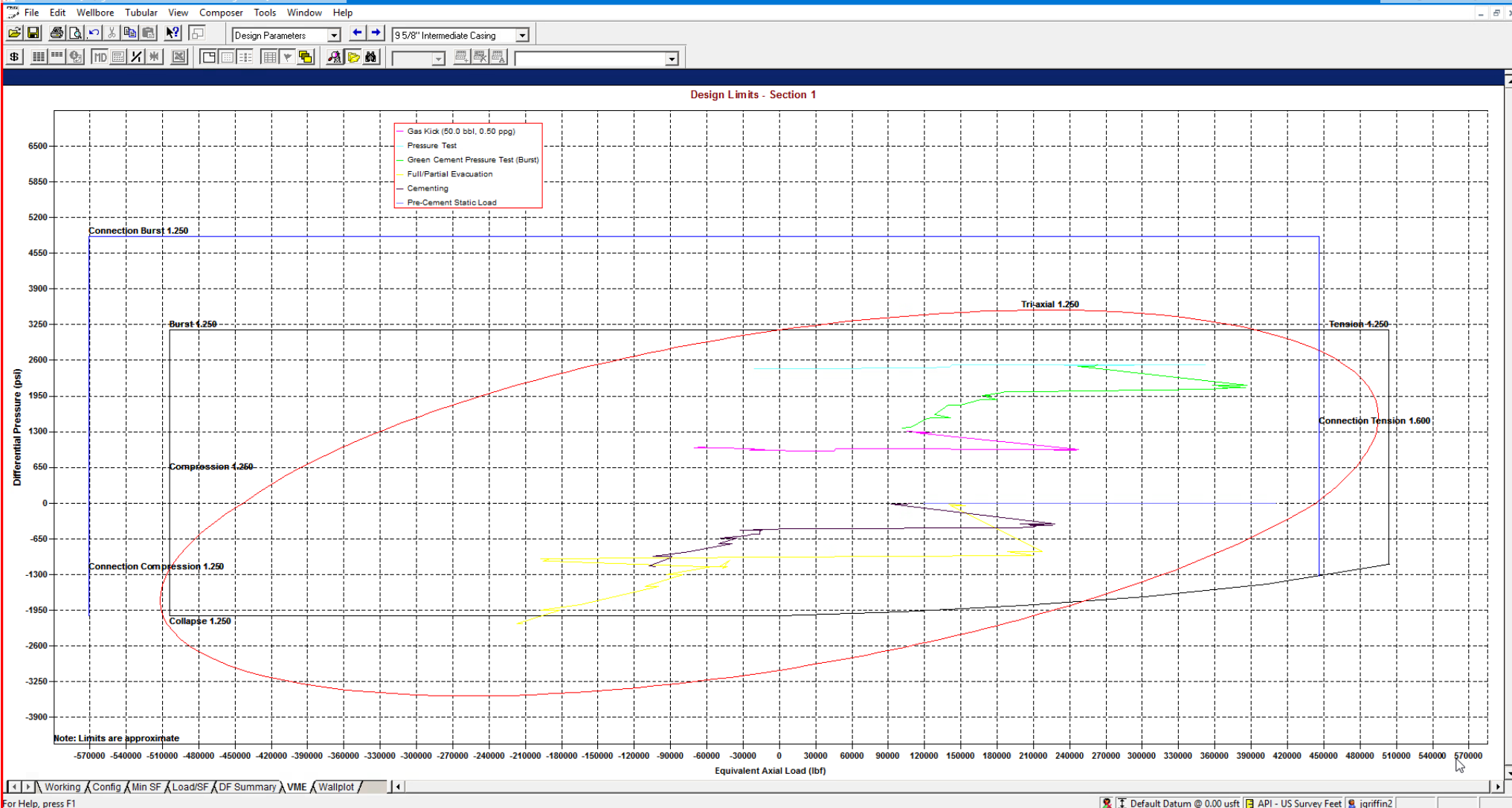

StressCheck - [String Summary - Shallow 3.0 Mile - Big Hole *]

String	OD/Weight/Grade	Connection	MD Interval (usft)	Drift Dia. (")	Minimum Safety Factor (Abs)				Design Cost (\$)
					Burst	Collapse (V)	Axial	Triaxial	
1	Intermediate Casing	BTC, J-55	0.0-5650.0	8.750 A	1.57	1.59	1.80 F	1.35	98,141
2									Total = 98,141
3									
4	F Conn Fracture								
5	A Alternate Drift								
6	(V) Vector Collapse Safety Factor								
7									

*Modelling done with 9-5/8" 40# Intermediate Casing. Passes all Burst, Collapse and Tensile design criteria.

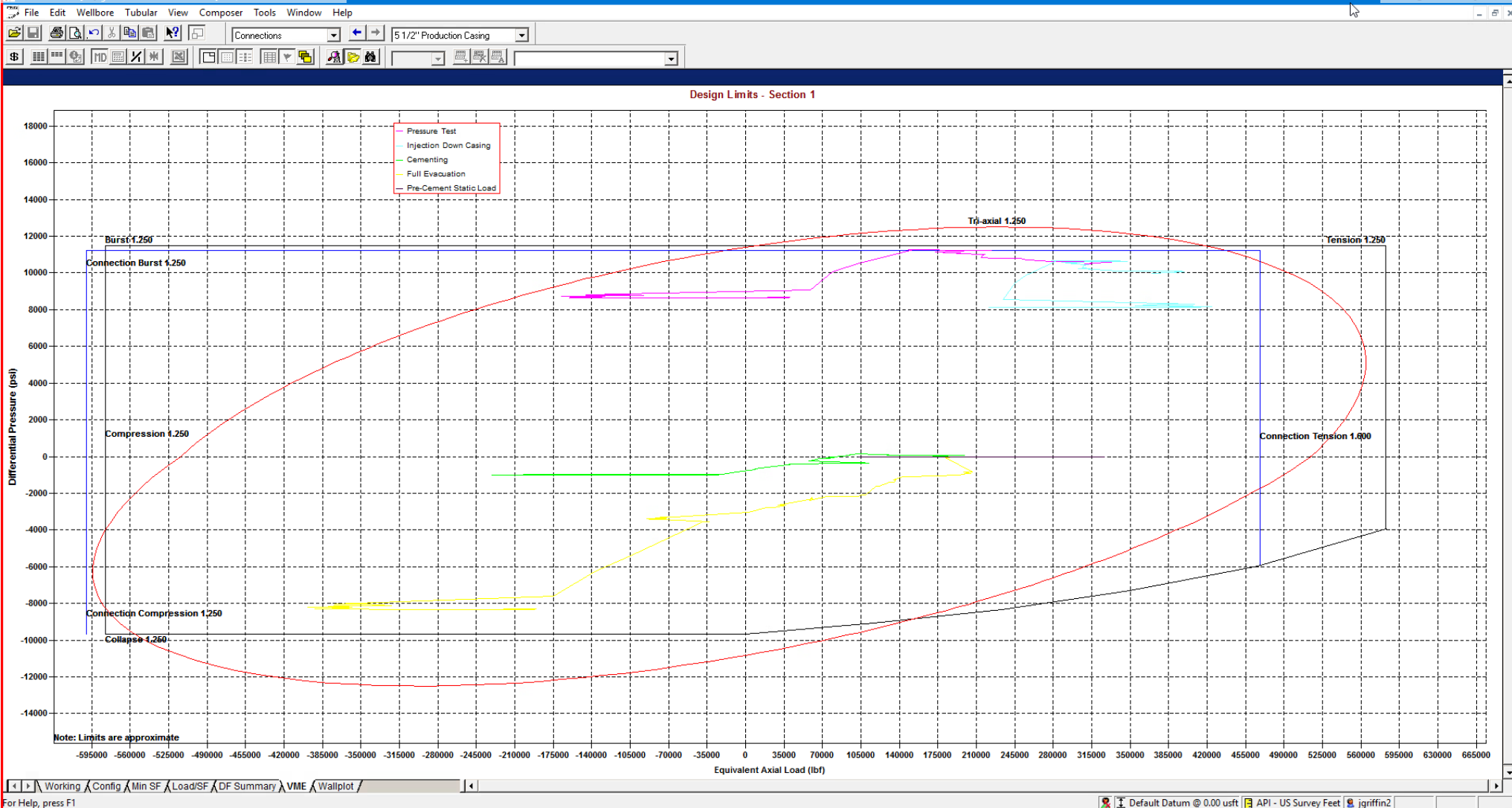

StressCheck - [String Summary - Shallow 3.0 Mile]

String	OD/Weight/Grade	Connection	MD Interval (usft)	Drift Dia. (")	Minimum Safety Factor (Abs)				Design Cost (\$)	
					Burst	Collapse (V)	Axial	Triaxial		
1	Production Casing	5 1/2", 20.000 ppf, P110 ICY	BTC, P110 ICY	0.0-28578.0	4.653	1.27	1.47	1.90 F	1.35	446,902
2										
3										
4	F Conn Fracture									
5	() Compression									
6	(V) Vector Collapse Safety Factor									
7										
Total = 446,902										

*Modelling done with 5-1/2" 20# Production Casing with a 125ksi Control Yield. Passes all Burst, Collapse and Tensile design criteria.



Shallow Design B

4. CASING PROGRAM

Hole Size	Interval MD		Interval TVD		Csg OD	Weight	Grade	Conn
	From (ft)	To (ft)	From (ft)	To (ft)				
13-1/2"	0	2,161	0	2,030	10-3/4"	40.5#	J-55	STC
9-7/8"	0	7,951	0	5,650	8-5/8"	32#	J-55	BTC-SC
6-3/4"	0	29,353	0	12,000	5-1/2"	20#	P110-EC	DWC/C IS MS

Hole will be full during casing run for well control and tensile SF factor. Casing will be kept at least half full during run for this design to meet BLM collapse SF requirement. External pressure will be reviewed prior to conducting casing pressure tests to ensure that 70% of the yield is not exceeded.

Variance is requested to waive the centralizer requirements for the 8-5/8" casing in the 9-7/8" hole size. An expansion additive will be utilized, in the cement slurry, for the entire length of the 9-7/8" hole interval to maximize cement bond and zonal isolation.

Variance is also requested to waive any centralizer requirements for the 5-1/2" casing in the 6-3/4" hole size. An expansion additive will be utilized, in the cement slurry, for the entire length of the 6-3/4" hole interval to maximize cement bond and zonal isolation.

EOG requests permission to allow deviation from the 0.422" annulus clearance requirement for the intermediate (salt) section from Title 43 CFR Part 3170 under the following conditions:

- The variance is not applicable within the Potash Boundaries or Capitan Reef areas.
- Operator takes responsibility to get casing to set point in the event that the clearance causes stuck pipe issues.

5. CEMENTING PROGRAM:

Depth	No. Sacks	Wt. ppg	Yld Ft3/sk	Slurry Description
2,030' 10-3/4"	530	13.5	1.73	Lead: Class C/H + 4.0% Bentonite Gel + 0.5% CaCl ₂ + 0.25 lb/sk Cello-Flake (TOC @ Surface)
	140	14.8	1.34	Tail: Class C/H + 0.6% FL-62 + 0.25 lb/sk Cello-Flake + 0.2% Sodium Metasilicate (TOC @ 1830')
8,050' 8-5/8"	470	12.7	2.22	Lead: Class C/H + 10% NaCl + 6% Bentonite Gel + 3% MagOx (TOC @ Surface)
	210	14.8	1.32	Tail: Class C/H + 10% NaCl + 3% MagOx (TOC @ 6360')
29,353' 5-1/2"	1000	14.8	1.32	Bradenhead squeeze: Class C/H + 3% Salt + 1% PreMag-M + 6% Bentonite Gel (TOC @ surface)
	1480	13.2	1.52	Tail: Class C/H + 5% NEX-020 + 0.2% NAC-102 + 0.15% NAS-725 + 0.5% NFL-549 + 0.2% NFP-703 + 1% NBE-737 + 0.3% NRT-241 (TOC @ Top of Brushy)



Shallow Casing Design B

Proposed Wellbore

KB: 3558'

GL: 3533'

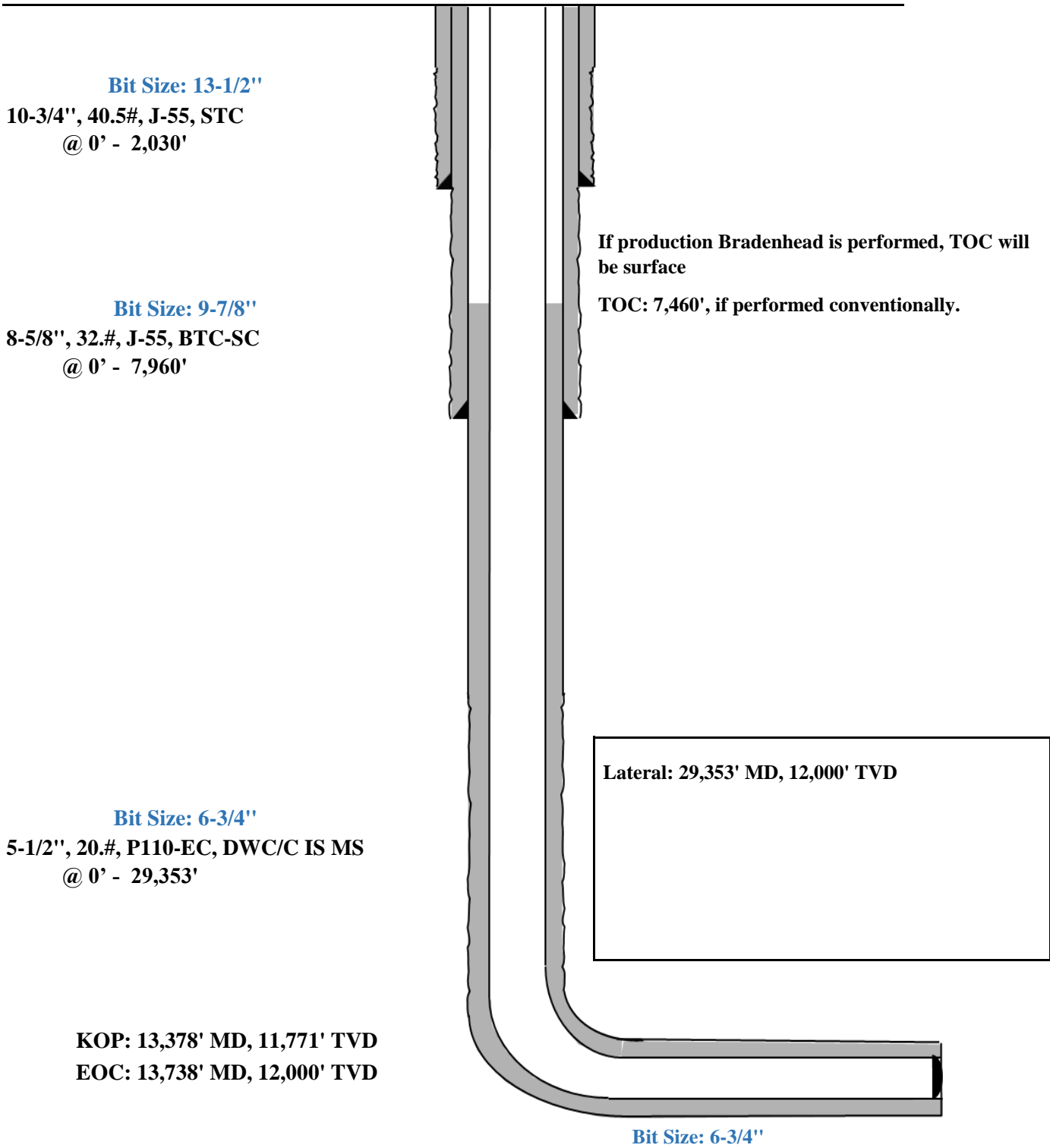

StressCheck - [Triaxial Results - Shallow 3.0 Mile *]

Burst Design | 8 5/8" Intermediate Casing | Pressure Test

Triaxial Results	Depth (MD) (usft)	Axial Force (lbf)		Equivalent Axial Load (lbf)	Bending Stress at OD (psi)	Absolute Safety Factor				Temperature (°F)	Pressure (psi)		Addtl Pickup To Prevent Buck. (lbf)	Buckled Length (usft)
		Apparent (w/Bending)	Actual (w/o Bending)			Triaxial	Burst	Collapse (V)	Axial		Internal	External		
1	0	200426	183224	200546	1880.2	1.68	1.57	N/A	2.89 F	70.00	2500.00	0.00	N/A	N/A
2	100	196229	179028	196812	1880.2	1.69	1.57	N/A	2.95 F	71.10	2543.63	43.63		
3	100	187111	179027	187686	883.7	1.70	1.57	N/A	3.10 F	71.10	2543.64	43.64		
4	1700	256401	111891	264835	15795.8	1.56	1.56	N/A	2.26 F	88.70	3241.64	741.64		
5	1700	235940	111891	244247	13559.4	1.60	1.56	N/A	2.45 F	88.70	3241.65	741.65		
6	1850	252413	105788	261533	16027.0	1.54	1.56	N/A	2.29 F	90.29	3305.05	805.05		
7	1850	239292	105787	248323	14592.9	1.56	1.56	N/A	2.42 F	90.29	3305.06	805.06		
8	1950	240267	101966	249748	15117.2	1.54	1.56	N/A	2.41 F	91.30	3344.87	844.87		
9	1950	234781	101965	244223	14517.5	1.56	1.56	N/A	2.47 F	91.30	3344.87	844.87		
10	2050	230871	98395	240694	14480.4	1.55	1.56	N/A	2.51 F	92.23	3381.89	881.89		
11	2050	227794	98394	237594	14144.2	1.55	1.56	N/A	2.54 F	92.23	3381.89	881.89		
12	2300	117966	90294	127818	3024.7	1.70	1.56	N/A	4.91 F	94.35	3466.13	966.13		
13	2300	104686	90293	114432	1573.2	1.71	1.56	N/A	5.53 F	94.35	3466.14	966.14		
14	2370	102469	88077	112431	1573.2	1.71	1.56	N/A	5.65 F	94.94	3489.28	989.28		
15	2370	100817	86424	111200	1573.2	1.75	1.59	N/A	5.75 F	94.94	3489.29	1036.40		
16	2700	83660	75583	95052	882.8	1.74	1.59	N/A	6.92 F	97.73	3599.97	1152.35		
17	2700	88072	75583	99504	1365.1	1.74	1.59	N/A	6.58 F	97.73	3599.97	1152.35		
18	3100	86049	62442	98863	2580.4	1.71	1.59	N/A	6.73 F	101.11	3734.23	1293.00		
19	3100	76477	62441	89195	1534.2	1.72	1.59	N/A	7.57 F	101.11	3734.23	1293.01		
20	3700	55953	42882	70509	1428.8	1.69	1.60	N/A	10.35 F	106.15	3934.24	1502.54		
21	3700	48311	42881	62778	593.5	1.71	1.60	N/A	11.99 F	106.16	3934.25	1502.55		
22	4000	41458	33043	56865	919.9	1.69	1.60	N/A	13.97 F	108.69	4034.82	1607.91		
23	4650	26293	11655	43706	1600.1	1.63	1.60	N/A	22.03 F	114.20	4253.37	1836.86		
24	4900	32619	4156	50970	3111.2	1.59	1.60	N/A	17.76 F	116.32	4337.37	1924.87		
25	4900	21439	4155	39625	1889.2	1.61	1.60	N/A	27.02 F	116.32	4337.38	1924.87		
26	5039	15822	26	34389	1726.6	1.61	1.61	N/A	36.61 F	117.49	4383.77	1973.48		
27	5039	15822	26	34388	1726.6	1.61	1.61	N/A	36.61 F	117.49	4383.78	1973.49		
28	5600	-33912	-16743	-14286	1876.7	1.57	1.61	N/A	(14.60)	122.23	4572.11	2170.78		
29	5650	-30585	-18235	-10742	1350.0	1.58	1.61	N/A	(16.18)	122.66	4588.87	2188.34		
30														
31		F	Conn Fracture											
32		(Compression											
33		(V)	Vector Collapse Safety Factor											
34														

Working | Config | Min SF | Load/SF | DF Summary | VME | Wallplot

For Help, press F1 | Default Datum @ 0.00 usft | API - US Survey Feet | jgriffin2

8-5/8" Intermediate Casing Pressure Test:
 Internal Profile based off Surface Pressure + Hydrostatic: 4589 psi
 External Profile based off Pore Pressure: 2188 psi

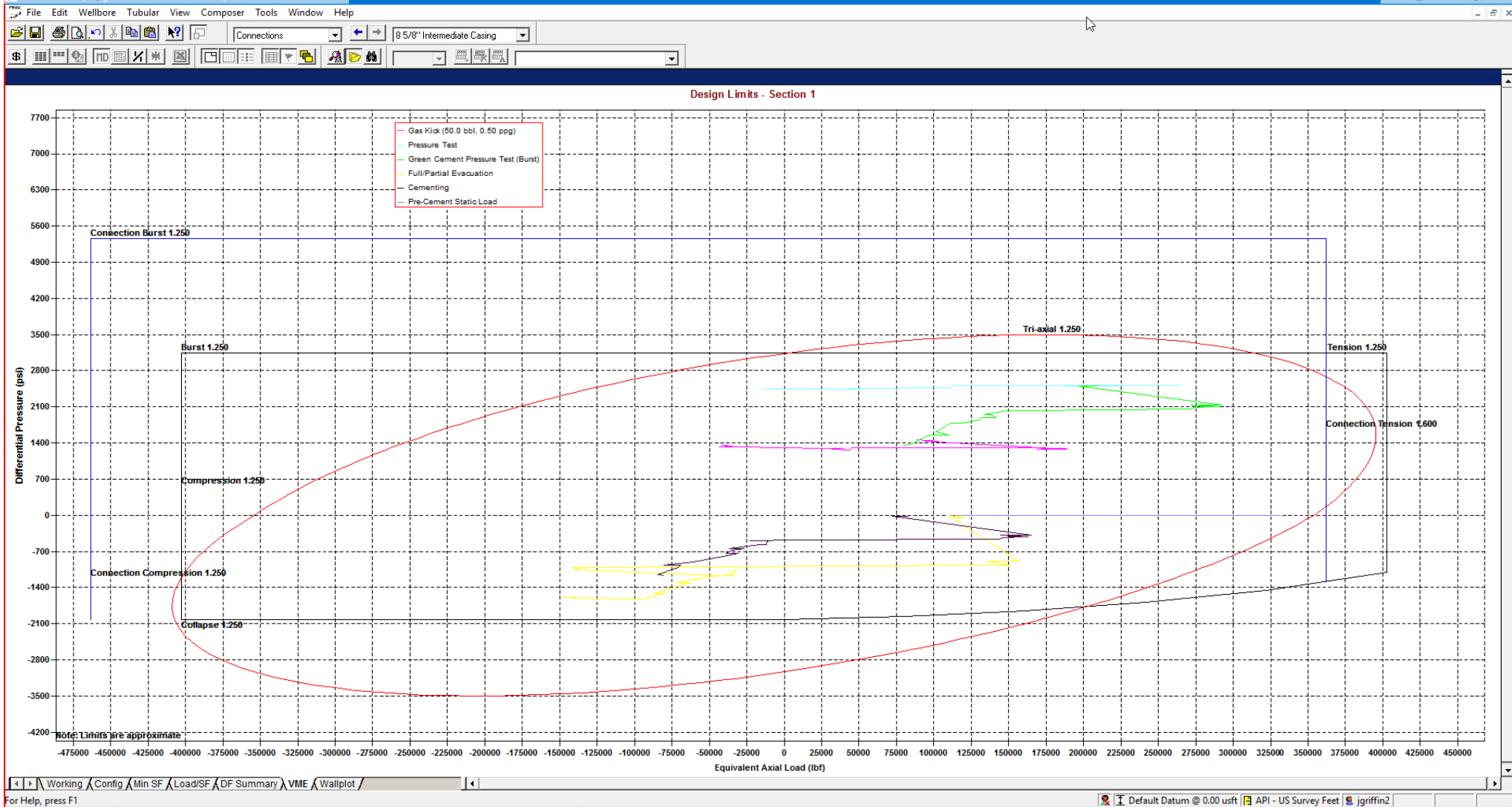

StressCheck - [String Summary - Shallow 3.0 Mile *]

String	OD/Weight/Grade	Connection	MD Interval (usft)	Drift Dia. (")	Minimum Safety Factor (Abs)				Design Cost (\$)	
					Burst	Collapse (V)	Axial	Triaxial		
1	Intermediate Casing	8 5/8", 32,000 ppg, J-55	BTC, J-55	0.0-5650.0	7.875 A	1.56	1.57	1.81 F	1.34	80,117
2										
3										
4	F Conn Fracture									
5	A Alternate Drift									
6	(V) Vector Collapse Safety Factor									
7										
Total = 80,117										

*Modelling done with 8-5/8" 32# Intermediate Casing. Passes all Burst, Collapse and Tensile design criteria.

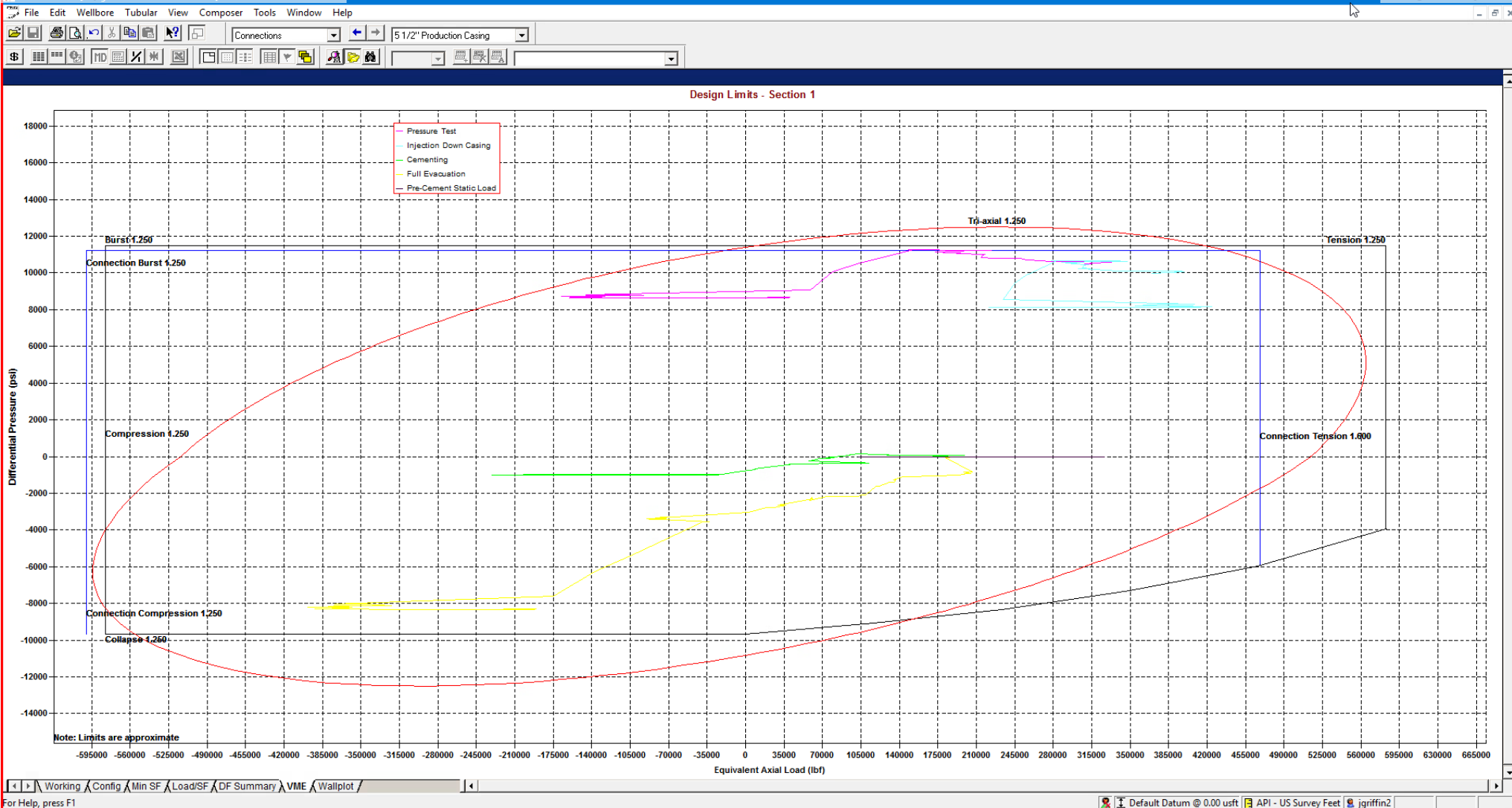

StressCheck - [String Summary - Shallow 3.0 Mile]

String	OD/Weight/Grade	Connection	MD Interval (usft)	Drift Dia. (")	Minimum Safety Factor (Abs)				Design Cost (\$)	
					Burst	Collapse (V)	Axial	Triaxial		
1	Production Casing	5 1/2", 20.000 ppf, P110 ICY	BTC, P110 ICY	0.0-28578.0	4.653	1.27	1.47	1.90 F	1.35	446,902
2										
3										
4	F Conn Fracture									
5	() Compression									
6	(V) Vector Collapse Safety Factor									
7										
Total = 446,902										

*Modelling done with 5-1/2" 20# Production Casing with a 125ksi Control Yield. Passes all Burst, Collapse and Tensile design criteria.



Shallow Design C

4. CASING PROGRAM

Hole Size	Interval MD		Interval TVD		Csg OD	Weight	Grade	Conn
	From (ft)	To (ft)	From (ft)	To (ft)				
16"	0	2,161	0	2,030	13-3/8"	54.5#	J-55	STC
11"	0	7,951	0	5,650	9-5/8"	40#	J-55	LTC
7-7/8"	0	29,353	0	12,000	6"	24.5#	P110-EC	VAM Sprint-SF

Hole will be full during casing run for well control and tensile SF factor. Casing will be kept at least half full during run for this design to meet BLM collapse SF requirement. External pressure will be reviewed prior to conducting casing pressure tests to ensure that 70% of the yield is not exceeded.

Variance is requested to waive the centralizer requirements for the 9-5/8" casing in the 11" hole size. An expansion additive will be utilized, in the cement slurry, for the entire length of the 11" hole interval to maximize cement bond and zonal isolation.

Variance is also requested to waive any centralizer requirements for the 6" casing in the 7-7/8" hole size. An expansion additive will be utilized, in the cement slurry, for the entire length of the 7-7/8" hole interval to maximize cement bond and zonal isolation.

EOG requests permission to allow deviation from the 0.422" annulus clearance requirement for the intermediate (salt) section from Title 43 CFR Part 3170 under the following conditions:

- The variance is not applicable within the Potash Boundaries or Capitan Reef areas.
- Operator takes responsibility to get casing to set point in the event that the clearance causes stuck pipe issues.

5. CEMENTING PROGRAM:

Depth	No. Sacks	Wt. ppg	Yld Ft3/sk	Slurry Description
2,030' 13-3/8"	570	13.5	1.73	Lead: Class C/H + 4.0% Bentonite Gel + 0.5% CaCl ₂ + 0.25 lb/sk Cello-Flake (TOC @ Surface)
	160	14.8	1.34	Tail: Class C/H + 0.6% FL-62 + 0.25 lb/sk Cello-Flake + 0.2% Sodium Metasilicate (TOC @ 1830')
8,050' 9-5/8"	760	12.7	2.22	Lead: Class C/H + 10% NaCl + 6% Bentonite Gel + 3% MagOx (TOC @ Surface)
	250	14.8	1.32	Tail: Class C/H + 10% NaCl + 3% MagOx (TOC @ 6360')
29,353' 6"	1000	14.8	1.32	Bradenhead squeeze: Class C/H + 3% Salt + 1% PreMag-M + 6% Bentonite Gel (TOC @ surface)
	2500	13.2	1.52	Tail: Class C/H + 5% NEX-020 + 0.2% NAC-102 + 0.15% NAS-725 + 0.5% NFL-549 + 0.2% NFP-703 + 1% NBE-737 + 0.3% NRT-241 (TOC @ Top of Brushy)



Shallow Design C

Proposed Wellbore

KB: 3558'

GL: 3533'

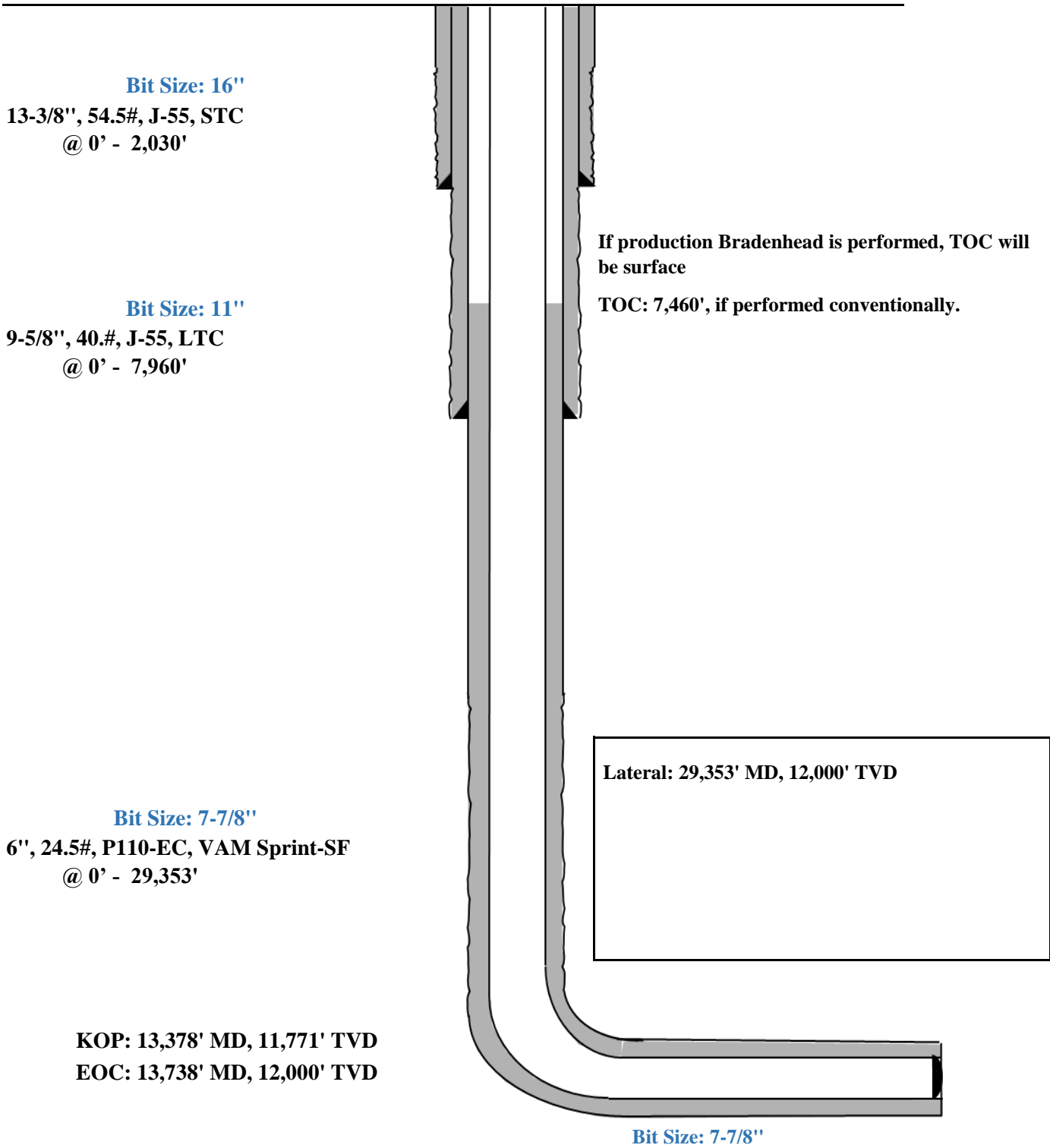

Triaxial Results	Depth (MD) (usft)	Axial Force (lbf)		Equivalent Axial Load (lbf)	Bending Stress at OD (psi)	Absolute Safety Factor				Temperature (°F)	Pressure (psi)		Add'l Pickup To Prevent Buck. (lbf)	Buckled Length (usft)
		Apparent (w/Bending)	Actual (w/o Bending)			Triaxial	Burst	Collapse (V)	Axial		Internal	External		
1	0	252987	228954	253140	2098.2	1.69	1.58	N/A	2.82 F	70.00	2500.00	0.00	N/A	N/A
2	100	247735	223702	248466	2098.2	1.69	1.58	N/A	2.88 F	71.10	2543.63	43.63		
3	100	234996	223701	235716	986.2	1.71	1.58	N/A	3.04 F	71.10	2543.64	43.64		
4	1700	341565	139667	352253	17627.2	1.53	1.57	N/A	2.09 F	88.70	3241.64	741.64		
5	1700	312979	139666	323488	15131.5	1.58	1.57	N/A	2.28 F	88.70	3241.65	741.65		
6	1850	336881	132027	348440	17885.2	1.51	1.57	N/A	2.12 F	90.29	3305.05	805.05		
7	1850	318549	132027	329984	16284.8	1.54	1.57	N/A	2.24 F	90.29	3305.06	805.06		
8	1950	320468	127243	332475	16869.9	1.52	1.57	N/A	2.23 F	91.30	3344.87	844.87		
9	1950	312802	127243	324756	16200.7	1.53	1.57	N/A	2.28 F	91.30	3344.87	844.87		
10	2050	307858	122773	320295	16159.3	1.52	1.57	N/A	2.32 F	92.23	3381.89	881.89		
11	2050	303560	122772	315965	15784.1	1.53	1.57	N/A	2.35 F	92.23	3381.89	881.89		
12	2300	151294	112633	163658	3375.4	1.71	1.57	N/A	4.72 F	94.35	3466.13	966.13		
13	2300	132741	112633	144956	1755.6	1.72	1.57	N/A	5.38 F	94.35	3466.14	966.14		
14	2370	129966	109858	142452	1755.6	1.72	1.57	N/A	5.49 F	94.94	3489.28	989.28		
15	2370	127909	107800	140922	1755.6	1.75	1.60	N/A	5.58 F	94.94	3489.29	1036.40		
16	2700	105515	94232	119785	985.1	1.75	1.60	N/A	6.77 F	97.73	3599.97	1152.35		
17	2700	111680	94231	126006	1523.4	1.75	1.60	N/A	6.39 F	97.73	3599.97	1152.35		
18	3100	110766	77783	126839	2879.6	1.71	1.60	N/A	6.44 F	101.11	3734.23	1293.00		
19	3100	97392	77783	113331	1712.1	1.73	1.60	N/A	7.33 F	101.11	3734.23	1293.01		
20	3700	71565	53303	89806	1594.4	1.70	1.61	N/A	9.97 F	106.15	3934.24	1502.54		
21	3700	60887	53302	79004	662.3	1.71	1.61	N/A	11.72 F	106.16	3934.25	1502.55		
22	4650	34671	14219	56495	1785.6	1.64	1.61	N/A	20.59 F	114.20	4253.37	1836.86		
23	4900	44595	4828	67626	3472.0	1.59	1.61	N/A	16.01 F	116.32	4337.37	1924.87		
24	4900	28975	4828	51775	2108.2	1.62	1.61	N/A	24.64 F	116.32	4337.38	1924.87		
25	5029	22103	34	45340	1926.8	1.61	1.61	N/A	32.30 F	117.40	4380.40	1969.94		
26	5029	22102	33	45339	1926.8	1.61	1.61	N/A	32.30 F	117.40	4380.41	1969.95		
27	5600	-45329	-21341	-20805	2094.3	1.57	1.62	N/A	(13.67)	122.23	4572.11	2170.78		
28	5650	-40465	-23210	-15657	1506.5	1.58	1.62	N/A	(15.31)	122.66	4588.87	2188.34		
29														
30		F	Conn Fracture											
31		()	Compression											
32		(V)	Vector Collapse Safety Factor											
33														

9-5/8" Intermediate Casing Pressure Test:
 Internal Profile based off Surface Pressure + Hydrostatic: 4589 psi
 External Profile based off Pore Pressure: 2188 psi

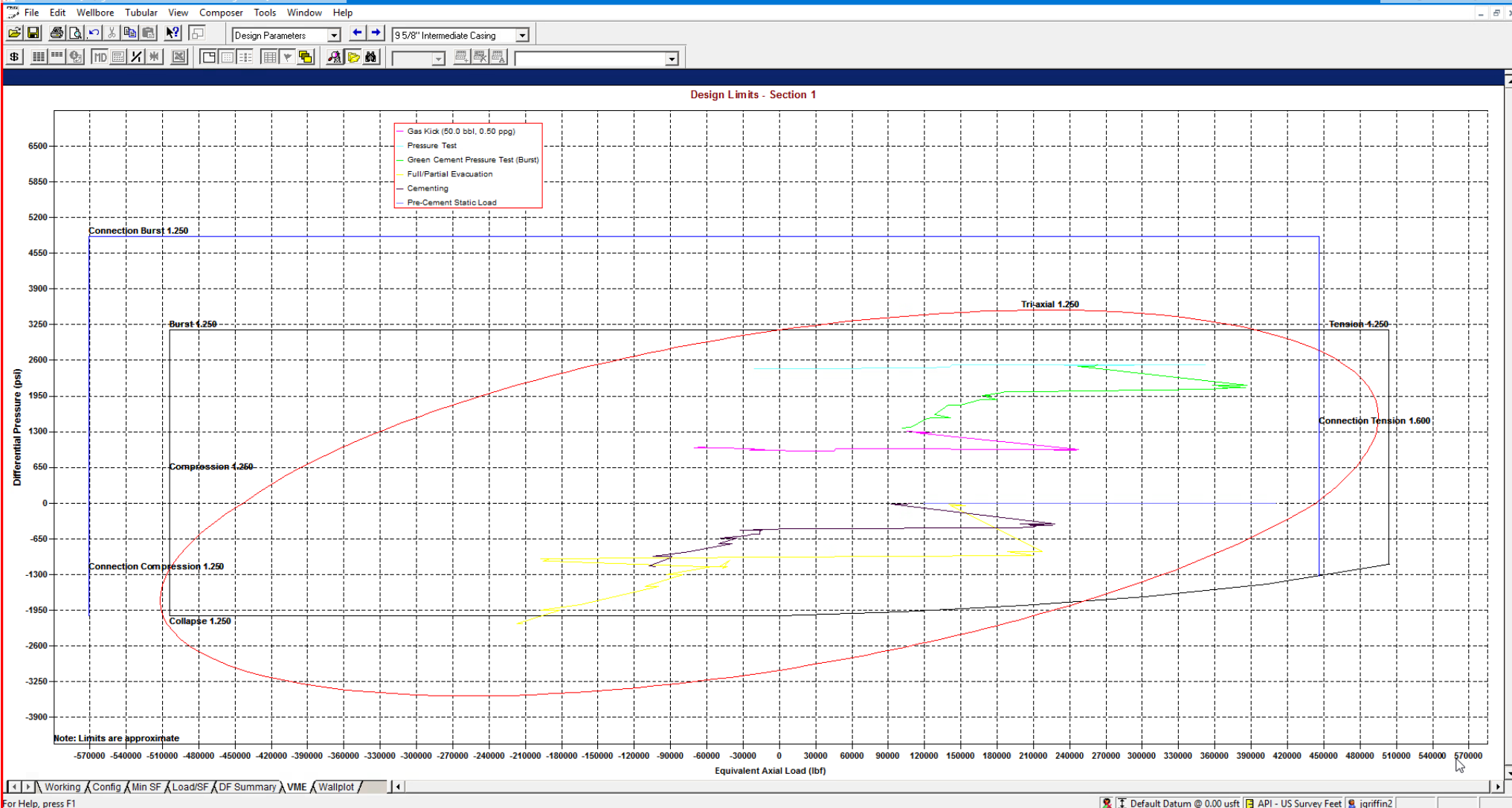

StressCheck - [String Summary - Shallow 3.0 Mile - Big Hole *]

String	OD/Weight/Grade	Connection	MD Interval (usft)	Drift Dia. (")	Minimum Safety Factor (Abs)				Design Cost (\$)
					Burst	Collapse (V)	Axial	Triaxial	
1	Intermediate Casing	BTC, J-55	0.0-5650.0	8.750 A	1.57	1.59	1.80 F	1.35	98,141
2									Total = 98,141
3									
4	F Conn Fracture								
5	A Alternate Drift								
6	(V) Vector Collapse Safety Factor								
7									

*Modelling done with 9-5/8" 40# Intermediate Casing. Passes all Burst, Collapse and Tensile design criteria.

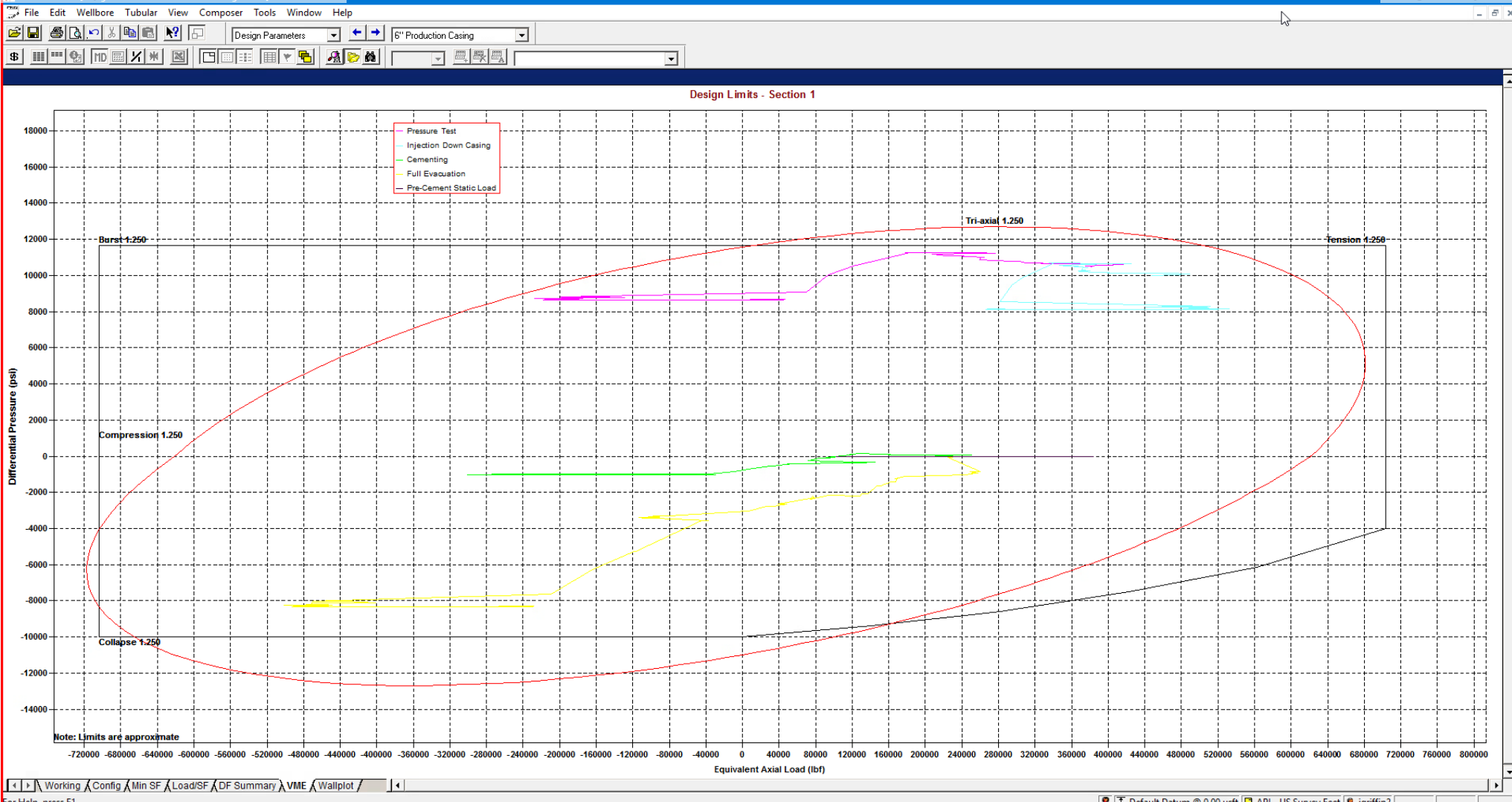

For Help, press F1

StressCheck - [String Summary - Shallow 3.0 Mile - Big Hole *]

String Summary

String	OD/Weight/Grade	Connection	MD Interval (usft)	Drift Dia. (")	Minimum Safety Factor (Abs)				Design Cost (\$)	
					Burst	Collapse (V)	Axial (1.75)	Triaxial		
1	Production Casing	6", 24.500 ppf, P110 ICY	BTC, P110 ICY	0.0-28578.0	5.075	1.29	1.52	(1.75)	1.37	541,493
2										
3										
4	() Compression									
5	(V) Vector Collapse Safety Factor									
6										
Total = 541,493										

*Modelling done with 6" Production Casing with a 125ksi Control Yield. Passes all Burst, Collapse and Tensile design criteria.



Shallow Design D

4. CASING PROGRAM

Hole Size	Interval MD		Interval TVD		Csg OD	Weight	Grade	Conn
	From (ft)	To (ft)	From (ft)	To (ft)				
16"	0	2,161	0	2,030	13-3/8"	54.5#	J-55	STC
11"	0	7,951	0	5,650	9-5/8"	40#	J-55	LTC
7-7/8"	0	13,278	0	11,671	6"	22.3#	P110-EC	DWC/C IS
6-3/4"	13,278	29,353	11,671	12,000	5-1/2"	20#	P110-EC	DWC/C IS MS

Hole will be full during casing run for well control and tensile SF factor. Casing will be kept at least half full during run for this design to meet BLM collapse SF requirement. External pressure will be reviewed prior to conducting casing pressure tests to ensure that 70% of the yield is not exceeded.

Variance is requested to waive the centralizer requirements for the 9-5/8" casing in the 11" hole size. An expansion additive will be utilized, in the cement slurry, for the entire length of the 11" hole interval to maximize cement bond and zonal isolation.

Variance is also requested to waive any centralizer requirements for the 6" and 5-1/2" casings in the 7-7/8" and 6-3/4" hole sizes. An expansion additive will be utilized in the cement slurry for the entire length of the 7-7/8" and 6-3/4" hole intervals to maximize cement bond and zonal isolation.

EOG requests permission to allow deviation from the 0.422" annulus clearance requirement for the intermediate (salt) section from Title 43 CFR Part 3170 under the following conditions:

- The variance is not applicable within the Potash Boundaries or Capitan Reef areas.
- Operator takes responsibility to get casing to set point in the event that the clearance causes stuck pipe issues.

5. CEMENTING PROGRAM:

Depth	No. Sacks	Wt. ppg	Yld Ft3/sk	Slurry Description
2,030' 13-3/8"	570	13.5	1.73	Lead: Class C/H + 4.0% Bentonite Gel + 0.5% CaCl ₂ + 0.25 lb/sk Cello-Flake (TOC @ Surface)
	160	14.8	1.34	Tail: Class C/H + 0.6% FL-62 + 0.25 lb/sk Cello-Flake + 0.2% Sodium Metasilicate (TOC @ 1830')
8,050' 9-5/8"	760	12.7	2.22	Lead: Class C/H + 10% NaCl + 6% Bentonite Gel + 3% MagOx (TOC @ Surface)
	250	14.8	1.32	Tail: Class C/H + 10% NaCl + 3% MagOx (TOC @ 6360')
29,353' 6"	1000	14.8	1.32	Bradenhead squeeze: Class C/H + 3% Salt + 1% PreMag-M + 6% Bentonite Gel (TOC @ surface)
	2500	13.2	1.52	Tail: Class C/H + 5% NEX-020 + 0.2% NAC-102 + 0.15% NAS-725 + 0.5% NFL-549 + 0.2% NFP-703 + 1% NBE-737 + 0.3% NRT-241 (TOC @ Top of Brushy)



Shallow Design D

Proposed Wellbore

KB: 3558'

GL: 3533'

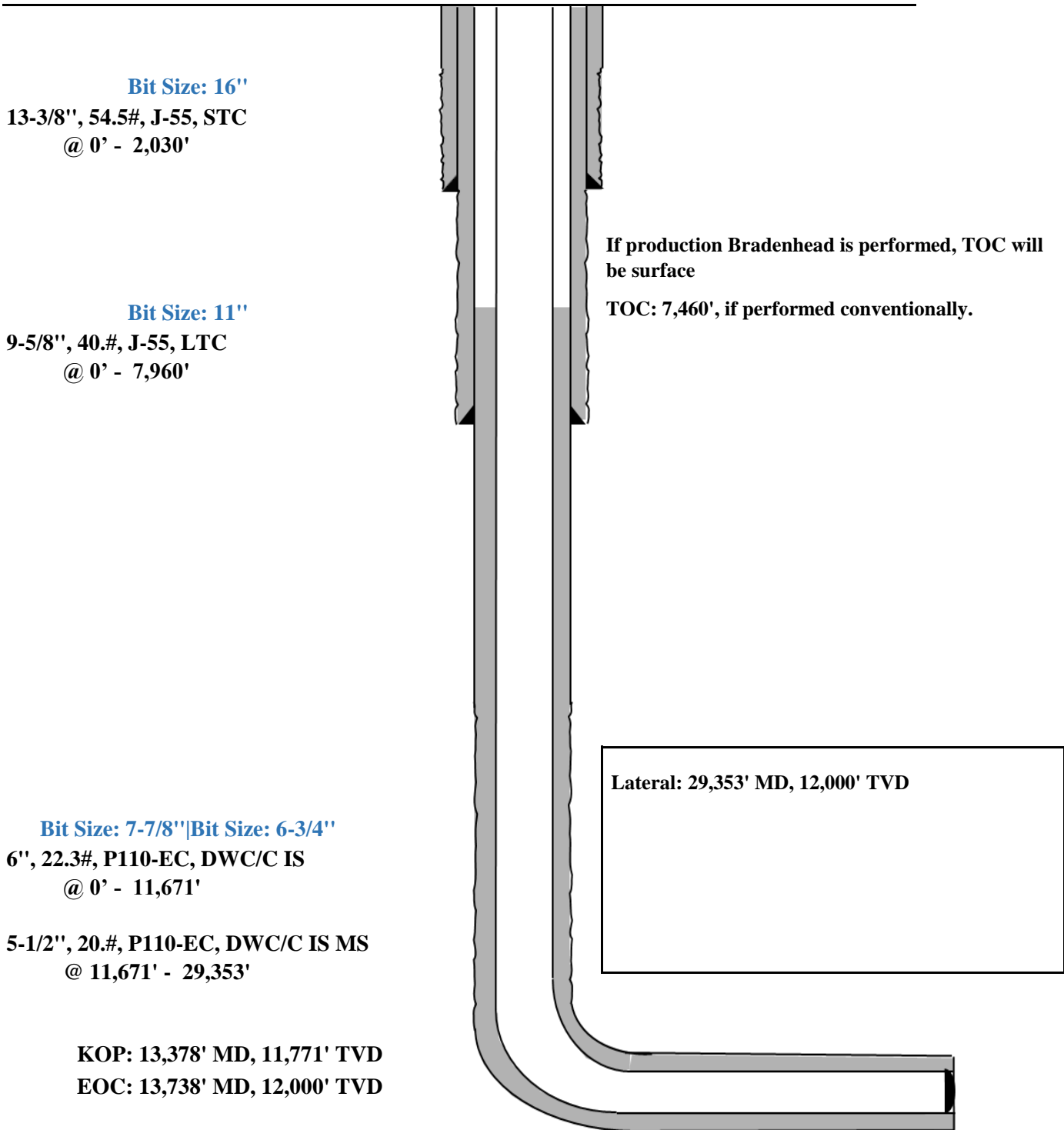

Bit Size: 16"

13-3/8", 54.5#, J-55, STC
@ 0' - 2,030'

Bit Size: 11"

9-5/8", 40.#, J-55, LTC
@ 0' - 7,960'

Bit Size: 7-7/8" | Bit Size: 6-3/4"

6", 22.3#, P110-EC, DWC/C IS
@ 0' - 11,671'

5-1/2", 20.#, P110-EC, DWC/C IS MS
@ 11,671' - 29,353'

KOP: 13,378' MD, 11,771' TVD
EOC: 13,738' MD, 12,000' TVD

If production Bradenhead is performed, TOC will be surface

TOC: 7,460', if performed conventionally.

Lateral: 29,353' MD, 12,000' TVD

Triaxial Results	Depth (MD) (usft)	Axial Force (lbf)		Equivalent Axial Load (lbf)	Bending Stress at OD (psi)	Absolute Safety Factor				Temperature (°F)	Pressure (psi)		Add'l Pickup To Prevent Buck. (lbf)	Buckled Length (usft)
		Apparent (w/Bending)	Actual (w/o Bending)			Triaxial	Burst	Collapse (V)	Axial		Internal	External		
1	0	252987	228954	253140	2098.2	1.69	1.58	N/A	2.82 F	70.00	2500.00	0.00	N/A	N/A
2	100	247735	223702	248466	2098.2	1.69	1.58	N/A	2.88 F	71.10	2543.63	43.63		
3	100	234996	223701	235716	986.2	1.71	1.58	N/A	3.04 F	71.10	2543.64	43.64		
4	1700	341565	139667	352253	17627.2	1.53	1.57	N/A	2.09 F	88.70	3241.64	741.64		
5	1700	312979	139666	323488	15131.5	1.58	1.57	N/A	2.28 F	88.70	3241.65	741.65		
6	1850	336881	132027	348440	17885.2	1.51	1.57	N/A	2.12 F	90.29	3305.05	805.05		
7	1850	318549	132027	329984	16284.8	1.54	1.57	N/A	2.24 F	90.29	3305.06	805.06		
8	1950	320468	127243	332475	16869.9	1.52	1.57	N/A	2.23 F	91.30	3344.87	844.87		
9	1950	312802	127243	324756	16200.7	1.53	1.57	N/A	2.28 F	91.30	3344.87	844.87		
10	2050	307858	122773	320295	16159.3	1.52	1.57	N/A	2.32 F	92.23	3381.89	881.89		
11	2050	303560	122772	315965	15784.1	1.53	1.57	N/A	2.35 F	92.23	3381.89	881.89		
12	2300	151294	112633	163658	3375.4	1.71	1.57	N/A	4.72 F	94.35	3466.13	966.13		
13	2300	132741	112633	144956	1755.6	1.72	1.57	N/A	5.38 F	94.35	3466.14	966.14		
14	2370	129966	109858	142452	1755.6	1.72	1.57	N/A	5.49 F	94.94	3489.28	989.28		
15	2370	127909	107800	140922	1755.6	1.75	1.60	N/A	5.58 F	94.94	3489.29	1036.40		
16	2700	105515	94232	119785	985.1	1.75	1.60	N/A	6.77 F	97.73	3599.97	1152.35		
17	2700	111680	94231	126006	1523.4	1.75	1.60	N/A	6.39 F	97.73	3599.97	1152.35		
18	3100	110766	77783	126839	2879.6	1.71	1.60	N/A	6.44 F	101.11	3734.23	1293.00		
19	3100	97392	77783	113331	1712.1	1.73	1.60	N/A	7.33 F	101.11	3734.23	1293.01		
20	3700	71565	53303	89806	1594.4	1.70	1.61	N/A	9.97 F	106.15	3934.24	1502.54		
21	3700	60887	53302	79004	662.3	1.71	1.61	N/A	11.72 F	106.16	3934.25	1502.55		
22	4650	34671	14219	56495	1785.6	1.64	1.61	N/A	20.59 F	114.20	4253.37	1836.86		
23	4900	44595	4828	67626	3472.0	1.59	1.61	N/A	16.01 F	116.32	4337.37	1924.87		
24	4900	28975	4828	51775	2108.2	1.62	1.61	N/A	24.64 F	116.32	4337.38	1924.87		
25	5029	22103	34	45340	1926.8	1.61	1.61	N/A	32.30 F	117.40	4380.40	1969.94		
26	5029	22102	33	45339	1926.8	1.61	1.61	N/A	32.30 F	117.40	4380.41	1969.95		
27	5600	-45329	-21341	-20805	2094.3	1.57	1.62	N/A	(13.67)	122.23	4572.11	2170.78		
28	5650	-40465	-23210	-15657	1506.5	1.58	1.62	N/A	(15.31)	122.66	4588.87	2188.34		
29														
30		F	Conn Fracture											
31		()	Compression											
32		(V)	Vector Collapse Safety Factor											
33														

9-5/8" Intermediate Casing Pressure Test:
 Internal Profile based off Surface Pressure + Hydrostatic: 4589 psi
 External Profile based off Pore Pressure: 2188 psi

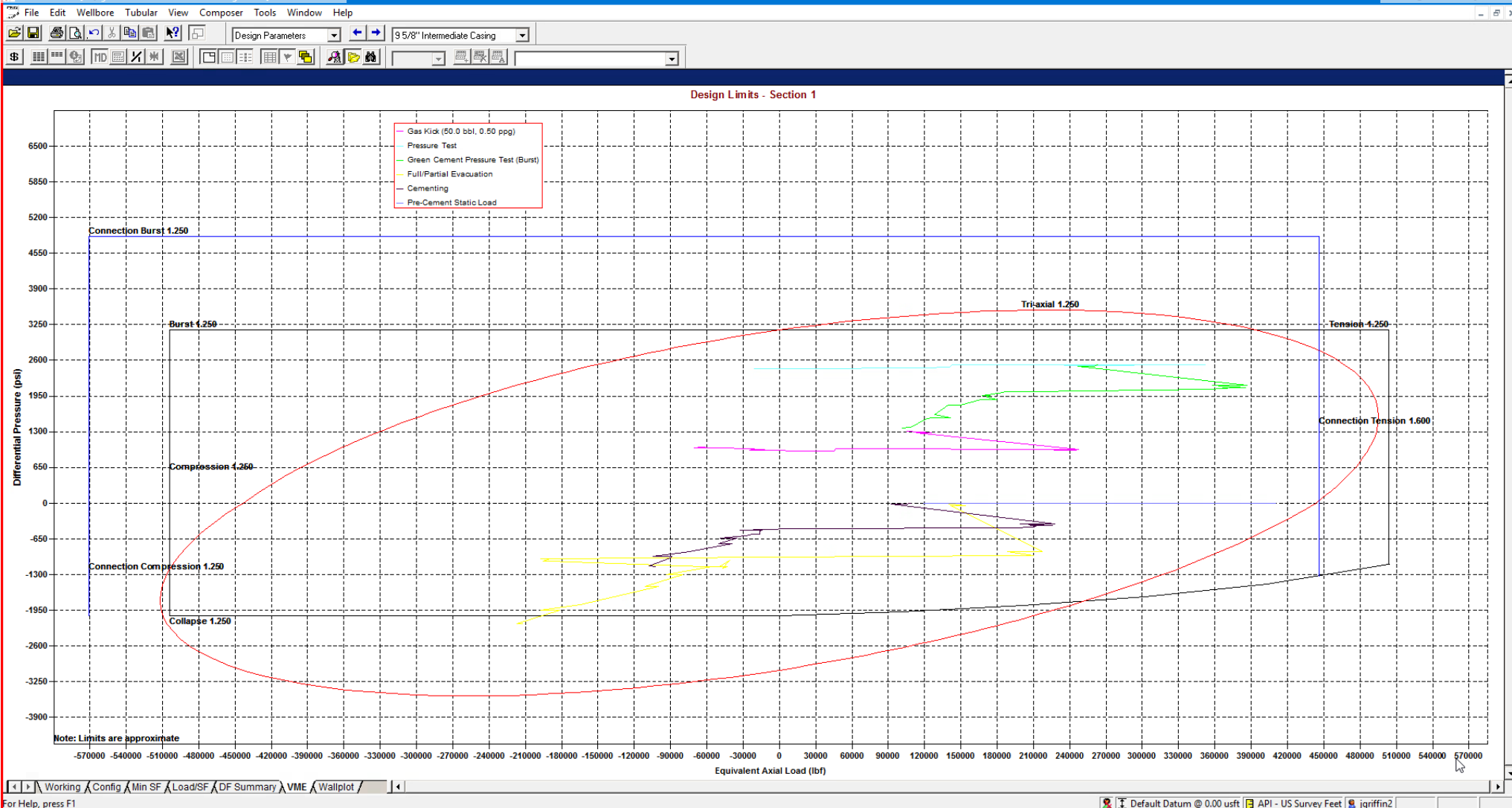

StressCheck - [String Summary - Shallow 3.0 Mile - Big Hole *]

String Summary

String	OD/Weight/Grade	Connection	MD Interval (usft)	Drift Dia. (")	Minimum Safety Factor (Abs)				Design Cost (\$)
					Burst	Collapse (V)	Axial	Triaxial	
1 Intermediate Casing	9 5/8", 40.000 ppf, J-55	BTC, J-55	0.0-5650.0	8.750 A	1.57	1.59	1.80 F	1.35	98,141
2									Total = 98,141
3									
4 F Conn Fracture									
5 A Alternate Drift									
6 (V) Vector Collapse Safety Factor									
7									

*Modelling done with 9-5/8" 40# Intermediate Casing. Passes all Burst, Collapse and Tensile design criteria.

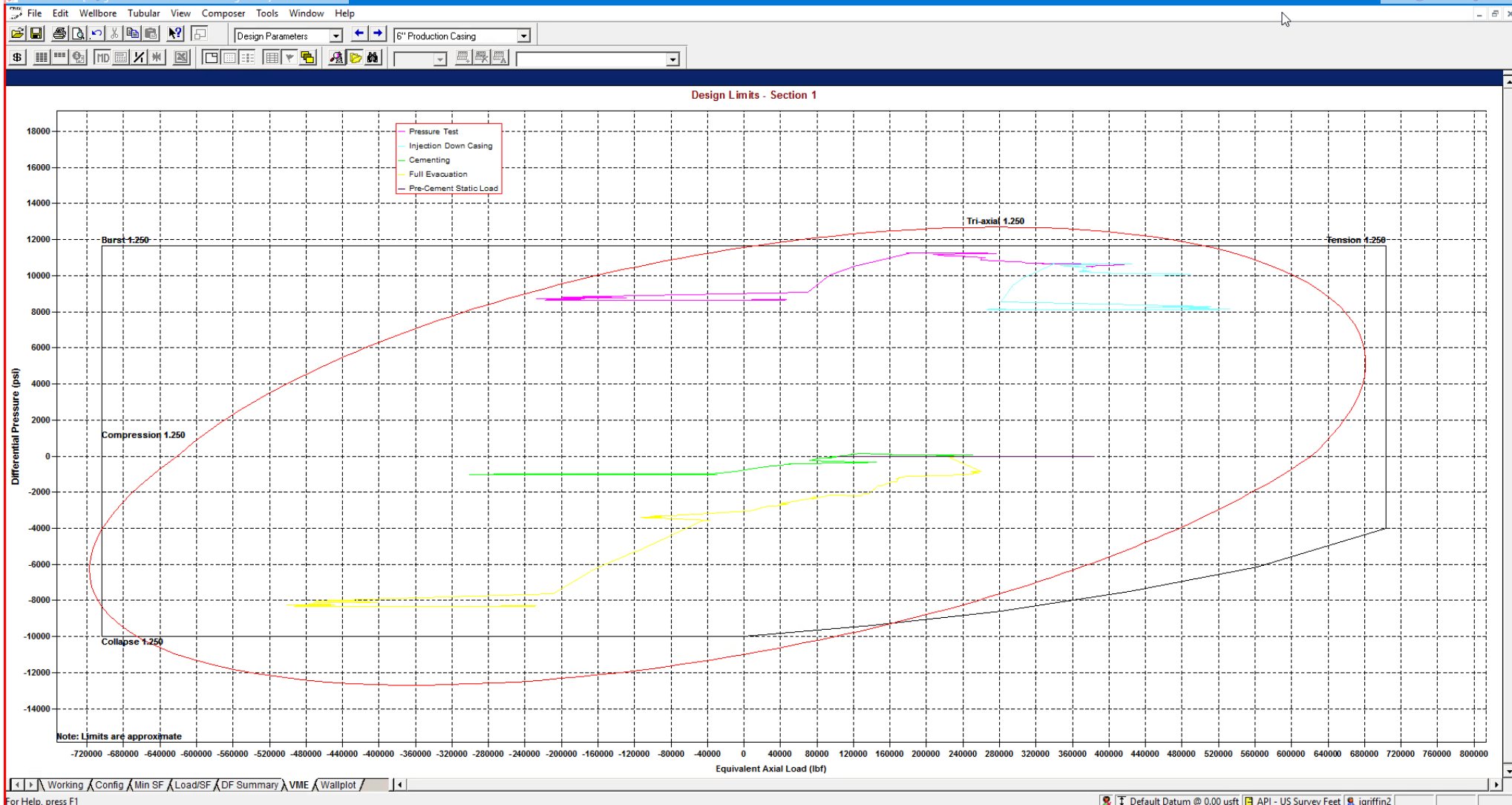

For Help, press F1

Working \Config \Min SF \Load/SF \DF Summary \VME \Wallplot

StressCheck - [String Summary - Shallow 3.0 Mile - Big Hole *]

String	OD/Weight/Grade	Connection	MD Interval (usft)	Drift Dia. (")	Minimum Safety Factor (Abs)				Design Cost (\$)	
					Burst	Collapse (V)	Axial (1.75)	Triaxial		
1	Production Casing	6", 24.500 ppf, P110 ICY	BTC, P110 ICY	0.0-28578.0	5.075	1.29	1.52	(1.75)	1.37	541,493
2										
3										
4	() Compression									
5	(V) Vector Collapse Safety Factor									
6										
Total = 541,493										

*Modelling done with 6" Production Casing with a 125ksi Control Yield. Passes all Burst, Collapse and Tensile design criteria.

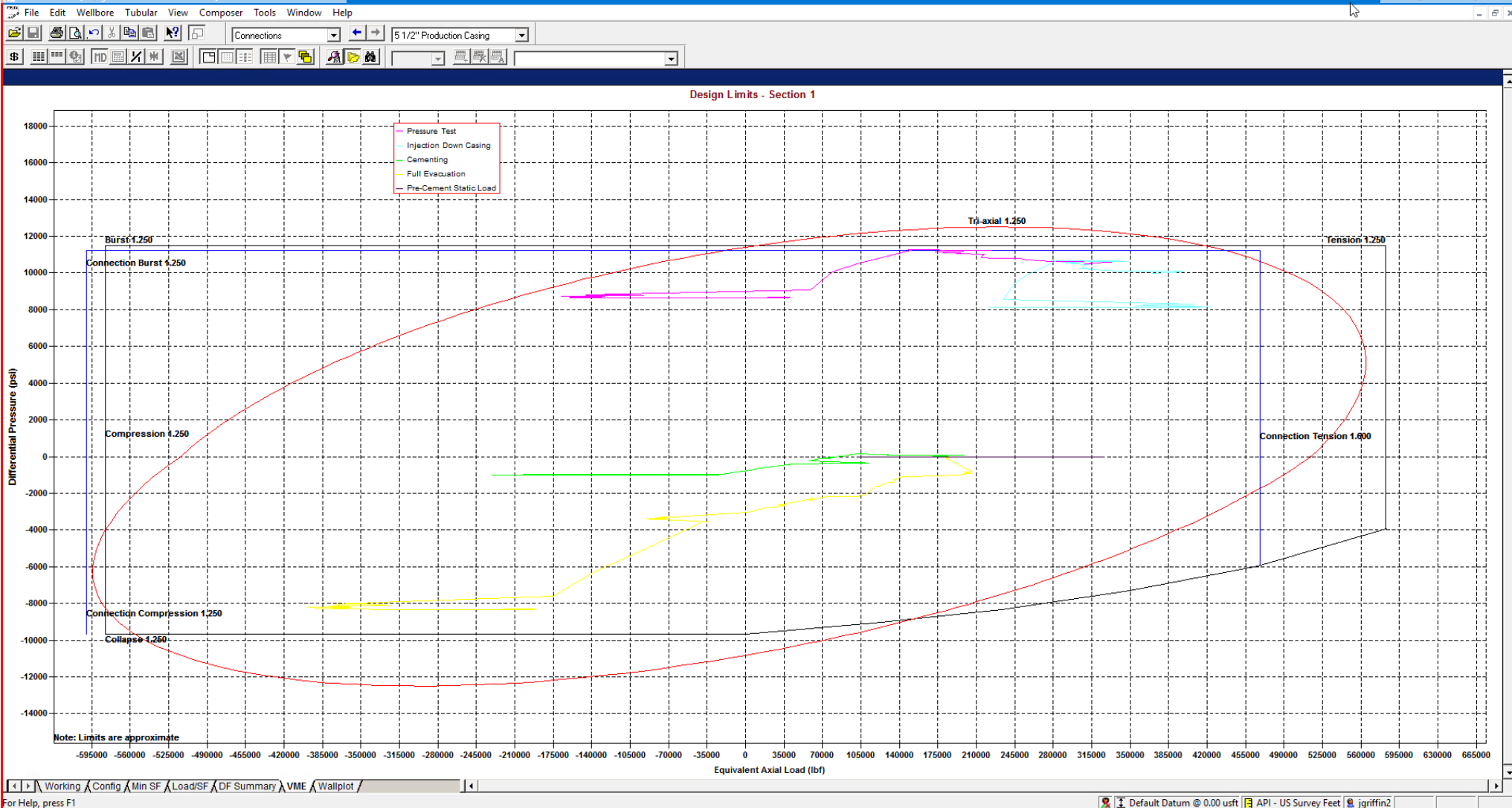

StressCheck - [String Summary - Shallow 3.0 Mile]

String	OD/Weight/Grade	Connection	MD Interval (usft)	Drift Dia. (")	Minimum Safety Factor (Abs)				Design Cost (\$)	
					Burst	Collapse (V)	Axial	Triaxial		
1	Production Casing	5 1/2", 20.000 ppf, P110 ICY	BTC, P110 ICY	0.0-28578.0	4.653	1.27	1.47	1.90 F	1.35	446,902
2										
3										
4	F Conn Fracture									
5	() Compression									
6	(V) Vector Collapse Safety Factor									
7										
Total = 446,902										

*Modelling done with 5-1/2" 20# Production Casing with a 125ksi Control Yield. Passes all Burst, Collapse and Tensile design criteria.



Shallow Casing Design E

1. CASING PROGRAM

Hole Size	Interval MD		Interval TVD		Csg OD	Weight	Grade	Conn
	From (ft)	To (ft)	From (ft)	To (ft)				
13"	0	2,025	0	2,025	10-3/4"	40.5#	J-55	STC
9-7/8"	0	7,793	0	5,645	8-5/8"	32#	J-55	BTC-SC
7-7/8"	0	12,626	0	10,896	6"	24.5#	P110-EC	VAM Sprint-TC
6-3/4"	12,626	28,578	10,896	11,225	5-1/2"	20#	P110-EC	VAM Sprint SF

**For highlighted rows above, variance is requested to run entire string of either 6" or 5-1/2" casing string above due to availability.

Hole will be full during casing run for well control and tensile SF factor. Casing will be kept at least half full during run for this design to meet BLM collapse SF requirement. External pressure will be reviewed prior to conducting casing pressure tests to ensure that 70% of the yield is not exceeded.

Variance is requested to waive the centralizer requirements for the 8-5/8" casing in the 9-7/8" hole size. An expansion additive will be utilized, in the cement slurry, for the entire length of the 9-7/8" hole interval to maximize cement bond and zonal isolation.

Variance is also requested to waive any centralizer requirements for the 6" and 5-1/2" casings in the 7-7/8" and 6-3/4" hole sizes. An expansion additive will be utilized in the cement slurry for the entire length of the 7-7/8" and 6-3/4" hole intervals to maximize cement bond and zonal isolation.

EOG requests permission to allow deviation from the 0.422" annulus clearance requirement for the intermediate (salt) section from Title 43 CFR Part 3170 under the following conditions:

- The variance is not applicable within the Potash Boundaries or Capitan Reef areas.
- Operator takes responsibility to get casing to set point in the event that the clearance causes stuck pipe issues.

2. CEMENTING PROGRAM:

Depth	No. Sacks	Wt. ppg	Yld Ft3/sk	Slurry Description
2,030' 10-3/4"	450	13.5	1.73	Lead: Class C/H + 4.0% Bentonite Gel + 0.5% CaCl ₂ + 0.25 lb/sk Cello-Flake (TOC @ Surface)
	120	14.8	1.34	Tail: Class C/H + 0.6% FL-62 + 0.25 lb/sk Cello-Flake + 0.2% Sodium Metasilicate (TOC @ 1830')
7,890' 8-5/8"	460	12.7	2.22	Lead: Class C/H + 10% NaCl + 6% Bentonite Gel + 3% MagOx (TOC @ Surface)
	210	14.8	1.32	Tail: Class C/H + 10% NaCl + 3% MagOx (TOC @ 6234')
28,578' 6"	1000	14.8	1.32	Bradenhead squeeze: Class C/H + 3% Salt + 1% PreMag-M + 6% Bentonite Gel (TOC @ surface)
	2410	13.2	1.52	Tail: Class C/H + 5% NEX-020 + 0.2% NAC-102 + 0.15% NAS-725 + 0.5% NFL-549 + 0.2% NFP-703 + 1% NBE-737 + 0.3% NRT-241 (TOC @ 8140')



Shallow Casing Design E

Proposed Wellbore

KB: 3558'

GL: 3533'

API: 30-025-*****

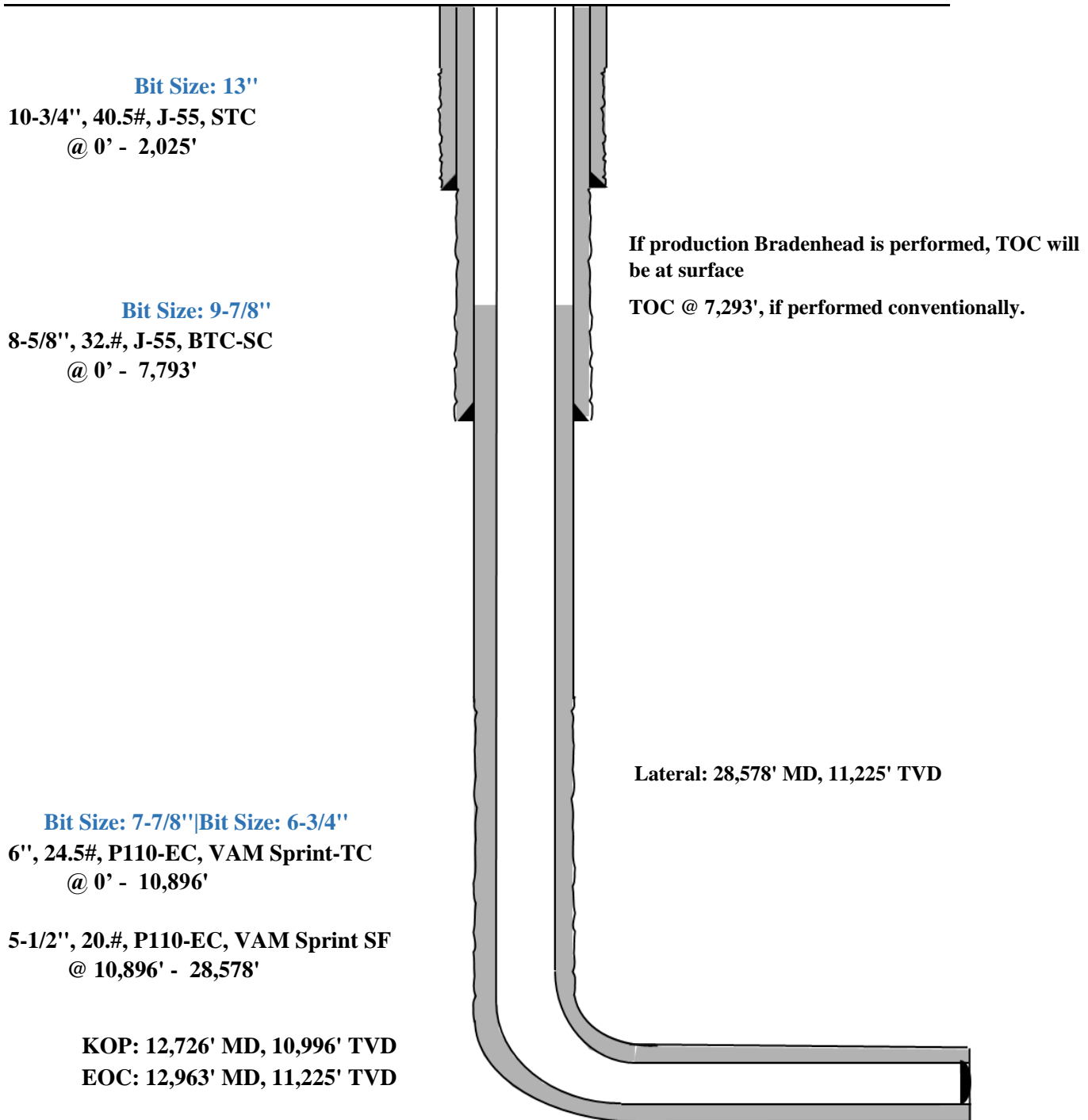

StressCheck - [Triaxial Results - Shallow 3.0 Mile *]

File Edit Wellbore Tubular View Composer Tools Window Help

Burst Design 8 5/8" Intermediate Casing Pressure Test

Triaxial Results

	Depth (MD) (usft)	Axial Force (lbf)		Equivalent Axial Load (lbf)	Bending Stress at OD (psi)	Absolute Safety Factor				Temperature (°F)	Pressure (psi)		Addtl Pickup To Prevent Buck. (lbf)	Buckled Length (usft)
		Apparent (w/Bending)	Actual (w/o Bending)			Triaxial	Burst	Collapse (V)	Axial		Internal	External		
1	0	200426	183224	200546	1880.2	1.68	1.57	N/A	2.89 F	70.00	2500.00	0.00	N/A	N/A
2	100	196229	179028	196812	1880.2	1.69	1.57	N/A	2.95 F	71.10	2543.63	43.63		
3	100	187111	179027	187686	883.7	1.70	1.57	N/A	3.10 F	71.10	2543.64	43.64		
4	1700	256401	111891	264835	15795.8	1.56	1.56	N/A	2.26 F	88.70	3241.64	741.64		
5	1700	235940	111891	244247	13559.4	1.60	1.56	N/A	2.45 F	88.70	3241.65	741.65		
6	1850	252413	105788	261533	16027.0	1.54	1.56	N/A	2.29 F	90.29	3305.05	805.05		
7	1850	239292	105787	248323	14592.9	1.56	1.56	N/A	2.42 F	90.29	3305.06	805.06		
8	1950	240267	101966	249748	15117.2	1.54	1.56	N/A	2.41 F	91.30	3344.87	844.87		
9	1950	234781	101965	244223	14517.5	1.56	1.56	N/A	2.47 F	91.30	3344.87	844.87		
10	2050	230871	98395	240694	14480.4	1.55	1.56	N/A	2.51 F	92.23	3381.89	881.89		
11	2050	227794	98394	237594	14144.2	1.55	1.56	N/A	2.54 F	92.23	3381.89	881.89		
12	2300	117966	90294	127818	3024.7	1.70	1.56	N/A	4.91 F	94.35	3466.13	966.13		
13	2300	104686	90293	114432	1573.2	1.71	1.56	N/A	5.53 F	94.35	3466.14	966.14		
14	2370	102469	88077	112431	1573.2	1.71	1.56	N/A	5.65 F	94.94	3489.28	989.28		
15	2370	100817	86424	111200	1573.2	1.75	1.59	N/A	5.75 F	94.94	3489.29	1036.40		
16	2700	83660	75583	95052	882.8	1.74	1.59	N/A	6.92 F	97.73	3599.97	1152.35		
17	2700	88072	75583	99504	1365.1	1.74	1.59	N/A	6.58 F	97.73	3599.97	1152.35		
18	3100	86049	62442	98863	2580.4	1.71	1.59	N/A	6.73 F	101.11	3734.23	1293.00		
19	3100	76477	62441	89195	1534.2	1.72	1.59	N/A	7.57 F	101.11	3734.23	1293.01		
20	3700	55953	42882	70509	1428.8	1.69	1.60	N/A	10.35 F	106.15	3934.24	1502.54		
21	3700	48311	42881	62778	593.5	1.71	1.60	N/A	11.99 F	106.16	3934.25	1502.55		
22	4000	41458	33043	56865	919.9	1.69	1.60	N/A	13.97 F	108.69	4034.82	1607.91		
23	4650	26293	11655	43706	1600.1	1.63	1.60	N/A	22.03 F	114.20	4253.37	1836.86		
24	4900	32619	4156	50970	3111.2	1.59	1.60	N/A	17.76 F	116.32	4337.37	1924.87		
25	4900	21439	4155	39625	1889.2	1.61	1.60	N/A	27.02 F	116.32	4337.38	1924.87		
26	5039	15822	26	34389	1726.6	1.61	1.61	N/A	36.61 F	117.49	4383.77	1973.48		
27	5039	15822	26	34388	1726.6	1.61	1.61	N/A	36.61 F	117.49	4383.78	1973.49		
28	5600	-33912	-16743	-14286	1876.7	1.57	1.61	N/A	(14.60)	122.23	4572.11	2170.78		
29	5650	-30585	-18235	-10742	1350.0	1.58	1.61	N/A	(16.18)	122.66	4588.87	2188.34		
30														
31		F	Conn Fracture											
32		(Compression											
33		(V)	Vector Collapse Safety Factor											
34														

Working Config Min SF Load/SF DF Summary VME Wallplot

For Help, press F1

Default Datum @ 0.00 usft API - US Survey Feet jgriffin2

8-5/8" Intermediate Casing Pressure Test:
 Internal Profile based off Surface Pressure + Hydrostatic: 4589 psi
 External Profile based off Pore Pressure: 2188 psi

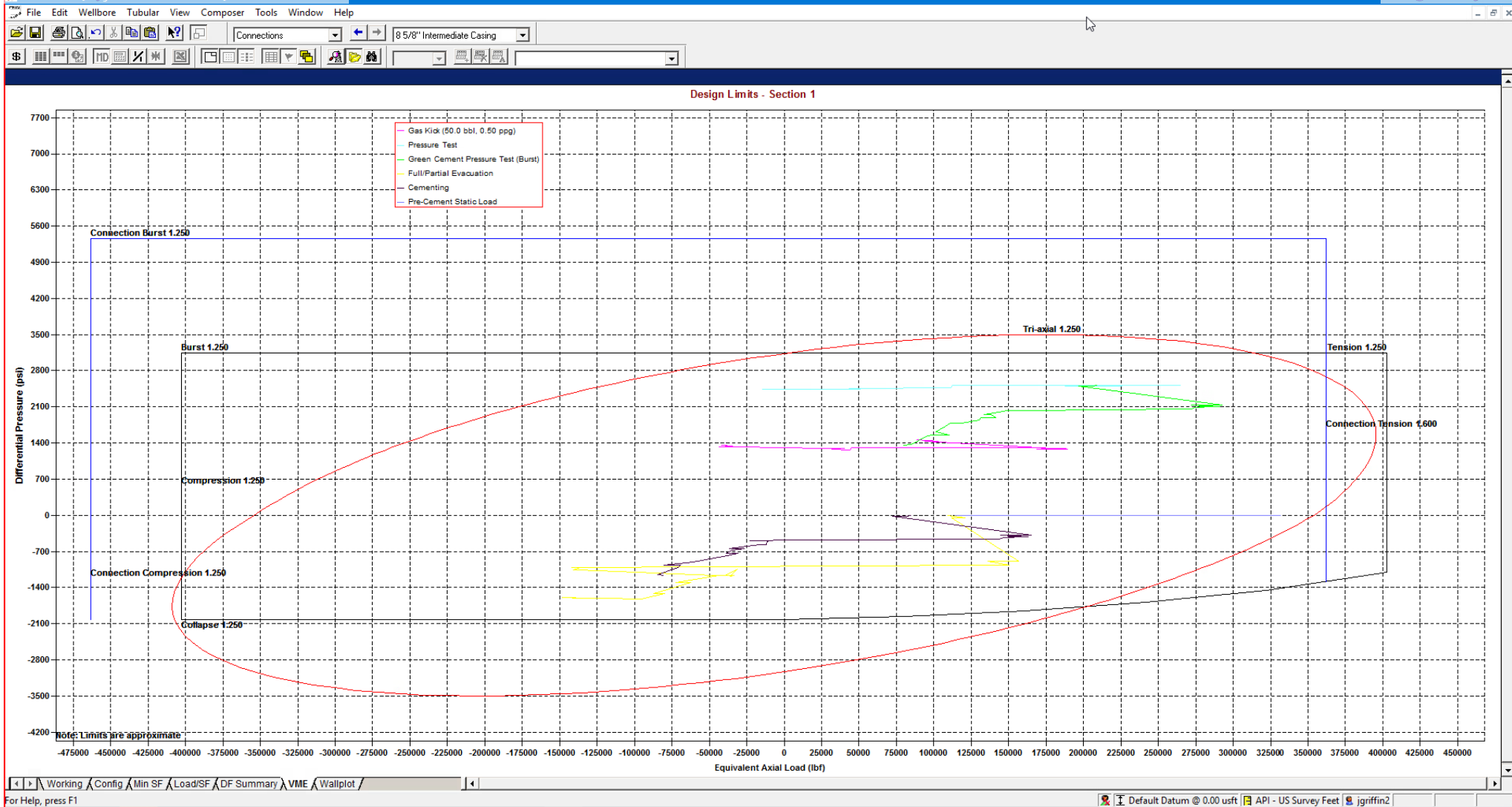

StressCheck - [String Summary - Shallow 3.0 Mile]

String	OD/Weight/Grade	Connection	MD Interval (usft)	Drift Dia. (")	Minimum Safety Factor (Abs)				Design Cost (\$)	
					Burst	Collapse (V)	Axial	Triaxial		
1	Intermediate Casing	8 5/8", 32,000 ppf, J-55	BTC, J-55	0.0-5650.0	7.875 A	1.56	1.57	1.81 F	1.34	80,117
2										Total = 80,117
3										
4	F Conn Fracture									
5	A Alternate Drift									
6	(V) Vector Collapse Safety Factor									
7										

*Modelling done with 8-5/8" 32# Intermediate Casing. Passes all Burst, Collapse and Tensile design criteria.

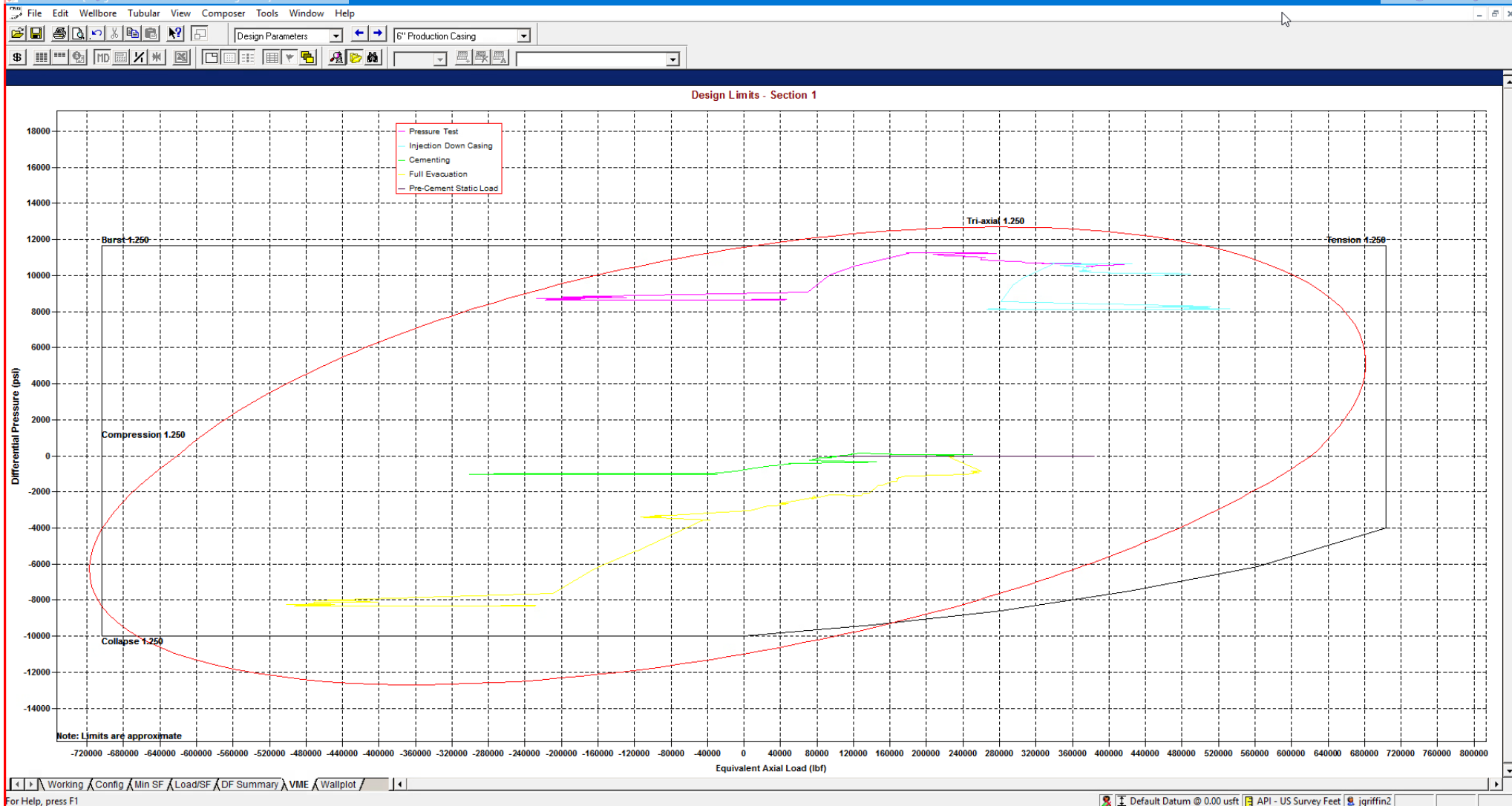

String Summary

String	OD/Weight/Grade	Connection	MD Interval (usft)	Drift Dia. (")	Minimum Safety Factor (Abs)				Design Cost (\$)	
					Burst	Collapse (V)	Axial (1.75)	Triaxial		
1	Production Casing	6", 24.500 ppf, P110 ICY	BTC, P110 ICY	0.0-28578.0	5.075	1.29	1.52	(1.75)	1.37	541,493
2										
3										
4	() Compression									
5	(V) Vector Collapse Safety Factor									
6										
Total = 541,493										

*Modelling done with 6" Production Casing with a 125ksi Control Yield. Passes all Burst, Collapse and Tensile design criteria.

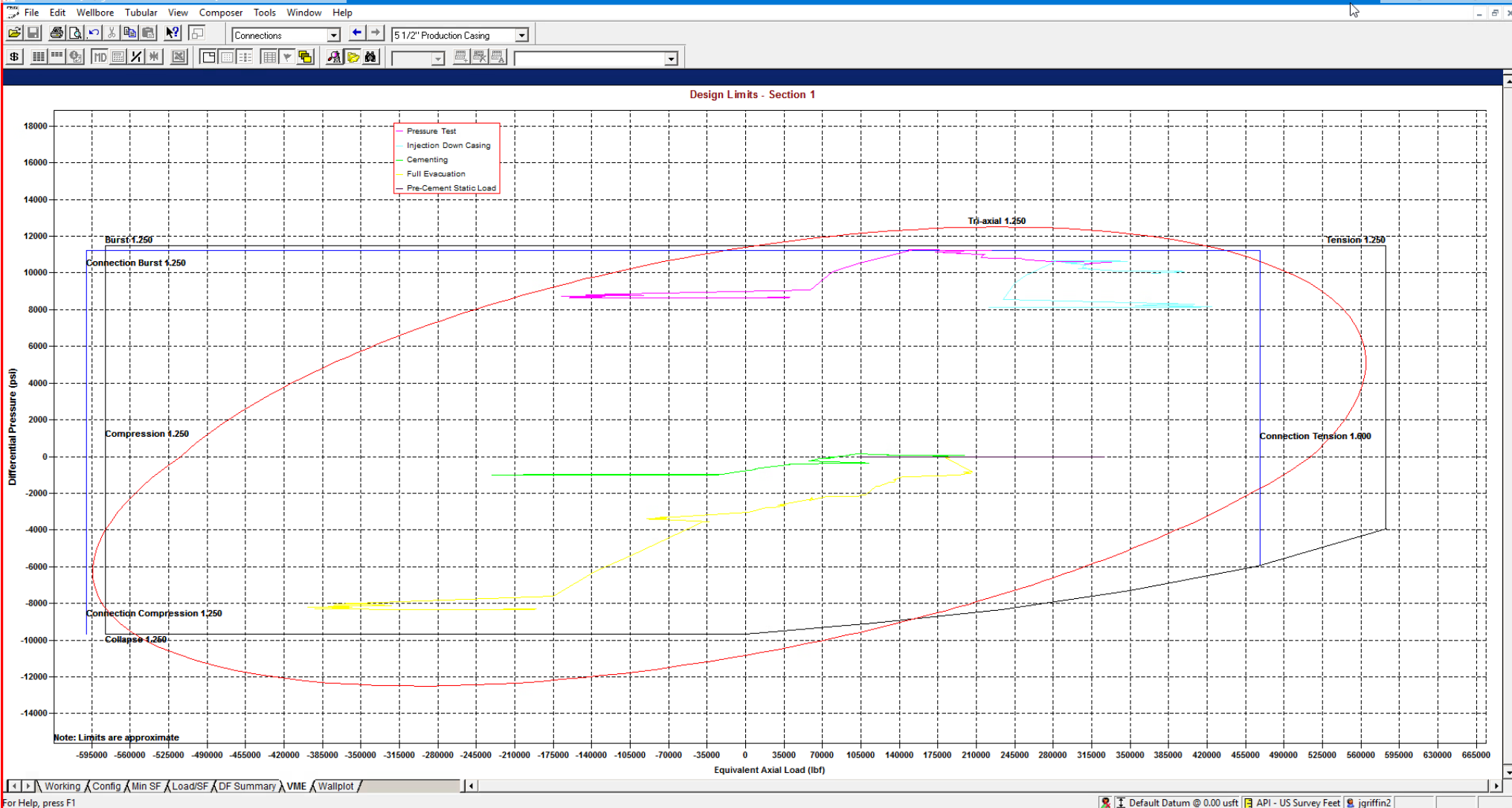

StressCheck - [String Summary - Shallow 3.0 Mile]

String	OD/Weight/Grade	Connection	MD Interval (usft)	Drift Dia. (")	Minimum Safety Factor (Abs)				Design Cost (\$)	
					Burst	Collapse (V)	Axial	Triaxial		
1	Production Casing	5 1/2", 20.000 ppf, P110 ICY	BTC, P110 ICY	0.0-28578.0	4.653	1.27	1.47	1.90 F	1.35	446,902
2										
3										
4	F Conn Fracture									
5	() Compression									
6	(V) Vector Collapse Safety Factor									
7										
Total = 446,902										

*Modelling done with 5-1/2" 20# Production Casing with a 125ksi Control Yield. Passes all Burst, Collapse and Tensile design criteria.



Shallow Casing Design 501H

Additive	Purpose
Bentonite Gel	Lightweight/Lost circulation prevention
Calcium Chloride	Accelerator
Cello-flake	Lost circulation prevention
Sodium Metasilicate	Accelerator
MagOx	Expansive agent
Pre-Mag-M	Expansive agent
Sodium Chloride	Accelerator
FL-62	Fluid loss control
Halad-344	Fluid loss control
Halad-9	Fluid loss control
HR-601	Retarder
Microbond	Expansive Agent

Cement integrity tests will be performed immediately following plug bump.

Note: Cement volumes based on bit size plus at least 25% excess in the open hole plus 10% excess in the cased-hole overlap section.

EOG requests variance from minimum standards to pump a two stage cement job on the production casing string with the first stage being pumped conventionally with the calculated top of cement at the top of the Brushy Canyon and the second stage performed as a 1000 sack bradenhead squeeze with planned cement from the Brushy Canyon to surface. If necessary, a top out consisting of 400 sacks of Class C cement + 3% Salt + 1% PreMag-M + 6% Bentonite Gel (1.32 yld, 14.8 ppg) will be executed as a contingency. Top will be verified by Echo-meter.

Bradenhead will be the primary option for production cementing. EOG also requests to have the conventional option in place to accommodate for logistical or wellbore conditions. The tie back requirements will be met if the cement is pumped conventionally, and cement volumes will be adjusted accordingly. TOC will be verified by CBL.



MUD PROGRAM:

During this procedure we plan to use a Closed-Loop System and haul contents to the required disposal. The applicable depths and properties of the drilling fluid systems are as follows:

Measured Depth	Type	Weight (ppg)	Viscosity	Water Loss
0 – 2,030'	Fresh - Gel	8.6-8.8	28-34	N/c
2,030' – 7,793'	Brine	9-10.5	28-34	N/c
5,450' – 28,578' Lateral	Oil Base	8.8-9.5	58-68	N/c - 6

An electronic pit volume totalizer (PVT) will be utilized on the circulating system, to monitor pit volume, flow rate, pump pressure and stroke rate.

Sufficient mud materials to maintain mud properties and meet minimum lost circulation and weight increase requirements will be kept at the wellsite at all times.



Appendix A - Spec Sheets

[New Search »](#)

[« Back to Previous List](#)

USC Metric

6/8/2015 10:04:37 AM

Mechanical Properties	Pipe	BTC	LTC	STC	
Minimum Yield Strength	55,000	--	--	--	psi
Maximum Yield Strength	80,000	--	--	--	psi
Minimum Tensile Strength	75,000	--	--	--	psi
Dimenstons	Pipe	BTC	LTC	STC	
Outside Diameter	13.375	14.375	--	14.375	in.
Wall Thickness	0.380	--	--	--	in.
Inside Diameter	12.615	12.615	--	12.615	in.
Standard Drift	12.459	12.459	--	12.459	in.
Alternate Drift	--	--	--	--	in.
Nominal Linear Weight, T&C	54.50	--	--	--	lbs/ft
Plain End Weight	52.79	--	--	--	lbs/ft
Performance	Pipe	BTC	LTC	STC	
Minimum Collapse Pressure	1,130	1,130	--	1,130	psi
Minimum Internal Yield Pressure	2,740	2,740	--	2,740	psi
Minimum Pipe Body Yield Strength	853.00	--	--	--	1000 lbs
Joint Strength	--	909	--	514	1000 lbs
Reference Length	--	11,125	--	6,290	ft
Make-Up Data	Pipe	BTC	LTC	STC	
Make-Up Loss	--	4.81	--	3.50	in.
Minimum Make-Up Torque	--	--	--	3,860	ft-lbs
Maximum Make-Up Torque	--	--	--	6,430	ft-lbs

9.625 40.00/0.395 J55

[New Search »](#)

[Back to Previous List](#)

USC Metric

6/8/2015 10:23:27 AM

Mechanical Properties	Pipe	BTC	LTC	STC	
Minimum Yield Strength	55,000	--	--	--	psi
Maximum Yield Strength	80,000	--	--	--	psi
Minimum Tensile Strength	75,000	--	--	--	psi
Dimenstons	Pipe	BTC	LTC	STC	
Outside Diameter	9.625	10.625	10.625	10.625	in.
Wall Thickness	0.395	--	--	--	in.
Inside Diameter	8.835	8.835	8.835	8.835	in.
Standard Drift	8.679	8.679	8.679	8.679	in.
Alternate Drift	8.750	8.750	8.750	8.750	in.
Nominal Linear Weight, T&C	40.00	--	--	--	lbs/ft
Plain End Weight	38.97	--	--	--	lbs/ft
Performance	Pipe	BTC	LTC	STC	
Minimum Collapse Pressure	2,570	2,570	2,570	2,570	psi
Minimum Internal Yield Pressure	3,950	3,950	3,950	3,950	psi
Minimum Pipe Body Yield Strength	630.00	--	--	--	1000 lbs
Joint Strength	--	714	520	452	1000 lbs
Reference Length	--	11,898	8,665	7,529	ft
Make-Up Data	Pipe	BTC	LTC	STC	
Make-Up Loss	--	4.81	4.75	3.38	in.
Minimum Make-Up Torque	--	--	3,900	3,390	ft-lbs
Maximum Make-Up Torque	--	--	6,500	5,650	ft-lbs



Connection Data Sheet

OD (in.)	WEIGHT (lbs./ft.)	WALL (in.)	GRADE	API DRIFT (in.)	RBW%	CONNECTION
5.500	Nominal: 20.00 Plain End: 19.83	0.361	VST P110EC	4.653	87.5	DWC/C-IS MS

PIPE PROPERTIES			CONNECTION PROPERTIES		
Outside Diameter	5.500	in.	Connection Type	Semi-Premium T&C	
Inside Diameter	4.778	in.	Connection O.D. (nom)	6.115	in.
Nominal Area	5.828	sq.in.	Connection I.D. (nom)	4.778	in.
Grade Type	API 5CT		Make-Up Loss	4.125	in.
Min. Yield Strength	125	ksi	Coupling Length	9.250	in.
Max. Yield Strength	140	ksi	Critical Cross Section	5.828	sq.in.
Min. Tensile Strength	135	ksi	Tension Efficiency	100.0%	of pipe
Yield Strength	729	klb	Compression Efficiency	100.0%	of pipe
Ultimate Strength	787	klb	Internal Pressure Efficiency	100.0%	of pipe
Min. Internal Yield	14,360	psi	External Pressure Efficiency	100.0%	of pipe
Collapse	12,090	psi			

CONNECTION PERFORMANCES			FIELD END TORQUE VALUES		
Yield Strength	729	klb	Min. Make-up torque	16,100	ft.lb
Parting Load	787	klb	Opti. Make-up torque	17,350	ft.lb
Compression Rating	729	klb	Max. Make-up torque	18,600	ft.lb
Min. Internal Yield	14,360	psi	Min. Shoulder Torque	1,610	ft.lb
External Pressure	12,090	psi	Max. Shoulder Torque	12,880	ft.lb
Maximum Uniaxial Bend Rating	104.2	°/100 ft	Min. Delta Turn	-	Turns
Reference String Length w 1.4 Design Factor	26,040	ft	Max. Delta Turn	0.200	Turns
			Maximum Operational Torque	21,100	ft.lb
			Maximum Torsional Value (MTV)	23,210	ft.lb

Need Help? Contact: tech.support@vam-usa.com
 Reference Drawing: 8136PP Rev.01 & 8136BP Rev.01
 Date: 12/03/2019
 Time: 06:19:27 PM

For detailed information on performance properties, refer to DWC Connection Data Notes on following page(s).

Connection specifications within the control of VAM USA were correct as of the date printed. Specifications are subject to change without notice. Certain connection specifications are dependent on the mechanical properties of the pipe. Mechanical properties of mill proprietary pipe grades were obtained from mill publications and are subject to change. Properties of mill proprietary grades should be confirmed with the mill. Users are advised to obtain current connection specifications and verify pipe mechanical properties for each application.

All information is provided by VAM USA or its affiliates at user's sole risk, without liability for loss, damage or injury resulting from the use thereof; and on an "AS IS" basis without warranty or representation of any kind, whether express or implied, including without limitation any warranty of merchantability, fitness for purpose or completeness. This document and its contents are subject to change without notice. In no event shall VAM USA or its affiliates be responsible for any indirect, special, incidental, punitive, exemplary or consequential loss or damage (including without limitation, loss of use, loss of bargain, loss of revenue, profit or anticipated profit) however caused or arising, and whether such losses or damages were foreseeable or VAM USA or its affiliates was advised of the possibility of such damages.



VAM USA
2107 CityWest Boulevard Suite 1300
Houston, TX 77042
Phone: 713-479-3200
Fax: 713-479-3234
VAM® USA Sales E-mail: VAMUSAsales@vam-usa.com
Tech Support Email: tech.support@vam-usa.com

DWC Connection Data Sheet Notes:

1. DWC connections are available with a seal ring (SR) option.
2. All standard DWC/C connections are interchangeable for a given pipe OD. DWC connections are interchangeable with DWC/C-SR connections of the same OD and wall.
3. Connection performance properties are based on nominal pipe body and connection dimensions.
4. DWC connection internal and external pressure resistance is calculated using the API rating for buttress connections. API Internal pressure resistance is calculated from formulas 31, 32, and 35 in the API Bulletin 5C3.
5. DWC joint strength is the minimum pipe body yield strength multiplied by the connection critical area.
6. API joint strength is for reference only. It is calculated from formulas 42 and 43 in the API Bulletin 5C3.
7. Bending efficiency is equal to the compression efficiency.
8. The torque values listed are recommended. The actual torque required may be affected by field conditions such as temperature, thread compound, speed of make-up, weather conditions, etc.
9. Connection yield torque is not to be exceeded.
10. Reference string length is calculated by dividing the joint strength by both the nominal weight in air and a design factor (DF) of 1.4. These values are offered for reference only and do not include load factors such as bending, buoyancy, temperature, load dynamics, etc.
11. DWC connections will accommodate API standard drift diameters.
12. DWC/C family of connections are compatible with API Buttress BTC connections. Please contact tech.support@vam-usa.com for details on connection ratings and make-up.



Connection specifications within the control of VAM USA were correct as of the date printed. Specifications are subject to change without notice. Certain connection specifications are dependent on the mechanical properties of the pipe. Mechanical properties of mill proprietary pipe grades were obtained from mill publications and are subject to change. Properties of mill proprietary grades should be confirmed with the mill. Users are advised to obtain current connection specifications and verify pipe mechanical properties for each application.

All information is provided by VAM USA or its affiliates at user's sole risk, without liability for loss, damage or injury resulting from the use thereof; and on an "AS IS" basis without warranty or representation of any kind, whether express or implied, including without limitation any warranty of merchantability, fitness for purpose or completeness. This document and its contents are subject to change without notice. In no event shall VAM USA or its affiliates be responsible for any indirect, special, incidental, punitive, exemplary or consequential loss or damage (including without limitation, loss of use, loss of bargain, loss of revenue, profit or anticipated profit) however caused or arising, and whether such losses or damages were foreseeable or VAM USA or its affiliates was advised of the possibility of such damages.

10.750 40.50/0.350 J55

PDF

[New Search »](#)

[« Back to Previous List](#)

USC Metric

6/8/2015 10:14:05 AM

Mechanical Properties	Pipe	BTC	LTC	STC	
Minimum Yield Strength	55,000	--	--	--	psi
Maximum Yield Strength	80,000	--	--	--	psi
Minimum Tensile Strength	75,000	--	--	--	psi
Dimenstons	Pipe	BTC	LTC	STC	
Outside Diameter	10.750	11.750	--	11.750	in.
Wall Thickness	0.350	--	--	--	in.
Inside Diameter	10.050	10.050	--	10.050	in.
Standard Drift	9.894	9.894	--	9.894	in.
Alternate Drift	--	--	--	--	in.
Nominal Linear Weight, T&C	40.50	--	--	--	lbs/ft
Plain End Weight	38.91	--	--	--	lbs/ft
Performance	Pipe	BTC	LTC	STC	
Minimum Collapse Pressure	1,580	1,580	--	1,580	psi
Minimum Internal Yield Pressure	3,130	3,130	--	3,130	psi
Minimum Pipe Body Yield Strength	629.00	--	--	--	1000 lbs
Joint Strength	--	700	--	420	1000 lbs
Reference Length	--	11,522	--	6,915	ft
Make-Up Data	Pipe	BTC	LTC	STC	
Make-Up Loss	--	4.81	--	3.50	in.
Minimum Make-Up Torque	--	--	--	3,150	ft-lbs
Maximum Make-Up Torque	--	--	--	5,250	ft-lbs

Released to Imaging: 3/9/2026 1:23:32 PM



API 5CT, 10th Ed. Connection Data Sheet

O.D. (in)	WEIGHT (lb/ft)	WALL (in)	GRADE	*API DRIFT (in)	RBW %
8.625	Nominal: 32.00 Plain End: 31.13	0.352	J55	7.796	87.5

Material Properties (PE)

Pipe	
Minimum Yield Strength:	55 ksi
Maximum Yield Strength:	80 ksi
Minimum Tensile Strength:	75 ksi
Coupling	
Minimum Yield Strength:	55 ksi
Maximum Yield Strength:	80 ksi
Minimum Tensile Strength:	75 ksi

Pipe Body Data (PE)

Geometry	
Nominal ID:	7.92 inch
Nominal Area:	9.149 in ²
*Special/Alt. Drift:	7.875 inch
Performance	
Pipe Body Yield Strength:	503 kips
Collapse Resistance:	2,530 psi
Internal Yield Pressure: (API Historical)	3,930 psi

API Connection Data

Coupling OD: 9.625"

STC Performance	
STC Internal Pressure:	3,930 psi
STC Joint Strength:	372 kips
LTC Performance	
LTC Internal Pressure:	3,930 psi
LTC Joint Strength:	417 kips
SC-BTC Performance - Cplg OD = 9.125"	
BTC Internal Pressure:	3,930 psi
BTC Joint Strength:	503 kips

API Connection Torque

STC Torque (ft-lbs)					
Min:	2,793	Opti:	3,724	Max:	4,655
LTC Torque (ft-lbs)					
Min:	3,130	Opti:	4,174	Max:	5,217
BTC Torque (ft-lbs)					
<i>follow API guidelines regarding positional make up</i>					

*Alt. Drift will be used unless API Drift is specified on order.

**If above API connections do not suit your needs, VAM® premium connections are available up to 100% of pipe body ratings.

ALL INFORMATION IS PROVIDED BY VALLOUREC OR ITS AFFILIATES AT USER'S SOLE RISK, WITHOUT LIABILITY FOR LOSS, DAMAGE OR INJURY RESULTING FROM THE USE THEREOF; AND ON AN "AS IS" BASIS WITHOUT WARRANTY OR REPRESENTATION OF ANY KIND, WHETHER EXPRESS OR IMPLIED, INCLUDING WITHOUT LIMITATION ANY WARRANTY OF MERCHANTABILITY, FITNESS FOR PURPOSE, ACCURACY OR COMPLETENESS. THE INFORMATION CONTAINED IN THIS DOCUMENT IS PROVIDED FOR INFORMATIONAL PURPOSES ONLY AND IS BASED ON ESTIMATES THAT HAVE NOT BEEN VERIFIED OR TESTED. IN NO EVENT SHALL VALLOUREC OR ITS AFFILIATES BE RESPONSIBLE FOR ANY INDIRECT, SPECIAL, INCIDENTAL, PUNITIVE, EXEMPLARY OR CONSEQUENTIAL LOSS OR DAMAGE (INCLUDING WITHOUT LIMITATION, LOSS OF USE, LOSS OF BARGAIN, LOSS OF REVENUE, PROFIT OR ANTICIPATED PROFIT) HOWEVER CAUSED OR ARISING, AND WHETHER SUCH LOSSES OR DAMAGES WERE FORESEEABLE OR VALLOUREC OR ITS AFFILIATES WERE ADVISED OF THE POSSIBILITY OF SUCH DAMAGES.

VALLOUREC STAR 8.625 32# J55 S S2L2 DA 7.875 W/O# SLN# PO# MADE IN USA FT LB

Issued on: 10 Feb. 2021 by Wesley Ott



Connection Data Sheet

OD 6 in.	Weight (lb/ft) Nominal: 24.50 Plain End: 23.95	Wall Th. 0.400 in.	Grade P110EC	API Drift: 5.075 in.	Connection VAM® SPRINT-SF
-------------	--	-----------------------	-----------------	-------------------------	-------------------------------------

PIPE PROPERTIES	
Nominal OD	6.000 in.
Nominal ID	5.200 in.
Nominal Cross Section Area	7.037 sqin.
Grade Type	High Yield
Min. Yield Strength	125 ksi
Max. Yield Strength	140 ksi
Min. Ultimate Tensile Strength	135 ksi

CONNECTION PROPERTIES	
Connection Type	Integral Semi-Flush
Connection OD (nom):	6.277 in.
Connection ID (nom):	5.146 in.
Make-Up Loss	5.386 in.
Critical Cross Section	6.417 sqin.
Tension Efficiency	91.0 % of pipe
Compression Efficiency	91.0 % of pipe
Internal Pressure Efficiency	100 % of pipe
External Pressure Efficiency	100 % of pipe

CONNECTION PERFORMANCES	
Tensile Yield Strength	801 klb
Compression Resistance	801 klb
Internal Yield Pressure	14,580 psi
Collapse Resistance	12,500 psi
Max. Structural Bending	83 °/100ft
Max. Bending with ISO/API Sealability	30 °/100ft

TORQUE VALUES	
Min. Make-up torque	21,750 ft.lb
Opt. Make-up torque	24,250 ft.lb
Max. Make-up torque	26,750 ft.lb
Max. Torque with Sealability (MTS)	53,000 ft.lb

* 87.5% RBW

VAM® SPRINT-SF is a semi-flush connection innovatively designed for extreme shale applications. Its high tension rating and ultra high torque capacity make it ideal to run a fill string length as production casing in shale wells with extended horizontal sections and tight clearance requirements.

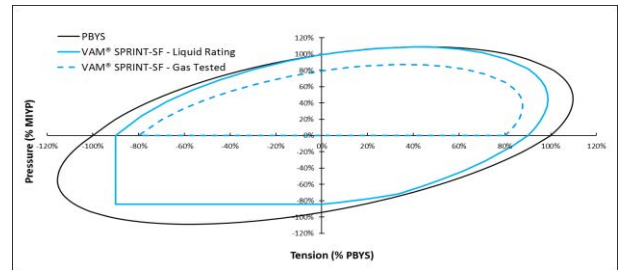

Do you need help on this product? - Remember no one knows VAM® like VAM®

<p>canada@vamfieldservice.com usa@vamfieldservice.com mexico@vamfieldservice.com brazil@vamfieldservice.com</p>	<p>uk@vamfieldservice.com dubai@vamfieldservice.com nigeria@vamfieldservice.com angola@vamfieldservice.com</p>	<p>china@vamfieldservice.com baku@vamfieldservice.com singapore@vamfieldservice.com australia@vamfieldservice.com</p>
---	--	---

Over 140 VAM® Specialists available worldwide 24/7 for Rig Site Assistance





Connection Data Sheet

OD (in.) 6.000	WEIGHT (lbs./ft.) Nominal: 22.30 Plain End: 21.70	WALL (in.) 0.360	GRADE VST P110EC	API DRIFT (in.) 5.155	RBW% 92.5	CONNECTION DWC/C-IS
-------------------	---	---------------------	---------------------	--------------------------	--------------	------------------------

PIPE PROPERTIES		
Nominal OD	6.000	in.
Nominal ID	5.280	in.
Nominal Area	6.379	sq.in.
Grade Type	API 5CT	
Min. Yield Strength	125	ksi
Max. Yield Strength	140	ksi
Min. Tensile Strength	135	ksi
Yield Strength	797	klb
Ultimate Strength	861	klb
Min. Internal Yield Pressure	13,880	psi
Collapse Pressure	9,800	psi

CONNECTION PROPERTIES		
Connection Type	Semi-Premium T&C	
Connection OD (nom)	6.650	in.
Connection ID (nom)	5.280	in.
Make-Up Loss	4.313	in.
Coupling Length	9.625	in.
Critical Cross Section	6.379	sq.in.
Tension Efficiency	100.0%	of pipe
Compression Efficiency	100.0%	of pipe
Internal Pressure Efficiency	100.0%	of pipe
External Pressure Efficiency	100.0%	of pipe

CONNECTION PERFORMANCES		
Yield Strength	797	klb
Parting Load	861	klb
Compression Rating	797	klb
Min. Internal Yield	13,880	psi
External Pressure	9,800	psi
Maximum Uniaxial Bend Rating	47.7	^o /100 ft
Reference String Length w 1.4 Design Factor	25,530	ft.

FIELD END TORQUE VALUES		
Min. Make-up torque	17,000	ft.lb
Opti. Make-up torque	18,250	ft.lb
Max. Make-up torque	19,500	ft.lb
Min. Shoulder Torque	1,700	ft.lb
Max. Shoulder Torque	13,600	ft.lb
Min. Delta Turn	-	Turns
Max. Delta Turn	0.200	Turns
Maximum Operational Torque	24,200	ft.lb
Maximum Torsional Value (MTV)	26,620	ft.lb

Need Help? Contact: tech.support@vam-usa.com
 Reference Drawing: 8135PP Rev.02 & 8135BP Rev.02
 Date: 07/30/2020
 Time: 07:50:47 PM

For detailed information on performance properties, refer to DWC Connection Data Notes on following page(s).

Connection specifications within the control of VAM USA were correct as of the date printed. Specifications are subject to change without notice. Certain connection specifications are dependent on the mechanical properties of the pipe. Mechanical properties of mill proprietary pipe grades were obtained from mill publications and are subject to change. Properties of mill proprietary grades should be confirmed with the mill. Users are advised to obtain current connection specifications and verify pipe mechanical properties for each application.

All information is provided by VAM USA or its affiliates at user's sole risk, without liability for loss, damage or injury resulting from the use thereof; and on an "AS IS" basis without warranty or representation of any kind, whether express or implied, including without limitation any warranty of merchantability, fitness for purpose or completeness. This document and its contents are subject to change without notice. In no event shall VAM USA or its affiliates be responsible for any indirect, special, incidental, punitive, exemplary or consequential loss or damage (including without limitation, loss of use, loss of bargain, loss of revenue, profit or anticipated profit) however caused or arising, and whether such losses or damages were foreseeable or VAM USA or its affiliates was advised of the possibility of such damages.





VAM USA
2107 CityWest Boulevard Suite 1300
Houston, TX 77042
Phone: 713-479-3200
Fax: 713-479-3234

VAM® USA Sales E-mail: VAMUSAsales@vam-usa.com
Tech Support Email: tech.support@vam-usa.com

DWC Connection Data Sheet Notes:

1. DWC connections are available with a seal ring (SR) option.
2. All standard DWC/C connections are interchangeable for a given pipe OD. DWC connections are interchangeable with DWC/C-SR connections of the same OD and wall.
3. Connection performance properties are based on nominal pipe body and connection dimensions.
4. DWC connection internal and external pressure resistance is calculated using the API rating for buttress connections. API Internal pressure resistance is calculated from formulas 31, 32, and 35 in the API Bulletin 5C3.
5. DWC joint strength is the minimum pipe body yield strength multiplied by the connection critical area.
6. API joint strength is for reference only. It is calculated from formulas 42 and 43 in the API Bulletin 5C3.
7. Bending efficiency is equal to the compression efficiency.
8. The torque values listed are recommended. The actual torque required may be affected by field conditions such as temperature, thread compound, speed of make-up, weather conditions, etc.
9. Connection yield torque is not to be exceeded.
10. Reference string length is calculated by dividing the joint strength by both the nominal weight in air and a design factor (DF) of 1.4. These values are offered for reference only and do not include load factors such as bending, buoyancy, temperature, load dynamics, etc.
11. DWC connections will accommodate API standard drift diameters.
12. DWC/C family of connections are compatible with API Buttress BTC connections. Please contact tech.support@vam-usa.com for details on connection ratings and make-up.

Connection specifications within the control of VAM USA were correct as of the date printed. Specifications are subject to change without notice. Certain connection specifications are dependent on the mechanical properties of the pipe. Mechanical properties of mill proprietary pipe grades were obtained from mill publications and are subject to change. Properties of mill proprietary grades should be confirmed with the mill. Users are advised to obtain current connection specifications and verify pipe mechanical properties for each application.

All information is provided by VAM USA or its affiliates at user's sole risk, without liability for loss, damage or injury resulting from the use thereof; and on an "AS IS" basis without warranty or representation of any kind, whether express or implied, including without limitation any warranty of merchantability, fitness for purpose or completeness. This document and its contents are subject to change without notice. In no event shall VAM USA or its affiliates be responsible for any indirect, special, incidental, punitive, exemplary or consequential loss or damage (including without limitation, loss of use, loss of bargain, loss of revenue, profit or anticipated profit) however caused or arising, and whether such losses or damages were foreseeable or VAM USA or its affiliates was advised of the possibility of such damages.





EOG Batch Casing

Pad Name: Pegasus 3 Fed Com P&A Sundry

SHL: Section 3, Township 24-S, Range 32-E, LEA County, NM

EOG requests for the below wells to be approved for all designs listed in the Blanket Casing Design ('EOG BLM Variance 5a - Alternate Shallow Casing Designs.pdf' OR 'EOG BLM Variance 5b - Alternate Deep Casing Designs.pdf') document. The MDs and TVDs for all intervals are within the boundary conditions. The max inclination and DLS are also within the boundary conditions. The directional plans for the wells are attached separately.

Well Name	API #	Surface		Intermediate		Production	
		MD	TVD	MD	TVD	MD	TVD
Pegasus 3 Fed Com #324H	30-025-*****	1,272	1,272	5,109	4,960	20,258	9,919
Pegasus 3 Fed Com #325H	30-025-*****	1,272	1,272	5,058	4,960	20,184	9,889



EOG Batch Casing

GEOLOGIC NAME OF SURFACE FORMATION:

Permian

ESTIMATED TOPS OF IMPORTANT GEOLOGICAL MARKERS:

Rustler	1,178'
Tamarisk Anhydrite	1,247'
Top of Salt	1,479'
Base of Salt	4,682'
Lamar	4,910'
Bell Canyon	4,935'
Cherry Canyon	5,774'
Brushy Canyon	7,128'
Bone Spring Lime	8,755'
Leonard (Avalon) Shale	8,898'
1st Bone Spring Sand	9,920'

3. ESTIMATED DEPTHS OF ANTICIPATED FRESH WATER, OIL OR GAS:

Upper Permian Sands	0- 400' Fresh Water
Lamar	4,910' Oil
Cherry Canyon	5,774' Oil
Brushy Canyon	7,128' Oil
Bone Spring Lime	8,755' Oil
Leonard (Avalon) Shale	8,898' Oil
1st Bone Spring Sand	9,920' Oil



EOG Batch Casing

Variations

EOG requests the additional variance(s) in the attached document(s):

- EOG BLM Variance 2a - Intermediate Bradenhead Cement
- EOG BLM Variance 3d - Production Offline Cement
- EOG BLM Variance 3e - BOP Break-test and Offline Surface and Intermediate Cement
- EOG BLM Variance 4a - Salt Section Annular Clearance
- EOG BLM Variance 5a - Alternate Shallow Casing Designs



Master Variance Document

—

Table of Contents

- [BOPE Break Test \(3/25/2025\)](#)
- [Offline Surface/Intermediate Cement \(8/15/2023\)](#)
- [Intermediate Bradenhead Cement \(Deep Targets\) \(8/15/2023\)](#)
- [Wolfcamp Intermediate Casing Setpoint \(6/26/2024\)](#)
- [Offline Production Cement \(11/12/2024\)](#)
- [Production Bradenhead Cement \(8/9/2024\)](#)
- [Salt Section Annular Clearance \(11/8/2022\)](#)



BOPE Break Test Variance

—

EOG BOPE Break Test Variance (Intervals 5M MASP or less)

EOG Resources Inc. (EOG) respectfully requests a variance from the minimum standards for well control equipment testing of ECFR Title 43 Part 3172.6(b)(9)(iv) to allow a testing schedule of the blow out preventer (BOP) and blow out prevention equipment (BOPE) along with Batch Drilling & Offline cement operations to include the following:

- **Full BOPE test at first installation on the pad.**
- **Full BOPE test every 21 days.**
- **Break-test only available for the Base of the Wolfcamp or shallower**
 - If anything out of the ordinary is observed during drilling, tripping or casing running operations in the production hole section, break testing will not be performed in the subsequent well's production hole section.
 - Furthermore, break testing in the production hole section will not be performed if offset frac operations are observed within 1 mile and within the same producing horizon.
- **Each rig requesting the break-test variance is capable of picking up the BOP without damaging components using winches, following API Standard 53, Well Control Equipment Systems for Drilling Wells (Fifth edition, December 2018, Annex C. Table C.4) which recognizes break testing as an acceptable practice.**
- **Function tests will be performed on the following BOP elements:**
 - Annular → during each full BOPE test and at least weekly
 - Pipe Rams → Every trip and on trip ins where FIT required
 - Blind Rams → Every trip
- **Break testing BOP and BOPE coupled with batch drilling operations and option to offline cement and/or remediate (if needed) any surface, intermediate or production sections, according to attached offline cementing support documentation.**
- **After the well section is secured, the BOP will be disconnected from the wellhead and walked with the rig to another well on the pad.**
- **TA cap will also be installed per Wellhead vendor procedure and pressure inside the casing will be monitored via the valve on the TA cap as per standard batch drilling ops.**

Break Test Diagram (Test Joint)

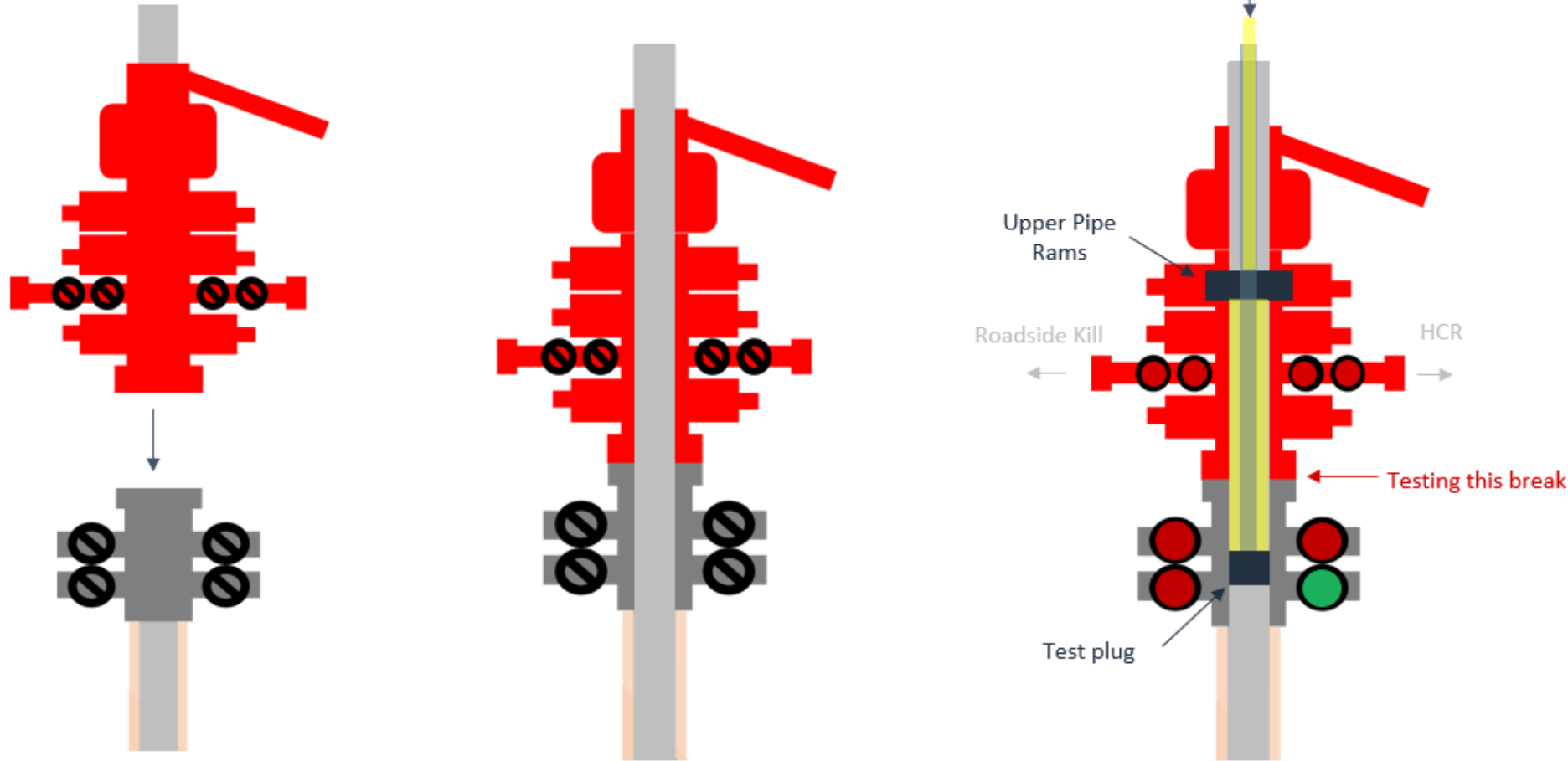

Steps

1. Set plug in with test joint wellhead (lower barrier)
2. Close Upper Pipe Rams (upper barrier)
3. Close roadside kill
4. Close HCR
5. Open wellhead valves below test plug to ensure if leak past test plug, pressure won't be applied to wellbore
6. Tie BOP testers high pressure line to top of test joint
7. Pressure up to test break
8. Bleed test pressure from BOP testing unit



Offline Surface + Intermediate Variance

—

Offline Surface + Intermediate Cement

Cement Program

1. No changes to the cement program will take place for offline cementing.

Summarized Operational Procedure for Intermediate Casing

1. Run casing as per normal operations. While running casing, conduct negative pressure test and confirm integrity of the float equipment back pressure valves.
 - a. Float equipment is equipped with two back pressure valves rated to a minimum of 5,000 psi.
2. Land production casing on mandrel hanger through BOP.
 - a. If casing is unable to be landed with a mandrel hanger, then the **casing will be cemented online.**
3. Break circulation and confirm no restrictions.
 - a. Ensure no blockage of float equipment and appropriate annular returns.
 - b. Perform flow check to confirm well is static.
4. Set pack-off
 - a. If utilizing a fluted/ported mandrel hanger, ensure well is static on the annulus and inside the casing by filling the pipe with kill weight fluid, remove landing joint, and set annular packoff through BOP. Pressure test to 5,000 psi for 10 min.
 - b. If utilizing a solid mandrel hanger, ensure well is static on the annulus and inside the casing by filling the pipe with kill weight fluid. Pressure test seals to 5,000 psi for 10 min. Remove landing joint through BOP.
5. After confirmation of both annular barriers and the two casing barriers, install TA plug and pressure test to 5,000 psi for 10 min. Notify the BLM with intent to proceed with nipple down and offline cementing.
 - a. Minimum 4 hrs notice.
6. With the well secured and BLM notified, nipple down BOP and secure on hydraulic carrier or cradle.
 - a. **Note, if any of the barriers fail to test, the BOP stack will not be nipped down until after the cement job has concluded and both lead and tail slurry have reached 500 psi.**
7. Skid/Walk rig off current well.
8. Confirm well is static before removing TA Plug.
 - a. Cementing operations will not proceed until well is under control. (If well is not static, notify BLM and proceed to kill)
 - b. Casing outlet valves will provide access to both the casing ID and annulus. Rig or third party pump truck will kill well prior to cementing.
 - c. Well control plan can be seen in Section B, Well Control Procedures.
 - d. If need be, rig can be moved back over well and BOP nipped back up for any further remediation.

Offline Surface + Intermediate Cement

- e. Diagram for rig positioning relative to offline cementing can be seen in Figure 4.
9. Rig up return lines to take returns from wellhead to pits and rig choke.
 - a. Test all connections and lines from wellhead to choke manifold to 5,000 psi high for 10 min.
 - b. If either test fails, perform corrections and retest before proceeding.
 - c. Return line schematics can be seen in Figure 3.
10. Remove TA Plug from the casing.
11. Install offline cement tool.
 - a. Current offline cement tool schematics can be seen in Figure 1 (Cameron) and Figure 2 (Cactus).
12. Rig up cement head and cementing lines.
 - a. Pressure test cement lines against cement head to 80% of casing burst for 10 min.
13. Break circulation on well to confirm no restrictions.
 - a. If gas is present on circulation, well will be shut in and returns rerouted through gas buster.
 - b. Max anticipated time before circulating with cement truck is 6 hrs.
14. Pump cement job as per plan.
 - a. At plug bump, test casing to 0.22 psi/ft or 1500 psi, whichever is greater.
 - b. If plug does not bump on calculated, shut down and wait 8 hrs or 500 psi compressive strength, whichever is greater before testing casing.
15. Confirm well is static and floats are holding after cement job.
 - a. With floats holding and backside static:
 - i. Remove cement head.
 - b. If floats are leaking:
 - i. Shut-in well and WOC (Wait on Cement) until tail slurry reaches 500 psi compressive strength and the casing is static prior to removing cement head.
 - c. If there is flow on the backside:
 - i. Shut in well and WOC until tail slurry reaches 500 psi compressive strength. Ensure that the casing is static prior to removing cement head.
16. Remove offline cement tool.
17. Install night cap with pressure gauge for monitoring.
18. Test night cap to 5,000 psi for 10 min.

Offline Surface + Intermediate Cement

Example Well Control Plan Content

A. Well Control Component Table

The table below, which covers the cementing of the **5M MASP (Maximum Allowable Surface Pressure) portion of the well**, outlines the well control component rating in use. This table, combined with the mud program, documents that two barriers to flow can be maintained at all times, independent of the BOP nipped up to the wellhead.

Intermediate hole section, 5M requirement

Component	RWP
Pack-off	10M
Casing Wellhead Valves	10M
Annular Wellhead Valves	5M
TA Plug	10M
Float Valves	5M
2" 1502 Lo-Torque Valves	15M

B. Well Control Procedures

Well control procedures are specific to the rig equipment and the operation at the time the kick occurs. Below are the minimal high-level tasks prescribed to assure a proper shut-in while circulating and cementing through the Offline Cement Adapter.

General Procedure While Circulating

1. Sound alarm (alert crew).
2. Shut down pumps.
3. Shut-in Well (close valves to rig pits and open valve to rig choke line. Rig choke will already be in the closed position).
4. Confirm shut-in.
5. Notify tool pusher/company representative.

Offline Surface + Intermediate Cement

Example Well Control Plan Content

A. Well Control Component Table

The table below, which covers the cementing of the **5M MASP (Maximum Allowable Surface Pressure) portion of the well**, outlines the well control component rating in use. This table, combined with the mud program, documents that two barriers to flow can be maintained at all times, independent of the BOP nipped up to the wellhead.

Intermediate hole section, 5M requirement

Component	RWP
Pack-off	10M
Casing Wellhead Valves	10M
Annular Wellhead Valves	5M
TA Plug	10M
Float Valves	5M
2" 1502 Lo-Torque Valves	15M

B. Well Control Procedures

Well control procedures are specific to the rig equipment and the operation at the time the kick occurs. Below are the minimal high-level tasks prescribed to assure a proper shut-in while circulating and cementing through the Offline Cement Adapter.

General Procedure While Circulating

1. Sound alarm (alert crew).
2. Shut down pumps.
3. Shut-in Well (close valves to rig pits and open valve to rig choke line. Rig choke will already be in the closed position).
4. Confirm shut-in.
5. Notify tool pusher/company representative.

Offline Surface + Intermediate Cement

6. Read and record the following:
 - a. SICP (Shut in Casing Pressure) and AP (Annular Pressure)
 - b. Pit gain
 - c. Time
 - d. Regroup and identify forward plan to continue circulating out kick via rig choke and mud/gas separator. Circulate and adjust mud density as needed to control well.

General Procedure While Cementing

1. Sound alarm (alert crew).
2. Shut down pumps.
3. Shut-in Well (close valves to rig pits and open valve to rig choke line. Rig choke will already be in the closed position).
4. Confirm shut-in.
5. Notify tool pusher/company representative.
6. Open rig choke and begin pumping again taking returns through choke manifold and mud/gas separator.
7. Continue to place cement until plug bumps.
8. At plug bump close rig choke and cement head.
9. Read and record the following
 - a. SICP and AP
 - b. Pit gain
 - c. Time
 - d. Shut-in annulus valves on wellhead

General Procedure After Cementing

1. Sound alarm (alert crew).
2. Shut-in Well (close valves to rig pits and open valve to rig choke line. Rig choke will already be in the closed position).
3. Confirm shut-in.
4. Notify tool pusher/company representative.
5. Read and record the following:
 - a. SICP and AP
 - b. Pit gain
 - d. Shut-in annulus valves on wellhead

Offline Surface + Intermediate Cement

Figure 1: Cameron TA Plug and Offline Adapter Schematic

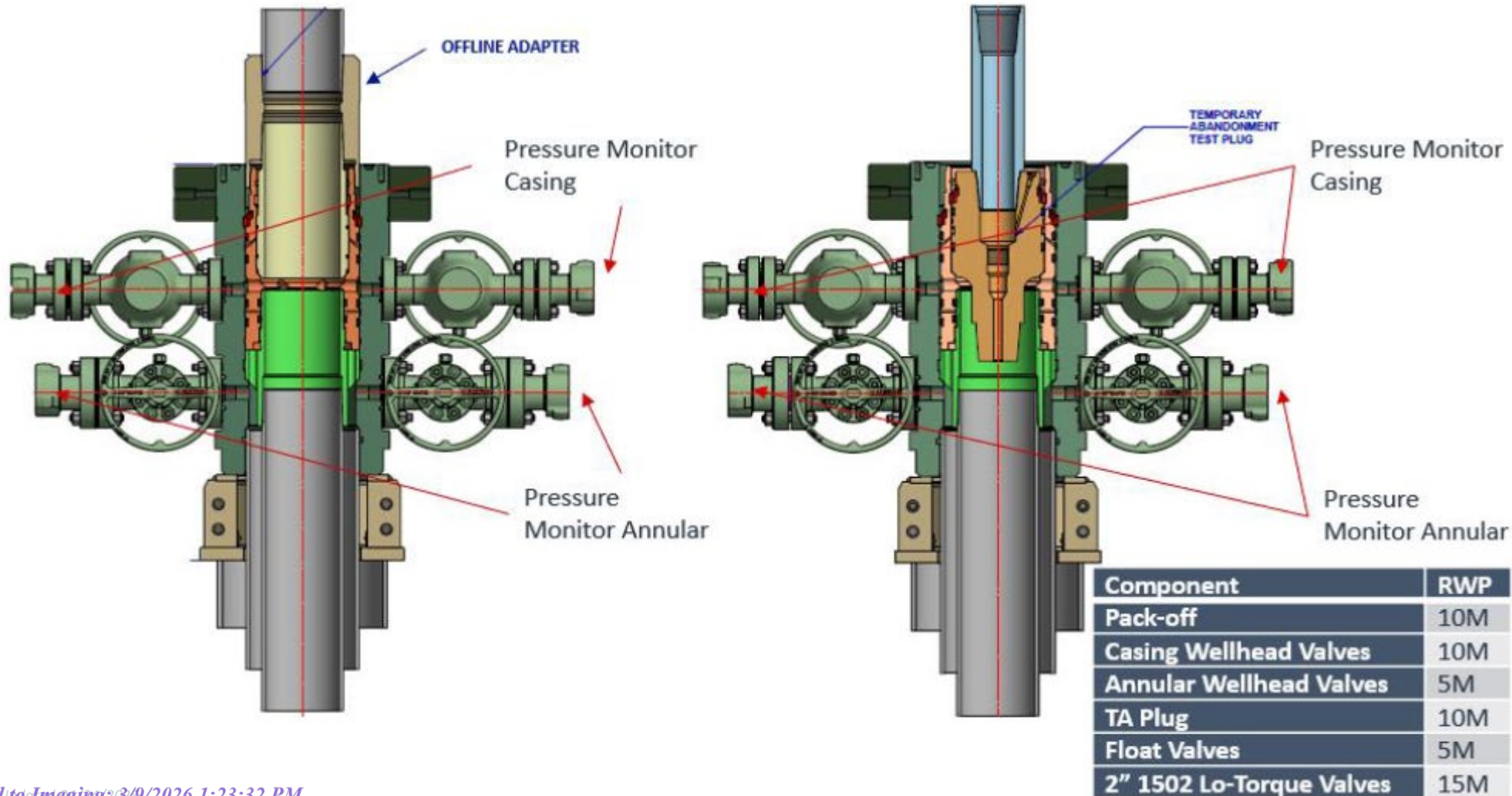

Offline Surface + Intermediate Cement

Figure 2: Cactus TA Plug and Offline Adapter Schematic

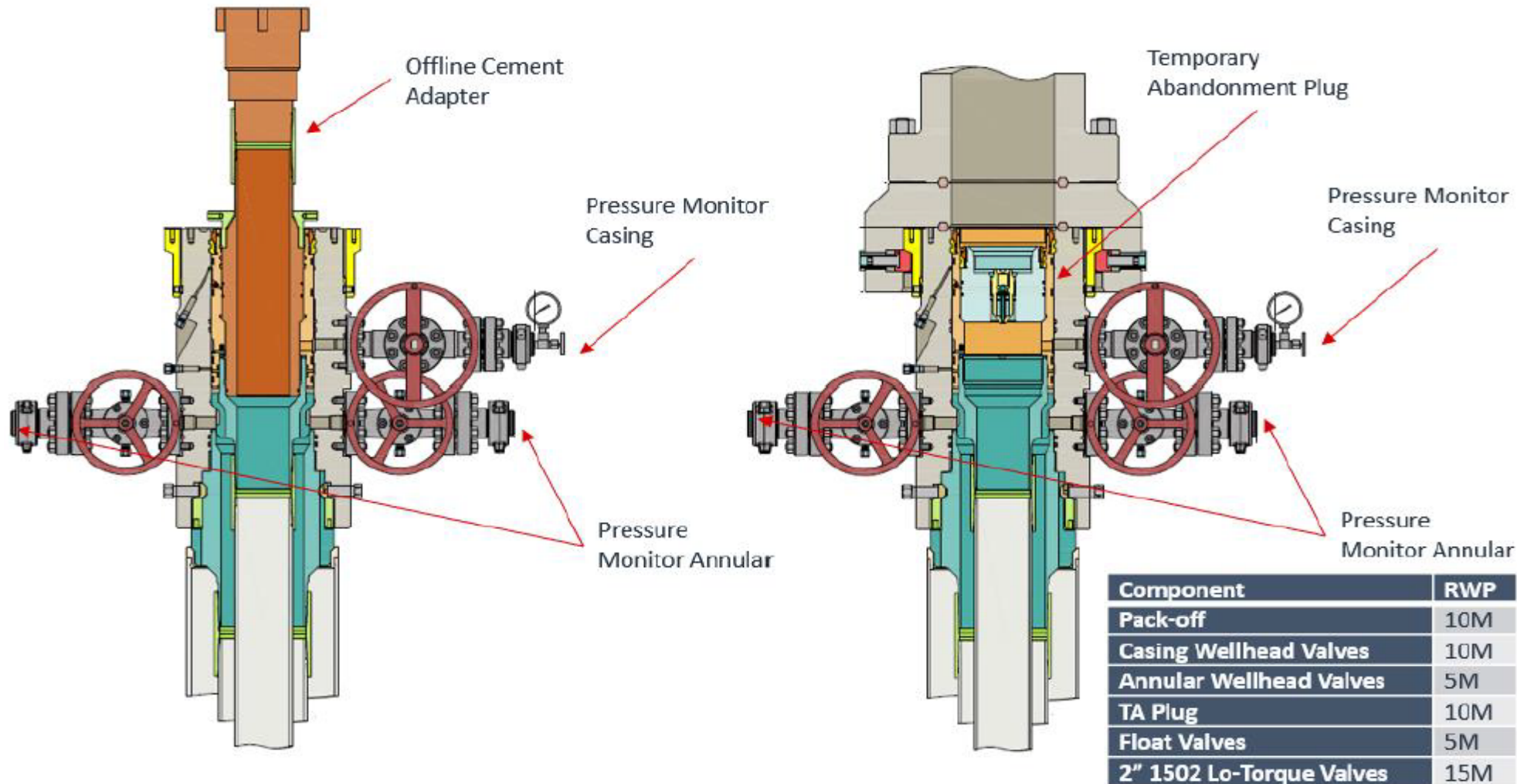

Offline Surface + Intermediate Cement

Figure 3: Back Yard Rig Up

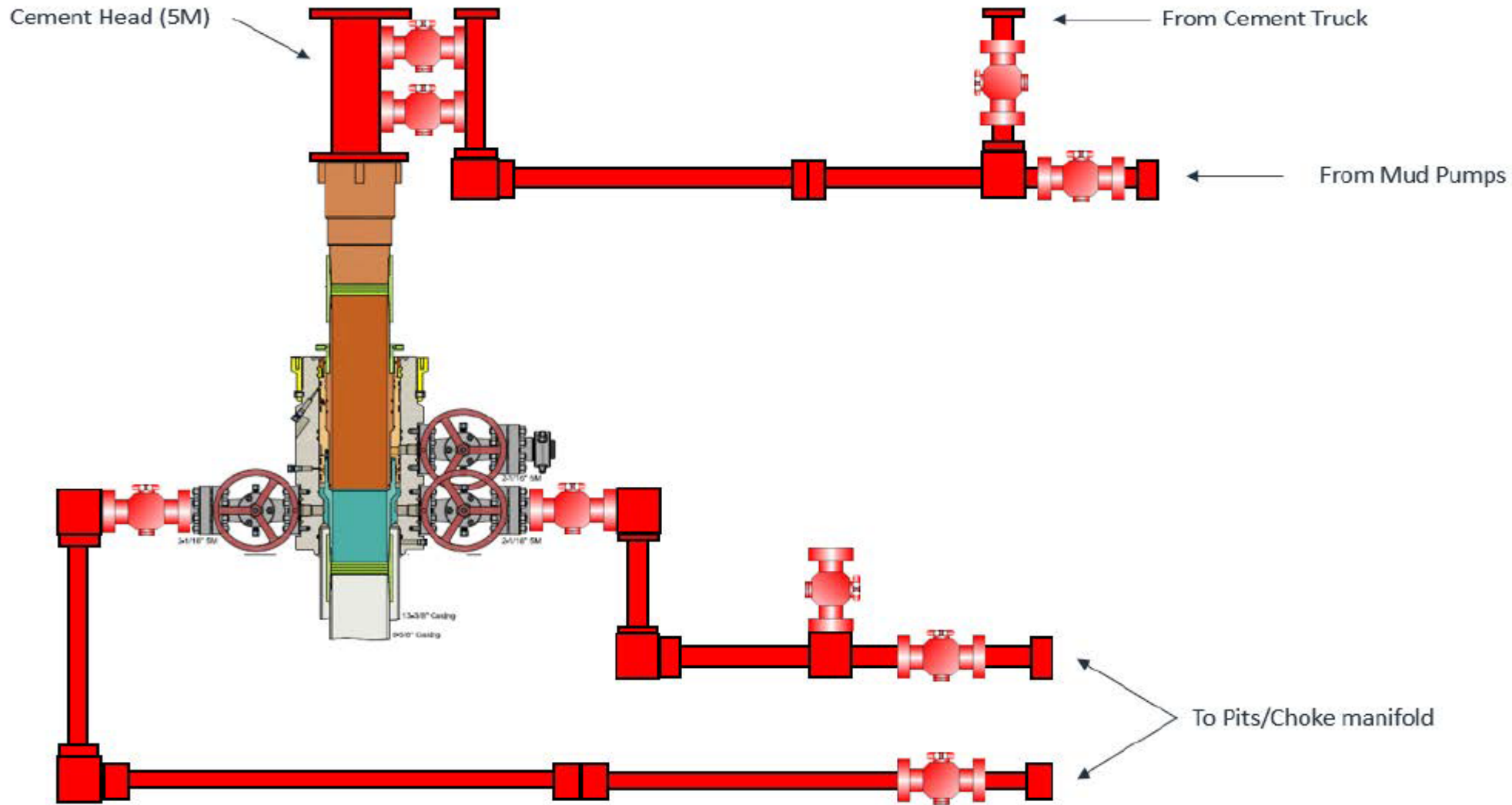

Offline Surface + Intermediate Cement

Figure 4: Rig Placement Diagram

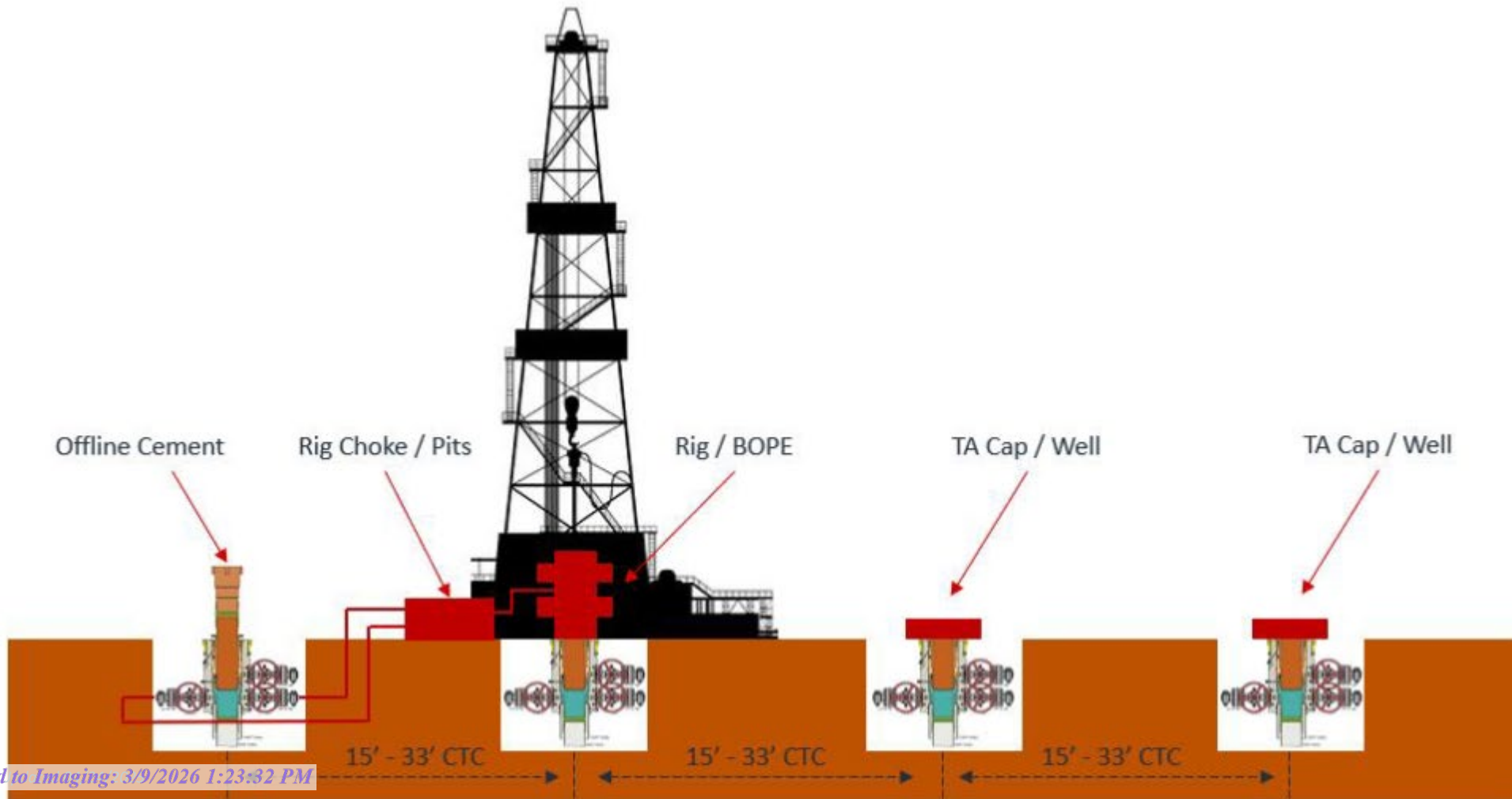



Intermediate Bradenhead Cement Variance

Intermediate Bradenhead Cement

Deep Target Intermediate Bradenhead:

EOG requests variance from minimum standards to pump a two stage cement job on the intermediate casing string **when set below the Delaware Mountain Group** with the first stage being pumped conventionally with the calculated top of cement at the Brushy Canyon and the second stage bradenhead squeezed to be performed at a minimum of **50% of OH excess (typically increased to ~1,000 sacks)** with planned cement from the Brushy Canyon to surface. If necessary, a top out consisting of Class C/H cement + additives (2.30 yld, 12.91 ppg) will be executed as a contingency. Top of cement will be verified by Echo-meter.

EOG will include the Echo-meter verified fluid top and the volume of displacement fluid above the cement slurry in the annulus in all post-drill sundries on wells utilizing this cement program.

EOG will report to the BLM the volume of fluid (limited to 5 bbls) used to flush intermediate casing valves following backside cementing procedures.



Wolfcamp Intermediate Casing Setpoint

Intermediate Bradenhead Cement

EOG Resources Inc. (EOG) requests a variance to set the intermediate casing shoe in the Bone Spring formation OR the Wolfcamp formation, depending on depletion in the area and well conditions. EOG will monitor the well and ensure the well is static before casing operations begin.



Offline Production Cement Variance

EOG Offline Production Checklist

Offline Checklist

All items below must be met. If not, the production cement will be done online.

1. Offline production cement jobs **are applicable for the Base of the Wolfcamp or shallower.**
2. Nothing out of the ordinary observed during drilling, tripping, or casing running operations in the Production Hole Section.
3. Casing must be landed with Hanger.
4. EOG Company Man and Superintendent with Well Control certification must be present to monitor returns.
5. EOG Cement Advisor must be present to oversee the Cement Job.
6. Rig Manager is responsible for walking the rig to the next well.
7. The BOP will NOT be nipped down if:
 - a) ANY barrier fails to test.
 - b) ANY offset frac operations are observed within 1 mile and within the same producing horizon.
8. After all barriers test and the BLM has been notified, the BOP may be nipped down to proceed with offline operations.
9. EOG will not Drill out of the next well until Cement Operations have concluded on the offline well.

Offline Procedure

1. Run casing as per normal operations. Review EOG Offline Requirements Checklist, if the well is a candidate for Offline Cement on the Production continue following this procedure. Conduct negative pressure test while running casing and confirm integrity of the float equipment back pressure valves.
 - a. Float equipment is equipped with two back pressure valves rated to 15,000 psi.
2. Land production casing on mandrel hanger.
 - a. **If casing is unable to be landed with a mandrel hanger, then the casing will be cemented online.**
 - b. If utilizing a fluted/ported mandrel hanger, ensure well is static on the annulus and inside the casing by filling the pipe with kill weight fluid, remove landing joint, and set annular packoff rated to 10,000 psi. Pressure test same to 10,000 psi.
 - c. If utilizing a solid mandrel hanger, ensure well is static on the annulus and inside the casing by filling the pipe with kill weight fluid. Pressure test seals to 10,000 psi. Remove landing joint.
3. Install back pressure valve in the casing for a 3rd casing barrier.
 - a. Back pressure valve rated to a minimum of 10,000 psi.
4. With the well Secured and BLM notified; Nipple down BOP and secure on hydraulic carrier or cradle and Skid/Walk rig to next well on pad.
 - a. **Note, if any of the barriers fail to test, the BOP stack will not be nipped down until after the cement job has concluded.**
 - b. **Note, EOG Company Man and Cement Advisor will oversee Cementing Operations while Rig Manager walks the rig and nipples up the BOP.**
 - c. **Note, EOG will not drill out of the subsequent well until after plug bump.**
5. Install 10M Gate Valve, with Wellhead Adapter.
 - a. This creates an additional barrier on the annulus and inside the casing.
 - b. Gate valve rated to a minimum of 10,000 psi.
6. Test connection between Wellhead Adapter seals against hanger neck and ring gasket to 10,000 psi.
7. Remove backpressure valve from the casing.
8. Rig up cement head and cementing lines.
9. After rig up of cement head and cement lines, and confirmation of the annular barriers and casing barriers, notify the BLM with intent to proceed offline cementing.
10. Perform cement job.
11. *Note* – Procedure continued on the next page.

Offline Procedure

12. If an influx is noted during the Cement Job:
 - a. It is the Company Man and Superintendent's responsibility to maintain well control.
 - b. The aux manifold will be redirected to the rig's chokes.
 - c. Backpressure will be held on the well with the chokes to ensure well control is maintained through the remainder of the cement job while circulating out the influx.
 - d. If annular surface pressure approaches 90% tested pressure of the manifold or if circulating the influx out with the cementing pumps is not feasible, the well can be secured by closing the casing valves (10M).
 - e. Once cement is in place, we will close the casing valves and confirm the well is static and floats are holding.
 - f. If the floats fail, the gate valve (10M) or cement head (10M) can be closed to secure the well.
13. Confirm well is static and floats are holding after cement job.
14. Remove cement head.
15. Install back pressure valve.
16. Remove 10M Gate Valve and Wellhead Adapter.
17. Install night cap with pressure gauge for monitoring.
18. Test night cap to 5,000 psi.

Offline Barrier Overview

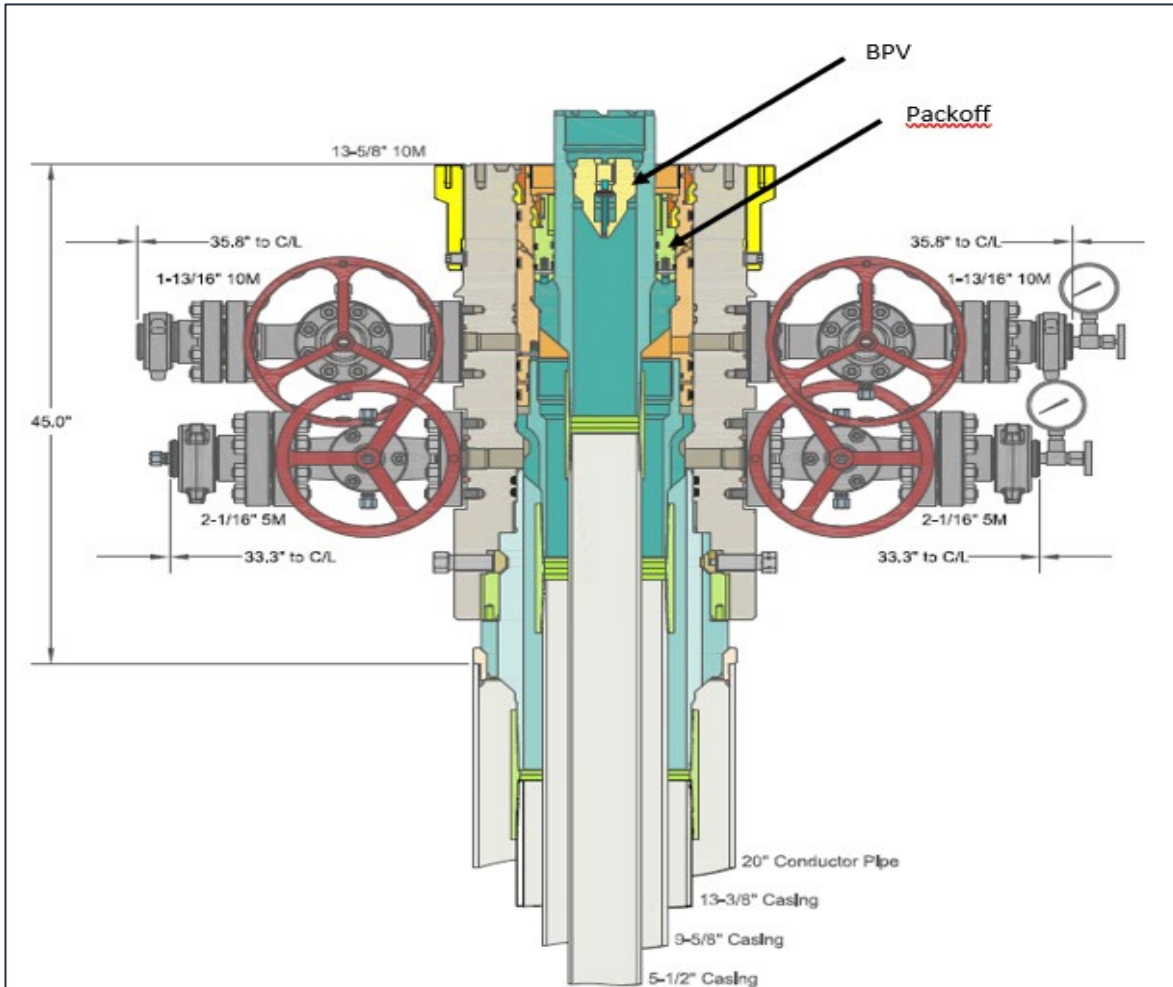

INFORMATION CONTAINED HEREIN IS THE PROPERTY OF CACTUS WELLHEAD, LLC. REPRODUCTION, DISCLOSURE, OR USE THEREOF IS PERMITTED ONLY AS PROVIDED BY CONTRACT OR AS EXPRESSLY AUTHORIZED BY CACTUS WELLHEAD, LLC.

ALL DIMENSIONS APPROXIMATE

CACTUS WELLHEAD LLC		EOG RESOURCES PERMIAN	
13-3/8" x 9-5/8" x 5-1/2" MBU-3T-CFL-DBLO-SF Wellhead System		DRAWN	DLE
And 13-3/8", 9-5/8" & 5-1/2" Pin Bottom Mandrel Casing Hangers		APPRV	28AUG19
		DRAWING NO.	SDT-2297-2

Barriers in Place during removal of BOP

Operation	Casing	Annulus
Nippling Down BOP	1. BPV 2. Hydrostatic Barrier 3. Float Valves	1. Hydrostatic Barrier 2. Mechanical 10M Packoff

Barriers in Place during Offline Cementing of Production Casing

Operation	Casing	Annulus
Pull BPV	1. Hydrostatic Barrier 2. Float Valves 3. 10M Gate Valve	1. Hydrostatic Barrier 2. Mechanical Packoff 3. 10M Wellhead Adapter
Install Cement Head	1. Hydrostatic Barrier 2. Float Valves 3. 10M Gate Valve	1. Hydrostatic Barrier 2. Mechanical 10M Packoff 3. 10M Wellhead Adapter
Cement Job	1. Hydrostatic Barrier 2. Float Valves 3. 10M Gate Valve 4. Cement Head	1. Hydrostatic Barrier 2. Mechanical 10M Packoff 3. 10M Wellhead Adapter
Remove Cement Head	1. Float Valves 2. 10M Gate Valve	1. Hydrostatic Barrier 2. Mechanical 10M Packoff 3. 10M Wellhead Adapter
Install BPV	1. Float Valves 2. 10M Gate Valve	1. Hydrostatic Barrier 2. Mechanical 10M Packoff 3. 10M Wellhead Adapter
Remove 10M Gate Valve	1. Float Valves 2. BPV	1. Hydrostatic Barrier 2. Mechanical 10M Packoff
Nipple Up TA Cap	1. Float Valves 2. BPV	1. Hydrostatic Barrier 2. Mechanical 10M Packoff

Offline Barrier Overview

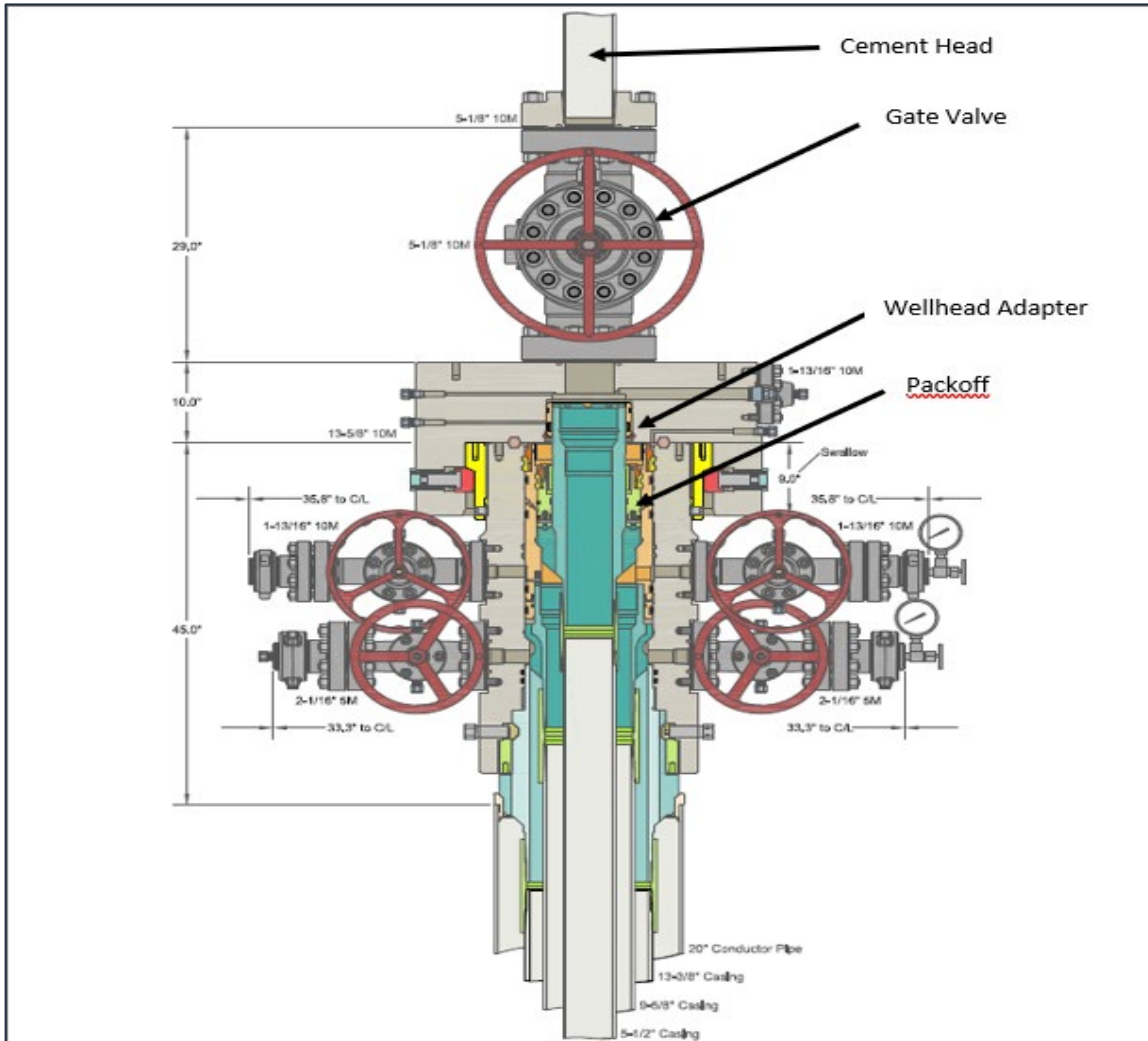

INFORMATION CONTAINED HEREIN IS THE PROPERTY OF CACTUS WELLHEAD, LLC. REPRODUCTION, DISCLOSURE, OR USE THEREOF IS PERMISSIBLE ONLY AS PROVIDED BY CONTRACT OR AS EXPRESSLY AUTHORIZED BY CACTUS WELLHEAD, LLC. ALL DIMENSIONS APPROXIMATE

CACTUS WELLHEAD LLC		EOG RESOURCES PERMIAN	
13-3/8" x 9-5/8" x 5-1/2" MBU-3T-CFL-DBLO-SF Wellhead System		DRAWN	DLE 28AUG19
Offline Cement Package		APPRV	
And 13-3/8", 9-5/8" & 5-1/2" Pin Bottom Mandrel Casing Hangers		DRAWING NO.	SDT-2297-3

Barriers in Place during removal of BOP		
Operation	Casing	Annulus
Nipling Down BOP	1. BPV 2. Hydrostatic Barrier 3. Float Valves	1. Hydrostatic Barrier 2. Mechanical 10M Packoff

Barriers in Place during Offline Cementing of Production Casing		
Operation	Casing	Annulus
Pull BPV	1. Hydrostatic Barrier 2. Float Valves 3. 10M Gate Valve	1. Hydrostatic Barrier 2. Mechanical Packoff 3. 10M Wellhead Adapter
Install Cement Head	1. Hydrostatic Barrier 2. Float Valves 3. 10M Gate Valve	1. Hydrostatic Barrier 2. Mechanical 10M Packoff 3. 10M Wellhead Adapter
Cement Job	1. Hydrostatic Barrier 2. Float Valves 3. 10M Gate Valve 4. Cement Head	1. Hydrostatic Barrier 2. Mechanical 10M Packoff 3. 10M Wellhead Adapter
Remove Cement Head	1. Float Valves 2. 10M Gate Valve	1. Hydrostatic Barrier 2. Mechanical 10M Packoff 3. 10M Wellhead Adapter
Install BPV	1. Float Valves 2. 10M Gate Valve	1. Hydrostatic Barrier 2. Mechanical 10M Packoff 3. 10M Wellhead Adapter
Remove 10M Gate Valve	1. Float Valves 2. BPV	1. Hydrostatic Barrier 2. Mechanical 10M Packoff
Nipple Up TA Cap	1. Float Valves 2. BPV	1. Hydrostatic Barrier 2. Mechanical 10M Packoff

More Control: Meeting/Exceeding Barrier Requirements

Casing Barriers – Online vs Offline		
Operation	Online	Offline
Install Cement Head	1. Hydrostatic Barrier 2. Float Valves	1. Hydrostatic Barrier 2. Float Valves 3. 10M Gate Valve
Cement Job	1. Hydrostatic Barrier 2. Float Valves 3. Cement Head	1. Hydrostatic Barrier 2. Float Valves 3. 10M Gate Valve 4. Cement Head
Remove Cement Head	1. Float Valves	1. Float Valves 2. 10M Gate Valve
Install BPV & Nipple Down BOP / Offline Adapter	1. Float Valves	1. Float Valves 2. BPV
Nipple Up TA Cap	1. Float Valves	1. Float Valves 2. BPV

Annulus Barriers – Online vs Offline		
Operation	Online	Offline
Install Cement Head	1. Hydrostatic Barrier 2. Annular 3. VBR	1. Hydrostatic Barrier 2. Mechanical Pack-off 3. 10M Wellhead Adapter
Cement Job	1. Hydrostatic Barrier 2. Annular 3. VBR	1. Hydrostatic Barrier 2. Mechanical Pack-off 3. 10M Wellhead Adapter
Remove Cement Head	1. Hydrostatic Barrier 2. Annular 3. VBR	1. Hydrostatic Barrier 2. Mechanical Pack-off 3. 10M Wellhead Adapter
Install BPV & Nipple Down BOP / Offline Adapter	1. Hydrostatic barrier 2. Mechanical Pack-off	1. Hydrostatic Barrier 2. Mechanical Pack-off
Nipple Up TA Cap	1. Hydrostatic barrier 2. Mechanical Pack-off	1. Hydrostatic Barrier 2. Mechanical Pack-off

Return Rig Up Diagram

Online

Offline

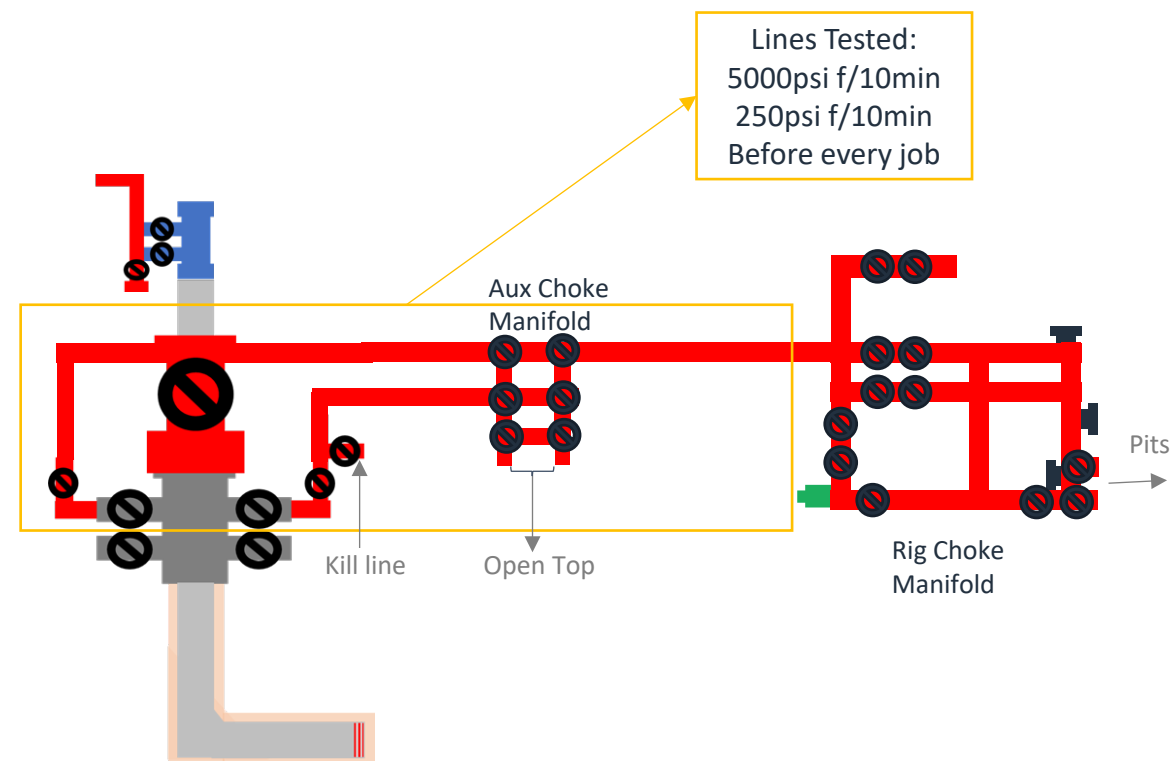
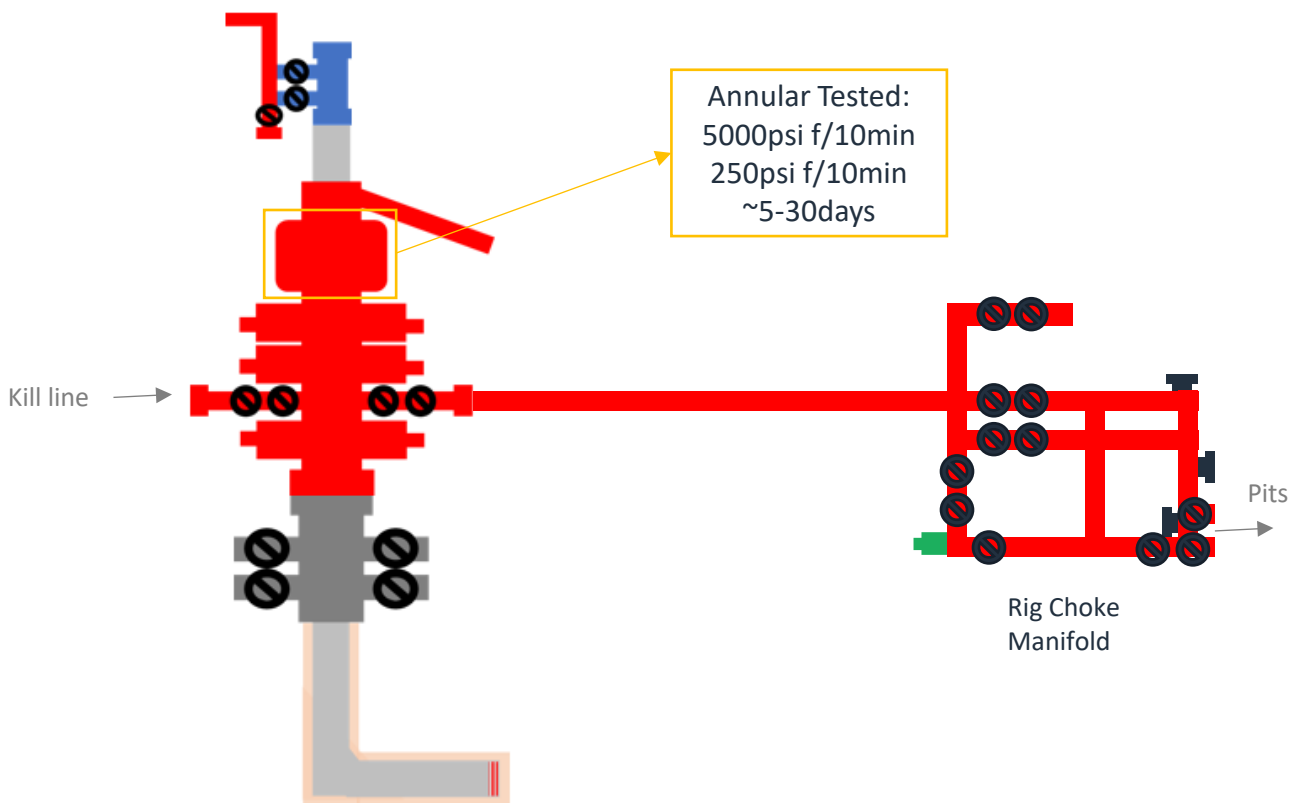

Note:

- 1) Have the Rig's same Well Control Capabilities as Online
- 2) Have more flexibility with Gate Valve than with a Landing Joint through BOP
- 3) Never had to circulate out a kick during Offline



Production Bradenhead Cement Variance

Production Bradenhead Cement

Shallow Target Production Offline Bradenhead:

EOG Resources Inc. (EOG) respectfully requests a variance from the minimum standards to allow for offline bradenhead cementing of the production string after primary cementing operations have been completed. The primary cement job will be pumped conventionally (online) to top of the Brushy Canyon and will cover the target production intervals, and after production pack-off is set and tested, bradenhead will be pumped through casing valves between the production and intermediate casings (offline). For the bradenhead stage of production cementing, the barriers remain the same for offline cementing compared to performing it online.

The bradenhead will be the primary option for production cementing. EOG also requests to have the conventional option in place to accommodate for logistical or wellbore conditions. The tie back requirements will be met if the cement is pumped conventionally, and cement volumes will be adjusted accordingly. TOC will be verified by CBL.



Salt Section Annular Clearance

Current Design (Salt Strings)

0.422" Annular clearance requirement

- Casing collars shall have a minimum clearance of 0.422 inches on all sides in the hole/casing annulus, with recognition that variances can be granted for justified exceptions.

- 12.25" Hole x 9.625" 40# J55/HCK55 LTC Casing
 - 1.3125" Clearance to casing OD
 - 0.8125" Clearance to coupling OD
- 9.875" Hole x 8.75" 38.5# P110 Sprint-SF Casing
 - 0.5625" Clearance to casing OD
 - 0.433" Clearance to coupling OD

Annular Clearance Variance Request

EOG request permission to allow deviation from the 0.422” annulus clearance requirement for the intermediate (salt) section from Onshore Order #2 under the following conditions:

- The variance is not applicable within the Potash Boundaries or Capitan Reef areas.
- Operator takes responsibility to get casing to set point in the event that the clearance causes stuck pipe issues

Volumetric Hole Size Calculation

Hole Size Calculations Off Cement Volumes

- Known volume of cement pumped
- Known volume of cement returned to surface
- Must not have had any losses
- Must have bumped plug

Average Hole Size

- 12.25" Hole
 - 12.88" Hole
 - 5.13% diameter increase
 - 10.52% area increase
 - 0.63" Average enlargement
 - 0.58" Median enlargement
 - 179 Well Count
- 9.875" Hole
 - 10.30" Hole
 - 4.24% diameter increase
 - 9.64% area increase
 - 0.42" Average enlargement
 - 0.46" Median enlargement
 - 11 Well Count

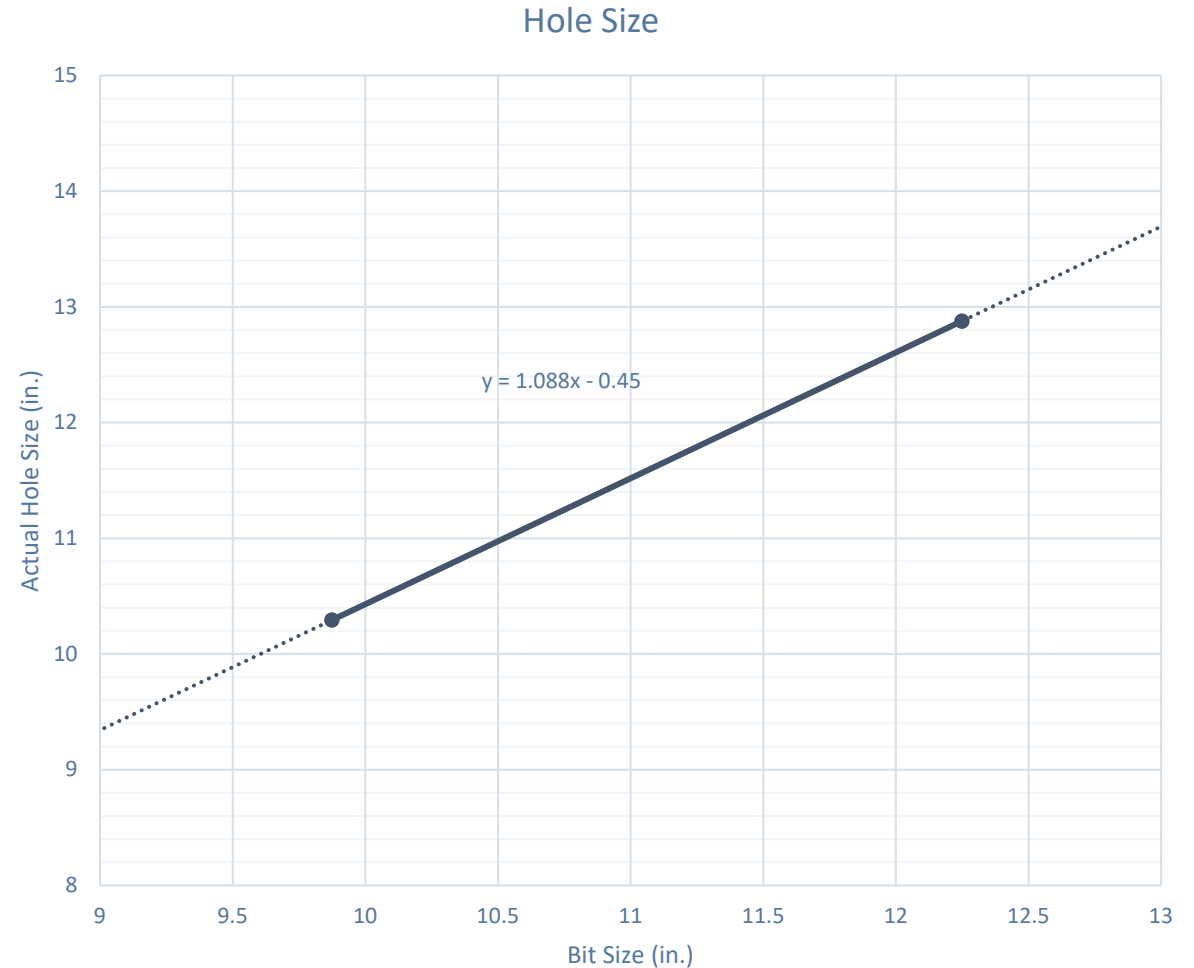

Caliper Hole Size (12.25")

Average Hole Size

- 12.25" Bit
 - 12.76" Hole
 - 4.14% diameter increase
 - 8.44% area increase
 - 0.51" Average enlargement
 - 0.52" Median enlargement
 - Brine

Modelo 10 Fed Com #501H

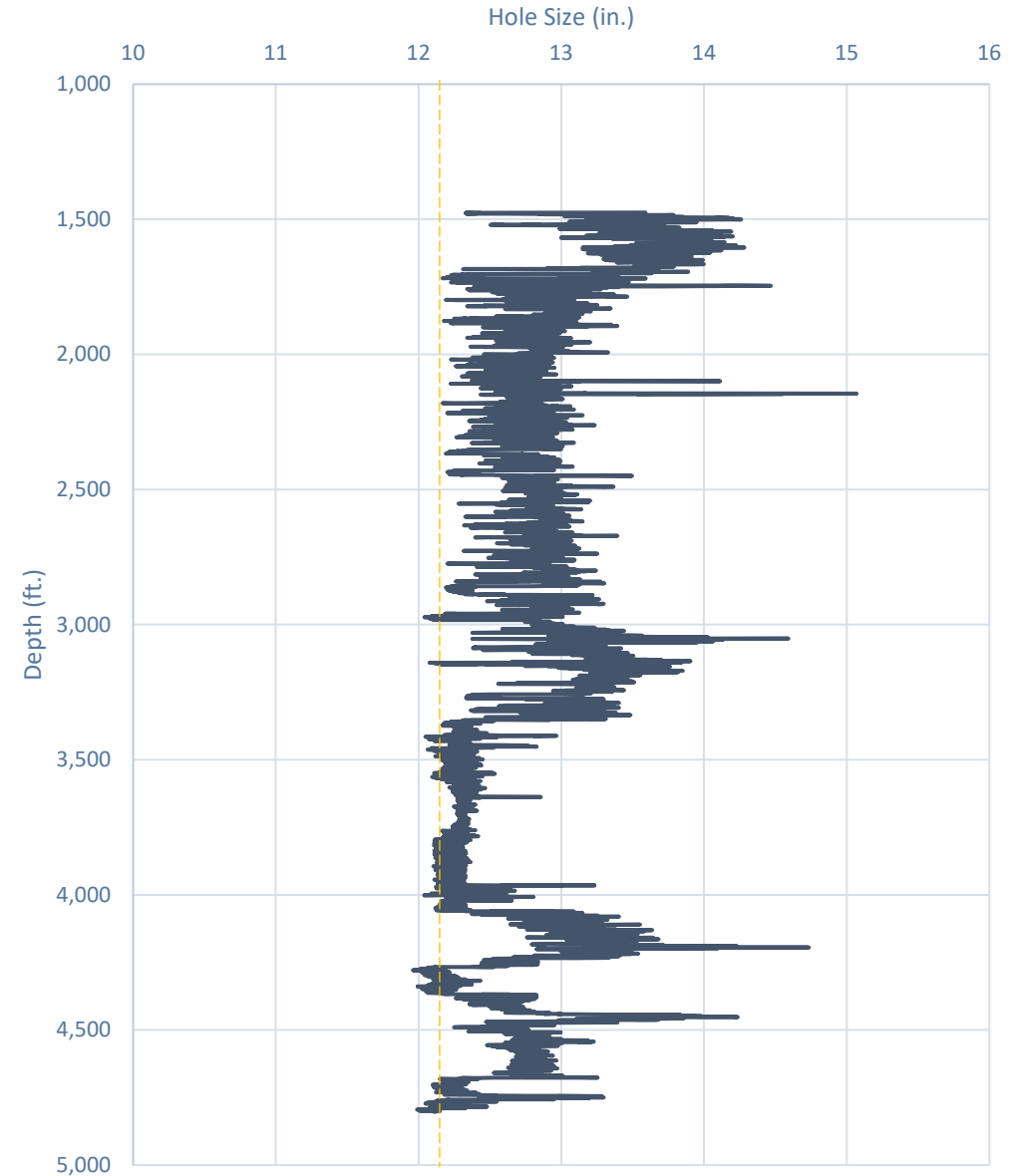

Caliper Hole Size (9.875")

Average Hole Size

- 9.875" Hole
 - 11.21" Hole
 - 13.54% diameter increase
 - 28.92% area increase
 - 1.33" Average enlargement
 - 1.30" Median enlargement
 - EnerLite

Whirling Wind 11 Fed Com #744H

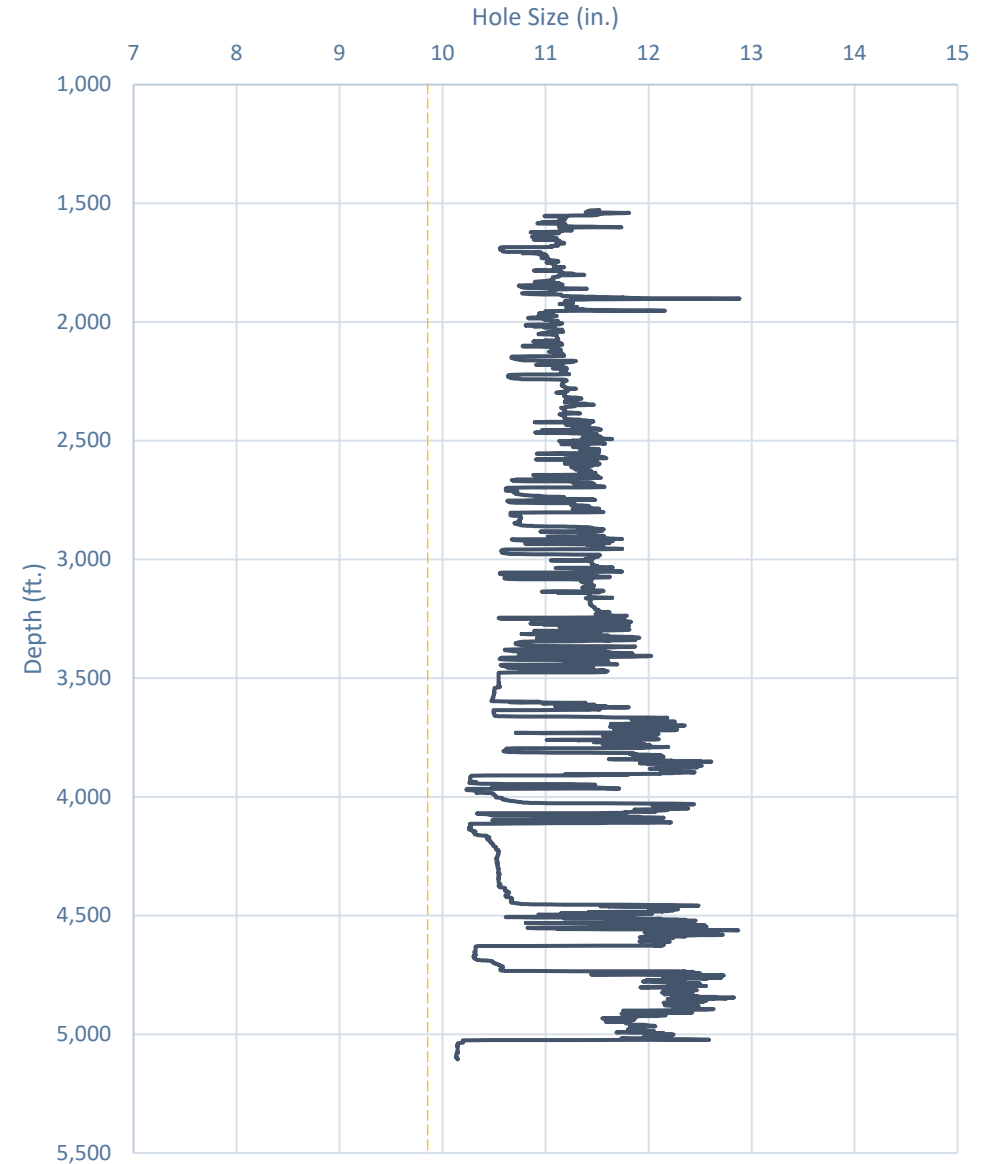

Design A

Proposed 11" Hole with 9.625" 40# J55/HCK55 LTC Casing

- 11" Bit + 0.52" Average hole enlargement = 11.52" Hole Size
 - 0.9475" Clearance to casing OD

$$= \frac{11.52 - 9.625}{2}$$
 - 0.4475" Clearance to coupling OD

$$= \frac{11.52 - 10.625}{2}$$
- Previous Shoe – 13.375" 54.5# J55 STC
 - 0.995" Clearance to coupling OD (~1,200' overlap)

$$= \frac{12.615 - 10.625}{2}$$

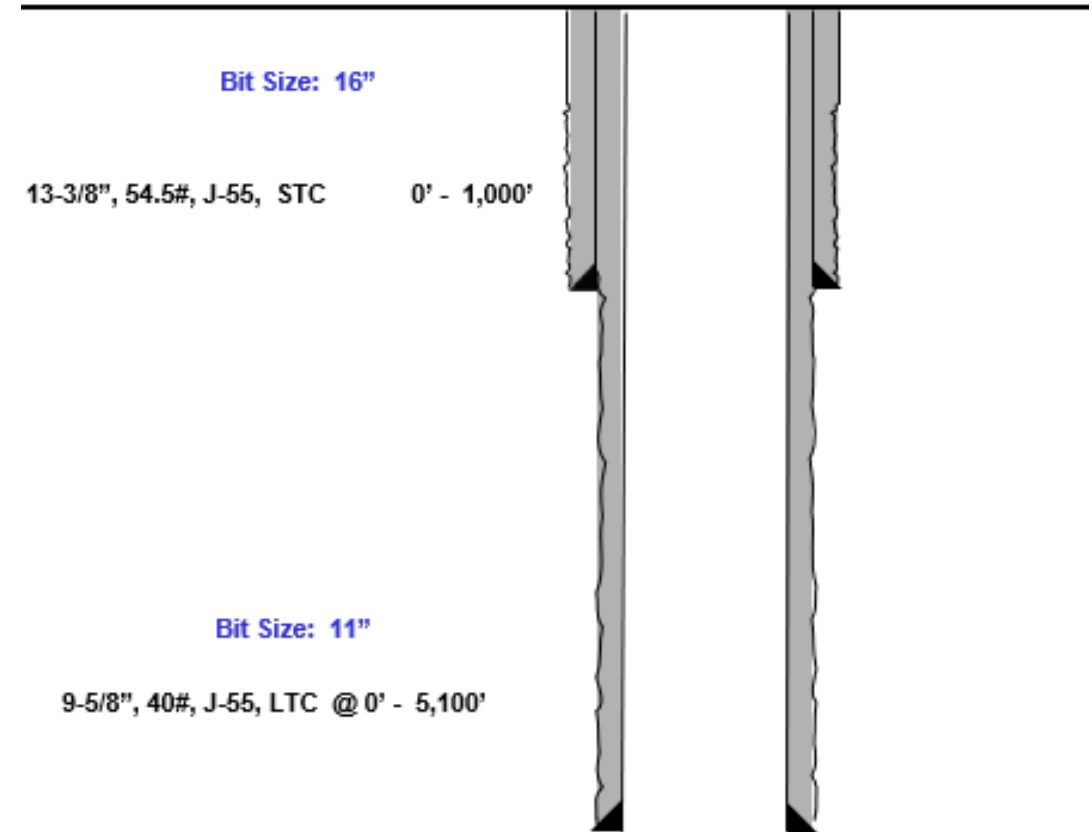

Design B

Proposed 9.875" Hole with 8.625" 32# J55/P110 BTC-SC Casing

- 9.875" Bit + 0.42" Average hole enlargement = 10.295" Hole Size
 - 0.835" Clearance to casing OD

$$= \frac{10.295 - 8.625}{2}$$
 - 0.585" Clearance to coupling OD

$$= \frac{10.295 - 9.125}{2}$$
- Previous Shoe – 10.75" 40.5# J55 STC
 - 0.4625" Clearance to coupling OD (~1,200' overlap)

$$= \frac{10.05 - 9.125}{2}$$

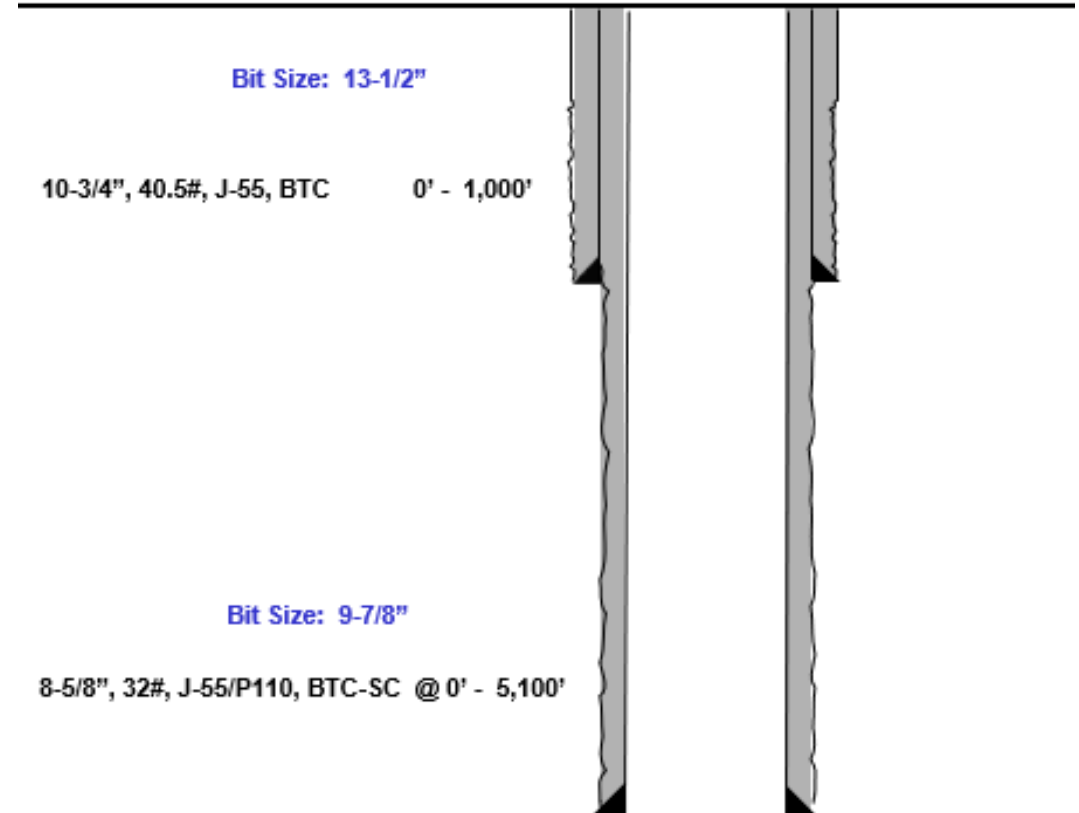



Index



Casing Spec Sheets

Pipe Body and API Connections Performance Data

10.750 40.50/0.350 J55

PDF

New Search »

« Back to Previous List

USC Metric

6/8/2015 10:14:05 AM

Mechanical Properties	Pipe	BTC	LTC	STC	
Minimum Yield Strength	55,000	--	--	--	psi
Maximum Yield Strength	80,000	--	--	--	psi
Minimum Tensile Strength	75,000	--	--	--	psi
Dimensions	Pipe	BTC	LTC	STC	
Outside Diameter	10.750	11.750	--	11.750	in.
Wall Thickness	0.350	--	--	--	in.
Inside Diameter	10.050	10.050	--	10.050	in.
Standard Drift	9.894	9.894	--	9.894	in.
Alternate Drift	--	--	--	--	in.
Nominal Linear Weight, T&C	40.50	--	--	--	lbs/ft
Plain End Weight	38.91	--	--	--	lbs/ft
Performance	Pipe	BTC	LTC	STC	
Minimum Collapse Pressure	1,580	1,580	--	1,580	psi
Minimum Internal Yield Pressure	3,130	3,130	--	3,130	psi
Minimum Pipe Body Yield Strength	629.00	--	--	--	1000 lbs
Joint Strength	--	700	--	420	1000 lbs
Reference Length	--	11,522	--	6,915	ft
Make-Up Data	Pipe	BTC	LTC	STC	
Make-Up Loss	--	4.81	--	3.50	in.
Minimum Make-Up Torque	--	--	--	3,150	ft-lbs
Maximum Make-Up Torque	--	--	--	5,250	ft-lbs



API 5CT, 10th Ed. Connection Data Sheet

O.D. (in)	WEIGHT (lb/ft)	WALL (in)	GRADE	*API DRIFT (in)	RBW %
8.625	Nominal: 32.00 Plain End: 31.13	0.352	J55	7.796	87.5

Material Properties (PE)

Pipe	
Minimum Yield Strength:	55 ksi
Maximum Yield Strength:	80 ksi
Minimum Tensile Strength:	75 ksi
Coupling	
Minimum Yield Strength:	55 ksi
Maximum Yield Strength:	80 ksi
Minimum Tensile Strength:	75 ksi

Pipe Body Data (PE)

Geometry	
Nominal ID:	7.92 inch
Nominal Area:	9.149 in ²
*Special/Alt. Drift:	7.875 inch
Performance	
Pipe Body Yield Strength:	503 kips
Collapse Resistance:	2,530 psi
Internal Yield Pressure: (API Historical)	3,930 psi

API Connection Data

Coupling OD: 9.625"

STC Performance

STC Internal Pressure:	3,930 psi
STC Joint Strength:	372 kips

LTC Performance

LTC Internal Pressure:	3,930 psi
LTC Joint Strength:	417 kips

SC-BTC Performance - Cplg OD = 9.125"

BTC Internal Pressure:	3,930 psi
BTC Joint Strength:	503 kips

API Connection Torque

STC Torque (ft-lbs)

Min:	2,793	Opti:	3,724	Max:	4,655
------	-------	-------	-------	------	-------

LTC Torque (ft-lbs)

Min:	3,130	Opti:	4,174	Max:	5,217
------	-------	-------	-------	------	-------

BTC Torque (ft-lbs)

follow API guidelines regarding positional make up

*Alt. Drift will be used unless API Drift is specified on order.

**If above API connections do not suit your needs, VAM® premium connections are available up to 100% of pipe body ratings.

ALL INFORMATION IS PROVIDED BY VALLOUREC OR ITS AFFILIATES AT USER'S SOLE RISK, WITHOUT LIABILITY FOR LOSS, DAMAGE OR INJURY RESULTING FROM THE USE THEREOF, AND ON AN "AS IS" BASIS WITHOUT WARRANTY OR REPRESENTATION OF ANY KIND, WHETHER EXPRESS OR IMPLIED, INCLUDING WITHOUT LIMITATION ANY WARRANTY OF MERCHANTABILITY, FITNESS FOR PURPOSE, ACCURACY OR COMPLETENESS. THE INFORMATION CONTAINED IN THIS DOCUMENT IS PROVIDED FOR INFORMATIONAL PURPOSES ONLY AND IS BASED ON ESTIMATES THAT HAVE NOT BEEN VERIFIED OR TESTED. IN NO EVENT SHALL VALLOUREC OR ITS AFFILIATES BE RESPONSIBLE FOR ANY INDIRECT, SPECIAL, INCIDENTAL, PUNITIVE, EXEMPLARY OR CONSEQUENTIAL LOSS OR DAMAGE (INCLUDING WITHOUT LIMITATION, LOSS OF USE, LOSS OF BARGAIN, LOSS OF REVENUE, PROFIT OR ANTICIPATED PROFIT) HOWEVER CAUSED OR ARISING, AND WHETHER SUCH LOSSES OR DAMAGES WERE FORESEEABLE OR VALLOUREC OR ITS AFFILIATES WERE ADVISED OF THE POSSIBILITY OF SUCH DAMAGES.

Rev 3, 7/30/2021

10/21/2022 15:24





Pegasus 3 Fed Com 324H

Revised Permit Information 07/25/2025:

Well Name: Pegasus 3 Fed Com 324H; FKA Pegasus 3 Fed Com 324H

Location: SHL: 1009' FSL & 1117' FWL, Section 3, T-24-S, R-32-E, LEA Co., N.M.

BHL: 100' FNL & 1870' FWL, Section 34, T-23-S, R-32-E, LEA Co., N.M.

1. CASING PROGRAM

Hole Size	Interval MD		Interval TVD		Csg OD	Weight	Grade	Conn
	From (ft)	To (ft)	From (ft)	To (ft)				
13"	0	1,272	0	1,272	10-3/4"	40.5#	J-55	STC
9-7/8"	0	5,109	0	4,960	8-5/8"	32#	J-55	BTC-SC
7-7/8"	0	9,580	0	9,442	6"	24.5#	P110-EC	VAM Sprint-TC
6-3/4"	9,580	20,258	9,442	9,919	5-1/2"	20#	P110-EC	VAM Sprint SF

**For highlighted rows above, variance is requested to run entire string of either 6" or 5-1/2" casing string above due to availability.

Variance is requested to waive the centralizer requirements for the 8-5/8" casing in the 9-7/8" hole size. An expansion additive will be utilized, in the cement slurry, for the entire length of the 9-7/8" hole interval to maximize cement bond and zonal isolation.

Variance is also requested to waive any centralizer requirements for the 6" and 5-1/2" casings in the 7-7/8" and 6-3/4" hole sizes. An expansion additive will be utilized, in the cement slurry, for the entire length of the 7-7/8" and 6-3/4" hole intervals to maximize cement bond and zonal isolation.

EOG requests permission to allow deviation from the 0.422" annulus clearance requirement for the intermediate (salt) section from Title 43 CFR Part 3170 under the following conditions:

- The variance is not applicable within the Potash Boundaries or Capitan Reef areas.
- Operator takes responsibility to get casing to set point in the event that the clearance causes stuck pipe issues.

2. CEMENTING PROGRAM:

Depth TVD	No. Sacks	Wt. ppg	Yld Ft3/sk	Slurry Description
1,272' 10-3/4"	290	13.5	1.73	Lead: Class C/H + additives (TOC @ Surface)
	120	14.8	1.34	Tail: Class C/H + additives (TOC @ 1080')
4,960' 8-5/8"	310	12.7	2.22	Lead: Class C/H + additives + expansion additives (TOC @ Surface)
	140	14.8	1.32	Tail: Class C/H + additives + expansion additives (TOC @ 4087')
20,258' 6" 5-1/2"	1000	14.8	1.32	Bradenhead squeeze: Class C/H + additives + expansion additives (TOC @ surface)
	1550	13.2	1.52	Tail: Class C/H + additives (TOC @ 7,128')



Pegasus 3 Fed Com 324H

Additive	Purpose
Bentonite Gel	Lightweight/Lost circulation prevention
Calcium Chloride	Accelerator
Cello-flake	Lost circulation prevention
Sodium Metasilicate	Accelerator
MagOx	Expansive agent
Pre-Mag-M	Expansive agent
Sodium Chloride	Accelerator
FL-62	Fluid loss control
Halad-344	Fluid loss control
Halad-9	Fluid loss control
HR-601	Retarder
Microbond	Expansive Agent

Cement integrity tests will be performed immediately following plug bump.

Note: Cement volumes based on bit size plus at least 25% excess in the open hole plus 10% excess in the cased-hole overlap section.

EOG requests variance from minimum standards to pump a two stage cement job on the 6" and 5-1/2" production casing strings with the first stage being pumped conventionally with the calculated top of cement at the Brushy Canyon (7,128') and the second stage performed as a 1000 sack bradenhead squeeze with planned cement from the Brushy Canyon to surface. If necessary, a top out consisting of 400 sacks of Class C/H cement + additives (1.32 yld, 14.8 ppg) will be executed as a contingency. Top will be verified by Echo-meter.

Bradenhead will be the primary option for production cementing. EOG also requests to have the conventional option in place to accommodate for logistical or wellbore conditions. The tie back requirements will be met if the cement is pumped conventionally, and cement volumes will be adjusted accordingly. TOC will be verified by CBL.

3. MUD PROGRAM:

Depth (TVD)	Type	Weight (ppg)	Viscosity	Water Loss
0 – 1,272'	Fresh - Gel	8.6-8.8	28-34	N/c
1,272' – 4,960'	Brine	9.8-10.8	28-34	N/c
4,960' – 20,258'	Oil Base	8.8-9.5	58-68	N/c - 6



Pegasus 3 Fed Com 324H

4. VARIANCE REQUESTS:

EOG requests the additional variances in the attached documents:

Variances requested include (supporting documents attached):

- BOP Break Testing Variance
- Offline Surface/Intermediate Cement Variance
- Offline Production Cement Variance
- Salt Section Annular Clearance Variance
- Alternate Shallow Casing Designs Variance



8. TUBING REQUIREMENTS:

EOG respectfully requests an exception to the following NMOCD rule:

- 19.15.16.10 Casing AND TUBING REQUIREMENTS:
J (3): “The operator shall set tubing as near the bottom as practical and tubing perforations shall not be more than 250 feet above top of pay zone.”

With horizontal flowing and gas lifted wells an end of tubing depth placed at or slightly above KOP is a conservative way to ensure the tubing stays clean from debris, plugging, and allows for fewer well interventions post offset completion. The deeper the tubulars are run into the curve, the higher the probability is that the tubing will become stuck in sand and or well debris as the well produces over time. An additional consideration for EOT placement during artificial lift installations is avoiding the high dog leg severity and inclinations found in the curve section of the wellbore to help improve reliability and performance. Dog leg severity and inclinations tend not to hamper gas lifted or flowing wells, but they do effect other forms of artificial lift like rod pump or ESP (electric submersible pump). Keeping the EOT above KOP is an industry best practice for those respective forms of artificial lift.



Pegasus 3 Fed Com 324H

1009' FSL
 1117' FWL
 Section 3
 T-24-S, R-32-E

Proposed Wellbore

API: 30-025-*****

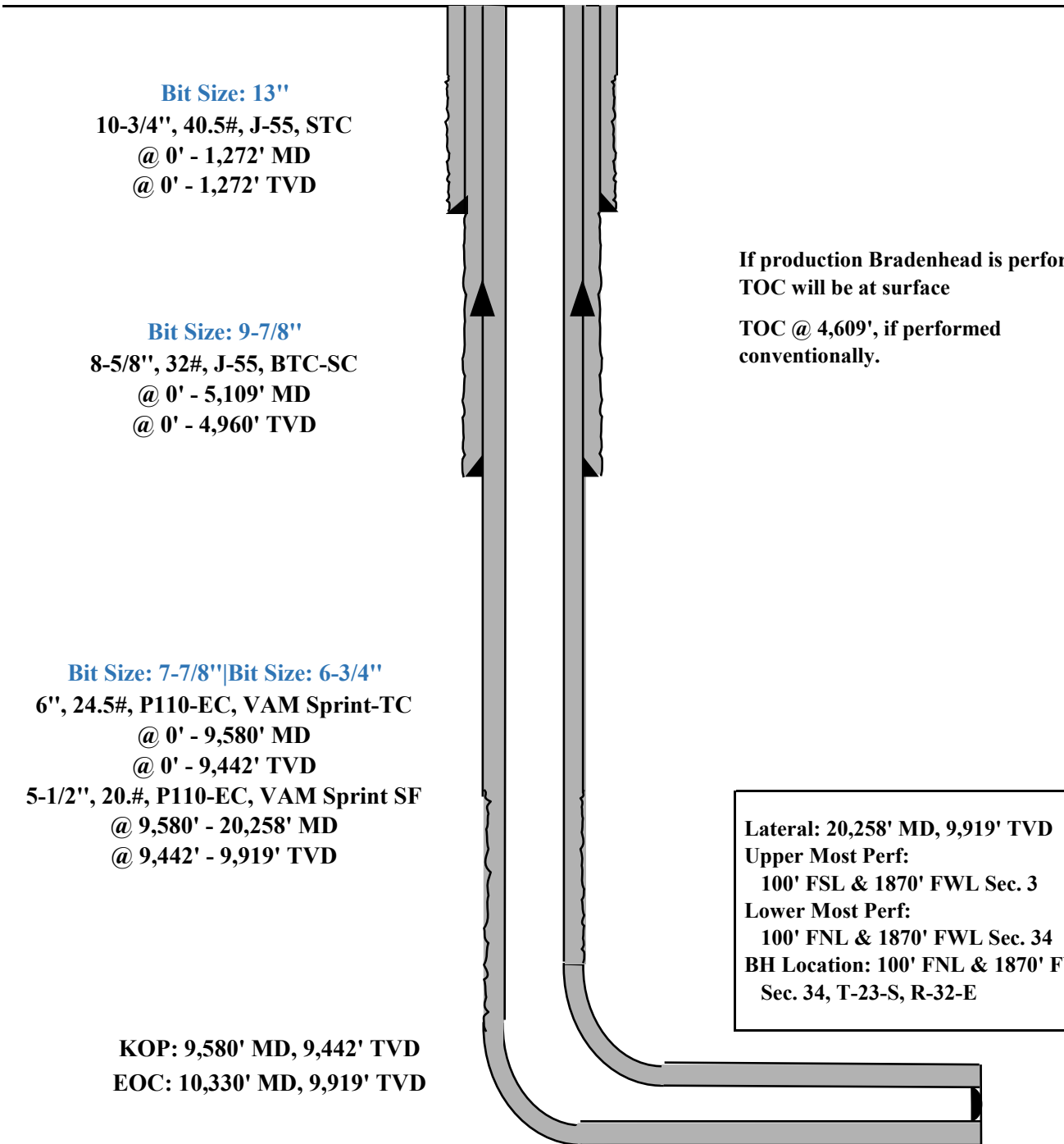
KB: 3680'
GL: 3655'



Bit Size: 13"
 10-3/4", 40.5#, J-55, STC
 @ 0' - 1,272' MD
 @ 0' - 1,272' TVD

Bit Size: 9-7/8"
 8-5/8", 32#, J-55, BTC-SC
 @ 0' - 5,109' MD
 @ 0' - 4,960' TVD

Bit Size: 7-7/8" | Bit Size: 6-3/4"
 6", 24.5#, P110-EC, VAM Sprint-TC
 @ 0' - 9,580' MD
 @ 0' - 9,442' TVD
 5-1/2", 20#, P110-EC, VAM Sprint SF
 @ 9,580' - 20,258' MD
 @ 9,442' - 9,919' TVD

KOP: 9,580' MD, 9,442' TVD
EOC: 10,330' MD, 9,919' TVD

If production Bradenhead is performed,
 TOC will be at surface

 TOC @ 4,609', if performed
 conventionally.

Lateral: 20,258' MD, 9,919' TVD
Upper Most Perf:
 100' FSL & 1870' FWL Sec. 3
Lower Most Perf:
 100' FNL & 1870' FWL Sec. 34
BH Location: 100' FNL & 1870' FWL
 Sec. 34, T-23-S, R-32-E



Pegasus 3 Fed Com 324H

1. GEOLOGIC NAME OF SURFACE FORMATION:

Permian

2. ESTIMATED TOPS OF IMPORTANT GEOLOGICAL MARKERS:

Rustler	1,178'
Tamarisk Anhydrite	1,247'
Top of Salt	1,479'
Base of Salt	4,682'
Lamar	4,910'
Bell Canyon	4,935'
Cherry Canyon	5,774'
Brushy Canyon	7,128'
Bone Spring Lime	8,755'
Leonard (Avalon) Shale	8,898'
1st Bone Spring Sand	9,920'
TD	9,919'

3. ESTIMATED DEPTHS OF ANTICIPATED FRESH WATER, OIL OR GAS:

Upper Permian Sands	0- 400'	Fresh Water
Lamar	4,910'	Oil
Cherry Canyon	5,774'	Oil
Brushy Canyon	7,128'	Oil
Bone Spring Lime	8,755'	Oil
Leonard (Avalon) Shale	8,898'	Oil
1st Bone Spring Sand	9,920'	Oil



Pegasus 3 Fed Com 324H API #: 30-025-*****

EOG respectfully requests an amendment to our approved APD for this well to reflect the following changes:

The original well Pegasus 3 Fed Com #324H (API: 30-025-54805) has been P&A'd (Sundry ID: 2865438). We request that the old well be renamed to Pegasus 3 Fed Com #324Y. The replacement well proposed will take the name Pegasus 3 Fed Com #324H. No new surface disturbance or pad expansion is required.

Reason for Skid: While drilling the 324H, the Pegasus 3 Fed Com 325H was potentially hit and the casing was breached/collapsed at 787'. Operations to get past the breach were unsuccessful, and there is communication between the wells of 6 BPM @ 100 psi. Decision was made to P&A both wells and redrill at new surfaces.

Sante Fe Main Office
Phone: (505) 476-3441

General Information
Phone: (505) 629-6116

Online Phone Directory
<https://www.emnrd.nm.gov/ocd/contact-us>

State of New Mexico
Energy, Minerals and Natural Resources
Oil Conservation Division
1220 S. St Francis Dr.
Santa Fe, NM 87505

CONDITIONS

Action 561062

CONDITIONS

Operator: EOG RESOURCES INC 5509 Champions Drive Midland, TX 79706	OGRID: 7377
	Action Number: 561062
	Action Type: [C-103] NOI Change of Plans (C-103A)

CONDITIONS

Created By	Condition	Condition Date
matthew.gomez	Well has been skid. Previous API # 30-025-54805. Current API # 30-025-54871.	3/9/2026
matthew.gomez	Notify the OCD 24 hours prior to casing & cement.	3/9/2026
matthew.gomez	Once the well is spud, to prevent ground water contamination through whole or partial conduits from the surface, the operator shall drill without interruption through the fresh water zone or zones and shall immediately set in cement the water protection string.	3/9/2026
matthew.gomez	Oil base muds are not to be used until fresh water zones are cased and cemented providing isolation from the oil or diesel. This includes synthetic oils. Oil based mud, drilling fluids and solids must be contained in a steel closed loop system.	3/9/2026
matthew.gomez	File As Drilled C-102 and a directional Survey with C-104 completion packet.	3/9/2026
matthew.gomez	If cement does not circulate to surface on any string, a Cement Bond Log (CBL) is required for that string of casing. If strata isolation is not achieved, remediation will be required before further operations may commence.	3/9/2026
matthew.gomez	All conducted logs must be submitted to the OCD.	3/9/2026
matthew.gomez	Cement must be in place for at least eight hours AND achieve a minimum compressive strength of 500 PSI before performing any further operations on the well.	3/9/2026
matthew.gomez	Cement is required to circulate on both surface and intermediate1 strings of casing.	3/9/2026