

<b>Well Name:</b> SUSAN LANCASTER FED COM	<b>Well Location:</b> T21S / R32E / SEC 7 / NENW / 32.4996282 / -103.7169903	<b>County or Parish/State:</b> LEA / NM
<b>Well Number:</b> 202H	<b>Type of Well:</b> OIL WELL	<b>Allottee or Tribe Name:</b>
<b>Lease Number:</b> NMNM131586	<b>Unit or CA Name:</b>	<b>Unit or CA Number:</b>
<b>US Well Number:</b>	<b>Operator:</b> MATADOR PRODUCTION COMPANY	

**Notice of Intent**

**Sundry ID:** 2894290

**Type of Submission:** Notice of Intent

**Type of Action:** APD Change

**Date Sundry Submitted:** 02/04/2026

**Time Sundry Submitted:** 08:13

**Date proposed operation will begin:** 02/11/2026

**Procedure Description:** BLM Bond No. NMB001079 Surety Bond No. RLB0015172 Matador requests the option to amend the well design of the Susan Lancaster Fed Com #202H and make the following changes to the current APD: - Change well SHL from 279' FNL & 1823' FWL section 7 to 279' FNL & 1683' FWL section 7. - Modify casing set depths as shown in the casing & cementing table. Cement volumes will be adjusted accordingly.

**NOI Attachments**

**Procedure Description**

- LO\_SUSAN\_LANCASTER\_FED\_COM\_202H\_REV2\_S\_Signed\_20260204080727.pdf
- Susan\_Lancaster\_Fed\_Com\_202H\_Directional\_Wall\_Plot\_20260204080712.pdf
- Susan\_Lancaster\_Fed\_Com\_202H\_Sundry\_Drill\_Plan\_20260204080711.pdf
- Susan\_Lancaster\_Fed\_Com\_202H\_Sundry\_Casing\_Table\_Spec\_20260204080711.pdf
- Susan\_Lancaster\_Fed\_Com\_202H\_Directional\_Well\_Plan\_20260204080711.pdf
- Susan\_Lancaster\_Fed\_Com\_202H\_Directional\_AC\_Report\_20260204080712.pdf

**Well Name:** SUSAN LANCASTER FED COM

**Well Location:** T21S / R32E / SEC 7 / NENW / 32.4996282 / -103.7169903

**County or Parish/State:** LEA / NM

**Well Number:** 202H

**Type of Well:** OIL WELL

**Allottee or Tribe Name:**

**Lease Number:** NMNM131586

**Unit or CA Name:**

**Unit or CA Number:**

**US Well Number:**

**Operator:** MATADOR PRODUCTION COMPANY

### Conditions of Approval

#### Additional

SUSAN\_LANCASTER\_FED\_COM\_202H\_Sundry\_2894290\_COA\_20260217105241.pdf

### Operator

*I certify that the foregoing is true and correct. Title 18 U.S.C. Section 1001 and Title 43 U.S.C. Section 1212, make it a crime for any person knowingly and willfully to make to any department or agency of the United States any false, fictitious or fraudulent statements or representations as to any matter within its jurisdiction. Electronic submission of Sundry Notices through this system satisfies regulations requiring a*

**Operator Electronic Signature:** ADDISON FISHER

**Signed on:** FEB 04, 2026 08:12 AM

**Name:** MATADOR PRODUCTION COMPANY

**Title:** Surface Land

**Street Address:** 5400 LBJ FREEWAY STE 1500

**City:** DALLAS

**State:** TX

**Phone:** (972) 371-5236

**Email address:** ADDISON.FISHER@MATADORRESOURCES.COM

### Field

**Representative Name:**

**Street Address:**

**City:**

**State:**

**Zip:**

**Phone:**

**Email address:**

### BLM Point of Contact

**BLM POC Name:** CHRISTOPHER WALLS

**BLM POC Title:** Petroleum Engineer

**BLM POC Phone:** 5752342234

**BLM POC Email Address:** CWALLS@BLM.GOV

**Disposition:** Approved

**Disposition Date:** 02/20/2026

**Signature:** Chris Walls

Form 3160-5  
(October 2024)

UNITED STATES  
DEPARTMENT OF THE INTERIOR  
BUREAU OF LAND MANAGEMENT

FORM APPROVED  
OMB No. 1004-0220  
Expires: October 31, 2027

**SUNDRY NOTICES AND REPORTS ON WELLS**  
**Do not use this form for proposals to drill or to re-enter an abandoned well. Use Form 3160-3 (APD) for such proposals.**

<b>SUBMIT IN TRIPLICATE - Other instructions on page 2</b>		5. Lease Serial No.
1. Type of Well <input type="checkbox"/> Oil Well <input type="checkbox"/> Gas Well <input type="checkbox"/> Other		6. If Indian, Allottee or Tribe Name
2. Name of Operator		7. If Unit of CA/Agreement, Name and/or No.
3a. Address	3b. Phone No. (include area code)	8. Well Name and No.
4. Location of Well (Footage, Sec., T.,R.,M., or Survey Description)		9. API Well No.
		10. Field and Pool or Exploratory Area
		11. Country or Parish, State

12. CHECK THE APPROPRIATE BOX(ES) TO INDICATE NATURE OF NOTICE, REPORT OR OTHER DATA

TYPE OF SUBMISSION	TYPE OF ACTION			
<input type="checkbox"/> Notice of Intent	<input type="checkbox"/> Acidize	<input type="checkbox"/> Deepen	<input type="checkbox"/> Production (Start/Resume)	<input type="checkbox"/> Water Shut-Off
<input type="checkbox"/> Subsequent Report	<input type="checkbox"/> Alter Casing	<input type="checkbox"/> Hydraulic Fracturing	<input type="checkbox"/> Reclamation	<input type="checkbox"/> Well Integrity
<input type="checkbox"/> Final Abandonment Notice	<input type="checkbox"/> Casing Repair	<input type="checkbox"/> New Construction	<input type="checkbox"/> Recomplete	<input type="checkbox"/> Other
	<input type="checkbox"/> Change Plans	<input type="checkbox"/> Plug and Abandon	<input type="checkbox"/> Temporarily Abandon	
	<input type="checkbox"/> Convert to Injection	<input type="checkbox"/> Plug Back	<input type="checkbox"/> Water Disposal	

13. Describe Proposed or Completed Operation: Clearly state all pertinent details, including estimated starting date of any proposed work and approximate duration thereof. If the proposal is to deepen directionally or recomplete horizontally, give subsurface locations and measured and true vertical depths of all pertinent markers and zones. Attach the Bond under which the work will be performed or provide the Bond No. on file with BLM/BIA. Required subsequent reports must be filed within 30 days following completion of the involved operations. If the operation results in a multiple completion or recompletion in a new interval, a Form 3160-4 must be filed once testing has been completed. Final Abandonment Notices must be filed only after all requirements, including reclamation, have been completed and the operator has determined that the site is ready for final inspection.)

14. I hereby certify that the foregoing is true and correct. Name (Printed/Typed)		
	Title	
Signature	Date	

**THE SPACE FOR FEDERAL OR STATE OFFICE USE**

Approved by		
	Title	Date
Conditions of approval, if any, are attached. Approval of this notice does not warrant or certify that the applicant holds legal or equitable title to those rights in the subject lease which would entitle the applicant to conduct operations thereon.	Office	

Title 18 U.S.C Section 1001 and Title 43 U.S.C Section 1212, make it a crime for any person knowingly and willfully to make to any department or agency of the United States any false, fictitious or fraudulent statements or representations as to any matter within its jurisdiction.

(Instructions on page 2)

## GENERAL INSTRUCTIONS

This form is designed for submitting proposals to perform certain well operations and reports of such operations when completed as indicated on Federal and Indian lands pursuant to applicable Federal law and regulations. Any necessary special instructions concerning the use of this form and the number of copies to be submitted, particularly with regard to local area or regional procedures and practices, are either shown below, will be issued by or may be obtained from the local Federal office.

## SPECIFIC INSTRUCTIONS

*Item 4* - Locations on Federal or Indian land should be described in accordance with Federal requirements. Consult the local Federal office for specific instructions.

*Item 13*: Proposals to abandon a well and subsequent reports of abandonment should include such special information as is required by the local Federal office. In addition, such proposals and reports should include reasons for the abandonment; data on any former or present productive zones or other zones with present significant fluid contents not sealed off by cement or otherwise; depths (top and bottom) and method of placement of cement plugs; mud or other material placed below, between and above plugs; amount, size, method of parting of any casing, liner or tubing pulled and the depth to the top of any tubing left in the hole; method of closing top of well and date well site conditioned for final inspection looking for approval of the abandonment. If the proposal will involve **hydraulic fracturing operations**, you must comply with 43 CFR 3162.3-3, including providing information about the protection of usable water. Operators should provide the best available information about all formations containing water and their depths. This information could include data and interpretation of resistivity logs run on nearby wells. Information may also be obtained from state or tribal regulatory agencies and from local BLM offices.

## NOTICES

The privacy Act of 1974 and the regulation in 43 CFR 2.48(d) provide that you be furnished the following information in connection with information required by this application.

AUTHORITY: 30 U.S.C. 181 et seq., 351 et seq., 25 U.S.C. 396; 43 CFR 3160.

PRINCIPAL PURPOSE: The information is used to: (1) Evaluate, when appropriate, approve applications, and report completion of subsequent well operations, on a Federal or Indian lease; and (2) document for administrative use, information for the management, disposal and use of National Resource lands and resources, such as: (a) evaluating the equipment and procedures to be used during a proposed subsequent well operation and reviewing the completed well operations for compliance with the approved plan; (b) requesting and granting approval to perform those actions covered by 43 CFR 3162.3-2, 3162.3-3, and 3162.3-4; (c) reporting the beginning or resumption of production, as required by 43 CFR 3162.4-1(c) and (d) analyzing future applications to drill or modify operations in light of data obtained and methods used.

ROUTINE USES: Information from the record and/or the record will be transferred to appropriate Federal, State, local or foreign agencies, when relevant to civil, criminal or regulatory investigations or prosecutions in connection with congressional inquiries or to consumer reporting agencies to facilitate collection of debts owed the Government.

EFFECT OF NOT PROVIDING THE INFORMATION: Filing of this notice and report and disclosure of the information is mandatory for those subsequent well operations specified in 43 CFR 3162.3-2, 3162.3-3, 3162.3-4.

The Paperwork Reduction Act of 1995 requires us to inform you that:

The BLM collects this information to evaluate proposed and/or completed subsequent well operations on Federal or Indian oil and gas leases.

Response to this request is mandatory.

The BLM would like you to know that you do not have to respond to this or any other Federal agency-sponsored information collection unless it displays a currently valid OMB control number.

**BURDEN HOURS STATEMENT:** Public reporting burden for this form is estimated to average 8 hours per response, including the time for reviewing instructions, gathering and maintaining data, and completing and reviewing the form. Direct comments regarding the burden estimate or any other aspect of this form to U.S. Department of the Interior, Bureau of Land Management (1004-0137), Bureau Information Collection Clearance Officer (WO-630), 1849 C St., N.W., Mail Stop 401 LS, Washington, D.C. 20240

## Additional Information

### Location of Well

0. SHL: NENW / 279 FNL / 1823 FWL / TWSP: 21S / RANGE: 32E / SECTION: 7 / LAT: 32.4996282 / LONG: -103.7169903 ( TVD: 0 feet, MD: 0 feet )  
PPP: LOT 18 / 100 FSL / 1086 FWL / TWSP: 21S / RANGE: 32E / SECTION: 6 / LAT: 32.5006604 / LONG: -103.7193796 ( TVD: 11559 feet, MD: 11918 feet )  
PPP: LOT 5 / 2718 FNL / 1082 FWL / TWSP: 21S / RANGE: 32E / SECTION: 6 / LAT: 32.514903 / LONG: -103.7193883 ( TVD: 11560 feet, MD: 17099 feet )  
PPP: LOT 4 / 0 FSL / 993 FWL / TWSP: 21S / RANGE: 32E / SECTION: 6 / LAT: 32.5223744 / LONG: -103.7208107 ( TVD: 11562 feet, MD: 19864 feet )  
BHL: NESW / 2527 FSL / 2315 FWL / TWSP: 20S / RANGE: 32E / SECTION: 36 / LAT: 32.5293191 / LONG: -103.7208073 ( TVD: 11562 feet, MD: 22391 feet )

CONFIDENTIAL

## PECOS DISTRICT DRILLING CONDITIONS OF APPROVAL

<b>OPERATOR'S NAME:</b>	MATADOR PRODUCTION COMPANY
<b>WELL NAME &amp; NO.:</b>	SUSAN LANCASTER FED COM 202H
<b>APD ID:</b>	10400107173
<b>LOCATION:</b>	Section 7, T21S, R32E. NMP.
<b>COUNTY:</b>	<input type="text" value="Lea County, New Mexico"/>

COA

H <sub>2</sub> S	<input type="radio"/> No		<input checked="" type="radio"/> Yes	
<b>Potash / WIPP</b>	<input type="radio"/> None	<input type="radio"/> Secretary	<input checked="" type="radio"/> R-111-Q	<input checked="" type="checkbox"/> Open Annulus
	4-String Design: Open 2nd Int x Production Casing (ICP 2 above Relief Zone)			<input type="checkbox"/> WIPP
<b>Cave / Karst</b>	<input checked="" type="radio"/> Low	<input type="radio"/> Medium	<input type="radio"/> High	<input type="radio"/> Critical
<b>Wellhead</b>	<input type="radio"/> Conventional	<input checked="" type="radio"/> Multibowl	<input type="radio"/> Both	<input type="radio"/> Diverter
<b>Cementing</b>	<input checked="" type="checkbox"/> Primary Squeeze	<input type="checkbox"/> Cont. Squeeze	<input type="checkbox"/> EchoMeter	<input checked="" type="checkbox"/> DV Tool
<b>Special Req</b>	<input checked="" type="checkbox"/> Capitan Reef	<input type="checkbox"/> Water Disposal	<input checked="" type="checkbox"/> COM	<input type="checkbox"/> Unit
<b>Waste Prev.</b>	<input type="radio"/> Self-Certification	<input checked="" type="radio"/> Waste Min. Plan	<input type="radio"/> APD Submitted prior to 06/10/2024	
<b>Additional Language</b>	<input checked="" type="checkbox"/> Flex Hose	<input type="checkbox"/> Casing Clearance	<input type="checkbox"/> Pilot Hole	<input checked="" type="checkbox"/> Break Testing
	<input checked="" type="checkbox"/> Four-String	<input checked="" type="checkbox"/> Offline Cementing	<input type="checkbox"/> Fluid-Filled	

**SEE ORIGINAL COA FOR ALL OTHER REQUIREMENTS.**

*APD is within the R-111-Q defined boundary. Operator must follow all applicable procedures and requirements listed within the Order No. R-111-Q.*

### A. CASING PROGRAM

1. The **13-3/8 -inch** surface casing shall be set at approximately **1,115 ft.** (a minimum of 70 feet into the Rustler Anhydrite, above the salt, and below usable fresh water) and cemented to the surface. **If salt is encountered, set casing at least 25 ft. above the salt.**
  - a. If cement does not circulate to the surface, the appropriate BLM office shall be notified and a temperature survey utilizing an electronic-type temperature survey with surface log readout will be used or a cement bond log shall be run to verify the top of the cement. Temperature survey will be run a minimum of six hours after pumping cement and ideally between 8-10 hours after completing the cement job.
  - b. Wait on cement (WOC) time for a primary cement job will be a minimum of **8 hours** or **500 psi compressive strength**, whichever is greater. (This is to include the lead cement)
  - c. Wait on cement (WOC) time for a remedial job will be a minimum of 4 hours after bringing cement to surface or 500 pounds compressive strength, whichever is greater.
  - d. If cement falls back, remedial cementing will be done prior to drilling out that string.

**Note:** Operator has requested to have option to drill either 17-1/2” or 20” surface hole. Both hole sizes meet title 43 CFR 3172 clearance requirements between casing-coupling and hole. This option is granted; adjust cement volume accordingly.

2. The **10-3/4 inch** 1<sup>st</sup> intermediate casing shall be set in a competent bed at approximately **3,016 ft.** The minimum required fill of cement behind the **10-3/4 inch** intermediate casing is:

**Option 1 (Single Stage): Cement to surface.** If cement does not circulate see B.1.a, c-d above. Wait on cement (WOC) time for a primary cement job is to include the lead cement slurry due to **Capitan Reef, and Potash.**

**Option 2 (Two-Stage):** The operator has proposed to utilize a DV tool. Operator may adjust depth of DV tool if needed, adjust cement volumes accordingly. The DV tool may be cancelled if cement circulates to surface on the first stage.

- a. **First stage to DV tool:** Cement to circulate. If cement does not circulate off the DV tool, contact the appropriate BLM office before proceeding with 2<sup>nd</sup> stage cement job.
  - b. **Second stage above DV tool: Cement to surface.** If cement does not circulate see B.1.a, c-d above. Wait on cement (WOC) time for a primary cement job is to include the lead cement slurry due to **Capitan Reef, and Potash.** Excess cement for the 2<sup>nd</sup> stage is below %25. More cement might be needed.
3. The **8-5/8-inch** 2<sup>nd</sup> intermediate casing shall be set in a competent bed at approximately **5,106 ft.** (5,100 ft. TVD). The minimum required fill of cement behind the **8-5/8-inch** intermediate casing is:

**Option 1 (Single Stage): Cement to surface.** If cement does not circulate see B.1.a, c-d above. Wait on cement (WOC) time for a primary cement job is to include the lead cement slurry due to **Capitan Reef, and Potash.**

**Option 2 (Two-Stage):** The operator has proposed to utilize a DV tool. Operator may adjust depth of DV tool if needed, adjust cement volumes accordingly. The DV tool may be cancelled if cement circulates to surface on the first stage.

- a. **First stage to DV tool:** Cement to circulate. If cement does not circulate off the DV tool, contact the appropriate BLM office before proceeding with second stage cement job.
- b. **Second stage above DV tool: Cement to surface.** If cement does not circulate see B.1.a, c-d above. Wait on cement (WOC) time for a primary cement job is to include the lead cement slurry due to **Capitan Reef, and Potash.** Excess cement for the 2<sup>nd</sup> stage is below %25. More cement might be needed.

4. Operator has proposed to set **5-1/2** inch production casing at approximately **22,392 ft.** (11,562 ft. TVD). The minimum required fill of cement behind the **5-1/2** inch production casing is:
- Operator has proposed to cement the production casing in two stages by conventionally cementing the first stage and performing a bradenhead squeeze on the second stage within 180 days after well completion in accordance with the R-111-Q guidelines.
    - a. First stage: Operator will cement production casing with intent to bring cement to top of Brushy Canyon formation.
    - b. Second stage: Operator will perform bradenhead squeeze within 180 days after completion per R-111-Q requirements. Cement shall be tie-back **at least 500 ft. into the 2<sup>nd</sup> intermediate casing and below the Marker Bed 126.** If cement does not circulate, the appropriate BLM office shall be notified.
  - ❖ Operator has proposed an open annulus completion in R-111-Q. Operator shall provide a method of verification pre-completion top of cement. **Submit results to the BLM.**
  - ❖ **Operator must verify top of cement per R-111-Q requirements.** Submit results to the BLM. If cement does not circulate, contact the appropriate BLM office. If cement does not tie-back at least 500 ft. into the previous casing shoe, the appropriate BLM office shall be notified.
  - ❖ A monitored open annulus will be incorporated during completion by leaving the 2<sup>nd</sup> Intermediate Casing x Production Casing annulus un-cemented and monitored. Operator must follow **all** monitoring requirements listed within R-111-Q. Tieback shall be met within **180 days.**
  - ❖ **In the event of a casing failure during completion,** the operator must contact the BLM engineer at (575-706-2779) and inspection staff (575-393-3612 Lea County).

**Note:** Operator has requested the option to drill 6.75" production hole from KOP to TD. This option is granted. Adjust cement volume accordingly.

### Offline Cementing

Operator has been (**Approved**) to pump the proposed cement program offline in the **Surface and intermediate(s) intervals.** Offline cementing should commence within 24 hours of landing the casing for the interval. Notify the BLM 4hrs prior to the commencement of any offline cementing procedure at **Lea County: 575-689-5981.**

## GENERAL REQUIREMENTS

The BLM is to be notified in advance for a representative to witness:

- a. Spudding well (minimum of 24 hours)
- b. Setting and/or Cementing of all casing strings (minimum of 4 hours)

- c. BOPE tests (minimum of 4 hours)

**Contact Lea County Petroleum Engineering Inspection Staff:**

Call the Hobbs Field Station, 414 West Taylor, Hobbs NM 88240, (575) 689-5981.

1. Unless the production casing has been run and cemented or the well has been properly plugged, the drilling rig shall not be removed from over the hole without prior approval.
  - a. In the event the operator has proposed to drill multiple wells utilizing a skid/walking rig. Operator shall secure the wellbore on the current well, after installing and testing the wellhead, by installing a blind flange of like pressure rating to the wellhead and a pressure gauge that can be monitored while drilling is performed on the other well(s).
  - b. When the operator proposes to set surface casing with Spudder Rig
    - i. Notify the BLM when moving in and removing the Spudder Rig.
    - ii. Notify the BLM when moving in the 2<sup>nd</sup> Rig. Rig to be moved in within 90 days of notification that Spudder Rig has left the location.
    - iii. BOP/BOPE test to be conducted per **43 CFR 3172** as soon as 2<sup>nd</sup> Rig is rigged up on well.
2. Floor controls are required for 3M or Greater systems. These controls will be on the rig floor, unobstructed, readily accessible to the driller and will be operational at all times during drilling and/or completion activities. Rig floor is defined as the area immediately around the rotary table; the area immediately above the substructure on which the draw works are located, this does not include the doghouse or stairway area.
3. For intervals in which cement to surface is required, cement to surface should be verified with a visual check and density or pH check to differentiate cement from spacer and drilling mud. The results should be documented in the driller's log and daily reports.

**A. CASING & CEMENTING**

1. The current acceptable methods of cement verification are as follows:
  - i. Observing cement circulated to surface,
  - ii. Cement Bond Log (CBL),
  - iii. Temperature log within 8-10 hours after completing the cement job,
  - iv. Echometer (if a second-stage bradenhead is being utilized and operator was granted approval prior to operations.)
2. Changes to the approved APD casing program need prior approval if the items substituted are of lesser grade or different casing size or are Non-API. The Operator can exchange the components of the proposal with that of superior strength (i.e. changing from J-55 to N-80, or from 36# to 40#). Changes to the approved cement program need prior approval if the altered cement plan has less volume or strength or if the changes are substantial (i.e. Multistage tool, ECP, etc.). The initial wellhead installed on the well will remain on the well with spools used as needed.

3. Wait on cement (WOC) for Potash Areas: After cementing but before commencing any tests, the casing string shall stand cemented under pressure until both of the following conditions have been met: 1) cement reaches a minimum compressive strength of 500 psi for all cement blends of both lead and tail cement, 2) until cement has been in place at least 8 hours. WOC time will be recorded in the driller's log. The casing integrity test can be done (prior to the cement setting up) immediately after bumping the plug.
4. Wait on cement (WOC) for Water Basin: After cementing but before commencing any tests, the casing string shall stand cemented under pressure until both of the following conditions have been met: 1) cement reaches a minimum compressive strength of 500 psi at the shoe, 2) until cement has been in place at least 8 hours. WOC time will be recorded in the driller's log. See individual casing strings for details regarding lead cement slurry requirements. The casing integrity test can be done (prior to the cement setting up) immediately after bumping the plug.
5. Provide compressive strengths including hours to reach required 500 pounds compressive strength prior to cementing each casing string. Have well specific cement details onsite prior to pumping the cement for each casing string.
6. No pea gravel permitted for remedial or fall back remedial without prior authorization from the BLM engineer.
7. On that portion of any well approved for a 5M BOPE system or greater, a pressure integrity test of each casing shoe shall be performed. Formation at the shoe shall be tested to a minimum of the mud weight equivalent anticipated to control the formation pressure to the next casing depth or at total depth of the well. This test shall be performed before drilling more than 20 feet of new hole.
8. If hardband drill pipe is rotated inside casing, returns will be monitored for metal. If metal is found in samples, drill pipe will be pulled and rubber protectors which have a larger diameter than the tool joints of the drill pipe will be installed prior to continuing drilling operations.
9. Whenever a casing string is cemented in the R-111-Q potash area, the NMOCD requirements shall be followed.

## **B. PRESSURE CONTROL**

1. All blowout preventer (BOP) and related equipment (BOPE) shall comply with well control requirements as described in **43 CFR 3172**.
2. If a variance is approved for a flexible hose to be installed from the BOP to the choke manifold, the following requirements apply: The flex line must meet the requirements of API 16C. Check condition of flexible line from BOP to choke manifold, replace if exterior is damaged or if line fails test. Line to be as straight as possible with no hard bends and is to be anchored according to Manufacturer's requirements. The flexible hose can be exchanged with a hose of equal size and equal or greater pressure rating. Anchor requirements, specification sheet and hydrostatic pressure test certification matching the

hose in service, to be onsite for review. These documents shall be posted in the company man's trailer and on the rig floor.

3. 5M or higher system requires an HCR valve, remote kill line and annular to match. The remote kill line is to be installed prior to testing the system and tested to stack pressure.
4. If the operator has proposed a multi-bowl wellhead assembly in the APD. The following requirements must be met:
  - i. Wellhead shall be installed by manufacturer's representatives, submit documentation with subsequent sundry.
  - ii. If the welding is performed by a third party, the manufacturer's representative shall monitor the temperature to verify that it does not exceed the maximum temperature of the seal.
  - iii. Manufacturer representative shall install the test plug for the initial BOP test.
  - iv. Whenever any seal subject to test pressure is broken, all the tests in 43 CFR 3172.6(b)(9) must be followed.
  - v. If the cement does not circulate and one-inch operations would have been possible with a standard wellhead, the well head shall be cut off, cementing operations performed and another wellhead installed.
5. The appropriate BLM office shall be notified a minimum of 4 hours in advance for a representative to witness the tests.
  - i. In a water basin, for all casing strings utilizing slips, these are to be set as soon as the crew and rig are ready and any fallback cement remediation has been done. The casing cut-off and BOP installation can be initiated four hours after installing the slips, which will be approximately six hours after bumping the plug. For those casing strings not using slips, the minimum wait time before cut-off is eight hours after bumping the plug. BOP/BOPE testing can begin after cut-off or once cement reaches 500 psi compressive strength (including lead cement), whichever is greater. However, if the float does not hold, cut-off cannot be initiated until cement reaches 500 psi compressive strength (including lead when specified).
  - ii. In potash areas, for all casing strings utilizing slips, these are to be set as soon as the crew and rig are ready and any fallback cement remediation has been done. For all casing strings, casing cut-off and BOP installation can be initiated at twelve hours after bumping the cement plug. The BOPE test can be initiated after bumping the cement plug with the casing valve open. (Only applies to single stage cement jobs, prior to the cement setting up.)
  - iii. The tests shall be done by an independent service company utilizing a test plug not a cup or J-packer and can be initiated immediately with the casing valve open. The operator also has the option of utilizing an independent tester to test without a plug (i.e. against the casing) pursuant to **43 CFR 3172** with the pressure not to exceed 70% of the burst rating for the casing. Any test against the casing must meet the

WOC time for 8 hours or 500 pounds compressive strength, whichever is greater, prior to initiating the test (see casing segment as lead cement may be critical item).

- iv. The test shall be run on a 5000-psi chart for a 2-3M BOP/BOP, on a 10000 psi chart for a 5M BOP/BOPE and on a 15000 psi chart for a 10M BOP/BOPE. If a linear chart is used, it shall be a one-hour chart. A circular chart shall have a maximum 2-hour clock. If a twelve hour or twenty-four-hour chart is used, tester shall make a notation that it is run with a two hour clock.
- v. The results of the test shall be reported to the appropriate BLM office.
- vi. All tests are required to be recorded on a calibrated test chart. A copy of the BOP/BOPE test chart and a copy of independent service company test will be submitted to the appropriate BLM office.
- vii. The BOP/BOPE test shall include a low-pressure test from 250 to 300 psi. The test will be held for a minimum of 10 minutes if test is done with a test plug and 30 minutes without a test plug. This test shall be performed prior to the test at full stack pressure.
- viii. BOP/BOPE must be tested by an independent service company within 500 feet of the top of the Wolfcamp formation if the time between the setting of the intermediate casing and reaching this depth exceeds 20 days. This test does not exclude the test prior to drilling out the casing shoe as per **43 CFR 3172**.

### **C. DRILLING MUD**

Mud system monitoring equipment, with derrick floor indicators and visual and audio alarms, shall be operating before drilling into the Wolfcamp formation, and shall be used until production casing is run and cemented.

### **D. WASTE MATERIAL AND FLUIDS**

All waste (i.e. drilling fluids, trash, salts, chemicals, sewage, gray water, etc.) created as a result of drilling operations and completion operations shall be safely contained and disposed of properly at a waste disposal facility. No waste material or fluid shall be disposed of on the well location or surrounding area. Porto-johns and trash containers will be on-location during fracturing operations or any other crew-intensive operations.

**SA 02/17/2026**

<b>C-102</b> Submit Electronically Via OCD Permitting	State of New Mexico Energy, Minerals & Natural Resources Department <b>OIL CONSERVATION DIVISION</b>	Revised July 9, 2024
	Submittal Type: <input type="checkbox"/> Initial Submittal <input checked="" type="checkbox"/> Amended Report <input type="checkbox"/> As Drilled	

**WELL LOCATION AND ACREAGE DEDICATION PLAT**

API Number <b>30-025-55930</b>	Pool Code <b>96438</b>	Pool Name <b>HAT MESA; WOLFCAMP</b>
Property Code <b>338848</b>	Property Name <b>SUSAN LANCASTER FED COM</b>	Well Number <b>202H</b>
OGRID No. <b>228937</b>	Operator Name <b>MATADOR PRODUCTION COMPANY</b>	Ground Level Elevation <b>3632'</b>
Surface Owner: <input type="checkbox"/> State <input type="checkbox"/> Fee <input type="checkbox"/> Tribal <input checked="" type="checkbox"/> Federal		Mineral Owner: <input checked="" type="checkbox"/> State <input type="checkbox"/> Fee <input type="checkbox"/> Tribal <input checked="" type="checkbox"/> Federal

**Surface Location**

UL or lot no.	Section	Township	Range	Lot Idn	Feet from the N/S	Feet from the E/W	Latitude	Longitude	County
C	7	21-S	32-E	-	279' N	1683' W	N 32.4996263	W 103.7174445	LEA

**Bottom Hole Location**

UL or lot no.	Section	Township	Range	Lot Idn	Feet from the N/S	Feet from the E/W	Latitude	Longitude	County
K	36	20-S	32-E	-	2527' S	2315' W	N 32.5293191	W 103.7208073	LEA

Dedicated Acres <b>339.45</b>	Infill or Defining Well <b>Infill</b>	Defining Well API <b>NA</b>	Overlapping Spacing Unit (Y/N) <b>N</b>	Consolidated Code <b>O</b>
Order Numbers <b>NA</b>			Well Setbacks are under Common Ownership: <input type="checkbox"/> Yes <input checked="" type="checkbox"/> No	

**Kick Off Point (KOP)**

UL or lot no.	Section	Township	Range	Lot Idn	Feet from the N/S	Feet from the E/W	Latitude	Longitude	County
LOT 18	6	21-S	32-E	-	50' S	1086' W	N 32.5005230	W 103.7193796	LEA

**First Take Point (FTP)**

UL or lot no.	Section	Township	Range	Lot Idn	Feet from the N/S	Feet from the E/W	Latitude	Longitude	County
LOT 18	6	21-S	32-E	-	100' S	1086' W	N 32.5006604	W 103.7193796	LEA

**Last Take Point (LTP)**

UL or lot no.	Section	Township	Range	Lot Idn	Feet from the N/S	Feet from the E/W	Latitude	Longitude	County
K	36	20-S	32-E	-	2527' S	2315' W	N 32.5293191	W 103.7208073	LEA

Unitized Area or Area of Uniform Interest E2E2 Sec. 1, T21S-R31E & W2SW4 Sec 36, T20S-R32E & W2W2 Sec. 6, T21S-R32E & E2SW4 Sec. 36, T20S-R32E	Spacing Unity Type <input checked="" type="checkbox"/> Horizontal <input type="checkbox"/> Vertical	Ground Floor Elevation <b>3660'</b>
---	--	--

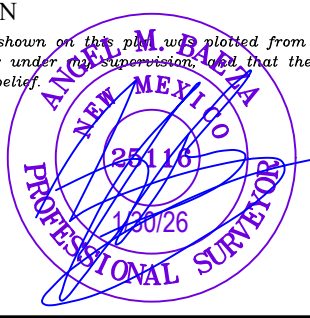
<p><b>OPERATOR CERTIFICATION</b></p> <p><i>I hereby certify that the information contained herein is true and complete to the best of my knowledge and belief, and, if the well is a vertical or directional well, that this organization either owns a working interest or unleased mineral interest in the land including the proposed bottom hole location or has a right to drill this well at this location pursuant to a contract with an owner of a working interest or unleased mineral interest, or to a voluntary pooling agreement or a compulsory pooling order heretofore entered by the division.</i></p> <p><i>If this well is a horizontal well, I further certify that this organization has received The consent of at least one lessee or owner of a working interest or unleased mineral interest in each tract (in the target pool or formation) in which any part of the well's completed interval will be located or obtained a compulsory pooling order from the division.</i></p> <p style="font-size: 1.2em;"><i>Addison Fisher</i>                      2/14/2026</p>	<p><b>SURVEYORS CERTIFICATION</b></p> <p><i>I hereby certify that the well location shown on this plat was plotted from field notes of actual surveys made by me or under my supervision and that the same is true and correct to the best of my belief.</i></p> <div style="text-align: center;">  </div> <p style="text-align: center;">1/30/26</p>
Signature <b>Addison Fisher</b>	Signature and Seal of Professional Surveyor
Date <b>2/14/2026</b>	Date <b>1/30/26</b>
Print Name <b>addison.fisher@matadorresources.com</b>	Certificate Number <b>25116</b>
E-mail Address	Date of Survey <b>01/30/2026</b>

**C-102**  
 Submit Electronically  
 Via OCD Permitting

State of New Mexico  
 Energy, Minerals & Natural Resources Department  
**OIL CONSERVATION DIVISION**

Revised July 9, 2024

Submittal Type:  
 Initial Submittal  
 Amended Report  
 As Drilled

Property Name and Well Number  
**SUSAN LANCASTER FED COM 202H**

**SURFACE LOCATION (SHL)**

NEW MEXICO EAST  
 NAD 1983  
 X=731215 Y=546043  
 LAT.: N 32.4996263  
 LONG.: W 103.7174445

**NAD 1927**  
 X=690034 Y=545982  
 LAT.: N 32.4995050  
 LONG.: W 103.71649504  
 279' FNL 1683' FWL

**KICK OFF POINT (KOP)**

NEW MEXICO EAST  
 NAD 1983  
 X=730616 Y=546366  
 LAT.: N 32.5005230  
 LONG.: W 103.7193796

**NAD 1927**  
 X=689435 Y=546305  
 LAT.: N 32.5004017  
 LONG.: W 103.7188853  
 50' FSL 1086' FWL

**FIRST PERF. POINT (FPP)**

NEW MEXICO EAST  
 NAD 1983  
 X=730616 Y=546416  
 LAT.: N 32.5006604  
 LONG.: W 103.7193796

**NAD 1927**  
 X=689435 Y=546355  
 LAT.: N 32.5005391  
 LONG.: W 103.7188854  
 100' FSL 1086' FWL

**BLM PERF. POINT (BPP1)**

NEW MEXICO EAST  
 NAD 1983  
 X=730583 Y=551597  
 LAT.: N 32.5149030  
 LONG.: W 103.7193883

**NAD 1927**  
 X=689403 Y=551536  
 LAT.: N 32.5147819  
 LONG.: W 103.7188935  
 2718' FNL 1082' FWL

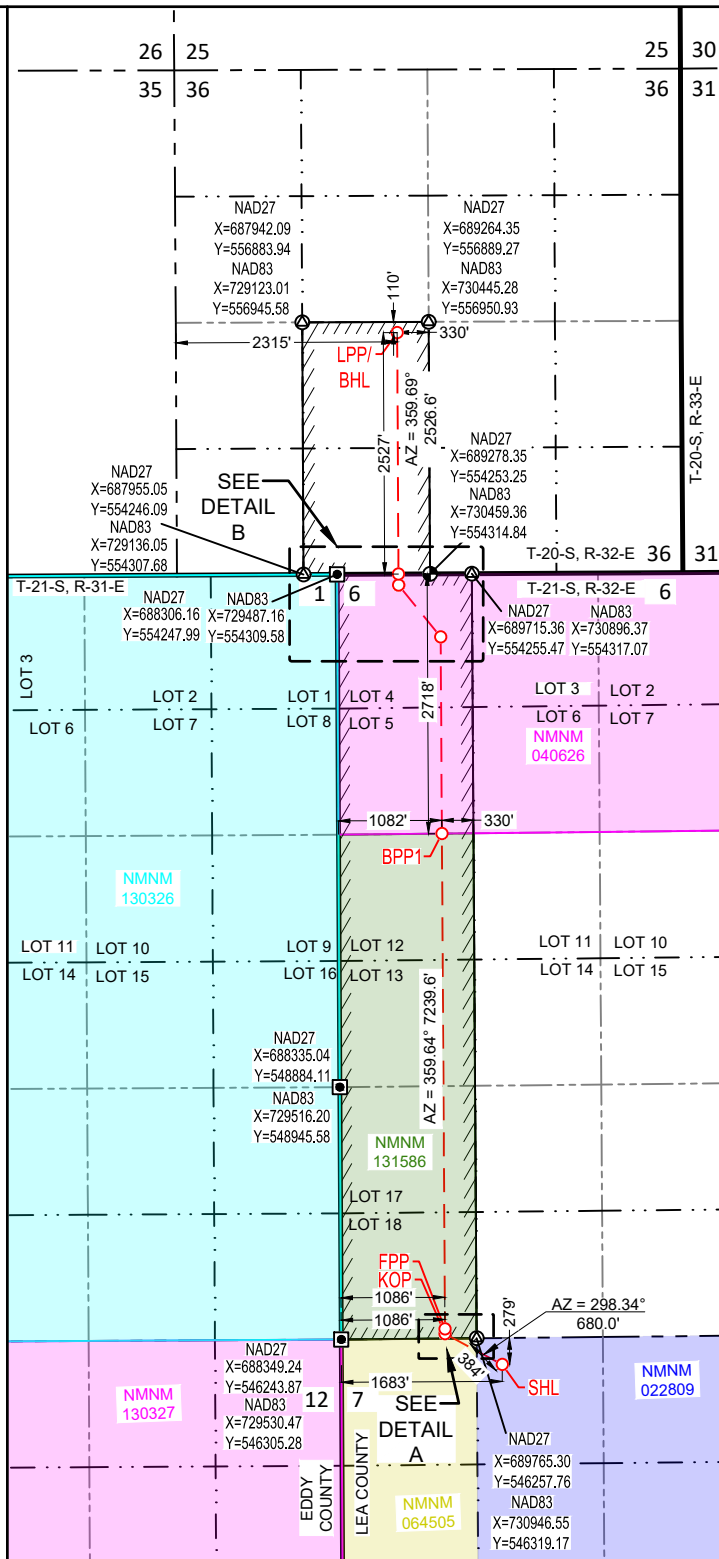

**DEFLECTION POINT (DP1)**

NEW MEXICO EAST  
 NAD 1983  
 X=730571 Y=553655  
 LAT.: N 32.5205597  
 LONG.: W 103.7193917

**NAD 1927**  
 X=689390 Y=553594  
 LAT.: N 32.5204387  
 LONG.: W 103.7188966  
 660' FNL 1080' FWL

**DEFLECTION POINT (DP2)**

NEW MEXICO EAST  
 NAD 1983  
 X=730130 Y=554197  
 LAT.: N 32.5220547  
 LONG.: W 103.7208108

**NAD 1927**  
 X=688949 Y=554135  
 LAT.: N 32.5219337  
 LONG.: W 103.7203156  
 116' FNL 642' FWL

**BLM PERF. POINT (BPP2)**

NEW MEXICO EAST  
 NAD 1983  
 X=730129 Y=554313  
 LAT.: N 32.5223744  
 LONG.: W 103.7208107

**NAD 1927**  
 X=688949 Y=554252  
 LAT.: N 32.5222533  
 LONG.: W 103.7203154  
 0' FSL 993' FWL

**LAST PERF. POINT (LPP)**

NEW MEXICO EAST  
 NAD 1983  
 X=730116 Y=556840  
 LAT.: N 32.5293191  
 LONG.: W 103.7208073

**NAD 1927**  
 X=688935 Y=556778  
 LAT.: N 32.5291982  
 LONG.: W 103.7203117  
 2527' FSL 2315' FWL

**DETAIL VIEW A**

SCALE: 1" = 300'

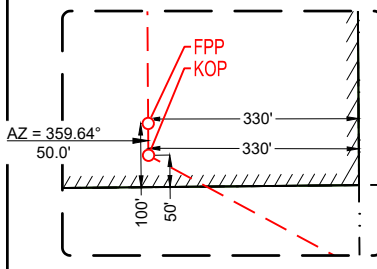

**DETAIL VIEW B**

SCALE: 1" = 1000'

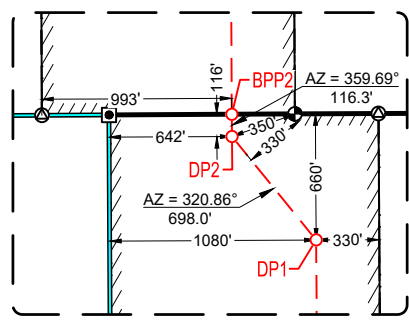

**SURVEYORS CERTIFICATION**

I hereby certify that the well location shown on this plat was plotted from field notes of actual surveys made by me or under my supervision, and that the same is true and correct to the best of my belief.  
 01/30/2026

Date of Survey  
 Signature and Seal of Professional Surveyor:



S:\SUSAN LANCASTER, RESOURCES\SUSAN LANCASTER\_072165.DEP\FINAL\_PRODUCT\TALO\_SUSAN LANCASTER\_FED\_COM\_202H\_REV2.dwg, MIKE WALLER 10/20/20 2:11 PM



SECTION 7, TOWNSHIP 21-S, RANGE 32-E, N.M.P.M. LEA COUNTY, NEW MEXICO

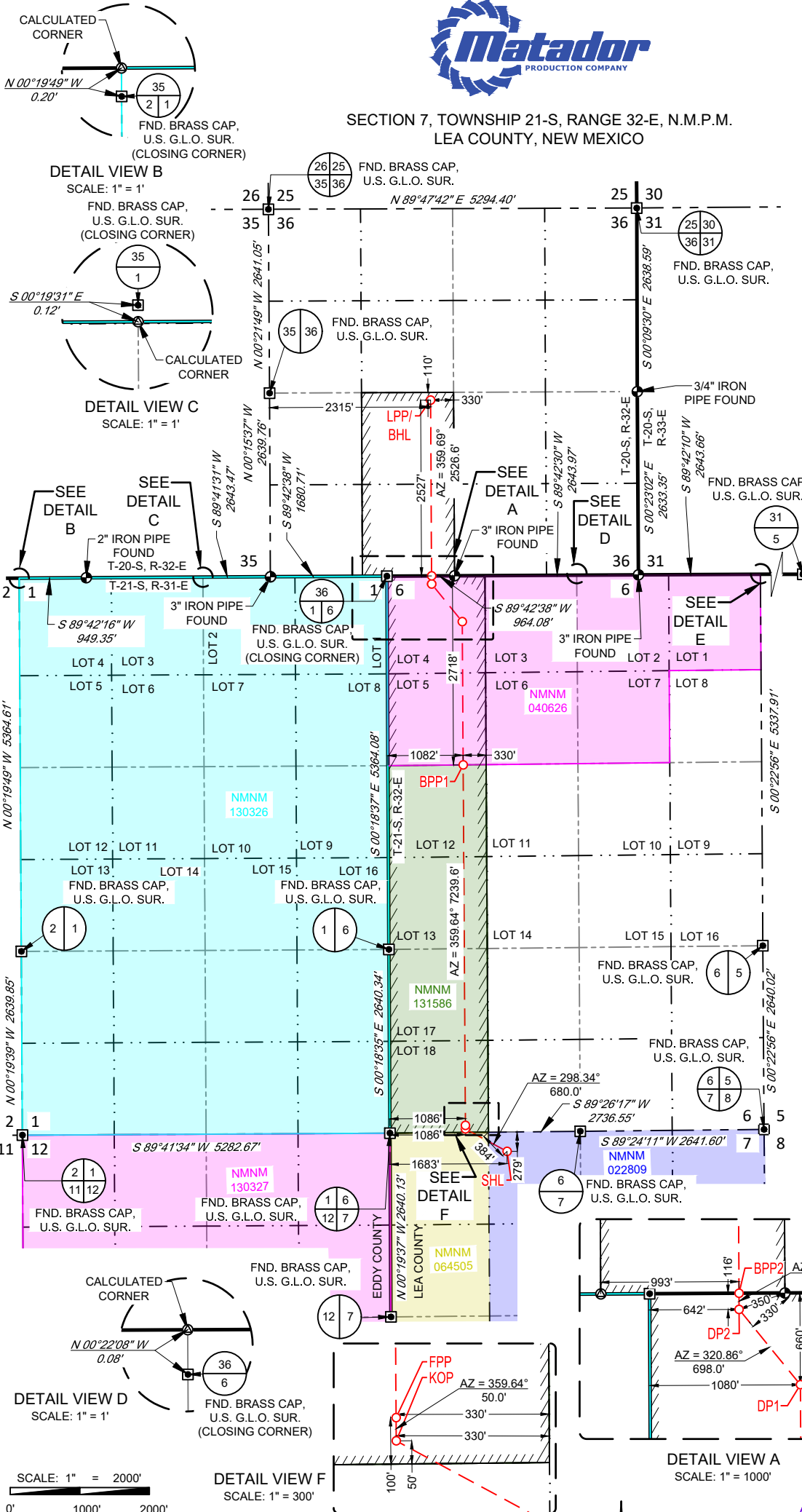

- SURFACE LOCATION (SHL)**  
NEW MEXICO EAST NAD 1983  
X=731215 Y=546043  
LAT.: N 32.4996263  
LONG.: W 103.7174445  
279' FNL 1683' FWL
- KICK OFF POINT (KOP)**  
NEW MEXICO EAST NAD 1983  
X=730616 Y=546366  
LAT.: N 32.5005230  
LONG.: W 103.7193796  
50' FSL 1086' FWL
- FIRST PERF. POINT (FPP)**  
NEW MEXICO EAST NAD 1983  
X=730616 Y=546416  
LAT.: N 32.5006604  
LONG.: W 103.7193796  
100' FSL 1086' FWL
- BLM PERF. POINT (BPP1)**  
NEW MEXICO EAST NAD 1983  
X=730583 Y=551597  
LAT.: N 32.5149030  
LONG.: W 103.7193883  
2718' FNL 1082' FWL
- DEFLECTION POINT (DP1)**  
NEW MEXICO EAST NAD 1983  
X=730571 Y=553655  
LAT.: N 32.5205597  
LONG.: W 103.7193917  
660' FNL 1080' FWL
- DEFLECTION POINT (DP2)**  
NEW MEXICO EAST NAD 1983  
X=730130 Y=554197  
LAT.: N 32.5220547  
LONG.: W 103.7208108  
116' FNL 642' FWL
- BLM PERF. POINT (BPP2)**  
NEW MEXICO EAST NAD 1983  
X=730129 Y=554313  
LAT.: N 32.5223744  
LONG.: W 103.7208107  
0' FSL 993' FWL
- LAST PERF. POINT (LPP)**
- BOTTOM HOLE LOCATION (BHL)**  
NEW MEXICO EAST NAD 1983  
X=730116 Y=556840  
LAT.: N 32.5293191  
LONG.: W 103.7208073  
2527' FSL 2315' FWL

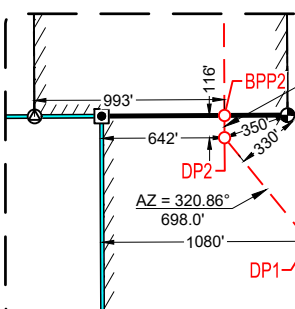
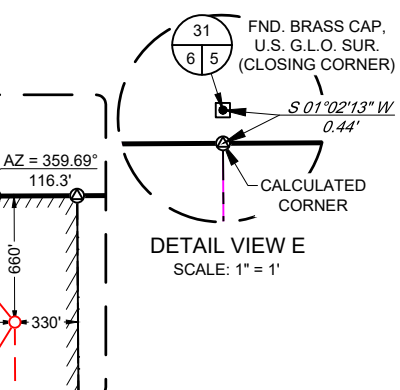

LEASE NAME & WELL NO.: SUSAN LANCASTER FED COM 202H

SECTION 7 TWP 21-S RGE 32-E SURVEY N.M.P.M.  
COUNTY LEA STATE NM  
DESCRIPTION 279' FNL & 1683' FWL

DISTANCE & DIRECTION  
FROM INT. OF NM-243 & US-180E/US-62 E. GO SOUTHWEST ON US-180W/US-62 W ±1.2 MILES, THENCE SOUTH (LEFT) ON CAMPBELL RD. ±3.8 MILES, THENCE EAST (LEFT) ON A PROPOSED RD. ±4505 FEET TO A POINT ±238 FEET NORTHEAST OF THE LOCATION.

ALL BEARINGS, DISTANCES, AND COORDINATE VALUES CONTAINED HEREON ARE GRID BASED UPON THE NEW MEXICO COORDINATE SYSTEM OF 1983, EAST ZONE, U.S. SURVEY FEET  
THIS EASEMENT/SERVITUDE LOCATION SHOWN HEREON HAS BEEN SURVEYED ON THE GROUND UNDER MY SUPERVISION AND PREPARED ACCORDING TO THE EVIDENCE FOUND AT THE TIME OF SURVEY, AND DATA PROVIDED BY MATADOR PRODUCTION COMPANY. THIS CERTIFICATION IS MADE AND LIMITED TO THOSE PERSONS OR ENTITIES SHOWN ON THE FACE OF THIS PLAT AND IS NON-TRANSFERABLE. THIS SURVEY IS CERTIFIED FOR THIS TRANSACTION ONLY.  
AS OF THE DATE OF SURVEY, ALL ABOVE GROUND APPURTENANCES WITHIN 300' OF THE STAKED LOCATION ARE SHOWN HEREON.

Angel M. Baeza, P.S. No. 25116

LOYALTY INNOVATION LEGACY  
481 WINSCOTT ROAD, Ste. 200 • BENBROOK, TEXAS 76126  
TELEPHONE: (817) 744-7512 • FAX (817) 744-7554  
2903 NORTH BIG SPRING • MIDLAND, TEXAS 79705  
TELEPHONE: (432) 682-1653 OR (800) 767-1653 • FAX (432) 682-1743  
WWW.TOPOGRAPHIC.COM



LEGEND

- COUNTY LINE
- SECTION LINE
- PROPOSED ROAD

SECTION 7, TOWNSHIP 21-S, RANGE 32-E, N.M.P.M.  
LEA COUNTY, NEW MEXICO

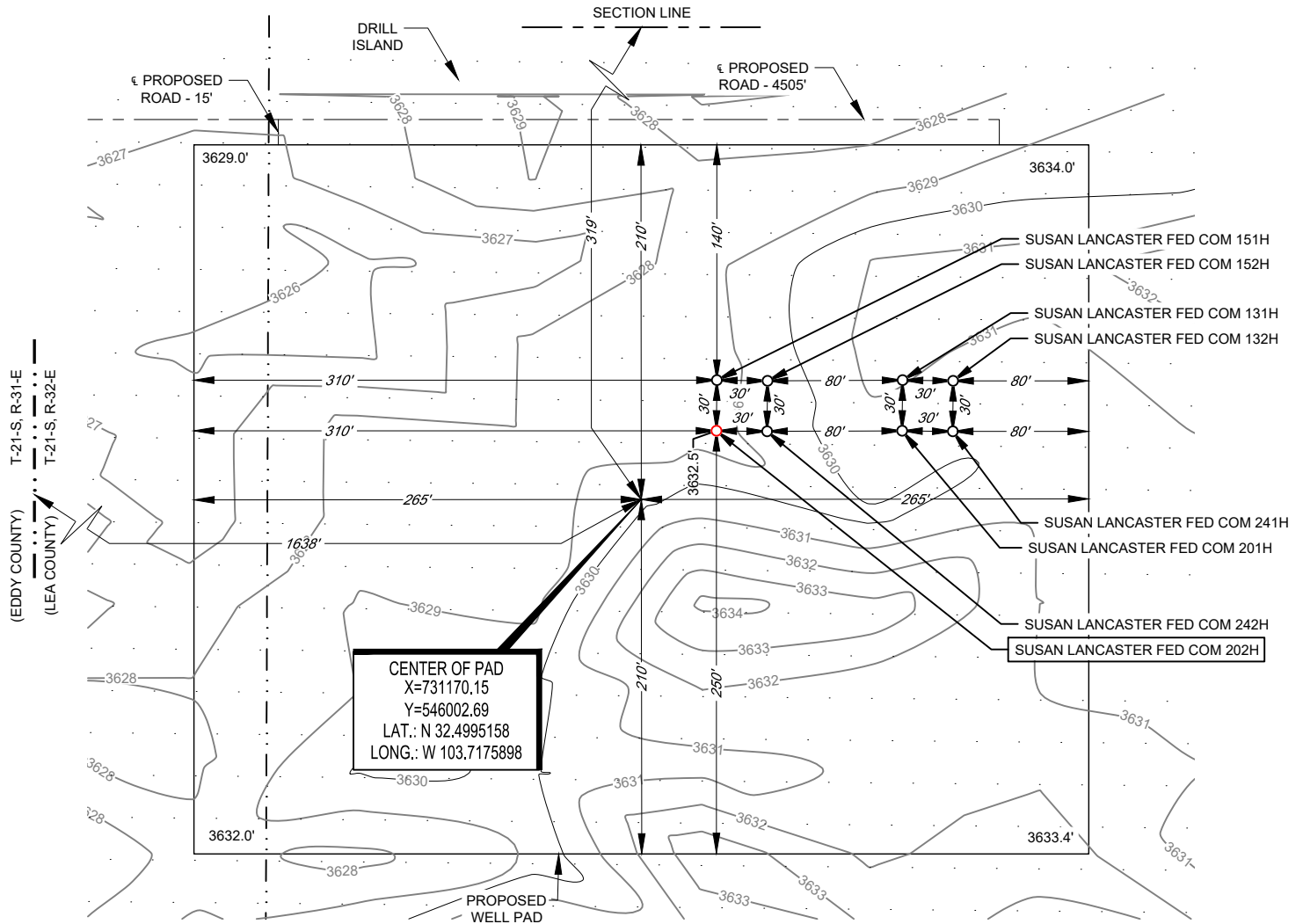

EDDY COUNTY (LEA COUNTY)  
T-21-S, R-31-E  
T-21-S, R-32-E



Angel M. Baeza, P.S. No. 25116

LEASE NAME & WELL NO.: SUSAN LANCASTER FED COM 202H  
 202H LATITUDE N 32.4996263 202H LONGITUDE W 103.7174445

CENTER OF PAD IS 319' FNL & 1638' FWL

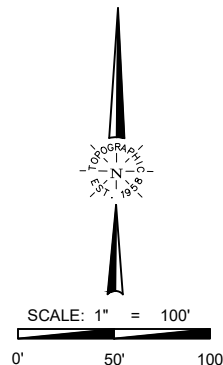

ALL BEARINGS, DISTANCES, AND COORDINATE VALUES CONTAINED HEREON ARE GRID BASED UPON THE NEW MEXICO COORDINATE SYSTEM OF 1983, EAST ZONE, U.S. SURVEY FEET. ELEVATIONS USED ARE NAVD88, OBTAINED THROUGH AN OPUS SOLUTION.

THIS PROPOSED PAD SITE LOCATION SHOWN HEREON HAS BEEN SURVEYED ON THE GROUND UNDER MY SUPERVISION AND PREPARED ACCORDING TO THE EVIDENCE FOUND AT THE TIME OF SURVEY, AND DATA PROVIDED BY MATADOR PRODUCTION COMPANY. ONLY THE DATA SHOWN ABOVE IS BEING CERTIFIED TO. ALL OTHER INFORMATION WAS INTENTIONALLY OMITTED. THIS PLAT IS ONLY INTENDED TO BE USED FOR A PERMIT AND IS NOT A BOUNDARY SURVEY. THIS CERTIFICATION IS MADE AND LIMITED TO THOSE PERSONS OR ENTITIES SHOWN ON THE FACE OF THIS PLAT AND IS NON-TRANSFERABLE. THIS SURVEY IS CERTIFIED FOR THIS TRANSACTION ONLY.



481 WINSOTT ROAD, Ste. 200 • BENBROOK, TEXAS 76126  
 TELEPHONE: (817) 744-7512 • FAX (817) 744-7554  
 2903 NORTH BIG SPRING • MIDLAND, TEXAS 79705  
 TELEPHONE: (432) 682-1653 OR (800) 767-1653 • FAX (432) 682-1743  
 WWW.TOPOGRAPHIC.COM

ORIGINAL DOCUMENT SIZE: 8.5" X 11"



**Susan Lancaster Fed Com 202H**  
**SHL: 279' FNL & 1683' FWL Section 7**  
**BHL: 2527' FSL & 2315' FWL Section 36**  
**Township/Range: 21S 32E**  
**Elevation Above Sea Level: 3632**

### **Sundry Request**

Matador requests the option to amend the well design of the Susan Lancaster Fed Com #202H and make the following changes to the current APD:

- Change well SHL from 279' FNL & 1823' FWL section 7 to 279' FNL & 1683' FWL section 7.
- Modify casing set depths as shown in the casing & cementing table. Cement volumes will be adjusted accordingly.

### **Drilling Operation Plan**

Proposed Drilling Depth: 22392' MD / 11562' TVD

Type of well: Horizontal well, no pilot hole

Permitted Well Type: Oil

Geologic Name of Surface Formation: Quaternary Deposits

KOP Lat/Long (NAD83): 32.500523 N / -103.7193796 W

TD Lat/Long (NAD83): 32.5293191 N / -103.7208073 W

### **1. Estimated Tops**

Formation	MD (ft)	TVD (ft)	Thickness (ft)	Lithology	Resource
Rustler	1,045	1,045	415	Anhydrite	Barren
Salado (Top of Salt)	1,461	1,460	1,456	Salt	Barren
Lamar (Base of Salt)	2,916	2,916	379	Salt	Barren
Capitan	3,295	3,295	1,274	Limestone	Barren
Bell Canyon	4,572	4,569	539	Sandstone	Oil/Natural Gas
Cherry Canyon	5,114	5,108	1,523	Sandstone	Oil/Natural Gas
Brushy Canyon	6,644	6,631	1,731	Sandstone	Oil/Natural Gas
Bone Spring Lime	8,383	8,362	394	Limestone	Oil/Natural Gas
Avalon Shale	8,779	8,756	209	Shale	Oil/Natural Gas
Avalon Carb	8,989	8,965	427	Carbonate	Oil/Natural Gas
1st Bone Spring Sand	9,418	9,392	293	Sandstone	Oil/Natural Gas
2nd Bone Spring Carb	9,712	9,685	297	Carbonate	Oil/Natural Gas
2nd Bone Spring Sand	10,010	9,982	531	Sandstone	Oil/Natural Gas
3rd Bone Spring Carb	10,544	10,513	494	Carbonate	Oil/Natural Gas
<b>KOP</b>	<b>11,019</b>	<b>10,987</b>	-	<b>Carbonate</b>	<b>Oil/Natural Gas</b>
3rd Bone Spring Sand	11,039	11,007	462	Sandstone	Oil/Natural Gas
Wolfcamp A	11,592	11,469	122	Shale	Oil/Natural Gas
<b>TD</b>	<b>22,392</b>	<b>11,562</b>	-	<b>Shale</b>	<b>Oil/Natural Gas</b>
Wolfcamp B	-	11,591	-	Shale	Oil/Natural Gas

### **2. Notable Zones**

Wolfcamp A is the goal. All perforations will be within the setback requirements as prescribed or permitted by the New Mexico Oil Conservation Division. OSE estimated ground water depth at this location is 70'.

### **3. Pressure Control**

#### Equipment

A 12,000' 5000-psi BOP stack consisting of 3 rams with 2 pipe rams, 1 blind ram, and one annular preventer will be utilized below surface casing to TD. See attachments for BOP and choke manifold diagrams.

An accumulator complying with Title 43 CFR 3172 requirements for the pressure rating of the BOP stack will be present. A rotating head will also be installed as needed.

#### Testing Procedure

BOP will be inspected and operated as required in Title 43 CFR 3172. Kelly cock and sub equipped with a full opening valve sized to fit the drill pipe and collars will be available on the rig floor in the open position.

A third party company will test the BOPs.

After setting surface casing, a minimum 5M BOPE system will be installed. Test pressures will be 250 psi low and 5000 psi high with the annular preventer being tested to 250 psi low and 2500 psi high before drilling below surface shoe. In the event that the rig drills multiple wells on the pad and any seal subject to test pressures are broken, a full BOP test will be performed when the rig returns and the 5M BOPE system is re-installed.

#### Variance Request

Matador requests a variance to have the option of running a multi-bowl wellhead assembly for setting the Intermediate 1, Intermediate 2, and Production Strings. The BOPs will not be tested again unless any flanges are separated.

Matador requests a variance to drill this well using a co-flex line between the BOP and choke manifold. Certification for proposed co-flex hose is attached. The hose is not required by the manufacturer to be anchored. If the specific hose is not available, then one of equal or higher rating will be used.

Matador requests a variance to have the option of batch drilling this well with other wells on the same pad. In the event that this well is batch drilled, the wellbore will be secured with a blind flange of like pressure. When the rig returns to this well and BOPs are installed, the operator will perform a full BOP test.

Matador request the option to offline cement surface casing. The "Offline Cementing - Surface Casing" Procedure is attached for review. No changes in cement program are necessary.

Matador request the option to offline cement intermediate casing. The "Offline Cementing - Intermediate Casing" Procedure is attached for review. No changes in cement program are necessary.

Matador request the option to break test the BOP during batch drilling operations. The "Modified BOP Testing Procedure for Batch Drilling" Procedure is attached for review.

Matador request the option to utilize a spudder rig for setting surface and intermediate 1 casing strings.

**4. Casing & Cement**

All casing will be API and new. See attached casing assumption worksheet.

String	Hole Size (in)	Set MD (ft)	Set TVD (ft)	Casing Size (in)	Wt. (lb/ft)	Grade	Joint	Collapse	Burst	Tension
Surface	17.5	0 - 1115	0 - 1115	13.375	54.5	J-55	BUTT	1.125	1.125	1.8
Intermediate 1	12.25	0 - 3016	0 - 3016	10.75	45.5	HCL-80	BUTT-SC	1.125	1.125	1.8
Intermediate 2	9.875	0 - 5106	0 - 5100	8.625	32	P-110	Hunting TLW	1.125	1.125	1.8
Production	7.875	0 - 22392	0 - 11562	5.5	20	P-110	Hunting TLW	1.125	1.125	1.8

- All casing strings will be tested in accordance with Title 43 CFR 3172.7(b)(8)

- All applicable R-111-Q regulations will be adhered to

- Rustler top will be validated via drilling parameters (i.e. reduction in ROP) and surface casing setting depth revised accordingly if needed

- All non-API joint connections will be of like or greater quality, and as run specification sheets will be on location for

- Request option to drill 6.75" production hole from KOP to TD, cement volumes will be adjusted accordingly.

**Variance Request**

Matador request a variance to wave the centralizer requirement for the 8-5/8" casing and the 5-1/2" SF/Flush casing in the 7-7/8" hole.

If a DV tool is used, depth(s) will be adjusted based on hole conditions and cement volumes will be adjusted proportionally. DV tool will be set a minimum of 50 feet below previous casing and a minimum of 200 feet above the current shoe. Lab reports with the 500 psi compressive strength time for the cement will be onsite for review. Option to cancel 2nd stage cement if cement is circulated on 1st stage.

Matador request a variance to utilize a surface setting rig. If this is used, Matador request the option to drill 20" surface hole, cement volumes will be adjusted accordingly.

**Primary Cement Design - DV/Packer 2-Stage Cement**

String	Type	Sacks	Yield	Cu. Ft.	Weight	Percent Excess	Top of Cement (ft)	Class	Blend
Surface	Lead	550	1.72	941	13.5	50%	0	C	5% NaCl + LCM
	Tail	250	1.38	347	14.8	50%	815	C	5% NaCl + LCM
Intermediate 1 w/ DV @ 1165'	Stg 2 Tail	150	1.78	275	13.5	10%	0	C	10% NaCl + 1% MgO + LCM
	Stg 1 Lead	380	1.84	703	12.5	50%	0	C	10% NaCl + 1% MgO + LCM
	Stg 1 Tail	140	1.33	192	14.8	50%	2413	C	10% NaCl + 1% MgO + LCM
Intermediate 2 w/ DV @ 3066'	Stg 2 Tail	230	1.78	412	13.5	10%	0	C	5% NaCl + LCM
	Stg 1 Lead	260	3.66	965	10.3	35%	0	A/C	Bentonite + 1% CaCL2 + 8% NaCl + LCM
	Stg 1 Tail	120	1.38	170	13.2	35%	4106	A/C	5% NaCl + LCM
Production	Lead	190	3.66	694	12.5	0%	6106	A/C	Bentonite + 1% CaCL2 + 8% NaCl + LCM
	Tail	1590	1.35	2144	13.2	0%	10019	A/C	Fluid Loss + Dispersant + Retarder

**Post-Completion Cement Design - Bradenhead Squeeze**

String	Type	Sacks	Yield	Cu. Ft.	Weight	Percent Excess	Top of Cement (ft)	Class	Blend
Production	Stg 2 Tail	260	3.66	959	12.5	25%	4606	A/C	Fluid Loss + Dispersant + Retarder
	Stg 1 Lead	190	3.66	694	12.5	0%	6106	A/C	Bentonite + 1% CaCL <sub>2</sub> + 8% NaCl + LCM
	Stg 1 Tail	1590	1.35	2144	13.2	0%	10019	A/C	Fluid Loss + Dispersant + Retarder

Matador plans to cement the production string per R-111-Q.(C).(5).(c).(iii), leaving the annulus open between the 2nd intermediate and production casing strings for a minimum of 500' until hydraulic fracturing operations have been concluded, at which point a bradenhead cementing operation will take place, ensuring at least 500' tie-back into 2nd intermediate casing, but not higher than USGS Marker Bed No. 126. TOC for the primary production job will be determined by CBL prior to hydraulic fracturing. As per R-111-Q.(C).(6).(c).(i), the production cement will have a zero free fluid and a HTHP fluid loss of 150 ml/30min.

As per R-111-Q.(C).(5).(c), the annulus between int. 2 and production casing will be monitored and designed to relieve pressure from annulus below the failure threshold.

**5. Mud Program**

An electronic Pason mud monitoring system complying with Title 43 CFR 3172 will be used. All necessary mud products (barite, bentonite, LCM) for weight addition and fluid loss control will be on location at all times. Mud program is subject to change due to hole conditions.

Hole Section	Hole Size (in)	Mud Type	Interval MD (ft)	Density (lb/gal)	Viscosity	Fluid Loss
Surface	17.5	Spud Mud	0 - 1115	8.4 - 8.8	28-30	NC
Intermediate 1	12.25	Brine	1115 - 3016	9.8 - 10.2	28-30	NC
Intermediate 2	9.875	Fresh Water	3016 - 5106	8.4 - 8.8	28-30	NC
Production	7.875	OBM/Cut Brine	5106 - 22392	10.6 - 11.4	50-65	<20

**6. Cores, Test, & Logs**

No core or drill stem test is planned.

No electric logs are planned at this time. GR will be collected through the MWD tools from Intermediate casing to TD. CBL with CCL will be run as far as gravity will let it fall to top of curve. We will be running a Neutron log on one of the wells on each pad.

**7. Down Hole Conditions**

No abnormal pressure or temperature is expected. Bottom hole pressure is 6854 psi. Maximum anticipated surface pressure is 4310 psi. Expected bottom hole temperature is 198 F.

In accordance with Title 43 CFR 3176, Matador does not anticipate that there will be enough H<sub>2</sub>S from the surface to the Bone Spring formations to meet the BLM's minimum requirements for the submission of an "H<sub>2</sub>S Drilling Operation Plan" or "Public Protection Plan" for the drilling and completion of this well. Since we have an H<sub>2</sub>S safety package on all wells, attached is an "H<sub>2</sub>S Drilling Operations Plan". Adequate flare lines will be installed off the mud/gas separator where gas may be flared safely. All personnel will be familiar with all aspects of safe operation of equipment being used.

### Casing Table Specification Sheet

**Susan Lancaster Fed Com 202H**  
**SHL: 279' FNL & 1683' FWL Section 7**  
**BHL: 2527' FSL & 2315' FWL Section 36**  
**Township/Range: 21S 32E**  
**Elevation Above Sea Level: 3632**

String	Hole Size (in)	Set MD (ft)	Set TVD (ft)	Casing Size (in)	Wt. (lb/ft)	Grade	Joint	Collapse	Burst	Tension
Surface	17.5	0 - 1115	0 - 1115	13.375	54.5	J-55	BUTT	1.125	1.125	1.8
Intermediate 1	12.25	0 - 3016	0 - 3016	10.75	45.5	HCL-80	BUTT-SC	1.125	1.125	1.8
Intermediate 2	9.875	0 - 5106	0 - 5100	8.625	32	P-110	Hunting TLW	1.125	1.125	1.8
Production	7.875	0 - 22392	0 - 11562	5.5	20	P-110	Hunting TLW	1.125	1.125	1.8

# **Matador Production Company**

**Ranger/Arrowhead**

**Susan Lancaster**

**Susan Lancaster Fed Com #202H**

**Wellbore #1**

**Plan: BLM Plan #1**

## **Standard Planning Report**

**04 February, 2026**

Planning Report

<b>Database:</b>	EDM 5000.14 Single User Db	<b>Local Co-ordinate Reference:</b>	Well Susan Lancaster Fed Com #202H
<b>Company:</b>	Matador Production Company	<b>TVD Reference:</b>	KB @ 3660.5usft
<b>Project:</b>	Ranger/Arrowhead	<b>MD Reference:</b>	KB @ 3660.5usft
<b>Site:</b>	Susan Lancaster	<b>North Reference:</b>	Grid
<b>Well:</b>	Susan Lancaster Fed Com #202H	<b>Survey Calculation Method:</b>	Minimum Curvature
<b>Wellbore:</b>	Wellbore #1		
<b>Design:</b>	BLM Plan #1		

<b>Project</b>	Ranger/Arrowhead		
<b>Map System:</b>	US State Plane 1927 (Exact solution)	<b>System Datum:</b>	Mean Sea Level
<b>Geo Datum:</b>	NAD 1927 (NADCON CONUS)		
<b>Map Zone:</b>	New Mexico East 3001		

<b>Site</b>	Susan Lancaster				
<b>Site Position:</b>		<b>Northing:</b>	546,006.58 usft	<b>Latitude:</b>	32° 29' 58.492 N
<b>From:</b>	Lat/Long	<b>Easting:</b>	689,503.73 usft	<b>Longitude:</b>	103° 43' 7.210 W
<b>Position Uncertainty:</b>	0.0 usft	<b>Slot Radius:</b>	13-3/16 "	<b>Grid Convergence:</b>	0.33 °

<b>Well</b>	Susan Lancaster Fed Com #202H					
<b>Well Position</b>	<b>+N/-S</b>	-24.6 usft	<b>Northing:</b>	545,982.00 usft	<b>Latitude:</b>	32° 29' 58.219 N
	<b>+E/-W</b>	530.3 usft	<b>Easting:</b>	690,034.00 usft	<b>Longitude:</b>	103° 43' 1.020 W
<b>Position Uncertainty</b>		0.0 usft	<b>Wellhead Elevation:</b>		<b>Ground Level:</b>	3,632.0 usft

<b>Wellbore</b>	Wellbore #1				
<b>Magnetics</b>	<b>Model Name</b>	<b>Sample Date</b>	<b>Declination (°)</b>	<b>Dip Angle (°)</b>	<b>Field Strength (nT)</b>
	IGRF2015	12/31/2024	6.22	60.19	47,307.70359111

<b>Design</b>	BLM Plan #1			
<b>Audit Notes:</b>				
<b>Version:</b>	<b>Phase:</b>	PLAN	<b>Tie On Depth:</b>	0.0
<b>Vertical Section:</b>	<b>Depth From (TVD) (usft)</b>	<b>+N/-S (usft)</b>	<b>+E/-W (usft)</b>	<b>Direction (°)</b>
	0.0	0.0	0.0	359.64

<b>Plan Survey Tool Program</b>	<b>Date</b>	2/4/2026		
<b>Depth From (usft)</b>	<b>Depth To (usft)</b>	<b>Survey (Wellbore)</b>	<b>Tool Name</b>	<b>Remarks</b>
1	0.0	22,392.1	BLM Plan #1 (Wellbore #1)	MWD OWSG MWD - Standard

Planning Report

<b>Database:</b>	EDM 5000.14 Single User Db	<b>Local Co-ordinate Reference:</b>	Well Susan Lancaster Fed Com #202H
<b>Company:</b>	Matador Production Company	<b>TVD Reference:</b>	KB @ 3660.5usft
<b>Project:</b>	Ranger/Arrowhead	<b>MD Reference:</b>	KB @ 3660.5usft
<b>Site:</b>	Susan Lancaster	<b>North Reference:</b>	Grid
<b>Well:</b>	Susan Lancaster Fed Com #202H	<b>Survey Calculation Method:</b>	Minimum Curvature
<b>Wellbore:</b>	Wellbore #1		
<b>Design:</b>	BLM Plan #1		

Plan Sections										
Measured Depth (usft)	Inclination (°)	Azimuth (°)	Vertical Depth (usft)	+N/-S (usft)	+E/-W (usft)	Dogleg Rate (°/100usft)	Build Rate (°/100usft)	Turn Rate (°/100usft)	TFO (°)	Target
0.0	0.00	0.00	0.0	0.0	0.0	0.00	0.00	0.00	0.00	
993.6	0.00	0.00	993.6	0.0	0.0	0.00	0.00	0.00	0.00	
1,193.6	4.00	190.00	1,193.4	-6.9	-1.2	2.00	2.00	0.00	190.00	
1,460.3	0.00	0.00	1,459.9	-16.0	-2.8	1.50	-1.50	0.00	180.00	
3,300.4	0.00	0.00	3,300.0	-16.0	-2.8	0.00	0.00	0.00	0.00	
3,600.4	6.00	180.00	3,599.5	-31.7	-2.8	2.00	2.00	0.00	180.00	
3,900.4	6.00	180.00	3,897.8	-63.1	-2.8	0.00	0.00	0.00	0.00	
4,300.4	0.00	0.00	4,297.1	-84.0	-2.8	1.50	-1.50	0.00	180.00	
4,400.4	0.00	0.00	4,397.1	-84.0	-2.8	0.00	0.00	0.00	0.00	
4,676.3	5.52	259.92	4,672.6	-86.3	-15.9	2.00	2.00	0.00	259.92	
10,651.1	5.52	259.92	10,619.7	-186.9	-581.6	0.00	0.00	0.00	0.00	
11,019.0	0.00	0.00	10,987.0	-190.0	-599.0	1.50	-1.50	0.00	180.00	KOP - Susan Lancast
11,919.0	90.00	359.64	11,560.0	382.9	-602.6	10.00	10.00	0.00	359.64	
17,419.0	90.00	359.64	11,560.0	5,882.8	-637.2	0.00	0.00	0.00	0.00	
18,542.0	90.00	337.18	11,560.0	6,975.9	-861.3	2.00	0.00	-2.00	-90.00	
19,669.3	89.96	359.73	11,560.3	8,073.3	-1,085.5	2.00	0.00	2.00	90.09	
22,392.2	89.96	359.73	11,562.0	10,796.2	-1,098.5	0.00	0.00	0.00	0.00	BHL - Susan Lancast

Planning Report

<b>Database:</b>	EDM 5000.14 Single User Db	<b>Local Co-ordinate Reference:</b>	Well Susan Lancaster Fed Com #202H
<b>Company:</b>	Matador Production Company	<b>TVD Reference:</b>	KB @ 3660.5usft
<b>Project:</b>	Ranger/Arrowhead	<b>MD Reference:</b>	KB @ 3660.5usft
<b>Site:</b>	Susan Lancaster	<b>North Reference:</b>	Grid
<b>Well:</b>	Susan Lancaster Fed Com #202H	<b>Survey Calculation Method:</b>	Minimum Curvature
<b>Wellbore:</b>	Wellbore #1		
<b>Design:</b>	BLM Plan #1		

Planned Survey									
Measured Depth (usft)	Inclination (°)	Azimuth (°)	Vertical Depth (usft)	+N/-S (usft)	+E/-W (usft)	Vertical Section (usft)	Dogleg Rate (°/100usft)	Build Rate (°/100usft)	Turn Rate (°/100usft)
0.0	0.00	0.00	0.0	0.0	0.0	0.0	0.00	0.00	0.00
100.0	0.00	0.00	100.0	0.0	0.0	0.0	0.00	0.00	0.00
200.0	0.00	0.00	200.0	0.0	0.0	0.0	0.00	0.00	0.00
300.0	0.00	0.00	300.0	0.0	0.0	0.0	0.00	0.00	0.00
400.0	0.00	0.00	400.0	0.0	0.0	0.0	0.00	0.00	0.00
500.0	0.00	0.00	500.0	0.0	0.0	0.0	0.00	0.00	0.00
600.0	0.00	0.00	600.0	0.0	0.0	0.0	0.00	0.00	0.00
700.0	0.00	0.00	700.0	0.0	0.0	0.0	0.00	0.00	0.00
800.0	0.00	0.00	800.0	0.0	0.0	0.0	0.00	0.00	0.00
900.0	0.00	0.00	900.0	0.0	0.0	0.0	0.00	0.00	0.00
993.6	0.00	0.00	993.6	0.0	0.0	0.0	0.00	0.00	0.00
<b>Start Build 2.00</b>									
1,000.0	0.13	190.00	1,000.0	0.0	0.0	0.0	2.00	2.00	0.00
1,045.0	1.03	190.00	1,045.0	-0.5	-0.1	-0.5	2.00	2.00	0.00
<b>Rustler</b>									
1,100.0	2.13	190.00	1,100.0	-1.9	-0.3	-1.9	2.00	2.00	0.00
1,193.6	4.00	190.00	1,193.4	-6.9	-1.2	-6.9	2.00	2.00	0.00
<b>Start Drop -1.50</b>									
1,200.0	3.90	190.00	1,199.8	-7.3	-1.3	-7.3	1.50	-1.50	0.00
1,300.0	2.40	190.00	1,299.7	-12.7	-2.2	-12.7	1.50	-1.50	0.00
1,400.0	0.90	190.00	1,399.6	-15.6	-2.7	-15.5	1.50	-1.50	0.00
1,460.3	0.00	0.00	1,459.9	-16.0	-2.8	-16.0	1.50	-1.50	0.00
<b>Start 1840.1 hold at 1460.3 MD</b>									
1,460.4	0.00	0.00	1,460.0	-16.0	-2.8	-16.0	0.00	0.00	0.00
<b>Salado</b>									
1,500.0	0.00	0.00	1,499.6	-16.0	-2.8	-16.0	0.00	0.00	0.00
1,600.0	0.00	0.00	1,599.6	-16.0	-2.8	-16.0	0.00	0.00	0.00
1,700.0	0.00	0.00	1,699.6	-16.0	-2.8	-16.0	0.00	0.00	0.00
1,800.0	0.00	0.00	1,799.6	-16.0	-2.8	-16.0	0.00	0.00	0.00
1,900.0	0.00	0.00	1,899.6	-16.0	-2.8	-16.0	0.00	0.00	0.00
2,000.0	0.00	0.00	1,999.6	-16.0	-2.8	-16.0	0.00	0.00	0.00
2,100.0	0.00	0.00	2,099.6	-16.0	-2.8	-16.0	0.00	0.00	0.00
2,200.0	0.00	0.00	2,199.6	-16.0	-2.8	-16.0	0.00	0.00	0.00
2,300.0	0.00	0.00	2,299.6	-16.0	-2.8	-16.0	0.00	0.00	0.00
2,400.0	0.00	0.00	2,399.6	-16.0	-2.8	-16.0	0.00	0.00	0.00
2,500.0	0.00	0.00	2,499.6	-16.0	-2.8	-16.0	0.00	0.00	0.00
2,600.0	0.00	0.00	2,599.6	-16.0	-2.8	-16.0	0.00	0.00	0.00
2,700.0	0.00	0.00	2,699.6	-16.0	-2.8	-16.0	0.00	0.00	0.00
2,800.0	0.00	0.00	2,799.6	-16.0	-2.8	-16.0	0.00	0.00	0.00
2,900.0	0.00	0.00	2,899.6	-16.0	-2.8	-16.0	0.00	0.00	0.00
2,916.4	0.00	0.00	2,916.0	-16.0	-2.8	-16.0	0.00	0.00	0.00
<b>G30:CS14-CSB (Lamar/Tansil)</b>									
3,000.0	0.00	0.00	2,999.6	-16.0	-2.8	-16.0	0.00	0.00	0.00
3,100.0	0.00	0.00	3,099.6	-16.0	-2.8	-16.0	0.00	0.00	0.00
3,200.0	0.00	0.00	3,199.6	-16.0	-2.8	-16.0	0.00	0.00	0.00
3,295.4	0.00	0.00	3,295.0	-16.0	-2.8	-16.0	0.00	0.00	0.00
<b>Capitan</b>									
3,300.0	0.00	0.00	3,299.6	-16.0	-2.8	-16.0	0.00	0.00	0.00
3,300.4	0.00	0.00	3,300.0	-16.0	-2.8	-16.0	0.00	0.00	0.00
<b>Start Build 2.00</b>									
3,400.0	1.99	180.00	3,399.6	-17.8	-2.8	-17.7	2.00	2.00	0.00
3,500.0	3.99	180.00	3,499.5	-23.0	-2.8	-23.0	2.00	2.00	0.00
3,600.0	5.99	180.00	3,599.1	-31.7	-2.8	-31.7	2.00	2.00	0.00

Planning Report

<b>Database:</b>	EDM 5000.14 Single User Db	<b>Local Co-ordinate Reference:</b>	Well Susan Lancaster Fed Com #202H
<b>Company:</b>	Matador Production Company	<b>TVD Reference:</b>	KB @ 3660.5usft
<b>Project:</b>	Ranger/Arrowhead	<b>MD Reference:</b>	KB @ 3660.5usft
<b>Site:</b>	Susan Lancaster	<b>North Reference:</b>	Grid
<b>Well:</b>	Susan Lancaster Fed Com #202H	<b>Survey Calculation Method:</b>	Minimum Curvature
<b>Wellbore:</b>	Wellbore #1		
<b>Design:</b>	BLM Plan #1		

Planned Survey										
Measured Depth (usft)	Inclination (°)	Azimuth (°)	Vertical Depth (usft)	+N/-S (usft)	+E/-W (usft)	Vertical Section (usft)	Dogleg Rate (°/100usft)	Build Rate (°/100usft)	Turn Rate (°/100usft)	
3,600.4	6.00	180.00	3,599.5	-31.7	-2.8	-31.7	2.00	2.00	0.00	
<b>Start 300.0 hold at 3600.4 MD</b>										
3,700.0	6.00	180.00	3,698.5	-42.1	-2.8	-42.1	0.00	0.00	0.00	
3,800.0	6.00	180.00	3,798.0	-52.6	-2.8	-52.6	0.00	0.00	0.00	
3,900.0	6.00	180.00	3,897.4	-63.0	-2.8	-63.0	0.00	0.00	0.00	
3,900.4	6.00	180.00	3,897.8	-63.1	-2.8	-63.1	0.00	0.00	0.00	
<b>Start Drop -1.50</b>										
4,000.0	4.51	180.00	3,997.0	-72.2	-2.8	-72.2	1.50	-1.50	0.00	
4,100.0	3.01	180.00	4,096.8	-78.8	-2.8	-78.7	1.50	-1.50	0.00	
4,200.0	1.51	180.00	4,196.7	-82.7	-2.8	-82.7	1.50	-1.50	0.00	
4,300.0	0.01	180.00	4,296.7	-84.0	-2.8	-84.0	1.50	-1.50	0.00	
4,300.4	0.00	0.00	4,297.1	-84.0	-2.8	-84.0	1.50	-1.50	0.00	
<b>Start 100.0 hold at 4300.4 MD</b>										
4,400.0	0.00	0.00	4,396.7	-84.0	-2.8	-84.0	0.00	0.00	0.00	
4,400.4	0.00	0.00	4,397.1	-84.0	-2.8	-84.0	0.00	0.00	0.00	
<b>Start Build 2.00</b>										
4,500.0	1.99	259.92	4,496.7	-84.3	-4.5	-84.3	2.00	2.00	0.00	
4,572.4	3.44	259.92	4,569.0	-84.9	-7.9	-84.9	2.00	2.00	0.00	
<b>G25: Bell Cyn</b>										
4,600.0	3.99	259.92	4,596.5	-85.2	-9.7	-85.2	2.00	2.00	0.00	
4,676.3	5.52	259.92	4,672.6	-86.3	-15.9	-86.2	2.00	2.00	0.00	
<b>Start 5974.8 hold at 4676.3 MD</b>										
4,700.0	5.52	259.92	4,696.2	-86.7	-18.1	-86.6	0.00	0.00	0.00	
4,800.0	5.52	259.92	4,795.7	-88.4	-27.6	-88.2	0.00	0.00	0.00	
4,900.0	5.52	259.92	4,895.2	-90.1	-37.1	-89.9	0.00	0.00	0.00	
5,000.0	5.52	259.92	4,994.8	-91.8	-46.5	-91.5	0.00	0.00	0.00	
5,100.0	5.52	259.92	5,094.3	-93.5	-56.0	-93.1	0.00	0.00	0.00	
5,113.8	5.52	259.92	5,108.0	-93.7	-57.3	-93.3	0.00	0.00	0.00	
<b>G13: Cherry Cyn.</b>										
5,200.0	5.52	259.92	5,193.8	-95.2	-65.5	-94.7	0.00	0.00	0.00	
5,300.0	5.52	259.92	5,293.4	-96.8	-74.9	-96.4	0.00	0.00	0.00	
5,400.0	5.52	259.92	5,392.9	-98.5	-84.4	-98.0	0.00	0.00	0.00	
5,500.0	5.52	259.92	5,492.5	-100.2	-93.9	-99.6	0.00	0.00	0.00	
5,600.0	5.52	259.92	5,592.0	-101.9	-103.4	-101.2	0.00	0.00	0.00	
5,700.0	5.52	259.92	5,691.5	-103.6	-112.8	-102.9	0.00	0.00	0.00	
5,800.0	5.52	259.92	5,791.1	-105.3	-122.3	-104.5	0.00	0.00	0.00	
5,900.0	5.52	259.92	5,890.6	-106.9	-131.8	-106.1	0.00	0.00	0.00	
6,000.0	5.52	259.92	5,990.1	-108.6	-141.2	-107.7	0.00	0.00	0.00	
6,100.0	5.52	259.92	6,089.7	-110.3	-150.7	-109.4	0.00	0.00	0.00	
6,200.0	5.52	259.92	6,189.2	-112.0	-160.2	-111.0	0.00	0.00	0.00	
6,300.0	5.52	259.92	6,288.7	-113.7	-169.6	-112.6	0.00	0.00	0.00	
6,400.0	5.52	259.92	6,388.3	-115.3	-179.1	-114.2	0.00	0.00	0.00	
6,500.0	5.52	259.92	6,487.8	-117.0	-188.6	-115.8	0.00	0.00	0.00	
6,600.0	5.52	259.92	6,587.4	-118.7	-198.0	-117.5	0.00	0.00	0.00	
6,643.8	5.52	259.92	6,631.0	-119.5	-202.2	-118.2	0.00	0.00	0.00	
<b>G7: Brushy Cyn.</b>										
6,700.0	5.52	259.92	6,686.9	-120.4	-207.5	-119.1	0.00	0.00	0.00	
6,800.0	5.52	259.92	6,786.4	-122.1	-217.0	-120.7	0.00	0.00	0.00	
6,900.0	5.52	259.92	6,886.0	-123.8	-226.4	-122.3	0.00	0.00	0.00	
7,000.0	5.52	259.92	6,985.5	-125.4	-235.9	-124.0	0.00	0.00	0.00	
7,100.0	5.52	259.92	7,085.0	-127.1	-245.4	-125.6	0.00	0.00	0.00	
7,200.0	5.52	259.92	7,184.6	-128.8	-254.8	-127.2	0.00	0.00	0.00	
7,300.0	5.52	259.92	7,284.1	-130.5	-264.3	-128.8	0.00	0.00	0.00	

Planning Report

<b>Database:</b>	EDM 5000.14 Single User Db	<b>Local Co-ordinate Reference:</b>	Well Susan Lancaster Fed Com #202H
<b>Company:</b>	Matador Production Company	<b>TVD Reference:</b>	KB @ 3660.5usft
<b>Project:</b>	Ranger/Arrowhead	<b>MD Reference:</b>	KB @ 3660.5usft
<b>Site:</b>	Susan Lancaster	<b>North Reference:</b>	Grid
<b>Well:</b>	Susan Lancaster Fed Com #202H	<b>Survey Calculation Method:</b>	Minimum Curvature
<b>Wellbore:</b>	Wellbore #1		
<b>Design:</b>	BLM Plan #1		

Planned Survey										
Measured Depth (usft)	Inclination (°)	Azimuth (°)	Vertical Depth (usft)	+N/-S (usft)	+E/-W (usft)	Vertical Section (usft)	Dogleg Rate (°/100usft)	Build Rate (°/100usft)	Turn Rate (°/100usft)	
7,400.0	5.52	259.92	7,383.7	-132.2	-273.8	-130.5	0.00	0.00	0.00	
7,500.0	5.52	259.92	7,483.2	-133.9	-283.2	-132.1	0.00	0.00	0.00	
7,600.0	5.52	259.92	7,582.7	-135.5	-292.7	-133.7	0.00	0.00	0.00	
7,700.0	5.52	259.92	7,682.3	-137.2	-302.2	-135.3	0.00	0.00	0.00	
7,800.0	5.52	259.92	7,781.8	-138.9	-311.6	-137.0	0.00	0.00	0.00	
7,900.0	5.52	259.92	7,881.3	-140.6	-321.1	-138.6	0.00	0.00	0.00	
8,000.0	5.52	259.92	7,980.9	-142.3	-330.6	-140.2	0.00	0.00	0.00	
8,100.0	5.52	259.92	8,080.4	-144.0	-340.0	-141.8	0.00	0.00	0.00	
8,200.0	5.52	259.92	8,179.9	-145.6	-349.5	-143.4	0.00	0.00	0.00	
8,300.0	5.52	259.92	8,279.5	-147.3	-359.0	-145.1	0.00	0.00	0.00	
8,382.9	5.52	259.92	8,362.0	-148.7	-366.8	-146.4	0.00	0.00	0.00	
<b>G4: BSGL (CS9)</b>										
8,400.0	5.52	259.92	8,379.0	-149.0	-368.4	-146.7	0.00	0.00	0.00	
8,500.0	5.52	259.92	8,478.6	-150.7	-377.9	-148.3	0.00	0.00	0.00	
8,600.0	5.52	259.92	8,578.1	-152.4	-387.4	-149.9	0.00	0.00	0.00	
8,700.0	5.52	259.92	8,677.6	-154.1	-396.8	-151.6	0.00	0.00	0.00	
8,778.7	5.52	259.92	8,756.0	-155.4	-404.3	-152.8	0.00	0.00	0.00	
<b>L8.2: U. Avalon Shale</b>										
8,800.0	5.52	259.92	8,777.2	-155.7	-406.3	-153.2	0.00	0.00	0.00	
8,900.0	5.52	259.92	8,876.7	-157.4	-415.8	-154.8	0.00	0.00	0.00	
8,988.7	5.52	259.92	8,965.0	-158.9	-424.2	-156.3	0.00	0.00	0.00	
<b>L6.3: Avalon Carb</b>										
9,000.0	5.52	259.92	8,976.2	-159.1	-425.3	-156.4	0.00	0.00	0.00	
9,100.0	5.52	259.92	9,075.8	-160.8	-434.7	-158.1	0.00	0.00	0.00	
9,200.0	5.52	259.92	9,175.3	-162.5	-444.2	-159.7	0.00	0.00	0.00	
9,300.0	5.52	259.92	9,274.8	-164.2	-453.7	-161.3	0.00	0.00	0.00	
9,367.5	5.52	259.92	9,342.0	-165.3	-460.0	-162.4	0.00	0.00	0.00	
<b>L5.3: FBSC</b>										
9,400.0	5.52	259.92	9,374.4	-165.8	-463.1	-162.9	0.00	0.00	0.00	
9,417.7	5.52	259.92	9,392.0	-166.1	-464.8	-163.2	0.00	0.00	0.00	
<b>L5.1: FBSC</b>										
9,498.1	5.52	259.92	9,472.0	-167.5	-472.4	-164.5	0.00	0.00	0.00	
<b>M. FBSC</b>										
9,500.0	5.52	259.92	9,473.9	-167.5	-472.6	-164.6	0.00	0.00	0.00	
9,600.0	5.52	259.92	9,573.5	-169.2	-482.1	-166.2	0.00	0.00	0.00	
9,700.0	5.52	259.92	9,673.0	-170.9	-491.5	-167.8	0.00	0.00	0.00	
9,712.1	5.52	259.92	9,685.0	-171.1	-492.7	-168.0	0.00	0.00	0.00	
<b>L4.3: SBSC</b>										
9,800.0	5.52	259.92	9,772.5	-172.6	-501.0	-169.4	0.00	0.00	0.00	
9,900.0	5.52	259.92	9,872.1	-174.3	-510.5	-171.0	0.00	0.00	0.00	
10,000.0	5.52	259.92	9,971.6	-175.9	-519.9	-172.7	0.00	0.00	0.00	
10,010.4	5.52	259.92	9,982.0	-176.1	-520.9	-172.8	0.00	0.00	0.00	
<b>L4.1: SBSC</b>										
10,100.0	5.52	259.92	10,071.1	-177.6	-529.4	-174.3	0.00	0.00	0.00	
10,200.0	5.52	259.92	10,170.7	-179.3	-538.9	-175.9	0.00	0.00	0.00	
10,300.0	5.52	259.92	10,270.2	-181.0	-548.3	-177.5	0.00	0.00	0.00	
10,400.0	5.52	259.92	10,369.7	-182.7	-557.8	-179.2	0.00	0.00	0.00	
10,500.0	5.52	259.92	10,469.3	-184.4	-567.3	-180.8	0.00	0.00	0.00	
10,543.9	5.52	259.92	10,513.0	-185.1	-571.4	-181.5	0.00	0.00	0.00	
<b>L3.3: TBSC</b>										
10,600.0	5.52	259.92	10,568.8	-186.0	-576.7	-182.4	0.00	0.00	0.00	
10,651.1	5.52	259.92	10,619.7	-186.9	-581.6	-183.2	0.00	0.00	0.00	
<b>Start Drop -1.50</b>										

Planning Report

<b>Database:</b>	EDM 5000.14 Single User Db	<b>Local Co-ordinate Reference:</b>	Well Susan Lancaster Fed Com #202H
<b>Company:</b>	Matador Production Company	<b>TVD Reference:</b>	KB @ 3660.5usft
<b>Project:</b>	Ranger/Arrowhead	<b>MD Reference:</b>	KB @ 3660.5usft
<b>Site:</b>	Susan Lancaster	<b>North Reference:</b>	Grid
<b>Well:</b>	Susan Lancaster Fed Com #202H	<b>Survey Calculation Method:</b>	Minimum Curvature
<b>Wellbore:</b>	Wellbore #1		
<b>Design:</b>	BLM Plan #1		

Planned Survey									
Measured Depth (usft)	Inclination (°)	Azimuth (°)	Vertical Depth (usft)	+N/-S (usft)	+E/-W (usft)	Vertical Section (usft)	Dogleg Rate (°/100usft)	Build Rate (°/100usft)	Turn Rate (°/100usft)
10,700.0	4.78	259.92	10,668.4	-187.7	-585.9	-184.0	1.50	-1.50	0.00
10,800.0	3.28	259.92	10,768.1	-188.9	-592.8	-185.2	1.50	-1.50	0.00
10,900.0	1.78	259.92	10,868.0	-189.7	-597.2	-185.9	1.50	-1.50	0.00
11,000.0	0.28	259.92	10,968.0	-190.0	-599.0	-186.2	1.50	-1.50	0.00
11,019.0	0.00	0.00	10,987.0	-190.0	-599.0	-186.2	1.50	-1.50	0.00
<b>Start Build 10.00 - KOP - Susan Lancaster Fed Com #202H</b>									
11,039.0	2.00	359.64	11,007.0	-189.7	-599.0	-185.9	10.00	10.00	0.00
<b>L3.1: TBSG</b>									
11,100.0	8.10	359.64	11,067.7	-184.3	-599.0	-180.5	10.00	10.00	0.00
11,200.0	18.10	359.64	11,165.0	-161.6	-599.2	-157.9	10.00	10.00	0.00
11,300.0	28.10	359.64	11,256.9	-122.5	-599.4	-118.7	10.00	10.00	0.00
11,400.0	38.10	359.64	11,340.5	-67.9	-599.8	-64.1	10.00	10.00	0.00
11,500.0	48.10	359.64	11,413.5	0.3	-600.2	4.1	10.00	10.00	0.00
11,591.7	57.27	359.64	11,469.0	73.2	-600.7	77.0	10.00	10.00	0.00
<b>L2: WFMP A</b>									
11,600.0	58.10	359.64	11,473.4	80.2	-600.7	84.0	10.00	10.00	0.00
11,700.0	68.10	359.64	11,518.6	169.3	-601.3	173.0	10.00	10.00	0.00
11,800.0	78.10	359.64	11,547.6	264.8	-601.9	268.6	10.00	10.00	0.00
11,900.0	88.10	359.64	11,559.6	364.0	-602.5	367.7	10.00	10.00	0.00
11,909.0	89.01	359.64	11,559.9	373.0	-602.5	376.8	10.00	10.00	0.00
<b>FPP - Susan Lancaster Fed Com #202H</b>									
11,919.0	90.00	359.64	11,560.0	382.9	-602.6	386.7	10.00	10.00	0.00
<b>Start 5500.0 hold at 11919.0 MD</b>									
12,000.0	90.00	359.64	11,560.0	464.0	-603.1	467.7	0.00	0.00	0.00
12,100.0	90.00	359.64	11,560.0	564.0	-603.7	567.7	0.00	0.00	0.00
12,200.0	90.00	359.64	11,560.0	664.0	-604.4	667.7	0.00	0.00	0.00
12,300.0	90.00	359.64	11,560.0	764.0	-605.0	767.7	0.00	0.00	0.00
12,400.0	90.00	359.64	11,560.0	864.0	-605.6	867.7	0.00	0.00	0.00
12,500.0	90.00	359.64	11,560.0	964.0	-606.3	967.7	0.00	0.00	0.00
12,600.0	90.00	359.64	11,560.0	1,063.9	-606.9	1,067.7	0.00	0.00	0.00
12,700.0	90.00	359.64	11,560.0	1,163.9	-607.5	1,167.7	0.00	0.00	0.00
12,800.0	90.00	359.64	11,560.0	1,263.9	-608.1	1,267.7	0.00	0.00	0.00
12,900.0	90.00	359.64	11,560.0	1,363.9	-608.8	1,367.7	0.00	0.00	0.00
13,000.0	90.00	359.64	11,560.0	1,463.9	-609.4	1,467.7	0.00	0.00	0.00
13,100.0	90.00	359.64	11,560.0	1,563.9	-610.0	1,567.7	0.00	0.00	0.00
13,200.0	90.00	359.64	11,560.0	1,663.9	-610.6	1,667.7	0.00	0.00	0.00
13,300.0	90.00	359.64	11,560.0	1,763.9	-611.3	1,767.7	0.00	0.00	0.00
13,400.0	90.00	359.64	11,560.0	1,863.9	-611.9	1,867.7	0.00	0.00	0.00
13,500.0	90.00	359.64	11,560.0	1,963.9	-612.5	1,967.7	0.00	0.00	0.00
13,600.0	90.00	359.64	11,560.0	2,063.9	-613.2	2,067.7	0.00	0.00	0.00
13,700.0	90.00	359.64	11,560.0	2,163.9	-613.8	2,167.7	0.00	0.00	0.00
13,800.0	90.00	359.64	11,560.0	2,263.9	-614.4	2,267.7	0.00	0.00	0.00
13,900.0	90.00	359.64	11,560.0	2,363.9	-615.0	2,367.7	0.00	0.00	0.00
14,000.0	90.00	359.64	11,560.0	2,463.9	-615.7	2,467.7	0.00	0.00	0.00
14,100.0	90.00	359.64	11,560.0	2,563.9	-616.3	2,567.7	0.00	0.00	0.00
14,200.0	90.00	359.64	11,560.0	2,663.9	-616.9	2,667.7	0.00	0.00	0.00
14,300.0	90.00	359.64	11,560.0	2,763.9	-617.6	2,767.7	0.00	0.00	0.00
14,400.0	90.00	359.64	11,560.0	2,863.9	-618.2	2,867.7	0.00	0.00	0.00
14,500.0	90.00	359.64	11,560.0	2,963.9	-618.8	2,967.7	0.00	0.00	0.00
14,600.0	90.00	359.64	11,560.0	3,063.9	-619.4	3,067.7	0.00	0.00	0.00
14,700.0	90.00	359.64	11,560.0	3,163.9	-620.1	3,167.7	0.00	0.00	0.00
14,800.0	90.00	359.64	11,560.0	3,263.9	-620.7	3,267.7	0.00	0.00	0.00
14,900.0	90.00	359.64	11,560.0	3,363.9	-621.3	3,367.7	0.00	0.00	0.00

Planning Report

<b>Database:</b>	EDM 5000.14 Single User Db	<b>Local Co-ordinate Reference:</b>	Well Susan Lancaster Fed Com #202H
<b>Company:</b>	Matador Production Company	<b>TVD Reference:</b>	KB @ 3660.5usft
<b>Project:</b>	Ranger/Arrowhead	<b>MD Reference:</b>	KB @ 3660.5usft
<b>Site:</b>	Susan Lancaster	<b>North Reference:</b>	Grid
<b>Well:</b>	Susan Lancaster Fed Com #202H	<b>Survey Calculation Method:</b>	Minimum Curvature
<b>Wellbore:</b>	Wellbore #1		
<b>Design:</b>	BLM Plan #1		

Planned Survey										
Measured Depth (usft)	Inclination (°)	Azimuth (°)	Vertical Depth (usft)	+N/-S (usft)	+E/-W (usft)	Vertical Section (usft)	Dogleg Rate (°/100usft)	Build Rate (°/100usft)	Turn Rate (°/100usft)	
15,000.0	90.00	359.64	11,560.0	3,463.9	-622.0	3,467.7	0.00	0.00	0.00	
15,100.0	90.00	359.64	11,560.0	3,563.9	-622.6	3,567.7	0.00	0.00	0.00	
15,200.0	90.00	359.64	11,560.0	3,663.9	-623.2	3,667.7	0.00	0.00	0.00	
15,300.0	90.00	359.64	11,560.0	3,763.9	-623.8	3,767.7	0.00	0.00	0.00	
15,400.0	90.00	359.64	11,560.0	3,863.9	-624.5	3,867.7	0.00	0.00	0.00	
15,500.0	90.00	359.64	11,560.0	3,963.9	-625.1	3,967.7	0.00	0.00	0.00	
15,600.0	90.00	359.64	11,560.0	4,063.9	-625.7	4,067.7	0.00	0.00	0.00	
15,700.0	90.00	359.64	11,560.0	4,163.9	-626.4	4,167.7	0.00	0.00	0.00	
15,800.0	90.00	359.64	11,560.0	4,263.9	-627.0	4,267.7	0.00	0.00	0.00	
15,900.0	90.00	359.64	11,560.0	4,363.9	-627.6	4,367.7	0.00	0.00	0.00	
16,000.0	90.00	359.64	11,560.0	4,463.9	-628.2	4,467.7	0.00	0.00	0.00	
16,100.0	90.00	359.64	11,560.0	4,563.9	-628.9	4,567.7	0.00	0.00	0.00	
16,200.0	90.00	359.64	11,560.0	4,663.9	-629.5	4,667.7	0.00	0.00	0.00	
16,300.0	90.00	359.64	11,560.0	4,763.9	-630.1	4,767.7	0.00	0.00	0.00	
16,400.0	90.00	359.64	11,560.0	4,863.9	-630.8	4,867.7	0.00	0.00	0.00	
16,500.0	90.00	359.64	11,560.0	4,963.9	-631.4	4,967.7	0.00	0.00	0.00	
16,600.0	90.00	359.64	11,560.0	5,063.9	-632.0	5,067.7	0.00	0.00	0.00	
16,700.0	90.00	359.64	11,560.0	5,163.9	-632.6	5,167.7	0.00	0.00	0.00	
16,800.0	90.00	359.64	11,560.0	5,263.9	-633.3	5,267.7	0.00	0.00	0.00	
16,900.0	90.00	359.64	11,560.0	5,363.9	-633.9	5,367.7	0.00	0.00	0.00	
17,000.0	90.00	359.64	11,560.0	5,463.9	-634.5	5,467.7	0.00	0.00	0.00	
17,090.1	90.00	359.64	11,560.0	5,554.0	-635.1	5,557.9	0.00	0.00	0.00	
<b>BPP1 - Susan Lancaster Fed Com #202H</b>										
17,100.0	90.00	359.64	11,560.0	5,563.9	-635.2	5,567.7	0.00	0.00	0.00	
17,200.0	90.00	359.64	11,560.0	5,663.9	-635.8	5,667.7	0.00	0.00	0.00	
17,300.0	90.00	359.64	11,560.0	5,763.9	-636.4	5,767.7	0.00	0.00	0.00	
17,400.0	90.00	359.64	11,560.0	5,863.9	-637.0	5,867.7	0.00	0.00	0.00	
17,419.0	90.00	359.64	11,560.0	5,882.8	-637.2	5,886.7	0.00	0.00	0.00	
<b>Start DLS 2.00 TFO -90.00</b>										
17,500.0	90.00	358.02	11,560.0	5,963.8	-638.8	5,967.7	2.00	0.00	-2.00	
17,600.0	90.00	356.02	11,560.0	6,063.7	-644.0	6,067.6	2.00	0.00	-2.00	
17,700.0	90.00	354.02	11,560.0	6,163.3	-652.7	6,167.3	2.00	0.00	-2.00	
17,800.0	90.00	352.02	11,560.0	6,262.6	-664.8	6,266.6	2.00	0.00	-2.00	
17,900.0	90.00	350.02	11,560.0	6,361.3	-680.5	6,365.5	2.00	0.00	-2.00	
18,000.0	90.00	348.02	11,560.0	6,459.5	-699.5	6,463.8	2.00	0.00	-2.00	
18,100.0	90.00	346.02	11,560.0	6,556.9	-722.0	6,561.3	2.00	0.00	-2.00	
18,200.0	90.00	344.02	11,560.0	6,653.5	-747.8	6,658.1	2.00	0.00	-2.00	
18,300.0	90.00	342.02	11,560.0	6,749.2	-777.0	6,753.9	2.00	0.00	-2.00	
18,400.0	90.00	340.02	11,560.0	6,843.7	-809.5	6,848.7	2.00	0.00	-2.00	
18,500.0	90.00	338.02	11,560.0	6,937.1	-845.3	6,942.3	2.00	0.00	-2.00	
18,542.0	90.00	337.18	11,560.0	6,975.9	-861.3	6,981.2	2.00	0.00	-2.00	
<b>Start DLS 2.00 TFO 90.09</b>										
18,600.0	90.00	338.34	11,560.0	7,029.6	-883.3	7,035.0	2.00	0.00	2.00	
18,700.0	89.99	340.34	11,560.0	7,123.2	-918.6	7,128.8	2.00	0.00	2.00	
18,800.0	89.99	342.34	11,560.0	7,217.9	-950.6	7,223.7	2.00	0.00	2.00	
18,900.0	89.99	344.34	11,560.0	7,313.7	-979.2	7,319.7	2.00	0.00	2.00	
19,000.0	89.99	346.34	11,560.0	7,410.4	-1,004.5	7,416.6	2.00	0.00	2.00	
19,100.0	89.98	348.34	11,560.0	7,508.0	-1,026.5	7,514.3	2.00	0.00	2.00	
19,131.4	89.98	348.97	11,560.1	7,538.8	-1,032.6	7,545.2	2.00	0.00	2.00	
<b>DP1 - Susan Lancaster Fed Com #202H</b>										
19,200.0	89.98	350.34	11,560.1	7,606.3	-1,044.9	7,612.7	2.00	0.00	2.00	
19,300.0	89.98	352.34	11,560.1	7,705.1	-1,060.0	7,711.6	2.00	0.00	2.00	
19,400.0	89.97	354.34	11,560.2	7,804.5	-1,071.6	7,811.0	2.00	0.00	2.00	

Planning Report

<b>Database:</b>	EDM 5000.14 Single User Db	<b>Local Co-ordinate Reference:</b>	Well Susan Lancaster Fed Com #202H
<b>Company:</b>	Matador Production Company	<b>TVD Reference:</b>	KB @ 3660.5usft
<b>Project:</b>	Ranger/Arrowhead	<b>MD Reference:</b>	KB @ 3660.5usft
<b>Site:</b>	Susan Lancaster	<b>North Reference:</b>	Grid
<b>Well:</b>	Susan Lancaster Fed Com #202H	<b>Survey Calculation Method:</b>	Minimum Curvature
<b>Wellbore:</b>	Wellbore #1		
<b>Design:</b>	BLM Plan #1		

Planned Survey										
Measured Depth (usft)	Inclination (°)	Azimuth (°)	Vertical Depth (usft)	+N/-S (usft)	+E/-W (usft)	Vertical Section (usft)	Dogleg Rate (°/100usft)	Build Rate (°/100usft)	Turn Rate (°/100usft)	
19,500.0	89.97	356.34	11,560.2	7,904.1	-1,079.7	7,910.8	2.00	0.00	2.00	
19,600.0	89.97	358.34	11,560.3	8,004.0	-1,084.4	8,010.7	2.00	0.00	2.00	
19,669.3	89.96	359.73	11,560.3	8,073.3	-1,085.5	8,080.0	2.00	0.00	2.00	
<b>Start 2722.9 hold at 19669.3 MD</b>										
19,700.0	89.96	359.73	11,560.3	8,104.0	-1,085.7	8,110.7	0.00	0.00	0.00	
19,749.0	89.96	359.73	11,560.4	8,153.0	-1,085.9	8,159.7	0.00	0.00	0.00	
<b>DP2 - Susan Lancaster Fed Com #202H</b>										
19,800.0	89.96	359.73	11,560.4	8,204.0	-1,086.2	8,210.7	0.00	0.00	0.00	
19,866.0	89.96	359.73	11,560.4	8,270.0	-1,086.5	8,276.7	0.00	0.00	0.00	
<b>BPP2 - Susan Lancaster Fed Com #202H</b>										
19,900.0	89.96	359.73	11,560.5	8,304.0	-1,086.6	8,310.7	0.00	0.00	0.00	
20,000.0	89.96	359.73	11,560.5	8,404.0	-1,087.1	8,410.7	0.00	0.00	0.00	
20,100.0	89.96	359.73	11,560.6	8,504.0	-1,087.6	8,510.7	0.00	0.00	0.00	
20,200.0	89.96	359.73	11,560.6	8,604.0	-1,088.1	8,610.7	0.00	0.00	0.00	
20,300.0	89.96	359.73	11,560.7	8,704.0	-1,088.5	8,710.7	0.00	0.00	0.00	
20,400.0	89.96	359.73	11,560.8	8,804.0	-1,089.0	8,810.7	0.00	0.00	0.00	
20,500.0	89.96	359.73	11,560.8	8,904.0	-1,089.5	8,910.7	0.00	0.00	0.00	
20,600.0	89.96	359.73	11,560.9	9,004.0	-1,090.0	9,010.7	0.00	0.00	0.00	
20,700.0	89.96	359.73	11,561.0	9,104.0	-1,090.5	9,110.7	0.00	0.00	0.00	
20,800.0	89.96	359.73	11,561.0	9,204.0	-1,090.9	9,210.7	0.00	0.00	0.00	
20,900.0	89.96	359.73	11,561.1	9,304.0	-1,091.4	9,310.7	0.00	0.00	0.00	
21,000.0	89.96	359.73	11,561.1	9,404.0	-1,091.9	9,410.7	0.00	0.00	0.00	
21,100.0	89.96	359.73	11,561.2	9,504.0	-1,092.4	9,510.7	0.00	0.00	0.00	
21,200.0	89.96	359.73	11,561.3	9,604.0	-1,092.8	9,610.7	0.00	0.00	0.00	
21,300.0	89.96	359.73	11,561.3	9,704.0	-1,093.3	9,710.7	0.00	0.00	0.00	
21,400.0	89.96	359.73	11,561.4	9,804.0	-1,093.8	9,810.7	0.00	0.00	0.00	
21,500.0	89.96	359.73	11,561.4	9,904.0	-1,094.3	9,910.7	0.00	0.00	0.00	
21,600.0	89.96	359.73	11,561.5	10,004.0	-1,094.8	10,010.7	0.00	0.00	0.00	
21,700.0	89.96	359.73	11,561.6	10,104.0	-1,095.2	10,110.7	0.00	0.00	0.00	
21,800.0	89.96	359.73	11,561.6	10,204.0	-1,095.7	10,210.7	0.00	0.00	0.00	
21,900.0	89.96	359.73	11,561.7	10,304.0	-1,096.2	10,310.7	0.00	0.00	0.00	
22,000.0	89.96	359.73	11,561.8	10,404.0	-1,096.7	10,410.7	0.00	0.00	0.00	
22,100.0	89.96	359.73	11,561.8	10,504.0	-1,097.1	10,510.7	0.00	0.00	0.00	
22,200.0	89.96	359.73	11,561.9	10,604.0	-1,097.6	10,610.7	0.00	0.00	0.00	
22,300.0	89.96	359.73	11,561.9	10,704.0	-1,098.1	10,710.7	0.00	0.00	0.00	
22,392.2	89.96	359.73	11,562.0	10,796.2	-1,098.5	10,802.9	0.00	0.00	0.00	
<b>TD at 22392.2 - BHL - Susan Lancaster Fed Com #202H</b>										

Planning Report

<b>Database:</b>	EDM 5000.14 Single User Db	<b>Local Co-ordinate Reference:</b>	Well Susan Lancaster Fed Com #202H
<b>Company:</b>	Matador Production Company	<b>TVD Reference:</b>	KB @ 3660.5usft
<b>Project:</b>	Ranger/Arrowhead	<b>MD Reference:</b>	KB @ 3660.5usft
<b>Site:</b>	Susan Lancaster	<b>North Reference:</b>	Grid
<b>Well:</b>	Susan Lancaster Fed Com #202H	<b>Survey Calculation Method:</b>	Minimum Curvature
<b>Wellbore:</b>	Wellbore #1		
<b>Design:</b>	BLM Plan #1		

Design Targets									
Target Name - hit/miss target - Shape	Dip Angle (°)	Dip Dir. (°)	TVD (usft)	+N/-S (usft)	+E/-W (usft)	Northing (usft)	Easting (usft)	Latitude	Longitude
KOP - Susan Lancaster - plan hits target center - Point	0.00	0.00	10,987.0	-190.0	-599.0	545,792.00	689,435.00	32° 29' 56.373 N	103° 43' 8.027 W
FPP - Susan Lancaster I - plan hits target center - Point	0.00	0.00	11,559.9	373.0	-602.5	546,355.00	689,431.46	32° 30' 1.944 N	103° 43' 8.031 W
BPP1 - Susan Lancaster - plan hits target center - Point	0.00	0.00	11,560.0	5,554.0	-635.1	551,536.00	689,398.90	32° 30' 53.214 N	103° 43' 8.062 W
DP1 - Susan Lancaster I - plan misses target center by 395.5usft at 19126.7usft MD (11560.1 TVD, 7534.2 N, -1031.7 E) - Point	0.00	0.00	11,560.0	7,612.0	-644.0	553,594.00	689,390.00	32° 31' 13.579 N	103° 43' 8.028 W
BPP2 - Susan Lancaster - plan hits target center - Point	0.00	0.00	11,560.4	8,270.0	-1,086.5	554,252.00	688,947.52	32° 31' 20.115 N	103° 43' 13.151 W
BHL - Susan Lancaster I - plan hits target center - Point	0.00	0.00	11,562.0	10,796.2	-1,098.5	556,778.18	688,935.46	32° 31' 45.114 N	103° 43' 13.122 W
DP2 - Susan Lancaster I - plan misses target center by 1.9usft at 19749.0usft MD (11560.4 TVD, 8153.0 N, -1085.9 E) - Point	0.00	0.00	11,562.0	8,153.0	-1,085.0	554,135.00	688,949.00	32° 31' 18.958 N	103° 43' 13.142 W

Formations					
Measured Depth (usft)	Vertical Depth (usft)	Name	Lithology	Dip (°)	Dip Direction (°)
1,045.0	1,045.0	Rustler		0.00	359.64
1,460.4	1,460.0	Salado		0.00	359.64
2,916.4	2,916.0	G30:CS14-CSB (Lamar/Tansil)		0.00	359.64
3,295.4	3,295.0	Capitan		0.00	359.64
4,572.4	4,569.0	G25: Bell Cyn		0.00	359.64
5,113.8	5,108.0	G13: Cherry Cyn.		0.00	359.64
6,643.8	6,631.0	G7: Brushy Cyn.		0.00	359.64
8,382.9	8,362.0	G4: BSG (CS9)		0.00	359.64
8,778.7	8,756.0	L8.2: U. Avalon Shale		0.00	359.64
8,988.7	8,965.0	L6.3: Avalon Carb		0.00	359.64
9,367.5	9,342.0	L5.3: FBSC		0.00	359.64
9,417.7	9,392.0	L5.1: FBSG		0.00	359.64
9,498.1	9,472.0	M. FBSG		0.00	359.64
9,712.1	9,685.0	L4.3: SBSC		0.00	359.64
10,010.4	9,982.0	L4.1: SBSG		0.00	359.64
10,543.9	10,513.0	L3.3: TBSC		0.00	359.64
11,039.0	11,007.0	L3.1: TBSC		0.00	359.64
11,591.7	11,469.0	L2: WFMP A		0.00	359.64

Planning Report

<b>Database:</b>	EDM 5000.14 Single User Db	<b>Local Co-ordinate Reference:</b>	Well Susan Lancaster Fed Com #202H
<b>Company:</b>	Matador Production Company	<b>TVD Reference:</b>	KB @ 3660.5usft
<b>Project:</b>	Ranger/Arrowhead	<b>MD Reference:</b>	KB @ 3660.5usft
<b>Site:</b>	Susan Lancaster	<b>North Reference:</b>	Grid
<b>Well:</b>	Susan Lancaster Fed Com #202H	<b>Survey Calculation Method:</b>	Minimum Curvature
<b>Wellbore:</b>	Wellbore #1		
<b>Design:</b>	BLM Plan #1		

Plan Annotations					
Measured Depth (usft)	Vertical Depth (usft)	Local Coordinates		Comment	
		+N/-S (usft)	+E/-W (usft)		
993.6	993.6	0.0	0.0	Start Build 2.00	
1,193.6	1,193.4	-6.9	-1.2	Start Drop -1.50	
1,460.3	1,459.9	-16.0	-2.8	Start 1840.1 hold at 1460.3 MD	
3,300.4	3,300.0	-16.0	-2.8	Start Build 2.00	
3,600.4	3,599.5	-31.7	-2.8	Start 300.0 hold at 3600.4 MD	
3,900.4	3,897.8	-63.1	-2.8	Start Drop -1.50	
4,300.4	4,297.1	-84.0	-2.8	Start 100.0 hold at 4300.4 MD	
4,400.4	4,397.1	-84.0	-2.8	Start Build 2.00	
4,676.3	4,672.6	-86.3	-15.9	Start 5974.8 hold at 4676.3 MD	
10,651.1	10,619.7	-186.9	-581.6	Start Drop -1.50	
11,019.0	10,987.0	-190.0	-599.0	Start Build 10.00	
11,919.0	11,560.0	382.9	-602.6	Start 5500.0 hold at 11919.0 MD	
17,419.0	11,560.0	5,882.8	-637.2	Start DLS 2.00 TFO -90.00	
18,542.0	11,560.0	6,975.9	-861.3	Start DLS 2.00 TFO 90.09	
19,669.3	11,560.3	8,073.3	-1,085.5	Start 2722.9 hold at 19669.3 MD	
22,392.2	11,562.0	10,796.2	-1,098.5	TD at 22392.2	

# **Matador Production Company**

**Ranger/Arrowhead**

**Susan Lancaster**

**Susan Lancaster Fed Com #202H**

**Wellbore #1**

**BLM Plan #1**

## **Anticollision Summary Report**

**04 February, 2026**

Anticollision Summary Report

<b>Company:</b>	Matador Production Company	<b>Local Co-ordinate Reference:</b>	Well Susan Lancaster Fed Com #202H
<b>Project:</b>	Ranger/Arrowhead	<b>TVD Reference:</b>	KB @ 3660.5usft
<b>Reference Site:</b>	Susan Lancaster	<b>MD Reference:</b>	KB @ 3660.5usft
<b>Site Error:</b>	0.0 usft	<b>North Reference:</b>	Grid
<b>Reference Well:</b>	Susan Lancaster Fed Com #202H	<b>Survey Calculation Method:</b>	Minimum Curvature
<b>Well Error:</b>	0.0 usft	<b>Output errors are at</b>	2.00 sigma
<b>Reference Wellbore</b>	Wellbore #1	<b>Database:</b>	EDM 5000.14 Single User Db
<b>Reference Design:</b>	BLM Plan #1	<b>Offset TVD Reference:</b>	Offset Datum

<b>Reference</b>	BLM Plan #1		
<b>Filter type:</b>	NO GLOBAL FILTER: Using user defined selection & filtering criteria		
<b>Interpolation Method:</b>	Stations	<b>Error Model:</b>	ISCWSA
<b>Depth Range:</b>	Unlimited	<b>Scan Method:</b>	Closest Approach 3D
<b>Results Limited by:</b>	Maximum center-center distance of 10,000.0 usft	<b>Error Surface:</b>	Pedal Curve
<b>Warning Levels Evaluated at:</b>	2.00 Sigma	<b>Casing Method:</b>	Not applied

<b>Survey Tool Program</b>	<b>Date</b>	2/4/2026		
<b>From (usft)</b>	<b>To (usft)</b>	<b>Survey (Wellbore)</b>	<b>Tool Name</b>	<b>Description</b>
0.0	22,392.1	BLM Plan #1 (Wellbore #1)	MWD	OWSG MWD - Standard

Summary						
Site Name	Reference Measured Depth (usft)	Offset Measured Depth (usft)	Distance Between Centres (usft)	Distance Between Ellipses (usft)	Separation Factor	Warning
Offset Well - Wellbore - Design						
Susan Lancaster						
Susan Lancaster Fed Com #101H - Wellbore #1 - BLM P	2,900.0	2,896.6	529.0	508.8	26.213	CC, ES
Susan Lancaster Fed Com #101H - Wellbore #1 - BLM P	22,392.2	20,202.5	3,139.1	2,884.6	12.331	SF
Susan Lancaster Fed Com #102H - Wellbore #1 - BLM P	3,006.4	3,004.0	499.2	478.2	23.832	CC
Susan Lancaster Fed Com #102H - Wellbore #1 - BLM P	3,100.0	3,094.1	499.3	477.7	23.120	ES
Susan Lancaster Fed Com #102H - Wellbore #1 - BLM P	8,800.0	8,788.3	622.3	560.5	10.062	SF
Susan Lancaster Fed Com #111H - Wellbore #1 - BLM P	2,900.0	2,901.4	419.5	399.3	20.771	CC, ES
Susan Lancaster Fed Com #111H - Wellbore #1 - BLM P	22,392.2	20,694.9	2,688.7	2,413.8	9.781	SF
Susan Lancaster Fed Com #112H - Wellbore #1 - BLM P	2,900.0	2,901.4	389.8	369.6	19.297	CC
Susan Lancaster Fed Com #112H - Wellbore #1 - BLM P	9,175.9	9,142.3	397.3	332.8	6.164	ES
Susan Lancaster Fed Com #112H - Wellbore #1 - BLM P	9,200.0	9,160.8	397.5	333.0	6.158	SF
Susan Lancaster Fed Com #121H - Wellbore #1 - BLM P	2,900.0	2,896.6	417.3	397.1	20.678	CC, ES
Susan Lancaster Fed Com #121H - Wellbore #1 - BLM P	22,392.2	21,332.6	2,114.3	1,798.7	6.698	SF
Susan Lancaster Fed Com #122H - Wellbore #1 - BLM P	9,927.1	9,892.4	282.7	212.9	4.051	CC, ES, SF
Susan Lancaster Fed Com #131H - Wellbore #1 - BLM P	993.6	1,004.4	114.0	107.3	17.005	CC
Susan Lancaster Fed Com #131H - Wellbore #1 - BLM P	3,559.5	3,572.4	122.0	97.1	4.909	ES
Susan Lancaster Fed Com #131H - Wellbore #1 - BLM P	3,700.0	3,714.0	124.7	98.8	4.823	SF
Susan Lancaster Fed Com #132H - Wellbore #1 - BLM P	4,518.4	4,533.8	134.8	103.1	4.252	CC
Susan Lancaster Fed Com #132H - Wellbore #1 - BLM P	19,700.0	19,580.6	204.6	0.9	1.004	Level 2, ES, SF
Susan Lancaster Fed Com #141H - Wellbore #1 - BLM P	2,901.3	2,901.0	527.3	507.1	26.102	CC
Susan Lancaster Fed Com #141H - Wellbore #1 - BLM P	3,000.0	2,988.7	527.8	506.9	25.301	ES
Susan Lancaster Fed Com #141H - Wellbore #1 - BLM P	22,392.2	20,970.6	2,370.8	2,076.8	8.065	SF
Susan Lancaster Fed Com #142H - Wellbore #1 - BLM P	9,657.9	9,640.3	448.5	380.7	6.615	CC, ES
Susan Lancaster Fed Com #142H - Wellbore #1 - BLM P	9,700.0	9,670.2	449.3	381.4	6.615	SF
Susan Lancaster Fed Com #151H - Wellbore #1 - BLM P	993.6	1,005.4	29.9	23.2	4.453	CC, ES
Susan Lancaster Fed Com #151H - Wellbore #1 - BLM P	3,000.0	3,000.0	46.5	25.6	2.223	SF
Susan Lancaster Fed Com #152H - Wellbore #1 - BLM P	3,385.8	3,388.1	37.6	14.0	1.594	CC
Susan Lancaster Fed Com #152H - Wellbore #1 - BLM P	3,400.0	3,402.3	37.7	14.0	1.590	ES, SF
Susan Lancaster Fed Com #201H - Wellbore #1 - BLM P	993.6	1,005.4	109.9	103.2	16.392	CC
Susan Lancaster Fed Com #201H - Wellbore #1 - BLM P	3,803.5	3,810.1	112.9	86.3	4.256	ES
Susan Lancaster Fed Com #201H - Wellbore #1 - BLM P	22,392.2	22,664.1	1,322.3	951.6	3.567	SF
Susan Lancaster Fed Com #241H - Wellbore #1 - BLM P	4,384.8	4,404.2	92.7	61.9	3.015	CC, ES
Susan Lancaster Fed Com #241H - Wellbore #1 - BLM P	4,400.4	4,410.7	92.8	62.0	3.011	SF
Susan Lancaster Fed Com #242H - Wellbore #1 - BLM P	993.6	1,004.4	30.0	23.3	4.472	CC
Susan Lancaster Fed Com #242H - Wellbore #1 - BLM P	10,900.0	10,907.6	89.4	12.3	1.160	Level 2, ES, SF

CC - Min centre to center distance or convergent point, SF - min separation factor, ES - min ellipse separation

Anticollision Summary Report

<b>Company:</b>	Matador Production Company	<b>Local Co-ordinate Reference:</b>	Well Susan Lancaster Fed Com #202H
<b>Project:</b>	Ranger/Arrowhead	<b>TVD Reference:</b>	KB @ 3660.5usft
<b>Reference Site:</b>	Susan Lancaster	<b>MD Reference:</b>	KB @ 3660.5usft
<b>Site Error:</b>	0.0 usft	<b>North Reference:</b>	Grid
<b>Reference Well:</b>	Susan Lancaster Fed Com #202H	<b>Survey Calculation Method:</b>	Minimum Curvature
<b>Well Error:</b>	0.0 usft	<b>Output errors are at</b>	2.00 sigma
<b>Reference Wellbore</b>	Wellbore #1	<b>Database:</b>	EDM 5000.14 Single User Db
<b>Reference Design:</b>	BLM Plan #1	<b>Offset TVD Reference:</b>	Offset Datum

Reference Depths are relative to KB @ 3660.5usft  
 Offset Depths are relative to Offset Datum  
 Central Meridian is 104° 20' 0.000 W

Coordinates are relative to: Susan Lancaster Fed Com #202H  
 Coordinate System is US State Plane 1927 (Exact solution), New Mexico East 30  
 Grid Convergence at Surface is: 0.33°

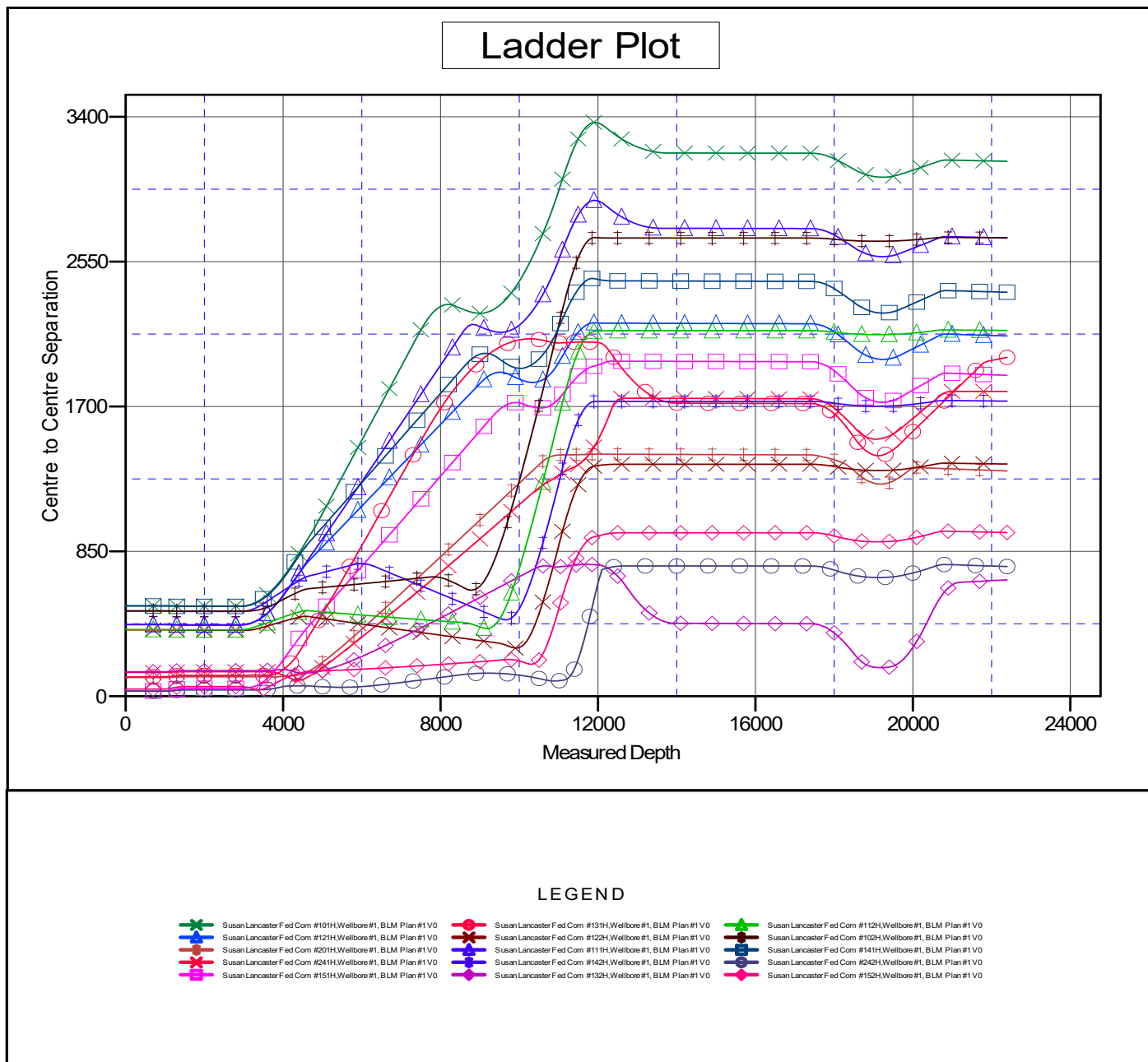

CC - Min centre to center distance or convergent point, SF - min separation factor, ES - min ellipse separation

Anticollision Summary Report

<b>Company:</b>	Matador Production Company	<b>Local Co-ordinate Reference:</b>	Well Susan Lancaster Fed Com #202H
<b>Project:</b>	Ranger/Arrowhead	<b>TVD Reference:</b>	KB @ 3660.5usft
<b>Reference Site:</b>	Susan Lancaster	<b>MD Reference:</b>	KB @ 3660.5usft
<b>Site Error:</b>	0.0 usft	<b>North Reference:</b>	Grid
<b>Reference Well:</b>	Susan Lancaster Fed Com #202H	<b>Survey Calculation Method:</b>	Minimum Curvature
<b>Well Error:</b>	0.0 usft	<b>Output errors are at</b>	2.00 sigma
<b>Reference Wellbore</b>	Wellbore #1	<b>Database:</b>	EDM 5000.14 Single User Db
<b>Reference Design:</b>	BLM Plan #1	<b>Offset TVD Reference:</b>	Offset Datum

Reference Depths are relative to KB @ 3660.5usft  
 Offset Depths are relative to Offset Datum  
 Central Meridian is 104° 20' 0.000 W

Coordinates are relative to: Susan Lancaster Fed Com #202H  
 Coordinate System is US State Plane 1927 (Exact solution), New Mexico East 30  
 Grid Convergence at Surface is: 0.33°

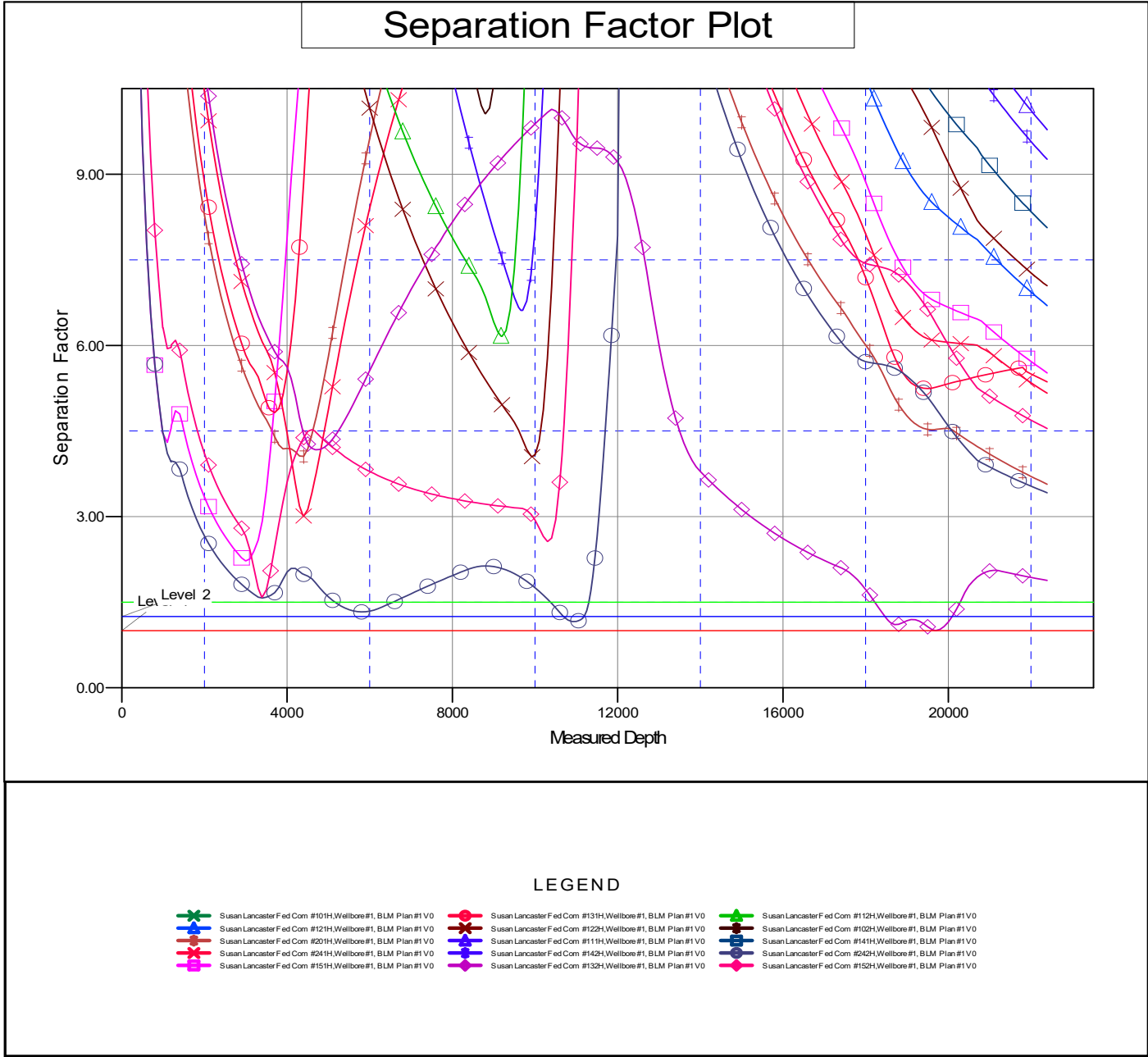

CC - Min centre to center distance or convergent point, SF - min separation factor, ES - min ellipse separation

Sante Fe Main Office  
Phone: (505) 476-3441

General Information  
Phone: (505) 629-6116

Online Phone Directory  
<https://www.emnrd.nm.gov/ocd/contact-us>

**State of New Mexico**  
**Energy, Minerals and Natural Resources**  
**Oil Conservation Division**  
**1220 S. St Francis Dr.**  
**Santa Fe, NM 87505**

CONDITIONS

Action 560695

**CONDITIONS**

Operator: MATADOR PRODUCTION COMPANY One Lincoln Centre Dallas, TX 75240	OGRID: 228937
	Action Number: 560695
	Action Type: [C-103] NOI Change of Plans (C-103A)

**CONDITIONS**

Created By	Condition	Condition Date
matthew.gomez	All previous COA's still apply.	3/20/2026