

Form 3160-3  
(October 2024)

FORM APPROVED  
OMB No. 1004-0220  
Expires: October 31, 2027

UNITED STATES  
DEPARTMENT OF THE INTERIOR  
BUREAU OF LAND MANAGEMENT  
**APPLICATION FOR PERMIT TO DRILL OR REENTER**

1a. Type of work: <input type="checkbox"/> DRILL <input type="checkbox"/> REENTER		5. Lease Serial No.
1b. Type of Well: <input type="checkbox"/> Oil Well <input type="checkbox"/> Gas Well <input type="checkbox"/> Other		6. If Indian, Allottee or Tribe Name
1c. Type of Completion: <input type="checkbox"/> Hydraulic Fracturing <input type="checkbox"/> Single Zone <input type="checkbox"/> Multiple Zone		7. If Unit or CA Agreement, Name and No.
2. Name of Operator		8. Lease Name and Well No.
3a. Address		9. API Well No. <span style="color: red;">30-043-21550</span>
3b. Phone No. (include area code)		10. Field and Pool, or Exploratory
4. Location of Well (Report location clearly and in accordance with any State requirements. *) At surface At proposed prod. zone		11. Sec., T. R. M. or Blk. and Survey or Area
14. Distance in miles and direction from nearest town or post office*		12. County or Parish
		13. State
15. Distance from proposed* location to nearest property or lease line, ft. (Also to nearest drig. unit line, if any)	16. No of acres in lease	17. Spacing Unit dedicated to this well
18. Distance from proposed location* to nearest well, drilling, completed, applied for, on this lease, ft.	19. Proposed Depth	20. BLM/BIA Bond No. in file
21. Elevations (Show whether DF, KDB, RT, GL, etc.)	22. Approximate date work will start*	23. Estimated duration
24. Attachments		

The following, completed in accordance with the requirements of Onshore Oil and Gas Order No. 1, and the Hydraulic Fracturing rule per 43 CFR 3162.3-3 (as applicable)

- |   |   |
|---|---|
| <ul style="list-style-type: none"> <li>1. Well plat certified by a registered surveyor.</li> <li>2. A Drilling Plan.</li> <li>3. A Surface Use Plan (if the location is on National Forest System Lands, the SUPO must be filed with the appropriate Forest Service Office).</li> </ul> | <ul style="list-style-type: none"> <li>4. Bond to cover the operations unless covered by an existing bond on file (see Item 20 above).</li> <li>5. Operator certification.</li> <li>6. Such other site specific information and/or plans as may be requested by the BLM.</li> </ul> |
|---|---|

25. Signature	Name (Printed/Typed)	Date
Title		
Approved by (Signature)	Name (Printed/Typed)	Date
Title		Office

Application approval does not warrant or certify that the applicant holds legal or equitable title to those rights in the subject lease which would entitle the applicant to conduct operations thereon.  
Conditions of approval, if any, are attached.

Title 18 U.S.C. Section 1001 and Title 43 U.S.C. Section 1212, make it a crime for any person knowingly and willfully to make to any department or agency of the United States any false, fictitious or fraudulent statements or representations as to any matter within its jurisdiction.



(Continued on page 2)

\*(Instructions on page 2)

## Additional Operator Remarks

### Location of Well

0. SHL: SWSW / 752 FSL / 21 FWL / TWSP: 23N / RANGE: 7W / SECTION: 33 / LAT: 36.177973 / LONG: -107.588681 ( TVD: 0 feet, MD: 0 feet )

PPP: SESE / 1211 FSL / 149 FEL / TWSP: 23N / RANGE: 7W / SECTION: 32 / LAT: 36.179239 / LONG: -107.589261 ( TVD: 4956 feet, MD: 5108 feet )

PPP: SWSW / 1187 FSL / 1 FWL / TWSP: 23N / RANGE: 7W / SECTION: 33 / LAT: 36.179169 / LONG: -107.573525 ( TVD: 5139 feet, MD: 10030 feet )

BHL: SESE / 441 FSL / 753 FEL / TWSP: 23N / RANGE: 7W / SECTION: 33 / LAT: 36.177062 / LONG: -107.573525 ( TVD: 5139 feet, MD: 10030 feet )

### BLM Point of Contact

Name: CHRISTOPHER P WENMAN

Title: Natural Resource Specialist

Phone: (505) 564-7727

Email: cwenman@blm.gov



- ⊕ FND 2.5" BC  
GLO 1948
- ⊙ FND 2.5" BC  
GLO 1947

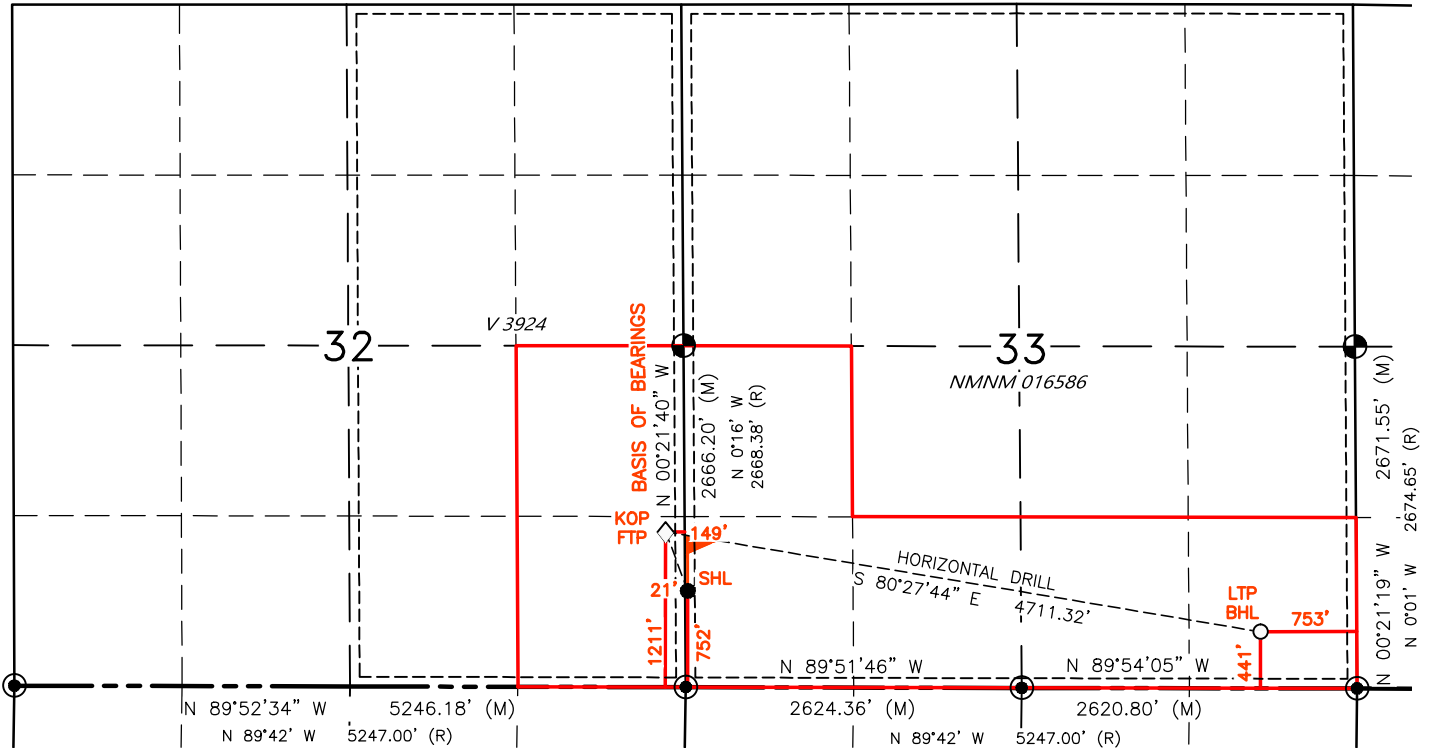

SURFACE LOCATION (SHL) ●  
 752' FSL 21' FWL  
 SEC. 33, T23N, R7W  
 LAT. 36.177973° N (NAD83)  
 LONG. 107.588681° W (NAD83)

FIRST TAKE POINT (FTP) ◇  
 1211' FSL 149' FEL  
 SEC. 32, T23N, R7W  
 LAT. 36.179239° N (NAD83)  
 LONG. 107.589261° W (NAD83)

BOTTOM HOLE LOCATION (BHL) ○  
 441' FSL 753' FEL  
 SEC. 33, T23N, R7W  
 LAT. 36.177062° N (NAD83)  
 LONG. 107.573525° W (NAD83)

KICK OFF POINT (KOP) △  
 1211' FSL 149' FEL  
 SEC. 32, T23N, R7W  
 LAT. 36.179239° N (NAD83)  
 LONG. 107.589261° W (NAD83)

LAST TAKE POINT (LTP) □  
 441' FSL 753' FEL  
 SEC. 33, T23N, R7W  
 LAT. 36.177062° N (NAD83)  
 LONG. 107.573525° W (NAD83)

State of New Mexico  
Energy, Minerals and Natural Resources Department

Submit Electronically  
Via E-permitting

Oil Conservation Division  
1220 South St. Francis Dr.  
Santa Fe, NM 87505

## NATURAL GAS MANAGEMENT PLAN

This Natural Gas Management Plan must be submitted with each Application for Permit to Drill (APD) for a new or recompleted well.

### Section 1 – Plan Description Effective May 25, 2021

**I. Operator:**  DJR Operating, LLC  **OGRID:**  371838  **Date:**  6/9/2025

**II. Type:**  Original  Amendment due to  19.15.27.9.D(6)(a) NMAC  19.15.27.9.D(6)(b) NMAC  Other.

If Other, please describe: \_\_\_\_\_

**III. Well(s):** Provide the following information for each new or recompleted well or set of wells proposed to be drilled or proposed to be recompleted from a single well pad or connected to a central delivery point.

Well Name	ULSTR	Footages	Anticipated Oil BBL/D	Anticipated Gas MCF/D	Anticipated Produced Water BBL/D
N. Alamito Unit 560H	M-33-23N-7W	752 FSL 21 FWL	213	482	85
N. Alamito Unit 562H	M-33-23N-7W	732 FSL 19 FWL	510	1157	204
N. Alamito Unit 563H	M-33-23N-7W	712 FSL 18 FWL	417	945	167
			3-year Decline	3-year Decline	3-year Decline
N. Alamito Unit 560H	M-33-23N-7W	752 FSL 21 FWL	48	192	19
N. Alamito Unit 562H	M-33-23N-7W	732 FSL 19 FWL	115	461	46
N. Alamito Unit 563H	M-33-23N-7W	712 FSL 18 FWL	94	377	38

**IV. Central Delivery Point Name:**  Chaco Processing Plat  [See 19.15.27.9(D)(1) NMAC]

**V. Anticipated Schedule:** Provide the following information for each new or recompleted well or set of wells proposed to be drilled or proposed to be recompleted from a single well pad or connected to a central delivery point.

Well Name	Spud Date	TD Reached Date	Completion Commencement Date	Initial Flow Back Date	First Production Date
N. Alamito Unit 560H	3/26/2026	4/5/2026	5/25/2026	5/26/2026	5/27/2025
N. Alamito Unit 562H	3/27/2026	4/6/2026	5/25/2026	5/26/2026	5/27/2025
N. Alamito Unit 563H	3/28/2026	4/7/2026	5/25/2026	5/26/2026	5/27/2025

**VI. Separation Equipment:**  Attach a complete description of how Operator will size separation equipment to optimize gas capture.

**VII. Operational Practices:**  Attach a complete description of the actions Operator will take to comply with the requirements of Subsection A through F of 19.15.27.8 NMAC.

**VIII. Best Management Practices:**  Attach a complete description of Operator's best management practices to minimize venting during active and planned maintenance.

**Section 2 – Enhanced Plan**

**EFFECTIVE APRIL 1, 2022**

Beginning April 1, 2022, an operator that is not in compliance with its statewide natural gas capture requirement for the applicable reporting area must complete this section.

Operator certifies that it is not required to complete this section because Operator is in compliance with its statewide natural gas capture requirement for the applicable reporting area.

**IX. Anticipated Natural Gas Production:**

Well	API	Anticipated Average Natural Gas Rate MCF/D	Anticipated Volume of Natural Gas for the First Year MCF

**X. Natural Gas Gathering System (NGGS):**

Operator	System	ULSTR of Tie-in	Anticipated Gathering Start Date	Available Maximum Daily Capacity of System Segment Tie-in

**XI. Map.**  Attach an accurate and legible map depicting the location of the well(s), the anticipated pipeline route(s) connecting the production operations to the existing or planned interconnect of the natural gas gathering system(s), and the maximum daily capacity of the segment or portion of the natural gas gathering system(s) to which the well(s) will be connected.

**XII. Line Capacity.** The natural gas gathering system  will  will not have capacity to gather 100% of the anticipated natural gas production volume from the well prior to the date of first production.

**XIII. Line Pressure.** Operator  does  does not anticipate that its existing well(s) connected to the same segment, or portion, of the natural gas gathering system(s) described above will continue to meet anticipated increases in line pressure caused by the new well(s).

Attach Operator’s plan to manage production in response to the increased line pressure.

**XIV. Confidentiality:**  Operator asserts confidentiality pursuant to Section 71-2-8 NMSA 1978 for the information provided in Section 2 as provided in Paragraph (2) of Subsection D of 19.15.27.9 NMAC and attaches a full description of the specific information for which confidentiality is asserted and the basis for such assertion.

### Section 3 - Certifications

Effective May 25, 2021

Operator certifies that, after reasonable inquiry and based on the available information at the time of submittal:

Operator will be able to connect the well(s) to a natural gas gathering system in the general area with sufficient capacity to transport one hundred percent of the anticipated volume of natural gas produced from the well(s) commencing on the date of first production, taking into account the current and anticipated volumes of produced natural gas from other wells connected to the pipeline gathering system; or

Operator will not be able to connect to a natural gas gathering system in the general area with sufficient capacity to transport one hundred percent of the anticipated volume of natural gas produced from the well(s) commencing on the date of first production, taking into account the current and anticipated volumes of produced natural gas from other wells connected to the pipeline gathering system.

***If Operator checks this box, Operator will select one of the following:***

**Well Shut-In.**  Operator will shut-in and not produce the well until it submits the certification required by Paragraph (4) of Subsection D of 19.15.27.9 NMAC; or

**Venting and Flaring Plan.**  Operator has attached a venting and flaring plan that evaluates and selects one or more of the potential alternative beneficial uses for the natural gas until a natural gas gathering system is available, including:

- (a) power generation on lease;
- (b) power generation for grid;
- (c) compression on lease;
- (d) liquids removal on lease;
- (e) reinjection for underground storage;
- (f) reinjection for temporary storage;
- (g) reinjection for enhanced oil recovery;
- (h) fuel cell production; and
- (i) other alternative beneficial uses approved by the division.

### Section 4 - Notices

1. If, at any time after Operator submits this Natural Gas Management Plan and before the well is spud:

(a) Operator becomes aware that the natural gas gathering system it planned to connect the well(s) to has become unavailable or will not have capacity to transport one hundred percent of the production from the well(s), no later than 20 days after becoming aware of such information, Operator shall submit for OCD's approval a new or revised venting and flaring plan containing the information specified in Paragraph (5) of Subsection D of 19.15.27.9 NMAC; or

(b) Operator becomes aware that it has, cumulatively for the year, become out of compliance with its baseline natural gas capture rate or natural gas capture requirement, no later than 20 days after becoming aware of such information, Operator shall submit for OCD's approval a new or revised Natural Gas Management Plan for each well it plans to spud during the next 90 days containing the information specified in Paragraph (2) of Subsection D of 19.15.27.9 NMAC, and shall file an update for each Natural Gas Management Plan until Operator is back in compliance with its baseline natural gas capture rate or natural gas capture requirement.

2. OCD may deny or conditionally approve an APD if Operator does not make a certification, fails to submit an adequate venting and flaring plan which includes alternative beneficial uses for the anticipated volume of natural gas produced, or if OCD determines that Operator will not have adequate natural gas takeaway capacity at the time a well will be spud.

I certify that, after reasonable inquiry, the statements in and attached to this Natural Gas Management Plan are true and correct to the best of my knowledge and acknowledge that a false statement may be subject to civil and criminal penalties under the Oil and Gas Act.

Signature: <i>Shaw-Marie Valadez</i>
Printed Name: Shaw-Marie Ford
Title: Regulatory Specialist
E-mail Address: <a href="mailto:sford@enduringresources.com">sford@enduringresources.com</a>
Date: 9/24/2025
Phone: 505-716-3297
<b>OIL CONSERVATION DIVISION</b> <b>(Only applicable when submitted as a standalone form)</b>
Approved By:
Title:
Approval Date:
Conditions of Approval:



DJR OPERATING, LLC.  
OGRID NO: 371838  
NATURAL GAS MANAGEMENT PLAN  
N. ALAMITO UNIT 560H 562H 563H

### SEPARATION EQUIPMENT

DJR Operating, LLC (DJR) has pulled representative pressurized samples from wells in the same producing formation. DJR has utilized these samples in process simulations to determine the amount of gas anticipated in each stage of the process and utilized this information with a safety factor to size the equipment listed below:

Separation equipment will be set as follows:

- Individual 3 phase separator will be set for the individual well.
- The separator will be sized based on the anticipated volume of the well and the pressure of the lines utilized for oil, gas, and water takeaway.
- The 3 phase production separator will be equipped with a 0.75 MMBtu/hr indirect fired heater.

Heater treaters will be set as follows:

- Individual heater treaters will be set for the individual well.
- The heater treaters are sized based on the anticipated combined volume of oil and produced water predicted to come from the initial 3 phase separator.
- Oil will be separated from the produced water and the oil/produced water will be sent to its respective tanks.
- The combined oil and natural gas stream is routed to the Vapor Recovery Tower.

Vapor Recovery Equipment will be set as follows:

- The Vapor Recovery Tower has been sized, based on the anticipated volume of gas from the heater treater and oil and water tanks.
- The Vapor Recovery Unit has been sized, based on the anticipated volume of gas from the heater treater and oil and water tanks. The Vapor Recovery Unit is utilized to push the recovered gas into the sales pipeline.

Production storage tanks will be set as follows:

- The oil and produced water tanks utilize a closed vent capture system to ensure all breathing, working, and flashing losses are routed to the Vapor Recovery Tower and Vapor Recovery Unit.
- Each of the production storage tanks will be equipped with a 0.5 MMBtu/hr indirect heater.



DJR OPERATING, LLC.  
OGRID NO: 371838  
NATURAL GAS MANAGEMENT PLAN  
N. ALAMITO UNIT 560H 562H 563H

### **VENTING and FLARING**

DJR Operating, LLC (DJR) has a natural gas system available prior to startup of completion operations. DJR utilizes a Vapor Recovery Unit System and sells all natural gas except during periods of startup, shutdown, maintenance, or malfunction for the gas capturing equipment, including the vapor recovery tower, vapor recovery unit, storage tanks, and pipelines.

Currently, DJR utilizes the following from list A-I of Section 3 for its operations to minimize flaring:

- a) DJR utilizes natural gas-powered generators to power its leases where grid power isn't available.
- b) When electrical grid power is unavailable, natural gas generators will be used for major equipment onsite.
- c) DJR's in service compression will be natural gas powered.
- d) Should liquids removal, such as dehydration be required, units will be powered by natural gas.

DJR will only flare gas during the following times:

- o Scheduled maintenance for gas capturing equipment including:
  - o Vapor Recovery Tower
  - o Vapor Recovery Unit
  - o Storage tanks
  - o Pipelines
  - o Emergency flaring



DJR OPERATING, LLC.  
OGRID NO: 371838  
NATURAL GAS MANAGEMENT PLAN  
N. ALAMITO UNIT 560H 562H 563H

## OPERATIONAL PRACTICES

### 19.15.27.8 A. Venting and Flaring of Natural Gas

DJR Operating, LLC (DJR) understands the requirements of NMAC 19.15.27.8 which states that the venting and flaring of natural gas during drilling, completion or production that constitutes waste as defined in 19.15.2 are prohibited.

### 19.15.27.8 B. Venting and flaring during drilling operations

- DJR shall capture or combust natural gas if technically feasible during drilling operations using best industry practices.
- A flare stack with a 100% capacity for expected volumes will be set on location of the facility at least 100 feet from the nearest surface hole location, well heads, and storage tanks.
- In the event of an emergency, DJR will vent natural gas in order to avoid substantial impact. DJR shall report the vented or flared gas to the NMOCD.

### 19.15.27.8 E. Venting and flaring during completion or recompletion operations

During Completion Operations, DJR utilizes the following:

- DJR facilities are built and ready from day 1 of Flowback.
- Individual well test separators will be set to properly separate gas and liquids. Temporary test separator will be utilized initially to process volumes. In addition, separators will be tied into flowback tanks which will be tied into the gas processing equipment for sales down a pipeline. See Separation Equipment for details.
- Should the facility not yet be capable of processing gas, or the gas does not meet quality standards, then storage tanks will be set that are tied into gas busters or temporary flare to manage natural gas. This flare would meet the following requirements:
  - 1) An appropriately sized flare stack with an automatic igniter.
  - 2) DJR analyzes the natural gas samples twice per week.
  - 3) DJR routes the natural gas into a gathering pipeline as soon as the pipeline specifications are met.
  - 4) DJR provides the NMOCD with pipeline specifications and natural gas data.



#### **19.15.27.8 D. Venting and flaring during production operations**

During Production Operations DJR will not vent or flare natural gas except under the following circumstances:

1. During an emergency or malfunction
2. To unload or clean-up liquid holdup in a well to atmospheric pressure, provided:
  - a. DJR does not vent after the well achieves a stabilized rate and pressure.
  - b. DJR will remain present on-site during liquids unloading by manual purging and take all reasonable actions to achieve a stabilized rate and pressure at the earliest practical time.
  - c. DJR will optimize the system to minimize natural gas venting on any well equipped with a plunger lift or auto control system.
  - d. Best Management Practices will be used during downhole well maintenance.
3. During the first year of production from an exploratory well provided:
  - a. DJR receives approval from the NMOCD.
  - b. DJR remains in compliance with the NM gas capture requirements.
  - c. DJR submits an updated C-129 form to the NMOCD.
4. During the following activities unless prohibited:
  - a. Gauging or sampling a storage tank or low-pressure production vessel.
  - b. Loading out liquids from a storage tank.
  - c. Repair and maintenance.
  - d. Normal operation of gas activated pneumatic controller or pump.
  - e. Normal operation of a storage tank but not including venting from a thief hatch.
  - f. Normal operation of dehydration units.
  - g. Normal operations of compressors, compressor engines, turbines, valves, flanges, and connectors.
  - h. During a bradenhead, packer leakage test, or production test lasting less than 24-hours.
  - i. When natural gas does not meet the gathering pipeline specifications.
  - j. Commissioning of pipelines, equipment, or facilities only for as long as necessary to purge introduced impurities.

#### **19.15.27.8 E. Performance standards**

1. DJR has utilized process simulations with a safety factor to design all separation and storage equipment. The equipment is routed to a Vapor Recovery System and utilizes a flare as back up for periods of startup, shutdown, maintenance, or malfunction of the VRU System.
2. DJR will install a flare that designed to handle the full volume of vapors from the facility in case of the VRU failure and it its designed with an auto ignition system.
3. Flare stacks will appropriately sized and designed to ensure proper combustion efficiency.
  - a. Flare stacks installed or replaced will be equipped with an automatic ignitor or continuous pilot.



- b. Previously installed flare stacks will be retrofitted with an automatic ignitor, continuous pilot, or technology that alerts DJR of flare malfunction within 18 months after May 25, 2021.
  - c. Flare stacks replaced after May 25, 2021, will be equipped with an automatic ignitor or continuous pilot if located at a well or facility with average daily production of 60,000 cubic feet of natural gas or less.
  - d. Flare stacks will be located at least 100 feet from the well and storage tanks and securely anchored.
4. DJR will conduct an AVO inspection on all components for leaks and defects on a weekly basis.
  5. DJR will make and keep records of AVO inspections which will be available to the NMOCD for at least 5 years.
  6. DJR may use a remote or automated monitoring technology to detect leaks and releases in lieu of AVO inspections with prior NMOCD approval.
  7. Facilities will be designed to minimize waste.
  8. DJR will resolve emergencies as promptly as possible.

**19.15.27.8 F. Measurement or estimation of vented and flared natural gas**

1. DJR will have meters on both the low- and high-pressure sides of the flares and the volumes will be recorded in DJR's SCADA system.
2. DJR will install equipment to measure the volume of flared natural gas that has an average daily production of 60,000 cubic feet or greater of natural gas.
3. DJR's measuring equipment will conform to the industry standards.
4. The measurement system is designed such that it cannot be bypassed except for inspections and servicing meters.
5. DJR will estimate the volume of vented or flared natural gas using a methodology that can be independently verified if metering is not practicable due to low flow rate or pressure.
6. DJR will estimate the volume of flared and vented natural gas based on the results of an annual GOR test for wells that do not require measuring equipment reported on Form C-116.
7. DJR will install measuring equipment whenever the NMOCD determines that metering is necessary.



DJR OPERATING, LLC.  
OGRID NO: 371838  
NATURAL GAS MANAGEMENT PLAN  
N. ALAMITO UNIT 560H 562H 563H

**BEST MANAGEMENT PRACTICES**

DJR Operating, LLC (DJR) utilizes the following Best Management Practices to minimize venting during active and planned maintenance.

DJR has a closed vent capture system to route emissions from the heater treater, tanks, and vapor recovery to the vapor recovery unit with an enclosed combustion device (ECD) for backup. The system is designed such that if the vapor recovery unit is taken out of service for any reason, the vapors will be routed to the ECD for combustion.

DJR will isolate and attempt to route all vapors to the vapor recovery unit or ECD prior to opening any lines for maintenance to minimize venting from the equipment.

DJR shall notify the NMOCD of venting or flaring that exceeds 50 MCF but less than 500 MCF in volume that either resulted from an emergency or malfunction, or an event lasting over eight hours or more cumulatively within any 24-hour period from a single event by filing a form C-129 no later than 15 days following the discovery or commencement of venting or flaring.

DJR shall notify the NMOCD verbally or by e-mail within 24-hours following discovery or commencement of venting or flaring that exceeds 500 MCF in volume or otherwise qualifies as a major release as defined in 19.15.29.7 NMAC from a single event and provide the information required in form C-129 to the NMOCD no later than 15 days that verifies, updates, or corrects the verbal or e-mail notification.

DJR will install measuring equipment to conform to industry standards such as American Petroleum Institute (API) Manual of Petroleum Measurement Standards (MPMS) Chapter 14.10 Measurement of Flow to Flares.

DJR's measuring equipment shall not be designed or equipped with a manifold that allows the diversion of natural gas around the metering element except for the sole purpose of inspecting and servicing the measurement equipment.

DJR shall report the volume of vented and flared natural gas for each well or facility at which venting or flaring occurred on a monthly basis.



**ENDURING RESOURCES IV, LLC**  
**6300 S SYRACUSE WAY, SUITE 525**  
**CENTENNIAL, COLORADO 80211**

**DRILLING PLAN:** *Drill, complete, and equip single lateral in the Mancos-Gallup formation*

**WELL INFORMATION:**

**Name:** North Alamito Unit 560H

**API Number:** Not yet assigned

**AFE Number:** Not yet assigned

**ER Well Number:** Not yet assigned

**State:** New Mexico

**County:** Sandoval

**Surface Elevation:** 6,876 ft ASL (GL) 6,900 ft ASL (KB)  
**Surface Location:** 33-23-7 Sec-Twn-Rng 752 ft FSL 21 ft FWL  
 36.177973 ° N latitude 107.588681 ° W longitude (NAD 83)  
**BH Location:** 33-23-7 Sec-Twn-Rng 441 ft FSL 753 ft FEL  
 36.177062 ° N latitude 107.573525 ° W longitude (NAD 83)

**Driving Directions:** FROM THE INTERSECTION OF US HWY 550 & US HWY 64 IN BLOOMFIELD, NM:

South on US Hwy 550 for 39.0 miles to MM 112.7, Right (South) on CR #7900 / IR #7061 for 5.1 miles to T, Left (East) leaving CR #7900 onto Lybrook Rd 5.1 miles to lease road; Right (South) for 300 ft to NAU 328H pad entrance. There is one existing well on this location and 3 proposed wells. From North (location entrance) to South: NAU 560H, NAU 562H, and NAU 563H. The NAU 328H (existing well) is ±80' to the SouthWest of the proposed wells.

**GEOLOGIC AND RESERVOIR INFORMATION:**

<b>Prognosis:</b>	<b>Formation Tops</b>	<b>TVD (ft ASL)</b>	<b>TVD (ft KB)</b>	<b>MD (ft KB)</b>	<b>O / G / W</b>	<b>Pressure</b>
	Ojo Alamo	6,020	880	880	W	normal
	Kirtland	5,980	920	920	W	normal
	Fruitland	5,790	1,110	1,110	G, W	sub
	Pictured Cliffs	5,480	1,420	1,423	G, W	sub
	Lewis	5,321	1,579	1,588	G, W	normal
	Chacra	5,081	1,819	1,836	G, W	normal
	Cliff House	4,009	2,891	2,946	G, W	sub
	Menefee	3,979	2,921	2,977	G, W	normal
	Point Lookout	3,086	3,814	3,902	G, W	normal
	Mancos	2,881	4,019	4,111	O,G	sub (~0.38)
	Gallup (MNCS_A)	2,571	4,329	4,422	O,G	sub (~0.38)
	MNCS_B	2,466	4,434	4,527	O,G	sub (~0.38)
	MNCS_C	2,376	4,524	4,617	O,G	sub (~0.38)
	MNCS_Cms	2,336	4,564	4,657	O,G	sub (~0.38)
	MNCS_D	2,206	4,694	4,790	O,G	sub (~0.38)
	MNCS_E	2,075	4,825	4,935	O,G	sub (~0.38)
	MNCS_F	2,015	4,885	5,009	O,G	sub (~0.38)
	MNCS_G	1,944	4,956	5,108	O,G	sub (~0.38)
	MNCS_H	1,883	5,017	5,214	O,G	sub (~0.38)
	MNCS_I	1,827	5,073	5,360	O,G	sub (~0.38)
	<b>FTP TARGET</b>	<b>1,944</b>	<b>4,956</b>	<b>5,108</b>	<b>O,G</b>	<b>sub (~0.38)</b>

<b>PROJECTED TD</b>	<b>1,761</b>	<b>5,139</b>	<b>10,030</b>	<b>O,G</b>	<b>sub (~0.38)</b>
---------------------	--------------	--------------	---------------	------------	--------------------

**Surface:** Nacimiento

**Oil & Gas Zones:** Several gas bearing zones will be encountered; target formation is the Gallup

**Pressure:** Normal (0.43 psi/ft) or sub-normal pressure gradients anticipated in all formations

Max. pressure gradient: 0.43 psi/ft Evacuated hole gradient: 0.22 psi/ft

**Maximum anticipated BH pressure, assuming maximum pressure gradient: 2,210 psi**

**Maximum anticipated surface pressure, assuming partially evacuated hole: 1,080 psi**

**Temperature:** Maximum anticipated BHT is 125° F or less

**H<sub>2</sub>S INFORMATION:**

**H<sub>2</sub>S Zones:** Encountering hydrogen-sulfide bearing zones is **NOT** anticipated.

**Safety:** Sensors and alarms will be placed in the substructure, on the rig floor, above the pits, and at the shakers.

**LOGGING, CORING, AND TESTING:**

**Mud Logs:** None planned; remote geo-steering from drill out of 7" casing to TD; gas detection from drillout of 9-5/8" casing to TD.

**MWD / LWD:** Gamma Ray from drillout of 9-5/8" casing to TD

**Open Hole Logs:** None planned

**Testing:** None planned

**Coring:** None planned

**Cased Hole Logs:** CBL on 7" casing from deepest free-fall depth to surface

**DRILLING RIG INFORMATION:**

**Contractor:** Ensign

**Rig No.:** 140

**Draw Works:** Pacific Rim 1500AC (1,500 hp)

**Mast:** Process MFG Corp Swing Up Triple (136 ft, 750,000 lbs)

**Top Drive:** Tesco 400-EXI-600 (400 ton)

**Prime Movers:** 3 - CAT 3512C (1,350 hp)

**Pumps:** 2 - Gardner Denver PZ-11 (7,500 psi)

**BOPE 1:** T3 Annular & Shaffer double gate ram (11", 5,000 psi)

**BOPE 2:** T3 annular(11", 5,000 psi)

**Choke** 3", 5,000 psi

**KB-GL (ft):** 23.5

**Note:** Actual drilling rig may vary depending on availability at time the well is scheduled to be drilled.

**BOPE REQUIREMENTS:**

*See attached diagram for details regarding BOPE specifications and configuration.*

- 1) Rig will be equipped with upper and lower kelly cocks with handles available.
- 2) Inside BOP and TIW valves will be available to use on all sizes and threads of drill pipe used while drilling the well.
- 3) BOP accumulator will have enough capacity to open the HCR valve, close all rams and annular preventer, and retain minimum of 200 psi above precharge on the closing manifold without the use of closing pumps. The fluid reservoir capacity shall be at least double the usable fluid volume of the accumulator system capacity, and the fluid level shall be maintained at manufacturer's recommendation. There will be two additional sources of power for the closing pumps (electric and air). Sufficient nitrogen bottles will be available and will be recharged when pressure falls below manufacturer's recommended minimum.

- 4) BOP testing shall be conducted (a) when initially installed, (b) whenever any seal is broken or repaired, (c) if the time since the previous test exceeds 30 days. Tests will be conducted using a test plug. BOP ram preventers will be tested to 3,000 psig for 10 minutes, and the annular preventer will be tested to 1,500 psi for 10 minutes. Ram and annular preventers will be tested to 250 psi for 5 minutes. Additionally, BOP and casing strings will be tested to .22 psi/ft or 1,500 psi, whichever is greater but not exceeding 70% of yield strength of the casing, for 30 minutes, prior to drilling out 13-3/8" and 9-5/8" casing. Rams and hydraulically operated remote choke line valve will be function tested daily at a minimum.
- 5) Remote valve for BOP rams, HCR, and choke shall be placed in a location that is readily available to the driller. The remote BOP valve shall be capable of closing and opening the rams.
- 6) Manual locking devices (hand wheels) shall be intalled on rams. A valve will be installed on the annular preventer's closing line as close as possible to the preventer to act as a locking device. The valve will be maintained in the open position and shall only be closed when there is no power to the accumulator.

**FLUIDS AND SOLIDS CONTROL PROGRAM:**

**Fluid Measurement:**

Pumps shall be equipped with stroke counters with displays in the dog-house. Slow pump speed shall be recorded daily and after mudding up, at a minimum, on the drilling report. A Pit Volume Totalizer will be installed and the readout will be displayed in the dog-house. Gas-detecting equipment will be installed at the shakers, and readouts will be available in the dog-house and the in the geologist's work-station (if geologist or mud-logger is on-site).

**Closed-Loop System:** A fully, closed-loop system will be utilized. The system will consist of above-ground piping and above-ground storage tanks and bins. The system will not entail any earthen pits, below-grade storage, or drying pads. All equipment will be disassembled and removed from the site when drilling operations cease. The system will be capable of storing all fluids and generated cuttings and of preventing uncontrolled releases of the same. The system will be operated in an efficient manner to allow the recycling and reuse of as much fluid as possible and to minimize the amount of fluids and solids that require disposal.

**Fluid Disposal:** Fluids that cannot be reused, recycled, or returned to the supplier will be hauled to and disposed of at an approved disposal site (Industrial Ecosystem, Inc. or Envirotech, Inc.).

**Solids Disposal:** Drilling solids will be stored (until haul-off) on-site in separate containers with no other waste, debris, or garbage products. Waste solids will be hauled to and disposed of at an approved disposal site (Industrial Ecosystem, Inc. or Envirotech, Inc.).

**Fluid Program:** See "Detailed Drilling Plan" section and attached Newpark mud program for additional details.

**DETAILED DRILLING PLAN:**

**SURFACE:** *Drill vertically to casing setting depth (plus necessary rathole), run casing, cement casing to surface.*

0 ft (MD)	to	350 ft (MD)	Hole Section Length:	350 ft
0 ft (TVD)	to	350 ft (TVD)	Casing Required:	350 ft

**Note:** *Surface hole may be drilled, cased, and cemented with a smaller rig in advance of the drilling rig.*

Fluid:	Type	MW (ppg)	FL (mL/30 min)	PV (cp)	YP (lb/100 sqft)	pH	Comments
	Fresh Water	8.4	N/C	2 - 8	2 - 12	9.0	Spud mud

**Hole Size:** 12-1/4"

**Bit / Motor:** Mill Tooth or PDC, no motor

**MWD / Survey:** No MWD, deviation survey

**Logging:** None

Casing Specs:	Wt (lb/ft)	Grade	Conn.	Collapse (psi)	Burst (psi)	Tens. Body (lbs)	Tens. Conn (lbs)
Specs	9.625	36.0	J-55	LTC	2,020	3,520	564,000
						423,000	

Loading		153	1,089	110,988	110,988
Min. S.F.		13.21	3.23	5.08	3.81

Assumptions: Collapse: fully evacuated casing with 8.4 ppg equivalent external pressure gradient  
 Burst: maximum anticipated surface pressure with 9.5 ppg fluid inside casing while drilling intermediate hole and 8.4 ppg equivalent external pressure gradient  
 Tension: buoyed weight in 8.4 ppg fluid with 100,000 lbs over-pull

MU Torque (ft lbs): Minimum: 3,400 Optimum: 4,530 Maximum: 5,660

Casing Summary: Float shoe, 1 jt casing, float collar, casing to surface

Centralizers: 2 centralizers per jt stop-banded 10' from each collar on bottom 3 jts, 1 centralizer per 2 jts to surface

Cement:	Type	Weight (ppg)	Yield (cuft/sk)	Water (gal/sk)	Hole Cap. (cuft/ft)	% Excess	Planned TOC (ft MD)	Total Cmt (sx)	Total Cmt (cu ft)
Redi-Mix	TYPE I-II	14.5	1.61	7.41	0.3132	50%	0	114	184

Calculated cement volumes assume gauge hole and the excess noted in table Csg ID 8.921  
 Mesa Ready Mix or first available Shoe Track L 44

Notify NMOCD & BLM if cement is not circulated to surface. Cement must achieve 500 psi compressive strength before drilling out.

INTERMEDIATE: Drill as per directional plan to casing setting depth, run casing, cement casing to surface.

350 ft (MD)	to	5,464 ft (MD)	Hole Section Length:	5,114 ft
350 ft (TVD)	to	5,091 ft (TVD)	Casing Required:	5,464 ft

Fluid:	Type	MW (ppg)	FL (mL/30 min)	PV (cp)	YP (lb/100 sqft)	pH	Comments
	LSND (KCI)	8.8 - 9.2	15	8 - 14	6 - 12	10.8 - 11.2	No OBM

Hole Size (inches): 8.75

Bit / Motor: 8-3/4" PDC bit w/mud motor

MWD / Survey: MWD Survey with inclination and azimuth survey (every 100' at a minimum), GR optional

Logging: None

Pressure Test: NU BOPE and test (as noted above); pressure test 9-5/8" casing to 1,500 psi for 30 minutes.

Casing Specs:	Wt (lb/ft)	Grade	Conn.	Collapse (psi)	Burst (psi)	Tens. Body (lbs)	Tens. Conn (lbs)	
Specs	7	26.0	J-55	BTC	4,320	4,980	415,000	490,000
Loading					2,224	1,371	223,887	223,887
Min. S.F.					1.94	3.63	1.85	2.19

Assumptions: Collapse: fully evacuated casing with 8.4 ppg equivalent external pressure gradient  
 Burst: maximum anticipated surface pressure with 9.5 ppg fluid inside casing while drilling production hole and 8.4 ppg equivalent external pressure gradient  
 Tension: buoyed weight in 8.4 ppg fluid with 100,000 lbs over-pull

MU Torque (ft lbs): Minimum: NA Optimum: NA Maximum: NA

Centralizers: 1 per joint in non-vertical hole; 1 per 3-joints in vertical hole

Cement:	Type	Weight (ppg)	Yield (cuft/sk)	Water (gal/sk)	% Excess	Planned TOC (ft MD)	Total Cmt (sx)	Total Cmt (cu ft)
Lead	III:POZ Blend	12.5	2.150	12.06	100%	0	539	1,159
Tail	Type III	13.5	1.710	8.88	30%	4,011	172	293

Annular Capacity	0.16681	cuft/ft	7" casing x 9-5/8" casing annulus				Shoe Track L	44
	0.1503	cuft/ft	7" casing x 8-3/4" hole annulus				Casing ID	6.276
	0.2148	cuft/ft	7" casing casing volume				Est displacement bbls	207.4

Calculated cement volumes assume gauge hole and the excess noted in table

		10 bbls D-Mud Breaker (SAPP)							
<b>Spacer</b>	10 bbls water f/b	f/b	10 bbls water f/b	D-MPA-2 .4%					
		D-CSE 1 5.0%	BWOC Fluid Loss & Control	D-SA 1 1.4%					
<b>Lead</b>	ASTM Type III 90/10 Poz	BWOC Strength Enhancer	Gas Migration Control	BWOC Na Metasilicate	D-CD 2 .4%	Cello Face LCM .25 lb/sx	D-FP 1 .5%	D-R1 0.8%	BWOC Defoamer Retarder
		D-CSE 1 5.0%	BWOC Fluid Loss & Control						
<b>Tail</b>	ASTM Type III 90/10 Poz	BWOC Strength Enhancer	Gas Migration Control	Cello Face LCM .25 lb/sx	D-FP 1 .5%	D-R1 0.1%			

**Drake Intermediate Cementing Program**

**Notify NMOCD & BLM if cement is not circulated to surface. Cement must achieve 500 psi compressive strength before drilling out.**

**PRODUCTION: Drill to TD following directional plan, run casing, cement casing to surface.**

<b>5,464</b>	<b>ft (MD)</b>	<b>to</b>	<b>10,030</b>	<b>ft (MD)</b>	<b>Hole Section Length:</b>	<b>4,566</b>	<b>ft</b>
<b>5,091</b>	<b>ft (TVD)</b>	<b>to</b>	<b>5,139</b>	<b>ft (TVD)</b>	<b>Casing Required:</b>	<b>4,716</b>	<b>ft</b>
	<b>Estimated KOP:</b>		<b>4,614</b>	<b>ft (MD)</b>	<b>4,521</b>	<b>ft (TVD)</b>	
	<b>Estimated Liner Top:</b>		<b>5,314</b>	<b>ft (MD)</b>	<b>5,059</b>	<b>ft (TVD)</b>	
	<b>Estimated Landing Point (FTP):</b>		<b>5,108</b>	<b>ft (MD)</b>	<b>4,956</b>	<b>ft (TVD)</b>	
	<b>Estimated Lateral Length:</b>		<b>4,922</b>	<b>ft (MD)</b>			

<b>Fluid:</b>	<b>Type</b>	<b>MW (ppg)</b>	<b>FL (mL/30')</b>	<b>PV (cp)</b>	<b>YP (lb/100 sqft)</b>	<b>pH</b>	<b>Comments</b>	<b>Comments</b>
	<b>WBM</b>	8.7 - 9.0	NC	+20	±2	8.5-9.5	prod water	OBM as contingency

**Hole Size:** 6.125

**Bit / Motor:** 6-1/8" PDC bit w/mud motor

**MWD / Survey:** MWD with GR, inclination, and azimuth (survey every joint from KOP to Landing Point and survey every 100' minimum before KOP and after Landing Point)

**Logging:** GR MWD for entire section, no mud-log or cuttings sampling, no OH WL logs

**Pressure Test:** NU BOPE and test (as noted above); pressure test 9-5/8" casing to **1,500** psi for 30 minutes.

<b>Liner/Casing Specs:</b>	<b>Size (in)</b>	<b>Wt (lb/ft)</b>	<b>Grade</b>	<b>Conn.</b>	<b>Collapse (psi)</b>	<b>Burst (psi)</b>	<b>Tens. Body (lbs)</b>	<b>Tens. Conn (lbs)</b>
<b>Specs</b>	4.500	11.6	P-110	BTC	7,560	10,690	367,000	385,000
<b>Loading</b>					2,539	8,794	200,398	200,398
<b>Min. S.F.</b>					<b>2.98</b>	<b>1.22</b>	<b>1.83</b>	<b>1.92</b>

**Assumptions:** Collapse: fully evacuated casing with 9.5 ppg fluid in the annulus (floating casing during running)

Burst: 8,500 psi maximum surface treating pressure with 10.2 ppg equivalent mud weight sand laden fluid with 8.4 ppg equivalent external pressure gradient.

Tension: buoyed weight in 9.0 ppg fluid with 100,000 lbs over-pull. Tension calculations assume vertical hole to approximate drag in lateral.

**MU Torque (ft lbs):** Minimum: BTC Optimum: BTC Maximum: BTC

**Centralizers:** Centralizer count and placement may be adjusted based on well conditions and as-drilled surveys.

<b>Cement:</b>	<b>Type</b>	<b>Weight (ppg)</b>	<b>Yield (cuft/sk)</b>	<b>Water (gal/sk)</b>	<b>% Excess</b>	<b>Planned TOC (ft MD)</b>	<b>Total Cmt (sx)</b>	<b>Total Cmt (cu ft)</b>
<b>Spacer</b>	Water	8.4				0	10 bbls	
<b>Spacer</b>	IntegraGuard Star	10		35.7		0	20 bbls	
<b>Tail</b>	G:POZ blend	13.3	1.520	7.50	35%	5,314	395	600
<b>Displacement</b>		127	est bbls					

**Annular Capacities** 0.1044 cuft/ft 4-1/2" casing x 7" casing annulus

0.09417 cuft/ft 4-1/2" casing x 6-1/8" hole annulus  
 0.0873 cuft/ft 4-1/2" casing volume est shoe jt ft 42  
 0.0102 bbls/ft 4" DP capacity

Calculated cement volumes assume gauge hole and the excess noted in table  
 American Cementing Liner & Production Blend

<b>Spacer</b>	S-8 Silica Flour 113.2 lbs/bbl	Avis 616 viscosifier 4.0 lb/bbl	Xcem-311 Defoamer .8 lb/bbl	SS201 Surfactant 0.5 gal/bbl			
<b>Lead/Tail</b>	Type G 50%	Pozzolan Fly Ash Extender 50%	Bentonite Viscosifier 4% BWOB	FL24 Fluid Loss .4% BWOB	IntegraGuard GW86 Viscosifier .1% BWOB	R3 Retarder BWOB	Xcem-311 Defoamer 0.3% BWOB

**Notify NMOCD & BLM if cement is not circulated to surface.**

**Note:** This well will not be considered an unorthodox well location as defined by NMAC 19.15.16.15.C.5. As defined in NMAC 19.15.16.15.C.1.a and 19.15.16.15.C.1.b, no point in the completed interval shall be closer to the unit boundary than 100' measured along the azimuth of the well or 330' measured perpendicular to the azimuth well. The boundaries of the completed interval, as defined by NMAC 19.15.16.7.B, are the last take point and first take point, as defined by NMAC 19.15.16.7.E and NMAC 19.15.16.7.J, respectively. In the case of this well, the last take point will be the bottom toe-initiation sleeve, and the first take point will be the top perforation. **Neither the toe-initiation sleeve nor the top perforation shall be closer to the unit boundary than 100' measured along the azimuth of the well or 330' measured perpendicular to the azimuth of the well.**

**FINISH WELL: ND BOP, cap well, RDMO.**

**COMPLETION AND PRODUCTION PLAN:**

**Est Lateral Length:** 4,822  
**Est Frac Inform:** 20 Frac Stages 78,000 bbls slick water 6,270,000 lbs proppant  
**Flowback:** Flow back through production tubing as pressures allow  
**Production:** Produce through production tubing via gas-lift into permanent production and storage facilities

**ESTIMATED START DATES:**

**Drilling:** 3/26/2026  
**Completion:** 5/25/2026  
**Production:** 7/9/2026

**Prepared by:** Greg Olson 7/18/2024  
**Updated:** Greg Olson 4/3/2025  
 Greg Olson 9/22/2025

**WELL NAME: North Alamito Unit 560H**

**OBJECTIVE: Drill, complete, and equip single lateral in the Mancos-Gallup formation**

**API Number:** Not yet assigned

**AFE Number:** Not yet assigned

**ER Well Number:** Not yet assigned

**State:** New Mexico

**County:** Sandoval

**Surface Elev.:** 6,876 ft ASL (GL) 6,900 ft ASL (KB)

**Surface Location:** 33-23-7 Sec-Twn- Rng 752 ft FSL 21 ft FWL

**BH Location:** 33-23-7 Sec-Twn- Rng 441 ft FSL 753 ft FEL

**Driving Directions:** FROM THE INTERSECTION OF US HWY 550 & US HWY 64 IN BLOOMFIELD, NM:

South on US Hwy 550 for 39.0 miles to MM 112.7, Right (South) on CR #7900 / IR #7061 for 5.1 miles to T, Left (East) leaving CR #7900 onto Lybrook Rd 5.1 miles to lease road; Right (South) for 300 ft to NAU 328H pad entrance. There is one existing well on this location and 3 proposed wells. From North (location entrance) to South: NAU 560H, NAU 562H, and NAU 563H. The NAU 328H (existing well) is ±80' to the SouthWest of the proposed wells.

QUICK REFERENCE	
Sur TD (MD)	350 ft
Int TD (MD)	5,464 ft
KOP (MD)	4,614 ft
KOP (TVD)	4,521 ft
Target (TVD)	4,956 ft
Curve BUR	10 °/100 ft
POE (MD)	5,108 ft
TD (MD)	10,030 ft
Lat Len (ft)	4,922 ft

**WELL CONSTRUCTION SUMMARY:**

	Hole (in)	TD MD (ft)	Csg (in)	Csg (lb/ft)	Csg (grade)	Csg (conn)	Csg Top (ft)	Csg Bot (ft)
Surface	12.250	350	9.625	36	J-55	LTC	0	350
Intermediate	8.750	5,464	7	26.0	J-55	BTC	0	5,464
Production	6.125	10,030	4.500	11.6	P-110	BTC	5,314	10,030

**CEMENT PROPERTIES SUMMARY:**

	Type	Wt (ppg)	Yd (cuft/sk)	Wtr (gal/sk)	Hole Cap. (cuft/ft)	% Excess	TOC (ft MD)	Total (sx)
Surface	TYPE I-II	14.5	1.61	7.41	0.3132	50%	0	114
Inter. (Lead)	III:POZ Blend	12.5	2.15	12.06	0.1668	100%	0	539
Inter. (Tail)	Type III	13.5	1.71	8.88	0.1503	30%	4,011	172
Prod. (Lead)	TegraGuard S	10	0.000	35.7	0.1044	0%	0	20 bbls
Prod. (Tail)	G:POZ blend	13.3	1.520	7.5	0.0873	35%	5,314	395

**COMPLETION / PRODUCTION SUMMARY:**

**Frac:** 20 Frac Stages, 78000 bbls slick water, 6270000 lbs proppant

**Flowback:** Flow back through production tubing as pressures allow

**Production:** Produce through production tubing via gas-lift into permanent production and storage facilities

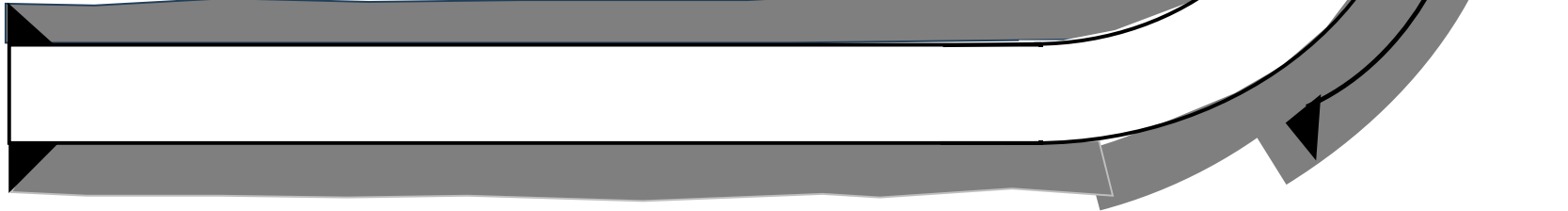

Tops	TVD (ft KB)	MD (ft KB)
Ojo Alamo	880	880
Kirtland	920	920
Fruitland	1,110	1,110
Pictured Cliffs	1,420	1,423
Lewis	1,579	1,588
Chacra	1,819	1,836
Cliff House	2,891	2,946
Menefee	2,921	2,977
Point Lookout	3,814	3,902
Mancos	4,019	4,111
Gallup (MNCS_A)	4,329	4,422
MNCS_B	4,434	4,527
MNCS_C	4,524	4,617
MNCS_Cms	4,564	4,657
MNCS_D	4,694	4,790
MNCS_E	4,825	4,935
MNCS_F	4,885	5,009
MNCS_G	4,956	5,108
MNCS_H	5,017	5,214
MNCS_I	5,073	5,360
FTP TARGET	4,956	5,108
PROJECTED TD	5,139	10,030

### CHOKE MANIFOLD DIAGRAM

NOTE: EXACT BOPE AND CHOKE CONFIGURATION AND COMPONENTS MAY DIFFER FROM WHAT IS DEPICTED IN THE DIGRAMS BELOW DEPENDING ON THE RIG AND ITS ASSOCIATED EQUIPMENT. RAM PREVENTERS, ANNULAR PREVENTERS, AND CHOKE MANIFOLD AND COMPONENTS WILL BE RATED TO 3,000 PSI MINIMUM.

### CHOKE MANIFOLD

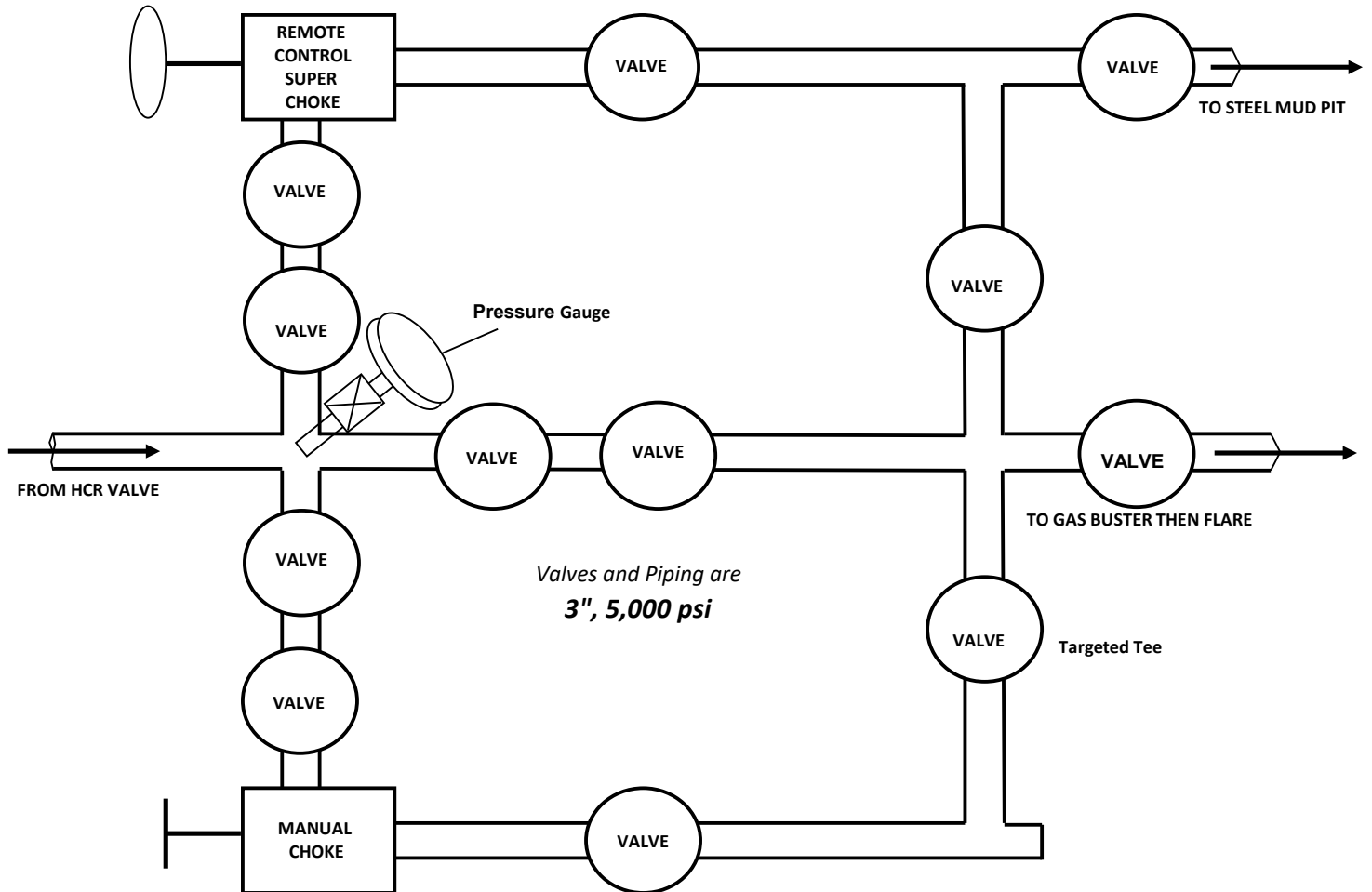

### BOPE DIAGRAM

NOTE: EXACT BOPE AND CHOKE CONFIGURATION AND COMPONENTS MAY DIFFER FROM WHAT IS DEPICTED IN THE DIGRAMS BELOW DEPENDING ON THE RIG AND ITS ASSOCIATED EQUIPMENT. RAM PREVENTERS, ANNULAR PREVENTERS, AND CHOKE MANIFOLD AND COMPONENTS WILL BE RATED TO 3,000 PSI MINIMUM.

### BOPE

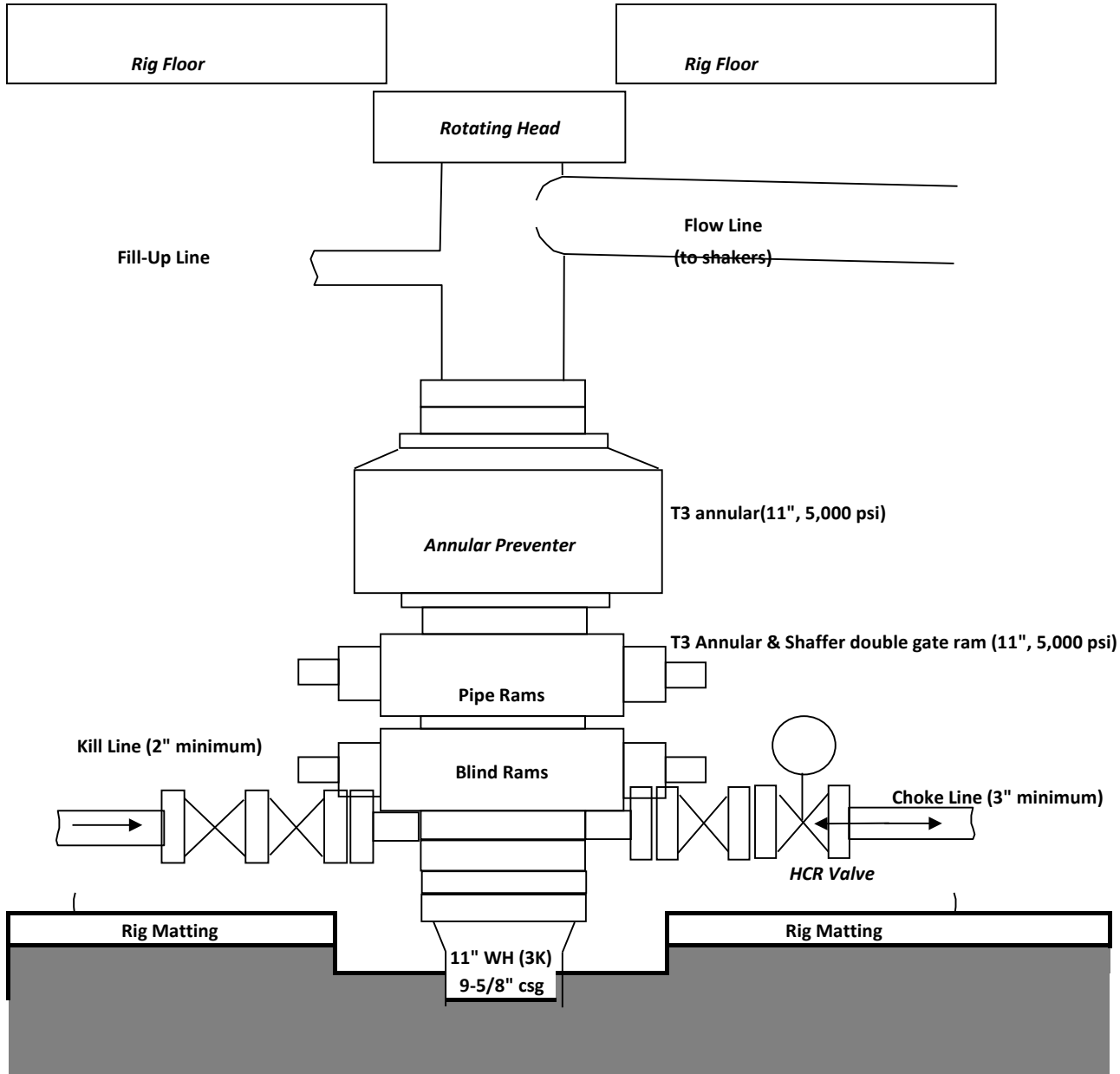



## Enduring Resources, LLC

North Alamito Unit 560H  
Unit Agreement No. NMNM135229A  
Lease No. NMNM16586  
Anticollision Report – Supplement Information

This information is provided as part of the Anticollision Report for the North Alamito Unit 560H APD to identify current methods, procedures, and standards for well intersection planning during drilling and completion operations.

A site-specific analysis of the Federal I #003, API 30-043-20336 did not identify an accurate inclination survey. Assuming a southward drift of the well surveys based on a northward formation dip, distance from the proposed path of the Enduring North Alamito Unit 560H should be in the order of approximately +125' from the Federal I #003. The possibility of a direct impact is low.

Enduring will continually track wellbore survey accuracy to maintain an acceptable range and bearing for collision avoidance. Quality control procedures for ensuring accurate measurement such as calibration, rotational check, need for standby tools, and elevated borehole temperatures will be identified for each section of the North Alamito Unit 560H wellbore and will be available for inspection at the drilling site.

Enduring will provide a 30-day Notification prior to conducting completion operations to offset operators within a one-mile radius of the proposed North Alamito Unit 560H for them to take appropriate and necessary mitigation measures to secure and protect their well(s) from any potential impacts which may be caused by stimulation procedures.



**Well:** North Alamito Unit 560H  
**Site:** North Alamito Unit (560, 562 & 563)  
**Project:** Sandoval County, New Mexico NAD83 NM C  
**Design:** rev0  
**Rig:**

Geodetic System: US State Plane 1983  
 Datum: North American Datum 1983  
 Ellipsoid: GRS 1980  
 Zone: New Mexico Central Zone  
 System Datum: Mean Sea Level  
 Depth Reference: RKB=6876+23.5 @ 6899.50ft



Azimuths to Grid North  
 True North: 0.79°  
 Magnetic North: 9.06°

Magnetic Field  
 Strength: 48869.7nT  
 Dip Angle: 62.63°  
 Date: 8/29/2025  
 Model: IGRF2020

Surface location:  
 Northing 1886772.51 Easting 1245338.91 Latitude 36.17797300 Longitude -107.58868100

Total Corr (M->G): To convert a Magnetic Direction to a Grid Direction, Add 9.064°

**CASING DETAILS**

TVD	MD	Name
350.00	350.00	9-5/8" Surface Casing
5091.94	5471.00	7" Intermediate Casing

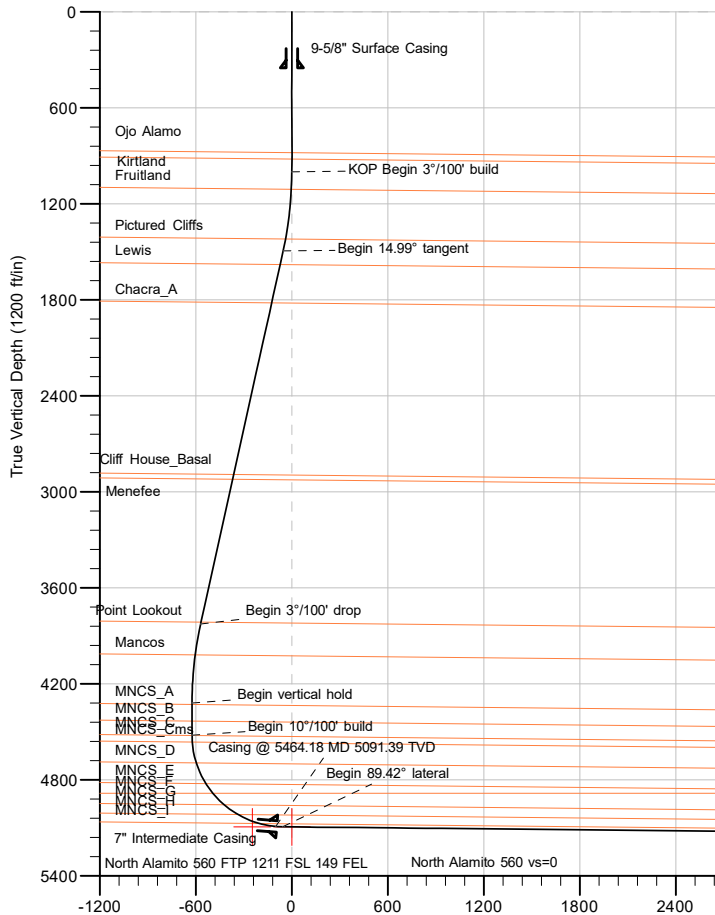

**Section Details**

Sec	MD	Inc	Azi	TVD	+N/-S	+E/-W	Dleg	TFace	VSect	Annotation
1	0.00	0.00	0.000	0.00	0.00	0.00	0.00	0.000	0.00	
2	1000.00	0.00	0.000	1000.00	0.00	0.00	0.00	0.000	0.00	KOP Begin 3°/100' build
3	1499.76	14.99	314.797	1494.07	45.81	-46.13	3.00	314.797	-53.69	Begin 14.99° tangent
4	3914.42	14.99	314.797	3826.54	485.94	-489.41	0.00	0.000	-569.56	Begin 3°/100' drop
5	4414.18	0.00	0.000	4320.61	531.75	-535.54	3.00	180.000	-623.25	Begin vertical hold
6	4614.18	0.00	0.000	4520.61	531.75	-535.54	0.00	0.000	-623.25	Begin 10°/100' build
7	5464.18	85.00	100.470	5091.39	436.71	-21.23	10.00	100.470	-100.23	Casing @ 5464.18 MD 5091.39 TVD
8	5508.42	89.42	100.470	5093.54	428.68	22.21	10.00	-0.002	-56.06	Begin 89.42° lateral
9	10030.35	89.42	100.470	5139.00	-393.00	4468.64	0.00	0.000	4465.65	PBHL/TD @ 10030.35 MD 5139.00 TVD

**DESIGN TARGET DETAILS**

Name	TVD	+N/-S	+E/-W	Northing	Easting	Latitude	Longitude
North Alamito 560 FTP 1211 FSL 149 FEL	5094.00	463.24	-164.82	1887235.75	1245174.09	36.17923900	-107.58926100
North Alamito 560 vs=0	5094.00	418.49	77.34	1887191.00	1245416.25	36.17912527	-107.58843856
North Alamito 560 LTP 441 FSL 753 FEL	5139.00	-393.00	4468.64	1886379.52	1249807.54	36.17706200	-107.57352500

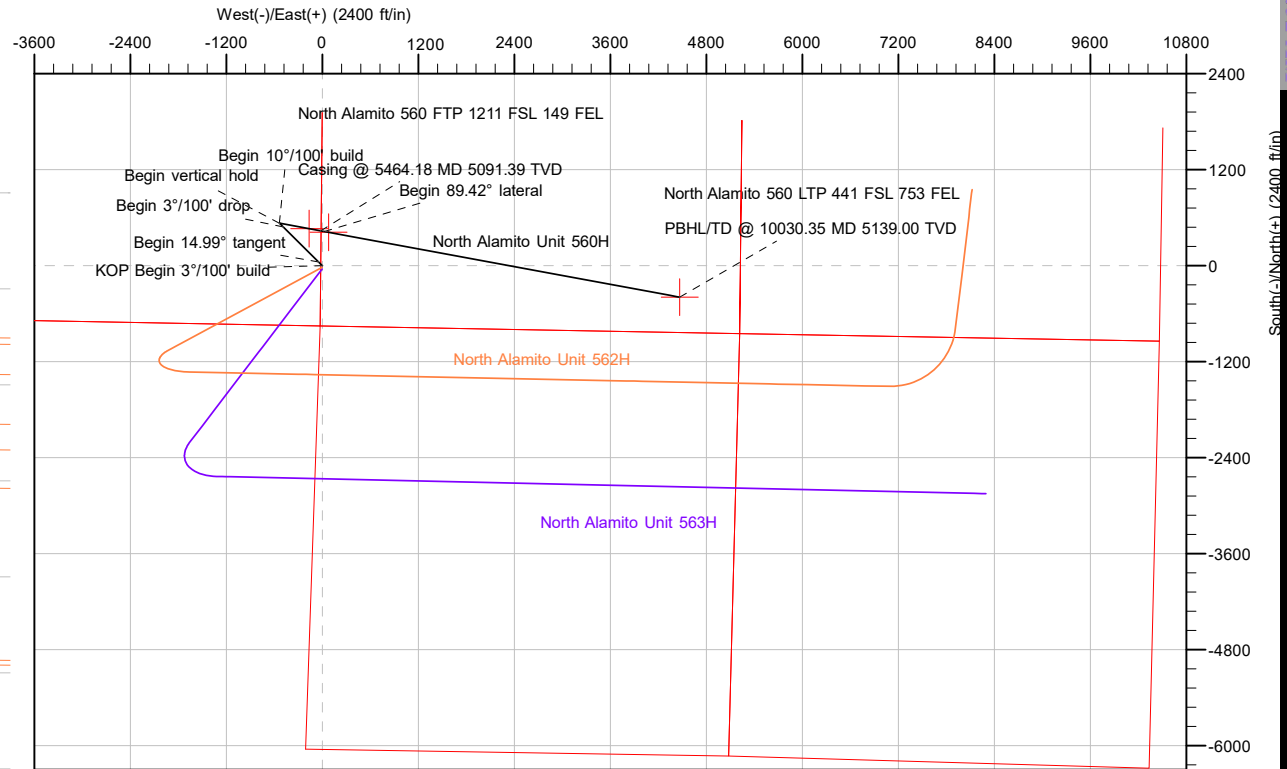

Vertical Section at 100.470° (1200 ft/in)



Planning Report

<b>Database:</b>	DT-Jun1425_v17	<b>Local Co-ordinate Reference:</b>	Site North Alamito Unit (560, 562 & 563)
<b>Company:</b>	Enduring Resources LLC	<b>TVD Reference:</b>	RKB=6876+23.5 @ 6899.50ft
<b>Project:</b>	Sandoval County, New Mexico NAD83 NM C	<b>MD Reference:</b>	RKB=6876+23.5 @ 6899.50ft
<b>Site:</b>	North Alamito Unit (560, 562 & 563)	<b>North Reference:</b>	Grid
<b>Well:</b>	North Alamito Unit 560H	<b>Survey Calculation Method:</b>	Minimum Curvature
<b>Wellbore:</b>	Original Hole		
<b>Design:</b>	rev0		

<b>Project</b>	Sandoval County, New Mexico NAD83 NM C		
<b>Map System:</b>	US State Plane 1983	<b>System Datum:</b>	Mean Sea Level
<b>Geo Datum:</b>	North American Datum 1983		
<b>Map Zone:</b>	New Mexico Central Zone		

<b>Site</b>	North Alamito Unit (560, 562 & 563)				
<b>Site Position:</b>		<b>Northing:</b>	1,886,772.52 usft	<b>Latitude:</b>	36.17797300
<b>From:</b>	Lat/Long	<b>Easting:</b>	1,245,338.91 usft	<b>Longitude:</b>	-107.58868100
<b>Position Uncertainty:</b>	0.00 ft	<b>Slot Radius:</b>	13-3/16 "		

<b>Well</b>	North Alamito Unit 560H, Surf loc: 752 FSL 21 FWL Section 33-T23N-R07W					
<b>Well Position</b>	<b>+N/-S</b>	0.00 ft	<b>Northing:</b>	1,886,772.52 usft	<b>Latitude:</b>	36.17797300
	<b>+E/-W</b>	0.00 ft	<b>Easting:</b>	1,245,338.91 usft	<b>Longitude:</b>	-107.58868100
<b>Position Uncertainty</b>		0.00 ft	<b>Wellhead Elevation:</b>	ft	<b>Ground Level:</b>	6,876.00 ft
<b>Grid Convergence:</b>	-0.790 °					

<b>Wellbore</b>	Original Hole				
<b>Magnetics</b>	<b>Model Name</b>	<b>Sample Date</b>	<b>Declination (°)</b>	<b>Dip Angle (°)</b>	<b>Field Strength (nT)</b>
	IGRF2020	8/29/2025	8.273	62.628	48,869.69515053

<b>Design</b>	rev0			
<b>Audit Notes:</b>				
<b>Version:</b>	<b>Phase:</b>	PLAN	<b>Tie On Depth:</b>	0.00
<b>Vertical Section:</b>	<b>Depth From (TVD) (ft)</b>	<b>+N/-S (ft)</b>	<b>+E/-W (ft)</b>	<b>Direction (°)</b>
	0.00	0.00	0.00	100.470

<b>Plan Survey Tool Program</b>	<b>Date</b>	8/29/2025		
<b>Depth From (ft)</b>	<b>Depth To (ft)</b>	<b>Survey (Wellbore)</b>	<b>Tool Name</b>	<b>Remarks</b>
1	0.00	10,030.35	rev0 (Original Hole)	MWD OWSG MWD - Standard



Planning Report

<b>Database:</b>	DT-Jun1425_v17	<b>Local Co-ordinate Reference:</b>	Site North Alamito Unit (560, 562 & 563)
<b>Company:</b>	Enduring Resources LLC	<b>TVD Reference:</b>	RKB=6876+23.5 @ 6899.50ft
<b>Project:</b>	Sandoval County, New Mexico NAD83 NM C	<b>MD Reference:</b>	RKB=6876+23.5 @ 6899.50ft
<b>Site:</b>	North Alamito Unit (560, 562 & 563)	<b>North Reference:</b>	Grid
<b>Well:</b>	North Alamito Unit 560H	<b>Survey Calculation Method:</b>	Minimum Curvature
<b>Wellbore:</b>	Original Hole		
<b>Design:</b>	rev0		

Plan Sections										
Measured Depth (ft)	Inclination (°)	Azimuth (°)	Vertical Depth (ft)	+N/-S (ft)	+E/-W (ft)	Dogleg Rate (°/100ft)	Build Rate (°/100ft)	Turn Rate (°/100ft)	TFO (°)	Target
0.00	0.00	0.000	0.00	0.00	0.00	0.00	0.00	0.00	0.000	
1,000.00	0.00	0.000	1,000.00	0.00	0.00	0.00	0.00	0.00	0.000	
1,499.76	14.99	314.797	1,494.07	45.81	-46.13	3.00	3.00	0.00	314.797	
3,914.42	14.99	314.797	3,826.54	485.94	-489.41	0.00	0.00	0.00	0.000	
4,414.18	0.00	0.000	4,320.61	531.75	-535.54	3.00	-3.00	0.00	180.000	
4,614.18	0.00	0.000	4,520.61	531.75	-535.54	0.00	0.00	0.00	0.000	
5,464.18	85.00	100.470	5,091.39	436.71	-21.23	10.00	10.00	0.00	100.470	
5,508.42	89.42	100.470	5,093.54	428.68	22.21	10.00	10.00	0.00	-0.002	
10,030.35	89.42	100.470	5,139.00	-393.00	4,468.64	0.00	0.00	0.00	0.000	North Alamito 560 LTF



Planning Report

<b>Database:</b>	DT-Jun1425_v17	<b>Local Co-ordinate Reference:</b>	Site North Alamito Unit (560, 562 & 563)
<b>Company:</b>	Enduring Resources LLC	<b>TVD Reference:</b>	RKB=6876+23.5 @ 6899.50ft
<b>Project:</b>	Sandoval County, New Mexico NAD83 NM C	<b>MD Reference:</b>	RKB=6876+23.5 @ 6899.50ft
<b>Site:</b>	North Alamito Unit (560, 562 & 563)	<b>North Reference:</b>	Grid
<b>Well:</b>	North Alamito Unit 560H	<b>Survey Calculation Method:</b>	Minimum Curvature
<b>Wellbore:</b>	Original Hole		
<b>Design:</b>	rev0		

Planned Survey										
Measured Depth (ft)	Inclination (°)	Azimuth (°)	Vertical Depth (ft)	+N/-S (ft)	+E/-W (ft)	Vertical Section (ft)	Dogleg Rate (°/100ft)	Build Rate (°/100ft)	Turn Rate (°/100ft)	
0.00	0.00	0.000	0.00	0.00	0.00	0.00	0.00	0.00	0.00	
100.00	0.00	0.000	100.00	0.00	0.00	0.00	0.00	0.00	0.00	
200.00	0.00	0.000	200.00	0.00	0.00	0.00	0.00	0.00	0.00	
300.00	0.00	0.000	300.00	0.00	0.00	0.00	0.00	0.00	0.00	
350.00	0.00	0.000	350.00	0.00	0.00	0.00	0.00	0.00	0.00	
<b>9-5/8" Surface Casing</b>										
400.00	0.00	0.000	400.00	0.00	0.00	0.00	0.00	0.00	0.00	
500.00	0.00	0.000	500.00	0.00	0.00	0.00	0.00	0.00	0.00	
600.00	0.00	0.000	600.00	0.00	0.00	0.00	0.00	0.00	0.00	
700.00	0.00	0.000	700.00	0.00	0.00	0.00	0.00	0.00	0.00	
800.00	0.00	0.000	800.00	0.00	0.00	0.00	0.00	0.00	0.00	
880.00	0.00	0.000	880.00	0.00	0.00	0.00	0.00	0.00	0.00	
<b>Ojo Alamo</b>										
900.00	0.00	0.000	900.00	0.00	0.00	0.00	0.00	0.00	0.00	
920.00	0.00	0.000	920.00	0.00	0.00	0.00	0.00	0.00	0.00	
<b>Kirtland</b>										
1,000.00	0.00	0.000	1,000.00	0.00	0.00	0.00	0.00	0.00	0.00	
<b>KOP Begin 3°/100' build</b>										
1,100.00	3.00	314.797	1,099.95	1.84	-1.86	-2.16	3.00	3.00	0.00	
1,110.03	3.30	314.797	1,109.97	2.23	-2.25	-2.62	3.00	3.00	0.00	
<b>Fruitland</b>										
1,200.00	6.00	314.797	1,199.63	7.37	-7.42	-8.64	3.00	3.00	0.00	
1,300.00	9.00	314.797	1,298.77	16.57	-16.69	-19.42	3.00	3.00	0.00	
1,400.00	12.00	314.797	1,397.08	29.41	-29.62	-34.47	3.00	3.00	0.00	
1,423.06	12.69	314.797	1,419.61	32.88	-33.11	-38.54	3.00	3.00	0.00	
<b>Pictured Cliffs</b>										
1,499.76	14.99	314.797	1,494.07	45.81	-46.13	-53.69	3.00	3.00	0.00	
<b>Begin 14.99° tangent</b>										
1,587.95	14.99	314.797	1,579.27	61.88	-62.33	-72.53	0.00	0.00	0.00	
<b>Lewis</b>										
1,600.00	14.99	314.797	1,590.90	64.08	-64.54	-75.11	0.00	0.00	0.00	
1,700.00	14.99	314.797	1,687.50	82.31	-82.89	-96.47	0.00	0.00	0.00	
1,800.00	14.99	314.797	1,784.10	100.54	-101.25	-117.84	0.00	0.00	0.00	
1,835.85	14.99	314.797	1,818.73	107.07	-107.83	-125.50	0.00	0.00	0.00	
<b>Chacra_A</b>										
1,900.00	14.99	314.797	1,880.69	118.76	-119.61	-139.20	0.00	0.00	0.00	
2,000.00	14.99	314.797	1,977.29	136.99	-137.97	-160.56	0.00	0.00	0.00	
2,100.00	14.99	314.797	2,073.88	155.22	-156.32	-181.93	0.00	0.00	0.00	
2,200.00	14.99	314.797	2,170.48	173.45	-174.68	-203.29	0.00	0.00	0.00	
2,300.00	14.99	314.797	2,267.07	191.67	-193.04	-224.66	0.00	0.00	0.00	
2,400.00	14.99	314.797	2,363.67	209.90	-211.40	-246.02	0.00	0.00	0.00	
2,500.00	14.99	314.797	2,460.27	228.13	-229.75	-267.38	0.00	0.00	0.00	
2,600.00	14.99	314.797	2,556.86	246.36	-248.11	-288.75	0.00	0.00	0.00	
2,700.00	14.99	314.797	2,653.46	264.58	-266.47	-310.11	0.00	0.00	0.00	
2,800.00	14.99	314.797	2,750.05	282.81	-284.83	-331.48	0.00	0.00	0.00	
2,900.00	14.99	314.797	2,846.65	301.04	-303.18	-352.84	0.00	0.00	0.00	
2,946.25	14.99	314.797	2,891.33	309.47	-311.67	-362.72	0.00	0.00	0.00	
<b>Cliff House_Basal</b>										
2,977.24	14.99	314.797	2,921.26	315.12	-317.36	-369.34	0.00	0.00	0.00	
<b>Menefee</b>										
3,000.00	14.99	314.797	2,943.25	319.27	-321.54	-374.20	0.00	0.00	0.00	
3,100.00	14.99	314.797	3,039.84	337.49	-339.90	-395.57	0.00	0.00	0.00	
3,200.00	14.99	314.797	3,136.44	355.72	-358.26	-416.93	0.00	0.00	0.00	



Planning Report

<b>Database:</b>	DT-Jun1425_v17	<b>Local Co-ordinate Reference:</b>	Site North Alamito Unit (560, 562 & 563)
<b>Company:</b>	Enduring Resources LLC	<b>TVD Reference:</b>	RKB=6876+23.5 @ 6899.50ft
<b>Project:</b>	Sandoval County, New Mexico NAD83 NM C	<b>MD Reference:</b>	RKB=6876+23.5 @ 6899.50ft
<b>Site:</b>	North Alamito Unit (560, 562 & 563)	<b>North Reference:</b>	Grid
<b>Well:</b>	North Alamito Unit 560H	<b>Survey Calculation Method:</b>	Minimum Curvature
<b>Wellbore:</b>	Original Hole		
<b>Design:</b>	rev0		

Planned Survey										
Measured Depth (ft)	Inclination (°)	Azimuth (°)	Vertical Depth (ft)	+N/-S (ft)	+E/-W (ft)	Vertical Section (ft)	Dogleg Rate (°/100ft)	Build Rate (°/100ft)	Turn Rate (°/100ft)	
3,300.00	14.99	314.797	3,233.03	373.95	-376.61	-438.30	0.00	0.00	0.00	
3,400.00	14.99	314.797	3,329.63	392.18	-394.97	-459.66	0.00	0.00	0.00	
3,500.00	14.99	314.797	3,426.23	410.40	-413.33	-481.03	0.00	0.00	0.00	
3,600.00	14.99	314.797	3,522.82	428.63	-431.69	-502.39	0.00	0.00	0.00	
3,700.00	14.99	314.797	3,619.42	446.86	-450.04	-523.75	0.00	0.00	0.00	
3,800.00	14.99	314.797	3,716.01	465.09	-468.40	-545.12	0.00	0.00	0.00	
3,900.00	14.99	314.797	3,812.61	483.31	-486.76	-566.48	0.00	0.00	0.00	
3,901.71	14.99	314.797	3,814.26	483.63	-487.07	-566.85	0.00	0.00	0.00	
<b>Point Lookout</b>										
3,914.42	14.99	314.797	3,826.54	485.94	-489.41	-569.56	0.00	0.00	0.00	
<b>Begin 3°/100' drop</b>										
4,000.00	12.43	314.797	3,909.67	500.23	-503.80	-586.31	3.00	-3.00	0.00	
4,100.00	9.43	314.797	4,007.85	513.58	-517.24	-601.96	3.00	-3.00	0.00	
4,111.19	9.09	314.797	4,018.89	514.85	-518.52	-603.45	3.00	-3.00	0.00	
<b>Mancos</b>										
4,200.00	6.43	314.797	4,106.88	523.30	-527.03	-613.35	3.00	-3.00	0.00	
4,300.00	3.43	314.797	4,206.50	529.35	-533.12	-620.44	3.00	-3.00	0.00	
4,400.00	0.43	314.797	4,306.43	531.71	-535.50	-623.21	3.00	-3.00	0.00	
4,414.18	0.00	0.000	4,320.61	531.75	-535.54	-623.25	3.00	-3.00	0.00	
<b>Begin vertical hold</b>										
4,422.26	0.00	0.000	4,328.69	531.75	-535.54	-623.25	0.00	0.00	0.00	
<b>MNCS_A</b>										
4,500.00	0.00	0.000	4,406.43	531.75	-535.54	-623.25	0.00	0.00	0.00	
4,527.26	0.00	0.000	4,433.69	531.75	-535.54	-623.25	0.00	0.00	0.00	
<b>MNCS_B</b>										
4,600.00	0.00	0.000	4,506.43	531.75	-535.54	-623.25	0.00	0.00	0.00	
4,614.18	0.00	0.000	4,520.61	531.75	-535.54	-623.25	0.00	0.00	0.00	
<b>Begin 10°/100' build</b>										
4,617.26	0.31	100.470	4,523.69	531.75	-535.53	-623.25	10.00	10.00	0.00	
<b>MNCS_C</b>										
4,650.00	3.58	100.470	4,556.41	531.55	-534.44	-622.13	10.00	10.00	0.00	
4,657.31	4.31	100.470	4,563.71	531.46	-533.94	-621.63	10.00	10.00	0.00	
<b>MNCS_Cms</b>										
4,700.00	8.58	100.470	4,606.11	530.58	-529.23	-616.84	10.00	10.00	0.00	
4,750.00	13.58	100.470	4,655.17	528.84	-519.78	-607.23	10.00	10.00	0.00	
4,790.29	17.61	100.470	4,693.96	526.87	-509.13	-596.40	10.00	10.00	0.00	
<b>MNCS_D</b>										
4,800.00	18.58	100.470	4,703.19	526.32	-506.17	-593.38	10.00	10.00	0.00	
4,850.00	23.58	100.470	4,749.83	523.05	-488.49	-575.40	10.00	10.00	0.00	
4,900.00	28.58	100.470	4,794.73	519.06	-466.88	-553.43	10.00	10.00	0.00	
4,934.58	32.04	100.470	4,824.57	515.89	-449.72	-535.98	10.00	10.00	0.00	
<b>MNCS_E</b>										
4,950.00	33.58	100.470	4,837.53	514.37	-441.50	-527.62	10.00	10.00	0.00	
5,000.00	38.58	100.470	4,877.93	509.02	-412.55	-498.18	10.00	10.00	0.00	
5,009.10	39.49	100.470	4,885.00	507.98	-406.91	-492.45	10.00	10.00	0.00	
<b>MNCS_F</b>										
5,050.00	43.58	100.470	4,915.61	503.05	-380.25	-465.34	10.00	10.00	0.00	
5,100.00	48.58	100.470	4,950.28	496.51	-344.85	-429.33	10.00	10.00	0.00	
5,108.29	49.41	100.470	4,955.72	495.37	-338.69	-423.07	10.00	10.00	0.00	
<b>MNCS_G</b>										
5,150.00	53.58	100.470	4,981.68	489.44	-306.60	-390.44	10.00	10.00	0.00	
5,200.00	58.58	100.470	5,009.57	481.91	-265.82	-348.96	10.00	10.00	0.00	



Planning Report

<b>Database:</b>	DT-Jun1425_v17	<b>Local Co-ordinate Reference:</b>	Site North Alamito Unit (560, 562 & 563)
<b>Company:</b>	Enduring Resources LLC	<b>TVD Reference:</b>	RKB=6876+23.5 @ 6899.50ft
<b>Project:</b>	Sandoval County, New Mexico NAD83 NM C	<b>MD Reference:</b>	RKB=6876+23.5 @ 6899.50ft
<b>Site:</b>	North Alamito Unit (560, 562 & 563)	<b>North Reference:</b>	Grid
<b>Well:</b>	North Alamito Unit 560H	<b>Survey Calculation Method:</b>	Minimum Curvature
<b>Wellbore:</b>	Original Hole		
<b>Design:</b>	rev0		

Planned Survey										
Measured Depth (ft)	Inclination (°)	Azimuth (°)	Vertical Depth (ft)	+N/-S (ft)	+E/-W (ft)	Vertical Section (ft)	Dogleg Rate (°/100ft)	Build Rate (°/100ft)	Turn Rate (°/100ft)	
5,213.74	59.96	100.470	5,016.59	479.76	-254.20	-337.15	10.00	10.00	0.00	
<b>MNCS_H</b>										
5,250.00	63.58	100.470	5,033.74	473.96	-222.79	-305.21	10.00	10.00	0.00	
5,300.00	68.58	100.470	5,054.00	465.65	-177.86	-259.52	10.00	10.00	0.00	
5,350.00	73.58	100.470	5,070.21	457.06	-131.36	-212.23	10.00	10.00	0.00	
5,360.00	74.58	100.470	5,072.95	455.31	-121.91	-202.62	10.00	10.00	0.00	
<b>MNCS_I</b>										
5,400.00	78.58	100.470	5,082.23	448.24	-83.66	-163.72	10.00	10.00	0.00	
5,450.00	83.58	100.470	5,089.98	439.27	-35.10	-114.34	10.00	10.00	0.00	
5,464.18	85.00	100.470	5,091.39	436.71	-21.23	-100.23	10.00	10.00	0.00	
<b>Casing @ 5464.18 MD 5091.39 TVD</b>										
5,471.00	85.68	100.470	5,091.94	435.47	-14.54	-93.43	10.00	10.00	0.00	
<b>7" Intermediate Casing</b>										
5,500.00	88.58	100.470	5,093.39	430.21	13.94	-64.47	10.00	10.00	0.00	
5,508.42	89.42	100.470	5,093.54	428.68	22.21	-56.06	10.00	10.00	0.00	
<b>Begin 89.42° lateral</b>										
5,600.00	89.42	100.470	5,094.46	412.04	112.27	35.52	0.00	0.00	0.00	
5,700.00	89.42	100.470	5,095.47	393.87	210.60	135.52	0.00	0.00	0.00	
5,800.00	89.42	100.470	5,096.47	375.70	308.93	235.51	0.00	0.00	0.00	
5,900.00	89.42	100.470	5,097.48	357.52	407.26	335.51	0.00	0.00	0.00	
6,000.00	89.42	100.470	5,098.48	339.35	505.59	435.50	0.00	0.00	0.00	
6,100.00	89.42	100.470	5,099.49	321.18	603.92	535.50	0.00	0.00	0.00	
6,200.00	89.42	100.470	5,100.49	303.01	702.25	635.49	0.00	0.00	0.00	
6,300.00	89.42	100.470	5,101.50	284.84	800.58	735.49	0.00	0.00	0.00	
6,400.00	89.42	100.470	5,102.50	266.67	898.91	835.48	0.00	0.00	0.00	
6,500.00	89.42	100.470	5,103.51	248.50	997.24	935.48	0.00	0.00	0.00	
6,600.00	89.42	100.470	5,104.51	230.33	1,095.57	1,035.47	0.00	0.00	0.00	
6,700.00	89.42	100.470	5,105.52	212.16	1,193.90	1,135.47	0.00	0.00	0.00	
6,800.00	89.42	100.470	5,106.52	193.99	1,292.23	1,235.46	0.00	0.00	0.00	
6,900.00	89.42	100.470	5,107.53	175.82	1,390.56	1,335.46	0.00	0.00	0.00	
7,000.00	89.42	100.470	5,108.53	157.64	1,488.89	1,435.45	0.00	0.00	0.00	
7,100.00	89.42	100.470	5,109.54	139.47	1,587.22	1,535.45	0.00	0.00	0.00	
7,200.00	89.42	100.470	5,110.55	121.30	1,685.55	1,635.44	0.00	0.00	0.00	
7,300.00	89.42	100.470	5,111.55	103.13	1,783.88	1,735.44	0.00	0.00	0.00	
7,400.00	89.42	100.470	5,112.56	84.96	1,882.21	1,835.43	0.00	0.00	0.00	
7,500.00	89.42	100.470	5,113.56	66.79	1,980.54	1,935.43	0.00	0.00	0.00	
7,600.00	89.42	100.470	5,114.57	48.62	2,078.87	2,035.42	0.00	0.00	0.00	
7,700.00	89.42	100.470	5,115.57	30.45	2,177.20	2,135.42	0.00	0.00	0.00	
7,800.00	89.42	100.470	5,116.58	12.28	2,275.53	2,235.41	0.00	0.00	0.00	
7,900.00	89.42	100.470	5,117.58	-5.89	2,373.86	2,335.41	0.00	0.00	0.00	
8,000.00	89.42	100.470	5,118.59	-24.06	2,472.19	2,435.40	0.00	0.00	0.00	
8,100.00	89.42	100.470	5,119.59	-42.24	2,570.52	2,535.40	0.00	0.00	0.00	
8,200.00	89.42	100.470	5,120.60	-60.41	2,668.85	2,635.39	0.00	0.00	0.00	
8,300.00	89.42	100.470	5,121.60	-78.58	2,767.18	2,735.39	0.00	0.00	0.00	
8,400.00	89.42	100.470	5,122.61	-96.75	2,865.51	2,835.38	0.00	0.00	0.00	
8,500.00	89.42	100.470	5,123.61	-114.92	2,963.84	2,935.38	0.00	0.00	0.00	
8,600.00	89.42	100.470	5,124.62	-133.09	3,062.17	3,035.37	0.00	0.00	0.00	
8,700.00	89.42	100.470	5,125.63	-151.26	3,160.50	3,135.37	0.00	0.00	0.00	
8,800.00	89.42	100.470	5,126.63	-169.43	3,258.83	3,235.36	0.00	0.00	0.00	
8,900.00	89.42	100.470	5,127.64	-187.60	3,357.16	3,335.36	0.00	0.00	0.00	
9,000.00	89.42	100.470	5,128.64	-205.77	3,455.49	3,435.35	0.00	0.00	0.00	
9,100.00	89.42	100.470	5,129.65	-223.94	3,553.82	3,535.35	0.00	0.00	0.00	
9,200.00	89.42	100.470	5,130.65	-242.12	3,652.15	3,635.34	0.00	0.00	0.00	
9,300.00	89.42	100.470	5,131.66	-260.29	3,750.48	3,735.34	0.00	0.00	0.00	



Planning Report

<b>Database:</b>	DT-Jun1425_v17	<b>Local Co-ordinate Reference:</b>	Site North Alamito Unit (560, 562 & 563)
<b>Company:</b>	Enduring Resources LLC	<b>TVD Reference:</b>	RKB=6876+23.5 @ 6899.50ft
<b>Project:</b>	Sandoval County, New Mexico NAD83 NM C	<b>MD Reference:</b>	RKB=6876+23.5 @ 6899.50ft
<b>Site:</b>	North Alamito Unit (560, 562 & 563)	<b>North Reference:</b>	Grid
<b>Well:</b>	North Alamito Unit 560H	<b>Survey Calculation Method:</b>	Minimum Curvature
<b>Wellbore:</b>	Original Hole		
<b>Design:</b>	rev0		

Planned Survey									
Measured Depth (ft)	Inclination (°)	Azimuth (°)	Vertical Depth (ft)	+N/-S (ft)	+E/-W (ft)	Vertical Section (ft)	Dogleg Rate (°/100ft)	Build Rate (°/100ft)	Turn Rate (°/100ft)
9,400.00	89.42	100.470	5,132.66	-278.46	3,848.81	3,835.33	0.00	0.00	0.00
9,500.00	89.42	100.470	5,133.67	-296.63	3,947.14	3,935.33	0.00	0.00	0.00
9,600.00	89.42	100.470	5,134.67	-314.80	4,045.47	4,035.32	0.00	0.00	0.00
9,700.00	89.42	100.470	5,135.68	-332.97	4,143.80	4,135.32	0.00	0.00	0.00
9,800.00	89.42	100.470	5,136.68	-351.14	4,242.13	4,235.31	0.00	0.00	0.00
9,900.00	89.42	100.470	5,137.69	-369.31	4,340.46	4,335.31	0.00	0.00	0.00
10,000.00	89.42	100.470	5,138.69	-387.48	4,438.79	4,435.30	0.00	0.00	0.00
10,030.35	89.42	100.470	5,139.00	-393.00	4,468.64	4,465.65	0.00	0.00	0.00
PBHL/TD @ 10030.35 MD 5139.00 TVD									

Casing Points					
Measured Depth (ft)	Vertical Depth (ft)	Name	Casing Diameter (")	Hole Diameter (")	
350.00	350.00	9-5/8" Surface Casing	9-5/8	12-1/4	
5,471.00	5,091.94	7" Intermediate Casing	7	8-3/4	

Formations					
Measured Depth (ft)	Vertical Depth (ft)	Name	Lithology	Dip (°)	Dip Direction (°)
880.00	880.00	Ojo Alamo		0.580	100.470
920.00	920.00	Kirtland		0.580	100.470
1,110.03	1,109.97	Fruitland		0.580	100.470
1,423.06	1,419.61	Pictured Cliffs		0.580	100.470
1,587.95	1,579.27	Lewis		0.580	100.470
1,835.85	1,818.73	Chacra_A		0.580	100.470
2,946.25	2,891.33	Cliff House_Basal		0.580	100.470
2,977.24	2,921.26	Menefee		0.580	100.470
3,901.71	3,814.26	Point Lookout		0.580	100.470
4,111.19	4,018.89	Mancos		0.580	100.470
4,422.26	4,328.69	MNCS_A		0.580	100.470
4,527.26	4,433.69	MNCS_B		0.580	100.470
4,617.26	4,523.69	MNCS_C		0.580	100.470
4,657.31	4,563.71	MNCS_Cms		0.580	100.470
4,790.29	4,693.96	MNCS_D		0.580	100.470
4,934.58	4,824.57	MNCS_E		0.580	100.470
5,009.10	4,885.00	MNCS_F		0.000	100.470
5,108.29	4,955.72	MNCS_G		0.580	100.470
5,213.74	5,016.59	MNCS_H		0.580	100.470
5,360.00	5,072.95	MNCS_I		0.580	100.470



Planning Report

<b>Database:</b>	DT-Jun1425_v17	<b>Local Co-ordinate Reference:</b>	Site North Alamito Unit (560, 562 & 563)
<b>Company:</b>	Enduring Resources LLC	<b>TVD Reference:</b>	RKB=6876+23.5 @ 6899.50ft
<b>Project:</b>	Sandoval County, New Mexico NAD83 NM C	<b>MD Reference:</b>	RKB=6876+23.5 @ 6899.50ft
<b>Site:</b>	North Alamito Unit (560, 562 & 563)	<b>North Reference:</b>	Grid
<b>Well:</b>	North Alamito Unit 560H	<b>Survey Calculation Method:</b>	Minimum Curvature
<b>Wellbore:</b>	Original Hole		
<b>Design:</b>	rev0		

Plan Annotations					
Measured Depth (ft)	Vertical Depth (ft)	Local Coordinates		Comment	
		+N/-S (ft)	+E/-W (ft)		
1,000.00	1,000.00	0.00	0.00	KOP Begin 3°/100' build	
1,499.76	1,494.07	45.81	-46.13	Begin 14.99° tangent	
3,914.42	3,826.54	485.94	-489.41	Begin 3°/100' drop	
4,414.18	4,320.61	531.75	-535.54	Begin vertical hold	
4,614.18	4,520.61	531.75	-535.54	Begin 10°/100' build	
5,464.18	5,091.39	436.71	-21.23	Casing @ 5464.18 MD 5091.39 TVD	
5,508.42	5,093.54	428.68	22.21	Begin 89.42° lateral	
10,030.35	5,139.00	-393.00	4,468.64	PBHL/TD @ 10030.35 MD 5139.00 TVD	



Planning Report - Geographic

<b>Database:</b>	DT-Jun1425_v17	<b>Local Co-ordinate Reference:</b>	Site North Alamito Unit (560, 562 & 563)
<b>Company:</b>	Enduring Resources LLC	<b>TVD Reference:</b>	RKB=6876+23.5 @ 6899.50ft
<b>Project:</b>	Sandoval County, New Mexico NAD83 NM C	<b>MD Reference:</b>	RKB=6876+23.5 @ 6899.50ft
<b>Site:</b>	North Alamito Unit (560, 562 & 563)	<b>North Reference:</b>	Grid
<b>Well:</b>	North Alamito Unit 560H	<b>Survey Calculation Method:</b>	Minimum Curvature
<b>Wellbore:</b>	Original Hole		
<b>Design:</b>	rev0		

<b>Project</b>	Sandoval County, New Mexico NAD83 NM C		
<b>Map System:</b>	US State Plane 1983	<b>System Datum:</b>	Mean Sea Level
<b>Geo Datum:</b>	North American Datum 1983		
<b>Map Zone:</b>	New Mexico Central Zone		

<b>Site</b>	North Alamito Unit (560, 562 & 563)				
<b>Site Position:</b>		<b>Northing:</b>	1,886,772.52 usft	<b>Latitude:</b>	36.17797300
<b>From:</b>	Lat/Long	<b>Easting:</b>	1,245,338.91 usft	<b>Longitude:</b>	-107.58868100
<b>Position Uncertainty:</b>	0.00 ft	<b>Slot Radius:</b>	13-3/16 "		

<b>Well</b>	North Alamito Unit 560H, Surf loc: 752 FSL 21 FWL Section 33-T23N-R07W					
<b>Well Position</b>	<b>+N/-S</b>	0.00 ft	<b>Northing:</b>	1,886,772.52 usft	<b>Latitude:</b>	36.17797300
	<b>+E/-W</b>	0.00 ft	<b>Easting:</b>	1,245,338.91 usft	<b>Longitude:</b>	-107.58868100
<b>Position Uncertainty</b>	0.00 ft		<b>Wellhead Elevation:</b>	ft	<b>Ground Level:</b>	6,876.00 ft
<b>Grid Convergence:</b>	-0.790 °					

<b>Wellbore</b>	Original Hole				
<b>Magnetics</b>	<b>Model Name</b>	<b>Sample Date</b>	<b>Declination (°)</b>	<b>Dip Angle (°)</b>	<b>Field Strength (nT)</b>
	IGRF2020	8/29/2025	8.273	62.628	48,869.69515053

<b>Design</b>	rev0				
<b>Audit Notes:</b>					
<b>Version:</b>	<b>Phase:</b>	PLAN	<b>Tie On Depth:</b>	0.00	
<b>Vertical Section:</b>	<b>Depth From (TVD) (ft)</b>	<b>+N/-S (ft)</b>	<b>+E/-W (ft)</b>	<b>Direction (°)</b>	
	0.00	0.00	0.00	100.470	

<b>Plan Survey Tool Program</b>	<b>Date</b>	8/29/2025			
<b>Depth From (ft)</b>	<b>Depth To (ft)</b>	<b>Survey (Wellbore)</b>	<b>Tool Name</b>	<b>Remarks</b>	
1	0.00	10,030.35 rev0 (Original Hole)	MWD	OWSG MWD - Standard	



Planning Report - Geographic

<b>Database:</b>	DT-Jun1425_v17	<b>Local Co-ordinate Reference:</b>	Site North Alamito Unit (560, 562 & 563)
<b>Company:</b>	Enduring Resources LLC	<b>TVD Reference:</b>	RKB=6876+23.5 @ 6899.50ft
<b>Project:</b>	Sandoval County, New Mexico NAD83 NM C	<b>MD Reference:</b>	RKB=6876+23.5 @ 6899.50ft
<b>Site:</b>	North Alamito Unit (560, 562 & 563)	<b>North Reference:</b>	Grid
<b>Well:</b>	North Alamito Unit 560H	<b>Survey Calculation Method:</b>	Minimum Curvature
<b>Wellbore:</b>	Original Hole		
<b>Design:</b>	rev0		

Plan Sections										
Measured Depth (ft)	Inclination (°)	Azimuth (°)	Vertical Depth (ft)	+N/-S (ft)	+E/-W (ft)	Dogleg Rate (°/100ft)	Build Rate (°/100ft)	Turn Rate (°/100ft)	TFO (°)	Target
0.00	0.00	0.000	0.00	0.00	0.00	0.00	0.00	0.00	0.000	
1,000.00	0.00	0.000	1,000.00	0.00	0.00	0.00	0.00	0.00	0.000	
1,499.76	14.99	314.797	1,494.07	45.81	-46.13	3.00	3.00	0.00	314.797	
3,914.42	14.99	314.797	3,826.54	485.94	-489.41	0.00	0.00	0.00	0.000	
4,414.18	0.00	0.000	4,320.61	531.75	-535.54	3.00	-3.00	0.00	180.000	
4,614.18	0.00	0.000	4,520.61	531.75	-535.54	0.00	0.00	0.00	0.000	
5,464.18	85.00	100.470	5,091.39	436.71	-21.23	10.00	10.00	0.00	100.470	
5,508.42	89.42	100.470	5,093.54	428.68	22.21	10.00	10.00	0.00	-0.002	
10,030.35	89.42	100.470	5,139.00	-393.00	4,468.64	0.00	0.00	0.00	0.000	North Alamito 560 LTF



Planning Report - Geographic

<b>Database:</b>	DT-Jun1425_v17	<b>Local Co-ordinate Reference:</b>	Site North Alamito Unit (560, 562 & 563)
<b>Company:</b>	Enduring Resources LLC	<b>TVD Reference:</b>	RKB=6876+23.5 @ 6899.50ft
<b>Project:</b>	Sandoval County, New Mexico NAD83 NM C	<b>MD Reference:</b>	RKB=6876+23.5 @ 6899.50ft
<b>Site:</b>	North Alamito Unit (560, 562 & 563)	<b>North Reference:</b>	Grid
<b>Well:</b>	North Alamito Unit 560H	<b>Survey Calculation Method:</b>	Minimum Curvature
<b>Wellbore:</b>	Original Hole		
<b>Design:</b>	rev0		

Planned Survey										
Measured Depth (ft)	Inclination (°)	Azimuth (°)	Vertical Depth (ft)	+N/-S (ft)	+E/-W (ft)	Map Northing (usft)	Map Easting (usft)	Latitude	Longitude	
0.00	0.00	0.000	0.00	0.00	0.00	1,886,772.52	1,245,338.91	36.17797300	-107.58868100	
100.00	0.00	0.000	100.00	0.00	0.00	1,886,772.52	1,245,338.91	36.17797300	-107.58868100	
200.00	0.00	0.000	200.00	0.00	0.00	1,886,772.52	1,245,338.91	36.17797300	-107.58868100	
300.00	0.00	0.000	300.00	0.00	0.00	1,886,772.52	1,245,338.91	36.17797300	-107.58868100	
350.00	0.00	0.000	350.00	0.00	0.00	1,886,772.52	1,245,338.91	36.17797300	-107.58868100	
<b>9-5/8" Surface Casing</b>										
400.00	0.00	0.000	400.00	0.00	0.00	1,886,772.52	1,245,338.91	36.17797300	-107.58868100	
500.00	0.00	0.000	500.00	0.00	0.00	1,886,772.52	1,245,338.91	36.17797300	-107.58868100	
600.00	0.00	0.000	600.00	0.00	0.00	1,886,772.52	1,245,338.91	36.17797300	-107.58868100	
700.00	0.00	0.000	700.00	0.00	0.00	1,886,772.52	1,245,338.91	36.17797300	-107.58868100	
800.00	0.00	0.000	800.00	0.00	0.00	1,886,772.52	1,245,338.91	36.17797300	-107.58868100	
880.00	0.00	0.000	880.00	0.00	0.00	1,886,772.52	1,245,338.91	36.17797300	-107.58868100	
<b>Ojo Alamo</b>										
900.00	0.00	0.000	900.00	0.00	0.00	1,886,772.52	1,245,338.91	36.17797300	-107.58868100	
920.00	0.00	0.000	920.00	0.00	0.00	1,886,772.52	1,245,338.91	36.17797300	-107.58868100	
<b>Kirtland</b>										
1,000.00	0.00	0.000	1,000.00	0.00	0.00	1,886,772.52	1,245,338.91	36.17797300	-107.58868100	
<b>KOP Begin 3°/100' build</b>										
1,100.00	3.00	314.797	1,099.95	1.84	-1.86	1,886,774.36	1,245,337.05	36.17797799	-107.58868738	
1,110.03	3.30	314.797	1,109.97	2.23	-2.25	1,886,774.75	1,245,336.66	36.17797905	-107.58868873	
<b>Fruitland</b>										
1,200.00	6.00	314.797	1,199.63	7.37	-7.42	1,886,779.89	1,245,331.48	36.17799296	-107.58870650	
1,300.00	9.00	314.797	1,298.77	16.57	-16.69	1,886,789.08	1,245,322.22	36.17801787	-107.58873830	
1,400.00	12.00	314.797	1,397.08	29.41	-29.62	1,886,801.92	1,245,309.29	36.17805264	-107.58878270	
1,423.06	12.69	314.797	1,419.61	32.88	-33.11	1,886,805.40	1,245,305.79	36.17806205	-107.58879472	
<b>Pictured Cliffs</b>										
1,499.76	14.99	314.797	1,494.07	45.81	-46.13	1,886,818.32	1,245,292.77	36.17809706	-107.58883943	
<b>Begin 14.99° tangent</b>										
1,587.95	14.99	314.797	1,579.27	61.88	-62.33	1,886,834.40	1,245,276.58	36.17814060	-107.58889503	
<b>Lewis</b>										
1,600.00	14.99	314.797	1,590.90	64.08	-64.54	1,886,836.60	1,245,274.37	36.17814654	-107.58890262	
1,700.00	14.99	314.797	1,687.50	82.31	-82.89	1,886,854.82	1,245,256.01	36.17819591	-107.58896566	
1,800.00	14.99	314.797	1,784.10	100.54	-101.25	1,886,873.05	1,245,237.66	36.17824527	-107.58902870	
1,835.85	14.99	314.797	1,818.73	107.07	-107.83	1,886,879.59	1,245,231.07	36.17826297	-107.58905130	
<b>Chacra_A</b>										
1,900.00	14.99	314.797	1,880.69	118.76	-119.61	1,886,891.28	1,245,219.30	36.17829464	-107.58909174	
2,000.00	14.99	314.797	1,977.29	136.99	-137.97	1,886,909.51	1,245,200.94	36.17834400	-107.58915478	
2,100.00	14.99	314.797	2,073.88	155.22	-156.32	1,886,927.73	1,245,182.58	36.17839337	-107.58921782	
2,200.00	14.99	314.797	2,170.48	173.45	-174.68	1,886,945.96	1,245,164.23	36.17844273	-107.58928086	
2,300.00	14.99	314.797	2,267.07	191.67	-193.04	1,886,964.19	1,245,145.87	36.17849210	-107.58934390	
2,400.00	14.99	314.797	2,363.67	209.90	-211.40	1,886,982.42	1,245,127.51	36.17854146	-107.58940694	
2,500.00	14.99	314.797	2,460.27	228.13	-229.75	1,887,000.64	1,245,109.15	36.17859082	-107.58946998	
2,600.00	14.99	314.797	2,556.86	246.36	-248.11	1,887,018.87	1,245,090.80	36.17864019	-107.58953302	
2,700.00	14.99	314.797	2,653.46	264.58	-266.47	1,887,037.10	1,245,072.44	36.17868955	-107.58959605	
2,800.00	14.99	314.797	2,750.05	282.81	-284.83	1,887,055.33	1,245,054.08	36.17873892	-107.58965909	
2,900.00	14.99	314.797	2,846.65	301.04	-303.18	1,887,073.55	1,245,035.72	36.17878828	-107.58972213	
2,946.25	14.99	314.797	2,891.33	309.47	-311.67	1,887,081.98	1,245,027.23	36.17881111	-107.58975129	
<b>Cliff House_Basal</b>										
2,977.24	14.99	314.797	2,921.26	315.12	-317.36	1,887,087.63	1,245,021.55	36.17882641	-107.58977083	
<b>Menefee</b>										
3,000.00	14.99	314.797	2,943.25	319.27	-321.54	1,887,091.78	1,245,017.37	36.17883764	-107.58978517	
3,100.00	14.99	314.797	3,039.84	337.49	-339.90	1,887,110.01	1,244,999.01	36.17888701	-107.58984821	
3,200.00	14.99	314.797	3,136.44	355.72	-358.26	1,887,128.24	1,244,980.65	36.17893637	-107.58991126	



Planning Report - Geographic

<b>Database:</b>	DT-Jun1425_v17	<b>Local Co-ordinate Reference:</b>	Site North Alamito Unit (560, 562 & 563)
<b>Company:</b>	Enduring Resources LLC	<b>TVD Reference:</b>	RKB=6876+23.5 @ 6899.50ft
<b>Project:</b>	Sandoval County, New Mexico NAD83 NM C	<b>MD Reference:</b>	RKB=6876+23.5 @ 6899.50ft
<b>Site:</b>	North Alamito Unit (560, 562 & 563)	<b>North Reference:</b>	Grid
<b>Well:</b>	North Alamito Unit 560H	<b>Survey Calculation Method:</b>	Minimum Curvature
<b>Wellbore:</b>	Original Hole		
<b>Design:</b>	rev0		

Planned Survey										
Measured Depth (ft)	Inclination (°)	Azimuth (°)	Vertical Depth (ft)	+N/-S (ft)	+E/-W (ft)	Map Northing (usft)	Map Easting (usft)	Latitude	Longitude	
3,300.00	14.99	314.797	3,233.03	373.95	-376.61	1,887,146.46	1,244,962.30	36.17898574	-107.58997430	
3,400.00	14.99	314.797	3,329.63	392.18	-394.97	1,887,164.69	1,244,943.94	36.17903510	-107.59003734	
3,500.00	14.99	314.797	3,426.23	410.40	-413.33	1,887,182.92	1,244,925.58	36.17908446	-107.59010038	
3,600.00	14.99	314.797	3,522.82	428.63	-431.69	1,887,201.15	1,244,907.22	36.17913383	-107.59016342	
3,700.00	14.99	314.797	3,619.42	446.86	-450.04	1,887,219.37	1,244,888.87	36.17918319	-107.59022646	
3,800.00	14.99	314.797	3,716.01	465.09	-468.40	1,887,237.60	1,244,870.51	36.17923256	-107.59028950	
3,900.00	14.99	314.797	3,812.61	483.31	-486.76	1,887,255.83	1,244,852.15	36.17928192	-107.59035254	
3,901.71	14.99	314.797	3,814.26	483.63	-487.07	1,887,256.14	1,244,851.84	36.17928276	-107.59035362	
<b>Point Lookout</b>										
3,914.42	14.99	314.797	3,826.54	485.94	-489.41	1,887,258.46	1,244,849.50	36.17928904	-107.59036163	
<b>Begin 3°/100' drop</b>										
4,000.00	12.43	314.797	3,909.67	500.23	-503.80	1,887,272.75	1,244,835.11	36.17932774	-107.59041105	
4,100.00	9.43	314.797	4,007.85	513.58	-517.24	1,887,286.10	1,244,821.67	36.17936390	-107.59045723	
4,111.19	9.09	314.797	4,018.89	514.85	-518.52	1,887,287.37	1,244,820.39	36.17936733	-107.59046161	
<b>Mancos</b>										
4,200.00	6.43	314.797	4,106.88	523.30	-527.03	1,887,295.81	1,244,811.88	36.17939020	-107.59049083	
4,300.00	3.43	314.797	4,206.50	529.35	-533.12	1,887,301.86	1,244,805.79	36.17940658	-107.59051174	
4,400.00	0.43	314.797	4,306.43	531.71	-535.50	1,887,304.23	1,244,803.41	36.17941299	-107.59051993	
4,414.18	0.00	0.000	4,320.61	531.75	-535.54	1,887,304.27	1,244,803.37	36.17941309	-107.59052006	
<b>Begin vertical hold</b>										
4,422.26	0.00	0.000	4,328.69	531.75	-535.54	1,887,304.27	1,244,803.37	36.17941309	-107.59052006	
<b>MNCS_A</b>										
4,500.00	0.00	0.000	4,406.43	531.75	-535.54	1,887,304.27	1,244,803.37	36.17941309	-107.59052006	
4,527.26	0.00	0.000	4,433.69	531.75	-535.54	1,887,304.27	1,244,803.37	36.17941309	-107.59052006	
<b>MNCS_B</b>										
4,600.00	0.00	0.000	4,506.43	531.75	-535.54	1,887,304.27	1,244,803.37	36.17941309	-107.59052006	
4,614.18	0.00	0.000	4,520.61	531.75	-535.54	1,887,304.27	1,244,803.37	36.17941309	-107.59052006	
<b>Begin 10°/100' build</b>										
4,617.26	0.31	100.470	4,523.69	531.75	-535.53	1,887,304.26	1,244,803.38	36.17941309	-107.59052003	
<b>MNCS_C</b>										
4,650.00	3.58	100.470	4,556.41	531.55	-534.44	1,887,304.06	1,244,804.47	36.17941258	-107.59051632	
4,657.31	4.31	100.470	4,563.71	531.46	-533.94	1,887,303.97	1,244,804.97	36.17941235	-107.59051464	
<b>MNCS_Cms</b>										
4,700.00	8.58	100.470	4,606.11	530.58	-529.23	1,887,303.10	1,244,809.68	36.17941013	-107.59049863	
4,750.00	13.58	100.470	4,655.17	528.84	-519.78	1,887,301.35	1,244,819.13	36.17940570	-107.59046654	
4,790.29	17.61	100.470	4,693.96	526.87	-509.13	1,887,299.39	1,244,829.78	36.17940069	-107.59043037	
<b>MNCS_D</b>										
4,800.00	18.58	100.470	4,703.19	526.32	-506.17	1,887,298.84	1,244,832.74	36.17939930	-107.59042030	
4,850.00	23.58	100.470	4,749.83	523.05	-488.49	1,887,295.57	1,244,850.42	36.17939100	-107.59036025	
4,900.00	28.58	100.470	4,794.73	519.06	-466.88	1,887,291.58	1,244,872.03	36.17938085	-107.59028686	
4,934.58	32.04	100.470	4,824.57	515.89	-449.72	1,887,288.41	1,244,889.19	36.17937279	-107.59022858	
<b>MNCS_E</b>										
4,950.00	33.58	100.470	4,837.53	514.37	-441.50	1,887,286.89	1,244,897.41	36.17936893	-107.59020068	
5,000.00	38.58	100.470	4,877.93	509.02	-412.55	1,887,281.54	1,244,926.36	36.17935534	-107.59010236	
5,009.10	39.49	100.470	4,885.00	507.98	-406.91	1,887,280.50	1,244,931.99	36.17935269	-107.59008321	
<b>MNCS_F</b>										
5,050.00	43.58	100.470	4,915.61	503.05	-380.25	1,887,275.57	1,244,958.66	36.17934017	-107.58999266	
5,100.00	48.58	100.470	4,950.28	496.51	-344.85	1,887,269.03	1,244,994.06	36.17932355	-107.58987241	
5,108.29	49.41	100.470	4,955.72	495.37	-338.69	1,887,267.89	1,245,000.22	36.17932066	-107.58985151	
<b>MNCS_G</b>										
5,150.00	53.58	100.470	4,981.68	489.44	-306.60	1,887,261.96	1,245,032.30	36.17930559	-107.58974253	
5,200.00	58.58	100.470	5,009.57	481.91	-265.82	1,887,254.42	1,245,073.09	36.17928643	-107.58960401	



Planning Report - Geographic

<b>Database:</b>	DT-Jun1425_v17	<b>Local Co-ordinate Reference:</b>	Site North Alamito Unit (560, 562 & 563)
<b>Company:</b>	Enduring Resources LLC	<b>TVD Reference:</b>	RKB=6876+23.5 @ 6899.50ft
<b>Project:</b>	Sandoval County, New Mexico NAD83 NM C	<b>MD Reference:</b>	RKB=6876+23.5 @ 6899.50ft
<b>Site:</b>	North Alamito Unit (560, 562 & 563)	<b>North Reference:</b>	Grid
<b>Well:</b>	North Alamito Unit 560H	<b>Survey Calculation Method:</b>	Minimum Curvature
<b>Wellbore:</b>	Original Hole		
<b>Design:</b>	rev0		

Planned Survey										
Measured Depth (ft)	Inclination (°)	Azimuth (°)	Vertical Depth (ft)	+N/-S (ft)	+E/-W (ft)	Map Northing (usft)	Map Easting (usft)	Latitude	Longitude	
5,213.74	59.96	100.470	5,016.59	479.76	-254.20	1,887,252.28	1,245,084.70	36.17928098	-107.58956457	
<b>MNCS_H</b>										
5,250.00	63.58	100.470	5,033.74	473.96	-222.79	1,887,246.47	1,245,116.12	36.17926623	-107.58945789	
5,300.00	68.58	100.470	5,054.00	465.65	-177.86	1,887,238.17	1,245,161.05	36.17924513	-107.58930529	
5,350.00	73.58	100.470	5,070.21	457.06	-131.36	1,887,229.57	1,245,207.54	36.17922329	-107.58914737	
5,360.00	74.58	100.470	5,072.95	455.31	-121.91	1,887,227.83	1,245,217.00	36.17921885	-107.58911526	
<b>MNCS_I</b>										
5,400.00	78.58	100.470	5,082.23	448.24	-83.66	1,887,220.76	1,245,255.25	36.17920088	-107.58898534	
5,450.00	83.58	100.470	5,089.98	439.27	-35.10	1,887,211.78	1,245,303.81	36.17917808	-107.58882043	
5,464.18	85.00	100.470	5,091.39	436.71	-21.23	1,887,209.22	1,245,317.68	36.17917157	-107.58877332	
<b>Casing @ 5464.18 MD 5091.39 TVD</b>										
5,471.00	85.68	100.470	5,091.94	435.47	-14.54	1,887,207.99	1,245,324.37	36.17916843	-107.58875061	
<b>7" Intermediate Casing</b>										
5,500.00	88.58	100.470	5,093.39	430.21	13.94	1,887,202.72	1,245,352.85	36.17915505	-107.58865389	
5,508.42	89.42	100.470	5,093.54	428.68	22.21	1,887,201.19	1,245,361.12	36.17915116	-107.58862578	
<b>Begin 89.42° lateral</b>										
5,600.00	89.42	100.470	5,094.46	412.04	112.27	1,887,184.55	1,245,451.18	36.17910887	-107.58831994	
5,700.00	89.42	100.470	5,095.47	393.87	210.60	1,887,166.38	1,245,549.51	36.17906269	-107.58798598	
5,800.00	89.42	100.470	5,096.47	375.70	308.93	1,887,148.21	1,245,647.84	36.17901651	-107.58765203	
5,900.00	89.42	100.470	5,097.48	357.52	407.26	1,887,130.04	1,245,746.17	36.17897033	-107.58731808	
6,000.00	89.42	100.470	5,098.48	339.35	505.59	1,887,111.87	1,245,844.50	36.17892414	-107.58698413	
6,100.00	89.42	100.470	5,099.49	321.18	603.92	1,887,093.70	1,245,942.83	36.17887796	-107.58665018	
6,200.00	89.42	100.470	5,100.49	303.01	702.25	1,887,075.53	1,246,041.16	36.17883177	-107.58631623	
6,300.00	89.42	100.470	5,101.50	284.84	800.58	1,887,057.36	1,246,139.49	36.17878559	-107.58598228	
6,400.00	89.42	100.470	5,102.50	266.67	898.91	1,887,039.19	1,246,237.82	36.17873940	-107.58564833	
6,500.00	89.42	100.470	5,103.51	248.50	997.24	1,887,021.01	1,246,336.15	36.17869321	-107.58531438	
6,600.00	89.42	100.470	5,104.51	230.33	1,095.57	1,887,002.84	1,246,434.48	36.17864702	-107.58498043	
6,700.00	89.42	100.470	5,105.52	212.16	1,193.90	1,886,984.67	1,246,532.81	36.17860083	-107.58464648	
6,800.00	89.42	100.470	5,106.52	193.99	1,292.23	1,886,966.50	1,246,631.14	36.17855464	-107.58431253	
6,900.00	89.42	100.470	5,107.53	175.82	1,390.56	1,886,948.33	1,246,729.47	36.17850845	-107.58397858	
7,000.00	89.42	100.470	5,108.53	157.64	1,488.89	1,886,930.16	1,246,827.80	36.17846226	-107.58364463	
7,100.00	89.42	100.470	5,109.54	139.47	1,587.22	1,886,911.99	1,246,926.13	36.17841606	-107.58331069	
7,200.00	89.42	100.470	5,110.55	121.30	1,685.55	1,886,893.82	1,247,024.46	36.17836987	-107.58297674	
7,300.00	89.42	100.470	5,111.55	103.13	1,783.88	1,886,875.65	1,247,122.78	36.17832367	-107.58264279	
7,400.00	89.42	100.470	5,112.56	84.96	1,882.21	1,886,857.48	1,247,221.11	36.17827747	-107.58230884	
7,500.00	89.42	100.470	5,113.56	66.79	1,980.54	1,886,839.31	1,247,319.44	36.17823128	-107.58197490	
7,600.00	89.42	100.470	5,114.57	48.62	2,078.87	1,886,821.13	1,247,417.77	36.17818508	-107.58164095	
7,700.00	89.42	100.470	5,115.57	30.45	2,177.20	1,886,802.96	1,247,516.10	36.17813888	-107.58130701	
7,800.00	89.42	100.470	5,116.58	12.28	2,275.53	1,886,784.79	1,247,614.43	36.17809268	-107.58097306	
7,900.00	89.42	100.470	5,117.58	-5.89	2,373.86	1,886,766.62	1,247,712.76	36.17804648	-107.58063912	
8,000.00	89.42	100.470	5,118.59	-24.06	2,472.19	1,886,748.45	1,247,811.09	36.17800027	-107.58030517	
8,100.00	89.42	100.470	5,119.59	-42.24	2,570.52	1,886,730.28	1,247,909.42	36.17795407	-107.57997123	
8,200.00	89.42	100.470	5,120.60	-60.41	2,668.85	1,886,712.11	1,248,007.75	36.17790787	-107.57963729	
8,300.00	89.42	100.470	5,121.60	-78.58	2,767.18	1,886,693.94	1,248,106.08	36.17786166	-107.57930334	
8,400.00	89.42	100.470	5,122.61	-96.75	2,865.51	1,886,675.77	1,248,204.41	36.17781546	-107.57896940	
8,500.00	89.42	100.470	5,123.61	-114.92	2,963.84	1,886,657.60	1,248,302.74	36.17776925	-107.57863546	
8,600.00	89.42	100.470	5,124.62	-133.09	3,062.17	1,886,639.43	1,248,401.07	36.17772304	-107.57830152	
8,700.00	89.42	100.470	5,125.63	-151.26	3,160.50	1,886,621.26	1,248,499.40	36.17767683	-107.57796757	
8,800.00	89.42	100.470	5,126.63	-169.43	3,258.83	1,886,603.08	1,248,597.73	36.17763062	-107.57763363	
8,900.00	89.42	100.470	5,127.64	-187.60	3,357.16	1,886,584.91	1,248,696.06	36.17758441	-107.57729969	
9,000.00	89.42	100.470	5,128.64	-205.77	3,455.49	1,886,566.74	1,248,794.39	36.17753820	-107.57696575	
9,100.00	89.42	100.470	5,129.65	-223.94	3,553.82	1,886,548.57	1,248,892.72	36.17749199	-107.57663181	
9,200.00	89.42	100.470	5,130.65	-242.12	3,652.15	1,886,530.40	1,248,991.05	36.17744577	-107.57629787	
9,300.00	89.42	100.470	5,131.66	-260.29	3,750.48	1,886,512.23	1,249,089.38	36.17739956	-107.57596393	



Planning Report - Geographic

<b>Database:</b>	DT-Jun1425_v17	<b>Local Co-ordinate Reference:</b>	Site North Alamito Unit (560, 562 & 563)
<b>Company:</b>	Enduring Resources LLC	<b>TVD Reference:</b>	RKB=6876+23.5 @ 6899.50ft
<b>Project:</b>	Sandoval County, New Mexico NAD83 NM C	<b>MD Reference:</b>	RKB=6876+23.5 @ 6899.50ft
<b>Site:</b>	North Alamito Unit (560, 562 & 563)	<b>North Reference:</b>	Grid
<b>Well:</b>	North Alamito Unit 560H	<b>Survey Calculation Method:</b>	Minimum Curvature
<b>Wellbore:</b>	Original Hole		
<b>Design:</b>	rev0		

Planned Survey										
Measured Depth (ft)	Inclination (°)	Azimuth (°)	Vertical Depth (ft)	+N/-S (ft)	+E/-W (ft)	Map Northing (usft)	Map Easting (usft)	Latitude	Longitude	
9,400.00	89.42	100.470	5,132.66	-278.46	3,848.81	1,886,494.06	1,249,187.71	36.17735334	-107.57562999	
9,500.00	89.42	100.470	5,133.67	-296.63	3,947.14	1,886,475.89	1,249,286.04	36.17730713	-107.57529605	
9,600.00	89.42	100.470	5,134.67	-314.80	4,045.47	1,886,457.72	1,249,384.37	36.17726091	-107.57496212	
9,700.00	89.42	100.470	5,135.68	-332.97	4,143.80	1,886,439.55	1,249,482.70	36.17721469	-107.57462818	
9,800.00	89.42	100.470	5,136.68	-351.14	4,242.13	1,886,421.38	1,249,581.03	36.17716847	-107.57429424	
9,900.00	89.42	100.470	5,137.69	-369.31	4,340.46	1,886,403.21	1,249,679.36	36.17712225	-107.57396030	
10,000.00	89.42	100.470	5,138.69	-387.48	4,438.79	1,886,385.03	1,249,777.69	36.17707603	-107.57362637	
10,030.35	89.42	100.470	5,139.00	-393.00	4,468.64	1,886,379.52	1,249,807.54	36.17706200	-107.57352500	
<b>PBHL/TD @ 10030.35 MD 5139.00 TVD</b>										

Design Targets										
Target Name	Dip Angle (°)	Dip Dir. (°)	TVD (ft)	+N/-S (ft)	+E/-W (ft)	Northing (usft)	Easting (usft)	Latitude	Longitude	
North Alamito 560 vs=0 - hit/miss target - Shape - Point	0.00	0.000	5,094.00	418.49	77.34	1,887,191.01	1,245,416.25	36.17912527	-107.58843856	
- plan misses target center by 0.10ft at 5564.48ft MD (5094.10 TVD, 418.49 N, 77.34 E)										
North Alamito 560 FTP 1 - plan misses target center by 32.99ft at 5325.52ft MD (5062.79 TVD, 461.30 N, -154.30 E) - Point	0.00	0.000	5,094.00	463.24	-164.82	1,887,235.76	1,245,174.09	36.17923900	-107.58926100	
North Alamito 560 LTP 4 - plan hits target center - Point	0.00	0.000	5,139.00	-393.00	4,468.64	1,886,379.52	1,249,807.54	36.17706200	-107.57352500	

Casing Points					
Measured Depth (ft)	Vertical Depth (ft)	Name	Casing Diameter (")	Hole Diameter (")	
350.00	350.00	9-5/8" Surface Casing	9-5/8	12-1/4	
5,471.00	5,091.94	7" Intermediate Casing	7	8-3/4	



Planning Report - Geographic

<b>Database:</b>	DT-Jun1425_v17	<b>Local Co-ordinate Reference:</b>	Site North Alamito Unit (560, 562 & 563)
<b>Company:</b>	Enduring Resources LLC	<b>TVD Reference:</b>	RKB=6876+23.5 @ 6899.50ft
<b>Project:</b>	Sandoval County, New Mexico NAD83 NM C	<b>MD Reference:</b>	RKB=6876+23.5 @ 6899.50ft
<b>Site:</b>	North Alamito Unit (560, 562 & 563)	<b>North Reference:</b>	Grid
<b>Well:</b>	North Alamito Unit 560H	<b>Survey Calculation Method:</b>	Minimum Curvature
<b>Wellbore:</b>	Original Hole		
<b>Design:</b>	rev0		

Formations					
Measured Depth (ft)	Vertical Depth (ft)	Name	Lithology	Dip (°)	Dip Direction (°)
880.00	880.00	Ojo Alamo		0.580	100.470
920.00	920.00	Kirtland		0.580	100.470
1,110.03	1,109.97	Fruitland		0.580	100.470
1,423.06	1,419.61	Pictured Cliffs		0.580	100.470
1,587.95	1,579.27	Lewis		0.580	100.470
1,835.85	1,818.73	Chacra_A		0.580	100.470
2,946.25	2,891.33	Cliff House_Basal		0.580	100.470
2,977.24	2,921.26	Menefee		0.580	100.470
3,901.71	3,814.26	Point Lookout		0.580	100.470
4,111.19	4,018.89	Mancos		0.580	100.470
4,422.26	4,328.69	MNCS_A		0.580	100.470
4,527.26	4,433.69	MNCS_B		0.580	100.470
4,617.26	4,523.69	MNCS_C		0.580	100.470
4,657.31	4,563.71	MNCS_Cms		0.580	100.470
4,790.29	4,693.96	MNCS_D		0.580	100.470
4,934.58	4,824.57	MNCS_E		0.580	100.470
5,009.10	4,885.00	MNCS_F		0.000	100.470
5,108.29	4,955.72	MNCS_G		0.580	100.470
5,213.74	5,016.59	MNCS_H		0.580	100.470
5,360.00	5,072.95	MNCS_I		0.580	100.470

Plan Annotations					
Measured Depth (ft)	Vertical Depth (ft)	Local Coordinates		Comment	
		+N/-S (ft)	+E/-W (ft)		
1,000.00	1,000.00	0.00	0.00	KOP Begin 3°/100' build	
1,499.76	1,494.07	45.81	-46.13	Begin 14.99° tangent	
3,914.42	3,826.54	485.94	-489.41	Begin 3°/100' drop	
4,414.18	4,320.61	531.75	-535.54	Begin vertical hold	
4,614.18	4,520.61	531.75	-535.54	Begin 10°/100' build	
5,464.18	5,091.39	436.71	-21.23	Casing @ 5464.18 MD 5091.39 TVD	
5,508.42	5,093.54	428.68	22.21	Begin 89.42° lateral	
10,030.35	5,139.00	-393.00	4,468.64	PBHL/TD @ 10030.35 MD 5139.00 TVD	



Anticollision Report

<b>Company:</b>	Enduring Resources LLC	<b>Local Co-ordinate Reference:</b>	Well North Alamito Unit 560H
<b>Project:</b>	Sandoval County, New Mexico NAD83 NM C	<b>TVD Reference:</b>	RKB=6876+23.5 @ 6899.50ft
<b>Reference Site:</b>	Sec 33 T23N R07W North Alamito Unit 560 562 563	<b>MD Reference:</b>	RKB=6876+23.5 @ 6899.50ft
<b>Site Error:</b>	0.00 ft	<b>North Reference:</b>	Grid
<b>Reference Well:</b>	North Alamito Unit 560H	<b>Survey Calculation Method:</b>	Minimum Curvature
<b>Well Error:</b>	0.00 ft	<b>Output errors are at</b>	2.00 sigma
<b>Reference Wellbore</b>	Original Hole	<b>Database:</b>	DT-Oct0825v17
<b>Reference Design:</b>	rev0	<b>Offset TVD Reference:</b>	Offset Datum

<b>Reference</b>	rev0		
<b>Filter type:</b>	GLOBAL FILTER APPLIED: All wellpaths within 200'+ 100/1000 of reference		
<b>Interpolation Method:</b>	MD Interval 100.00ft	<b>Error Model:</b>	ISCWSA
<b>Depth Range:</b>	Unlimited	<b>Scan Method:</b>	Closest Approach 3D
<b>Results Limited by:</b>	Maximum centre distance of 1,203.04ft	<b>Error Surface:</b>	Ellipsoid Separation
<b>Warning Levels Evaluated at:</b>	2.00 Sigma	<b>Casing Method:</b>	Not applied

<b>Survey Tool Program</b>	<b>Date</b>	12/10/2025		
<b>From (ft)</b>	<b>To (ft)</b>	<b>Survey (Wellbore)</b>	<b>Tool Name</b>	<b>Description</b>
0.00	10,030.35	rev0 (Original Hole)	MWD	OWSG MWD - Standard

Site Name	Reference Measured Depth (ft)	Offset Measured Depth (ft)	Distance		Separation Factor	Warning
			Between Centres (ft)	Between Ellipses (ft)		
<b>Sec 32 T23N R07W</b>						
N Alamito Unit #328H (Lybrook P32-2307 01H) - Orig hol	723.32	715.86	94.86	90.84	23.597	CC, ES
N Alamito Unit #328H (Lybrook P32-2307 01H) - Orig hol	5,093.62	5,103.08	373.31	334.66	9.658	SF
<b>Sec 33 T23N R07W North Alamito Unit 560 562 563</b>						
Federal I #003 - Orig hole - Inc only surveys	6,281.69	5,060.83	69.51	-116.63	0.373	Level 3<2.00, CC, SF
Federal I #003 - Orig hole - Inc only surveys	6,300.00	5,061.03	71.88	-116.83	0.381	Level 3<2.00, ES
N Alamito Unit #323H (- Orig hole - MWD surveys	5,095.24	5,326.90	607.31	565.97	14.693	CC, ES
N Alamito Unit #323H (- Orig hole - MWD surveys	5,100.00	5,324.87	607.33	565.99	14.692	SF
North Alamito Unit 562H - Original Hole - rev0	1,000.00	1,000.00	20.06	13.06	2.865	CC, ES
North Alamito Unit 562H - Original Hole - rev0	1,100.00	1,099.95	21.85	14.14	2.832	SF
North Alamito Unit 563H - Original Hole - rev0	1,000.00	1,000.00	40.12	33.12	5.730	CC, ES
North Alamito Unit 563H - Original Hole - rev0	1,100.00	1,098.12	43.98	36.29	5.719	SF
<b>Sec 34 T23N R07W</b>						
N Alamito Unit #306H - Orig Hole - MWD surveys	10,030.35	5,928.37	469.06	342.04	3.693	CC, ES, SF

<b>Offset Design:</b>	Sec 32 T23N R07W - N Alamito Unit #328H (Lybrook P32-2307 01H) - Orig hole - MWD surveys										<b>Offset Site Error:</b>	0.00 ft
<b>Survey Program:</b>	570-MWD										<b>Offset Well Error:</b>	0.00 ft
Reference Measured Depth (ft)	Vertical Depth (ft)	Offset Measured Depth (ft)	Vertical Depth (ft)	Semi Major Axis			Offset Wellbore Centre		Rule Assigned:			Warning
				Reference (ft)	Offset (ft)	Highside Toolface (°)	+N/-S (ft)	+E/-W (ft)	Between Centres (ft)	Between Ellipses (ft)	Minimum Separation (ft)	
0.00	0.00	0.00	0.00	0.00	0.00	-148.752	-84.13	-51.05	98.70			
100.00	100.00	92.65	92.65	0.27	0.16	-148.697	-84.02	-51.09	98.34	97.90	0.44	225.892
200.00	200.00	192.81	192.81	0.63	0.34	-148.513	-83.66	-51.24	98.10	97.14	0.97	101.353
300.00	300.00	292.97	292.97	0.99	0.51	-148.197	-83.04	-51.49	97.71	96.21	1.50	65.115
400.00	400.00	393.12	393.11	1.35	0.68	-147.746	-82.16	-51.85	97.15	95.12	2.03	47.785
500.00	500.00	493.27	493.25	1.71	0.86	-147.156	-81.03	-52.31	96.44	93.88	2.57	37.590
600.00	600.00	593.30	593.27	2.07	1.07	-146.418	-79.64	-52.88	95.60	92.46	3.14	30.436
700.00	700.00	693.10	693.06	2.43	1.43	-145.468	-78.21	-53.82	94.94	91.08	3.86	24.609
723.32	723.32	715.86	715.82	2.51	1.51	-145.288	-77.97	-54.02	94.86	90.84	4.02	23.597 CC, ES
800.00	800.00	790.98	790.93	2.78	1.76	-145.588	-78.89	-54.04	95.64	91.09	4.55	21.034
900.00	900.00	890.60	890.50	3.14	2.10	-146.914	-81.73	-53.25	97.56	92.33	5.24	18.630
1,000.00	1,000.00	990.61	990.47	3.50	2.44	-148.016	-84.41	-52.71	99.54	93.60	5.94	16.767

CC - Min centre to center distance or convergent point, SF - min separation factor, ES - min ellipse separation



Anticollision Report

<b>Company:</b>	Enduring Resources LLC	<b>Local Co-ordinate Reference:</b>	Well North Alamito Unit 560H
<b>Project:</b>	Sandoval County, New Mexico NAD83 NM C	<b>TVD Reference:</b>	RKB=6876+23.5 @ 6899.50ft
<b>Reference Site:</b>	Sec 33 T23N R07W North Alamito Unit 560 562 563	<b>MD Reference:</b>	RKB=6876+23.5 @ 6899.50ft
<b>Site Error:</b>	0.00 ft	<b>North Reference:</b>	Grid
<b>Reference Well:</b>	North Alamito Unit 560H	<b>Survey Calculation Method:</b>	Minimum Curvature
<b>Well Error:</b>	0.00 ft	<b>Output errors are at</b>	2.00 sigma
<b>Reference Wellbore</b>	Original Hole	<b>Database:</b>	DT-Oct0825v17
<b>Reference Design:</b>	rev0	<b>Offset TVD Reference:</b>	Offset Datum

Offset Design: Sec 32 T23N R07W - N Alamito Unit #328H (Lybrook P32-2307 01H) - Orig hole - MWD surveys													Offset Site Error:	0.00 ft
Survey Program: 570-MWD													Offset Well Error:	0.00 ft
Reference		Offset		Semi Major Axis			Offset Wellbore Centre		Distance		Rule Assigned:		Warning	
Measured Depth (ft)	Vertical Depth (ft)	Measured Depth (ft)	Vertical Depth (ft)	Reference (ft)	Offset (ft)	Highside Toolface (°)	+N/-S (ft)	+E/-W (ft)	Between Centres (ft)	Between Ellipses (ft)	Minimum Separation (ft)	Separation Factor		
1,100.00	1,099.95	1,090.88	1,090.72	3.86	2.78	-105.209	-86.98	-52.15	102.09	95.45	6.64	15.375		
1,200.00	1,199.63	1,190.75	1,190.55	4.22	3.13	-110.172	-89.28	-51.35	106.18	98.83	7.35	14.454		
1,300.00	1,298.77	1,291.03	1,290.81	4.58	3.49	-117.051	-90.92	-50.42	112.65	104.59	8.06	13.972		
1,400.00	1,397.08	1,391.69	1,391.47	4.96	3.84	-124.695	-90.17	-49.97	121.31	112.52	8.79	13.804		
1,500.00	1,494.31	1,489.14	1,488.91	5.37	4.17	-132.481	-88.66	-49.70	134.58	125.06	9.51	14.144		
1,600.00	1,590.90	1,586.02	1,585.77	5.81	4.51	-139.572	-87.16	-49.71	151.98	141.74	10.24	14.843		
1,700.00	1,687.50	1,682.64	1,682.38	6.27	4.85	-145.098	-85.77	-49.90	171.30	160.35	10.96	15.636		
1,800.00	1,784.10	1,780.20	1,779.93	6.74	5.19	-149.383	-84.41	-50.60	191.79	180.11	11.67	16.428		
1,900.00	1,880.69	1,877.11	1,876.82	7.22	5.54	-152.491	-83.22	-52.49	212.88	200.49	12.39	17.181		
2,000.00	1,977.29	1,975.79	1,975.46	7.72	5.88	-154.903	-82.26	-55.09	234.46	221.35	13.12	17.876		
2,100.00	2,073.88	2,073.63	2,073.19	8.22	6.23	-156.656	-80.23	-59.21	254.78	240.94	13.84	18.407		
2,200.00	2,170.48	2,157.60	2,157.11	8.73	6.52	-158.018	-80.83	-61.37	278.44	263.96	14.48	19.225		
2,300.00	2,267.07	2,253.53	2,253.00	9.25	6.85	-159.566	-83.89	-61.48	305.43	290.24	15.19	20.112		
2,400.00	2,363.67	2,357.89	2,357.30	9.77	7.21	-161.800	-83.08	-58.44	330.51	314.57	15.93	20.742		
2,500.00	2,460.27	2,453.67	2,453.06	10.29	7.55	-163.232	-82.43	-57.81	354.98	338.35	16.64	21.336		
2,600.00	2,556.86	2,531.00	2,530.36	10.82	7.82	-163.940	-84.14	-58.31	381.60	364.39	17.21	22.171		
2,700.00	2,653.46	2,624.36	2,623.55	11.35	8.14	-164.962	-88.73	-55.30	412.22	394.33	17.89	23.038		
2,800.00	2,750.05	2,744.53	2,743.66	11.89	8.56	-166.317	-89.66	-52.44	439.02	420.25	18.77	23.386		
2,900.00	2,846.65	2,840.48	2,839.59	12.42	8.89	-167.312	-88.60	-50.82	464.22	444.74	19.48	23.832		
3,000.00	2,943.25	2,935.73	2,934.81	12.96	9.23	-168.209	-87.55	-49.11	489.61	469.43	20.18	24.260		
3,100.00	3,039.84	3,032.71	3,031.78	13.50	9.57	-169.024	-86.58	-47.40	515.17	494.27	20.90	24.651		
3,200.00	3,136.44	3,130.33	3,129.38	14.04	9.91	-169.712	-85.72	-46.20	540.59	518.97	21.62	25.003		
3,300.00	3,233.03	3,213.02	3,211.47	14.58	10.21	-171.070	-81.09	-38.30	567.19	544.97	22.22	25.521		
3,400.00	3,329.63	3,318.54	3,314.20	15.13	10.58	-173.856	-68.85	-17.78	595.72	572.75	22.97	25.933		
3,500.00	3,426.23	3,469.48	3,459.93	15.67	11.14	-177.854	-40.37	8.40	618.66	594.67	23.99	25.787		
3,600.00	3,522.82	3,570.63	3,559.94	16.22	11.51	-179.119	-26.38	12.90	637.72	612.97	24.75	25.768		
3,700.00	3,619.42	3,659.62	3,648.72	16.76	11.83	-179.295	-21.35	10.27	657.62	632.18	25.44	25.851		
3,800.00	3,716.01	3,756.46	3,745.40	17.31	12.16	-179.175	-18.78	5.35	678.18	652.02	26.16	25.923		
3,900.00	3,812.61	3,859.34	3,848.10	17.86	12.52	-179.230	-14.20	1.26	698.23	671.32	26.92	25.940		
4,000.00	3,909.67	3,959.15	3,947.71	18.39	12.87	-179.367	-8.95	-2.08	716.29	688.63	27.66	25.900		
4,100.00	4,007.85	4,077.83	4,066.00	18.86	13.29	-179.597	-0.52	-6.72	727.49	699.02	28.47	25.553		
4,200.00	4,106.88	4,172.58	4,160.37	19.27	13.62	-179.783	6.81	-10.79	732.79	703.62	29.17	25.122		
4,300.00	4,206.50	4,282.78	4,270.12	19.63	14.01	-179.848	14.37	-17.22	732.40	702.48	29.92	24.479		
4,400.00	4,306.43	4,633.13	4,601.26	19.94	15.29	-177.095	60.19	-106.63	705.45	675.50	29.96	23.550		
4,500.00	4,406.43	4,771.14	4,718.15	20.21	15.94	141.873	76.30	-178.07	661.15	630.95	30.20	21.892		
4,600.00	4,506.43	4,994.17	4,879.69	20.49	17.47	153.365	113.49	-325.77	603.26	573.83	29.43	20.500		
4,700.00	4,606.11	5,117.63	4,943.85	20.72	18.73	72.563	132.39	-429.21	536.42	505.72	30.70	17.472		
4,800.00	4,703.19	5,137.80	4,952.23	20.86	18.97	83.827	135.17	-447.35	471.45	438.10	33.35	14.135		
4,900.00	4,794.73	5,137.69	4,952.19	20.94	18.97	90.109	135.16	-447.25	418.30	382.24	36.07	11.598		
5,000.00	4,877.93	5,125.17	4,947.06	20.99	18.82	91.906	133.49	-435.95	383.98	345.89	38.09	10.081		
5,093.62	4,946.03	5,103.08	4,937.41	21.04	18.56	89.769	130.10	-416.37	373.31	334.66	38.65	9.658 SF		
5,100.00	4,950.28	5,100.81	4,936.38	21.04	18.54	89.439	129.74	-414.38	373.36	334.73	38.63	9.666		
5,200.00	5,009.57	5,060.61	4,917.19	21.17	18.10	82.662	123.48	-379.62	385.52	348.01	37.51	10.278		
5,300.00	5,054.00	5,018.00	4,893.98	21.45	17.68	74.231	117.28	-344.45	415.19	379.26	35.92	11.558		
5,400.00	5,082.23	4,986.00	4,874.63	21.95	17.40	66.509	112.04	-319.52	456.84	421.70	35.14	13.001		
5,500.00	5,093.39	4,945.88	4,848.85	22.72	17.07	58.402	104.37	-289.75	504.56	469.80	34.76	14.515		
5,600.00	5,094.46	4,892.20	4,811.94	23.75	16.67	54.285	94.66	-252.01	555.94	521.55	34.39	16.166		
5,700.00	5,095.47	4,848.88	4,780.29	25.03	16.38	51.323	87.94	-223.23	613.57	579.19	34.37	17.852		
5,800.00	5,096.47	4,828.00	4,764.23	26.52	16.25	49.914	84.84	-210.25	677.94	643.08	34.86	19.446		
5,900.00	5,097.48	4,796.00	4,738.58	28.17	16.07	47.813	80.03	-191.75	747.86	712.82	35.03	21.346		
6,000.00	5,098.48	4,742.39	4,694.37	29.96	15.79	44.518	72.33	-162.42	821.49	786.67	34.82	23.594		

CC - Min centre to center distance or convergent point, SF - min separation factor, ES - min ellipse separation



Anticollision Report

<b>Company:</b>	Enduring Resources LLC	<b>Local Co-ordinate Reference:</b>	Well North Alamito Unit 560H
<b>Project:</b>	Sandoval County, New Mexico NAD83 NM C	<b>TVD Reference:</b>	RKB=6876+23.5 @ 6899.50ft
<b>Reference Site:</b>	Sec 33 T23N R07W North Alamito Unit 560 562 563	<b>MD Reference:</b>	RKB=6876+23.5 @ 6899.50ft
<b>Site Error:</b>	0.00 ft	<b>North Reference:</b>	Grid
<b>Reference Well:</b>	North Alamito Unit 560H	<b>Survey Calculation Method:</b>	Minimum Curvature
<b>Well Error:</b>	0.00 ft	<b>Output errors are at</b>	2.00 sigma
<b>Reference Wellbore</b>	Original Hole	<b>Database:</b>	DT-Oct0825v17
<b>Reference Design:</b>	rev0	<b>Offset TVD Reference:</b>	Offset Datum

<b>Offset Design:</b> Sec 32 T23N R07W - N Alamito Unit #328H (Lybrook P32-2307 01H) - Orig hole - MWD surveys												<b>Offset Site Error:</b>	0.00 ft
<b>Survey Program:</b> 570-MWD												<b>Offset Well Error:</b>	0.00 ft
<b>Reference</b>												<b>Rule Assigned:</b>	
Measured Depth (ft)	Vertical Depth (ft)	Measured Depth (ft)	Vertical Depth (ft)	Semi Major Axis Reference (ft)	Semi Major Axis Offset (ft)	Highside Toolface (°)	Offset Wellbore Centre		Distance		Minimum Separation (ft)	Separation Factor	Warning
							+N/-S (ft)	+E/-W (ft)	Between Centres (ft)	Between Ellipses (ft)			
6,100.00	5,099.49	4,702.00	4,660.52	31.86	15.60	42.157	67.93	-140.84	897.20	862.36	34.84	25.753	
6,200.00	5,100.49	4,670.00	4,633.19	33.84	15.45	40.398	64.59	-124.53	975.62	940.64	34.98	27.894	
6,300.00	5,101.50	4,648.46	4,614.58	35.90	15.36	39.294	62.09	-113.97	1,056.34	1,021.13	35.21	29.999	
6,400.00	5,102.50	4,624.44	4,593.67	38.02	15.25	38.139	59.05	-102.55	1,139.02	1,103.63	35.39	32.188	



Anticollision Report

<b>Company:</b>	Enduring Resources LLC	<b>Local Co-ordinate Reference:</b>	Well North Alamito Unit 560H
<b>Project:</b>	Sandoval County, New Mexico NAD83 NM C	<b>TVD Reference:</b>	RKB=6876+23.5 @ 6899.50ft
<b>Reference Site:</b>	Sec 33 T23N R07W North Alamito Unit 560 562 563	<b>MD Reference:</b>	RKB=6876+23.5 @ 6899.50ft
<b>Site Error:</b>	0.00 ft	<b>North Reference:</b>	Grid
<b>Reference Well:</b>	North Alamito Unit 560H	<b>Survey Calculation Method:</b>	Minimum Curvature
<b>Well Error:</b>	0.00 ft	<b>Output errors are at</b>	2.00 sigma
<b>Reference Wellbore</b>	Original Hole	<b>Database:</b>	DT-Oct0825v17
<b>Reference Design:</b>	rev0	<b>Offset TVD Reference:</b>	Offset Datum

Offset Design: Sec 33 T23N R07W North Alamito Unit 560 562 563 - Federal I #003 - Orig hole - Inc only surveys													Offset Site Error:	0.00 ft
Survey Program: 1120-INC-ONLY													Offset Well Error:	0.00 ft
Reference	Vertical	Offset	Vertical	Semi Major Axis		Highside	Offset Wellbore Centre		Distance		Minimum	Separation	Warning	
Measured Depth (ft)	Depth (ft)	Measured Depth (ft)	Depth (ft)	Reference (ft)	Offset (ft)	Toolface (°)	+N/-S (ft)	+E/-W (ft)	Between Centres (ft)	Between Ellipses (ft)	Separation (ft)	Factor		
0.00	0.00	0.00	0.00	0.00	0.00	74.112	219.14	769.94	801.54					
100.00	100.00	59.50	59.50	0.27	4.14	74.112	219.14	769.94	800.52	796.10	4.42	181.229		
200.00	200.00	159.50	159.50	0.63	11.11	74.112	219.14	769.94	800.52	788.78	11.74	68.198		
300.00	300.00	259.50	259.50	0.99	18.07	74.112	219.14	769.94	800.52	781.46	19.06	42.001		
400.00	400.00	359.50	359.50	1.35	25.03	74.112	219.14	769.94	800.52	774.14	26.38	30.345		
500.00	500.00	459.50	459.50	1.71	31.99	74.112	219.14	769.94	800.52	766.82	33.70	23.753		
600.00	600.00	559.50	559.50	2.07	38.96	74.112	219.14	769.94	800.52	759.50	41.02	19.514		
700.00	700.00	659.50	659.50	2.43	45.92	74.112	219.14	769.94	800.52	752.18	48.34	16.559		
800.00	800.00	759.50	759.50	2.78	52.88	74.112	219.14	769.94	800.52	744.86	55.66	14.381		
900.00	900.00	859.50	859.50	3.14	59.84	74.112	219.14	769.94	800.52	737.53	62.99	12.710		
1,000.00	1,000.00	959.50	959.50	3.50	66.81	74.112	219.14	769.94	800.52	730.21	70.31	11.386		
1,100.00	1,099.95	1,059.45	1,059.45	3.86	73.77	119.445	219.14	769.94	801.81	724.18	77.62	10.330		
1,200.00	1,199.63	1,159.14	1,159.13	4.22	78.49	119.829	219.14	769.94	805.69	723.00	82.70	9.743		
1,300.00	1,298.77	1,258.27	1,258.27	4.58	79.76	120.451	219.14	769.94	812.29	727.95	84.34	9.631		
1,400.00	1,397.08	1,356.59	1,356.58	4.96	81.03	121.289	219.14	769.94	821.76	735.78	85.98	9.558		
1,500.00	1,494.31	1,453.93	1,453.93	5.37	82.29	122.298	219.39	769.94	834.37	746.74	87.62	9.522		
1,600.00	1,590.90	1,550.65	1,550.64	5.81	83.53	123.748	219.29	769.94	848.79	759.51	89.28	9.507		
1,700.00	1,687.50	1,647.01	1,647.00	6.27	84.95	125.149	219.14	769.94	863.74	772.64	91.11	9.481		
1,800.00	1,784.10	1,743.61	1,743.60	6.74	87.06	126.497	219.14	769.94	879.23	785.58	93.64	9.389		
1,900.00	1,880.69	1,840.21	1,840.19	7.22	89.18	127.800	219.14	769.94	895.20	799.01	96.19	9.307		
2,000.00	1,977.29	1,936.80	1,936.79	7.72	91.30	129.059	219.14	769.94	911.62	812.88	98.73	9.233		
2,100.00	2,073.88	2,033.40	2,033.38	8.22	93.41	130.274	219.14	769.94	928.47	827.19	101.28	9.168		
2,200.00	2,170.48	2,129.99	2,129.98	8.73	95.53	131.447	219.14	769.94	945.73	841.90	103.82	9.109		
2,300.00	2,267.07	2,226.60	2,226.58	9.25	97.64	132.506	220.38	769.94	963.41	857.04	106.37	9.057		
2,400.00	2,363.67	2,323.20	2,323.18	9.77	99.76	133.604	220.32	769.94	981.39	872.48	108.91	9.011		
2,500.00	2,460.27	2,419.78	2,419.75	10.29	101.87	134.666	220.18	769.94	999.73	888.27	111.46	8.970		
2,600.00	2,556.86	2,516.33	2,516.30	10.82	103.99	135.696	219.98	769.94	1,018.39	904.40	114.00	8.934		
2,700.00	2,653.46	2,612.85	2,612.83	11.35	106.10	136.692	219.71	769.94	1,037.38	920.85	116.53	8.902		
2,800.00	2,750.05	2,709.35	2,709.32	11.89	108.22	137.658	219.36	769.94	1,056.67	937.61	119.07	8.875		
2,900.00	2,846.65	2,806.23	2,806.15	12.42	110.69	138.585	219.14	769.94	1,076.24	954.29	121.96	8.825		
3,000.00	2,943.25	2,902.83	2,902.75	12.96	113.56	139.467	219.14	769.94	1,096.06	970.82	125.24	8.752		
3,100.00	3,039.84	2,999.42	2,999.34	13.50	116.43	140.318	219.14	769.94	1,116.13	987.61	128.52	8.684		
3,200.00	3,136.44	3,096.02	3,095.94	14.04	119.30	141.140	219.14	769.94	1,136.43	1,004.63	131.80	8.622		
3,300.00	3,233.03	3,192.62	3,192.53	14.58	122.17	141.934	219.14	769.94	1,156.96	1,021.88	135.08	8.565		
3,400.00	3,329.63	3,289.21	3,289.13	15.13	125.03	142.700	219.14	769.94	1,177.69	1,039.33	138.36	8.512		
3,500.00	3,426.23	3,385.67	3,385.57	15.67	127.90	143.354	220.94	769.94	1,198.34	1,056.71	141.63	8.461		
5,100.00	4,950.28	4,910.11	4,909.78	21.04	156.43	5.285	219.14	769.94	1,148.77	973.61	175.17	6.558		
5,200.00	5,009.57	4,969.40	4,969.07	21.17	157.27	7.195	219.14	769.94	1,068.57	892.49	176.07	6.069		
5,300.00	5,054.00	5,013.45	5,013.10	21.45	157.89	10.993	219.97	769.94	979.13	802.39	176.73	5.540		
5,400.00	5,082.23	5,041.26	5,040.92	21.95	158.28	21.619	219.90	769.94	883.61	706.47	177.14	4.988		
5,500.00	5,093.39	5,052.33	5,051.98	22.72	158.44	73.751	219.86	769.94	784.72	607.40	177.32	4.426		
5,600.00	5,094.46	5,053.46	5,053.11	23.75	158.45	83.676	219.85	769.94	685.18	507.81	177.36	3.863		
5,700.00	5,095.47	5,054.54	5,054.19	25.03	158.47	84.552	219.85	769.94	585.79	408.36	177.43	3.301		
5,800.00	5,096.47	5,055.61	5,055.26	26.52	158.48	85.432	219.84	769.94	486.64	309.10	177.54	2.741		
5,900.00	5,097.48	5,056.69	5,056.34	28.17	158.50	86.317	219.84	769.94	387.94	210.19	177.74	2.183		
6,000.00	5,098.48	5,057.77	5,057.42	29.96	158.52	87.205	219.83	769.94	290.12	111.95	178.16	1.628 Level 3<2.00		
6,100.00	5,099.49	5,058.85	5,058.50	31.86	158.53	88.098	219.83	769.94	194.51	15.39	179.13	1.086 Level 3<2.00		
6,200.00	5,100.49	5,059.94	5,059.59	33.84	158.55	88.993	219.82	769.94	107.25	-71.03	178.28	0.602 Level 3<2.00		
6,281.69	5,101.31	5,060.83	5,060.48	35.52	158.56	89.726	219.82	769.94	69.51	-116.63	186.13	0.373 Level 3<2.00, CC, SF		
6,300.00	5,101.50	5,061.03	5,060.68	35.90	158.56	89.890	219.82	769.94	71.88	-116.83	188.71	0.381 Level 3<2.00, ES		
6,400.00	5,102.50	5,062.12	5,061.77	38.02	158.58	90.790	219.81	769.94	137.22	-45.17	182.38	0.752 Level 3<2.00		

CC - Min centre to center distance or convergent point, SF - min separation factor, ES - min ellipse separation



Anticollision Report

<b>Company:</b>	Enduring Resources LLC	<b>Local Co-ordinate Reference:</b>	Well North Alamito Unit 560H
<b>Project:</b>	Sandoval County, New Mexico NAD83 NM C	<b>TVD Reference:</b>	RKB=6876+23.5 @ 6899.50ft
<b>Reference Site:</b>	Sec 33 T23N R07W North Alamito Unit 560 562 563	<b>MD Reference:</b>	RKB=6876+23.5 @ 6899.50ft
<b>Site Error:</b>	0.00 ft	<b>North Reference:</b>	Grid
<b>Reference Well:</b>	North Alamito Unit 560H	<b>Survey Calculation Method:</b>	Minimum Curvature
<b>Well Error:</b>	0.00 ft	<b>Output errors are at</b>	2.00 sigma
<b>Reference Wellbore</b>	Original Hole	<b>Database:</b>	DT-Oct0825v17
<b>Reference Design:</b>	rev0	<b>Offset TVD Reference:</b>	Offset Datum

<b>Offset Design:</b> Sec 33 T23N R07W North Alamito Unit 560 562 563 - Federal I #003 - Orig hole - Inc only surveys													<b>Offset Site Error:</b>	0.00 ft		
<b>Survey Program:</b> 1120-INC-ONLY													<b>Offset Well Error:</b>	0.00 ft		
<b>Reference</b>													<b>Rule Assigned:</b>			
<b>Offset</b>				<b>Semi Major Axis</b>			<b>Offset Wellbore Centre</b>		<b>Distance</b>		<b>Minimum Separation</b>		<b>Separation Factor</b>		<b>Warning</b>	
<b>Measured Depth (ft)</b>	<b>Vertical Depth (ft)</b>	<b>Measured Depth (ft)</b>	<b>Vertical Depth (ft)</b>	<b>Reference (ft)</b>	<b>Offset (ft)</b>	<b>Highside Toolface (°)</b>	<b>+N/-S (ft)</b>	<b>+E/-W (ft)</b>	<b>Between Centres (ft)</b>	<b>Between Ellipses (ft)</b>	<b>Minimum Separation (ft)</b>	<b>Separation Factor</b>				
6,500.00	5,103.51	5,063.22	5,062.87	40.19	158.59	91.692	219.81	769.94	229.10	49.46	179.64	1.275	Level 3<2.00			
6,600.00	5,104.51	5,064.31	5,063.96	42.41	158.61	92.595	219.80	769.94	325.80	147.04	178.76	1.823	Level 3<2.00			
6,700.00	5,105.52	5,065.42	5,065.06	44.66	158.62	93.499	219.80	769.94	424.03	245.66	178.37	2.377				
6,800.00	5,106.52	5,066.52	5,066.17	46.94	158.64	94.403	219.79	769.94	522.93	344.75	178.18	2.935				
6,900.00	5,107.53	5,067.62	5,067.27	49.25	158.65	95.308	219.78	769.94	622.18	444.11	178.07	3.494				
7,000.00	5,108.53	5,068.73	5,068.38	51.59	158.67	96.211	219.78	769.94	721.63	543.62	178.01	4.054				
7,100.00	5,109.54	5,069.85	5,069.49	53.94	158.69	97.114	219.77	769.94	821.22	643.24	177.98	4.614				
7,200.00	5,110.55	5,070.96	5,070.61	56.31	158.70	98.016	219.77	769.94	920.89	742.93	177.96	5.175				
7,300.00	5,111.55	5,072.08	5,071.73	58.70	158.72	98.915	219.76	769.94	1,020.63	842.67	177.96	5.735				
7,400.00	5,112.56	5,073.20	5,072.85	61.10	158.73	99.813	219.75	769.94	1,120.41	942.44	177.97	6.296				

CC - Min centre to center distance or convergent point, SF - min separation factor, ES - min ellipse separation



Anticollision Report

<b>Company:</b>	Enduring Resources LLC	<b>Local Co-ordinate Reference:</b>	Well North Alamito Unit 560H
<b>Project:</b>	Sandoval County, New Mexico NAD83 NM C	<b>TVD Reference:</b>	RKB=6876+23.5 @ 6899.50ft
<b>Reference Site:</b>	Sec 33 T23N R07W North Alamito Unit 560 562 563	<b>MD Reference:</b>	RKB=6876+23.5 @ 6899.50ft
<b>Site Error:</b>	0.00 ft	<b>North Reference:</b>	Grid
<b>Reference Well:</b>	North Alamito Unit 560H	<b>Survey Calculation Method:</b>	Minimum Curvature
<b>Well Error:</b>	0.00 ft	<b>Output errors are at</b>	2.00 sigma
<b>Reference Wellbore</b>	Original Hole	<b>Database:</b>	DT-Oct0825v17
<b>Reference Design:</b>	rev0	<b>Offset TVD Reference:</b>	Offset Datum

Offset Design: Sec 33 T23N R07W North Alamito Unit 560 562 563 - N Alamito Unit #323H ( - Orig hole - MWD surveys													Offset Site Error:	0.00 ft
Survey Program: 625-MWD													Offset Well Error:	0.00 ft
Measured Depth (ft)	Reference Vertical Depth (ft)	Offset		Semi Major Axis		Highside Toolface (°)	Offset Wellbore Centre		Distance		Minimum Separation (ft)	Separation Factor	Warning	
		Measured Depth (ft)	Vertical Depth (ft)	Reference (ft)	Offset (ft)		+N/-S (ft)	+E/-W (ft)	Between Centres (ft)	Between Ellipses (ft)				
0.00	0.00	0.00	0.00	0.00	0.00	22.459	820.77	339.28	888.24					
100.00	100.00	82.52	82.52	0.27	0.14	22.461	820.88	339.36	888.27	887.85	0.42	2,123.104		
200.00	200.00	179.03	179.03	0.63	0.31	22.469	821.31	339.67	888.80	887.85	0.95	940.206		
300.00	300.00	275.53	275.52	0.99	0.48	22.483	822.05	340.22	889.72	888.25	1.47	604.368		
400.00	400.00	372.02	372.01	1.35	0.65	22.503	823.10	340.99	891.04	889.04	2.00	445.769		
500.00	500.00	468.51	468.48	1.71	0.82	22.529	824.48	341.99	892.75	890.23	2.53	353.492		
600.00	600.00	564.97	564.92	2.07	0.99	22.560	826.16	343.23	894.86	891.80	3.05	293.195		
700.00	700.00	664.51	664.42	2.43	1.24	22.597	828.17	344.68	897.29	893.63	3.66	245.368		
800.00	800.00	763.20	763.09	2.78	1.59	22.621	830.16	345.91	899.62	895.25	4.37	205.893		
900.00	900.00	860.47	860.32	3.14	1.94	22.631	832.53	347.08	902.33	897.25	5.08	177.745		
1,000.00	1,000.00	959.58	959.39	3.50	2.30	22.637	835.05	348.24	905.13	899.34	5.79	156.315		
1,100.00	1,099.95	1,058.60	1,058.37	3.86	2.66	67.952	837.74	349.59	907.18	900.68	6.50	139.529		
1,200.00	1,199.63	1,159.25	1,158.98	4.22	3.02	68.429	840.38	350.96	907.21	899.99	7.22	125.652		
1,300.00	1,298.77	1,256.52	1,256.20	4.58	3.37	69.221	843.00	352.03	905.39	897.45	7.93	114.112		
1,400.00	1,397.08	1,356.17	1,355.81	4.96	3.73	70.358	845.95	352.72	902.02	893.35	8.67	104.006		
1,500.00	1,494.31	1,455.66	1,455.25	5.37	4.08	71.836	848.97	353.10	897.23	887.79	9.44	95.084		
1,600.00	1,590.90	1,552.18	1,551.72	5.81	4.43	73.286	851.95	353.20	892.11	881.89	10.22	87.325		
1,700.00	1,687.50	1,650.66	1,650.16	6.27	4.78	74.771	854.97	353.14	887.50	876.48	11.02	80.515		
1,800.00	1,784.10	1,747.69	1,747.15	6.74	5.13	76.260	857.81	353.21	883.46	871.62	11.84	74.608		
1,900.00	1,880.69	1,847.46	1,846.88	7.22	5.49	77.811	860.51	353.30	879.89	867.20	12.68	69.372		
2,000.00	1,977.29	1,944.64	1,944.02	7.72	5.84	79.321	863.15	353.18	876.86	863.33	13.53	64.819		
2,100.00	2,073.88	2,042.43	2,041.78	8.22	6.19	80.862	865.69	353.20	874.47	860.09	14.38	60.796		
2,200.00	2,170.48	2,143.43	2,142.76	8.73	6.55	82.470	867.91	353.11	872.36	857.10	15.26	57.173		
2,300.00	2,267.07	2,241.30	2,240.61	9.25	6.90	84.045	869.78	353.01	870.71	854.59	16.13	53.990		
2,400.00	2,363.67	2,339.20	2,338.49	9.77	7.25	85.618	871.65	352.77	869.66	852.66	17.00	51.154		
2,500.00	2,460.27	2,440.92	2,440.19	10.29	7.61	87.254	873.36	352.28	868.98	851.09	17.89	48.576		
2,600.00	2,556.86	2,539.30	2,538.56	10.82	7.96	88.838	874.72	351.55	868.59	849.82	18.77	46.285		
2,618.07	2,574.32	2,557.14	2,556.40	10.92	8.02	89.128	874.93	351.43	868.58	849.66	18.92	45.896		
2,700.00	2,653.46	2,636.44	2,635.69	11.35	8.31	90.429	875.71	351.04	868.80	849.16	19.64	44.237		
2,800.00	2,750.05	2,733.86	2,733.11	11.89	8.65	92.034	876.59	350.71	869.76	849.24	20.51	42.397		
2,900.00	2,846.65	2,831.89	2,831.13	12.42	9.00	93.661	877.22	350.45	871.34	849.95	21.39	40.736		
3,000.00	2,943.25	2,929.86	2,929.10	12.96	9.34	95.278	877.70	349.98	873.38	851.13	22.26	39.237		
3,100.00	3,039.84	3,027.38	3,026.62	13.50	9.69	96.880	878.17	349.51	876.14	853.02	23.12	37.890		
3,200.00	3,136.44	3,124.66	3,123.90	14.04	10.02	98.478	878.44	349.06	879.51	855.53	23.98	36.676		
3,300.00	3,233.03	3,223.83	3,223.07	14.58	10.37	100.091	878.70	348.51	883.51	858.68	24.84	35.572		
3,400.00	3,329.63	3,321.73	3,320.96	15.13	10.70	101.688	878.53	347.86	887.90	862.23	25.68	34.580		
3,500.00	3,426.23	3,420.93	3,420.17	15.67	11.03	103.295	878.23	347.18	892.92	866.41	26.51	33.678		
3,600.00	3,522.82	3,516.55	3,515.78	16.22	11.35	104.836	877.73	346.42	898.44	871.11	27.33	32.874		
3,700.00	3,619.42	3,614.48	3,613.71	16.76	11.69	106.387	877.38	345.72	904.80	876.65	28.15	32.142		
3,800.00	3,716.01	3,709.73	3,708.96	17.31	12.01	107.879	876.93	344.94	911.70	882.75	28.95	31.488		
3,900.00	3,812.61	3,806.53	3,805.75	17.86	12.34	109.376	876.50	344.34	919.45	889.69	29.76	30.900		
4,000.00	3,909.67	3,903.67	3,902.88	18.39	12.67	110.933	875.97	343.69	927.07	896.54	30.54	30.358		
4,100.00	4,007.85	4,000.37	3,999.58	18.86	12.99	112.176	875.46	343.07	933.35	902.07	31.28	29.843		
4,200.00	4,106.88	4,099.54	4,098.76	19.27	13.33	113.094	874.98	342.57	938.04	906.06	31.98	29.330		
4,300.00	4,206.50	4,206.55	4,205.61	19.63	13.71	113.458	877.82	340.21	940.38	907.68	32.71	28.753		
4,400.00	4,306.43	5,114.00	4,885.17	19.94	13.91	82.616	1,092.61	-111.97	919.73	889.10	30.64	30.022		
4,500.00	4,406.43	5,158.34	4,910.56	20.21	13.83	34.563	1,093.85	-148.31	857.25	825.00	32.25	26.584		
4,600.00	4,506.43	5,339.89	4,999.49	20.49	22.30	22.039	1,099.41	-305.74	795.39	762.57	32.83	24.231		
4,700.00	4,606.11	5,375.06	5,012.07	20.72	22.86	-88.063	1,101.18	-338.54	733.98	698.85	35.13	20.891		
4,800.00	4,703.19	5,386.15	5,015.93	20.86	23.04	-95.460	1,101.81	-348.91	680.44	642.97	37.47	18.160		
4,900.00	4,794.73	5,381.33	5,014.25	20.94	22.96	-99.460	1,101.53	-344.40	639.56	600.09	39.48	16.201		

CC - Min centre to center distance or convergent point, SF - min separation factor, ES - min ellipse separation



Anticollision Report

<b>Company:</b>	Enduring Resources LLC	<b>Local Co-ordinate Reference:</b>	Well North Alamito Unit 560H
<b>Project:</b>	Sandoval County, New Mexico NAD83 NM C	<b>TVD Reference:</b>	RKB=6876+23.5 @ 6899.50ft
<b>Reference Site:</b>	Sec 33 T23N R07W North Alamito Unit 560 562 563	<b>MD Reference:</b>	RKB=6876+23.5 @ 6899.50ft
<b>Site Error:</b>	0.00 ft	<b>North Reference:</b>	Grid
<b>Reference Well:</b>	North Alamito Unit 560H	<b>Survey Calculation Method:</b>	Minimum Curvature
<b>Well Error:</b>	0.00 ft	<b>Output errors are at</b>	2.00 sigma
<b>Reference Wellbore</b>	Original Hole	<b>Database:</b>	DT-Oct0825v17
<b>Reference Design:</b>	rev0	<b>Offset TVD Reference:</b>	Offset Datum

Offset Design: Sec 33 T23N R07W North Alamito Unit 560 562 563 - N Alamito Unit #323H ( - Orig hole - MWD surveys													Offset Site Error:	0.00 ft
Survey Program: 625-MWD													Offset Well Error:	0.00 ft
Measured Depth (ft)	Vertical Reference Depth (ft)	Offset		Semi Major Axis		Highside Toolface (°)	Offset Wellbore Centre		Distance		Minimum Separation (ft)	Separation Factor	Warning	
		Measured Depth (ft)	Vertical Depth (ft)	Reference (ft)	Offset (ft)		+N/-S (ft)	+E/-W (ft)	Between Centres (ft)	Between Ellipses (ft)				
5,000.00	4,877.93	5,360.82	5,007.05	20.99	22.63	-100.103	1,100.42	-325.23	614.82	573.99	40.83	15.058		
5,095.24	4,947.11	5,326.90	4,994.62	21.04	22.10	-97.883	1,098.82	-293.71	607.31	565.97	41.33	14.693 CC, ES		
5,100.00	4,950.28	5,324.87	4,993.84	21.04	22.06	-97.708	1,098.73	-291.84	607.33	565.99	41.34	14.692 SF		
5,200.00	5,009.57	5,280.56	4,975.67	21.17	21.40	-93.237	1,096.95	-251.47	615.52	574.39	41.13	14.965		
5,300.00	5,054.00	5,240.00	4,956.42	21.45	20.84	-87.952	1,095.73	-215.80	636.66	596.04	40.63	15.671		
5,400.00	5,082.23	5,178.36	4,922.16	21.95	20.06	-80.517	1,094.44	-164.60	667.32	627.35	39.97	16.694		
5,500.00	5,093.39	5,114.00	4,885.17	22.72	19.31	-73.378	1,092.61	-111.97	701.54	662.04	39.50	17.760		
5,600.00	5,094.46	5,040.02	4,843.06	23.75	18.53	-69.894	1,092.39	-51.15	738.73	699.48	39.24	18.825		
5,700.00	5,095.47	4,956.00	4,795.36	25.03	17.74	-66.564	1,091.99	18.02	778.49	739.37	39.11	19.903		
5,800.00	5,096.47	4,769.29	4,680.71	26.52	16.33	-58.969	1,076.17	163.81	820.21	782.23	37.98	21.598		
5,900.00	5,097.48	4,678.67	4,617.39	28.17	15.77	-54.489	1,050.61	223.13	855.01	817.33	37.68	22.689		
6,000.00	5,098.48	4,640.00	4,587.99	29.96	15.55	-52.368	1,036.76	244.06	894.86	856.73	38.14	23.465		
6,100.00	5,099.49	4,608.47	4,562.93	31.86	15.39	-50.583	1,024.99	259.14	941.68	903.05	38.64	24.374		
6,200.00	5,100.49	4,559.64	4,523.27	33.84	15.15	-47.791	1,005.77	280.13	994.34	955.62	38.72	25.679		
6,300.00	5,101.50	4,521.71	4,492.20	35.90	14.97	-45.629	989.98	295.08	1,051.92	1,013.00	38.92	27.028		
6,400.00	5,102.50	4,494.21	4,469.45	38.02	14.84	-44.038	977.68	304.42	1,114.26	1,075.05	39.20	28.421		
6,500.00	5,103.51	4,482.00	4,459.29	40.19	14.79	-43.326	972.02	308.14	1,181.05	1,141.39	39.66	29.776		

CC - Min centre to center distance or convergent point, SF - min separation factor, ES - min ellipse separation



Anticollision Report

<b>Company:</b>	Enduring Resources LLC	<b>Local Co-ordinate Reference:</b>	Well North Alamito Unit 560H
<b>Project:</b>	Sandoval County, New Mexico NAD83 NM C	<b>TVD Reference:</b>	RKB=6876+23.5 @ 6899.50ft
<b>Reference Site:</b>	Sec 33 T23N R07W North Alamito Unit 560 562 563	<b>MD Reference:</b>	RKB=6876+23.5 @ 6899.50ft
<b>Site Error:</b>	0.00 ft	<b>North Reference:</b>	Grid
<b>Reference Well:</b>	North Alamito Unit 560H	<b>Survey Calculation Method:</b>	Minimum Curvature
<b>Well Error:</b>	0.00 ft	<b>Output errors are at</b>	2.00 sigma
<b>Reference Wellbore</b>	Original Hole	<b>Database:</b>	DT-Oct0825v17
<b>Reference Design:</b>	rev0	<b>Offset TVD Reference:</b>	Offset Datum

Offset Design: Sec 33 T23N R07W North Alamito Unit 560 562 563 - North Alamito Unit 562H - Original Hole - rev0													Offset Site Error:	0.00 ft
Survey Program: 0-MWD													Offset Well Error:	0.00 ft
Reference	Vertical	Offset	Vertical	Semi Major Axis		Highside	Offset Wellbore Centre		Distance		Minimum	Separation	Warning	
Measured Depth (ft)	Depth (ft)	Measured Depth (ft)	Depth (ft)	Reference (ft)	Offset (ft)	Toolface (°)	+N/-S (ft)	+E/-W (ft)	Between Centres (ft)	Between Ellipses (ft)	Separation (ft)	Factor		
0.00	0.00	0.00	0.00	0.00	0.00	-175.835	-20.01	-1.46	20.06					
100.00	100.00	100.00	100.00	0.27	0.27	-175.835	-20.01	-1.46	20.06	19.51	0.55	36.573		
200.00	200.00	200.00	200.00	0.63	0.63	-175.835	-20.01	-1.46	20.06	18.79	1.27	15.852		
300.00	300.00	300.00	300.00	0.99	0.99	-175.835	-20.01	-1.46	20.06	18.08	1.98	10.119		
400.00	400.00	400.00	400.00	1.35	1.35	-175.835	-20.01	-1.46	20.06	17.36	2.70	7.431		
500.00	500.00	500.00	500.00	1.71	1.71	-175.835	-20.01	-1.46	20.06	16.64	3.42	5.872		
600.00	600.00	600.00	600.00	2.07	2.07	-175.835	-20.01	-1.46	20.06	15.93	4.13	4.853		
700.00	700.00	700.00	700.00	2.43	2.43	-175.835	-20.01	-1.46	20.06	15.21	4.85	4.136		
800.00	800.00	800.00	800.00	2.78	2.78	-175.835	-20.01	-1.46	20.06	14.49	5.57	3.603		
900.00	900.00	900.00	900.00	3.14	3.14	-175.835	-20.01	-1.46	20.06	13.78	6.28	3.192		
1,000.00	1,000.00	1,000.00	1,000.00	3.50	3.50	-175.835	-20.01	-1.46	20.06	13.06	7.00	2.865 CC, ES		
1,100.00	1,099.95	1,099.95	1,099.95	3.86	3.86	-135.808	-20.01	-1.46	21.85	14.14	7.72	2.832 SF		
1,200.00	1,199.63	1,199.14	1,199.10	4.22	4.20	-141.952	-21.23	-3.72	28.84	20.42	8.42	3.426		
1,300.00	1,298.77	1,297.65	1,297.30	4.58	4.54	-142.822	-24.85	-10.45	41.91	32.80	9.11	4.600		
1,400.00	1,397.08	1,394.93	1,393.76	4.96	4.88	-141.483	-30.78	-21.47	60.83	51.01	9.82	6.197		
1,500.00	1,494.31	1,490.46	1,487.75	5.37	5.23	-139.604	-38.87	-36.48	85.53	74.99	10.53	8.118		
1,600.00	1,590.90	1,584.31	1,579.13	5.81	5.60	-137.459	-48.97	-55.23	114.04	102.77	11.27	10.121		
1,700.00	1,687.50	1,676.54	1,667.83	6.27	6.00	-134.487	-60.96	-77.49	144.71	132.70	12.01	12.047		
1,800.00	1,784.10	1,766.79	1,753.33	6.74	6.43	-131.277	-74.64	-102.90	177.87	165.10	12.77	13.930		
1,900.00	1,880.69	1,854.73	1,835.24	7.22	6.90	-128.096	-89.80	-131.05	213.77	200.24	13.53	15.804		
2,000.00	1,977.29	1,940.08	1,913.25	7.72	7.40	-125.072	-106.21	-161.52	252.59	238.32	14.28	17.692		
2,100.00	2,073.88	2,022.65	1,987.17	8.22	7.94	-122.262	-123.65	-193.88	294.44	279.43	15.01	19.613		
2,200.00	2,170.48	2,100.00	2,054.93	8.73	8.49	-119.757	-141.34	-226.73	339.34	323.66	15.68	21.641		
2,300.00	2,267.07	2,178.81	2,122.34	9.25	9.12	-117.343	-160.68	-262.65	387.23	370.81	16.42	23.581		
2,400.00	2,363.67	2,252.24	2,183.60	9.77	9.76	-115.223	-179.88	-298.30	438.08	420.99	17.09	25.636		
2,500.00	2,460.27	2,322.54	2,240.74	10.29	10.41	-113.308	-199.30	-334.35	491.76	474.04	17.72	27.752		
2,600.00	2,556.86	2,389.72	2,293.91	10.82	11.08	-111.579	-218.77	-370.51	548.15	529.83	18.32	29.922		
2,700.00	2,653.46	2,453.84	2,343.27	11.35	11.77	-110.018	-238.17	-406.53	607.12	588.23	18.90	32.130		
2,800.00	2,750.05	2,514.95	2,389.02	11.89	12.45	-108.607	-257.39	-442.20	668.53	649.10	19.43	34.407		
2,900.00	2,846.65	2,580.65	2,436.91	12.42	13.23	-107.184	-278.72	-481.80	732.06	711.97	20.09	36.436		
3,000.00	2,943.25	2,655.93	2,491.53	12.96	14.15	-105.772	-303.27	-527.40	796.23	775.26	20.97	37.964		
3,100.00	3,039.84	2,731.20	2,546.15	13.50	15.08	-104.564	-327.83	-573.00	860.65	838.78	21.87	39.360		
3,200.00	3,136.44	2,806.47	2,600.78	14.04	16.03	-103.520	-352.39	-618.59	925.27	902.50	22.77	40.637		
3,300.00	3,233.03	2,881.74	2,655.40	14.58	17.00	-102.609	-376.95	-664.19	990.05	966.37	23.69	41.800		
3,400.00	3,329.63	2,957.01	2,710.03	15.13	17.97	-101.807	-401.50	-709.79	1,054.96	1,030.35	24.61	42.867		
3,500.00	3,426.23	3,032.28	2,764.65	15.67	18.96	-101.097	-426.06	-755.38	1,119.98	1,094.44	25.54	43.848		
3,600.00	3,522.82	3,107.56	2,819.27	16.22	19.95	-100.464	-450.62	-800.98	1,185.09	1,158.61	26.48	44.755		
9,200.00	5,130.65	11,331.12	5,101.34	105.59	147.69	88.481	-1,436.56	3,628.02	1,195.05	942.98	252.07	4.741		
9,300.00	5,131.66	11,429.81	5,102.46	108.11	150.09	88.467	-1,438.58	3,726.68	1,178.90	921.96	256.94	4.588		
9,400.00	5,132.66	11,528.49	5,103.58	110.62	152.50	88.453	-1,440.60	3,825.34	1,162.75	900.93	261.82	4.441		
9,500.00	5,133.67	11,627.18	5,104.69	113.13	154.91	88.438	-1,442.62	3,924.00	1,146.60	879.89	266.70	4.299		
9,600.00	5,134.67	11,725.86	5,105.81	115.65	157.33	88.423	-1,444.65	4,022.66	1,130.44	858.85	271.59	4.162		
9,700.00	5,135.68	11,824.55	5,106.93	118.17	159.75	88.408	-1,446.67	4,121.32	1,114.29	837.81	276.48	4.030		
9,800.00	5,136.68	11,923.24	5,108.05	120.69	162.17	88.392	-1,448.69	4,219.98	1,098.14	816.77	281.37	3.903		
9,900.00	5,137.69	12,021.92	5,109.17	123.21	164.59	88.375	-1,450.71	4,318.64	1,081.99	795.72	286.27	3.780		
10,000.00	5,138.69	12,120.61	5,110.29	125.73	167.02	88.358	-1,452.73	4,417.30	1,065.84	774.67	291.17	3.661		
10,030.35	5,139.00	12,150.57	5,110.63	126.50	167.75	88.353	-1,453.34	4,447.24	1,060.94	768.28	292.66	3.625		

CC - Min centre to center distance or convergent point, SF - min separation factor, ES - min ellipse separation



Anticollision Report

<b>Company:</b>	Enduring Resources LLC	<b>Local Co-ordinate Reference:</b>	Well North Alamito Unit 560H
<b>Project:</b>	Sandoval County, New Mexico NAD83 NM C	<b>TVD Reference:</b>	RKB=6876+23.5 @ 6899.50ft
<b>Reference Site:</b>	Sec 33 T23N R07W North Alamito Unit 560 562 563	<b>MD Reference:</b>	RKB=6876+23.5 @ 6899.50ft
<b>Site Error:</b>	0.00 ft	<b>North Reference:</b>	Grid
<b>Reference Well:</b>	North Alamito Unit 560H	<b>Survey Calculation Method:</b>	Minimum Curvature
<b>Well Error:</b>	0.00 ft	<b>Output errors are at</b>	2.00 sigma
<b>Reference Wellbore</b>	Original Hole	<b>Database:</b>	DT-Oct0825v17
<b>Reference Design:</b>	rev0	<b>Offset TVD Reference:</b>	Offset Datum

Offset Design: Sec 33 T23N R07W North Alamito Unit 560 562 563 - North Alamito Unit 563H - Original Hole - rev0													Offset Site Error:	0.00 ft
Survey Program: 0-MWD													Offset Well Error:	0.00 ft
Measured Depth (ft)	Vertical Reference Depth (ft)	Offset		Semi Major Axis		Highside Toolface (°)	Offset Wellbore Centre		Distance		Minimum Separation (ft)	Separation Factor	Warning	
		Measured Depth (ft)	Vertical Depth (ft)	Reference (ft)	Offset (ft)		+N/-S (ft)	+E/-W (ft)	Between Centres (ft)	Between Ellipses (ft)				
0.00	0.00	0.00	0.00	0.00	0.00	-175.835	-40.01	-2.91	40.12					
100.00	100.00	100.00	100.00	0.27	0.27	-175.835	-40.01	-2.91	40.12	39.57	0.55	73.147		
200.00	200.00	200.00	200.00	0.63	0.63	-175.835	-40.01	-2.91	40.12	38.85	1.27	31.704		
300.00	300.00	300.00	300.00	0.99	0.99	-175.835	-40.01	-2.91	40.12	38.14	1.98	20.238		
400.00	400.00	400.00	400.00	1.35	1.35	-175.835	-40.01	-2.91	40.12	37.42	2.70	14.862		
500.00	500.00	500.00	500.00	1.71	1.71	-175.835	-40.01	-2.91	40.12	36.70	3.42	11.743		
600.00	600.00	600.00	600.00	2.07	2.07	-175.835	-40.01	-2.91	40.12	35.98	4.13	9.706		
700.00	700.00	700.00	700.00	2.43	2.43	-175.835	-40.01	-2.91	40.12	35.27	4.85	8.272		
800.00	800.00	800.00	800.00	2.78	2.78	-175.835	-40.01	-2.91	40.12	34.55	5.57	7.206		
900.00	900.00	900.00	900.00	3.14	3.14	-175.835	-40.01	-2.91	40.12	33.83	6.28	6.384		
1,000.00	1,000.00	1,000.00	1,000.00	3.50	3.50	-175.835	-40.01	-2.91	40.12	33.12	7.00	5.730 CC, ES		
1,100.00	1,099.95	1,098.12	1,098.08	3.86	3.84	-131.287	-42.02	-4.44	43.98	36.29	7.69	5.719 SF		
1,200.00	1,199.63	1,195.37	1,195.03	4.22	4.16	-132.668	-47.95	-8.97	55.53	47.17	8.36	6.644		
1,300.00	1,298.77	1,290.88	1,289.76	4.58	4.49	-133.926	-57.58	-16.33	74.70	65.68	9.02	8.280		
1,400.00	1,397.08	1,383.89	1,381.31	4.96	4.83	-134.742	-70.57	-26.25	101.27	91.59	9.68	10.460		
1,500.00	1,494.31	1,473.72	1,468.87	5.37	5.18	-135.133	-86.46	-38.39	134.96	124.62	10.34	13.052		
1,600.00	1,590.90	1,560.54	1,552.52	5.81	5.55	-135.491	-104.92	-52.48	173.72	162.73	10.99	15.806		
1,700.00	1,687.50	1,644.75	1,632.57	6.27	5.94	-134.997	-125.69	-68.34	215.62	203.99	11.63	18.543		
1,800.00	1,784.10	1,726.16	1,708.79	6.74	6.35	-134.108	-148.41	-85.70	260.55	248.30	12.26	21.259		
1,900.00	1,880.69	1,800.00	1,776.81	7.22	6.76	-133.115	-171.24	-103.13	308.49	295.69	12.79	24.110		
2,000.00	1,977.29	1,880.06	1,849.25	7.72	7.25	-131.934	-198.33	-123.82	359.21	345.74	13.47	26.660		
2,100.00	2,073.88	1,952.41	1,913.42	8.22	7.74	-130.826	-224.87	-144.08	412.75	398.69	14.06	29.356		
2,200.00	2,170.48	2,021.66	1,973.62	8.73	8.24	-129.756	-252.06	-164.85	468.94	454.31	14.62	32.066		
2,300.00	2,267.07	2,087.84	2,029.96	9.25	8.75	-128.742	-279.65	-185.92	527.65	512.49	15.17	34.788		
2,400.00	2,363.67	2,150.99	2,082.57	9.77	9.28	-127.789	-307.41	-207.12	588.77	573.07	15.69	37.515		
2,500.00	2,460.27	2,200.00	2,122.59	10.29	9.70	-127.064	-329.90	-224.29	652.27	636.27	16.00	40.765		
2,600.00	2,556.86	2,268.56	2,177.32	10.82	10.34	-126.074	-362.71	-249.35	717.65	700.97	16.68	43.034		
2,700.00	2,653.46	2,323.15	2,219.82	11.35	10.87	-125.307	-389.94	-270.14	785.15	768.02	17.13	45.822		
2,800.00	2,750.05	2,375.11	2,259.34	11.89	11.39	-124.596	-416.75	-290.61	854.52	836.95	17.57	48.625		
2,900.00	2,846.65	2,424.54	2,296.07	12.42	11.92	-123.936	-443.03	-310.68	925.65	907.65	17.99	51.446		
3,000.00	2,943.25	2,471.55	2,330.21	12.96	12.43	-123.325	-468.72	-330.30	998.40	980.01	18.39	54.282		
3,100.00	3,039.84	2,500.00	2,350.47	13.50	12.75	-122.962	-484.59	-342.42	1,072.87	1,054.38	18.49	58.010		
3,200.00	3,136.44	2,558.83	2,391.43	14.04	13.44	-122.230	-518.15	-368.05	1,148.39	1,129.25	19.14	59.999		

CC - Min centre to center distance or convergent point, SF - min separation factor, ES - min ellipse separation



Anticollision Report

<b>Company:</b>	Enduring Resources LLC	<b>Local Co-ordinate Reference:</b>	Well North Alamito Unit 560H
<b>Project:</b>	Sandoval County, New Mexico NAD83 NM C	<b>TVD Reference:</b>	RKB=6876+23.5 @ 6899.50ft
<b>Reference Site:</b>	Sec 33 T23N R07W North Alamito Unit 560 562 563	<b>MD Reference:</b>	RKB=6876+23.5 @ 6899.50ft
<b>Site Error:</b>	0.00 ft	<b>North Reference:</b>	Grid
<b>Reference Well:</b>	North Alamito Unit 560H	<b>Survey Calculation Method:</b>	Minimum Curvature
<b>Well Error:</b>	0.00 ft	<b>Output errors are at</b>	2.00 sigma
<b>Reference Wellbore</b>	Original Hole	<b>Database:</b>	DT-Oct0825v17
<b>Reference Design:</b>	rev0	<b>Offset TVD Reference:</b>	Offset Datum

Offset Design: Sec 34 T23N R07W - N Alamito Unit #306H - Orig Hole - MWD surveys													Offset Site Error:	0.00 ft
Survey Program: 409-MWD													Offset Well Error:	0.00 ft
Measured Depth (ft)	Vertical Reference Depth (ft)	Offset		Semi Major Axis		Highside Toolface (°)	Offset Wellbore Centre		Distance		Minimum Separation (ft)	Separation Factor	Warning	
		Measured Depth (ft)	Vertical Depth (ft)	Reference (ft)	Offset (ft)		+N/-S (ft)	+E/-W (ft)	Between Centres (ft)	Between Ellipses (ft)				
8,700.00	5,125.63	7,060.77	5,117.10	93.08	46.78	-88.637	734.68	3,938.33	1,179.08	1,055.76	123.32	9.561		
8,800.00	5,126.63	6,967.54	5,116.69	95.58	44.89	-88.497	672.82	4,008.08	1,127.44	1,004.55	122.89	9.174		
8,900.00	5,127.64	6,817.04	5,115.94	98.08	41.95	-88.228	570.39	4,118.26	1,074.37	956.81	117.56	9.139		
9,000.00	5,128.64	6,733.62	5,117.59	100.58	40.41	-88.193	511.14	4,176.95	1,017.29	899.67	117.62	8.649		
9,100.00	5,129.65	6,653.59	5,117.97	103.09	38.97	-88.069	454.32	4,233.31	960.31	842.32	117.99	8.139		
9,200.00	5,130.65	6,588.05	5,118.84	105.59	37.82	-87.999	408.33	4,279.99	904.27	784.40	119.87	7.544		
9,300.00	5,131.66	6,525.82	5,120.28	108.11	36.73	-87.979	365.69	4,325.30	850.12	727.81	122.31	6.951		
9,400.00	5,132.66	6,462.94	5,120.84	110.62	35.63	-87.884	323.80	4,372.18	798.18	673.26	124.92	6.389		
9,500.00	5,133.67	6,386.20	5,120.74	113.13	34.33	-87.692	274.16	4,430.71	748.42	622.24	126.19	5.931		
9,600.00	5,134.67	6,277.40	5,119.16	115.65	32.63	-87.234	202.52	4,512.57	697.44	573.97	123.47	5.649		
9,700.00	5,135.68	6,185.18	5,116.75	118.17	31.35	-86.651	140.31	4,580.60	644.66	522.04	122.63	5.257		
9,800.00	5,136.68	6,086.95	5,116.52	120.69	30.20	-86.165	72.85	4,651.98	590.45	469.96	120.49	4.901		
9,900.00	5,137.69	6,014.39	5,118.50	123.21	29.49	-86.001	22.57	4,704.27	535.49	413.11	122.38	4.376		
10,000.00	5,138.69	5,950.33	5,120.08	125.73	28.93	-85.827	-19.74	4,752.31	484.06	357.85	126.21	3.835		
10,030.35	5,139.00	5,928.37	5,120.51	126.50	28.76	-85.750	-33.89	4,769.11	469.06	342.04	127.02	3.693	CC, ES, SF	

CC - Min centre to center distance or convergent point, SF - min separation factor, ES - min ellipse separation



Anticollision Report

<b>Company:</b>	Enduring Resources LLC	<b>Local Co-ordinate Reference:</b>	Well North Alamito Unit 560H
<b>Project:</b>	Sandoval County, New Mexico NAD83 NM C	<b>TVD Reference:</b>	RKB=6876+23.5 @ 6899.50ft
<b>Reference Site:</b>	Sec 33 T23N R07W North Alamito Unit 560 562 563	<b>MD Reference:</b>	RKB=6876+23.5 @ 6899.50ft
<b>Site Error:</b>	0.00 ft	<b>North Reference:</b>	Grid
<b>Reference Well:</b>	North Alamito Unit 560H	<b>Survey Calculation Method:</b>	Minimum Curvature
<b>Well Error:</b>	0.00 ft	<b>Output errors are at</b>	2.00 sigma
<b>Reference Wellbore</b>	Original Hole	<b>Database:</b>	DT-Oct0825v17
<b>Reference Design:</b>	rev0	<b>Offset TVD Reference:</b>	Offset Datum

Reference Depths are relative to RKB=6876+23.5 @ 6899.50ft  
 Offset Depths are relative to Offset Datum  
 Central Meridian is -106.25000000

Coordinates are relative to: North Alamito Unit 560H  
 Coordinate System is US State Plane 1983, New Mexico Central Zone  
 Grid Convergence at Surface is: -0.790°

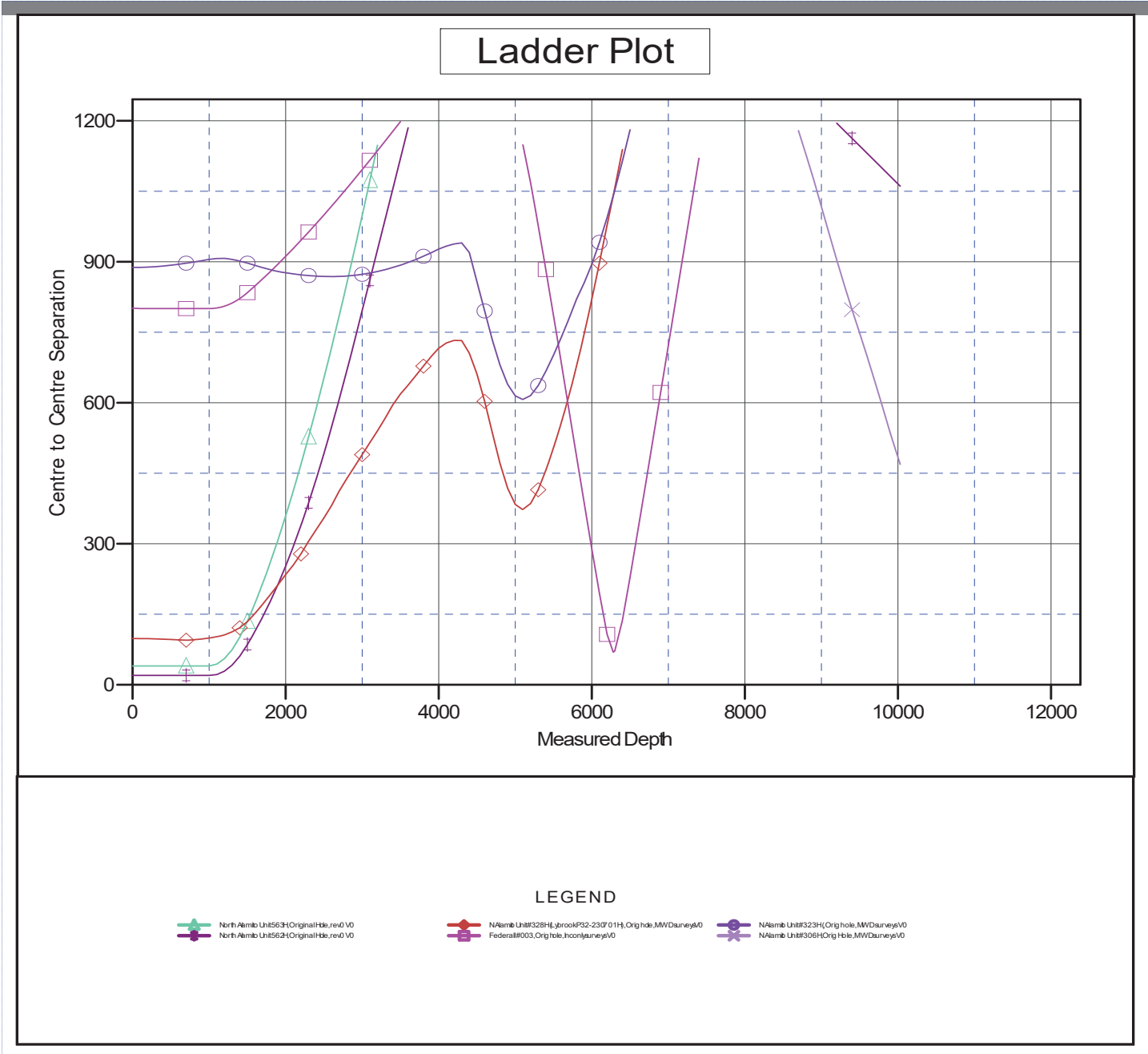



Anticollision Report

<b>Company:</b>	Enduring Resources LLC	<b>Local Co-ordinate Reference:</b>	Well North Alamito Unit 560H
<b>Project:</b>	Sandoval County, New Mexico NAD83 NM C	<b>TVD Reference:</b>	RKB=6876+23.5 @ 6899.50ft
<b>Reference Site:</b>	Sec 33 T23N R07W North Alamito Unit 560 562 563	<b>MD Reference:</b>	RKB=6876+23.5 @ 6899.50ft
<b>Site Error:</b>	0.00 ft	<b>North Reference:</b>	Grid
<b>Reference Well:</b>	North Alamito Unit 560H	<b>Survey Calculation Method:</b>	Minimum Curvature
<b>Well Error:</b>	0.00 ft	<b>Output errors are at</b>	2.00 sigma
<b>Reference Wellbore</b>	Original Hole	<b>Database:</b>	DT-Oct0825v17
<b>Reference Design:</b>	rev0	<b>Offset TVD Reference:</b>	Offset Datum

Reference Depths are relative to RKB=6876+23.5 @ 6899.50ft  
 Offset Depths are relative to Offset Datum  
 Central Meridian is -106.25000000

Coordinates are relative to: North Alamito Unit 560H  
 Coordinate System is US State Plane 1983, New Mexico Central Zone  
 Grid Convergence at Surface is: -0.790°

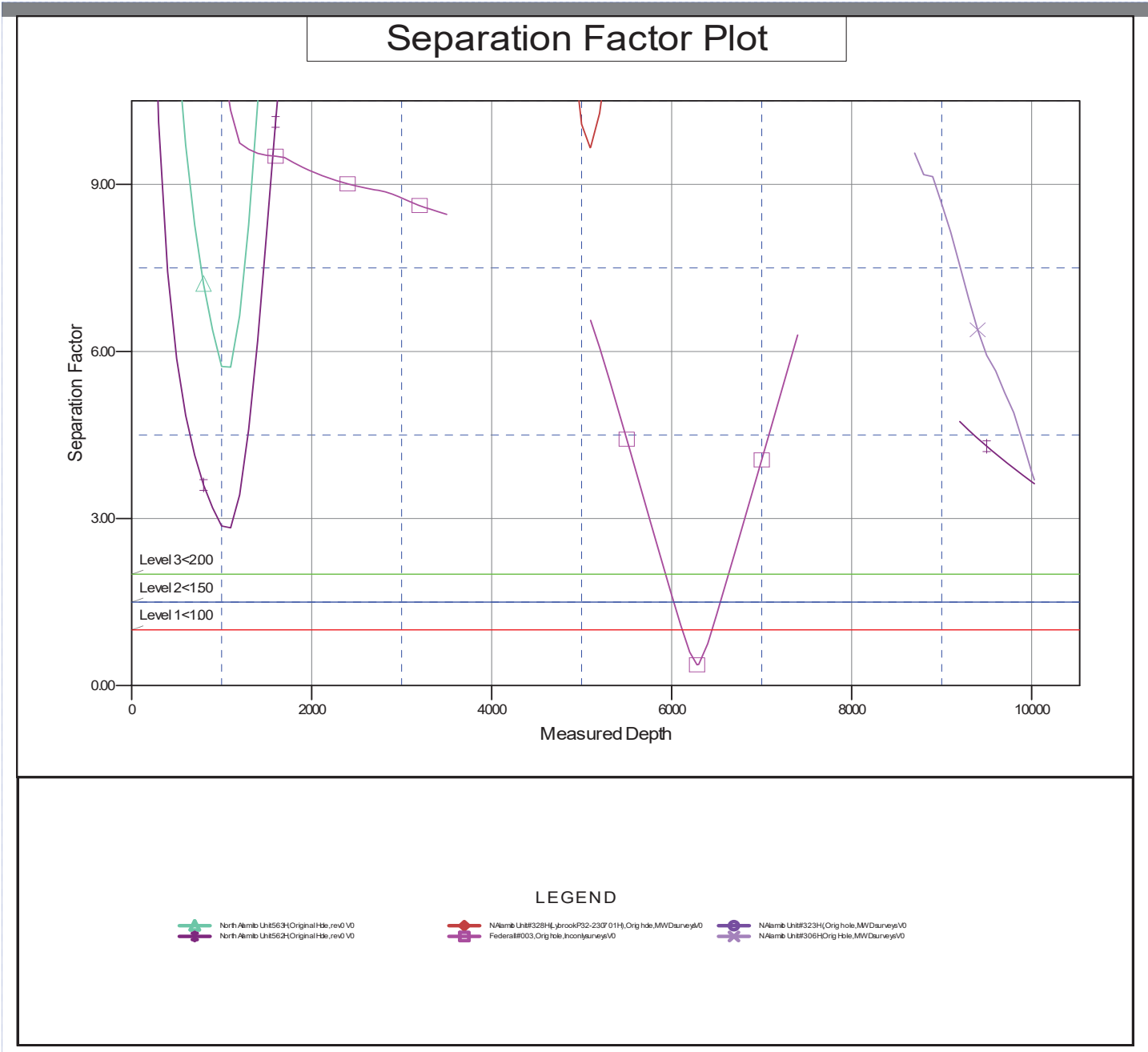

CC - Min centre to center distance or convergent point, SF - min separation factor, ES - min ellipse separation



### Anticollision Report

<b>Company:</b>	Enduring Resources LLC	<b>Local Co-ordinate Reference:</b>	Site North Alamito Unit (560, 562 & 563)
<b>Project:</b>	Sandoval County, New Mexico NAD83 NM C	<b>TVD Reference:</b>	RKB=6876+23.5 @ 6899.50ft
<b>Reference Site:</b>	North Alamito Unit (560, 562 & 563)	<b>MD Reference:</b>	RKB=6876+23.5 @ 6899.50ft
<b>Site Error:</b>	0.00 ft	<b>North Reference:</b>	Grid
<b>Reference Well:</b>	North Alamito Unit 560H	<b>Survey Calculation Method:</b>	Minimum Curvature
<b>Well Error:</b>	0.00 ft	<b>Output errors are at</b>	2.00 sigma
<b>Reference Wellbore</b>	Original Hole	<b>Database:</b>	DT-Jun1425_v17
<b>Reference Design:</b>	rev0	<b>Offset TVD Reference:</b>	Offset Datum

<b>Reference</b>	rev0		
<b>Filter type:</b>	GLOBAL FILTER APPLIED: All wellpaths within 200'+ 100/1000 of reference		
<b>Interpolation Method:</b>	MD Interval 100.00ft	<b>Error Model:</b>	ISCWSA
<b>Depth Range:</b>	Unlimited	<b>Scan Method:</b>	Closest Approach 3D
<b>Results Limited by:</b>	Maximum centre distance of 1,203.04ft	<b>Error Surface:</b>	Ellipsoid Separation
<b>Warning Levels Evaluated at:</b>	2.00 Sigma	<b>Casing Method:</b>	Not applied

<b>Survey Tool Program</b>	<b>Date</b>	8/29/2025		
<b>From (ft)</b>	<b>To (ft)</b>	<b>Survey (Wellbore)</b>	<b>Tool Name</b>	<b>Description</b>
0.00	10,030.35	rev0 (Original Hole)	MWD	OWSG MWD - Standard

Site Name	Reference Measured Depth (ft)	Offset Measured Depth (ft)	Distance Between Centres (ft)	Distance Between Ellipses (ft)	Separation Factor	Warning
<b>Offset Well - Wellbore - Design</b>						
North Alamito Unit (560, 562 & 563)						
North Alamito Unit 562H - Original Hole - rev0	1,000.00	1,000.00	20.06	13.06	2.865	CC, ES
North Alamito Unit 562H - Original Hole - rev0	1,100.00	1,099.95	21.85	14.14	2.832	SF
North Alamito Unit 563H - Original Hole - rev0	1,000.00	1,000.00	40.12	33.12	5.730	CC, ES
North Alamito Unit 563H - Original Hole - rev0	1,100.00	1,098.12	43.98	36.29	5.719	SF

<b>Offset Design:</b>	North Alamito Unit (560, 562 & 563) - North Alamito Unit 562H - Original Hole - rev0										<b>Offset Site Error:</b>	0.00 ft	
<b>Survey Program:</b>	0-MWD										<b>Offset Well Error:</b>	0.00 ft	
Reference Measured Depth (ft)	Vertical Depth (ft)	Offset Measured Depth (ft)	Vertical Depth (ft)	Semi Major Axis Reference (ft)	Offset (ft)	Highside Toolface (°)	Offset Wellbore Centre +N/-S (ft)	+E/-W (ft)	Distance Between Centres (ft)	Between Ellipses (ft)	Minimum Separation (ft)	Separation Factor	Warning
0.00	0.00	0.00	0.00	0.00	0.00	-175.835	-20.01	-1.46	20.06				
100.00	100.00	100.00	100.00	0.27	0.27	-175.835	-20.01	-1.46	20.06	19.51	0.55	36.573	
200.00	200.00	200.00	200.00	0.63	0.63	-175.835	-20.01	-1.46	20.06	18.79	1.27	15.852	
300.00	300.00	300.00	300.00	0.99	0.99	-175.835	-20.01	-1.46	20.06	18.08	1.98	10.119	
400.00	400.00	400.00	400.00	1.35	1.35	-175.835	-20.01	-1.46	20.06	17.36	2.70	7.431	
500.00	500.00	500.00	500.00	1.71	1.71	-175.835	-20.01	-1.46	20.06	16.64	3.42	5.872	
600.00	600.00	600.00	600.00	2.07	2.07	-175.835	-20.01	-1.46	20.06	15.93	4.13	4.853	
700.00	700.00	700.00	700.00	2.43	2.43	-175.835	-20.01	-1.46	20.06	15.21	4.85	4.136	
800.00	800.00	800.00	800.00	2.78	2.78	-175.835	-20.01	-1.46	20.06	14.49	5.57	3.603	
900.00	900.00	900.00	900.00	3.14	3.14	-175.835	-20.01	-1.46	20.06	13.78	6.28	3.192	
1,000.00	1,000.00	1,000.00	1,000.00	3.50	3.50	-175.835	-20.01	-1.46	20.06	13.06	7.00	2.865	CC, ES
1,100.00	1,099.95	1,099.95	1,099.95	3.86	3.86	-135.808	-20.01	-1.46	21.85	14.14	7.72	2.832	SF
1,200.00	1,199.63	1,199.14	1,199.10	4.22	4.20	-141.952	-21.23	-3.72	28.84	20.42	8.42	3.426	
1,300.00	1,298.77	1,297.65	1,297.30	4.58	4.54	-142.822	-24.85	-10.45	41.91	32.80	9.11	4.600	
1,400.00	1,397.08	1,394.93	1,393.76	4.96	4.88	-141.483	-30.78	-21.47	60.83	51.01	9.82	6.197	
1,500.00	1,494.31	1,490.46	1,487.75	5.37	5.23	-139.604	-38.87	-36.48	85.53	74.99	10.53	8.118	
1,600.00	1,590.90	1,584.31	1,579.13	5.81	5.60	-137.459	-48.97	-55.23	114.04	102.77	11.27	10.121	
1,700.00	1,687.50	1,676.54	1,667.83	6.27	6.00	-134.487	-60.96	-77.49	144.71	132.70	12.01	12.047	
1,800.00	1,784.10	1,766.79	1,753.33	6.74	6.43	-131.277	-74.64	-102.90	177.87	165.10	12.77	13.930	
1,900.00	1,880.69	1,854.73	1,835.24	7.22	6.90	-128.096	-89.80	-131.05	213.77	200.24	13.53	15.804	
2,000.00	1,977.29	1,940.08	1,913.25	7.72	7.40	-125.072	-106.21	-161.52	252.59	238.32	14.28	17.692	
2,100.00	2,073.88	2,022.65	1,987.17	8.22	7.94	-122.262	-123.65	-193.88	294.44	279.43	15.01	19.613	
2,200.00	2,170.48	2,100.00	2,054.93	8.73	8.49	-119.757	-141.34	-226.73	339.34	323.66	15.68	21.641	

CC - Min centre to center distance or convergent point, SF - min separation factor, ES - min ellipse separation



Anticollision Report

<b>Company:</b>	Enduring Resources LLC	<b>Local Co-ordinate Reference:</b>	Site North Alamito Unit (560, 562 & 563)
<b>Project:</b>	Sandoval County, New Mexico NAD83 NM C	<b>TVD Reference:</b>	RKB=6876+23.5 @ 6899.50ft
<b>Reference Site:</b>	North Alamito Unit (560, 562 & 563)	<b>MD Reference:</b>	RKB=6876+23.5 @ 6899.50ft
<b>Site Error:</b>	0.00 ft	<b>North Reference:</b>	Grid
<b>Reference Well:</b>	North Alamito Unit 560H	<b>Survey Calculation Method:</b>	Minimum Curvature
<b>Well Error:</b>	0.00 ft	<b>Output errors are at</b>	2.00 sigma
<b>Reference Wellbore</b>	Original Hole	<b>Database:</b>	DT-Jun1425_v17
<b>Reference Design:</b>	rev0	<b>Offset TVD Reference:</b>	Offset Datum

Offset Design: North Alamito Unit (560, 562 & 563) - North Alamito Unit 562H - Original Hole - rev0													Offset Site Error:	0.00 ft		
Survey Program: 0-MWD													Rule Assigned:		Offset Well Error:	0.00 ft
Measured Depth (ft)	Vertical Reference Depth (ft)	Offset		Semi Major Axis		Highside Toolface (°)	Offset Wellbore Centre		Distance		Minimum Separation (ft)	Separation Factor	Warning			
		Measured Depth (ft)	Vertical Reference Depth (ft)	Reference (ft)	Offset (ft)		+N/-S (ft)	+E/-W (ft)	Between Centres (ft)	Between Ellipses (ft)						
2,300.00	2,267.07	2,178.81	2,122.34	9.25	9.12	-117.343	-160.68	-262.65	387.23	370.81	16.42	23.581				
2,400.00	2,363.67	2,252.24	2,183.60	9.77	9.76	-115.223	-179.88	-298.30	438.08	420.99	17.09	25.636				
2,500.00	2,460.27	2,322.54	2,240.74	10.29	10.41	-113.308	-199.30	-334.35	491.76	474.04	17.72	27.752				
2,600.00	2,556.86	2,389.72	2,293.91	10.82	11.08	-111.579	-218.77	-370.51	548.15	529.83	18.32	29.922				
2,700.00	2,653.46	2,453.84	2,343.27	11.35	11.77	-110.018	-238.17	-406.53	607.12	588.23	18.90	32.130				
2,800.00	2,750.05	2,514.95	2,389.02	11.89	12.45	-108.607	-257.39	-442.20	668.53	649.10	19.43	34.407				
2,900.00	2,846.65	2,580.65	2,436.91	12.42	13.23	-107.184	-278.72	-481.80	732.06	711.97	20.09	36.436				
3,000.00	2,943.25	2,655.93	2,491.53	12.96	14.15	-105.772	-303.27	-527.40	796.23	775.26	20.97	37.964				
3,100.00	3,039.84	2,731.20	2,546.15	13.50	15.08	-104.564	-327.83	-573.00	860.65	838.78	21.87	39.360				
3,200.00	3,136.44	2,806.47	2,600.78	14.04	16.03	-103.520	-352.39	-618.59	925.27	902.50	22.77	40.637				
3,300.00	3,233.03	2,881.74	2,655.40	14.58	17.00	-102.609	-376.95	-664.19	990.05	966.37	23.69	41.800				
3,400.00	3,329.63	2,957.01	2,710.03	15.13	17.97	-101.807	-401.50	-709.79	1,054.96	1,030.35	24.61	42.867				
3,500.00	3,426.23	3,032.28	2,764.65	15.67	18.96	-101.097	-426.06	-755.38	1,119.98	1,094.44	25.54	43.848				
3,600.00	3,522.82	3,107.56	2,819.27	16.22	19.95	-100.464	-450.62	-800.98	1,185.09	1,158.61	26.48	44.755				
9,200.00	5,130.65	11,331.12	5,101.34	105.59	147.69	88.481	-1,436.56	3,628.02	1,195.05	942.98	252.07	4.741				
9,300.00	5,131.66	11,429.81	5,102.46	108.11	150.09	88.467	-1,438.58	3,726.68	1,178.90	921.96	256.94	4.588				
9,400.00	5,132.66	11,528.49	5,103.58	110.62	152.50	88.453	-1,440.60	3,825.34	1,162.75	900.93	261.82	4.441				
9,500.00	5,133.67	11,627.18	5,104.69	113.13	154.91	88.438	-1,442.62	3,924.00	1,146.60	879.89	266.70	4.299				
9,600.00	5,134.67	11,725.86	5,105.81	115.65	157.33	88.423	-1,444.65	4,022.66	1,130.44	858.85	271.59	4.162				
9,700.00	5,135.68	11,824.55	5,106.93	118.17	159.75	88.408	-1,446.67	4,121.32	1,114.29	837.81	276.48	4.030				
9,800.00	5,136.68	11,923.24	5,108.05	120.69	162.17	88.392	-1,448.69	4,219.98	1,098.14	816.77	281.37	3.903				
9,900.00	5,137.69	12,021.92	5,109.17	123.21	164.59	88.375	-1,450.71	4,318.64	1,081.99	795.72	286.27	3.780				
10,000.00	5,138.69	12,120.61	5,110.29	125.73	167.02	88.358	-1,452.73	4,417.30	1,065.84	774.67	291.17	3.661				
10,030.35	5,139.00	12,150.57	5,110.63	126.50	167.75	88.353	-1,453.34	4,447.24	1,060.94	768.28	292.66	3.625				

CC - Min centre to center distance or convergent point, SF - min separation factor, ES - min ellipse separation



Anticollision Report

<b>Company:</b>	Enduring Resources LLC	<b>Local Co-ordinate Reference:</b>	Site North Alamito Unit (560, 562 & 563)
<b>Project:</b>	Sandoval County, New Mexico NAD83 NM C	<b>TVD Reference:</b>	RKB=6876+23.5 @ 6899.50ft
<b>Reference Site:</b>	North Alamito Unit (560, 562 & 563)	<b>MD Reference:</b>	RKB=6876+23.5 @ 6899.50ft
<b>Site Error:</b>	0.00 ft	<b>North Reference:</b>	Grid
<b>Reference Well:</b>	North Alamito Unit 560H	<b>Survey Calculation Method:</b>	Minimum Curvature
<b>Well Error:</b>	0.00 ft	<b>Output errors are at</b>	2.00 sigma
<b>Reference Wellbore</b>	Original Hole	<b>Database:</b>	DT-Jun1425_v17
<b>Reference Design:</b>	rev0	<b>Offset TVD Reference:</b>	Offset Datum

Offset Design: North Alamito Unit (560, 562 & 563) - North Alamito Unit 563H - Original Hole - rev0													Offset Site Error:	0.00 ft		
Survey Program: 0-MWD													Rule Assigned:		Offset Well Error:	0.00 ft
Measured Depth (ft)	Vertical Depth (ft)	Offset		Semi Major Axis		Highside Toolface (°)	Offset Wellbore Centre		Distance		Minimum Separation (ft)	Separation Factor	Warning			
		Measured Depth (ft)	Vertical Depth (ft)	Reference (ft)	Offset (ft)		+N/-S (ft)	+E/-W (ft)	Between Centres (ft)	Between Ellipses (ft)						
0.00	0.00	0.00	0.00	0.00	0.00	-175.835	-40.01	-2.91	40.12							
100.00	100.00	100.00	100.00	0.27	0.27	-175.835	-40.01	-2.91	40.12	39.57	0.55	73.147				
200.00	200.00	200.00	200.00	0.63	0.63	-175.835	-40.01	-2.91	40.12	38.85	1.27	31.704				
300.00	300.00	300.00	300.00	0.99	0.99	-175.835	-40.01	-2.91	40.12	38.14	1.98	20.238				
400.00	400.00	400.00	400.00	1.35	1.35	-175.835	-40.01	-2.91	40.12	37.42	2.70	14.862				
500.00	500.00	500.00	500.00	1.71	1.71	-175.835	-40.01	-2.91	40.12	36.70	3.42	11.743				
600.00	600.00	600.00	600.00	2.07	2.07	-175.835	-40.01	-2.91	40.12	35.98	4.13	9.706				
700.00	700.00	700.00	700.00	2.43	2.43	-175.835	-40.01	-2.91	40.12	35.27	4.85	8.272				
800.00	800.00	800.00	800.00	2.78	2.78	-175.835	-40.01	-2.91	40.12	34.55	5.57	7.206				
900.00	900.00	900.00	900.00	3.14	3.14	-175.835	-40.01	-2.91	40.12	33.83	6.28	6.384				
1,000.00	1,000.00	1,000.00	1,000.00	3.50	3.50	-175.835	-40.01	-2.91	40.12	33.12	7.00	5.730	CC, ES			
1,100.00	1,099.95	1,098.12	1,098.08	3.86	3.84	-131.287	-42.02	-4.44	43.98	36.29	7.69	5.719	SF			
1,200.00	1,199.63	1,195.37	1,195.03	4.22	4.16	-132.668	-47.95	-8.97	55.53	47.17	8.36	6.644				
1,300.00	1,298.77	1,290.88	1,289.76	4.58	4.49	-133.926	-57.58	-16.33	74.70	65.68	9.02	8.280				
1,400.00	1,397.08	1,383.89	1,381.31	4.96	4.83	-134.742	-70.57	-26.25	101.27	91.59	9.68	10.460				
1,500.00	1,494.31	1,473.72	1,468.87	5.37	5.18	-135.133	-86.46	-38.39	134.96	124.62	10.34	13.052				
1,600.00	1,590.90	1,560.54	1,552.52	5.81	5.55	-135.491	-104.92	-52.48	173.72	162.73	10.99	15.806				
1,700.00	1,687.50	1,644.75	1,632.57	6.27	5.94	-134.997	-125.69	-68.34	215.62	203.99	11.63	18.543				
1,800.00	1,784.10	1,726.16	1,708.79	6.74	6.35	-134.108	-148.41	-85.70	260.55	248.30	12.26	21.259				
1,900.00	1,880.69	1,800.00	1,776.81	7.22	6.76	-133.115	-171.24	-103.13	308.49	295.69	12.79	24.110				
2,000.00	1,977.29	1,880.06	1,849.25	7.72	7.25	-131.934	-198.33	-123.82	359.21	345.74	13.47	26.660				
2,100.00	2,073.88	1,952.41	1,913.42	8.22	7.74	-130.826	-224.87	-144.08	412.75	398.69	14.06	29.356				
2,200.00	2,170.48	2,021.66	1,973.62	8.73	8.24	-129.756	-252.06	-164.85	468.94	454.31	14.62	32.066				
2,300.00	2,267.07	2,087.84	2,029.96	9.25	8.75	-128.742	-279.65	-185.92	527.65	512.49	15.17	34.788				
2,400.00	2,363.67	2,150.99	2,082.57	9.77	9.28	-127.789	-307.41	-207.12	588.77	573.07	15.69	37.515				
2,500.00	2,460.27	2,200.00	2,122.59	10.29	9.70	-127.064	-329.90	-224.29	652.27	636.27	16.00	40.765				
2,600.00	2,556.86	2,268.56	2,177.32	10.82	10.34	-126.074	-362.71	-249.35	717.65	700.97	16.68	43.034				
2,700.00	2,653.46	2,323.15	2,219.82	11.35	10.87	-125.307	-389.94	-270.14	785.15	768.02	17.13	45.822				
2,800.00	2,750.05	2,375.11	2,259.34	11.89	11.39	-124.596	-416.75	-290.61	854.52	836.95	17.57	48.625				
2,900.00	2,846.65	2,424.54	2,296.07	12.42	11.92	-123.936	-443.03	-310.68	925.65	907.65	17.99	51.446				
3,000.00	2,943.25	2,471.55	2,330.21	12.96	12.43	-123.325	-468.72	-330.30	998.40	980.01	18.39	54.282				
3,100.00	3,039.84	2,500.00	2,350.47	13.50	12.75	-122.962	-484.59	-342.42	1,072.87	1,054.38	18.49	58.010				
3,200.00	3,136.44	2,558.83	2,391.43	14.04	13.44	-122.230	-518.15	-368.05	1,148.39	1,129.25	19.14	59.999				

CC - Min centre to center distance or convergent point, SF - min separation factor, ES - min ellipse separation



Anticollision Report

<b>Company:</b>	Enduring Resources LLC	<b>Local Co-ordinate Reference:</b>	Site North Alamito Unit (560, 562 & 563)
<b>Project:</b>	Sandoval County, New Mexico NAD83 NM C	<b>TVD Reference:</b>	RKB=6876+23.5 @ 6899.50ft
<b>Reference Site:</b>	North Alamito Unit (560, 562 & 563)	<b>MD Reference:</b>	RKB=6876+23.5 @ 6899.50ft
<b>Site Error:</b>	0.00 ft	<b>North Reference:</b>	Grid
<b>Reference Well:</b>	North Alamito Unit 560H	<b>Survey Calculation Method:</b>	Minimum Curvature
<b>Well Error:</b>	0.00 ft	<b>Output errors are at</b>	2.00 sigma
<b>Reference Wellbore</b>	Original Hole	<b>Database:</b>	DT-Jun1425_v17
<b>Reference Design:</b>	rev0	<b>Offset TVD Reference:</b>	Offset Datum

Reference Depths are relative to RKB=6876+23.5 @ 6899.50ft  
 Offset Depths are relative to Offset Datum  
 Central Meridian is -106.25000000

Coordinates are relative to: North Alamito Unit (560, 562 & 563)  
 Coordinate System is US State Plane 1983, New Mexico Central Zone  
 Grid Convergence at Surface is: -0.790°

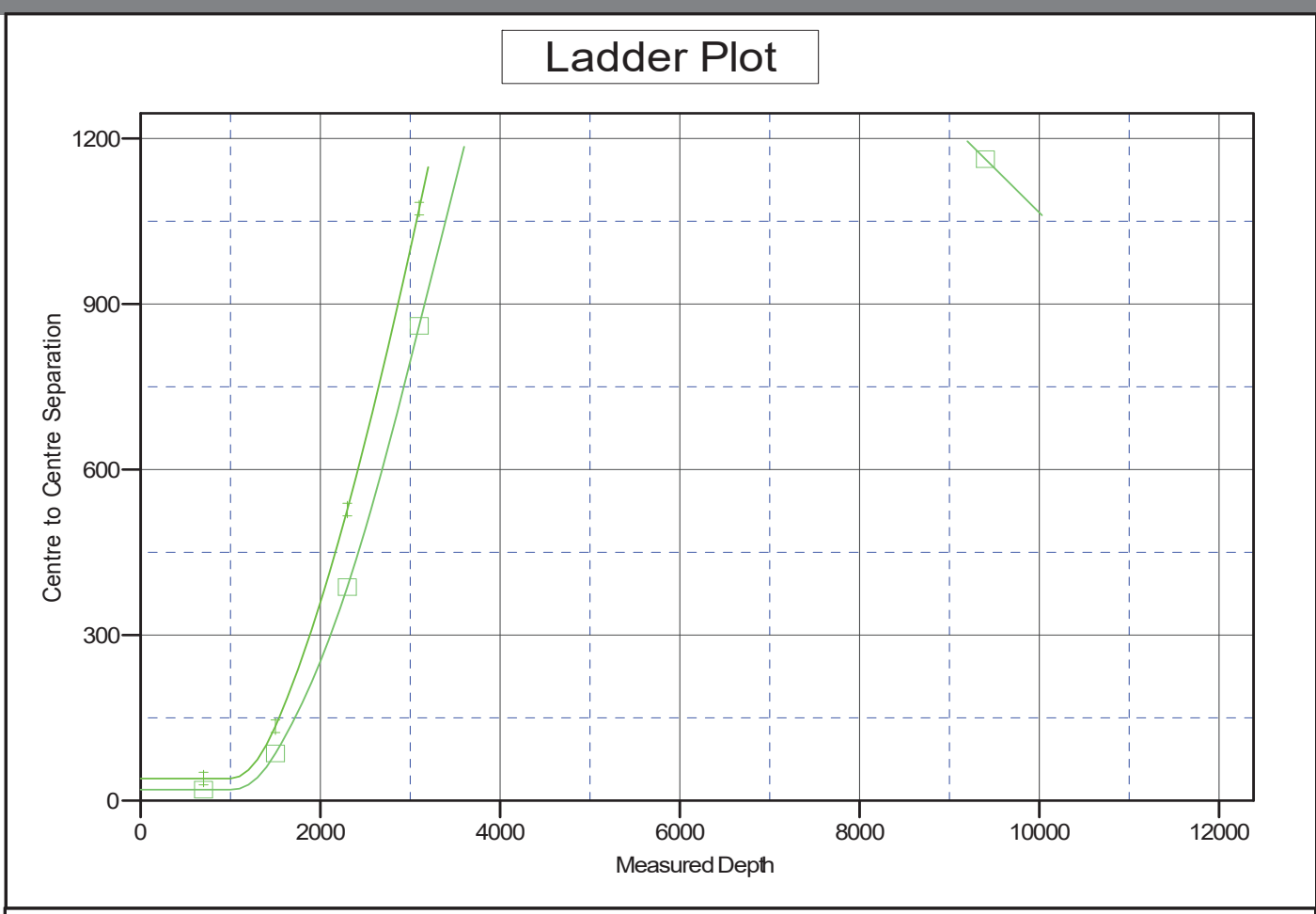

**LEGEND**

	North Alamito Unit 560H Original Hole rev0 V0		North Alamito Unit 562H Original Hole rev0 V0
--	---	--	---

CC - Min centre to center distance or convergent point, SF - min separation factor, ES - min ellipse separation



### Anticollision Report

<b>Company:</b>	Enduring Resources LLC	<b>Local Co-ordinate Reference:</b>	Site North Alamito Unit (560, 562 & 563)
<b>Project:</b>	Sandoval County, New Mexico NAD83 NM C	<b>TVD Reference:</b>	RKB=6876+23.5 @ 6899.50ft
<b>Reference Site:</b>	North Alamito Unit (560, 562 & 563)	<b>MD Reference:</b>	RKB=6876+23.5 @ 6899.50ft
<b>Site Error:</b>	0.00 ft	<b>North Reference:</b>	Grid
<b>Reference Well:</b>	North Alamito Unit 560H	<b>Survey Calculation Method:</b>	Minimum Curvature
<b>Well Error:</b>	0.00 ft	<b>Output errors are at</b>	2.00 sigma
<b>Reference Wellbore</b>	Original Hole	<b>Database:</b>	DT-Jun1425_v17
<b>Reference Design:</b>	rev0	<b>Offset TVD Reference:</b>	Offset Datum

Reference Depths are relative to RKB=6876+23.5 @ 6899.50ft  
 Offset Depths are relative to Offset Datum  
 Central Meridian is -106.2500000

Coordinates are relative to: North Alamito Unit (560, 562 & 563)  
 Coordinate System is US State Plane 1983, New Mexico Central Zone  
 Grid Convergence at Surface is: -0.790°

## Separation Factor Plot

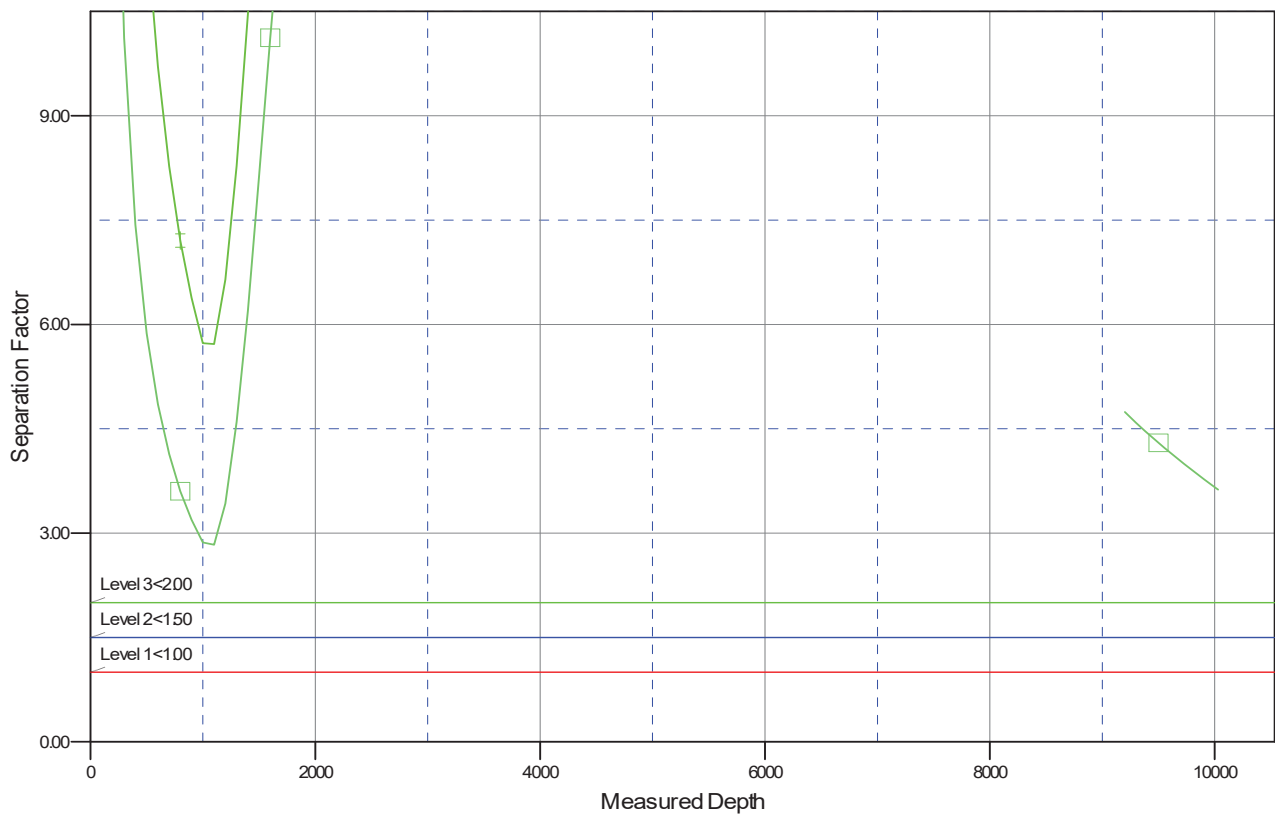

### LEGEND

■ North Alamito Unit 560H Original Hole rev0 V0
 ■ North Alamito Unit 562H Original Hole rev0 V0

CC - Min centre to center distance or convergent point, SF - min separation factor, ES - min ellipse separation



# United States Department of the Interior

BUREAU OF LAND MANAGEMENT  
Farmington District Office  
6251 College Blvd, Suite A  
Farmington, New Mexico 87402



In Reply Refer To:  
3162.3-1(NMF0110)

DJR OPERATING LLC  
#560H N ALAMITO UNIT  
APD ID: 10400107405

## GENERAL REQUIREMENTS FOR OIL AND GAS OPERATIONS ON FEDERAL AND INDIAN LEASES

The following special requirements apply and are effective when **checked**:

- A.  Note all surface/drilling conditions of approval attached.
- B.  The required wait on cement (WOC) time will be a minimum of 500 psi compressive strength at 60 degrees. Blowout preventor (BOP) nipple-up operations may then be initiated
- C.  Test all casing strings below the conductor casing to .22 psi/ft. of casing string length or 1500 psi, whichever is greater, but not to exceed 70% of the minimum internal yield (burst) for a minimum of 30 minutes. If pressure declines more than 10 percent in 30 minutes, corrective action shall be taken.
- D.  Communitization Agreement covering the acreage dedicated to this well must be filed for approval with the Bureau of Land Management, New Mexico State Office, Reservoir Management Group, 301 Dinosaur Trail, Santa Fe, New Mexico 87508.  
The effective date of the agreement must be **prior** to any sales.
- E.  The use of co-flex hose is authorized contingent upon the following:
  - 1. From the BOP to the choke manifold: the co-flex hose must be hobbled on both ends and saddle to prevent whip.
  - 2. From the choke manifold to the discharge tank: the co-flex hoses must be as straight as practical, hobbled on both ends and anchored to prevent whip.
  - 3. The co-flex hose pressure rating must be at least commensurate with approved BOPE.

INTERIOR REGION 7 • UPPER COLORADO BASIN

COLORADO, NEW MEXICO, UTAH, WYOMING

## I. GENERAL

- A. Full compliance with all applicable laws and regulations, with the approved Permit to drill, and with the approved Surface Use and Operations Plan is required. Lessees and/or operators are fully accountable for the actions of their contractors and subcontractors. Failure to comply with these requirements and the filing of required reports will result in strict enforcement pursuant to 43 CFR 3163.1 or 3163.2.
- B. Each well shall have a well sign in legible condition from spud date to final abandonment. The sign should show the operator's name, lease serial number, or unit name, well number, location of the well, and whether lease is Tribal or Allotted, (See 43 CFR 3162.6(b)).
- C. A complete copy of the approved Application for Permit to Drill, along with any conditions of approval, shall be available to authorized personnel at the drill site whenever active drilling operations are under way.
- D. For Wildcat wells only, a drilling operations progress report is to be submitted, to the BLM-Field Office, weekly from the spud date until the well is completed and the Well Completion Report is filed. The report should be on 8-1/2 x 11 inch paper, and each page should identify the well by; operator's name, well number, location and lease number.
- E. As soon as practical, notice is required of all blowouts, fires and accidents involving life-threatening injuries or loss of life. (See NTL-3A).
- F. BOP equipment (except the annular preventer) shall be tested utilizing a test plug to full working pressure for 10 minutes. No bleed-off of pressure is acceptable. (See 43 CFR 3172.6(b)(9)(ii)).
- G. The operator shall have sufficient weighting materials and lost circulation materials on location in the event of a pressure kick or in the event of lost circulation. (See 43 CFR 3172.8(a)).
- H. The flare line(s) discharge shall be located not less than 100 feet from the well head, having straight lines unless turns are targeted with running tees, and shall be positioned downwind of the prevailing wind direction and shall be anchored. The flare system shall have an effective method for ignition. Where noncombustible gas is likely or expected to be vented, the system shall be provided supplemental fuel for ignition and to maintain a continuous flare. (See 43 CFR 3172.8(b)(7)).
- I. Prior approval by the BLM-Authorized Office (Drilling and Production Section) is required for variance from the approved drilling program and before commencing plugging operations, plug back work, casing repair work, corrective cementing operations, or suspending drilling operations indefinitely. Emergency approval may be obtained orally, but such approval is contingent upon filing of a Notice of Intent sundry within three business days. **Any changes to the approved plan or any questions regarding drilling operations should be directed to BLM during regular business hours at 505-564-7600. Emergency program changes after hours should be directed to Virgil Lucero at 505-793-1836.**
- J. **The Inspection and Enforcement Section (I&E), phone number (505-564-7750) is to be notified at least 24 hours in advance of BOP test, spudding, cementing, or plugging operations so that a BLM representative may witness the operations.**

- K. From the time drilling operations are initiated and until drilling operations are completed, a member of the drilling crew or the tool pusher shall maintain rig surveillance at all times, unless the well is secured with blowout preventers or cement plugs.
- L. If for any reason, drilling operations are suspended for more than 90 days, a written notice must be provided to this office outlining your plans for this well.
- M. **Commingling:** No production (oil, gas, and water) from the subject well should start until Sundry Notices (if necessary) granting variances from applicable regulations as related to commingling and off-lease measurement are approved by this office. (See 43 CFR 3173.14)

## **II. REPORTING REQUIREMENTS**

- A. For reporting purposes, all well Sundry notices, well completion and other well actions shall be referenced by the appropriate lease, communitization agreement and/or unit agreement numbers.
- B. The following reports shall be filed with the BLM-Authorized Officer online through AFMSS 2 within 30 days after the work is completed.
  - 1. Provide complete information concerning.
    - a. Setting of each string of casing. Show size and depth of hole, grade and weight of casing, depth set, depth of all cementing tools that are used, amount (in cubic feet) and types of cement used, whether cement circulated to surface and all cement tops in the casing annulus, casing test method and results, and the date work was done. Show spud date on first report submitted.
    - b. Intervals tested, perforated (include size, number and location of perforations), acidized, or fractured; and results obtained. Provide date work was done on well completion report and completion sundry notice.
    - c. Subsequent Report of Abandonment, show the way the well was plugged, including depths where casing was cut and pulled, intervals (by depths) where cement plugs were replaced, and dates of the operations.
  - 2. Well Completion Report will be submitted with 30 days after well has been completed.
    - a. Initial Bottom Hole Pressure (BHP) for the producing formations. Show the BHP on the completion report. The pressure may be: 1) measured with a bottom hole bomb, or; 2) calculated based on shut in surface pressures (minimum seven day buildup) and fluid level shot.
  - 3. Submit a cement evaluation log if cement is not circulated to surface.
- C. Production Startup Notification is required no later than the 5<sup>th</sup> business day after any well begins production on which royalty is due anywhere on a lease site or allocated to a lease site or resumes production in the case of a well which has been off production for more than 90 days. The operator shall notify the Authorized Officer by letter or Sundry Notice, Form 3160-5, or orally to be followed by a letter or Sundry Notice, of the date on which such production has begun or resumed. CFR 43 3162.4-1(c).

### **III. DRILLER'S LOG**

The following shall be entered in the daily driller's log: 1) Blowout preventer pressures tests, including test pressures and results, 2) Blowout preventer tests for proper functioning, 3) Blowout prevention drills conducted, 4) Casing run, including size, grade, weight, and depth set, 5) How pipe was cemented, including amount of cement, type, whether cement circulated to surface, location of cementing tools, etc., 6) Waiting on cement time for each casing string, 7) Casing pressure tests after cementing, including test pressure and results, and 8) Estimated amounts of oil and gas recovered and/or produced during drill stem test.

### **IV. GAS FLARING**

Gas produced from this well may not be vented or flared beyond an initial, authorized test period of **\* Days**, 20 MMCF following its (completion)(recompletion), or flowback has been routed to the production separator, whichever first occurs, without the prior, written approval of the authorized officer in accordance with 43 CFR 3179.81. Should gas be vented or flared without approval beyond the test period authorized above, you may be directed to shut-in the well until the gas can be captured or approval to continue venting or flaring as uneconomic is granted. You shall be required to compensate the lessor for the portion of the gas vented or flared without approval which is determined to have been avoidably lost.

**\*30 days**, unless a longer test period is specifically approved by the authorized officer. The 30-day period will commence upon the beginning of flowback following completion or recompletion.

### **V. SAFETY**

- A. All rig heating stoves are to be of the explosion-proof type.
- B. Rig safety lines are to be installed.
- C. Hard hats and other Personal Protective Equipment (PPE) must be utilized.

### **VI. CHANGE OF PLANS OR ABANDONMENT**

- A. Any changes of plans required to mitigate unanticipated conditions encountered during drilling operations, will require approval as set forth in Section 1.I.
- B. If the well is dry, it is to be plugged in accordance with 43 CFR 3162.3-4, approval of the proposed plugging program is required as set forth in Section 1.I. The report should show the total depth reached, the reason for plugging, and the proposed intervals, by depths, where cement plugs are to be placed, type of plugging mud, etc. A Subsequent Report of Abandonment is required as set forth in Section II.B.1c.
- C. Unless a well has been properly cased and cemented, or properly plugged, the drilling rig must not be moved from the drill site without prior approval from the BLM-Authorized Officer.

### **VII. PHONE NUMBERS**

- A. **For BOPE tests, cementing, and plugging operations the phone number is 505-564-7750 and must be called 24 hours in advance in order that a BLM representative may witness the operations.**

Sante Fe Main Office  
Phone: (505) 476-3441

General Information  
Phone: (505) 629-6116

Online Phone Directory  
<https://www.emnrd.nm.gov/ocd/contact-us>

**State of New Mexico**  
**Energy, Minerals and Natural Resources**  
**Oil Conservation Division**  
**1220 S. St Francis Dr.**  
**Santa Fe, NM 87505**

ACKNOWLEDGMENTS

Action 545083

**ACKNOWLEDGMENTS**

Operator: DJR OPERATING, LLC 200 Energy Court Farmington, NM 87401	OGRID: 371838
	Action Number: 545083
	Action Type: [C-101] BLM - Federal/Indian Land Lease (Form 3160-3)

**ACKNOWLEDGMENTS**

<input checked="" type="checkbox"/>	I hereby certify that no additives containing PFAS chemicals will be added to the completion or recompletion of this well.
-------------------------------------	--

Sante Fe Main Office  
Phone: (505) 476-3441

General Information  
Phone: (505) 629-6116

Online Phone Directory  
<https://www.emnrd.nm.gov/oecd/contact-us>

**State of New Mexico**  
**Energy, Minerals and Natural Resources**  
**Oil Conservation Division**  
**1220 S. St Francis Dr.**  
**Santa Fe, NM 87505**

CONDITIONS

Action 545083

**CONDITIONS**

Operator: DJR OPERATING, LLC 200 Energy Court Farmington, NM 87401	OGRID: 371838
	Action Number: 545083
	Action Type: [C-101] BLM - Federal/Indian Land Lease (Form 3160-3)

**CONDITIONS**

Created By	Condition	Condition Date
scrues76	Cement is required to circulate on both surface and intermediate1 strings of casing.	1/21/2026
scrues76	If cement does not circulate on any string, a Cement Bond Log (CBL) is required for that string of casing.	1/21/2026
ward.rikala	Notify the OCD 24 hours prior to casing & cement.	3/30/2026
ward.rikala	File As Drilled C-102 and a directional Survey with C-104 completion packet.	3/30/2026
ward.rikala	Once the well is spud, to prevent ground water contamination through whole or partial conduits from the surface, the operator shall drill without interruption through the fresh water zone or zones and shall immediately set in cement the water protection string.	3/30/2026
ward.rikala	Oil base muds are not to be used until fresh water zones are cased and cemented providing isolation from the oil or diesel. This includes synthetic oils. Oil based mud, drilling fluids and solids must be contained in a steel closed loop system.	3/30/2026
ward.rikala	If the method of isolation was not by circulation, a CBL must be performed; if strata isolation is not achieved, then remediation will be required before further operations.	3/30/2026