

Sante Fe Main Office
Phone: (505) 476-3441

General Information
Phone: (505) 629-6116

Online Phone Directory
<https://www.emnrd.nm.gov/ocd/contact-us>

State of New Mexico
Energy, Minerals and Natural Resources
Oil Conservation Division
1220 S. St Francis Dr.
Santa Fe, NM 87505

Form C-101
August 1, 2011
Permit 411893

APPLICATION FOR PERMIT TO DRILL, RE-ENTER, DEEPEN, PLUGBACK, OR ADD A ZONE

1. Operator Name and Address EOG RESOURCES INC 5509 Champions Drive Midland, TX 79706		2. OGRID Number 7377
4. Property Code 339048		3. API Number 30-015-58038
5. Property Name LAVASH 2 STATE COM		6. Well No. 703H

7. Surface Location

UL - Lot M	Section 2	Township 26S	Range 28E	Lot Idn M	Feet From 940	N/S Line S	Feet From 844	E/W Line W	County Eddy
---------------	--------------	-----------------	--------------	--------------	------------------	---------------	------------------	---------------	----------------

8. Proposed Bottom Hole Location

UL - Lot C	Section 35	Township 25S	Range 28E	Lot Idn C	Feet From 100	N/S Line N	Feet From 1710	E/W Line W	County Eddy
---------------	---------------	-----------------	--------------	--------------	------------------	---------------	-------------------	---------------	----------------

9. Pool Information

PURPLE SAGE;WOLFCAMP (GAS)	98220
----------------------------	-------

Additional Well Information

11. Work Type New Well	12. Well Type GAS	13. Cable/Rotary	14. Lease Type State	15. Ground Level Elevation 2949
16. Multiple N	17. Proposed Depth 19858	18. Formation Wolfcamp	19. Contractor	20. Spud Date 4/30/2026
Depth to Ground water		Distance from nearest fresh water well		Distance to nearest surface water

We will be using a closed-loop system in lieu of lined pits

21. Proposed Casing and Cement Program

Type	Hole Size	Casing Size	Casing Weight/ft	Setting Depth	Sacks of Cement	Estimated TOC
Surf	13	10.75	40.5	2600	670	0
Int1	9.875	8.625	32	9171	1650	0
Prod	7.875	6	22.3	9271	2570	8548
Prod	6.75	5.5	20	19858	2570	8548

Casing/Cement Program: Additional Comments

--

22. Proposed Blowout Prevention Program

Type Double Ram	Working Pressure 5000	Test Pressure 3000	Manufacturer
--------------------	--------------------------	-----------------------	--------------

23. I hereby certify that the information given above is true and complete to the best of my knowledge and belief. I hereby certify that no additives containing PFAS chemicals will be added to the completion or recompletion of this well. I further certify I have complied with 19.15.14.9 (A) NMAC <input checked="" type="checkbox"/> and/or 19.15.14.9 (B) NMAC <input checked="" type="checkbox"/> , if applicable. Signature:	OIL CONSERVATION DIVISION	
Printed Name: Electronically filed by Kristina Agee Title: Senior Regulatory Administrator Email Address: Kristina_agee@egoresources.com Date: 3/23/2026	Approved By: Jeffrey Harrison Title: Petroleum Specialist III Approved Date: 4/6/2026 Conditions of Approval Attached	Expiration Date: 4/6/2028
Phone: 432-686-6996		

<p>C-102</p> <p>Submit Electronically Via OCD Permitting</p>	<p>State of New Mexico Energy, Minerals & Natural Resources Department OIL CONSERVATION DIVISION</p>	<p>Revised July 9, 2024</p> <p>Submittal Type:</p> <p><input checked="" type="checkbox"/> Initial Submittal</p> <p><input type="checkbox"/> Amended Report</p> <p><input type="checkbox"/> As Drilled</p>
---	---	---

Property Name and Well Number

LAVASH 2 STATE COM 703H

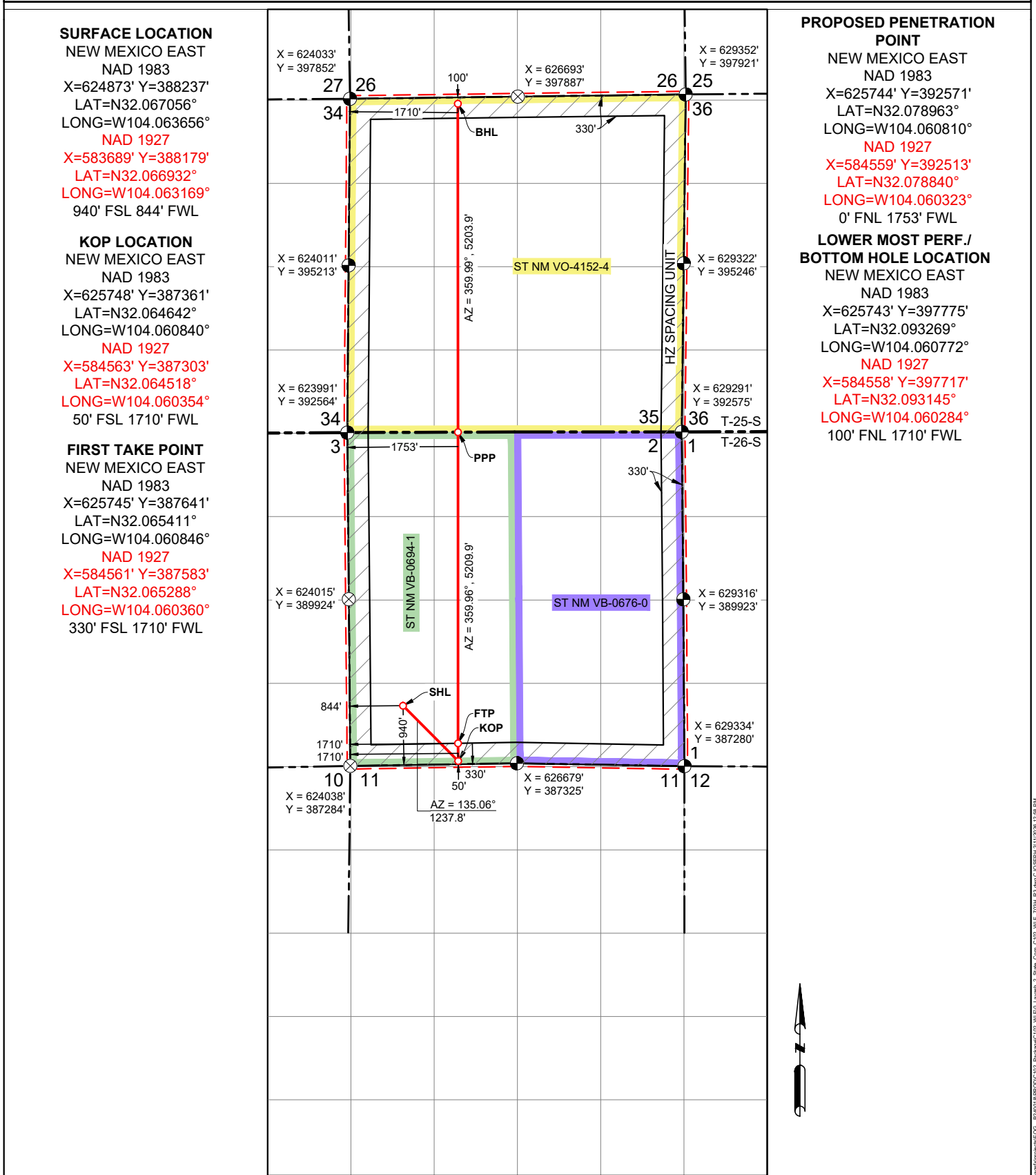

SURFACE LOCATION

NEW MEXICO EAST
NAD 1983
X=624873' Y=388237'
LAT=N32.067056°
LONG=W104.063656°
NAD 1927
X=583689' Y=388179'
LAT=N32.066932°
LONG=W104.063169°
940' FSL 844' FWL

KOP LOCATION

NEW MEXICO EAST
NAD 1983
X=625748' Y=387361'
LAT=N32.064642°
LONG=W104.060840°
NAD 1927
X=584563' Y=387303'
LAT=N32.064518°
LONG=W104.060354°
50' FSL 1710' FWL

FIRST TAKE POINT

NEW MEXICO EAST
NAD 1983
X=625745' Y=387641'
LAT=N32.065411°
LONG=W104.060846°
NAD 1927
X=584561' Y=387583'
LAT=N32.065288°
LONG=W104.060360°
330' FSL 1710' FWL

PROPOSED PENETRATION POINT

NEW MEXICO EAST
NAD 1983
X=625744' Y=392571'
LAT=N32.078963°
LONG=W104.060810°
NAD 1927
X=584559' Y=392513'
LAT=N32.078840°
LONG=W104.060323°
0' FNL 1753' FWL

LOWER MOST PERF./ BOTTOM HOLE LOCATION

NEW MEXICO EAST
NAD 1983
X=625743' Y=397775'
LAT=N32.093269°
LONG=W104.060772°
NAD 1927
X=584558' Y=397717'
LAT=N32.093145°
LONG=W104.060284°
100' FNL 1710' FWL

EXHIBIT 2B PAD LAYOUT

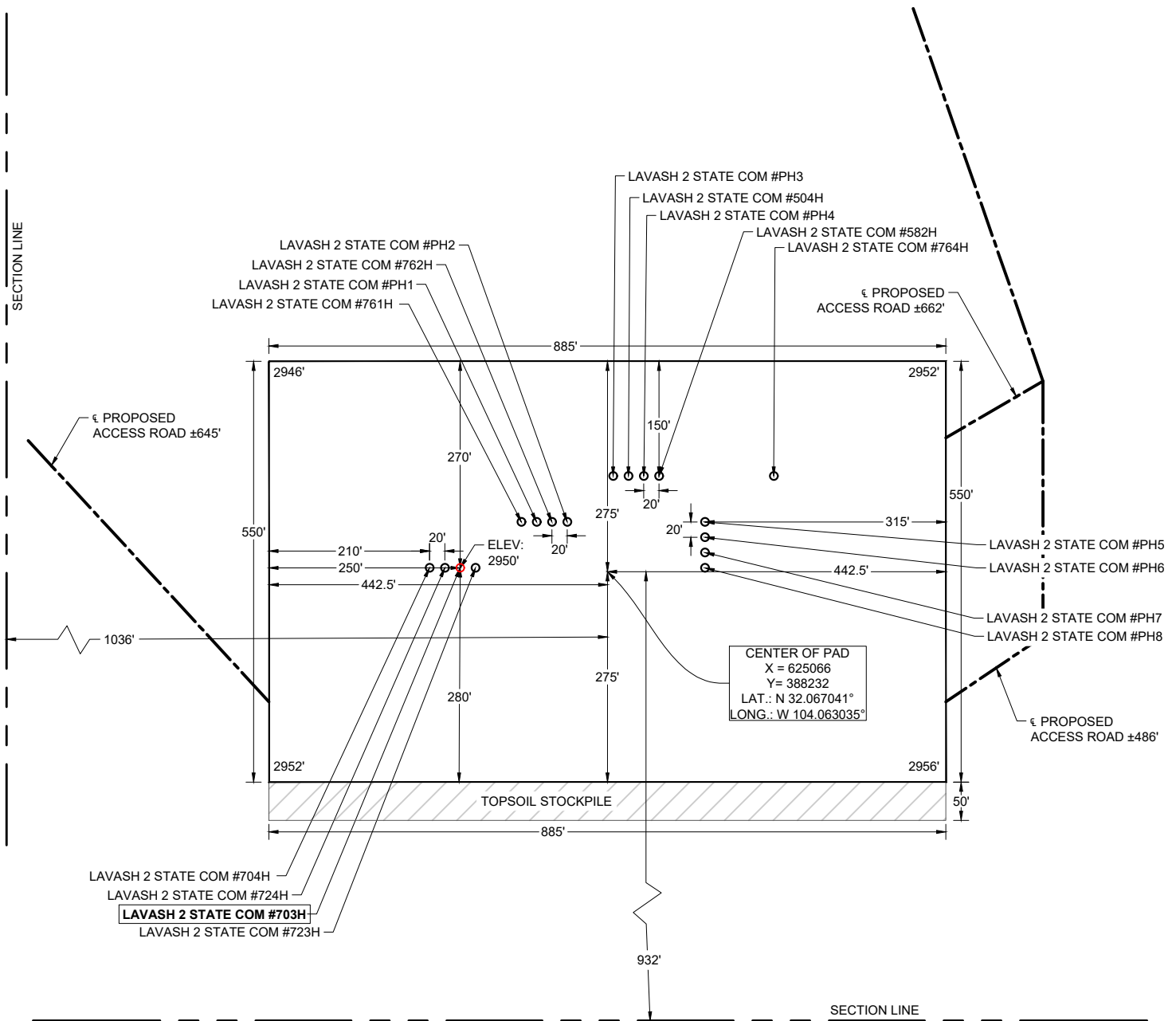

LEASE NAME & WELL NO.: LAVASH 2 STATE COM #703H
 LATITUDE: N 32.067056° LONG: W 104.063656° ELEVATION: 2950'
 SECTION: 2 TWP: 26 S RGE: 28 E SURVEY: N.M.P.M.
 COUNTY: EDDY STATE: NM
 DESCRIPTION: CENTER OF PAD IS 932' FSL & 1036' FWL

LEGEND

= PROPOSED ACCESS ROAD
 = SECTION LINE



JOB No.: B24.EOG.0018

ALL BEARINGS, DISTANCES, AND COORDINATE VALUES CONTAINED HEREIN ARE GRID BASED UPON THE FOLLOWING COORDINATE SYSTEM: NAD83 NEW MEXICO STATE PLANE, EAST ZONE, U.S. SURVEY FEET.

DISCLAIMER:
 THIS PLOT DOES NOT REPRESENT A MONUMENTED LAND SURVEY AND SHOULD NOT BE RELIED UPON TO DETERMINE BOUNDARY LINES, PROPERTY OWNERSHIP OR OTHER PROPERTY INTERESTS.

SCALE: 1" = 200'

ASCENT
 GEOMATICS SOLUTIONS
 Ascent Geomatics Solutions
 8620 Wolff Ct.
 Suite 200
 Westminster, CO 80031
 Office: (303) 928-7128
www.AscentGeomatics.com

I hereby attest that written notification was sent to all affected parties on **February 17, 2026**, notifying them of the proposed overlapping spacing unit and advising that they were required to submit a written **Statement of Objection** to the proposing operator within **twenty (20) days** of the date the notice was sent.

No statements of objection were received within the prescribed timeframe.

Kayla McConnell

A handwritten signature in cursive script that reads "Kayla McConnell".

Regulatory Specialist

EOG Resources Inc.

Sante Fe Main Office
Phone: (505) 476-3441

General Information
Phone: (505) 629-6116

Online Phone Directory
<https://www.emnrd.nm.gov/ocd/contact-us>

State of New Mexico
Energy, Minerals and Natural Resources
Oil Conservation Division
1220 S. St Francis Dr.
Santa Fe, NM 87505

Form APD Comments

Permit 411893

PERMIT COMMENTS

Operator Name and Address: EOG RESOURCES INC [7377] 5509 Champions Drive Midland, TX 79706	API Number: 30-015-58038
	Well: LAVASH 2 STATE COM #703H

Created By	Comment	Comment Date
jeffrey.harrison	Submitted as infill to Lavash 2 State Com 723H.	4/6/2026

Sante Fe Main Office
Phone: (505) 476-3441

General Information
Phone: (505) 629-6116

Online Phone Directory
<https://www.emnrd.nm.gov/ocd/contact-us>

**State of New Mexico
Energy, Minerals and Natural Resources
Oil Conservation Division
1220 S. St Francis Dr.
Santa Fe, NM 87505**

Form APD Conditions

Permit 411893

PERMIT CONDITIONS OF APPROVAL

Operator Name and Address: EOG RESOURCES INC [7377] 5509 Champions Drive Midland, TX 79706	API Number: 30-015-58038
	Well: LAVASH 2 STATE COM #703H

OCD Reviewer	Condition
jeffrey.harrison	Administrative order required for non-standard location prior to production.
jeffrey.harrison	All logs run on the well must be submitted to NMOCD.
jeffrey.harrison	No additives containing PFAS chemicals will be added to the drilling fluids or completion fluids used during drilling, completions, or recompletions operations.
jeffrey.harrison	NSP required if not included in an existing order or not an infill to an appropriate defining well in the same pool and spacing unit.
jeffrey.harrison	Cement is required to circulate on both surface and intermediate1 strings of casing.
jeffrey.harrison	If the method of isolation was not by circulation, a CBL must be performed; if strata isolation is not achieved, then remediation will be required before further operations.
jeffrey.harrison	File As Drilled C-102 and a directional Survey with C-104 completion packet.
jeffrey.harrison	Notify the OCD 24 hours prior to casing & cement.
jeffrey.harrison	A [C-103] Sub. Drilling (C-103N) is required within (10) days of spud.
jeffrey.harrison	Oil base muds are not to be used until fresh water zones are cased and cemented providing isolation from the oil or diesel. This includes synthetic oils. Oil based mud, drilling fluids and solids must be contained in a steel closed loop system.
jeffrey.harrison	Once the well is spud, to prevent ground water contamination through whole or partial conduits from the surface, the operator shall drill without interruption through the fresh water zone or zones and shall immediately set in cement the water protection string.



EOG Batch Casing

Pad Name: Lavash 2 State Com Deep

SHL: Section 2, Township 26-S, Range 28-E, EDDY County, NM

Well Name	API #	Surface		Intermediate		Production	
		MD	TVD	MD	TVD	MD	TVD
Lavash 2 State Com #701H	30-015-*****	2,600	2,600	9,329	9,154	20,063	9,631
Lavash 2 State Com #702H	30-015-*****	2,600	2,600	9,189	9,126	19,883	9,603
Lavash 2 State Com #703H	30-015-*****	2,600	2,600	9,171	9,048	19,858	9,525
Lavash 2 State Com #704H	30-015-*****	2,600	2,600	9,096	9,015	19,787	9,492
Lavash 2 State Com #721H	30-015-*****	2,600	2,600	9,679	9,358	20,430	9,835
Lavash 2 State Com #722H	30-015-*****	2,600	2,600	9,419	9,334	20,134	9,811
Lavash 2 State Com #723H	30-015-*****	2,600	2,600	9,509	9,259	20,193	9,736
Lavash 2 State Com #724H	30-015-*****	2,600	2,600	9,294	9,227	19,982	9,704





Master Variance Document

—

Table of Contents

- [BOPE Break Test \(3/25/2025\)](#)
- [Offline Surface/Intermediate Cement \(8/15/2023\)](#)
- [Intermediate Bradenhead Cement \(Deep Targets\) \(8/15/2023\)](#)
- [Wolfcamp Intermediate Casing Setpoint \(6/26/2024\)](#)
- [Offline Production Cement \(11/12/2024\)](#)
- [Production Bradenhead Cement \(8/9/2024\)](#)
- [Salt Section Annular Clearance \(11/8/2022\)](#)



BOPE Break Test Variance

—

EOG BOPE Break Test Variance (Intervals 5M MASP or less)

EOG Resources Inc. (EOG) respectfully requests a variance from the minimum standards for well control equipment testing of ECFR Title 43 Part 3172.6(b)(9)(iv) to allow a testing schedule of the blow out preventer (BOP) and blow out prevention equipment (BOPE) along with Batch Drilling & Offline cement operations to include the following:

- Full BOPE test at first installation on the pad.
- Full BOPE test every 21 days.
- Break-test only available for the Base of the Wolfcamp or shallower
 - If anything out of the ordinary is observed during drilling, tripping or casing running operations in the production hole section, break testing will not be performed in the subsequent well's production hole section.
 - Furthermore, break testing in the production hole section will not be performed if offset frac operations are observed within 1 mile and within the same producing horizon.
- Each rig requesting the break-test variance is capable of picking up the BOP without damaging components using winches, following API Standard 53, Well Control Equipment Systems for Drilling Wells (Fifth edition, December 2018, Annex C. Table C.4) which recognizes break testing as an acceptable practice.
- Function tests will be performed on the following BOP elements:
 - Annular → during each full BOPE test and at least weekly
 - Pipe Rams → Every trip and on trip ins where FIT required
 - Blind Rams → Every trip
- Break testing BOP and BOPE coupled with batch drilling operations and option to offline cement and/or remediate (if needed) any surface, intermediate or production sections, according to attached offline cementing support documentation.
- After the well section is secured, the BOP will be disconnected from the wellhead and walked with the rig to another well on the pad.
- TA cap will also be installed per Wellhead vendor procedure and pressure inside the casing will be monitored via the valve on the TA cap as per standard batch drilling ops.

Break Test Diagram (Test Joint)

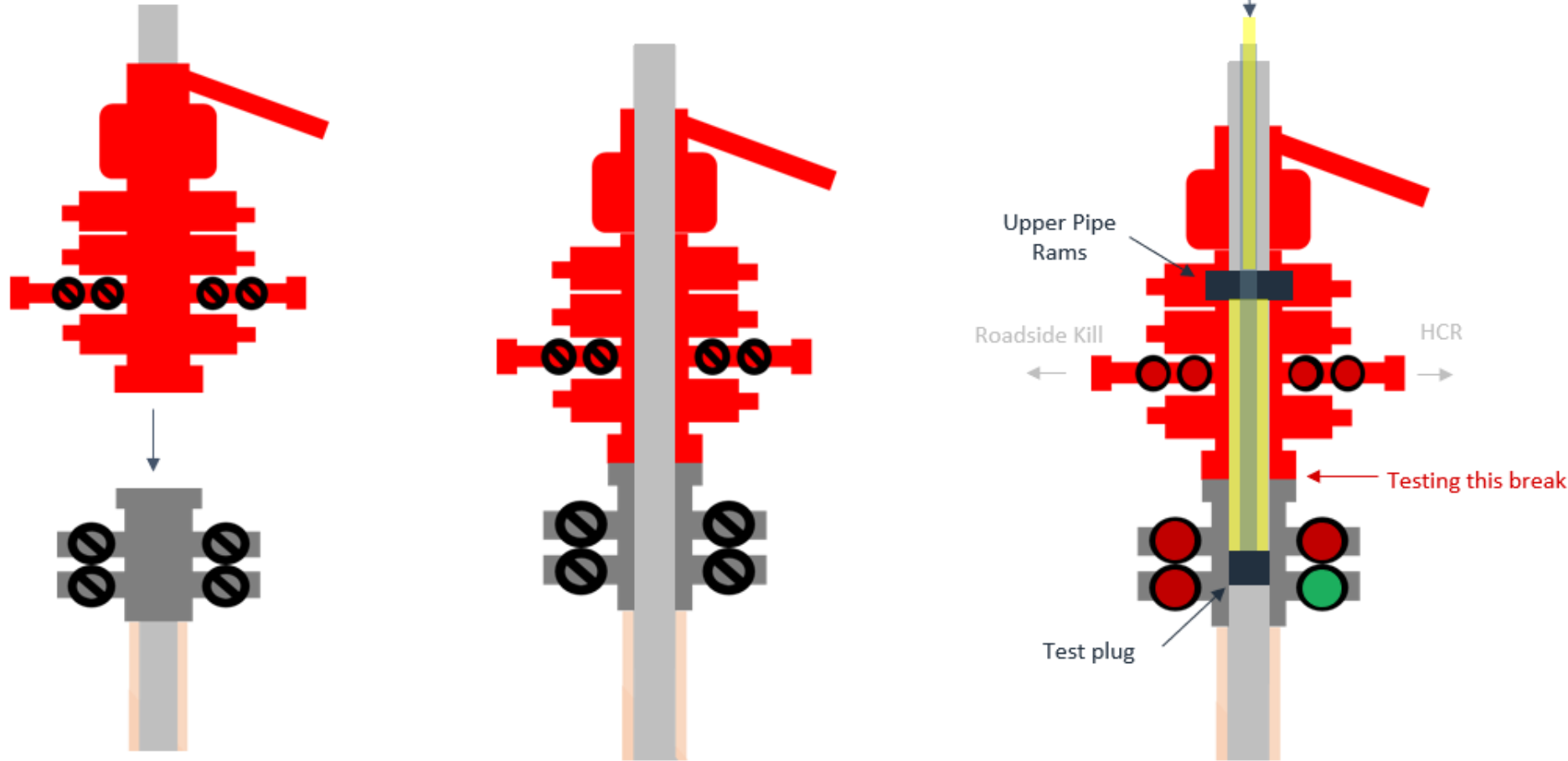

Steps

1. Set plug in with test joint wellhead (lower barrier)
2. Close Upper Pipe Rams (upper barrier)
3. Close roadside kill
4. Close HCR
5. Open wellhead valves below test plug to ensure if leak past test plug, pressure won't be applied to wellbore
6. Tie BOP testers high pressure line to top of test joint
7. Pressure up to test break
8. Bleed test pressure from BOP testing unit



Offline Surface + Intermediate Variance

—

Offline Surface + Intermediate Cement

Cement Program

1. No changes to the cement program will take place for offline cementing.

Summarized Operational Procedure for Intermediate Casing

1. Run casing as per normal operations. While running casing, conduct negative pressure test and confirm integrity of the float equipment back pressure valves.
 - a. Float equipment is equipped with two back pressure valves rated to a minimum of 5,000 psi.
2. Land production casing on mandrel hanger through BOP.
 - a. If casing is unable to be landed with a mandrel hanger, then the **casing will be cemented online.**
3. Break circulation and confirm no restrictions.
 - a. Ensure no blockage of float equipment and appropriate annular returns.
 - b. Perform flow check to confirm well is static.
4. Set pack-off
 - a. If utilizing a fluted/ported mandrel hanger, ensure well is static on the annulus and inside the casing by filling the pipe with kill weight fluid, remove landing joint, and set annular packoff through BOP. Pressure test to 5,000 psi for 10 min.
 - b. If utilizing a solid mandrel hanger, ensure well is static on the annulus and inside the casing by filling the pipe with kill weight fluid. Pressure test seals to 5,000 psi for 10 min. Remove landing joint through BOP.
5. After confirmation of both annular barriers and the two casing barriers, install TA plug and pressure test to 5,000 psi for 10 min. Notify the BLM with intent to proceed with nipple down and offline cementing.
 - a. Minimum 4 hrs notice.
6. With the well secured and BLM notified, nipple down BOP and secure on hydraulic carrier or cradle.
 - a. **Note, if any of the barriers fail to test, the BOP stack will not be nipped down until after the cement job has concluded and both lead and tail slurry have reached 500 psi.**
7. Skid/Walk rig off current well.
8. Confirm well is static before removing TA Plug.
 - a. Cementing operations will not proceed until well is under control. (If well is not static, notify BLM and proceed to kill)
 - b. Casing outlet valves will provide access to both the casing ID and annulus. Rig or third party pump truck will kill well prior to cementing.
 - c. Well control plan can be seen in Section B, Well Control Procedures.
 - d. If need be, rig can be moved back over well and BOP nipped back up for any further remediation.

Offline Surface + Intermediate Cement

- e. Diagram for rig positioning relative to offline cementing can be seen in Figure 4.
9. Rig up return lines to take returns from wellhead to pits and rig choke.
 - a. Test all connections and lines from wellhead to choke manifold to 5,000 psi high for 10 min.
 - b. If either test fails, perform corrections and retest before proceeding.
 - c. Return line schematics can be seen in Figure 3.
10. Remove TA Plug from the casing.
11. Install offline cement tool.
 - a. Current offline cement tool schematics can be seen in Figure 1 (Cameron) and Figure 2 (Cactus).
12. Rig up cement head and cementing lines.
 - a. Pressure test cement lines against cement head to 80% of casing burst for 10 min.
13. Break circulation on well to confirm no restrictions.
 - a. If gas is present on circulation, well will be shut in and returns rerouted through gas buster.
 - b. Max anticipated time before circulating with cement truck is 6 hrs.
14. Pump cement job as per plan.
 - a. At plug bump, test casing to 0.22 psi/ft or 1500 psi, whichever is greater.
 - b. If plug does not bump on calculated, shut down and wait 8 hrs or 500 psi compressive strength, whichever is greater before testing casing.
15. Confirm well is static and floats are holding after cement job.
 - a. With floats holding and backside static:
 - i. Remove cement head.
 - b. If floats are leaking:
 - i. Shut-in well and WOC (Wait on Cement) until tail slurry reaches 500 psi compressive strength and the casing is static prior to removing cement head.
 - c. If there is flow on the backside:
 - i. Shut in well and WOC until tail slurry reaches 500 psi compressive strength. Ensure that the casing is static prior to removing cement head.
16. Remove offline cement tool.
17. Install night cap with pressure gauge for monitoring.
18. Test night cap to 5,000 psi for 10 min.

Offline Surface + Intermediate Cement

Example Well Control Plan Content

A. Well Control Component Table

The table below, which covers the cementing of the **5M MASP (Maximum Allowable Surface Pressure) portion of the well**, outlines the well control component rating in use. This table, combined with the mud program, documents that two barriers to flow can be maintained at all times, independent of the BOP nipped up to the wellhead.

Intermediate hole section, 5M requirement

Component	RWP
Pack-off	10M
Casing Wellhead Valves	10M
Annular Wellhead Valves	5M
TA Plug	10M
Float Valves	5M
2" 1502 Lo-Torque Valves	15M

B. Well Control Procedures

Well control procedures are specific to the rig equipment and the operation at the time the kick occurs. Below are the minimal high-level tasks prescribed to assure a proper shut-in while circulating and cementing through the Offline Cement Adapter.

General Procedure While Circulating

1. Sound alarm (alert crew).
2. Shut down pumps.
3. Shut-in Well (close valves to rig pits and open valve to rig choke line. Rig choke will already be in the closed position).
4. Confirm shut-in.
5. Notify tool pusher/company representative.

Offline Surface + Intermediate Cement

Example Well Control Plan Content

A. Well Control Component Table

The table below, which covers the cementing of the **5M MASP (Maximum Allowable Surface Pressure) portion of the well**, outlines the well control component rating in use. This table, combined with the mud program, documents that two barriers to flow can be maintained at all times, independent of the BOP nipped up to the wellhead.

Intermediate hole section, 5M requirement

Component	RWP
Pack-off	10M
Casing Wellhead Valves	10M
Annular Wellhead Valves	5M
TA Plug	10M
Float Valves	5M
2" 1502 Lo-Torque Valves	15M

B. Well Control Procedures

Well control procedures are specific to the rig equipment and the operation at the time the kick occurs. Below are the minimal high-level tasks prescribed to assure a proper shut-in while circulating and cementing through the Offline Cement Adapter.

General Procedure While Circulating

1. Sound alarm (alert crew).
2. Shut down pumps.
3. Shut-in Well (close valves to rig pits and open valve to rig choke line. Rig choke will already be in the closed position).
4. Confirm shut-in.
5. Notify tool pusher/company representative.

Offline Surface + Intermediate Cement

6. Read and record the following:
 - a. SICP (Shut in Casing Pressure) and AP (Annular Pressure)
 - b. Pit gain
 - c. Time
 - d. Regroup and identify forward plan to continue circulating out kick via rig choke and mud/gas separator. Circulate and adjust mud density as needed to control well.

General Procedure While Cementing

1. Sound alarm (alert crew).
2. Shut down pumps.
3. Shut-in Well (close valves to rig pits and open valve to rig choke line. Rig choke will already be in the closed position).
4. Confirm shut-in.
5. Notify tool pusher/company representative.
6. Open rig choke and begin pumping again taking returns through choke manifold and mud/gas separator.
7. Continue to place cement until plug bumps.
8. At plug bump close rig choke and cement head.
9. Read and record the following
 - a. SICP and AP
 - b. Pit gain
 - c. Time
 - d. Shut-in annulus valves on wellhead

General Procedure After Cementing

1. Sound alarm (alert crew).
2. Shut-in Well (close valves to rig pits and open valve to rig choke line. Rig choke will already be in the closed position).
3. Confirm shut-in.
4. Notify tool pusher/company representative.
5. Read and record the following:
 - a. SICP and AP
 - b. Pit gain
 - c. Time
 - d. Shut-in annulus valves on wellhead

Offline Surface + Intermediate Cement

Figure 1: Cameron TA Plug and Offline Adapter Schematic

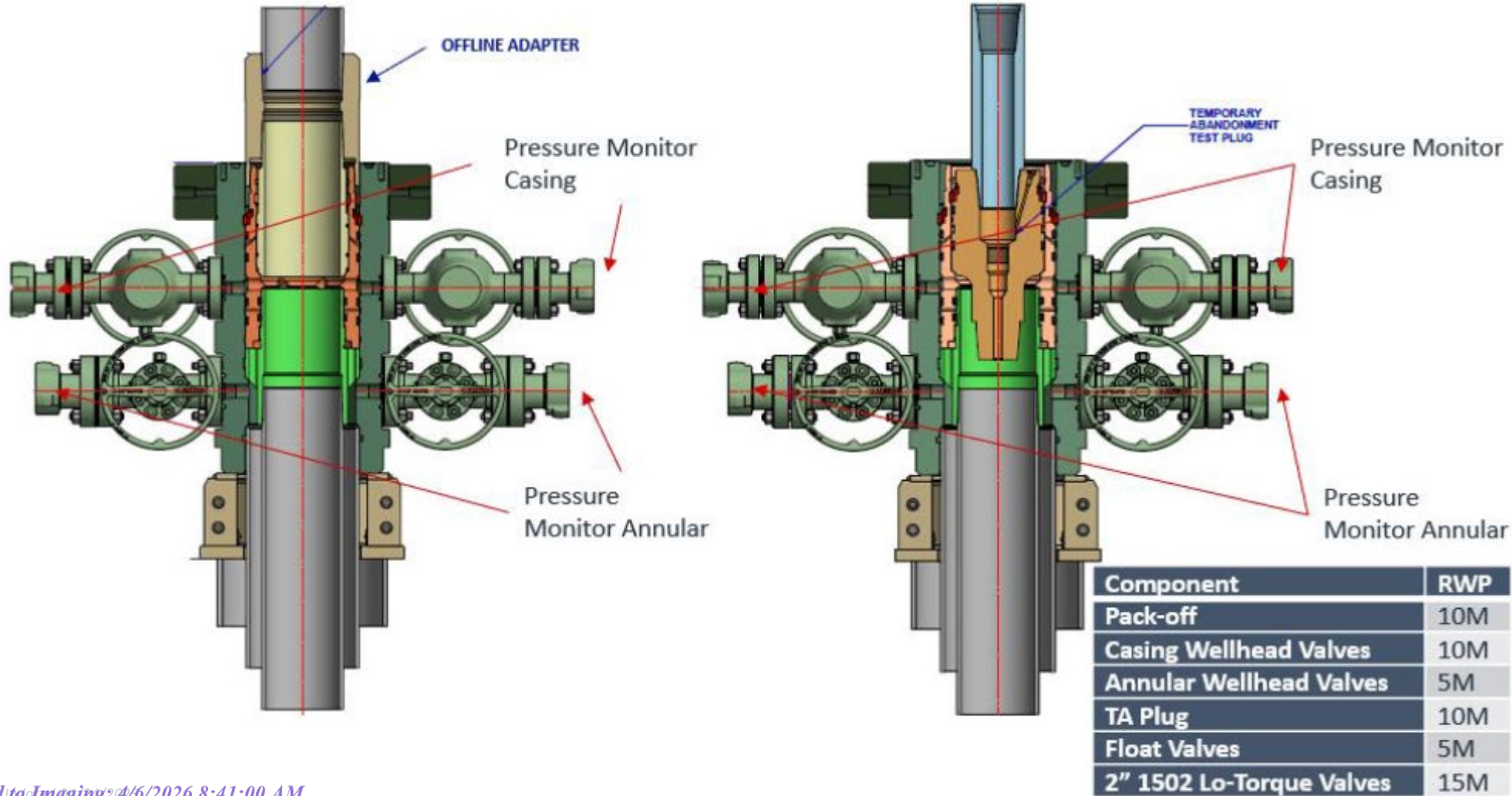

Offline Surface + Intermediate Cement

Figure 2: Cactus TA Plug and Offline Adapter Schematic

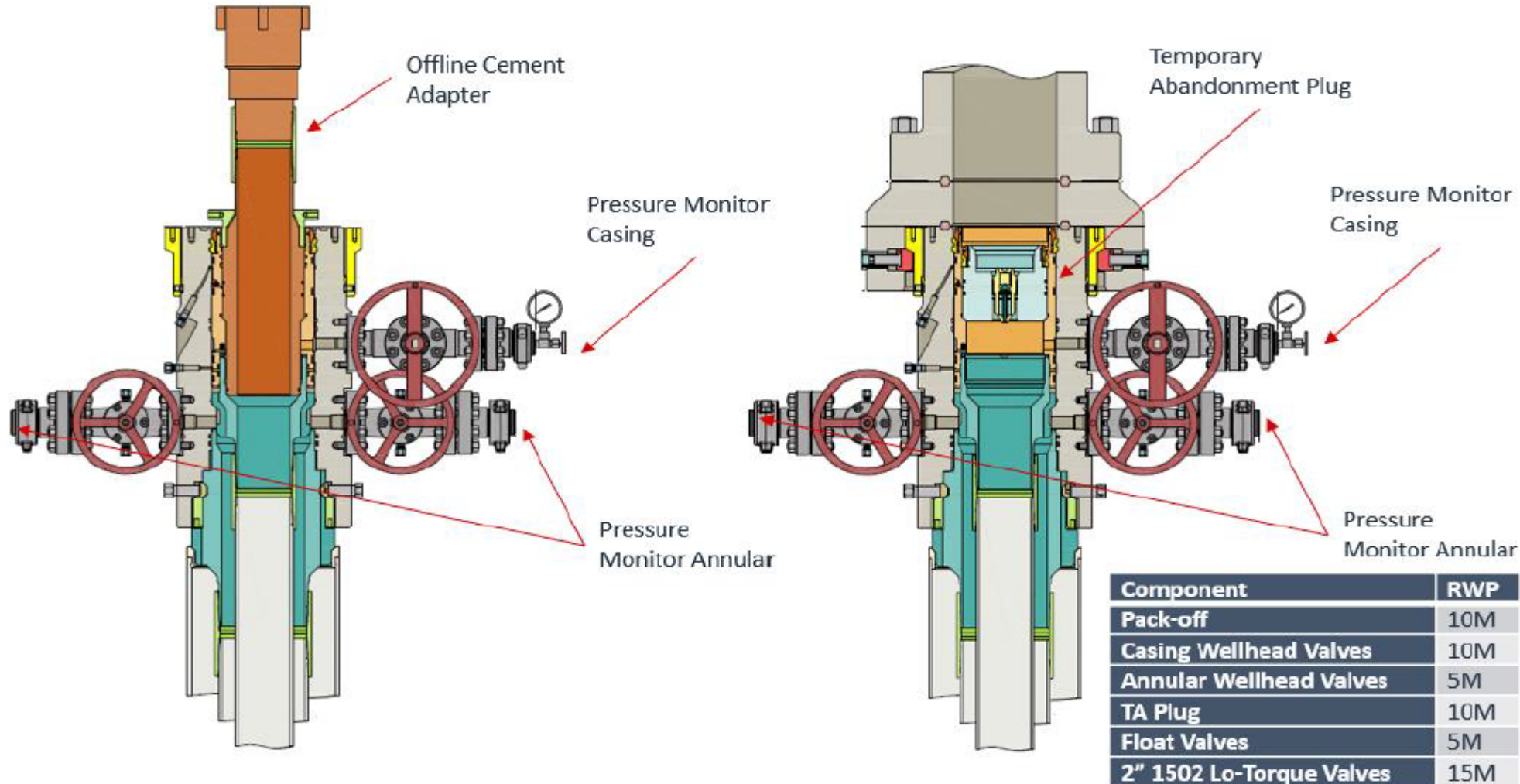

Offline Surface + Intermediate Cement

Figure 3: Back Yard Rig Up

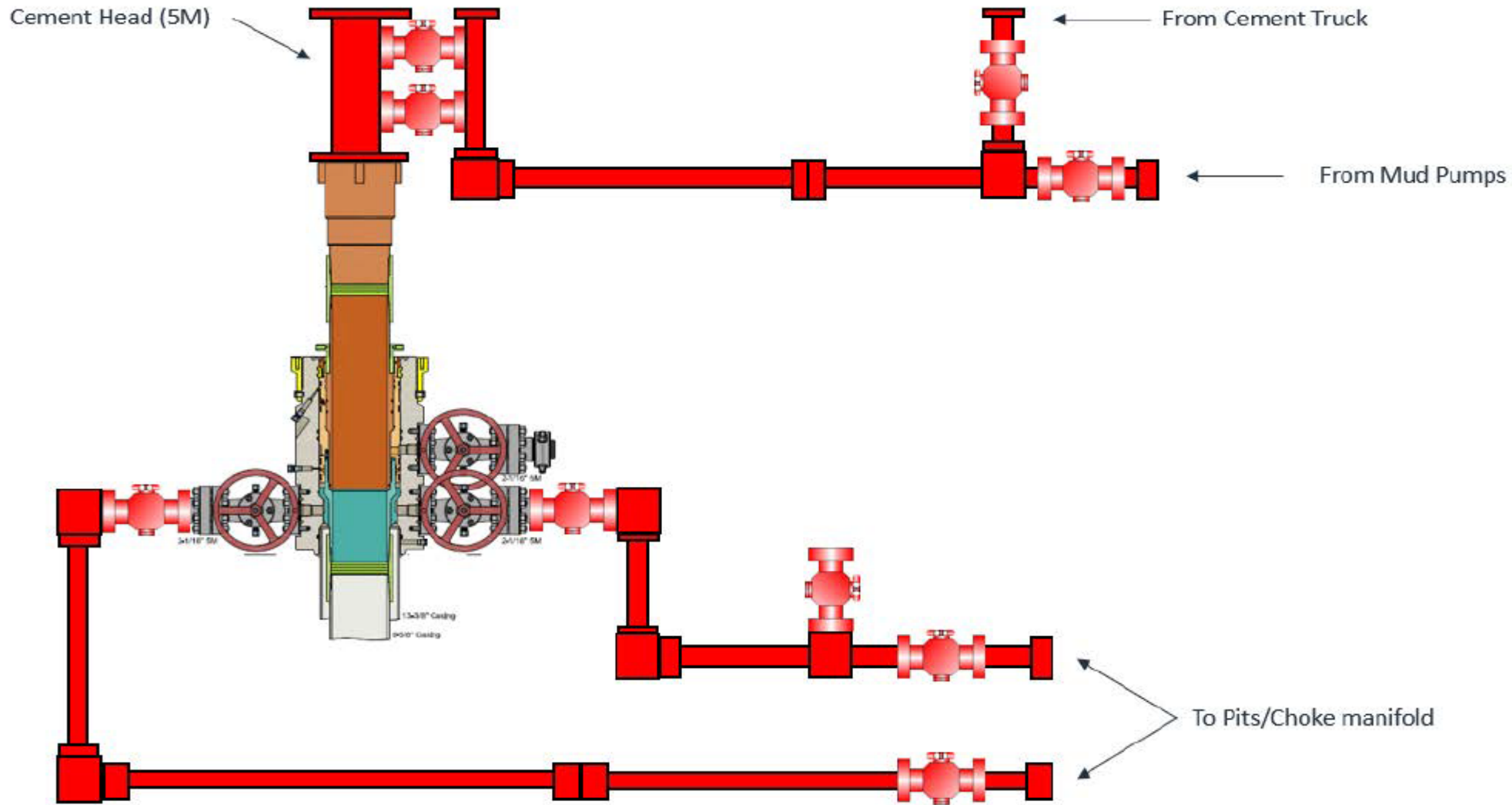

Offline Surface + Intermediate Cement

Figure 4: Rig Placement Diagram

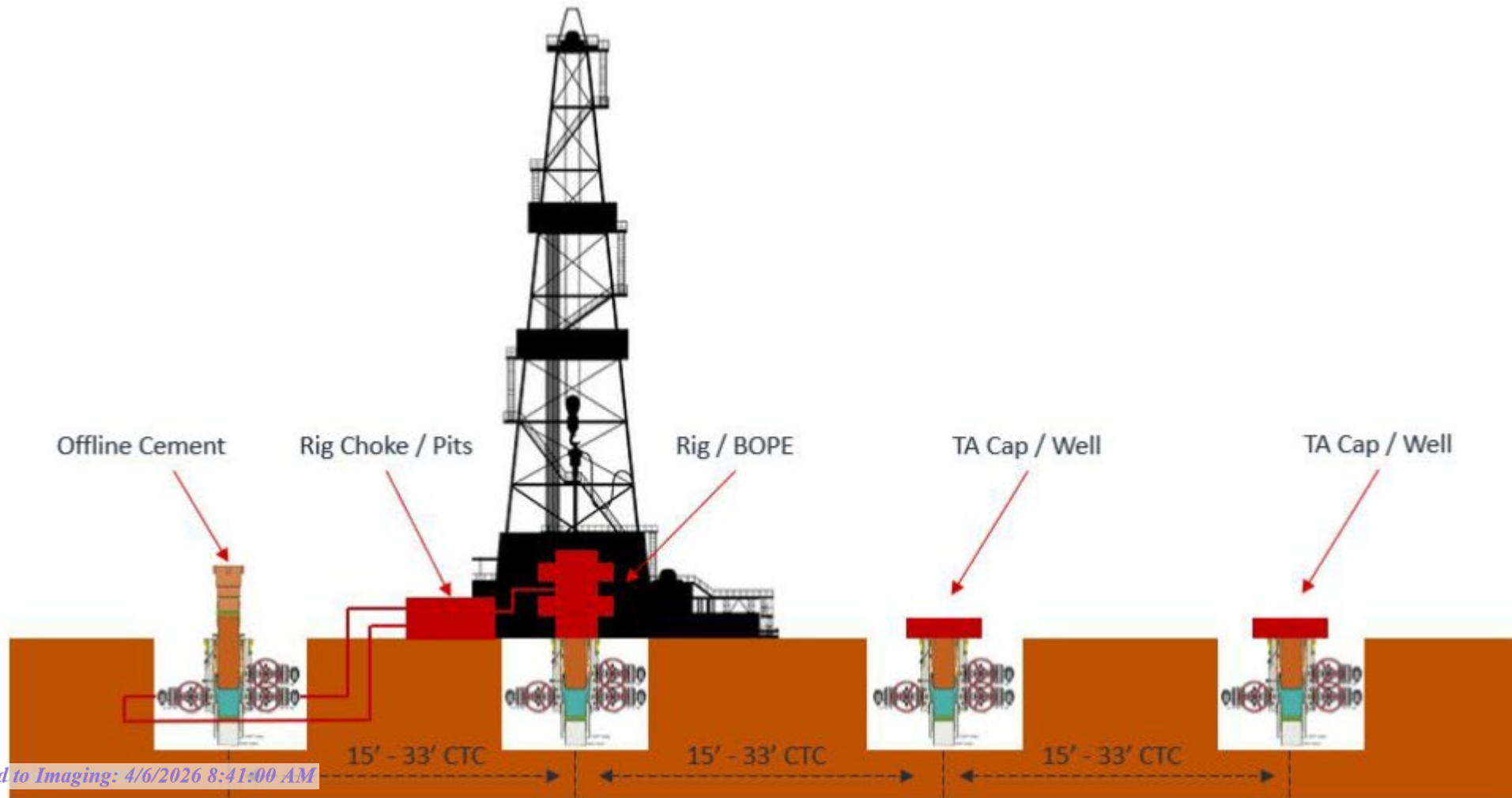



Intermediate Bradenhead Cement Variance

Intermediate Bradenhead Cement

Deep Target Intermediate Bradenhead:

EOG requests variance from minimum standards to pump a two stage cement job on the intermediate casing string **when set below the Delaware Mountain Group** with the first stage being pumped conventionally with the calculated top of cement at the Brushy Canyon and the second stage bradenhead squeezed to be performed at a minimum of **50% of OH excess (typically increased to ~1,000 sacks)** with planned cement from the Brushy Canyon to surface. If necessary, a top out consisting of Class C/H cement + additives (2.30 yld, 12.91 ppg) will be executed as a contingency. Top of cement will be verified by Echo-meter.

EOG will include the Echo-meter verified fluid top and the volume of displacement fluid above the cement slurry in the annulus in all post-drill sundries on wells utilizing this cement program.

EOG will report to the BLM the volume of fluid (limited to 5 bbls) used to flush intermediate casing valves following backside cementing procedures.



Wolfcamp Intermediate Casing Setpoint

Intermediate Bradenhead Cement

EOG Resources Inc. (EOG) requests a variance to set the intermediate casing shoe in the Bone Spring formation OR the Wolfcamp formation, depending on depletion in the area and well conditions. EOG will monitor the well and ensure the well is static before casing operations begin.



Offline Production Cement Variance

EOG Offline Production Checklist

Offline Checklist

All items below must be met. If not, the production cement will be done online.

1. Offline production cement jobs **are applicable for the Base of the Wolfcamp or shallower.**
2. Nothing out of the ordinary observed during drilling, tripping, or casing running operations in the Production Hole Section.
3. Casing must be landed with Hanger.
4. EOG Company Man and Superintendent with Well Control certification must be present to monitor returns.
5. EOG Cement Advisor must be present to oversee the Cement Job.
6. Rig Manager is responsible for walking the rig to the next well.
7. The BOP will NOT be nipped down if:
 - a) ANY barrier fails to test.
 - b) ANY offset frac operations are observed within 1 mile and within the same producing horizon.
8. After all barriers test and the BLM has been notified, the BOP may be nipped down to proceed with offline operations.
9. EOG will not Drill out of the next well until Cement Operations have concluded on the offline well.

Offline Procedure

1. Run casing as per normal operations. Review EOG Offline Requirements Checklist, if the well is a candidate for Offline Cement on the Production continue following this procedure. Conduct negative pressure test while running casing and confirm integrity of the float equipment back pressure valves.
 - a. Float equipment is equipped with two back pressure valves rated to 15,000 psi.
2. Land production casing on mandrel hanger.
 - a. **If casing is unable to be landed with a mandrel hanger, then the casing will be cemented online.**
 - b. If utilizing a fluted/ported mandrel hanger, ensure well is static on the annulus and inside the casing by filling the pipe with kill weight fluid, remove landing joint, and set annular packoff rated to 10,000 psi. Pressure test same to 10,000 psi.
 - c. If utilizing a solid mandrel hanger, ensure well is static on the annulus and inside the casing by filling the pipe with kill weight fluid. Pressure test seals to 10,000 psi. Remove landing joint.
3. Install back pressure valve in the casing for a 3rd casing barrier.
 - a. Back pressure valve rated to a minimum of 10,000 psi.
4. With the well Secured and BLM notified; Nipple down BOP and secure on hydraulic carrier or cradle and Skid/Walk rig to next well on pad.
 - a. **Note, if any of the barriers fail to test, the BOP stack will not be nipped down until after the cement job has concluded.**
 - b. **Note, EOG Company Man and Cement Advisor will oversee Cementing Operations while Rig Manager walks the rig and nipples up the BOP.**
 - c. **Note, EOG will not drill out of the subsequent well until after plug bump.**
5. Install 10M Gate Valve, with Wellhead Adapter.
 - a. This creates an additional barrier on the annulus and inside the casing.
 - b. Gate valve rated to a minimum of 10,000 psi.
6. Test connection between Wellhead Adapter seals against hanger neck and ring gasket to 10,000 psi.
7. Remove backpressure valve from the casing.
8. Rig up cement head and cementing lines.
9. After rig up of cement head and cement lines, and confirmation of the annular barriers and casing barriers, notify the BLM with intent to proceed offline cementing.
10. Perform cement job.
11. *Note* – Procedure continued on the next page.

Offline Procedure

12. If an influx is noted during the Cement Job:
 - a. It is the Company Man and Superintendent's responsibility to maintain well control.
 - b. The aux manifold will be redirected to the rig's chokes.
 - c. Backpressure will be held on the well with the chokes to ensure well control is maintained through the remainder of the cement job while circulating out the influx.
 - d. If annular surface pressure approaches 90% tested pressure of the manifold or if circulating the influx out with the cementing pumps is not feasible, the well can be secured by closing the casing valves (10M).
 - e. Once cement is in place, we will close the casing valves and confirm the well is static and floats are holding.
 - f. If the floats fail, the gate valve (10M) or cement head (10M) can be closed to secure the well.
13. Confirm well is static and floats are holding after cement job.
14. Remove cement head.
15. Install back pressure valve.
16. Remove 10M Gate Valve and Wellhead Adapter.
17. Install night cap with pressure gauge for monitoring.
18. Test night cap to 5,000 psi.

Offline Barrier Overview

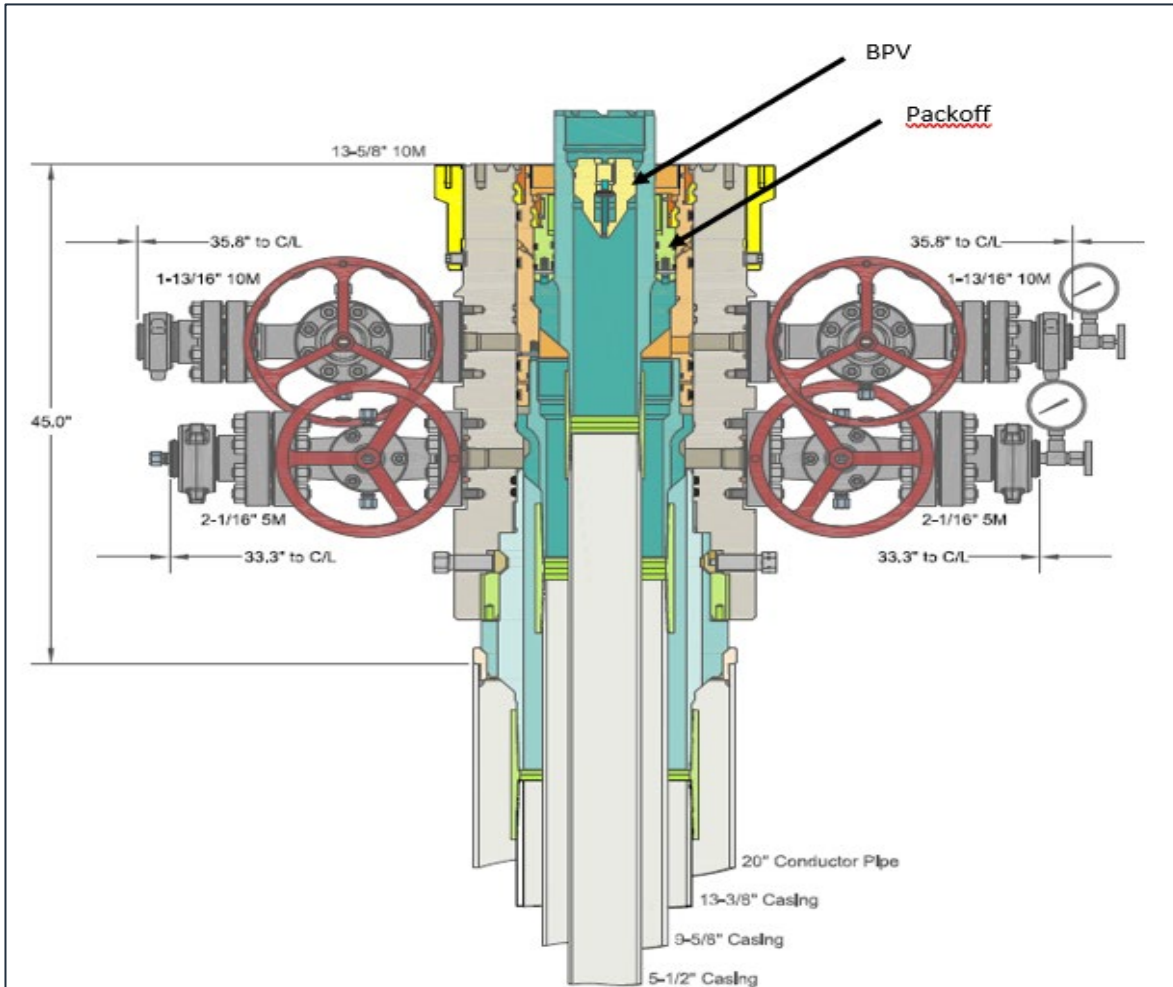

ALL DIMENSIONS APPROXIMATE

CACTUS WELLHEAD LLC **EOG RESOURCES PERMIAN**

13-3/8" x 9-5/8" x 5-1/2" MBU-3T-CFL-DBLO-SF Wellhead System
 13-3/8", 9-5/8" & 5-1/2" Pin Bottom Mandrel Casing Hangers

Released to Imaging: 4/6/2026 8:41:00 AM
 DRAWN: DLE 28AUG19
 APPRV: [Signature]
 DRAWING NO. SDT-2297-2

Barriers in Place during removal of BOP

Operation	Casing	Annulus
Nipling Down BOP	1. BPV 2. Hydrostatic Barrier 3. Float Valves	1. Hydrostatic Barrier 2. Mechanical 10M Packoff

Barriers in Place during Offline Cementing of Production Casing

Operation	Casing	Annulus
Pull BPV	1. Hydrostatic Barrier 2. Float Valves 3. 10M Gate Valve	1. Hydrostatic Barrier 2. Mechanical Packoff 3. 10M Wellhead Adapter
Install Cement Head	1. Hydrostatic Barrier 2. Float Valves 3. 10M Gate Valve	1. Hydrostatic Barrier 2. Mechanical 10M Packoff 3. 10M Wellhead Adapter
Cement Job	1. Hydrostatic Barrier 2. Float Valves 3. 10M Gate Valve 4. Cement Head	1. Hydrostatic Barrier 2. Mechanical 10M Packoff 3. 10M Wellhead Adapter
Remove Cement Head	1. Float Valves 2. 10M Gate Valve	1. Hydrostatic Barrier 2. Mechanical 10M Packoff 3. 10M Wellhead Adapter
Install BPV	1. Float Valves 2. 10M Gate Valve	1. Hydrostatic Barrier 2. Mechanical 10M Packoff 3. 10M Wellhead Adapter
Remove 10M Gate Valve	1. Float Valves 2. BPV	1. Hydrostatic Barrier 2. Mechanical 10M Packoff
Nipple Up TA Cap	1. Float Valves 2. BPV	1. Hydrostatic Barrier 2. Mechanical 10M Packoff

Offline Barrier Overview

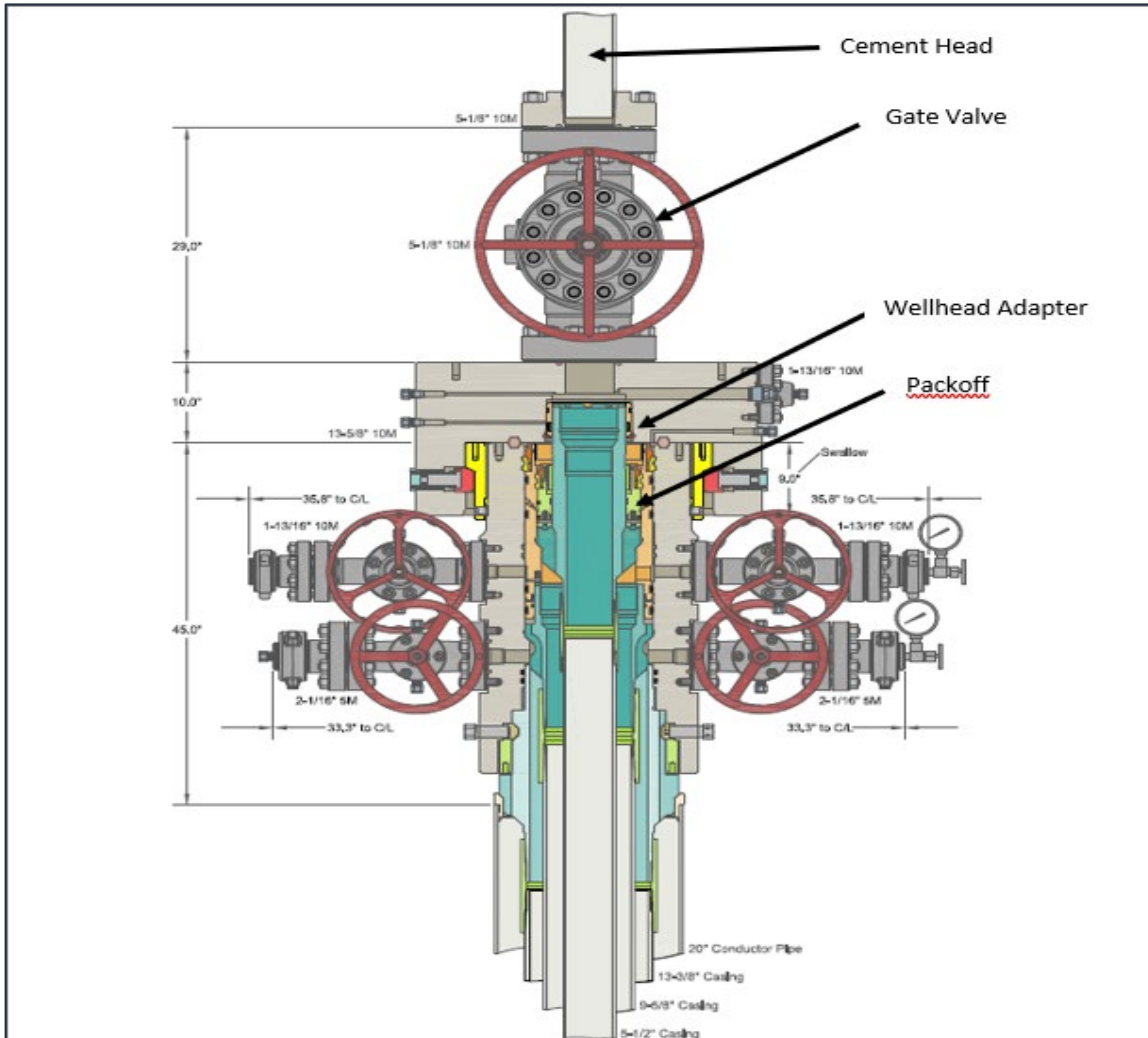

INFORMATION CONTAINED HEREIN IS THE PROPERTY OF CACTUS WELLHEAD, LLC. REPRODUCTION, DISCLOSURE, OR USE THEREOF IS PERMISSIBLE ONLY AS PROVIDED BY CONTRACT OR AS EXPRESSLY AUTHORIZED BY CACTUS WELLHEAD, LLC.

ALL DIMENSIONS APPROXIMATE

CACTUS WELLHEAD LLC		EOG RESOURCES PERMIAN	
13-3/8" x 9-5/8" x 5-1/2" MBU-3T-CFL-DBLO-SF Wellhead System		DRAWN	DLE 28AUG19
Offline Cement Package		APPRV	
And 13-3/8", 9-5/8" & 5-1/2" Pin Bottom Mandrel Casing Hangers		DRAWING NO.	SDT-2297-3

Barriers in Place during removal of BOP

Operation	Casing	Annulus
Nipling Down BOP	1. BPV 2. Hydrostatic Barrier 3. Float Valves	1. Hydrostatic Barrier 2. Mechanical 10M Packoff

Barriers in Place during Offline Cementing of Production Casing

Operation	Casing	Annulus
Pull BPV	1. Hydrostatic Barrier 2. Float Valves 3. 10M Gate Valve	1. Hydrostatic Barrier 2. Mechanical Packoff 3. 10M Wellhead Adapter
Install Cement Head	1. Hydrostatic Barrier 2. Float Valves 3. 10M Gate Valve	1. Hydrostatic Barrier 2. Mechanical 10M Packoff 3. 10M Wellhead Adapter
Cement Job	1. Hydrostatic Barrier 2. Float Valves 3. 10M Gate Valve 4. Cement Head	1. Hydrostatic Barrier 2. Mechanical 10M Packoff 3. 10M Wellhead Adapter
Remove Cement Head	1. Float Valves 2. 10M Gate Valve	1. Hydrostatic Barrier 2. Mechanical 10M Packoff 3. 10M Wellhead Adapter
Install BPV	1. Float Valves 2. 10M Gate Valve	1. Hydrostatic Barrier 2. Mechanical 10M Packoff 3. 10M Wellhead Adapter
Remove 10M Gate Valve	1. Float Valves 2. BPV	1. Hydrostatic Barrier 2. Mechanical 10M Packoff
Nipple Up TA Cap	1. Float Valves 2. BPV	1. Hydrostatic Barrier 2. Mechanical 10M Packoff

More Control: Meeting/Exceeding Barrier Requirements

Casing Barriers – Online vs Offline		
Operation	Online	Offline
Install Cement Head	1. Hydrostatic Barrier 2. Float Valves	1. Hydrostatic Barrier 2. Float Valves 3. 10M Gate Valve
Cement Job	1. Hydrostatic Barrier 2. Float Valves 3. Cement Head	1. Hydrostatic Barrier 2. Float Valves 3. 10M Gate Valve 4. Cement Head
Remove Cement Head	1. Float Valves	1. Float Valves 2. 10M Gate Valve
Install BPV & Nipple Down BOP / Offline Adapter	1. Float Valves	1. Float Valves 2. BPV
Nipple Up TA Cap	1. Float Valves	1. Float Valves 2. BPV

Annulus Barriers – Online vs Offline		
Operation	Online	Offline
Install Cement Head	1. Hydrostatic Barrier 2. Annular 3. VBR	1. Hydrostatic Barrier 2. Mechanical Pack-off 3. 10M Wellhead Adapter
Cement Job	1. Hydrostatic Barrier 2. Annular 3. VBR	1. Hydrostatic Barrier 2. Mechanical Pack-off 3. 10M Wellhead Adapter
Remove Cement Head	1. Hydrostatic Barrier 2. Annular 3. VBR	1. Hydrostatic Barrier 2. Mechanical Pack-off 3. 10M Wellhead Adapter
Install BPV & Nipple Down BOP / Offline Adapter	1. Hydrostatic barrier 2. Mechanical Pack-off	1. Hydrostatic Barrier 2. Mechanical Pack-off
Nipple Up TA Cap	1. Hydrostatic barrier 2. Mechanical Pack-off	1. Hydrostatic Barrier 2. Mechanical Pack-off

Return Rig Up Diagram

Online

Offline

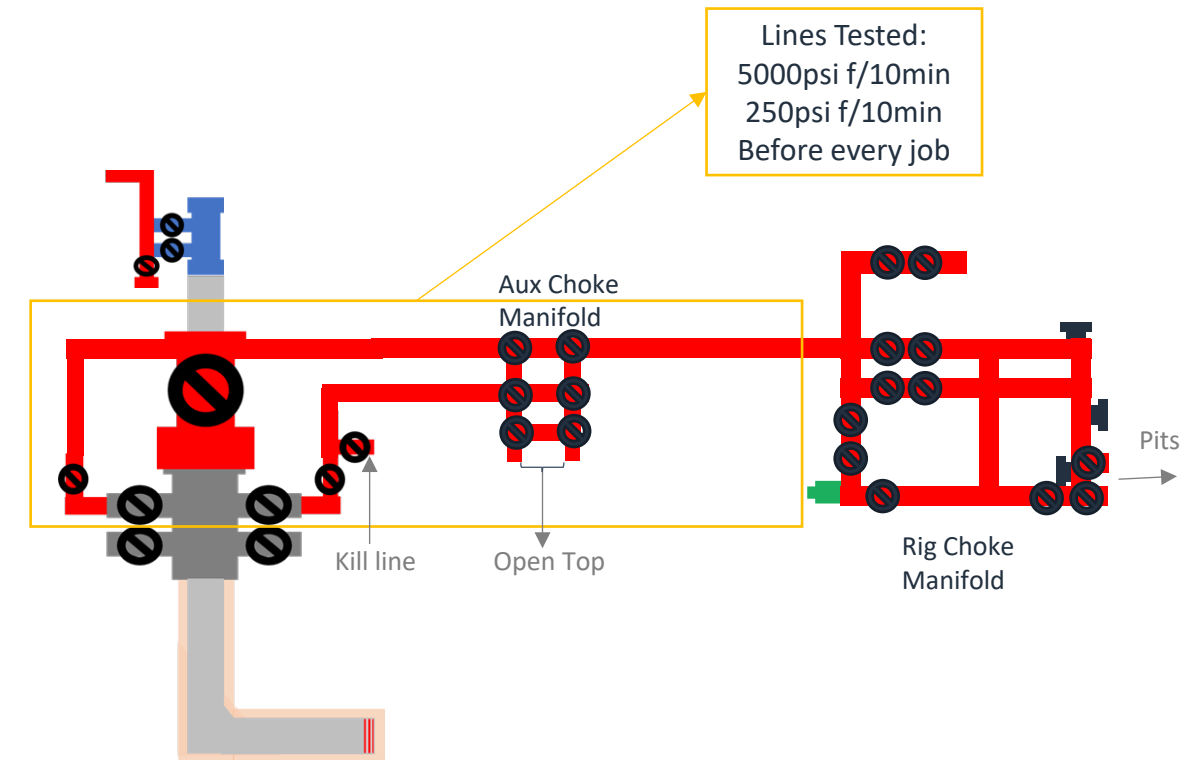
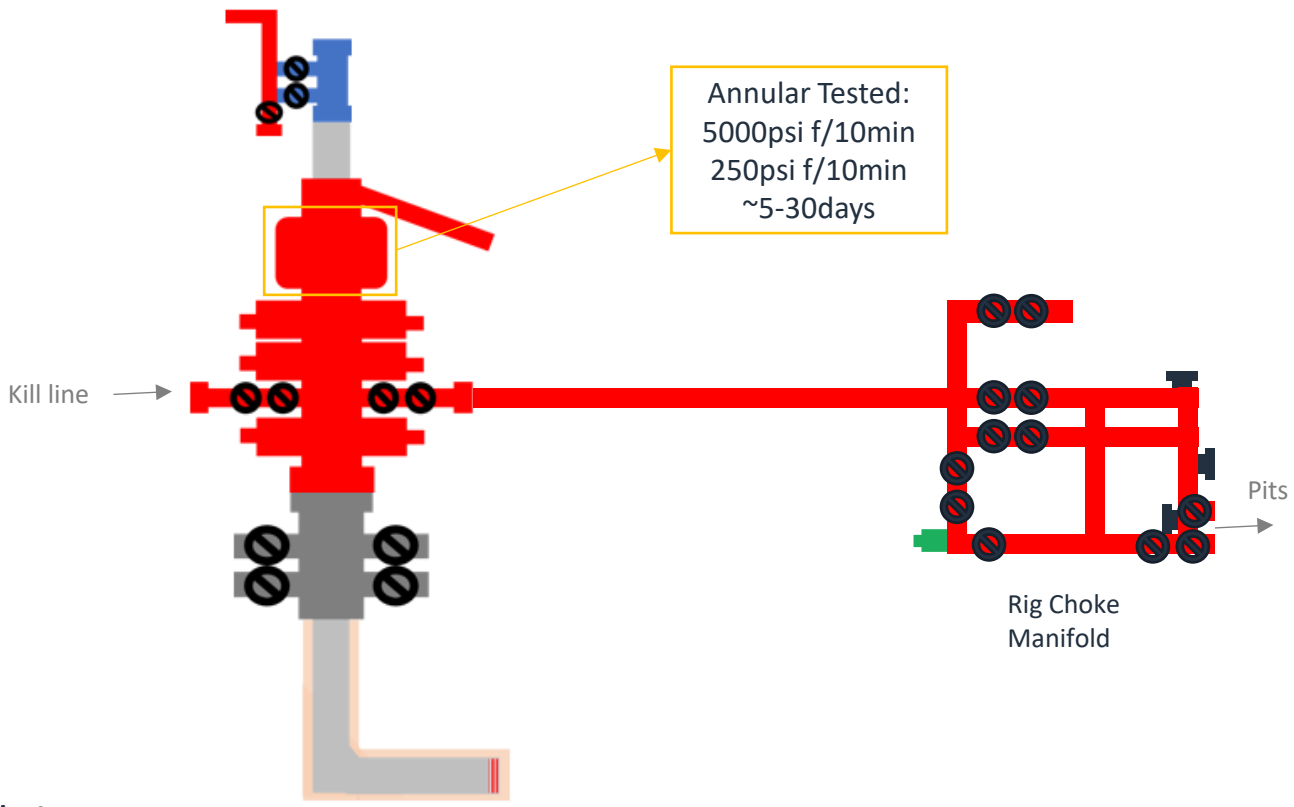

Note:

- 1) Have the Rig's same Well Control Capabilities as Online
- 2) Have more flexibility with Gate Valve than with a Landing Joint through BOP
- 3) Never had to circulate out a kick during Offline



Production Bradenhead Cement Variance

Production Bradenhead Cement

Shallow Target Production Offline Bradenhead:

EOG Resources Inc. (EOG) respectfully requests a variance from the minimum standards to allow for offline bradenhead cementing of the production string after primary cementing operations have been completed. The primary cement job will be pumped conventionally (online) to top of the Brushy Canyon and will cover the target production intervals, and after production pack-off is set and tested, bradenhead will be pumped through casing valves between the production and intermediate casings (offline). For the bradenhead stage of production cementing, the barriers remain the same for offline cementing compared to performing it online.

The bradenhead will be the primary option for production cementing. EOG also requests to have the conventional option in place to accommodate for logistical or wellbore conditions. The tie back requirements will be met if the cement is pumped conventionally, and cement volumes will be adjusted accordingly. TOC will be verified by CBL.



Salt Section Annular Clearance

Current Design (Salt Strings)

0.422" Annular clearance requirement

- Casing collars shall have a minimum clearance of 0.422 inches on all sides in the hole/casing annulus, with recognition that variances can be granted for justified exceptions.

- 12.25" Hole x 9.625" 40# J55/HCK55 LTC Casing
 - 1.3125" Clearance to casing OD
 - 0.8125" Clearance to coupling OD
- 9.875" Hole x 8.75" 38.5# P110 Sprint-SF Casing
 - 0.5625" Clearance to casing OD
 - 0.433" Clearance to coupling OD

Annular Clearance Variance Request

EOG request permission to allow deviation from the 0.422" annulus clearance requirement for the intermediate (salt) section from Onshore Order #2 under the following conditions:

- The variance is not applicable within the Potash Boundaries or Capitan Reef areas.
- Operator takes responsibility to get casing to set point in the event that the clearance causes stuck pipe issues

Volumetric Hole Size Calculation

Hole Size Calculations Off Cement Volumes

- Known volume of cement pumped
- Known volume of cement returned to surface
- Must not have had any losses
- Must have bumped plug

Average Hole Size

- 12.25" Hole
 - 12.88" Hole
 - 5.13% diameter increase
 - 10.52% area increase
 - 0.63" Average enlargement
 - 0.58" Median enlargement
 - 179 Well Count
- 9.875" Hole
 - 10.30" Hole
 - 4.24% diameter increase
 - 9.64% area increase
 - 0.42" Average enlargement
 - 0.46" Median enlargement
 - 11 Well Count

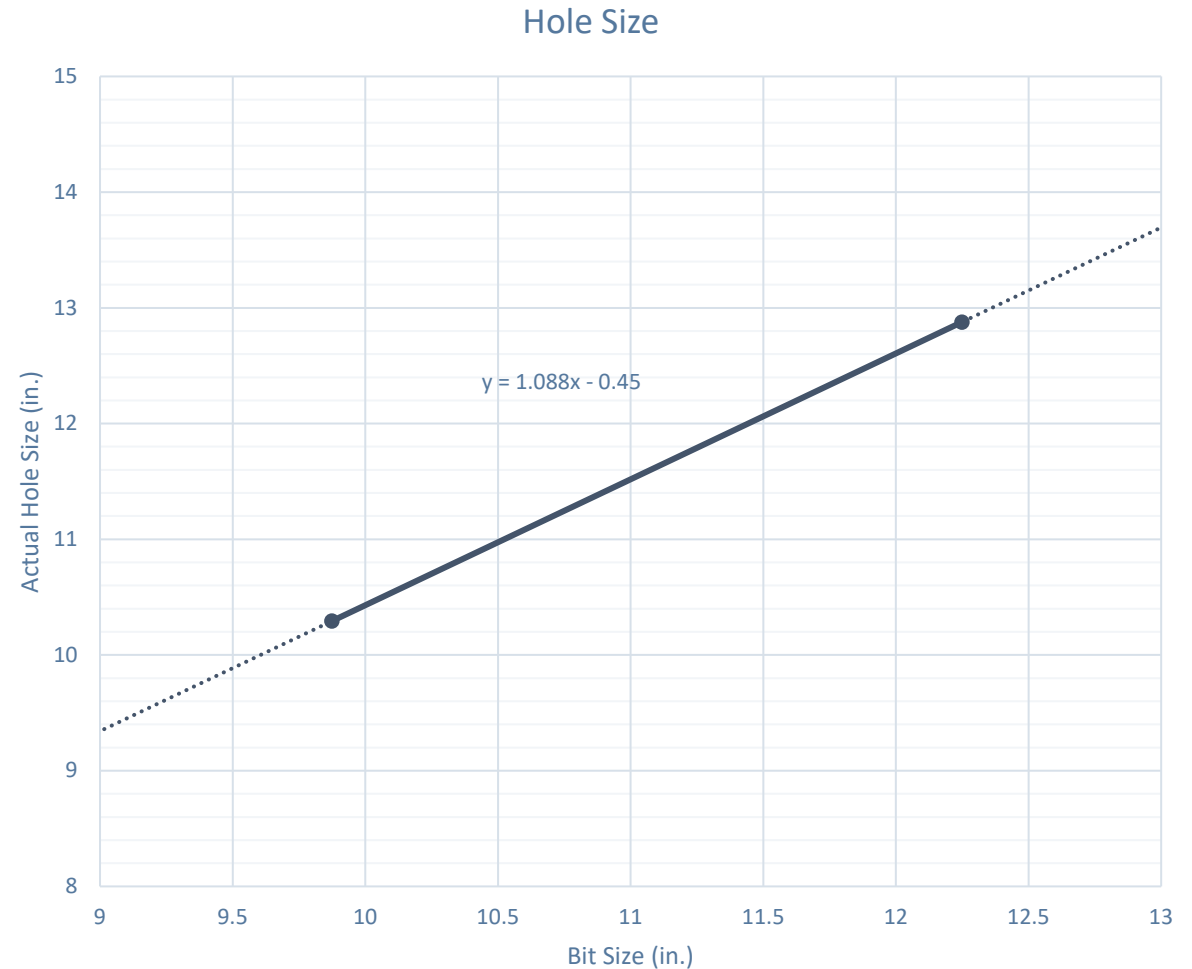

Caliper Hole Size (12.25")

Average Hole Size

- 12.25" Bit
 - 12.76" Hole
 - 4.14% diameter increase
 - 8.44% area increase
 - 0.51" Average enlargement
 - 0.52" Median enlargement
 - Brine

Modelo 10 Fed Com #501H

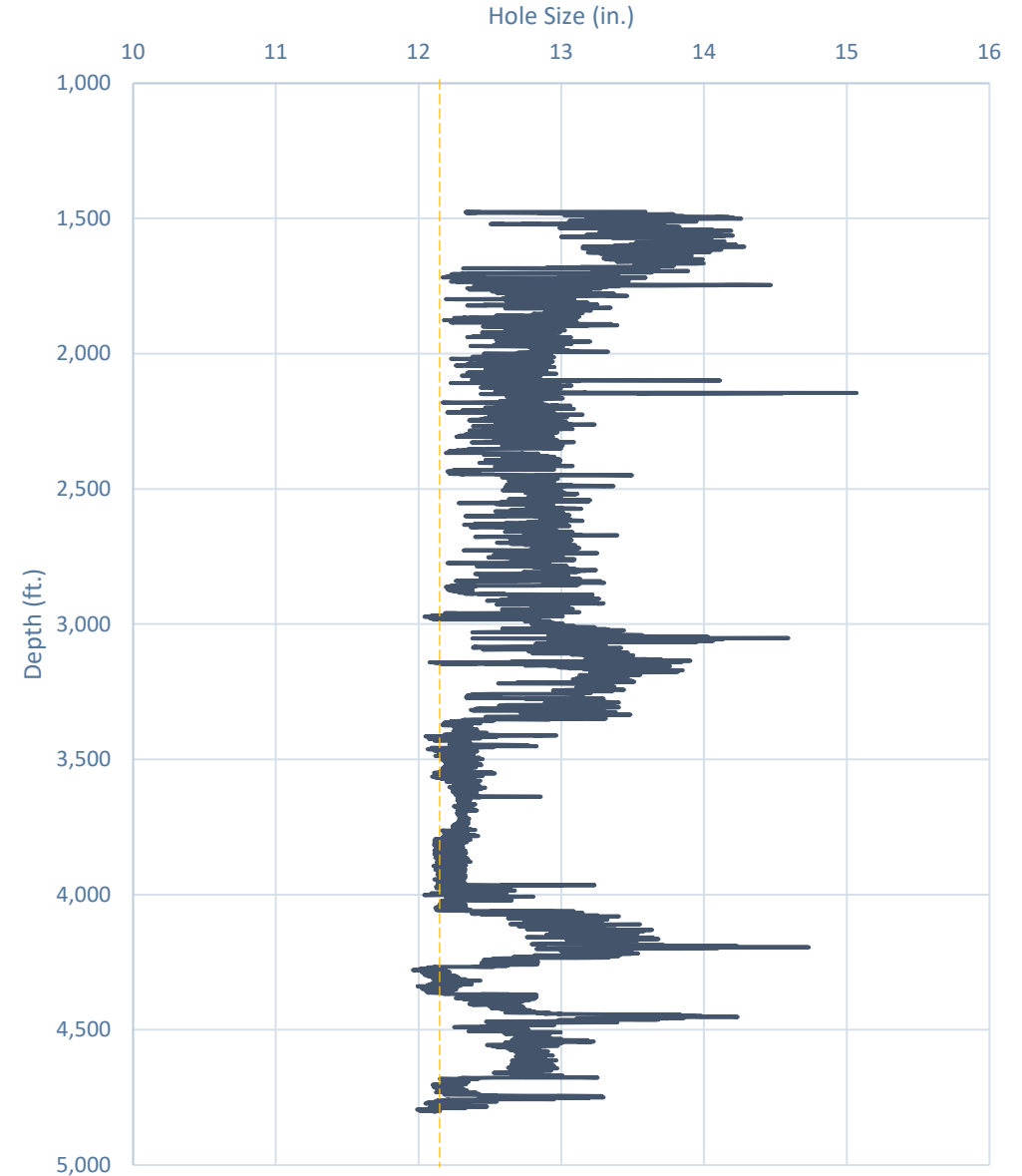

Caliper Hole Size (9.875")

Average Hole Size

- 9.875" Hole
 - 11.21" Hole
 - 13.54% diameter increase
 - 28.92% area increase
 - 1.33" Average enlargement
 - 1.30" Median enlargement
 - EnerLite

Whirling Wind 11 Fed Com #744H

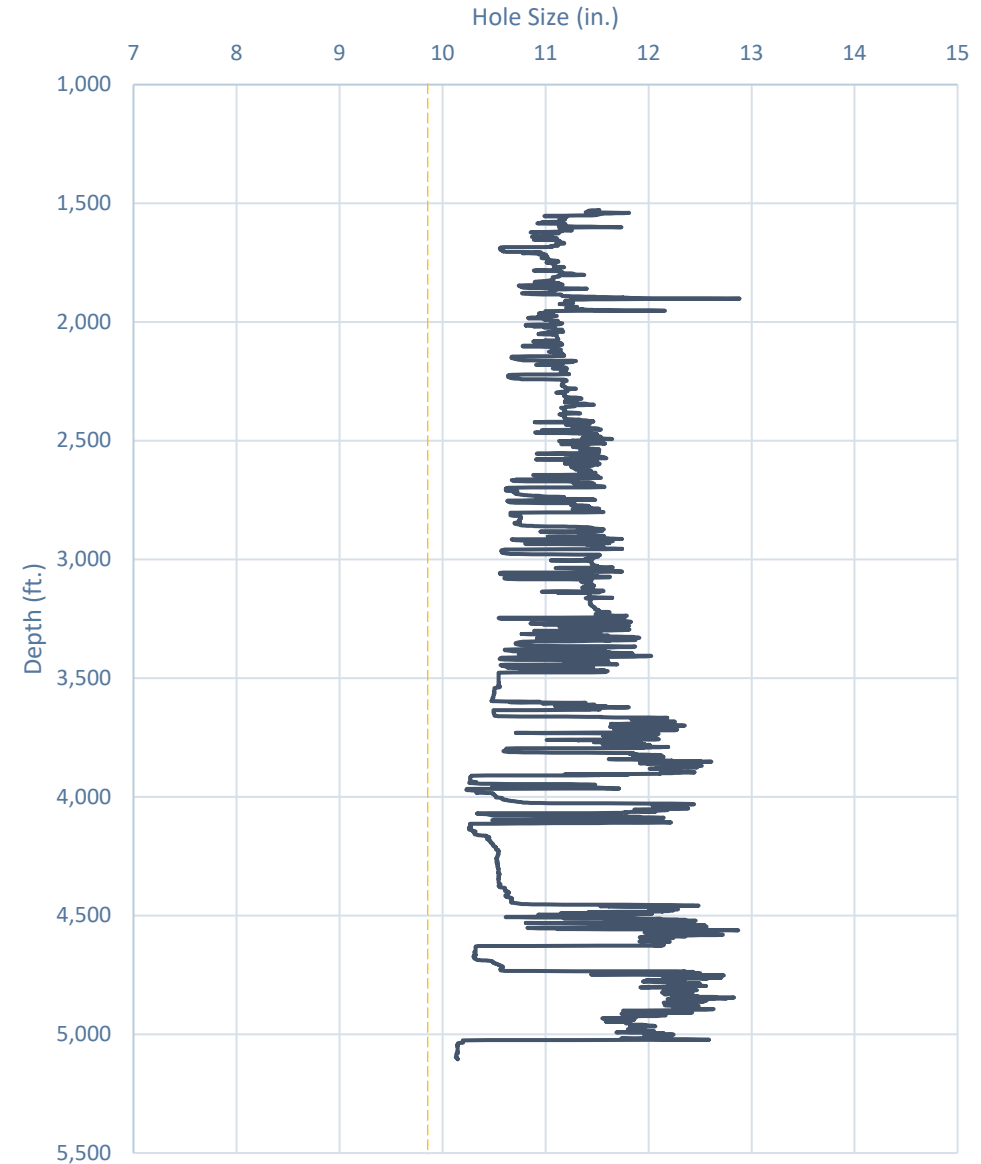

Design A

Proposed 11" Hole with 9.625" 40# J55/HCK55 LTC Casing

- 11" Bit + 0.52" Average hole enlargement = 11.52" Hole Size
 - 0.9475" Clearance to casing OD

$$= \frac{11.52 - 9.625}{2}$$
 - 0.4475" Clearance to coupling OD

$$= \frac{11.52 - 10.625}{2}$$
- Previous Shoe – 13.375" 54.5# J55 STC
 - 0.995" Clearance to coupling OD (~1,200' overlap)

$$= \frac{12.615 - 10.625}{2}$$

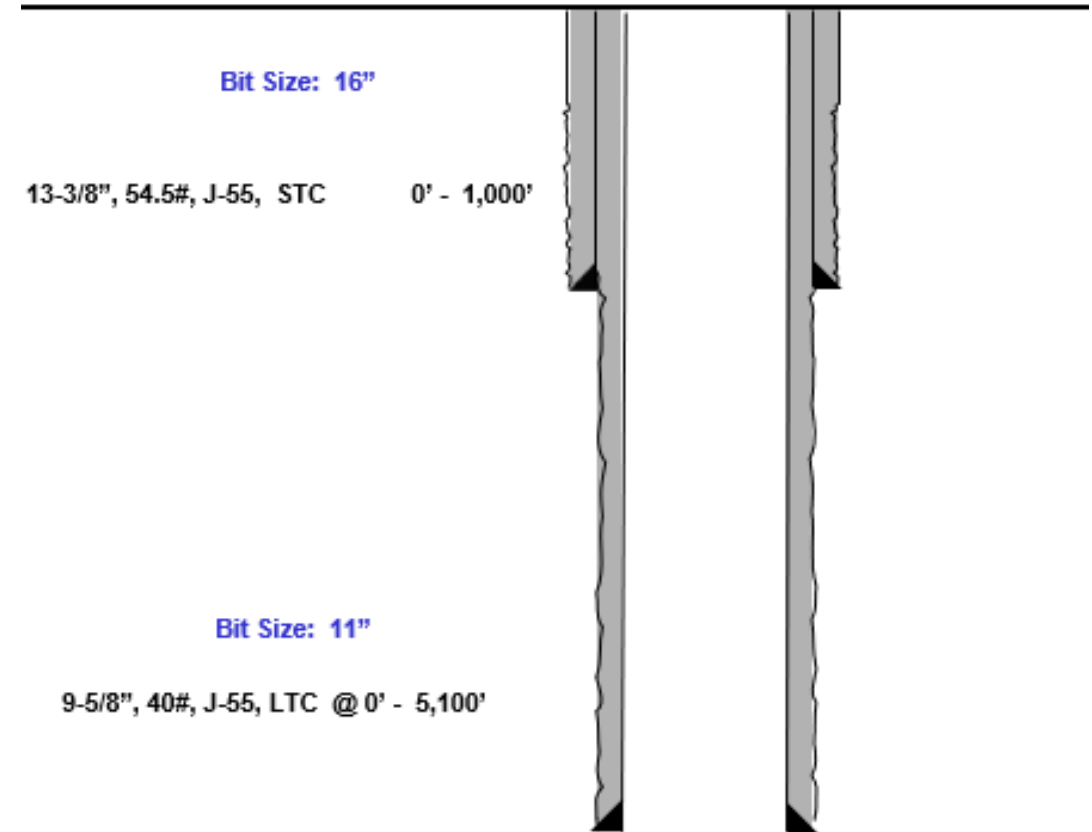

Design B

Proposed 9.875" Hole with 8.625" 32# J55/P110 BTC-SC Casing

- 9.875" Bit + 0.42" Average hole enlargement = 10.295" Hole Size
 - 0.835" Clearance to casing OD

$$= \frac{10.295 - 8.625}{2}$$
 - 0.585" Clearance to coupling OD

$$= \frac{10.295 - 9.125}{2}$$
- Previous Shoe – 10.75" 40.5# J55 STC
 - 0.4625" Clearance to coupling OD (~1,200' overlap)

$$= \frac{10.05 - 9.125}{2}$$

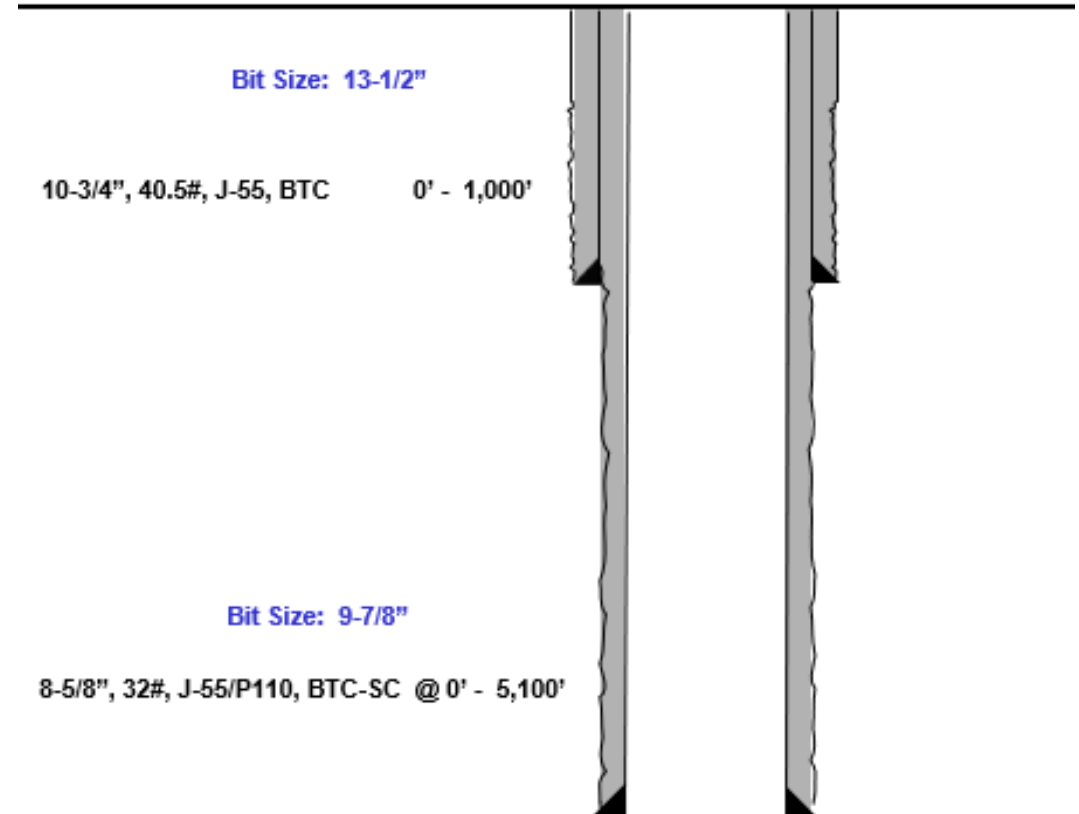



Index



Casing Spec Sheets

Pipe Body and API Connections Performance Data

10.750 40.50/0.350 J55

PDF

New Search »

« Back to Previous List

USC Metric

6/8/2015 10:14:05 AM

Mechanical Properties	Pipe	BTC	LTC	STC	
Minimum Yield Strength	55,000	--	--	--	psi
Maximum Yield Strength	80,000	--	--	--	psi
Minimum Tensile Strength	75,000	--	--	--	psi
Dimensions	Pipe	BTC	LTC	STC	
Outside Diameter	10.750	11.750	--	11.750	in.
Wall Thickness	0.350	--	--	--	in.
Inside Diameter	10.050	10.050	--	10.050	in.
Standard Drift	9.894	9.894	--	9.894	in.
Alternate Drift	--	--	--	--	in.
Nominal Linear Weight, T&C	40.50	--	--	--	lbs/ft
Plain End Weight	38.91	--	--	--	lbs/ft
Performance	Pipe	BTC	LTC	STC	
Minimum Collapse Pressure	1,580	1,580	--	1,580	psi
Minimum Internal Yield Pressure	3,130	3,130	--	3,130	psi
Minimum Pipe Body Yield Strength	629.00	--	--	--	1000 lbs
Joint Strength	--	700	--	420	1000 lbs
Reference Length	--	11,522	--	6,915	ft
Make-Up Data	Pipe	BTC	LTC	STC	
Make-Up Loss	--	4.81	--	3.50	in.
Minimum Make-Up Torque	--	--	--	3,150	ft-lbs
Maximum Make-Up Torque	--	--	--	5,250	ft-lbs



API 5CT, 10th Ed. Connection Data Sheet

O.D. (in)	WEIGHT (lb/ft)	WALL (in)	GRADE	*API DRIFT (in)	RBW %
8.625	Nominal: 32.00 Plain End: 31.13	0.352	J55	7.796	87.5

Material Properties (PE)

Pipe	
Minimum Yield Strength:	55 ksi
Maximum Yield Strength:	80 ksi
Minimum Tensile Strength:	75 ksi
Coupling	
Minimum Yield Strength:	55 ksi
Maximum Yield Strength:	80 ksi
Minimum Tensile Strength:	75 ksi

Pipe Body Data (PE)

Geometry	
Nominal ID:	7.92 inch
Nominal Area:	9.149 in ²
*Special/Alt. Drift:	7.875 inch
Performance	
Pipe Body Yield Strength:	503 kips
Collapse Resistance:	2,530 psi
Internal Yield Pressure: (API Historical)	3,930 psi

API Connection Data

Coupling OD: 9.625"

STC Performance	
STC Internal Pressure:	3,930 psi
STC Joint Strength:	372 kips
LTC Performance	
LTC Internal Pressure:	3,930 psi
LTC Joint Strength:	417 kips
SC-BTC Performance - Cplg OD = 9.125"	
BTC Internal Pressure:	3,930 psi
BTC Joint Strength:	503 kips

API Connection Torque

STC Torque (ft-lbs)		
Min:	2,793	Opti: 3,724 Max: 4,655
LTC Torque (ft-lbs)		
Min:	3,130	Opti: 4,174 Max: 5,217
BTC Torque (ft-lbs)		
follow API guidelines regarding positional make up		

*Alt. Drift will be used unless API Drift is specified on order.

**If above API connections do not suit your needs, VAM® premium connections are available up to 100% of pipe body ratings.

ALL INFORMATION IS PROVIDED BY VALLOUREC OR ITS AFFILIATES AT USER'S SOLE RISK, WITHOUT LIABILITY FOR LOSS, DAMAGE OR INJURY RESULTING FROM THE USE THEREOF, AND ON AN "AS IS" BASIS WITHOUT WARRANTY OR REPRESENTATION OF ANY KIND, WHETHER EXPRESS OR IMPLIED, INCLUDING WITHOUT LIMITATION ANY WARRANTY OF MERCHANTABILITY, FITNESS FOR PURPOSE, ACCURACY OR COMPLETENESS. THE INFORMATION CONTAINED IN THIS DOCUMENT IS PROVIDED FOR INFORMATIONAL PURPOSES ONLY AND IS BASED ON ESTIMATES THAT HAVE NOT BEEN VERIFIED OR TESTED. IN NO EVENT SHALL VALLOUREC OR ITS AFFILIATES BE RESPONSIBLE FOR ANY INDIRECT, SPECIAL, INCIDENTAL, PUNITIVE, EXEMPLARY OR CONSEQUENTIAL LOSS OR DAMAGE (INCLUDING WITHOUT LIMITATION, LOSS OF USE, LOSS OF BARGAIN, LOSS OF REVENUE, PROFIT OR ANTICIPATED PROFIT) HOWEVER CAUSED OR ARISING, AND WHETHER SUCH LOSSES OR DAMAGES WERE FORESEEABLE OR VALLOUREC OR ITS AFFILIATES WERE ADVISED OF THE POSSIBILITY OF SUCH DAMAGES.

Rev 3, 7/30/2021

10/21/2022 15:24





Break-test BOP & Offline Cementing:

EOG Resources Inc. (EOG) respectfully requests a variance from the minimum standards for well control equipment testing of ECFR Title 43 Part 3172.6(b)(9)(iv) to allow a testing schedule of the blow out preventer (BOP) and blow out prevention equipment (BOPE) along with Batch Drilling & Offline cement operations to include the following:

- Full BOPE test at first installation on the pad.
- Full BOPE test every 30 days.
- This test will be conducted for 5M rated hole intervals only.
- Each rig requesting the break-test variance is capable of picking up the BOP without damaging components using winches, following API Standard 53, Well Control Equipment Systems for Drilling Wells (Fifth edition, December 2018, Annex C. Table C.4) which recognizes break testing as an acceptable practice.
- Function tests will be performed on the following BOP elements:
 - Annular → during each full BOPE test
 - Upper Pipe Rams → On trip ins where FIT required
 - Blind Rams → Every trip
 - Lower Pipe Rams → during each full BOPE test
- Break testing BOP and BOPE coupled with batch drilling operations and option to offline cement and/or remediate (if needed) any surface or intermediate sections, according to attached offline cementing support documentation.
- After the well section is secured, the BOP will be disconnected from the wellhead and walked with the rig to another well on the pad.
- TA cap will also be installed per Wellhead vendor procedure and pressure inside the casing will be monitored via the valve on the TA cap as per standard batch drilling ops.

Break Test Diagram (HCR valve)

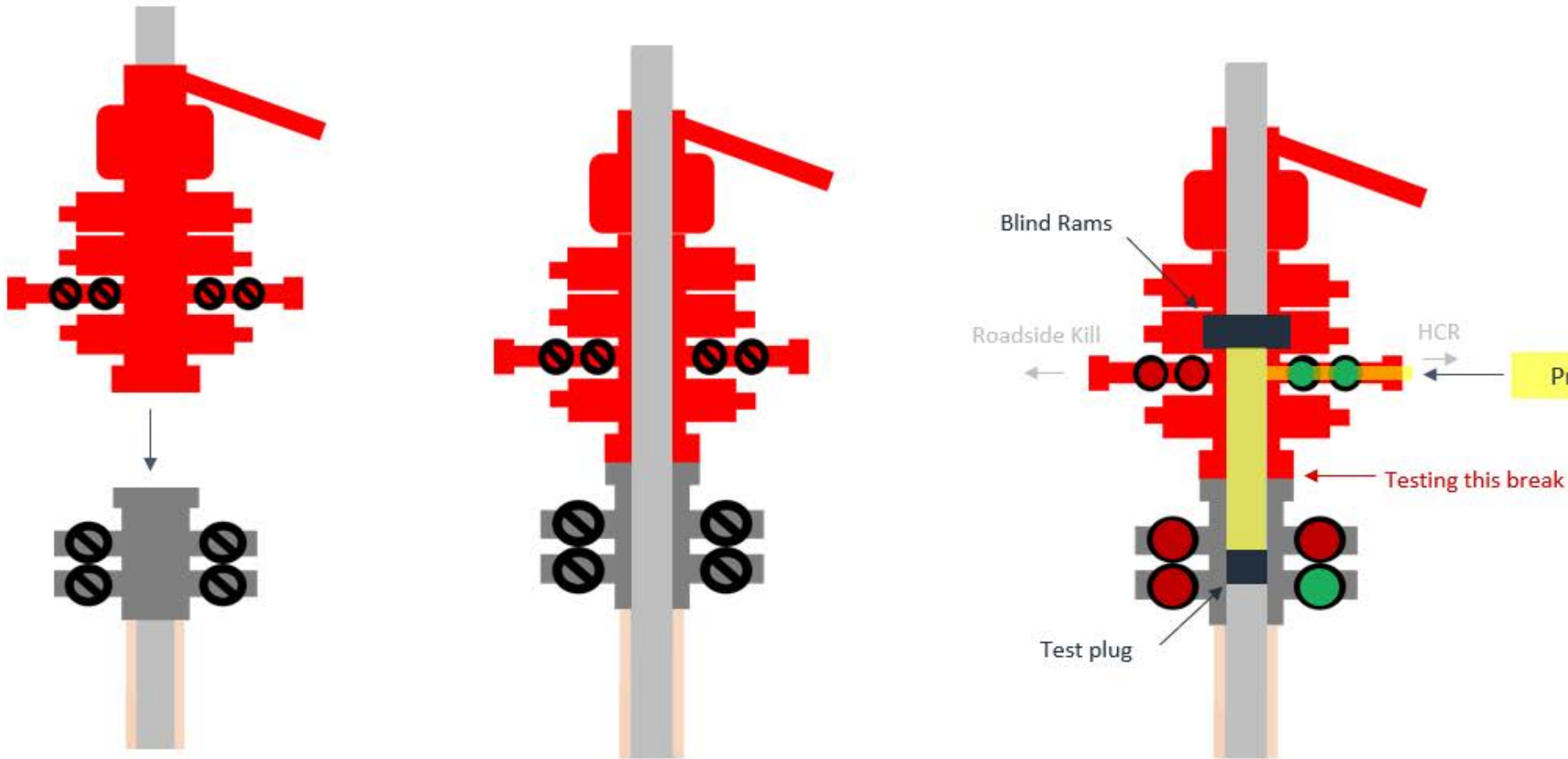

Steps

1. Set plug in wellhead (lower barrier)
2. Close Blind Rams (upper barrier)
3. Close roadside kill
4. Open HCR (pressure application)
5. Open wellhead valves below test plug to ensure if leak past test plug, pressure won't be applied to wellbore
6. Tie BOP testers high pressure line to main choke manifold crown valve
7. Pressure up to test break
8. Bleed test pressure from BOP testing unit

Break Test Diagram (Test Joint)

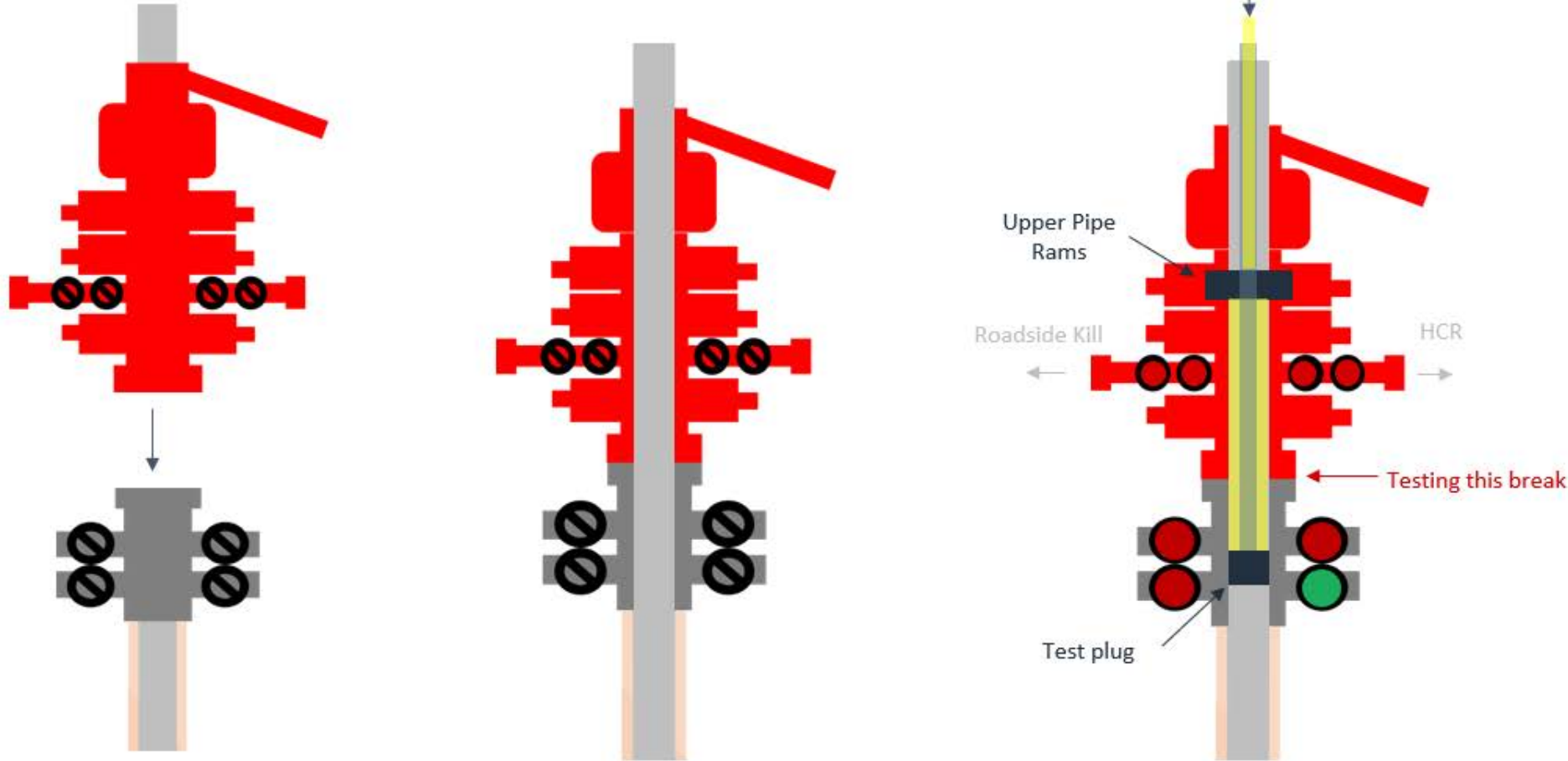

Steps

1. Set plug in with test joint wellhead (lower barrier)
2. Close Upper Pipe Rams (upper barrier)
3. Close roadside kill
4. Close HCR
5. Open wellhead valves below test plug to ensure if leak past test plug, pressure won't be applied to wellbore
6. Tie BOP testers high pressure line to top of test joint
7. Pressure up to test break
8. Bleed test pressure from BOP testing unit



Lavash 2 State Com #703H

Hydrogen Sulfide Plan Summary

- A. All personnel shall receive proper H2S training in accordance with Onshore Order III.C.3.a.**
- B. Briefing Area: two perpendicular areas will be designated by signs and readily accessible.**
- C. Required Emergency Equipment:**
- **Well control equipment**
 - a. Flare line 150' from wellhead to be ignited by flare gun.
 - b. Choke manifold with a remotely operated choke.
 - c. Mud/gas separator
 - **Protective equipment for essential personnel:**
 - a. Breathing Apparatus:
 - i. Rescue Packs (SCBA) — 1 unit shall be placed at each breathing area, 2 shall be stored in the safety trailer.
 - ii. Work/Escapes packs — 4 packs shall be stored on the rig floor with sufficient air hose not to restrict work activity.
 - iii. Emergency Escape Packs — 4 packs shall be stored in the doghouse for emergency evacuation.
 - b. Auxiliary Rescue Equipment:
 - i. Stretcher
 - ii. Two OSHA full body harness
 - iii. 100 ft 5/8 inch OSHA approved rope
 - iv. 1-20# class ABC fire extinguisher
 - **H2S Detection and Monitoring Equipment:**

The stationary detector with three sensors will be placed in the upper dog house if equipped, set to visually alarm @ 10 ppm and audible @ 14 ppm. Calibrate a minimum of every 30 days or as needed. The sensors will be placed in the following places: Rig floor / Bell nipple / End of flow line or where well bore fluid is being discharged. (Gas sample tubes will be stored in the safety trailer)
 - **Visual Warning System:**
 - a. One color code condition sign will be placed at the entrance to the site reflecting the possible conditions at the site.
 - b. A colored condition flag will be on display, reflecting the current condition at the site at the time.
 - c. Two wind socks will be placed in strategic locations, visible from all angles.



Lavash 2 State Com #703H

■ **Mud Program:**

The mud program has been designed to minimize the volume of H₂S circulated to surface. The operator will have the necessary mud products to minimize hazards while drilling in H₂S bearing zones.

■ **Metallurgy:**

All drill strings, casings, tubing, wellhead, blowout preventer, drilling spool, kill lines, choke manifold and lines, and valves shall be suitable for H₂S service.

■ **Communication:**

Communication will be via cell phones and land lines where available.



Lavash 2 State Com #703H

Emergency Assistance Telephone List

PUBLIC SAFETY:	911 or
Lea County Sheriff's Department	(575) 396-3611
Corey Helton	
Fire Department	
Carlsbad	(575) 885-3125
Artesia	(575) 746-5050
Hospitals	
Carlsbad	(575) 887-4121
Artesia	(575) 748-3333
Hobbs	(575) 392-1979
Dept. of Public Safety/Carlsbad	(575) 748-9718
Highway Department	(575) 885-3281
U.S. Department of Labor	(575) 887-1174
Bureau of Land Management - Hobbs (Lea Co)	(575) 393-3612
PET On Call - Hobbs	(575) 706-2779
Bureau of Land Management - Carlsbad (Eddy Co)	(575) 234-5972
PET On Call - Carlsbad	(575) 706-2779
New Mexico Oil Conservation Division - Artesia	(575) 748-1283
Inspection Group South - Gilbert Cordero	(575) 626-0830
EOG Resources, Inc.	
EOG Midland	(432) 686-3600
Drilling Manager	
Matt Day	(210) 296-4456
H&P Drilling	
H&P Drilling	(432) 563-5757
Nabors Drilling	
Nabors Drilling	(432) 363-8180
Patterson UTI	
Patterson UTI	(432) 561-9382
EOG Safety	
Brian Chandler (HSE Manager)	(817) 239-0251



Lavash 2 State Com #703H
EDDY County, New Mexico
Proposed Wellbore
Primary APD Design A

940' FSL
844' FWL
Section 2
T-26-S, R-28-E

KB: 2974'
GL: 2949'

API: 30-015-*****

Bit Size: 13"
10-3/4", 40.5#, J-55, STC
@ 0' - 2,600' MD
@ 0' - 2,600' TVD

Bit Size: 9-7/8"
8-5/8", 32.#, P110-HSCY, GB CD Butt 9.03
@ 0' - 9,171' MD
@ 0' - 9,048' TVD

Bit Size: 7-7/8" | Bit Size: 6-3/4"
6", 22.3#, P110-EC, DWC/C IS
@ 0' - 9,271' MD
@ 0' - 9,148' TVD
5-1/2", 20.#, P110-EC, DWC/C IS MS
@ 9,271' - 19,858' MD
@ 9,148' - 9,525' TVD

KOP: 9,171' MD, 9,048' TVD
EOC: 9,922' MD, 9,525' TVD

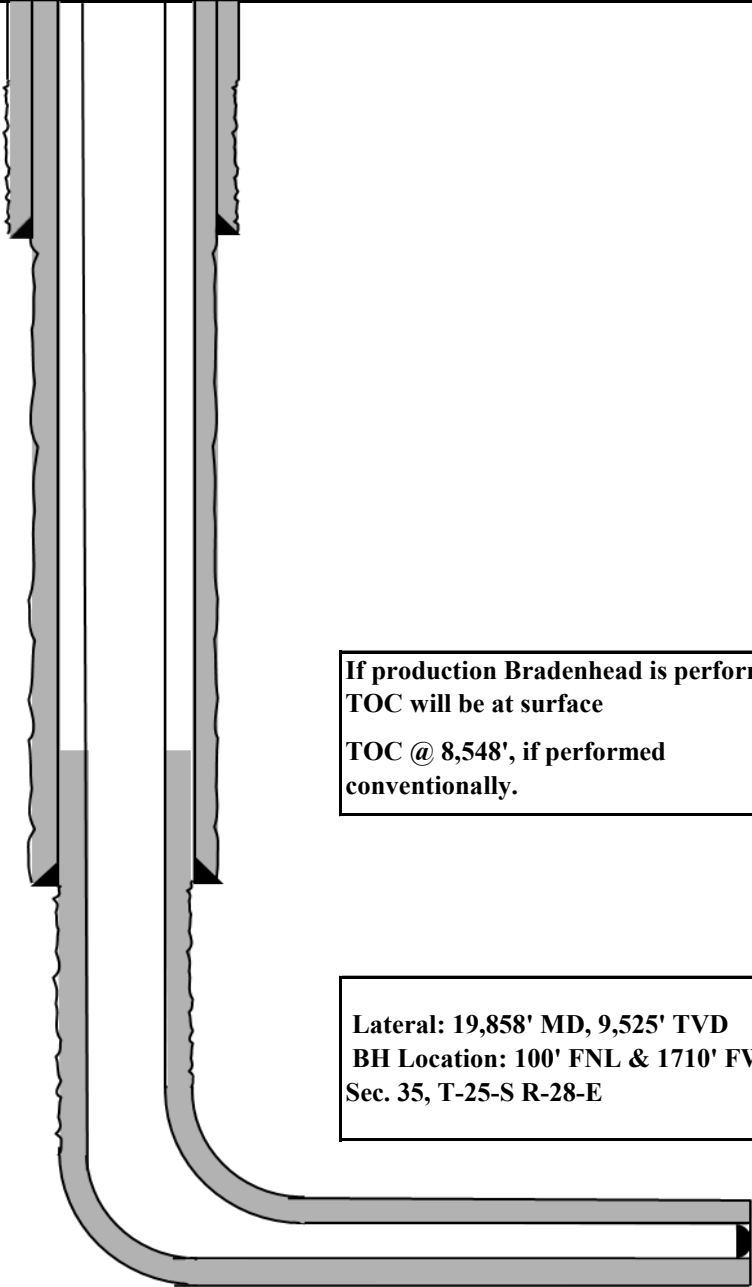

If production Bradenhead is performed,
TOC will be at surface
TOC @ 8,548', if performed
conventionally.

Lateral: 19,858' MD, 9,525' TVD
BH Location: 100' FNL & 1710' FWL
Sec. 35, T-25-S R-28-E



Lavash 2 State Com #703H

Permit Information:

Well Name: Lavash 2 State Com 703H

Location: SHL: 940' FSL & 844' FWL, Section 2, T-26-S, R-28-E, EDDY Co., N.M.

BHL: 100' FNL & 1710' FWL, Section 35, T-25-S, R-28-E, EDDY Co., N.M.

Casing Program Primary APD Design A:

Hole Size	Interval MD		Interval TVD		Csg OD	Weight	Grade	Conn
	From (ft)	To (ft)	From (ft)	To (ft)				
13"	0	2,600	0	2,600	10-3/4"	40.5#	J-55	STC
9-7/8"	0	9,171	0	9,048	8-5/8"	32#	P110-HSCY	GB CD Butt 9.03
7-7/8"	0	9,271	0	9,148	6"	22.3#	P110-EC	DWC/C IS
6-3/4"	9,271	19,858	9,148	9,525	5-1/2"	20#	P110-EC	DWC/C IS MS

**For highlighted rows above, variance is requested to run entire string of either 6" 22.3# P110-EC DWC/C IS or 5-1/2" 20# P110-EC DWC/C IS MS casing string above due to availability.

Cement Program:

Depth MD	No. Sacks	Wt. ppg	Yld Ft3/sk	Slurry Description
2,600'	600	13.5	1.73	Class C/H + additives (TOC @ Surface)
	70	14.8	1.34	Class C/H + additives
9,171'	650	14.2	1.11	1st Stage (Tail): Class C/H + additives (TOC @ 4,644')
	1000	14.8	1.5	2nd Stage (Bradenhead squeeze): Class C/H + additives (TOC @ surface)
19,858'	870	12.5	2.05	Lead: Class C/H + additives (TOC @ 8,548')
6" 5-1/2"	1700	13.2	1.47	Tail: Class C/H + additives (TOC @ 9,738')

Mud Program:

Depth	Type	Weight (ppg)	Viscosity	Water Loss
0 – 2,600'	Fresh - Gel	8.6-8.8	28-34	N/c
2,600' – 9,048'	Brine	9.8-10.8	28-34	N/c
9,048' – 9,171'	Water/Gel	8.7-9.4	58-68	N/c - 6
9,171' – 19,858' Lateral	Oil Base	10.0-14.0	58-68	4 - 6



Lavash 2 State Com #703H

TUBING REQUIREMENTS:

EOG respectfully requests an exception to the following NMOCD rule:

- 19.15.16.10 Casing AND TUBING REQUIREMENTS:
J (3): “The operator shall set tubing as near the bottom as practical and tubing perforations shall not be more than 250 feet above top of pay zone.”

With horizontal flowing and gas lifted wells an end of tubing depth placed at or slightly above KOP is a conservative way to ensure the tubing stays clean from debris, plugging, and allows for fewer well interventions post offset completion. The deeper the tubulars are run into the curve, the higher the probability is that the tubing will become stuck in sand and or well debris as the well produces over time. An additional consideration for EOT placement during artificial lift installations is avoiding the high dog leg severity and inclinations found in the curve section of the wellbore to help improve reliability and performance. Dog leg severity and inclinations tend not to hamper gas lifted or flowing wells, but they do effect other forms of artificial lift like rod pump or ESP (electric submersible pump). Keeping the EOT above KOP is an industry best practice for those respective forms of artificial lift.



Lavash 2 State Com #703H

Hydrogen Sulfide Plan Summary

A. All personnel shall receive proper H₂S training in accordance with Onshore Order III.C.3.a.

B. Briefing Area: two perpendicular areas will be designated by signs and readily accessible.

C. Required Emergency Equipment:

■ Well control equipment

- a. Flare line 150' from wellhead to be ignited by flare gun.
- b. Choke manifold with a remotely operated choke.
- c. Mud/gas separator

■ Protective equipment for essential personnel.

Breathing apparatus:

- a. Rescue Packs (SCBA) — 1 unit shall be placed at each breathing area, 2 shall be stored in the safety trailer.
- b. Work/Escape packs — 4 packs shall be stored on the rig floor with sufficient air hose not to restrict work activity.
- c. Emergency Escape Packs — 4 packs shall be stored in the doghouse for emergency evacuation.

Auxiliary Rescue Equipment:

- a. Stretcher
- b. Two OSHA full body harness
- c. 100 ft 5/8 inch OSHA approved rope
- d. 1-20# class ABC fire extinguisher

■ H₂S detection and monitoring equipment:

The stationary detector with three sensors will be placed in the upper dog house if equipped, set to visually alarm @ 10 ppm and audible @ 14 ppm. Calibrate a minimum of every 30 days or as needed. The sensors will be placed in the following places: Rig floor / Bell nipple / End of flow line or where well bore fluid is being discharged.

(Gas sample tubes will be stored in the safety trailer)

■ Visual warning systems.

- a. One color code condition sign will be placed at the entrance to the site reflecting the possible conditions at the site.
- b. A colored condition flag will be on display, reflecting the current condition at the site at the time.
- c. Two wind socks will be placed in strategic locations, visible from all angles.



Lavash 2 State Com #703H

■ Mud program:

The mud program has been designed to minimize the volume of H₂S circulated to surface. The operator will have the necessary mud products to minimize hazards while drilling in H₂S bearing zones.

■ Metallurgy:

All drill strings, casings, tubing, wellhead, blowout preventer, drilling spool, kill lines, choke manifold and lines, and valves shall be suitable for H₂S service.

■ Communication:

Communication will be via cell phones and land lines where available.



**Lavash 2 State Com #703H
Emergency Assistance Telephone List**

PUBLIC SAFETY:		911 or
Lea County Sheriff's Department		(575) 396-3611
Rod Coffman		
Fire Department:		
Carlsbad		(575) 885-3125
Artesia		(575) 746-5050
Hospitals:		
Carlsbad		(575) 887-4121
Artesia		(575) 748-3333
Hobbs		(575) 392-1979
Dept. of Public Safety/Carlsbad		(575) 748-9718
Highway Department		(575) 885-3281
New Mexico Oil Conservation		(575) 476-3440
NMOCD Inspection Group - South		(575) 626-0830
U.S. Dept. of Labor		(575) 887-1174
EOG Resources, Inc.		
EOG / Midland	Office	(432) 686-3600
Safety:		
Brian Chandler (HSE Manager)	Office	(432) 686-3695
	Cell	(817) 239-0251
H&P Drilling		
H&P Drilling	Office	(432) 563-5757
H&P 651 Drilling Rig	Rig	(903) 509-7131



Lavash 2 State Com #703H

GEOLOGIC NAME OF SURFACE FORMATION:

Permian

ESTIMATED TOPS OF IMPORTANT GEOLOGICAL MARKERS:

Rustler	'
Tamarisk Anhydrite	'
Top of Salt	256'
Base of Salt	2,483'
Lamar	2,675'
Bell Canyon	2,701'
Cherry Canyon	3,556'
Brushy Canyon	4,844'
Bone Spring Lime	6,399'
Leonard (Avalon) Shale	6,469'
1st Bone Spring Sand	7,378'
2nd Bone Spring Shale	7,564'
2nd Bone Spring Sand	8,025'
3rd Bone Spring Carb	8,507'
3rd Bone Spring Sand	9,176'
Wolfcamp	9,545'
TD	9,525'

ESTIMATED DEPTHS OF ANTICIPATED FRESH WATER, OIL OR GAS:

Upper Permian Sands	0- 400'	Fresh Water
Lamar	2,675'	Oil
Cherry Canyon	3,556'	Oil
Brushy Canyon	4,844'	Oil
Bone Spring Lime	6,399'	Oil
Leonard (Avalon) Shale	6,469'	Oil
1st Bone Spring Sand	7,378'	Oil
2nd Bone Spring Shale	7,564'	Oil
2nd Bone Spring Sand	8,025'	Oil
3rd Bone Spring Carb	8,507'	Oil
3rd Bone Spring Sand	9,176'	Oil
Wolfcamp	9,545'	Oil

Midland

Eddy County, NM (NAD 83 NME)

Lavash 2 State Com

#703H

OH

Plan: Plan #0.1 RT

Standard Planning Report

05 March, 2026

Planning Report

Database:	EDT_18	Local Co-ordinate Reference:	Well #703H
Company:	Midland	TVD Reference:	kb = 26' @ 2975.0usft
Project:	Eddy County, NM (NAD 83 NME)	MD Reference:	kb = 26' @ 2975.0usft
Site:	Lavash 2 State Com	North Reference:	Grid
Well:	#703H	Survey Calculation Method:	Minimum Curvature
Wellbore:	OH		
Design:	Plan #0.1 RT		

Project	Eddy County, NM (NAD 83 NME)		
Map System:	US State Plane 1983	System Datum:	Mean Sea Level
Geo Datum:	North American Datum 1983		
Map Zone:	New Mexico Eastern Zone		

Site	Lavash 2 State Com				
Site Position:		Northing:	388,256.00 usft	Latitude:	32° 4' 1.533 N
From:	Map	Easting:	627,192.00 usft	Longitude:	104° 3' 22.216 W
Position Uncertainty:	0.0 usft	Slot Radius:	13-3/16 "		

Well	#703H					
Well Position	+N/-S	0.0 usft	Northing:	388,237.00 usft	Latitude:	32° 4' 1.403 N
	+E/-W	0.0 usft	Easting:	624,873.00 usft	Longitude:	104° 3' 49.167 W
Position Uncertainty	0.0 usft		Wellhead Elevation:	usft	Ground Level:	2,949.0 usft
Grid Convergence:	0.14 °					

Wellbore	OH				
Magnetics	Model Name	Sample Date	Declination	Dip Angle	Field Strength
			(°)	(°)	(nT)
	IGRF2025	3/5/2026	6.41	59.52	46,798.92672540

Design	Plan #0.1 RT			
Audit Notes:				
Version:	Phase:	PLAN	Tie On Depth:	0.0
Vertical Section:	Depth From (TVD)	+N/-S	+E/-W	Direction
	(usft)	(usft)	(usft)	(°)
	0.0	0.0	0.0	5.21

Plan Survey Tool Program	Date	3/5/2026		
Depth From	Depth To	Survey (Wellbore)	Tool Name	Remarks
(usft)	(usft)			
1	0.0	19,857.9 Plan #0.1 RT (OH)	EOG MWD+IFR1	
			MWD + IFR1	

Planning Report

Database:	EDT_18	Local Co-ordinate Reference:	Well #703H
Company:	Midland	TVD Reference:	kb = 26' @ 2975.0usft
Project:	Eddy County, NM (NAD 83 NME)	MD Reference:	kb = 26' @ 2975.0usft
Site:	Lavash 2 State Com	North Reference:	Grid
Well:	#703H	Survey Calculation Method:	Minimum Curvature
Wellbore:	OH		
Design:	Plan #0.1 RT		

Plan Sections										
Measured Depth (usft)	Inclination (°)	Azimuth (°)	Vertical Depth (usft)	+N/-S (usft)	+E/-W (usft)	Dogleg Rate (°/100usft)	Build Rate (°/100usft)	Turn Rate (°/100usft)	TFO (°)	Target
0.0	0.00	0.00	0.0	0.0	0.0	0.00	0.00	0.00	0.00	
2,483.0	0.00	0.00	2,483.0	0.0	0.0	0.00	0.00	0.00	0.00	
3,073.2	11.80	135.03	3,069.0	-42.9	42.8	2.00	2.00	0.00	135.03	
8,533.6	11.80	135.03	8,414.0	-833.1	832.2	0.00	0.00	0.00	0.00	
9,123.8	0.00	0.00	9,000.0	-876.0	875.0	2.00	-2.00	0.00	180.00	
9,171.3	0.00	0.00	9,047.5	-876.0	875.0	0.00	0.00	0.00	0.00	KOP(Lavash 2 State C
9,717.8	65.56	359.39	9,482.3	-596.0	872.0	12.00	12.00	-0.11	359.39	FTP(Lavash 2 State C
9,921.5	90.00	0.00	9,525.1	-398.4	871.0	12.00	12.00	0.30	1.48	
14,653.9	90.00	0.00	9,525.0	4,334.0	871.0	0.00	0.00	0.00	0.00	Fed Perf 1(Lavash 2 S
19,857.9	90.00	359.98	9,525.0	9,538.0	870.0	0.00	0.00	0.00	-95.14	PBHL(Lavash 2 State

Planning Report

Database:	EDT_18	Local Co-ordinate Reference:	Well #703H
Company:	Midland	TVD Reference:	kb = 26' @ 2975.0usft
Project:	Eddy County, NM (NAD 83 NME)	MD Reference:	kb = 26' @ 2975.0usft
Site:	Lavash 2 State Com	North Reference:	Grid
Well:	#703H	Survey Calculation Method:	Minimum Curvature
Wellbore:	OH		
Design:	Plan #0.1 RT		

Planned Survey									
Measured Depth (usft)	Inclination (°)	Azimuth (°)	Vertical Depth (usft)	+N/-S (usft)	+E/-W (usft)	Vertical Section (usft)	Dogleg Rate (°/100usft)	Build Rate (°/100usft)	Turn Rate (°/100usft)
0.0	0.00	0.00	0.0	0.0	0.0	0.0	0.00	0.00	0.00
100.0	0.00	0.00	100.0	0.0	0.0	0.0	0.00	0.00	0.00
200.0	0.00	0.00	200.0	0.0	0.0	0.0	0.00	0.00	0.00
300.0	0.00	0.00	300.0	0.0	0.0	0.0	0.00	0.00	0.00
400.0	0.00	0.00	400.0	0.0	0.0	0.0	0.00	0.00	0.00
500.0	0.00	0.00	500.0	0.0	0.0	0.0	0.00	0.00	0.00
600.0	0.00	0.00	600.0	0.0	0.0	0.0	0.00	0.00	0.00
700.0	0.00	0.00	700.0	0.0	0.0	0.0	0.00	0.00	0.00
800.0	0.00	0.00	800.0	0.0	0.0	0.0	0.00	0.00	0.00
900.0	0.00	0.00	900.0	0.0	0.0	0.0	0.00	0.00	0.00
1,000.0	0.00	0.00	1,000.0	0.0	0.0	0.0	0.00	0.00	0.00
1,100.0	0.00	0.00	1,100.0	0.0	0.0	0.0	0.00	0.00	0.00
1,200.0	0.00	0.00	1,200.0	0.0	0.0	0.0	0.00	0.00	0.00
1,300.0	0.00	0.00	1,300.0	0.0	0.0	0.0	0.00	0.00	0.00
1,400.0	0.00	0.00	1,400.0	0.0	0.0	0.0	0.00	0.00	0.00
1,500.0	0.00	0.00	1,500.0	0.0	0.0	0.0	0.00	0.00	0.00
1,600.0	0.00	0.00	1,600.0	0.0	0.0	0.0	0.00	0.00	0.00
1,700.0	0.00	0.00	1,700.0	0.0	0.0	0.0	0.00	0.00	0.00
1,800.0	0.00	0.00	1,800.0	0.0	0.0	0.0	0.00	0.00	0.00
1,900.0	0.00	0.00	1,900.0	0.0	0.0	0.0	0.00	0.00	0.00
2,000.0	0.00	0.00	2,000.0	0.0	0.0	0.0	0.00	0.00	0.00
2,100.0	0.00	0.00	2,100.0	0.0	0.0	0.0	0.00	0.00	0.00
2,200.0	0.00	0.00	2,200.0	0.0	0.0	0.0	0.00	0.00	0.00
2,300.0	0.00	0.00	2,300.0	0.0	0.0	0.0	0.00	0.00	0.00
2,400.0	0.00	0.00	2,400.0	0.0	0.0	0.0	0.00	0.00	0.00
2,483.0	0.00	0.00	2,483.0	0.0	0.0	0.0	0.00	0.00	0.00
2,500.0	0.34	135.03	2,500.0	0.0	0.0	0.0	2.00	2.00	0.00
2,600.0	2.34	135.03	2,600.0	-1.7	1.7	-1.5	2.00	2.00	0.00
2,700.0	4.34	135.03	2,699.8	-5.8	5.8	-5.3	2.00	2.00	0.00
2,800.0	6.34	135.03	2,799.4	-12.4	12.4	-11.2	2.00	2.00	0.00
2,900.0	8.34	135.03	2,898.5	-21.4	21.4	-19.4	2.00	2.00	0.00
3,000.0	10.34	135.03	2,997.2	-32.9	32.9	-29.8	2.00	2.00	0.00
3,073.2	11.80	135.03	3,069.0	-42.9	42.8	-38.8	2.00	2.00	0.00
3,100.0	11.80	135.03	3,095.3	-46.7	46.7	-42.3	0.00	0.00	0.00
3,200.0	11.80	135.03	3,193.2	-61.2	61.1	-55.4	0.00	0.00	0.00
3,300.0	11.80	135.03	3,291.0	-75.7	75.6	-68.5	0.00	0.00	0.00
3,400.0	11.80	135.03	3,388.9	-90.2	90.1	-81.6	0.00	0.00	0.00
3,500.0	11.80	135.03	3,486.8	-104.6	104.5	-94.7	0.00	0.00	0.00
3,600.0	11.80	135.03	3,584.7	-119.1	119.0	-107.8	0.00	0.00	0.00
3,700.0	11.80	135.03	3,682.6	-133.6	133.4	-120.9	0.00	0.00	0.00
3,800.0	11.80	135.03	3,780.5	-148.1	147.9	-134.0	0.00	0.00	0.00
3,900.0	11.80	135.03	3,878.4	-162.5	162.3	-147.1	0.00	0.00	0.00
4,000.0	11.80	135.03	3,976.2	-177.0	176.8	-160.2	0.00	0.00	0.00
4,100.0	11.80	135.03	4,074.1	-191.5	191.3	-173.3	0.00	0.00	0.00
4,200.0	11.80	135.03	4,172.0	-205.9	205.7	-186.4	0.00	0.00	0.00
4,300.0	11.80	135.03	4,269.9	-220.4	220.2	-199.5	0.00	0.00	0.00
4,400.0	11.80	135.03	4,367.8	-234.9	234.6	-212.6	0.00	0.00	0.00
4,500.0	11.80	135.03	4,465.7	-249.4	249.1	-225.7	0.00	0.00	0.00
4,600.0	11.80	135.03	4,563.5	-263.8	263.5	-238.8	0.00	0.00	0.00
4,700.0	11.80	135.03	4,661.4	-278.3	278.0	-251.9	0.00	0.00	0.00
4,800.0	11.80	135.03	4,759.3	-292.8	292.4	-265.0	0.00	0.00	0.00
4,900.0	11.80	135.03	4,857.2	-307.3	306.9	-278.1	0.00	0.00	0.00
5,000.0	11.80	135.03	4,955.1	-321.7	321.4	-291.2	0.00	0.00	0.00
5,100.0	11.80	135.03	5,053.0	-336.2	335.8	-304.3	0.00	0.00	0.00

Planning Report

Database:	EDT_18	Local Co-ordinate Reference:	Well #703H
Company:	Midland	TVD Reference:	kb = 26' @ 2975.0usft
Project:	Eddy County, NM (NAD 83 NME)	MD Reference:	kb = 26' @ 2975.0usft
Site:	Lavash 2 State Com	North Reference:	Grid
Well:	#703H	Survey Calculation Method:	Minimum Curvature
Wellbore:	OH		
Design:	Plan #0.1 RT		

Planned Survey										
Measured Depth (usft)	Inclination (°)	Azimuth (°)	Vertical Depth (usft)	+N/-S (usft)	+E/-W (usft)	Vertical Section (usft)	Dogleg Rate (°/100usft)	Build Rate (°/100usft)	Turn Rate (°/100usft)	
5,200.0	11.80	135.03	5,150.9	-350.7	350.3	-317.4	0.00	0.00	0.00	
5,300.0	11.80	135.03	5,248.7	-365.1	364.7	-330.5	0.00	0.00	0.00	
5,400.0	11.80	135.03	5,346.6	-379.6	379.2	-343.6	0.00	0.00	0.00	
5,500.0	11.80	135.03	5,444.5	-394.1	393.6	-356.7	0.00	0.00	0.00	
5,600.0	11.80	135.03	5,542.4	-408.6	408.1	-369.8	0.00	0.00	0.00	
5,700.0	11.80	135.03	5,640.3	-423.0	422.6	-382.9	0.00	0.00	0.00	
5,800.0	11.80	135.03	5,738.2	-437.5	437.0	-396.0	0.00	0.00	0.00	
5,900.0	11.80	135.03	5,836.1	-452.0	451.5	-409.1	0.00	0.00	0.00	
6,000.0	11.80	135.03	5,933.9	-466.5	465.9	-422.2	0.00	0.00	0.00	
6,100.0	11.80	135.03	6,031.8	-480.9	480.4	-435.3	0.00	0.00	0.00	
6,200.0	11.80	135.03	6,129.7	-495.4	494.8	-448.4	0.00	0.00	0.00	
6,300.0	11.80	135.03	6,227.6	-509.9	509.3	-461.5	0.00	0.00	0.00	
6,400.0	11.80	135.03	6,325.5	-524.3	523.7	-474.6	0.00	0.00	0.00	
6,500.0	11.80	135.03	6,423.4	-538.8	538.2	-487.7	0.00	0.00	0.00	
6,600.0	11.80	135.03	6,521.3	-553.3	552.7	-500.8	0.00	0.00	0.00	
6,700.0	11.80	135.03	6,619.1	-567.8	567.1	-513.9	0.00	0.00	0.00	
6,800.0	11.80	135.03	6,717.0	-582.2	581.6	-527.0	0.00	0.00	0.00	
6,900.0	11.80	135.03	6,814.9	-596.7	596.0	-540.1	0.00	0.00	0.00	
7,000.0	11.80	135.03	6,912.8	-611.2	610.5	-553.2	0.00	0.00	0.00	
7,100.0	11.80	135.03	7,010.7	-625.7	624.9	-566.3	0.00	0.00	0.00	
7,200.0	11.80	135.03	7,108.6	-640.1	639.4	-579.4	0.00	0.00	0.00	
7,300.0	11.80	135.03	7,206.5	-654.6	653.9	-592.5	0.00	0.00	0.00	
7,400.0	11.80	135.03	7,304.3	-669.1	668.3	-605.6	0.00	0.00	0.00	
7,500.0	11.80	135.03	7,402.2	-683.5	682.8	-618.7	0.00	0.00	0.00	
7,600.0	11.80	135.03	7,500.1	-698.0	697.2	-631.8	0.00	0.00	0.00	
7,700.0	11.80	135.03	7,598.0	-712.5	711.7	-644.9	0.00	0.00	0.00	
7,800.0	11.80	135.03	7,695.9	-727.0	726.1	-658.0	0.00	0.00	0.00	
7,900.0	11.80	135.03	7,793.8	-741.4	740.6	-671.1	0.00	0.00	0.00	
8,000.0	11.80	135.03	7,891.7	-755.9	755.0	-684.2	0.00	0.00	0.00	
8,100.0	11.80	135.03	7,989.5	-770.4	769.5	-697.3	0.00	0.00	0.00	
8,200.0	11.80	135.03	8,087.4	-784.9	784.0	-710.4	0.00	0.00	0.00	
8,300.0	11.80	135.03	8,185.3	-799.3	798.4	-723.5	0.00	0.00	0.00	
8,400.0	11.80	135.03	8,283.2	-813.8	812.9	-736.6	0.00	0.00	0.00	
8,500.0	11.80	135.03	8,381.1	-828.3	827.3	-749.7	0.00	0.00	0.00	
8,533.6	11.80	135.03	8,414.0	-833.1	832.2	-754.1	0.00	0.00	0.00	
8,600.0	10.48	135.03	8,479.1	-842.2	841.3	-762.3	2.00	-2.00	0.00	
8,700.0	8.48	135.03	8,577.7	-853.9	852.9	-772.9	2.00	-2.00	0.00	
8,800.0	6.48	135.03	8,676.9	-863.1	862.1	-781.2	2.00	-2.00	0.00	
8,900.0	4.48	135.03	8,776.4	-869.8	868.8	-787.3	2.00	-2.00	0.00	
9,000.0	2.48	135.03	8,876.2	-874.1	873.1	-791.2	2.00	-2.00	0.00	
9,100.0	0.48	135.03	8,976.2	-875.9	874.9	-792.8	2.00	-2.00	0.00	
9,123.8	0.00	0.00	9,000.0	-876.0	875.0	-792.9	2.00	-2.00	0.00	
9,171.3	0.00	0.00	9,047.5	-876.0	875.0	-792.9	0.00	0.00	0.00	
9,175.0	0.44	359.39	9,051.2	-876.0	875.0	-792.9	12.00	12.00	0.00	
9,200.0	3.44	359.39	9,076.2	-875.1	875.0	-792.0	12.00	12.00	0.00	
9,225.0	6.44	359.39	9,101.1	-873.0	875.0	-789.9	12.00	12.00	0.00	
9,250.0	9.44	359.39	9,125.8	-869.5	874.9	-786.5	12.00	12.00	0.00	
9,275.0	12.44	359.39	9,150.4	-864.8	874.9	-781.7	12.00	12.00	0.00	
9,300.0	15.44	359.39	9,174.6	-858.8	874.8	-775.7	12.00	12.00	0.00	
9,325.0	18.44	359.39	9,198.6	-851.5	874.7	-768.5	12.00	12.00	0.00	
9,350.0	21.44	359.39	9,222.1	-843.0	874.6	-760.0	12.00	12.00	0.00	
9,375.0	24.44	359.39	9,245.1	-833.2	874.5	-750.3	12.00	12.00	0.00	
9,400.0	27.44	359.39	9,267.6	-822.3	874.4	-739.5	12.00	12.00	0.00	
9,425.0	30.44	359.39	9,289.4	-810.2	874.3	-727.4	12.00	12.00	0.00	

Planning Report

Database:	EDT_18	Local Co-ordinate Reference:	Well #703H
Company:	Midland	TVD Reference:	kb = 26' @ 2975.0usft
Project:	Eddy County, NM (NAD 83 NME)	MD Reference:	kb = 26' @ 2975.0usft
Site:	Lavash 2 State Com	North Reference:	Grid
Well:	#703H	Survey Calculation Method:	Minimum Curvature
Wellbore:	OH		
Design:	Plan #0.1 RT		

Planned Survey									
Measured Depth (usft)	Inclination (°)	Azimuth (°)	Vertical Depth (usft)	+N/-S (usft)	+E/-W (usft)	Vertical Section (usft)	Dogleg Rate (°/100usft)	Build Rate (°/100usft)	Turn Rate (°/100usft)
9,450.0	33.44	359.39	9,310.6	-797.0	874.2	-714.3	12.00	12.00	0.00
9,475.0	36.44	359.39	9,331.1	-782.7	874.0	-700.0	12.00	12.00	0.00
9,500.0	39.43	359.39	9,350.9	-767.3	873.8	-684.7	12.00	12.00	0.00
9,525.0	42.43	359.39	9,369.7	-750.9	873.7	-668.4	12.00	12.00	0.00
9,550.0	45.43	359.39	9,387.7	-733.6	873.5	-651.2	12.00	12.00	0.00
9,575.0	48.43	359.39	9,404.8	-715.3	873.3	-633.0	12.00	12.00	0.00
9,600.0	51.43	359.39	9,420.9	-696.2	873.1	-614.0	12.00	12.00	0.00
9,625.0	54.43	359.39	9,436.0	-676.2	872.9	-594.1	12.00	12.00	0.00
9,650.0	57.43	359.39	9,450.0	-655.5	872.6	-573.5	12.00	12.00	0.00
9,675.0	60.43	359.39	9,462.9	-634.1	872.4	-552.2	12.00	12.00	0.00
9,700.0	63.43	359.39	9,474.6	-612.1	872.2	-530.3	12.00	12.00	0.00
9,717.8	65.56	359.39	9,482.3	-596.0	872.0	-514.3	12.00	12.00	0.00
9,725.0	66.43	359.41	9,485.2	-589.4	871.9	-507.8	12.00	12.00	0.34
9,750.0	69.43	359.49	9,494.6	-566.3	871.7	-484.7	12.00	12.00	0.33
9,775.0	72.43	359.57	9,502.8	-542.6	871.5	-461.2	12.00	12.00	0.32
9,800.0	75.43	359.65	9,509.7	-518.6	871.4	-437.3	12.00	12.00	0.31
9,825.0	78.42	359.72	9,515.4	-494.3	871.2	-413.1	12.00	12.00	0.30
9,850.0	81.42	359.80	9,519.7	-469.7	871.1	-388.6	12.00	12.00	0.29
9,875.0	84.42	359.87	9,522.8	-444.8	871.0	-363.9	12.00	12.00	0.29
9,900.0	87.42	359.94	9,524.6	-419.9	871.0	-339.1	12.00	12.00	0.28
9,921.5	90.00	0.00	9,525.1	-398.4	871.0	-317.7	12.00	12.00	0.28
10,000.0	90.00	0.00	9,525.1	-319.9	871.0	-239.5	0.00	0.00	0.00
10,100.0	90.00	0.00	9,525.1	-219.9	871.0	-139.9	0.00	0.00	0.00
10,200.0	90.00	0.00	9,525.1	-119.9	871.0	-40.3	0.00	0.00	0.00
10,300.0	90.00	0.00	9,525.1	-19.9	871.0	59.3	0.00	0.00	0.00
10,400.0	90.00	0.00	9,525.1	80.1	871.0	158.9	0.00	0.00	0.00
10,500.0	90.00	0.00	9,525.1	180.1	871.0	258.5	0.00	0.00	0.00
10,600.0	90.00	0.00	9,525.1	280.1	871.0	358.0	0.00	0.00	0.00
10,700.0	90.00	0.00	9,525.1	380.1	871.0	457.6	0.00	0.00	0.00
10,800.0	90.00	0.00	9,525.1	480.1	871.0	557.2	0.00	0.00	0.00
10,900.0	90.00	0.00	9,525.1	580.1	871.0	656.8	0.00	0.00	0.00
11,000.0	90.00	0.00	9,525.1	680.1	871.0	756.4	0.00	0.00	0.00
11,100.0	90.00	0.00	9,525.1	780.1	871.0	856.0	0.00	0.00	0.00
11,200.0	90.00	0.00	9,525.1	880.1	871.0	955.6	0.00	0.00	0.00
11,300.0	90.00	0.00	9,525.1	980.1	871.0	1,055.1	0.00	0.00	0.00
11,400.0	90.00	0.00	9,525.1	1,080.1	871.0	1,154.7	0.00	0.00	0.00
11,500.0	90.00	0.00	9,525.1	1,180.1	871.0	1,254.3	0.00	0.00	0.00
11,600.0	90.00	0.00	9,525.1	1,280.1	871.0	1,353.9	0.00	0.00	0.00
11,700.0	90.00	0.00	9,525.1	1,380.1	871.0	1,453.5	0.00	0.00	0.00
11,800.0	90.00	0.00	9,525.0	1,480.1	871.0	1,553.1	0.00	0.00	0.00
11,900.0	90.00	0.00	9,525.0	1,580.1	871.0	1,652.7	0.00	0.00	0.00
12,000.0	90.00	0.00	9,525.0	1,680.1	871.0	1,752.3	0.00	0.00	0.00
12,100.0	90.00	0.00	9,525.0	1,780.1	871.0	1,851.8	0.00	0.00	0.00
12,200.0	90.00	0.00	9,525.0	1,880.1	871.0	1,951.4	0.00	0.00	0.00
12,300.0	90.00	0.00	9,525.0	1,980.1	871.0	2,051.0	0.00	0.00	0.00
12,400.0	90.00	0.00	9,525.0	2,080.1	871.0	2,150.6	0.00	0.00	0.00
12,500.0	90.00	0.00	9,525.0	2,180.1	871.0	2,250.2	0.00	0.00	0.00
12,600.0	90.00	0.00	9,525.0	2,280.1	871.0	2,349.8	0.00	0.00	0.00
12,700.0	90.00	0.00	9,525.0	2,380.1	871.0	2,449.4	0.00	0.00	0.00
12,800.0	90.00	0.00	9,525.0	2,480.1	871.0	2,548.9	0.00	0.00	0.00
12,900.0	90.00	0.00	9,525.0	2,580.1	871.0	2,648.5	0.00	0.00	0.00
13,000.0	90.00	0.00	9,525.0	2,680.1	871.0	2,748.1	0.00	0.00	0.00
13,100.0	90.00	0.00	9,525.0	2,780.1	871.0	2,847.7	0.00	0.00	0.00
13,200.0	90.00	0.00	9,525.0	2,880.1	871.0	2,947.3	0.00	0.00	0.00

Planning Report

Database:	EDT_18	Local Co-ordinate Reference:	Well #703H
Company:	Midland	TVD Reference:	kb = 26' @ 2975.0usft
Project:	Eddy County, NM (NAD 83 NME)	MD Reference:	kb = 26' @ 2975.0usft
Site:	Lavash 2 State Com	North Reference:	Grid
Well:	#703H	Survey Calculation Method:	Minimum Curvature
Wellbore:	OH		
Design:	Plan #0.1 RT		

Planned Survey										
Measured Depth (usft)	Inclination (°)	Azimuth (°)	Vertical Depth (usft)	+N/-S (usft)	+E/-W (usft)	Vertical Section (usft)	Dogleg Rate (°/100usft)	Build Rate (°/100usft)	Turn Rate (°/100usft)	
13,300.0	90.00	0.00	9,525.0	2,980.1	871.0	3,046.9	0.00	0.00	0.00	
13,400.0	90.00	0.00	9,525.0	3,080.1	871.0	3,146.5	0.00	0.00	0.00	
13,500.0	90.00	0.00	9,525.0	3,180.1	871.0	3,246.1	0.00	0.00	0.00	
13,600.0	90.00	0.00	9,525.0	3,280.1	871.0	3,345.6	0.00	0.00	0.00	
13,700.0	90.00	0.00	9,525.0	3,380.1	871.0	3,445.2	0.00	0.00	0.00	
13,800.0	90.00	0.00	9,525.0	3,480.1	871.0	3,544.8	0.00	0.00	0.00	
13,900.0	90.00	0.00	9,525.0	3,580.1	871.0	3,644.4	0.00	0.00	0.00	
14,000.0	90.00	0.00	9,525.0	3,680.1	871.0	3,744.0	0.00	0.00	0.00	
14,100.0	90.00	0.00	9,525.0	3,780.1	871.0	3,843.6	0.00	0.00	0.00	
14,200.0	90.00	0.00	9,525.0	3,880.1	871.0	3,943.2	0.00	0.00	0.00	
14,300.0	90.00	0.00	9,525.0	3,980.1	871.0	4,042.7	0.00	0.00	0.00	
14,400.0	90.00	0.00	9,525.0	4,080.1	871.0	4,142.3	0.00	0.00	0.00	
14,500.0	90.00	0.00	9,525.0	4,180.1	871.0	4,241.9	0.00	0.00	0.00	
14,600.0	90.00	0.00	9,525.0	4,280.1	871.0	4,341.5	0.00	0.00	0.00	
14,653.9	90.00	0.00	9,525.0	4,334.0	871.0	4,395.2	0.00	0.00	0.00	
14,700.0	90.00	360.00	9,525.0	4,380.1	871.0	4,441.1	0.00	0.00	0.00	
14,800.0	90.00	360.00	9,525.0	4,480.1	871.0	4,540.7	0.00	0.00	0.00	
14,900.0	90.00	360.00	9,525.0	4,580.1	871.0	4,640.3	0.00	0.00	0.00	
15,000.0	90.00	360.00	9,525.0	4,680.1	871.0	4,739.9	0.00	0.00	0.00	
15,100.0	90.00	360.00	9,525.0	4,780.1	871.0	4,839.4	0.00	0.00	0.00	
15,200.0	90.00	360.00	9,525.0	4,880.1	871.0	4,939.0	0.00	0.00	0.00	
15,300.0	90.00	360.00	9,525.0	4,980.1	871.0	5,038.6	0.00	0.00	0.00	
15,400.0	90.00	360.00	9,525.0	5,080.1	871.0	5,138.2	0.00	0.00	0.00	
15,500.0	90.00	360.00	9,525.0	5,180.1	871.0	5,237.8	0.00	0.00	0.00	
15,600.0	90.00	360.00	9,525.0	5,280.1	871.0	5,337.4	0.00	0.00	0.00	
15,700.0	90.00	360.00	9,525.0	5,380.1	871.0	5,437.0	0.00	0.00	0.00	
15,800.0	90.00	360.00	9,525.0	5,480.1	871.0	5,536.5	0.00	0.00	0.00	
15,900.0	90.00	359.99	9,525.0	5,580.1	870.9	5,636.1	0.00	0.00	0.00	
16,000.0	90.00	359.99	9,525.0	5,680.1	870.9	5,735.7	0.00	0.00	0.00	
16,100.0	90.00	359.99	9,525.0	5,780.1	870.9	5,835.3	0.00	0.00	0.00	
16,200.0	90.00	359.99	9,525.0	5,880.1	870.9	5,934.9	0.00	0.00	0.00	
16,300.0	90.00	359.99	9,525.0	5,980.1	870.9	6,034.5	0.00	0.00	0.00	
16,400.0	90.00	359.99	9,525.0	6,080.1	870.9	6,134.1	0.00	0.00	0.00	
16,500.0	90.00	359.99	9,525.0	6,180.1	870.9	6,233.6	0.00	0.00	0.00	
16,600.0	90.00	359.99	9,525.0	6,280.1	870.9	6,333.2	0.00	0.00	0.00	
16,700.0	90.00	359.99	9,525.0	6,380.1	870.8	6,432.8	0.00	0.00	0.00	
16,800.0	90.00	359.99	9,525.0	6,480.1	870.8	6,532.4	0.00	0.00	0.00	
16,900.0	90.00	359.99	9,525.0	6,580.1	870.8	6,632.0	0.00	0.00	0.00	
17,000.0	90.00	359.99	9,525.0	6,680.1	870.8	6,731.6	0.00	0.00	0.00	
17,100.0	90.00	359.99	9,525.0	6,780.1	870.8	6,831.1	0.00	0.00	0.00	
17,200.0	90.00	359.99	9,525.0	6,880.1	870.8	6,930.7	0.00	0.00	0.00	
17,300.0	90.00	359.99	9,525.0	6,980.1	870.7	7,030.3	0.00	0.00	0.00	
17,400.0	90.00	359.99	9,525.0	7,080.1	870.7	7,129.9	0.00	0.00	0.00	
17,500.0	90.00	359.99	9,525.0	7,180.1	870.7	7,229.5	0.00	0.00	0.00	
17,600.0	90.00	359.99	9,525.0	7,280.1	870.7	7,329.1	0.00	0.00	0.00	
17,700.0	90.00	359.99	9,525.0	7,380.1	870.7	7,428.7	0.00	0.00	0.00	
17,800.0	90.00	359.99	9,525.0	7,480.1	870.6	7,528.2	0.00	0.00	0.00	
17,900.0	90.00	359.99	9,525.0	7,580.1	870.6	7,627.8	0.00	0.00	0.00	
18,000.0	90.00	359.99	9,525.0	7,680.1	870.6	7,727.4	0.00	0.00	0.00	
18,100.0	90.00	359.99	9,525.0	7,780.1	870.6	7,827.0	0.00	0.00	0.00	
18,200.0	90.00	359.98	9,525.0	7,880.1	870.5	7,926.6	0.00	0.00	0.00	
18,300.0	90.00	359.98	9,525.0	7,980.1	870.5	8,026.2	0.00	0.00	0.00	
18,400.0	90.00	359.98	9,525.0	8,080.1	870.5	8,125.7	0.00	0.00	0.00	
18,500.0	90.00	359.98	9,525.0	8,180.1	870.5	8,225.3	0.00	0.00	0.00	

Planning Report

Database:	EDT_18	Local Co-ordinate Reference:	Well #703H
Company:	Midland	TVD Reference:	kb = 26' @ 2975.0usft
Project:	Eddy County, NM (NAD 83 NME)	MD Reference:	kb = 26' @ 2975.0usft
Site:	Lavash 2 State Com	North Reference:	Grid
Well:	#703H	Survey Calculation Method:	Minimum Curvature
Wellbore:	OH		
Design:	Plan #0.1 RT		

Planned Survey										
Measured Depth (usft)	Inclination (°)	Azimuth (°)	Vertical Depth (usft)	+N/-S (usft)	+E/-W (usft)	Vertical Section (usft)	Dogleg Rate (°/100usft)	Build Rate (°/100usft)	Turn Rate (°/100usft)	
18,600.0	90.00	359.98	9,525.0	8,280.1	870.4	8,324.9	0.00	0.00	0.00	
18,700.0	90.00	359.98	9,525.0	8,380.1	870.4	8,424.5	0.00	0.00	0.00	
18,800.0	90.00	359.98	9,525.0	8,480.1	870.4	8,524.1	0.00	0.00	0.00	
18,900.0	90.00	359.98	9,525.0	8,580.1	870.3	8,623.7	0.00	0.00	0.00	
19,000.0	90.00	359.98	9,525.0	8,680.1	870.3	8,723.3	0.00	0.00	0.00	
19,100.0	90.00	359.98	9,525.0	8,780.1	870.3	8,822.8	0.00	0.00	0.00	
19,200.0	90.00	359.98	9,525.0	8,880.1	870.2	8,922.4	0.00	0.00	0.00	
19,300.0	90.00	359.98	9,525.0	8,980.1	870.2	9,022.0	0.00	0.00	0.00	
19,400.0	90.00	359.98	9,525.0	9,080.1	870.2	9,121.6	0.00	0.00	0.00	
19,500.0	90.00	359.98	9,525.0	9,180.1	870.1	9,221.2	0.00	0.00	0.00	
19,600.0	90.00	359.98	9,525.0	9,280.1	870.1	9,320.8	0.00	0.00	0.00	
19,700.0	90.00	359.98	9,525.0	9,380.1	870.1	9,420.3	0.00	0.00	0.00	
19,800.0	90.00	359.98	9,525.0	9,480.1	870.0	9,519.9	0.00	0.00	0.00	
19,857.9	90.00	359.98	9,525.0	9,538.0	870.0	9,577.6	0.00	0.00	0.00	

Design Targets										
Target Name - hit/miss target - Shape	Dip Angle (°)	Dip Dir. (°)	TVD (usft)	+N/-S (usft)	+E/-W (usft)	Northing (usft)	Easting (usft)	Latitude	Longitude	
KOP(Lavash 2 State Co - plan hits target center - Point	0.00	0.00	9,047.5	-876.0	875.0	387,361.00	625,748.00	32° 3' 52.712 N	104° 3' 39.024 W	
FTP(Lavash 2 State Cor - plan hits target center - Point	0.00	0.00	9,482.3	-596.0	872.0	387,641.00	625,745.00	32° 3' 55.483 N	104° 3' 39.051 W	
PBHL(Lavash 2 State Cr - plan hits target center - Point	0.00	0.00	9,525.0	9,538.0	870.0	397,775.00	625,743.00	32° 5' 35.771 N	104° 3' 38.776 W	
Fed Perf 1(Lavash 2 Sta - plan hits target center - Point	0.00	0.00	9,525.0	4,334.0	871.0	392,571.00	625,744.00	32° 4' 44.271 N	104° 3' 38.918 W	



Lavash 2 State Com 703H API #: 30-015-*** Variances**

EOG respectfully requests the below variances to be applied to the above well:

- Variance is requested to waive the centralizer requirements for the intermediate casing in the intermediate hole. An expansion additive will be utilized, in the cement slurry, for the entire length of the intermediate interval to maximize cement bond and zonal isolation.
- Variance is also requested to waive the centralizer requirements for the production casing in the production hole. An expansion additive will be utilized, in the cement slurry, for the entire length of the production interval to maximize cement bond and zonal isolation.
- EOG requests a variance to set the intermediate casing shoe in the Bone Spring formation or the Wolfcamp formation, depending on depletion in the area and well conditions. EOG will monitor the well and ensure the well is static before casing operations begin.

- Variance is requested to use a co-flex line between the BOP and choke manifold (instead of using a 4" OD steel line).
- Variance is requested to use a 5,000 psi annular BOP with the 10,000 psi BOP stack.
- EOG Resources requests the option to contract a Surface Rig to drill, set surface casing, and Cement on the subject well. After WOC 8 hours or 500 psi compressive strength (whichever is greater), the Surface Rig will move off so the wellhead can be installed. A welder will cut the casing to the proper height and weld on the wellhead (both "A" and "B" sections). The weld will be tested to 1,500 psi. All valves will be closed and a wellhead cap will be installed (diagram attached). If the timing between rigs is such that EOG Resources would not be able to preset the surface, the Primary Rig will MIRU and drill the well in its entirety per the APD.

EOG requests the additional variance(s) in the attached document(s):

- EOG BLM Variance 2a - Intermediate Bradenhead Cement
- EOG BLM Variance 2b - Bonespring/Wolfcamp Intermediate Casing Setpoint
- EOG BLM Variance 3a_b - BOP Break-test and Offline Intermediate Cement
- EOG BLM Variance 3d - Production Offline Cement

Eddy County, NM (NAD 83 NME)

Lavash 2 State Com #703H

Plan #0.1 RT

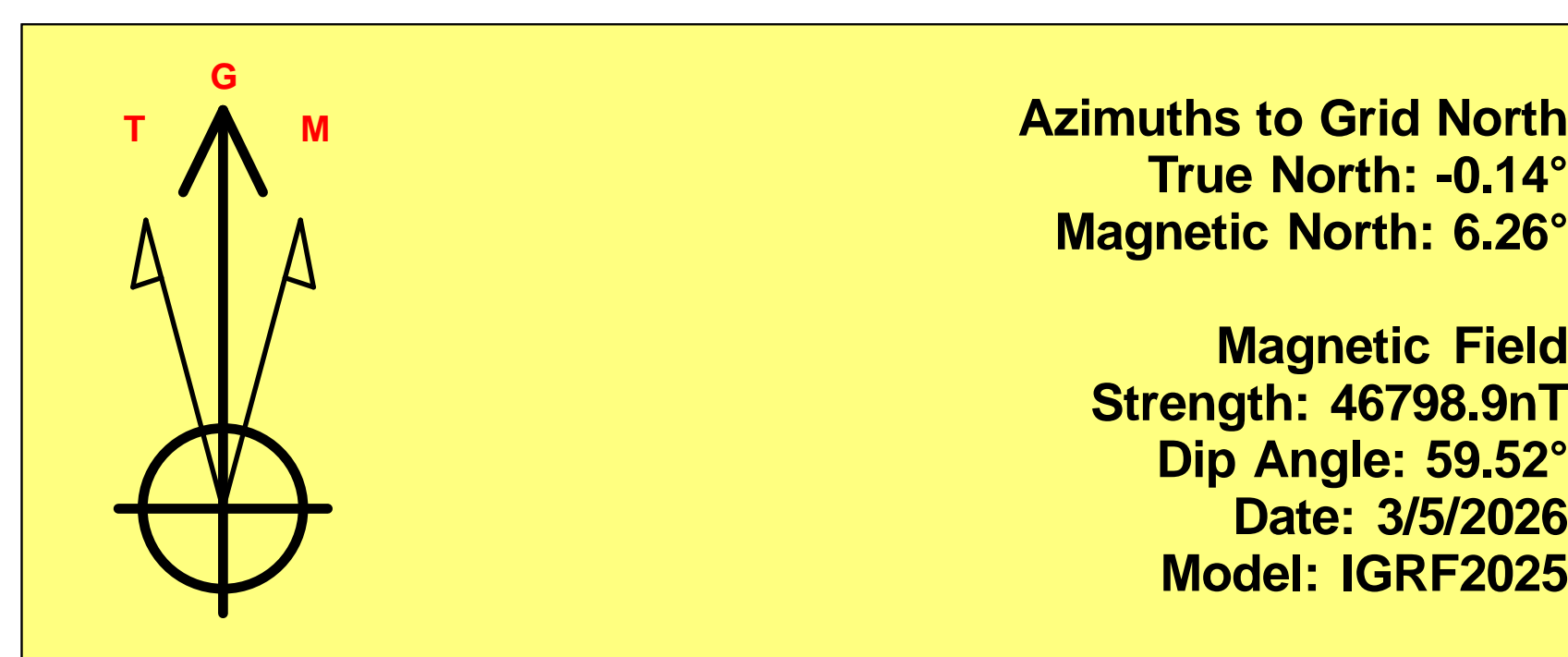

To convert a Magnetic Direction to a Grid Direction, Add 6.26°
 To convert a Magnetic Direction to a True Direction, Add 6.41° East
 To convert a True Direction to a Grid Direction, Subtract 0.14°

PROJECT DETAILS: Eddy County, NM (NAD 83 NME)

Geodetic System: US State Plane 1983
 Datum: North American Datum 1983
 Ellipsoid: GRS 1980
 Zone: New Mexico Eastern Zone
 System Datum: Mean Sea Level

WELL DETAILS: #703H

2949.0
 kb = 26' @ 2975.0usft
 Northing 388237.00 Easting 624873.00 Latitude 32° 4' 1.403 N Longitude 104° 3' 49.167 W

SECTION DETAILS

Sec	MD	Inc	Azi	TVD	+N/-S	+E/-W	Dleg	TFace	VFace	Target
1	0.0	0.00	0.00	0.0	0.0	0.0	0.00	0.00	0.0	
2	2483.0	0.00	0.00	2483.0	0.0	0.0	0.00	0.00	0.0	
3	3073.2	11.80	135.03	3069.0	-42.9	42.8	2.00	135.03	-38.8	
4	8533.6	11.80	135.03	8414.0	-833.1	832.2	2.00	180.00	-754.1	
5	9123.8	0.00	0.00	9000.0	-876.0	875.0	2.00	180.00	-792.9	
6	9171.3	0.00	0.00	9047.5	-876.0	875.0	0.00	0.00	-792.9	KOP(Lavash 2 State Com #703H)
7	9717.8	65.56	359.39	9482.3	-596.0	872.0	12.00	359.39	-514.3	FTP(Lavash 2 State Com #703H)
8	9921.5	90.00	0.00	9525.1	-398.4	871.0	12.00	1.48	-317.7	
9	14653.9	90.00	0.00	9525.0	4334.0	871.0	0.00	0.00	4395.2	Fed Perf 1(Lavash 2 State Com #703H)
10	19857.9	90.00	359.98	9525.0	9538.0	870.0	0.00	-95.14	9577.6	PBHL(Lavash 2 State Com #703H)

WELLBORE TARGET DETAILS (MAP CO-ORDINATES)

Name	TVD	+N/-S	+E/-W	Northing	Easting
KOP(Lavash 2 State Com #703H)	9047.5	-876.0	875.0	387361.00	625748.00
FTP(Lavash 2 State Com #703H)	9482.3	-596.0	872.0	387641.00	625745.00
Fed Perf 1(Lavash 2 State Com #703H)	9525.0	4334.0	871.0	392571.00	625744.00
PBHL(Lavash 2 State Com #703H)	9525.0	9538.0	870.0	397775.00	625743.00

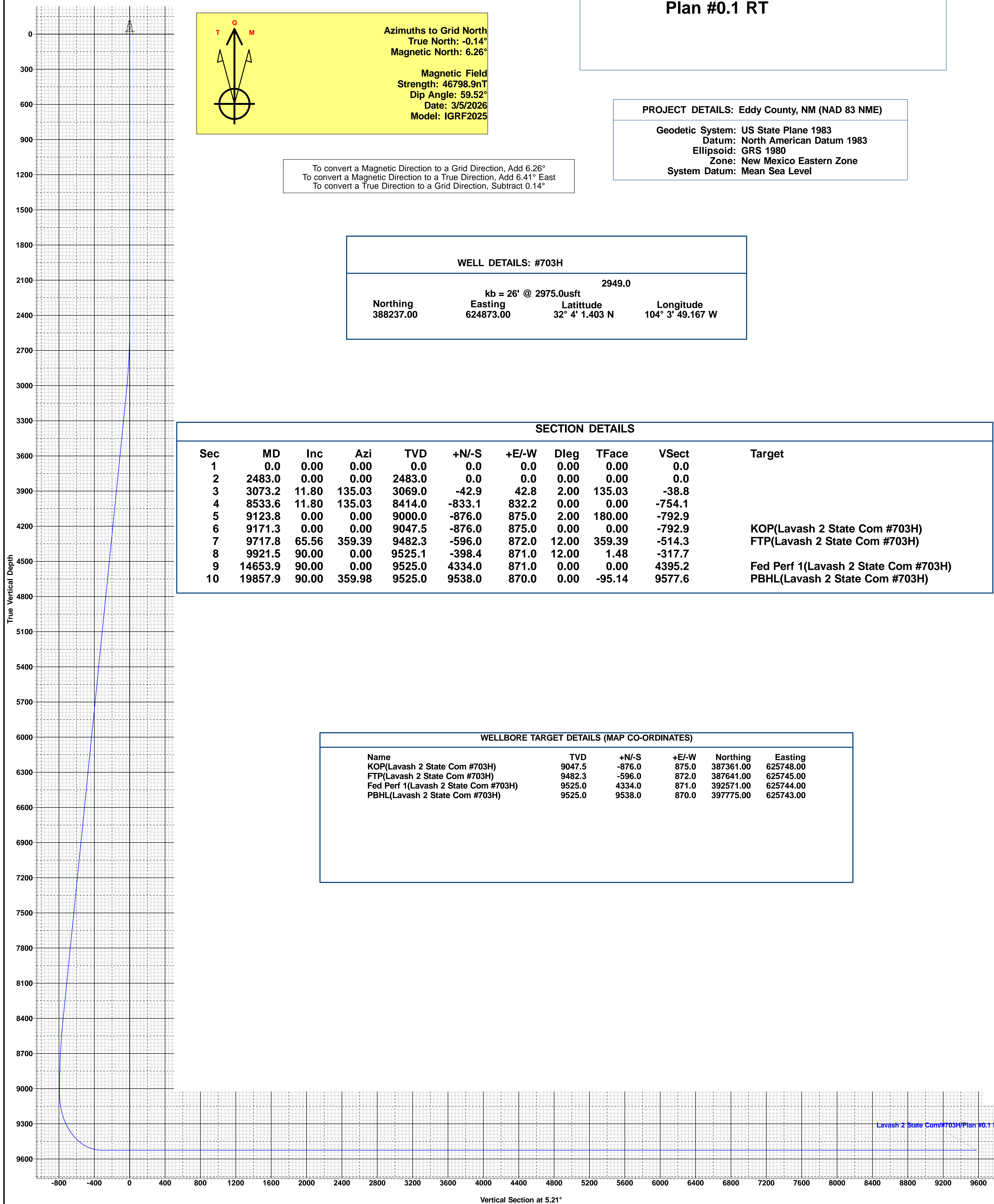
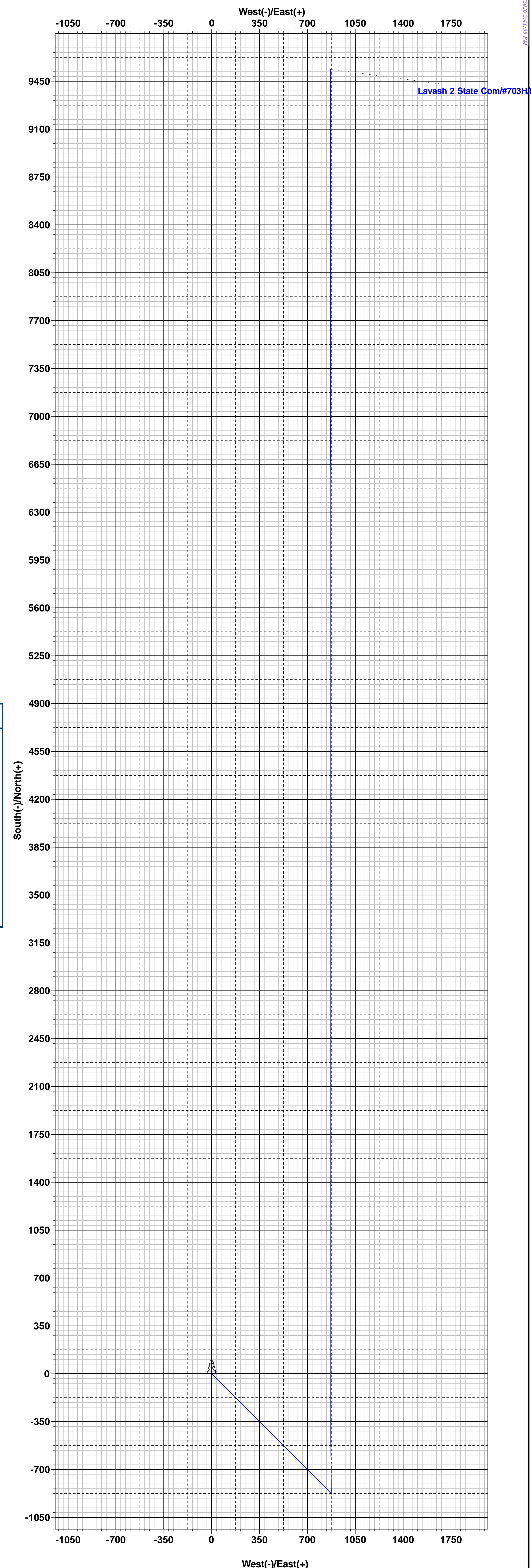

State of New Mexico
 Energy, Minerals and Natural Resources Department

Submit Electronically
 Via E-permitting

Oil Conservation Division
 1220 South St. Francis Dr.
 Santa Fe, NM 87505

NATURAL GAS MANAGEMENT PLAN

This Natural Gas Management Plan must be submitted with each Application for Permit to Drill (APD) for a new or recompleted well.

Section 1 – Plan Description Effective May 25, 2021

I. Operator: EOG Resources, Inc. **OGRID:** 7377 **Date:** 02/10/2026

II. Type: Original Amendment due to 19.15.27.9.D(6)(a) NMAC 19.15.27.9.D(6)(b) NMAC Other.

If Other, please describe: _____

III. Well(s): Provide the following information for each new or recompleted well or set of wells proposed to be drilled or proposed to be recompleted from a single well pad or connected to a central delivery point.

Well Name	API	ULSTR	Footages	Anticipated Oil BBL/D	Anticipated Gas MCF/D	Anticipated Produced Water BBL/D
Lavash 2 State Com 703H		O-2-26S-28E	940' FSL & 844' FWL	+/- 1000	+/- 3500	+/- 3000

IV. Central Delivery Point Name: Lavash 2 State Com CTB [See 19.15.27.9(D)(1) NMAC]

V. Anticipated Schedule: Provide the following information for each new or recompleted well or set of wells proposed to be drilled or proposed to be recompleted from a single well pad or connected to a central delivery point.

Well Name	API	Spud Date	TD Reached Date	Completion Commencement Date	Initial Flow Back Date	First Production Date
Lavash 2 State Com 703H		05/10/2026	06/15/26	07/01/26	08/01/26	09/01/26

VI. Separation Equipment: Attach a complete description of how Operator will size separation equipment to optimize gas capture.

VII. Operational Practices: Attach a complete description of the actions Operator will take to comply with the requirements of Subsection A through F of 19.15.27.8 NMAC.

VIII. Best Management Practices: Attach a complete description of Operator's best management practices to minimize venting during active and planned maintenance.

Section 2 – Enhanced Plan

EFFECTIVE APRIL 1, 2022

Beginning April 1, 2022, an operator that is not in compliance with its statewide natural gas capture requirement for the applicable reporting area must complete this section.

Operator certifies that it is not required to complete this section because Operator is in compliance with its statewide natural gas capture requirement for the applicable reporting area.

IX. Anticipated Natural Gas Production:

Well	API	Anticipated Average Natural Gas Rate MCF/D	Anticipated Volume of Natural Gas for the First Year MCF

X. Natural Gas Gathering System (NGGS):

Operator	System	ULSTR of Tie-in	Anticipated Gathering Start Date	Available Maximum Daily Capacity of System Segment Tie-in

XI. Map. Attach an accurate and legible map depicting the location of the well(s), the anticipated pipeline route(s) connecting the production operations to the existing or planned interconnect of the natural gas gathering system(s), and the maximum daily capacity of the segment or portion of the natural gas gathering system(s) to which the well(s) will be connected.

XII. Line Capacity. The natural gas gathering system will will not have capacity to gather 100% of the anticipated natural gas production volume from the well prior to the date of first production.

XIII. Line Pressure. Operator does does not anticipate that its existing well(s) connected to the same segment, or portion, of the natural gas gathering system(s) described above will continue to meet anticipated increases in line pressure caused by the new well(s).

Attach Operator’s plan to manage production in response to the increased line pressure.

XIV. Confidentiality: Operator asserts confidentiality pursuant to Section 71-2-8 NMSA 1978 for the information provided in Section 2 as provided in Paragraph (2) of Subsection D of 19.15.27.9 NMAC, and attaches a full description of the specific information for which confidentiality is asserted and the basis for such assertion.

Section 3 - Certifications

Effective May 25, 2021

Operator certifies that, after reasonable inquiry and based on the available information at the time of submittal:

Operator will be able to connect the well(s) to a natural gas gathering system in the general area with sufficient capacity to transport one hundred percent of the anticipated volume of natural gas produced from the well(s) commencing on the date of first production, taking into account the current and anticipated volumes of produced natural gas from other wells connected to the pipeline gathering system; or

Operator will not be able to connect to a natural gas gathering system in the general area with sufficient capacity to transport one hundred percent of the anticipated volume of natural gas produced from the well(s) commencing on the date of first production, taking into account the current and anticipated volumes of produced natural gas from other wells connected to the pipeline gathering system.

If Operator checks this box, Operator will select one of the following:

Well Shut-In. Operator will shut-in and not produce the well until it submits the certification required by Paragraph (4) of Subsection D of 19.15.27.9 NMAC; or

Venting and Flaring Plan. Operator has attached a venting and flaring plan that evaluates and selects one or more of the potential alternative beneficial uses for the natural gas until a natural gas gathering system is available, including:

- (a) power generation on lease;
- (b) power generation for grid;
- (c) compression on lease;
- (d) liquids removal on lease;
- (e) reinjection for underground storage;
- (f) reinjection for temporary storage;
- (g) reinjection for enhanced oil recovery;
- (h) fuel cell production; and
- (i) other alternative beneficial uses approved by the division.

Section 4 - Notices

1. If, at any time after Operator submits this Natural Gas Management Plan and before the well is spud:

(a) Operator becomes aware that the natural gas gathering system it planned to connect the well(s) to has become unavailable or will not have capacity to transport one hundred percent of the production from the well(s), no later than 20 days after becoming aware of such information, Operator shall submit for OCD's approval a new or revised venting and flaring plan containing the information specified in Paragraph (5) of Subsection D of 19.15.27.9 NMAC; or

(b) Operator becomes aware that it has, cumulatively for the year, become out of compliance with its baseline natural gas capture rate or natural gas capture requirement, no later than 20 days after becoming aware of such information, Operator shall submit for OCD's approval a new or revised Natural Gas Management Plan for each well it plans to spud during the next 90 days containing the information specified in Paragraph (2) of Subsection D of 19.15.27.9 NMAC, and shall file an update for each Natural Gas Management Plan until Operator is back in compliance with its baseline natural gas capture rate or natural gas capture requirement.

2. OCD may deny or conditionally approve an APD if Operator does not make a certification, fails to submit an adequate venting and flaring plan which includes alternative beneficial uses for the anticipated volume of natural gas produced, or if OCD determines that Operator will not have adequate natural gas takeaway capacity at the time a well will be spud.

I certify that, after reasonable inquiry, the statements in and attached to this Natural Gas Management Plan are true and correct to the best of my knowledge and acknowledge that a false statement may be subject to civil and criminal penalties under the Oil and Gas Act.

Signature:
Printed Name: KAYLA MCCONNELL
Title: Regulatory Specialist
E-mail Address: Kayla_mcconnell@eogresources.com
Date: 03/23/2026
Phone: (432) 265-6804
OIL CONSERVATION DIVISION (Only applicable when submitted as a standalone form)
Approved By:
Title:
Approval Date:
Conditions of Approval:

Natural Gas Management Plan**Items VI-VIII****VI. Separation Equipment: Attach a complete description of how Operator will size separation equipment to optimize gas capture.**

- Separation equipment will be sized to provide adequate separation for anticipated rates.
- Adequate separation relates to retention time for Liquid – Liquid separation and velocity for Gas-Liquid separation.
- Collection systems are appropriately sized to handle facility production rates on all (3) phases.
- Ancillary equipment and metering is selected to be serviced without flow interruptions or the need to release gas from the well.

VII. Operational Practices: Attach a complete description of the actions Operator will take to comply with the requirements of Subsection A through F 19.15.27.8 NMAC.**Drilling Operations**

- All flare stacks will be properly sized. The flare stacks will be located at a minimum 100' from the nearest surface hole location on the pad.
- All natural gas produced during drilling operations will be flared, unless there is an equipment malfunction and/or to avoid risk of an immediate and substantial adverse impact on safety and the environment, at which point the gas will be vented.

Completions/Recompletions Operations

- New wells will not be flowed back until they are connected to a properly sized gathering system.
- The facility will be built/sized for maximum anticipated flowrates and pressures to minimize waste.
- For flowback operations, multiple stages of separation will be used as well as excess VRU and blowers to make sure waste is minimized off the storage tanks and facility.
- During initial flowback, the well stream will be routed to separation equipment.
- At an existing facility, when necessary, post separation natural gas will be flared until it meets pipeline specifications, at which point it will be turned into a collection system.
- At a new facility, post separation natural gas will be vented until storage tanks can safely function, at which point it will be flared until it meets pipeline spec.

Production Operations

- Weekly AVOs will be performed on all facilities.
- All flares will be equipped with auto-ignition systems and continuous pilot operations.
- After a well is stabilized from liquid unloading, the well will be turned back into the collection system.
- All plunger lift systems will be optimized to limit the amount of waste.
- All tanks will have automatic gauging equipment installed.
- Leaking thief hatches found during AVOs will be cleaned and properly re-sealed.

Performance Standards

- Production equipment will be designed to handle maximum anticipated rates and pressure.
- All flared gas will be combusted in a flare stack that is properly sized and designed to ensure proper combustion.
- Weekly AVOs will be performed on all wells and facilities that produce more than 60 Mcfd.

Measurement & Estimation

- All volume that is flared and vented that is not measured will be estimated.
- All measurement equipment for flared volumes will conform to API 14.10.
- No meter bypasses will be installed.

- When metering is not practical due to low pressure/low rate, the vented or flared volume will be estimated.

VIII. Best Management Practices: Attach a complete description of Operator's best management practices to minimize venting during active and planned maintenance.

- During downhole well maintenance, EOG will use best management practices to vent as minimally as possible.
- Prior to the commencement of any maintenance, the tank or vessel will be isolated from the rest of the facilities.
- All valves upstream of the equipment will be closed and isolated.
- After equipment has been isolated, the equipment will be blown down to as low a pressure as possible into the collection system.
- If the equipment being maintained cannot be relieved into the collection system, it shall be released to a tank where the vapor can either be captured or combusted if possible.
- After downhole well maintenance, natural gas will be flared until it reaches pipeline specification.